

EPIC™ A32E

www.epicfit.com

Model No. EPEL12912.1

Serial No. _____

Write the serial number in the space above for reference.

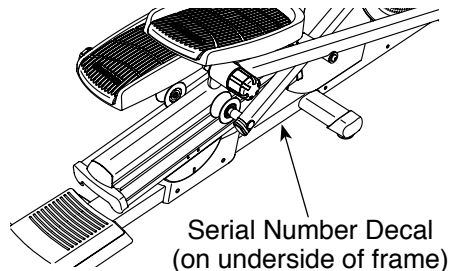

USER'S MANUAL

QUESTIONS?

If you have questions, or if parts are damaged or missing, **DO NOT CONTACT THE STORE**; please contact Customer Care.

IMPORTANT: Please register this product (see the limited warranty on the back cover of this manual) before contacting Customer Care.

VISIT OUR WEBSITE:

www.epicfit.com

Chat: Mon.–Fri. 6 a.m.–7 p.m. MT

CALL:

1-855-EPIC-FIT (1-855-374-2348)

Mon.–Fri. 6 a.m.–7 p.m. MT

EMAIL:

productsupport@epicfit.com

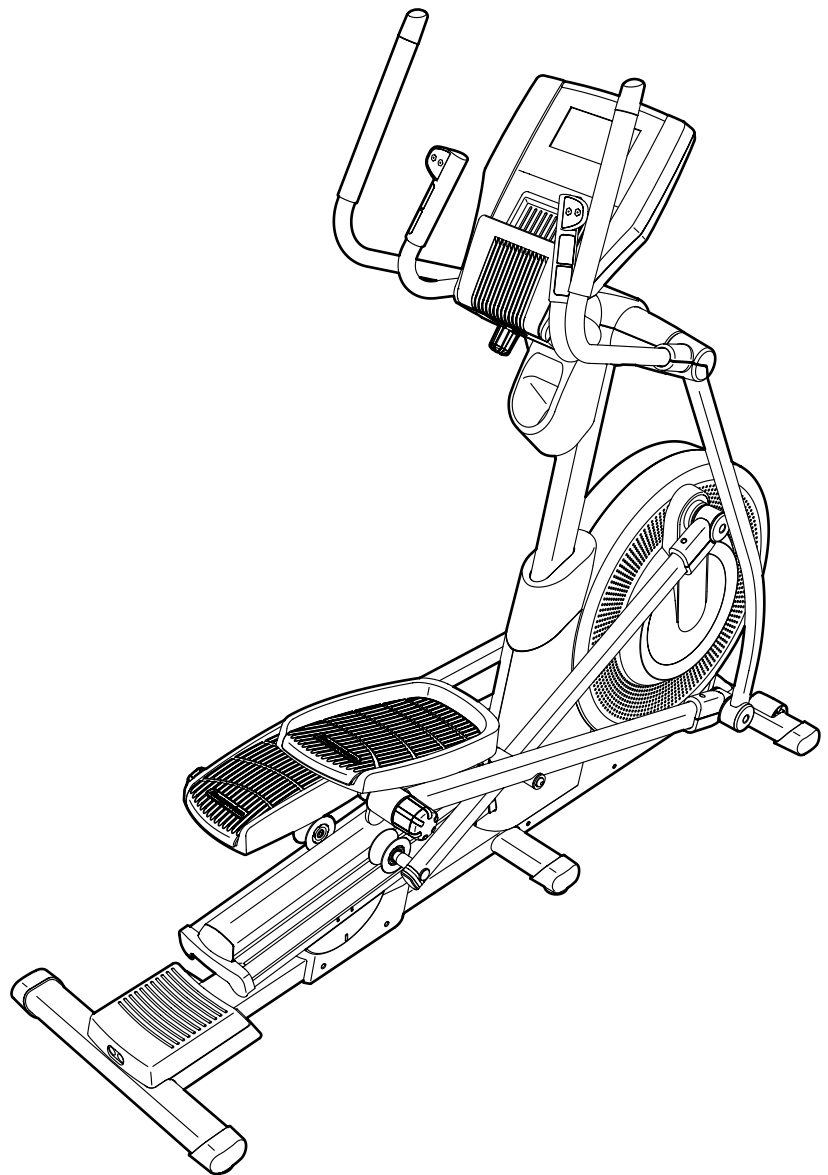

⚠ CAUTION

Read all precautions and instructions in this manual before using this equipment. Keep this manual for future reference.

FREE

iFIT®



HOW-TO
VIDEOS

www.iFit.com

TABLE OF CONTENTS

WARNING DECAL PLACEMENT	2
IMPORTANT PRECAUTIONS	3
BEFORE YOU BEGIN	4
PART IDENTIFICATION CHART	5
ASSEMBLY	6
THE CHEST HEART RATE MONITOR	16
HOW TO USE THE ELLIPTICAL	17
FCC INFORMATION	34
MAINTENANCE AND TROUBLESHOOTING	35
EXERCISE GUIDELINES	37
PART LIST	39
EXPLODED DRAWING	41
ORDERING REPLACEMENT PARTS	Back Cover
LIMITED WARRANTY	Back Cover

WARNING DECAL PLACEMENT

This drawing shows the location(s) of the warning decal(s). **If a decal is missing or illegible, see the front cover of this manual and request a free replacement decal. Apply the decal in the location shown.** Note: The decal(s) may not be shown at actual size.

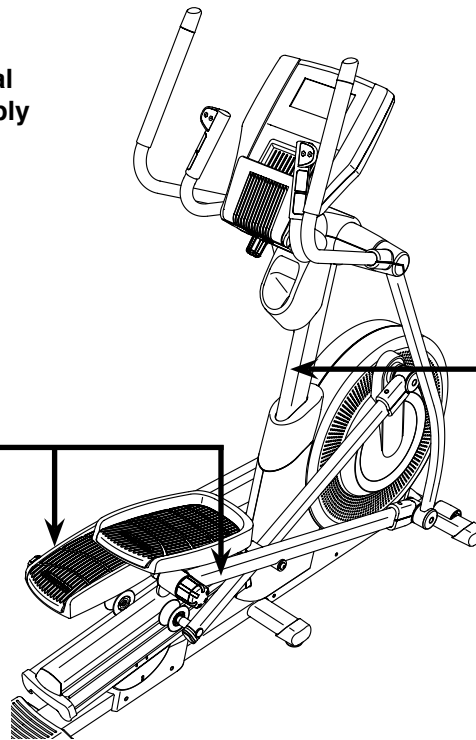

WARNING

- Misuse of this machine may result in serious injury.
- Read user's manual prior to use and follow all warnings and instructions.
- Do not allow children on or around machine.
- Pedals continue to spin when you stop pedaling.
- Spinning pedals can cause injury.
- Reduce pedal speed in a controlled manner.
- User weight must not exceed 375 lbs / 170 kgs.
- This product should always be used on a level surface.
- This product is not intended for therapeutic use.
- Replace label if damaged, illegible, or removed.



IMPORTANT PRECAUTIONS

⚠ WARNING: To reduce the risk of burns, fire, electric shock, or injury to persons, read all important precautions and instructions in this manual and all warnings on the elliptical before using the elliptical. ICON assumes no responsibility for personal injury or property damage sustained by or through the use of this product.

1. It is the responsibility of the owner to ensure that all users of the elliptical are adequately informed of all precautions.
2. Before beginning any exercise program, consult your physician. This is especially important for persons over age 35 or persons with pre-existing health problems.
3. Use the elliptical only as described in this manual.
4. The elliptical is intended for home use only. Do not use the elliptical in a commercial, rental, or institutional setting.
5. Keep the elliptical indoors, away from moisture and dust. Do not put the elliptical in a garage or covered patio or near water.
6. Place the elliptical on a level surface, with at least 3 ft. (0.9 m) of clearance in front of it, 4 ft. (1.2 m) behind it, and 2 ft. (0.6 m) on each side of it. To protect the floor or carpet from damage, place a mat under the elliptical.
7. Do not drop or insert any object into any opening on the elliptical.
8. Inspect and properly tighten all parts regularly. Replace any worn parts immediately.
9. Keep children under age 12 and pets away from the elliptical at all times.
10. The elliptical should not be used by persons weighing more than 375 lbs. (170 kg).
11. Wear appropriate clothes while exercising; do not wear loose clothes that could become caught on the elliptical. Always wear athletic shoes for foot protection while exercising.
12. Do not operate the elliptical if the power cord or plug is damaged or if the elliptical is not working properly. See the front cover of this manual if the elliptical is not working properly.
13. Plug the power cord into an appropriate outlet (see page 17). Keep the power cord away from heated surfaces.
14. Hold the handlebars or the upper body arms when mounting, dismounting, or using the elliptical.
15. The heart rate monitor is not a medical device. Various factors may affect the accuracy of heart rate readings. The heart rate monitor is intended only as an exercise aid in determining heart rate trends in general.
16. The elliptical does not have a freewheel; the pedals will continue to move until the flywheel stops. Reduce your pedaling speed in a controlled way.
17. Keep your back straight while using the elliptical; do not arch your back.
18. Over exercising may result in serious injury or death. If you feel faint or if you experience pain while exercising, stop immediately and cool down.
19. Never leave the elliptical unattended while the power cord is plugged in.
20. **DANGER:** Always press the power switch to the off position and unplug the power cord immediately after using the elliptical, before cleaning the elliptical, and before performing the maintenance and adjustment procedures described in this manual. Servicing other than the procedures described in this manual should be performed only by an authorized service representative.

SAVE THESE INSTRUCTIONS

BEFORE YOU BEGIN

Thank you for selecting the revolutionary EPIC™ A32E elliptical. The A32E elliptical provides an impressive selection of features designed to make your workouts at home more effective and enjoyable.

For your benefit, read this manual carefully before you use the elliptical. If you have questions after reading this manual, please see the front cover of this

manual. To help us assist you, note the product model number and serial number before contacting us. The model number and the location of the serial number decal are shown on the front cover of this manual.

Before reading further, please familiarize yourself with the parts that are labeled in the drawing below.

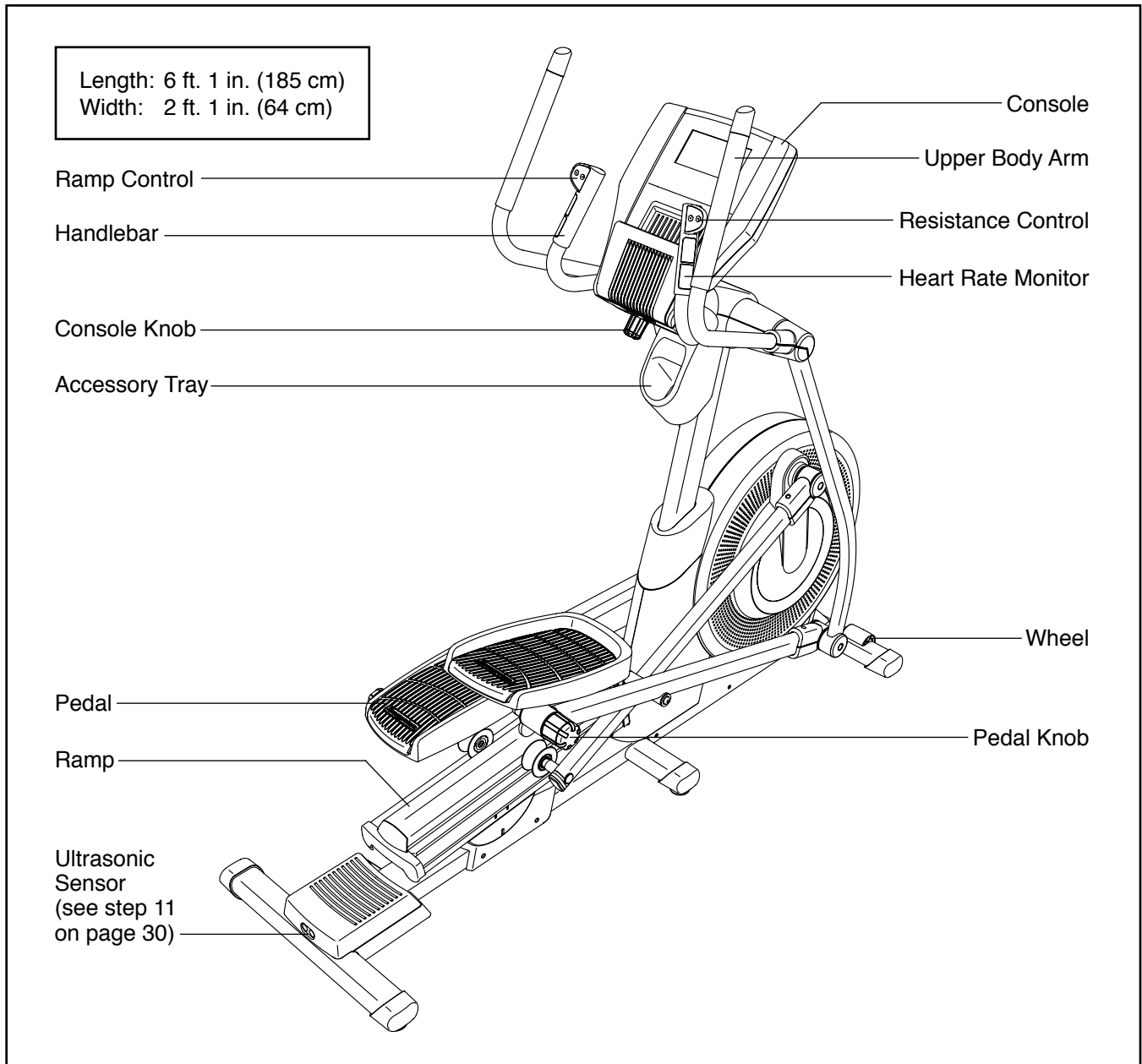

PART IDENTIFICATION CHART

Use the drawings below to identify the small parts needed for assembly. The number in parentheses below each drawing is the key number of the part, from the PART LIST near the end of this manual. The number following the key number is the quantity needed for assembly. **Note: If a part is not in the hardware kit, check to see if it has been preassembled. Extra parts may be included.**

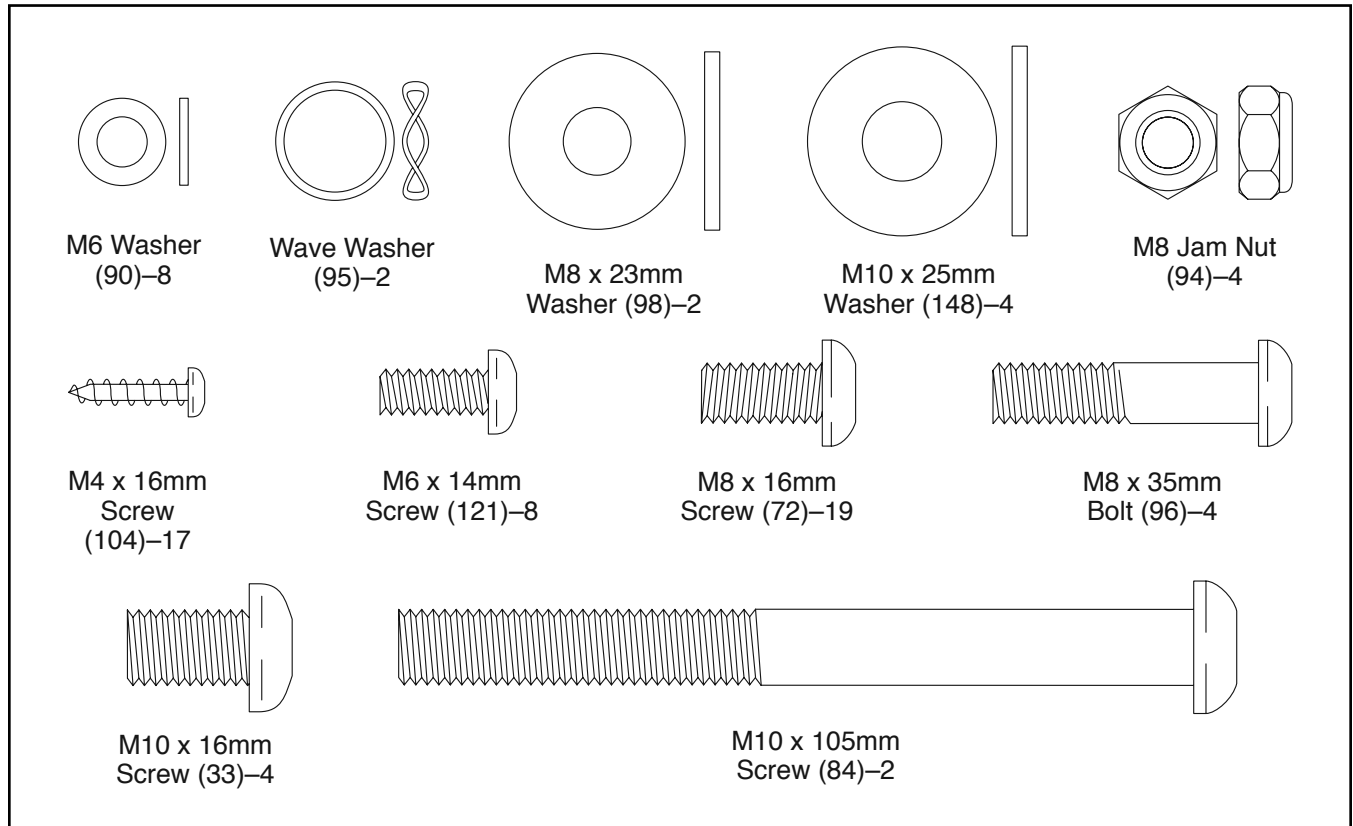

ASSEMBLY

- To watch an assembly video, go to <http://productvideo.co/assembly/dsg/epic> or use your mobile phone or smartphone to read the QR code with an application such as ShopSavvy.

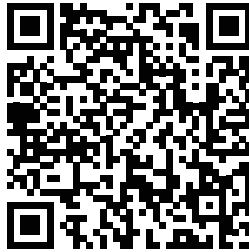

- Assembly requires two persons.
- Place all parts in a cleared area and remove the packing materials. Do not dispose of the packing materials until you finish all assembly steps.

- Left and right parts are marked “L” or “Left” and “R” or “Right.”

- To identify small parts, see page 5.

- In addition to the included tool(s), assembly requires the following tools:

one Phillips screwdriver



one rubber mallet



Assembly may be easier if you have a set of wrenches. To avoid damaging parts, do not use power tools.

1. Set a sturdy piece of packing material under the front of the Frame (1). **Have a second person hold the Frame to prevent it from tipping while you complete this step.**

Attach the Front Stabilizer (6) to the front of the Frame (1) with two M10 x 105mm Screws (84).

Remove the packing material.

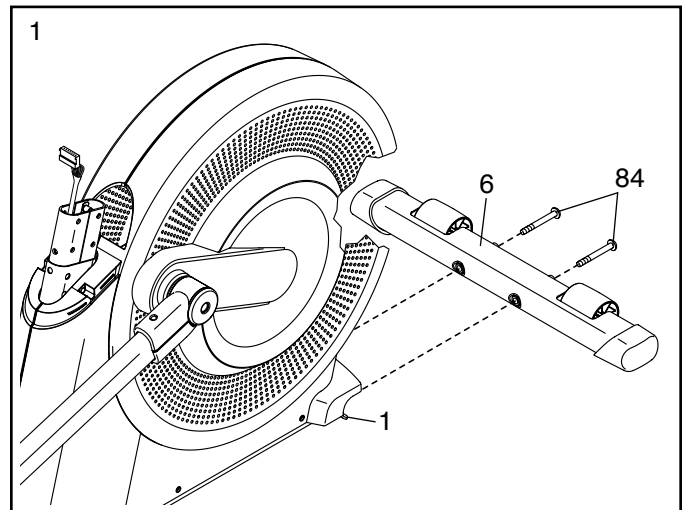

2. Set the Rear Stabilizer (5) on the floor behind the Frame (1). Locate the wire tie in the Rear Stabilizer.

See the inset drawing. Tie the end of the wire tie to the Sensor Wire Harness (155).

Pull the other end of the wire tie until the Sensor Wire Harness (155) is routed through the Rear Stabilizer (5).

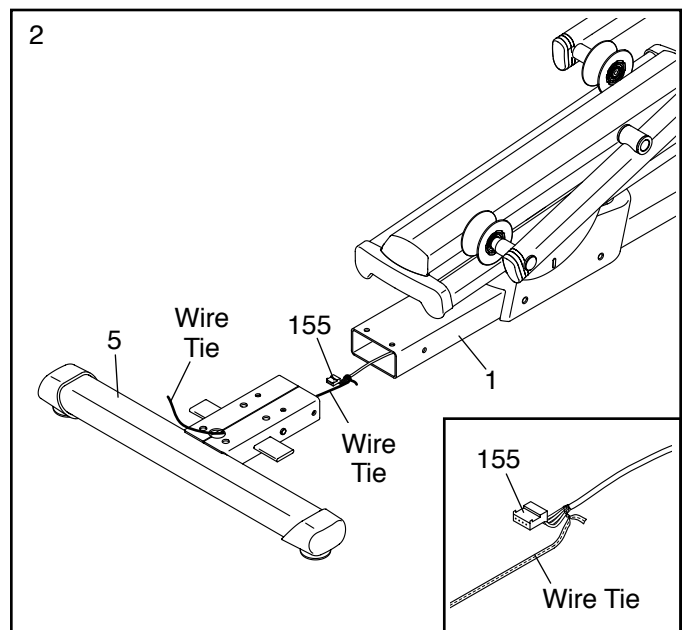

3. **Tip: Avoid pinching the Sensor Wire Harness (155).**

Set a sturdy piece of packing material under the rear of the Frame (1). **Have a second person hold the Frame to prevent it from tipping while you complete this step.**

Insert the Rear Stabilizer (5) into the Frame (1). Attach the Rear Stabilizer with four M8 x 16mm Screws (72); **start all four Screws, and then tighten them.**

Remove the packing material.

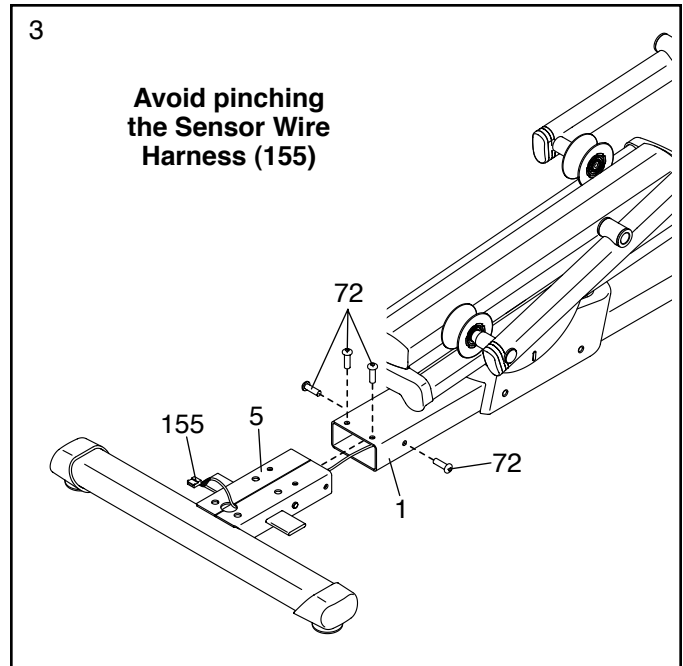

4. Untie and discard the wire tie (not shown) on the Sensor Wire Harness (155).

While a second person holds the Rear Stabilizer Cover (2) near the Rear Stabilizer (5), connect the wire on the Ultrasonic Sensor (147) to the Sensor Wire Harness (155). Insert the excess wire into the Rear Stabilizer.

Tip: Avoid pinching the Sensor Wire Harness (155). Press the four Mounts (117) on the underside of the Rear Stabilizer Cover (2) into the Rear Stabilizer (5).

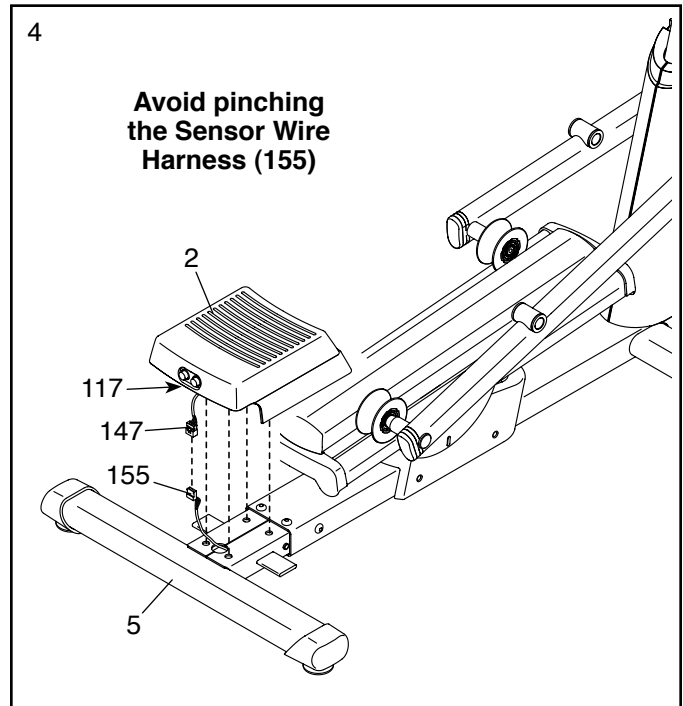

5. Identify the Lower Upright Cover (80), which has a large oval hole in it.

Orient the Lower Upright Cover (80), the Shield Cover (75), and the Upright (4) as shown. Slide the Lower Upright Cover and the Shield Cover upward onto the Upright.

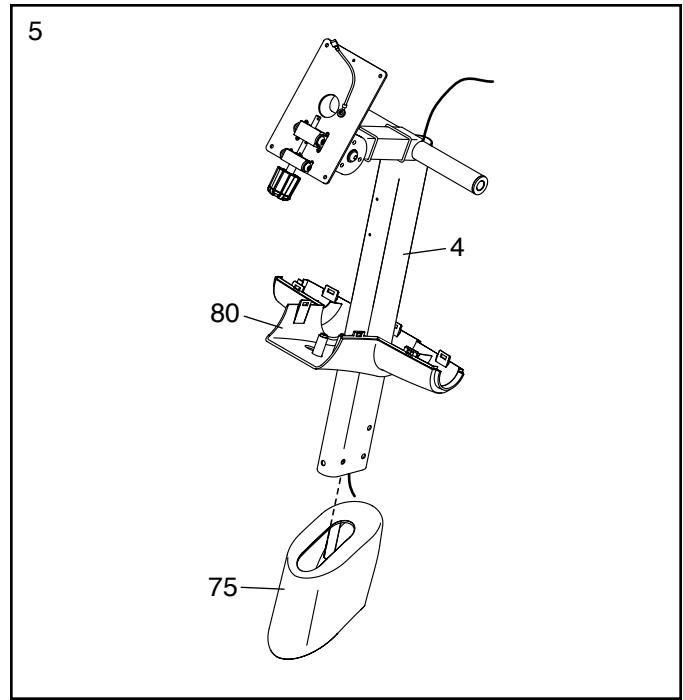

6. While a second person holds the Upright (4) near the Frame (1), locate the wire tie in the Upright.

See the inset drawing. Tie the lower end of the wire tie to the Main Wire Harness (110).

Pull the upper end of the wire tie until the Main Wire Harness (110) is routed through the Upright (4).

Tip: To prevent the Main Wire Harness (110) from falling into the Upright (4), secure the Main Wire Harness with the wire tie.

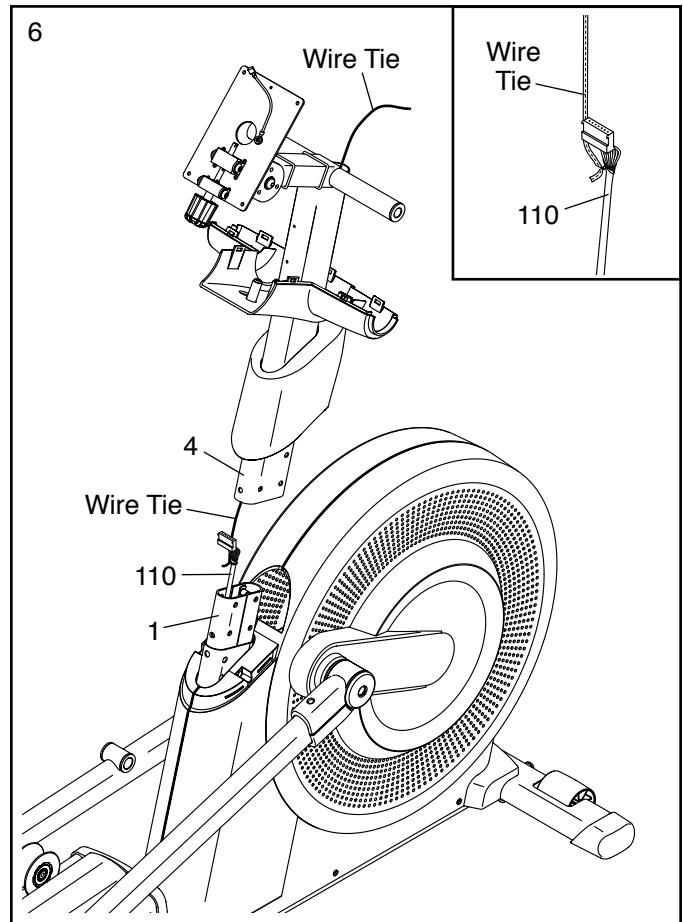

7. **Tip: Avoid pinching the Main Wire Harness (110).**

Slide the Upright (4) onto the Frame (1). Attach the Upright with seven M8 x 16mm Screws (72); do not fully tighten the Screws yet.

Do not press the Shield Cover (75) into place yet.

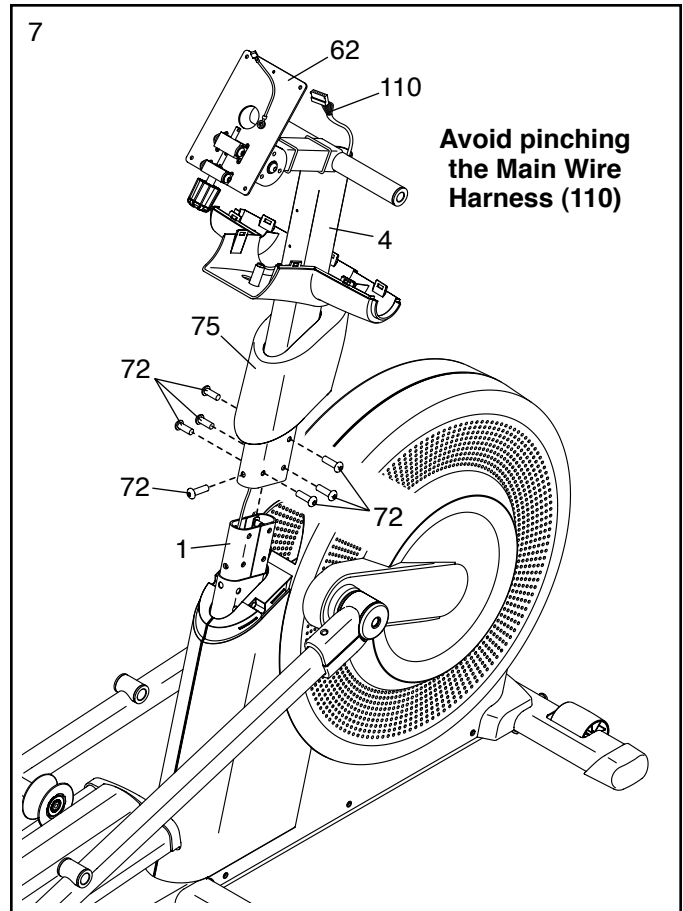

8. Identify the Right Pedal (49) and the Right Pedal Arm (58) and orient them as shown.

Attach the Right Pedal (49) to the Right Pedal Plate (139) on the Right Pedal Arm (58) with four M6 x 14mm Screws (121) and four M6 Washers (90).

Attach the Left Pedal (14) to the Left Pedal Arm (44) in the same way.

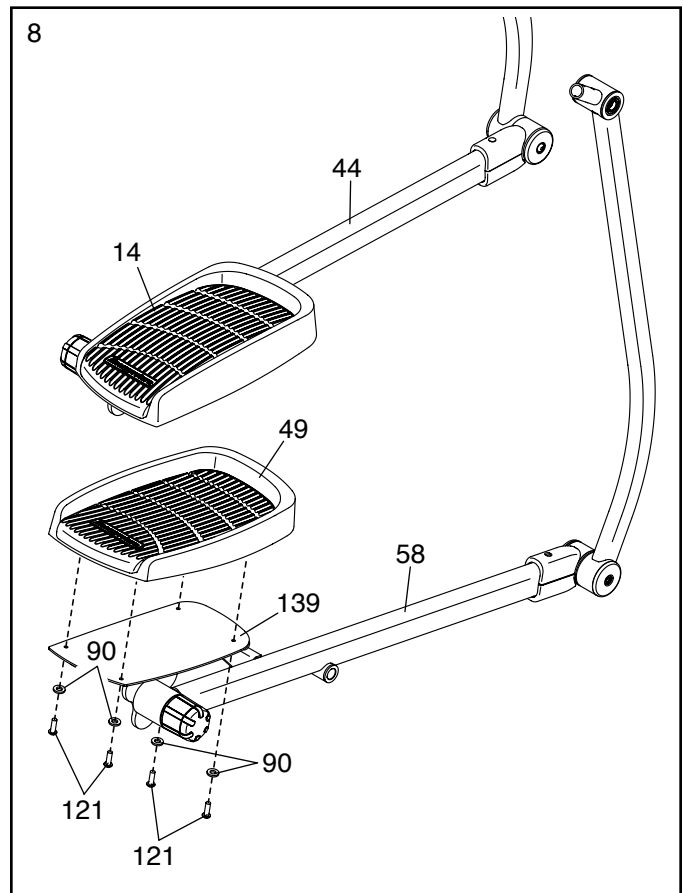

9. Using a plastic bag to keep your fingers clean, apply a generous amount of the included grease to the Arm Axle (35) and to two Wave Washers (95).

Insert the Arm Axle (35) into the Upright (4) and center it. Then, slide a Wave Washer (95) onto each end of the Arm Axle.

With the help of a second person, slide the Right Upper Body Leg (36) onto the right side of the Arm Axle (35). Move the Right Pedal Arm (58) to the right, and set it on the floor; **do not set it on the Ramp Top Cover (10)**.

With the help of a second person, slide the Left Upper Body Leg (46) onto the left side of the Arm Axle (35), and set the Left Pedal Arm (44) on the floor; **do not set it on the Ramp Top Cover (10)**.

Then, tighten an M8 x 16mm Screw (72) with an M8 x 23mm Washer (98) into each end of the Arm Axle (35) **at the same time**.

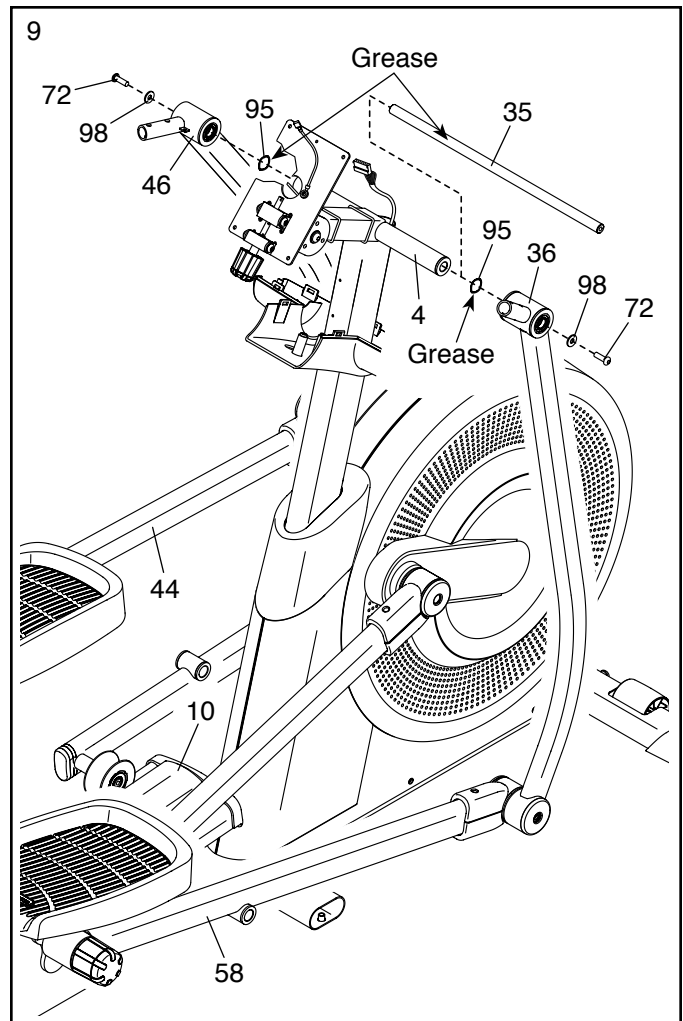

10. Apply a small amount of grease to a Pedal Arm Axle (24).

Insert the Pedal Arm Axle (24) into the Right Pedal Arm (58) and the Right Roller Arm (45).

Next, tighten an M10 x 16mm Screw (33) with an M10 x 25mm Washer (148) into each end of the Pedal Arm Axle (24) **at the same time**.

Then, tighten the indicated M8 x 16mm Screw (72).

Repeat this step on the left side of the elliptical.

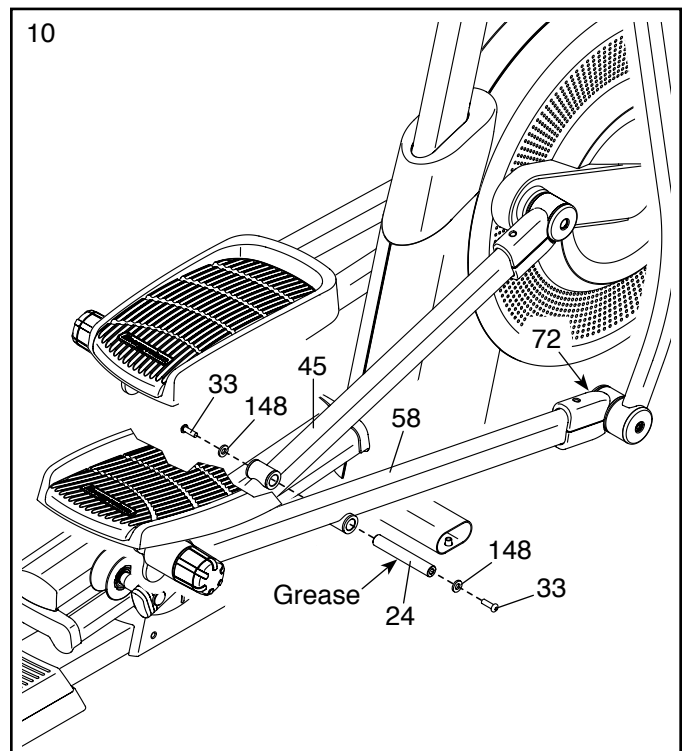

11. Tip: Avoid pinching the wires in the Right and Left Handlebars (83, 87).

Attach the Right Handlebar (83) to the right side of the Console Bracket (62) with three M8 x 16mm Screws (72).

Repeat this step with the Left Handlebar (87).

Then, remove the packaging from the wires on the Right and Left Handlebars (83, 87).

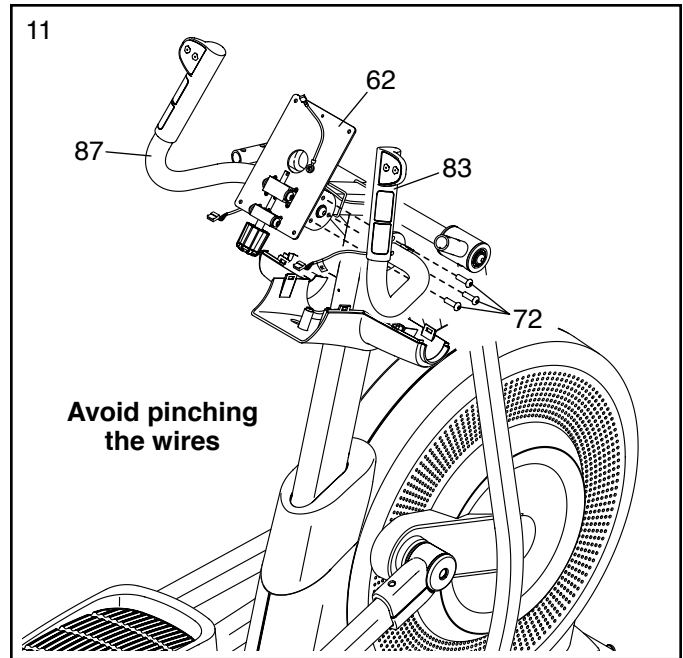

12. Slide the Right Upper Body Arm (61) onto the Right Upper Body Leg (36).

Attach the Right Upper Body Arm (61) with two M8 x 35mm Bolts (96) and two M8 Jam Nuts (94). **Make sure that the Jam Nuts are in the hexagonal holes in the Right Upper Body Arm.**

Attach the Left Upper Body Arm (47) in the same way.

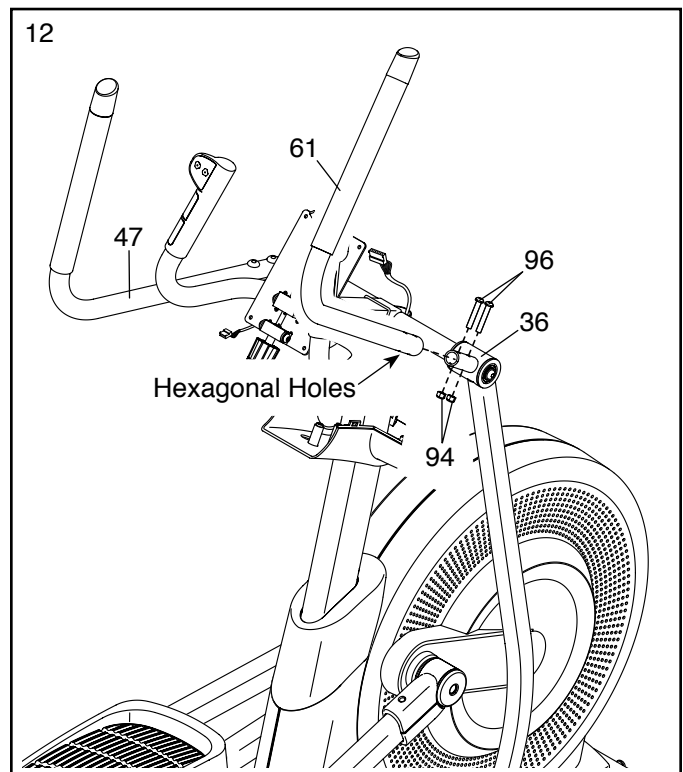

13. Have a second person hold the Console (7) near the Console Bracket (62).

Connect the Ground Wire (119) to the matching wire on the Console (7). Then, insert all of the wires on the Console **downward** through the indicated hole in the Console Bracket (62).

Tip: Avoid pinching the wires. Attach the Console (7) to the Console Bracket (62) with four M4 x 16mm Screws (104).

Untie and discard the wire tie (not shown) on the Main Wire Harness (110).

See the inset drawing. Connect the Main Wire Harness (110), the Receiver Wire Harness (146), and the two indicated wires to the matching wires on the Console (7). **Make sure to connect the wire that has a tag to the wire on the Console that has a tag.**

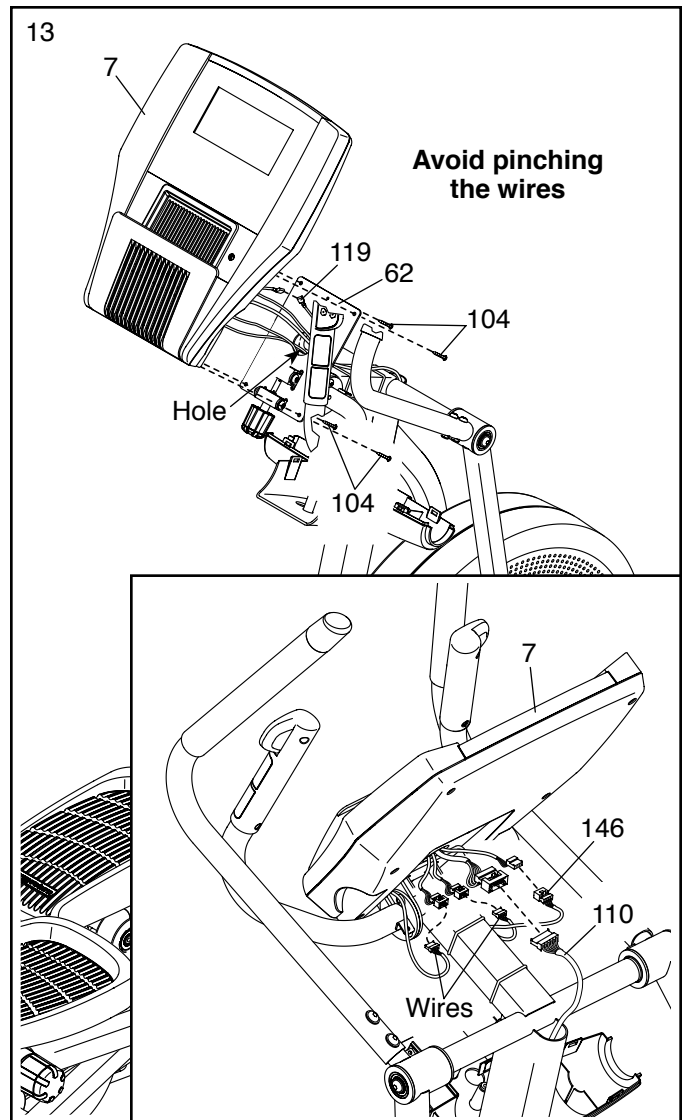

14. **Note:** For clarity, the Console and the wiring are not shown in this step.

Tip: It may be necessary to turn the Console Knob (52) and adjust the angle of the Console Bracket (62).

Attach the Upper Handlebar Cover (56) to the Right and Left Handlebars (83, 87) and to the Console Bracket (62) with three M4 x 16mm Screws (104); **start all three Screws, and then tighten them.**

Make sure that the wiring (not shown) is inside the Upper Handlebar Cover (56).

Then, press the Lower Handlebar Cover (60) onto the Upper Handlebar Cover (56).

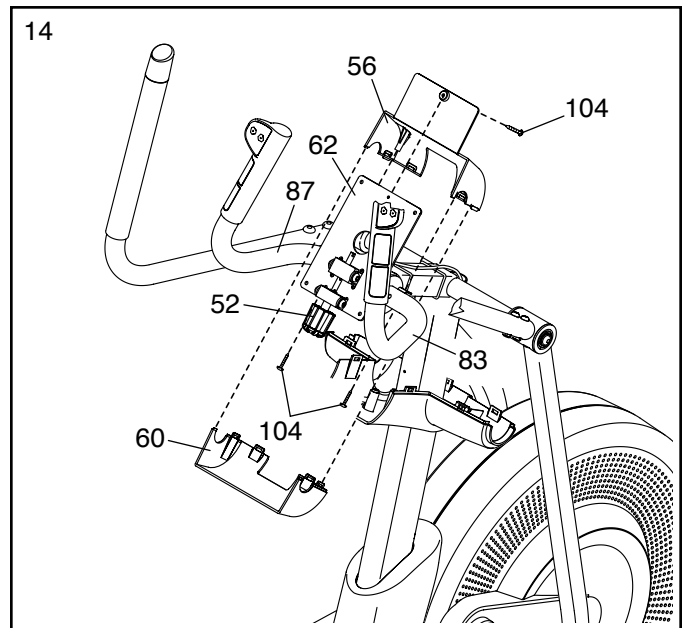

15. Slide the Lower Upright Cover (80) upward, and attach it to the Upright (4) with two M4 x 16mm Screws (104).

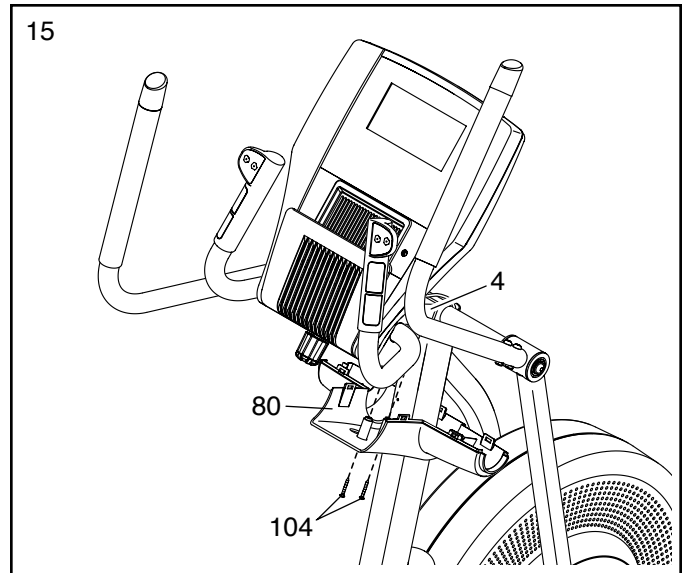

16. Attach the Accessory Tray Base (8) to the Upright (4) with two M4 x 16mm Screws (104).

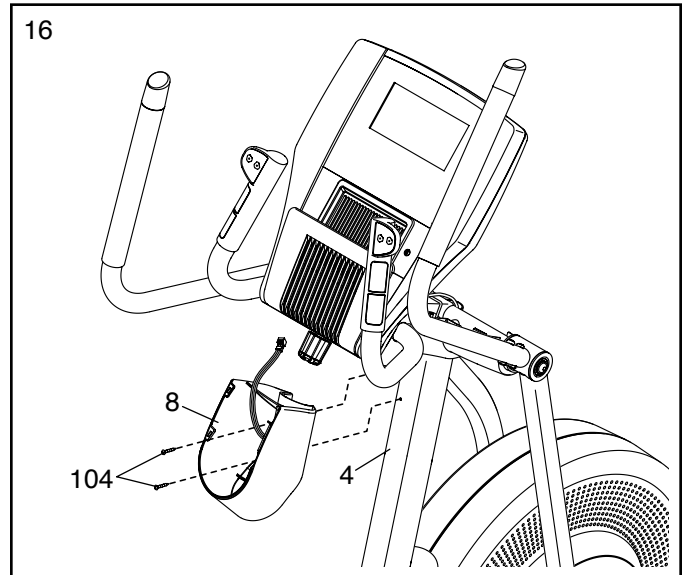

17. **See the left drawing.** Locate the receiver in the Accessory Tray Base (8). Insert the wire on the receiver into the indicated hole in the Lower Upright Cover (80).

See the right drawing. Locate the Receiver Wire Harness (146), which is attached to the Upright (4) with wire ties. Connect the Receiver Wire Harness to the wire on the receiver.

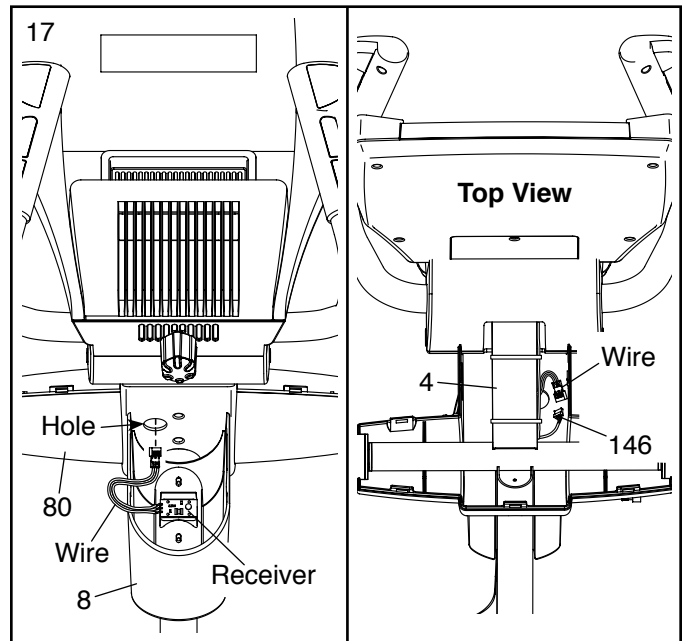

18. Press the Accessory Tray (37) into the Accessory Tray Base (8).

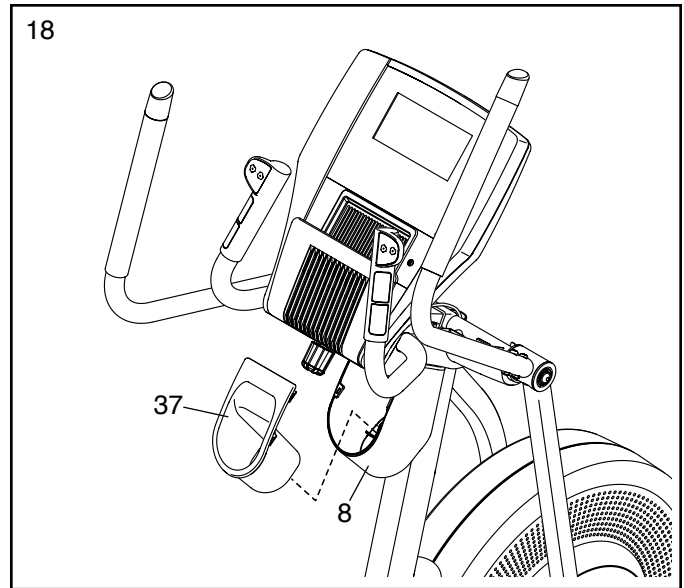

19. Press the Upper Upright Cover (91) onto the Lower Upright Cover (80).

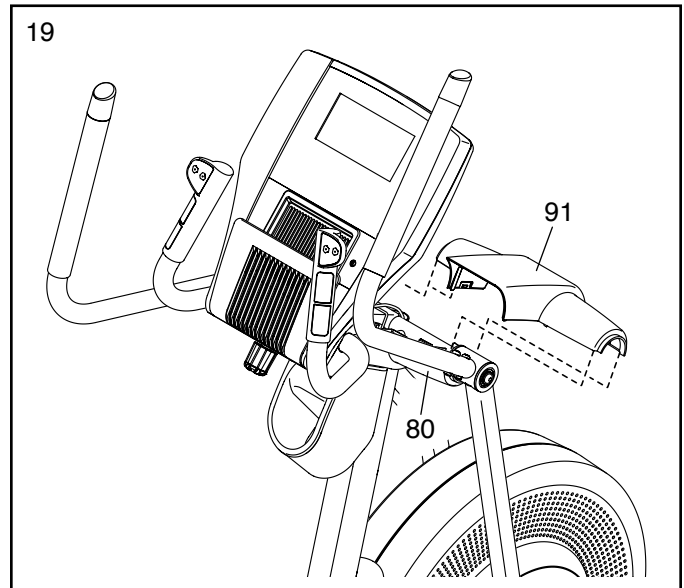

20. Identify the Right Arm Upper Cover (67) and the Right Arm Lower Cover (68).

Attach the Right Arm Upper Cover (67) to the Right Upper Body Leg (36) with an M4 x 16mm Screw (104).

Then, press the Right Arm Lower Cover (68) onto the Right Arm Upper Cover (67).

Attach the Left Arm Upper Cover (not shown) and the Left Arm Lower Cover (not shown) in the same way.

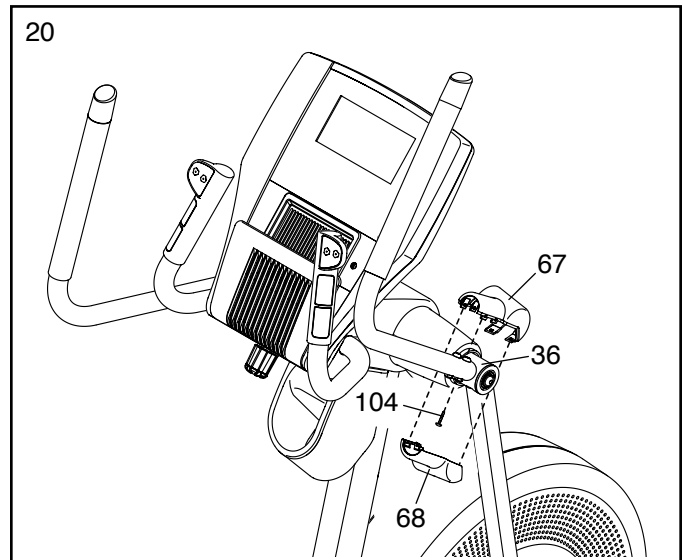

21. **See step 7.** Tighten the M8 x 16mm Screws (72).

Then, press the Shield Cover (75) downward onto the Left and Right Front Shields (73, 74).

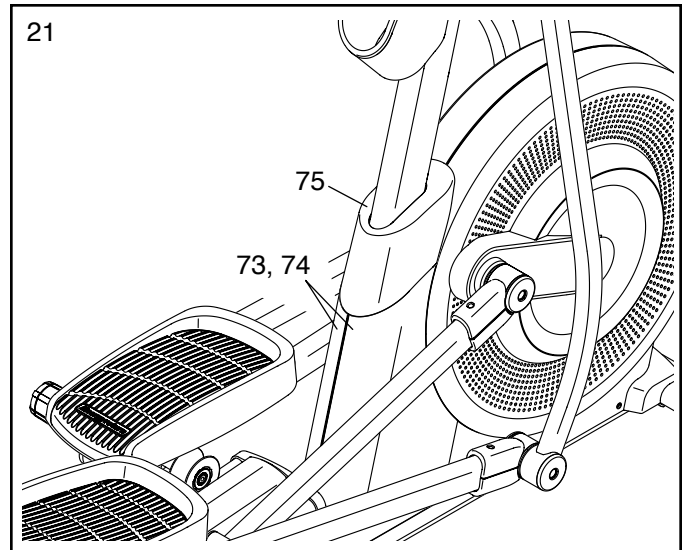

22. While a second person tips the elliptical to the left and holds it, attach a Stabilizer Cap (134) to the right side of the Frame (1) with two M4 x 16mm Screws (104).

Next, tighten a Leveling Foot (92) into the Frame (1) in the indicated location.

Repeat this step on the left side of the elliptical.

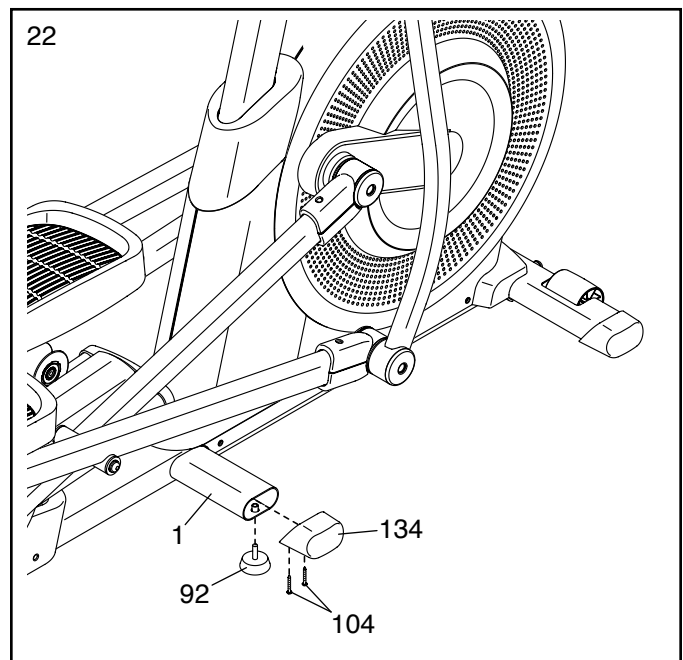

23. **Make sure that all parts are properly tightened before you use the elliptical.** Note: Extra parts may be included. Place a mat beneath the elliptical to protect the floor.

THE CHEST HEART RATE MONITOR

HOW TO PUT ON THE HEART RATE MONITOR

The heart rate monitor consists of a chest strap and a sensor. Insert the tab on one end of the chest strap into the hole in one end of the sensor as shown. Then, press the end of the sensor under the buckle on the chest strap. The tab should be flush with the front of the sensor.

The heart rate monitor must be worn under your clothes, tight against your skin. Wrap the heart rate monitor around your chest in the location shown. Make sure that the logo is right-side-up. Then, attach the other end of the chest strap to the sensor. Adjust the length of the chest strap, if necessary.

Pull the sensor away from your body a few inches and locate the two electrode areas, which are covered by shallow ridges. Using saline solution such as saliva or contact lens solution, wet the electrode areas. Then, return the sensor to a position against your chest.

CARE AND MAINTENANCE

- Thoroughly dry the sensor with a soft towel after each use. Moisture may keep the sensor activated, shortening the life of the battery.
- Store the heart rate monitor in a warm, dry place. Do not store the heart rate monitor in a plastic bag or other container that may trap moisture.

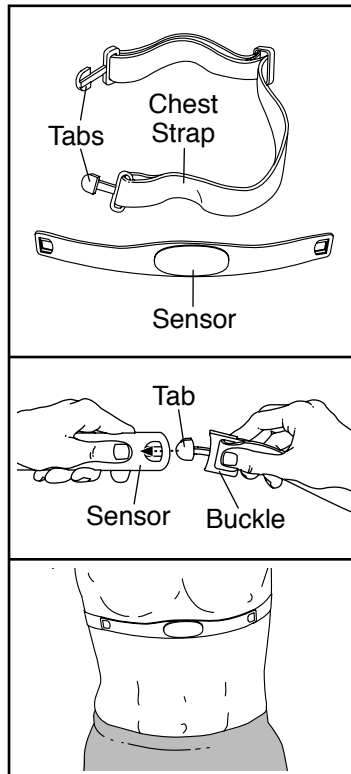

- Do not expose the heart rate monitor to direct sunlight for extended periods of time; do not expose it to temperatures above 122° F (50° C) or below 14° F (-10° C).
- Do not excessively bend or stretch the sensor when using or storing the heart rate monitor.
- To clean the sensor, use a damp cloth and a small amount of mild soap. Then, wipe the sensor with a damp cloth and thoroughly dry it with a soft towel. Never use alcohol, abrasives, or chemicals to clean the sensor. Hand wash and air dry the chest strap.

TROUBLESHOOTING

If the heart rate monitor does not function properly, try the steps below.

- Make sure that you are wearing the heart rate monitor as described at the left. If the heart rate monitor does not function when positioned as described, move it slightly lower or higher on your chest.
- If heart rate readings are not displayed until you begin perspiring, rewet the electrode areas.
- For the console to display heart rate readings, you must be within arm's length of the console.
- If there is a battery cover on the back of the sensor, replace the battery with a new battery of the same type.
- The heart rate monitor is designed to work with people who have normal heart rhythms. Heart rate reading problems may be caused by medical conditions such as premature ventricular contractions (pvc's), tachycardia bursts, and arrhythmia.
- The operation of the heart rate monitor can be affected by magnetic interference from high power lines or other sources. If you suspect that magnetic interference is causing a problem, try relocating the fitness equipment.

HOW TO USE THE ELLIPTICAL

HOW TO PLUG IN THE POWER CORD

This product must be grounded. If it should malfunction or break down, grounding provides a path of least resistance for electric current to reduce the risk of electric shock. The power cord has a plug with a grounding pin.

⚠ DANGER: Improper connection of the power cord increases the risk of electric shock. Do not modify the plug; if it will not fit an outlet, have a proper outlet installed by a qualified electrician. If you are unsure whether the product is properly grounded, contact a qualified electrician.

Plug the power cord into an appropriate outlet that is properly installed and grounded in accordance with all local codes and ordinances. The outlet must be on a nominal 120-volt circuit.

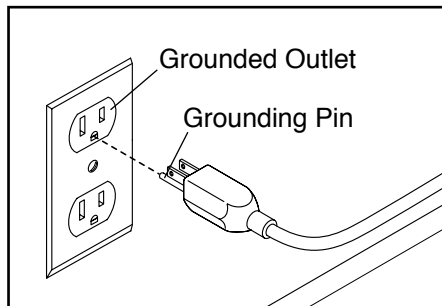

A temporary adapter may be used to connect the power cord to a 2-pole receptacle as shown at the right if a properly grounded outlet is not available.

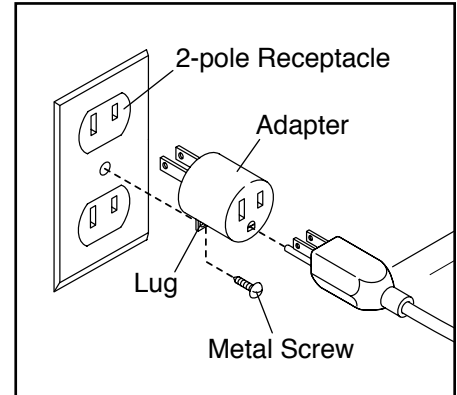

The lug or wire extending from the adapter must be connected with a metal screw to a permanent ground such as a properly grounded outlet box cover. **Some 2-pole receptacle outlet box covers are not grounded. Before using an adapter, contact a qualified electrician to determine whether the outlet box cover is grounded before using an adapter. The temporary adapter should be used only until a properly grounded outlet can be installed by a qualified electrician.**

HOW TO MOVE THE ELLIPTICAL

Due to the size and weight of the elliptical, moving it requires two persons. Stand in front of the elliptical, hold the upright, and place one foot against one of the wheels. Pull on the upright and have a second person lift the rear stabilizer until the elliptical will roll on the wheels. Carefully move the elliptical to the desired location, and then lower it to the floor.

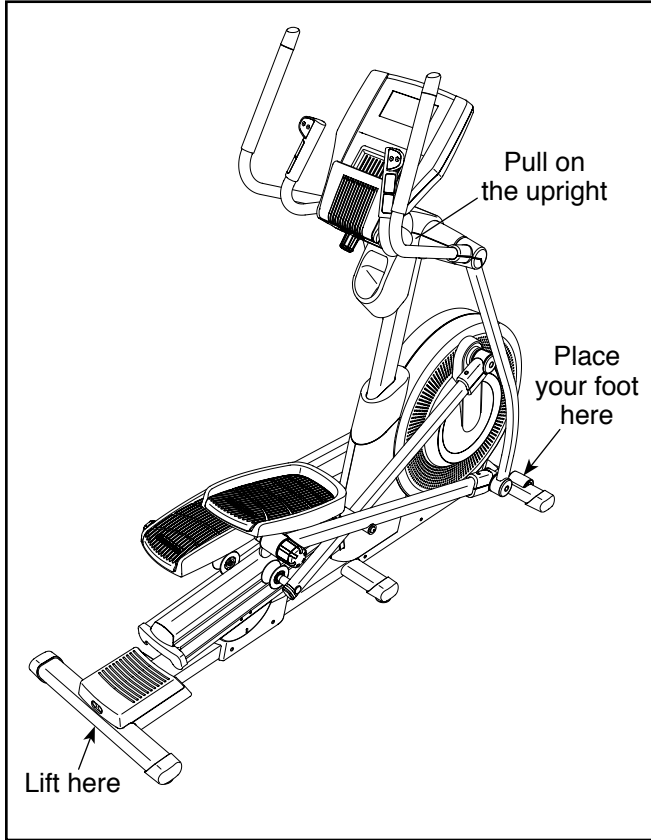

HOW TO ADJUST THE POSITIONS OF THE PEDALS

Each pedal can be adjusted to several positions. To adjust each pedal, lift the pedal and turn the pedal knob beneath the pedal. **Make sure to adjust both pedals to the same position.**

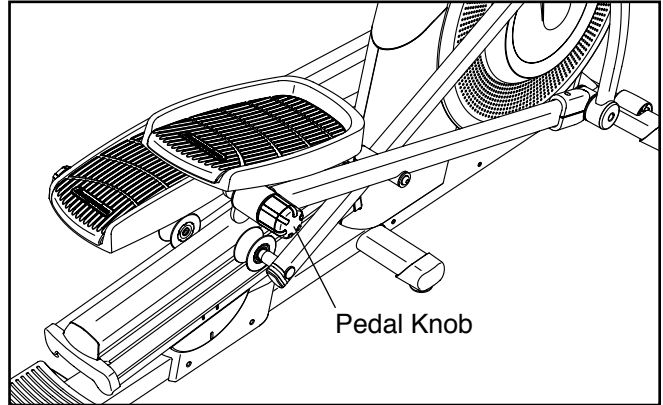

HOW TO ADJUST THE CONSOLE

The console can be adjusted to several angles. To adjust the console, turn the console knob until the console is at the desired angle.

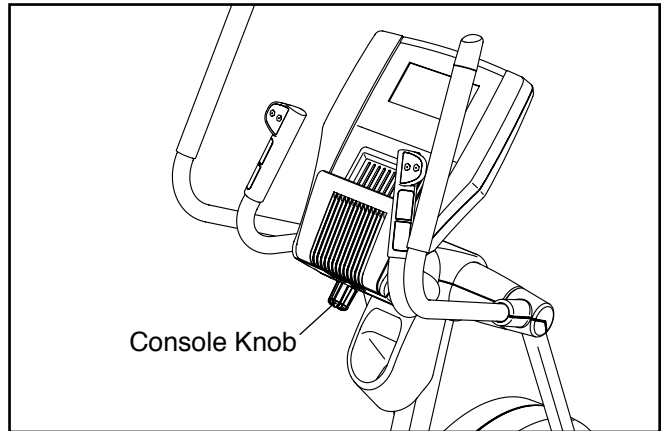

HOW TO LEVEL THE ELLIPTICAL

If the elliptical rocks slightly on your floor during use, turn one or both of the leveling feet beneath the rear stabilizer until the rocking motion is eliminated. Then, turn the leveling feet beneath the center stabilizer until the leveling feet touch your floor.

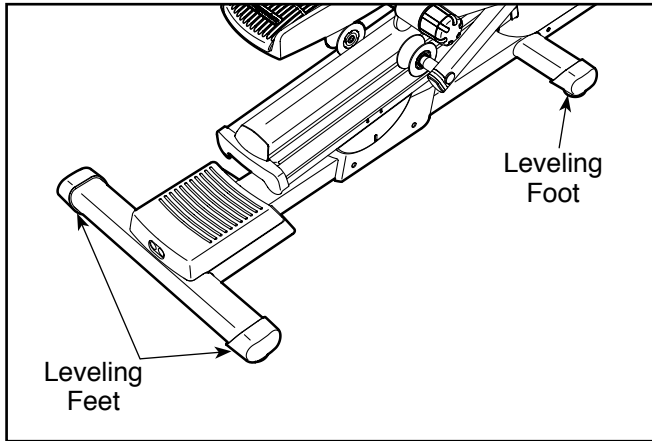

HOW TO EXERCISE ON THE ELLIPTICAL

To mount the elliptical, hold the upper body arms or the handlebars and step onto the pedal that is in the lower position. Then, step onto the other pedal. Push the pedals until they begin to move with a continuous motion. **Note: The crank arms can turn in either direction. It is recommended that you turn the crank arms in the direction shown by the arrow; however, for variety, you can turn the crank arms in the opposite direction.**

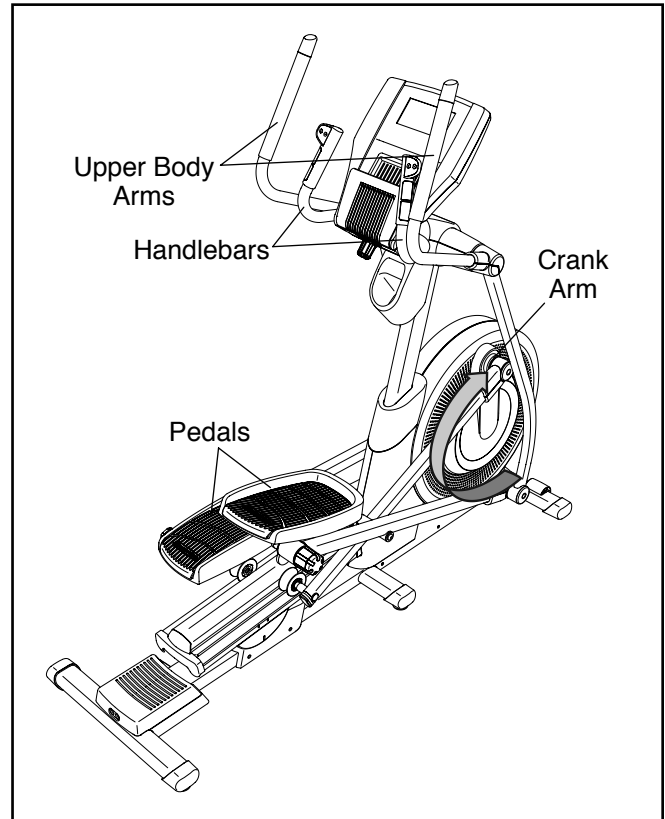

To dismount the elliptical, wait until the pedals come to a complete stop. **Note: The elliptical does not have a free wheel; the pedals will continue to move until the flywheel stops.** When the pedals are stationary, step off the higher pedal first. Then, step off the lower pedal.

CONSOLE DIAGRAM

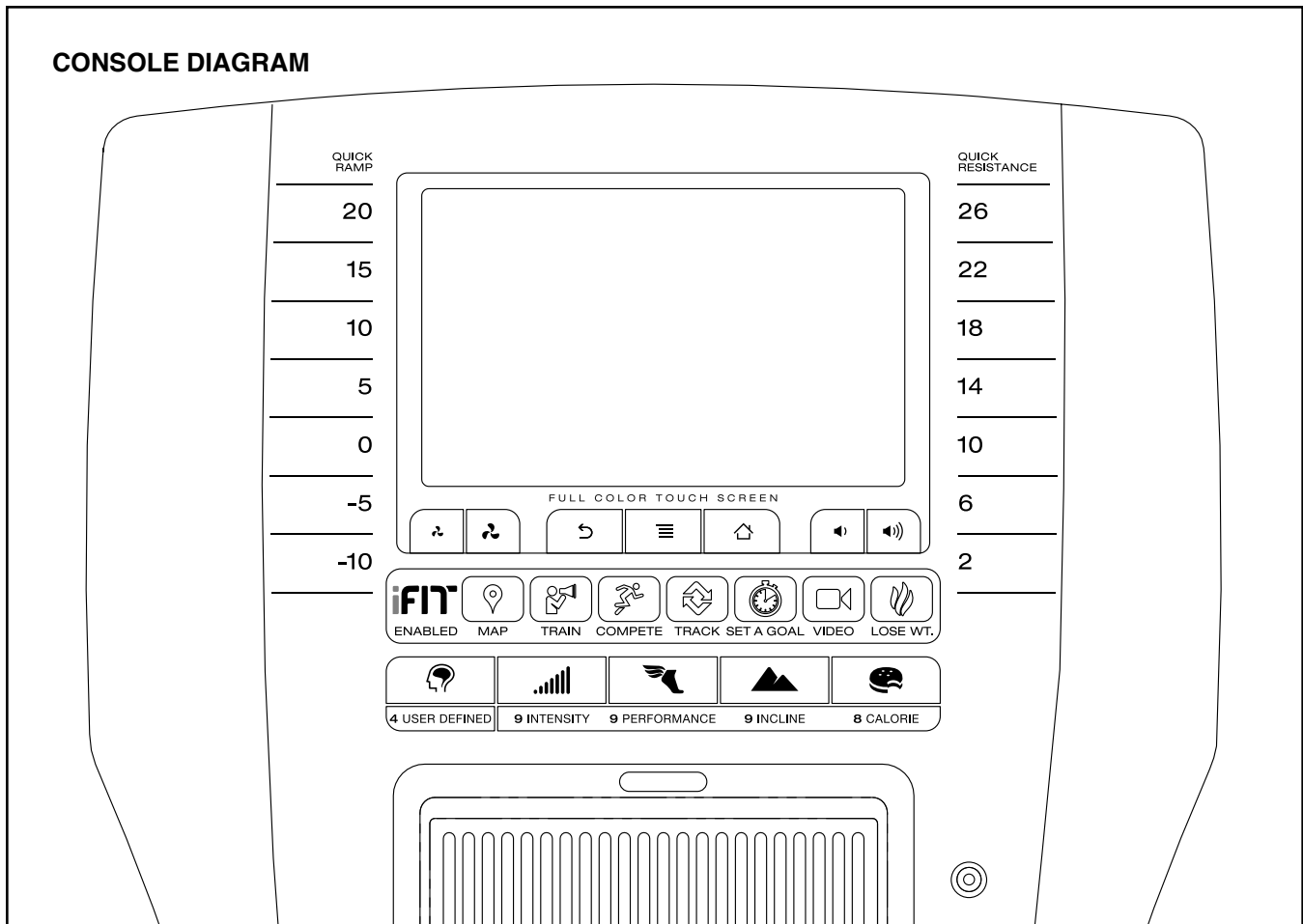

FEATURES OF THE CONSOLE

The advanced console offers an array of features designed to make your workouts more effective and enjoyable.

The console features revolutionary iFit technology that enables the console to communicate with your wireless network. With iFit technology, you can download personalized workouts, create your own workouts, track your workout results, and access many other features.

See www.iFit.com for complete information.

In addition, the console features a selection of onboard workouts designed to work different muscle groups. Each onboard workout automatically changes the resistance of the pedals and the incline of the ramp and prompts you to vary your pedaling speed as it guides you through an effective workout. You can also set a time, distance, calorie, or rpm goal. Several iFit demo workouts are also included.

The console also offers user-defined workouts that allow you to create your own workouts and store them in memory for future use.

When you use the manual mode of the console, you can change the resistance of the pedals and the incline of the ramp with the touch of a button. While you exercise, the console will display continuous exercise feedback. You can also measure your heart rate using the handgrip heart rate monitor or the chest heart rate monitor.

You can even browse the Internet or listen to your favorite workout music or audio books with the console sound system while you exercise.

Note: The console can display distance in either miles or kilometers. To find which unit of measurement is selected, see step 8 on page 30.

HOW TO TURN ON THE POWER

IMPORTANT: If the elliptical has been exposed to cold temperatures, allow it to warm to room temperature before you turn on the power. If you do not do this, you may damage the console displays or other electrical components.

Plug in the power cord (see HOW TO PLUG IN THE POWER CORD on page 17). Next, locate the power switch on the frame near the power cord. Press the power switch to the reset position.

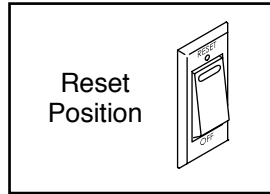

The screen will then turn on and the console will be ready for use.

Note: When you turn on the power for the first time, the incline of the ramp may calibrate automatically. The ramp will move upward and downward as it calibrates. When the ramp stops moving, the ramp is calibrated.

IMPORTANT: If the ramp does not calibrate automatically, see step 4 on page 31 and calibrate the ramp manually.

HOW TO USE THE TOUCH SCREEN

The console features a tablet with a full-color touch screen. The following information will help you become familiar with the device's advanced technology:

- The console functions similarly to other tablets. You can slide or flick your finger against the screen to move certain images on the screen, such as the displays in a workout (see step 4 on page 23). However, you cannot zoom in and out by sliding your fingers on the screen.
- The screen is not pressure-sensitive. You do not need to press hard on the screen.
- To type information into a text box, touch the text box to view the keyboard. To use numbers or other characters on the keyboard, touch the ?123 button. To view more characters, touch the Alt button. Touch the Alt button again to return to the number keyboard. To return to the letter keyboard, touch the ABC button. To use a capital character, touch the button with an upward-facing arrow. To use multiple capital characters, touch the arrow button again. To return to the lowercase keyboard, touch the arrow button a third time. To clear the last character, touch the button with a backward-facing arrow and an X.
- Use the buttons at the bottom of the screen to navigate the console menus. Touch the back button to return to the previous screen. Touch the home button to return to the main menu. Touch the runner button to select the onboard workouts menu. Touch the globe button to select the Internet browser. Touch the gears button to select the settings menu. Touch the Login button to log in to iFit.
- Use the buttons on the console to navigate the tablet. Press the Home button to access the tablet desktop. Press the Back button to return to the previous screen. The center button does not function.

HOW TO SET UP THE CONSOLE

Before using the elliptical for the first time, set up the console.

1. Connect to your wireless network.

Note: In order to access the Internet, download iFit workouts, and use some other features of the console, you must be connected to a wireless network. See HOW TO USE THE WIRELESS NETWORK MODE on page 32 to connect the console to your wireless network.

2. Check for firmware updates.

First, see step 1 on page 30 and step 2 on page 31 and select the maintenance mode. Then, see step 3 on page 31 and check for firmware updates.

3. Calibrate the incline of the ramp.

See step 4 on page 31 and calibrate the incline of the ramp.

4. Create an iFit account.

Touch the globe button near the lower-left corner of the screen and then touch the iFit button.

Note: For information about navigating in the Internet browser, see page 33.

The Internet browser will open to the iFit.com home page. Touch the Register button in the upper-right corner of the screen.

The browser will open to the iFit.com registration page. Touch the Buy Now button to register for an iFit account. If you have an activation code, select the code activation option. Then, follow the prompts on the screen to sign up for your iFit membership.

The console is now ready for you to begin working out. The following pages explain the various workouts and other features that the console offers.

To use the manual mode, see page 23. **To use an onboard workout**, see page 25. **To use a set-a-goal workout**, see page 26. **To create a user-defined workout**, see page 27. **To use a user-defined workout**, see page 28. **To use an iFit workout**, see page 29.

To use the equipment settings mode, see page 30. **To use the maintenance mode**, see page 31. **To use the wireless network mode**, see page 32. **To use the sound system**, see page 33. **To use the Internet browser**, see page 33.

Note: If there is a sheet of plastic on the screen, remove the plastic.

HOW TO USE THE MANUAL MODE

1. Touch the screen or press any button on the console to turn on the console.

See HOW TO TURN ON THE POWER on page 21.

2. Select the main menu.

When you turn on the console, the main menu will appear on the screen after the console boots up.

Touch the home button in the lower-left corner of the screen to return to the main menu at any time.

3. Change the resistance of the pedals and the incline of the ramp as desired.

Press the Start button or begin pedaling.

As you pedal, you can change the resistance of the pedals. To change the resistance, press one of the numbered Quick Resistance buttons or press the Resistance increase and decrease buttons located on the right handlebar.

Note: After you press a button, it will take a moment for the pedals to reach the selected resistance level.

To vary the motion of the pedals, you can change the incline of the ramp. To change the incline, press one of the numbered Quick Ramp buttons or press the Ramp increase and decrease buttons located on the left handlebar.

Note: After you press a button, it will take a moment for the ramp to reach the selected incline level.

4. Follow your progress.

The console offers several display modes. The display mode that you select will determine which workout information is shown.

To select the desired display mode, simply flick or slide the screen. You can also view additional workout information by touching the red boxes on the screen.

If desired, keep your pedaling speed near the target rpm. The target zone meter will prompt you to increase, decrease, or maintain your pedaling speed.

If desired, adjust the volume level by pressing the volume increase and decrease buttons on the console.

To pause the workout, touch one of the menu buttons on the screen. To continue the workout, touch the Resume button. To end the workout session, touch the End Workout button.

The elliptical features an ultrasonic sensor that can detect an object behind the elliptical. To enable or disable the ultrasonic sensor, see step 11 on page 30. If the ultrasonic sensor detects an object, one or more messages will appear on the screen to alert you. If the object is in the zone closest to the elliptical, the resistance of the pedals will also automatically increase.

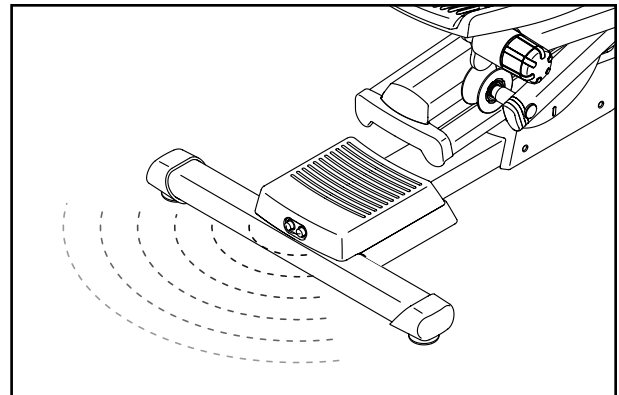

5. Measure your heart rate if desired.

To use the chest heart rate monitor, see page 16. To use the handgrip heart rate monitor, follow the instructions below. **IMPORTANT: If you use both heart rate monitors at the same time, the console will not display your heart rate accurately.**

If there are sheets of plastic on the metal contacts on the handgrip heart rate monitor, remove the plastic. To measure your heart rate, hold the handgrip heart rate monitor with your palms resting against the contacts. **Avoid moving your hands or gripping the contacts tightly.**

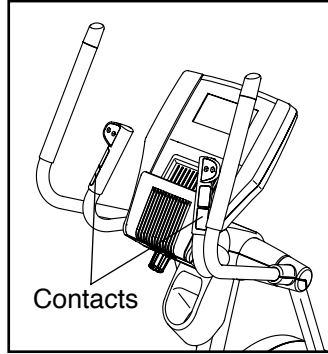

When your pulse is detected, your heart rate will be shown. For the most accurate heart rate reading, hold the contacts for at least 15 seconds.

If the display does not show your heart rate, make sure that your hands are positioned as described. Be careful not to move your hands excessively or to squeeze the contacts tightly. For optimal performance, clean the contacts using a soft cloth; **never use alcohol, abrasives, or chemicals to clean the contacts.**

6. Turn on the fan if desired.

The fan has several speed settings, including an auto mode. While the auto mode is selected, the speed of the fan will automatically increase or decrease as you increase or decrease your pedaling speed. Press the fan increase and decrease buttons repeatedly to select a fan speed or to turn off the fan.

Note: If the pedals are not moved for a while when the main menu is selected, the fan will turn off automatically.

7. When you are finished exercising, unplug the power cord.

When you are finished exercising, press the power switch to the off position and unplug the power cord. **IMPORTANT: If you do not do this, the electrical components of the elliptical may wear prematurely.**

HOW TO USE AN ONBOARD WORKOUT

1. Touch the screen or press any button on the console to turn on the console.

See HOW TO TURN ON THE POWER on page 21.

2. Select an onboard workout.

To select an onboard workout, touch the runner button in the lower left corner of the screen. The workouts menu will appear on the screen.

Note: You can also press the Intensity, Performance, Incline, and Calorie buttons on the console.

Select the desired workout category from the workouts menu and then, select the desired workout. The screen will show the name, duration, and distance of the workout. The screen will also show the approximate number of calories you will burn during the workout and a profile of the resistance settings of the workout.

3. Start the workout.

Touch the Start Workout button to start the workout.

Each workout is divided into segments. One resistance level, one ramp incline level, and one target rpm (speed) are programmed for each segment. Note: The same resistance level, ramp incline level, and/or target rpm may be programmed for consecutive segments.

During the workout, the profiles will show your progress. To view the profiles, flick or slide the screen. The vertical colored line will indicate the current segment of the workout. The lower profile represents the incline level of the current segment. The upper profile represents the resistance level of the current segment.

As you exercise, keep your pedaling speed near the target rpm for the current segment. The target zone meter will prompt you to increase, decrease, or maintain your pedaling speed. To view the target zone meter, flick or slide the screen.

IMPORTANT: The target rpm is intended only to provide motivation. Your actual pedaling speed may be slower than the target rpm. Make sure to pedal at a speed that is comfortable for you.

If the resistance level or incline level for the current segment is too high or too low, you can manually override the setting by pressing the Quick Resistance buttons or the Quick Ramp buttons.

IMPORTANT: When the current segment of the workout ends, the pedals will automatically adjust to the resistance level programmed for the next segment and the ramp will automatically adjust to the incline level programmed for the next segment.

Note: The calorie goal is an estimate of the number of calories that you will burn during the workout. The actual number of calories that you burn will depend on various factors such as your weight. In addition, if you manually change the resistance or incline of the ramp during the workout, the number of calories you burn will be affected.

To pause the workout, touch either the back button or the home button at the bottom of the screen. To continue the workout, touch the Resume button. To end the workout, touch the End Workout button.

The workout will continue in this way until the last segment ends. A workout summary will appear on the screen. After you view the workout summary, touch the Finish button to return to the main menu. You may also be able to either save or publish your results using one of the options on the screen.

4. Follow your progress.

See step 4 on page 23.

5. Measure your heart rate if desired.

See step 5 on page 24.

6. Turn on the fan if desired.

See step 6 on page 24.

7. When you are finished exercising, unplug the power cord.

See step 7 on page 24.

HOW TO USE A SET-A-GOAL WORKOUT

1. Touch the screen or press any button on the console to turn on the console.

See HOW TO TURN ON THE POWER on page 21.

2. Select the main menu.

See step 2 on page 23.

3. Select a set-a-goal workout.

To select a set-a-goal workout, touch the Set A Goal button on the screen or press the Set A Goal button on the console.

To set a time, distance, calorie, or rpm goal, touch the Time, Distance, Calories, or RPM button. Then, touch the increase and decrease buttons on the screen to select a time, distance, calorie, or rpm goal and to select the resistance and incline levels for the workout. The screen will show the duration and distance of the workout, and the approximate number of calories you will burn during the workout.

4. Start the workout.

Touch the Start button to start the workout.

The workout will function in the same way as the manual mode (see page 23).

The workout will continue until you reach the goal that you set. A workout summary will appear on the screen. After you view the workout summary, touch the Finish button to return to the main menu. You may also be able to either save or publish your results using one of the options on the screen.

Note: The calorie goal is an estimate of the number of calories that you will burn during the workout. The actual number of calories that you burn will depend on various factors such as your weight.

5. Follow your progress.

See step 4 on page 23.

6. Measure your heart rate if desired.

See step 5 on page 24.

7. Turn on the fan if desired.

See step 6 on page 24.

8. When you are finished exercising, unplug the power cord.

See step 7 on page 24.

HOW TO CREATE A USER-DEFINED WORKOUT

1. Touch the screen or press any button on the console to turn on the console.

See HOW TO TURN ON THE POWER on page 21.

2. Select a user-defined workout.

To select a user-defined workout, press the User Defined button on the console.

Select the desired workout from the user-defined workouts menu. Then, touch the Record New button.

3. Start the workout.

Each workout is divided into segments. You can program one resistance level and one ramp incline level for each segment.

To program a resistance level for the first segment, simply adjust the resistance of the pedals by pressing the Quick Resistance buttons.

To program a ramp incline level for the first segment, simply adjust the incline of the ramp by pressing the Quick Ramp buttons.

At the end of the first segment, the workout will store the current resistance level and ramp incline level in memory.

Program a resistance level and a ramp incline level for the second segment as described above.

Continue exercising for as long as desired. Stop pedaling when you are finished with your workout. The workout that you created will then be stored in memory.

A workout summary will appear on the screen. After you view the workout summary, touch the Finish button to return to the main menu. You may also be able to either save or publish your results using one of the options on the screen.

4. When you are finished exercising, unplug the power cord.

See step 7 on page 24.

HOW TO USE A USER-DEFINED WORKOUT

1. **Touch the screen or press any button on the console to turn on the console.**

See HOW TO TURN ON THE POWER on page 21.

2. **Select a user-defined workout.**

To select a user-defined workout, press the User Defined button on the console.

Select the desired workout from the user-defined workouts menu. Then, touch the Repeat button.

Note: To create a user-defined workout, touch the Record New button. See HOW TO CREATE A USER-DEFINED WORKOUT on page 27.

The screen will show the name, duration, and distance of the workout. The screen will also show the approximate number of calories you will burn during the workout and a profile of the resistance settings of the workout.

3. **Start the workout.**

Touch the Start Workout button to start the workout.

Each workout is divided into segments. One resistance level and one ramp incline level are programmed for each segment. Note: The same resistance level and/or ramp incline level may be programmed for consecutive segments.

During the workout, the profiles will show your progress. To view the profiles, flick or slide the screen. The vertical colored line will indicate the current segment of the workout. The lower profile represents the incline level of the current segment. The upper profile represents the resistance level of the current segment.

If the resistance level or incline level for the current segment is too high or too low, you can manually override the setting by pressing the Quick Resistance buttons or the Quick Ramp buttons.

IMPORTANT: When the current segment of the workout ends, the pedals will automatically adjust to the resistance level programmed for the next segment and the ramp will automatically adjust to the incline level programmed for the next segment.

Note: The calorie goal is an estimate of the number of calories that you will burn during the workout. The actual number of calories that you burn will depend on various factors such as your weight. In addition, if you manually change the resistance or incline of the ramp during the workout, the number of calories you burn will be affected.

To pause the workout, touch either the back button or the home button at the bottom of the screen. To continue the workout, touch the Resume button. To end the workout, touch the End Workout button.

The workout will continue in this way until the last segment ends. A workout summary will appear on the screen. After you view the workout summary, touch the Finish button to return to the main menu. You may also be able to either save or publish your results using one of the options on the screen.

4. **Change the workout if desired.**

If desired, you can change the workout. See HOW TO CREATE A USER-DEFINED WORKOUT on page 27.

5. **Follow your progress.**

See step 4 on page 23.

6. **Measure your heart rate if desired.**

See step 5 on page 24.

7. **Turn on the fan if desired.**

See step 6 on page 24.

8. **When you are finished exercising, unplug the power cord.**

See step 7 on page 24.

HOW TO USE AN iFIT LIVE WORKOUT

Note: To use an iFit workout, you must have access to a wireless network (see HOW TO USE THE WIRELESS NETWORK MODE on page 32). An iFit account is also required.

1. Touch the screen or press any button on the console to turn on the console.

See HOW TO TURN ON THE POWER on page 21.

2. Select the main menu.

See step 2 on page 23.

3. Log in to your iFit account.

If you have not already done so, touch the Login button to log in to your iFit account. The screen will ask for your iFit.com username and password. Enter them and touch the Login button. Touch the Cancel button to exit the login screen.

4. Select an iFit workout.

To download an iFit workout in your schedule, touch the Map, Train, Video, or Lose Weight button to download the next workout of that type in your schedule. Note: You may be able to access demo workouts through these options, even if you do not log in to an iFit account.

To compete in a race that you have previously scheduled, touch the Compete button. To view your Workout History, touch the Track button. To use a set-a-goal workout, touch the Set A Goal button (see page 26). Note: You can also press one of the iFit buttons on the console.

To switch users within the account, touch the user button at the bottom of the screen.

Note: Before some workouts will download, you must add them to your schedule on iFit.com.

For more information about the iFit workouts, please see www.iFit.com.

When you select an iFit workout, the screen will show the name, duration, and distance of the workout. The screen will also show the approximate number of calories you will burn during the workout. If you select a competition workout, the display will count down to the beginning of the race.

5. Start the workout.

See step 3 on page 25.

During some workouts, the voice of a personal trainer will guide you through your workout.

6. Follow your progress.

See step 4 on page 23. The screen may also show a map of the trail you are walking or running.

During a competition workout, the screen will show the speeds of the racers and the distances they have traveled. The screen will also show the numbers of seconds that the other racers are ahead of you or behind you.

7. Measure your heart rate if desired.

See step 5 on page 24.

8. Turn on the fan if desired.

See step 6 on page 24.

9. When you are finished exercising, unplug the power cord.

See step 7 on page 24.

For more information about the iFit mode, go to www.iFit.com.

HOW TO USE THE EQUIPMENT SETTINGS MODE

1. Select the settings main menu.

Turn on the console and select the main menu (see steps 1 and 2 on page 23). Then, touch the gears button at the bottom of the screen to select the settings main menu.

2. Select the equipment settings mode.

In the settings main menu, touch the Equipment Settings button.

Note: It may be necessary to scroll the screen to view all the menu options.

3. Select a language.

To select a language, touch the Language button and select the desired language. Note: This feature may not be enabled.

4. Select a time zone.

To select a time zone, touch the Timezone button and select the desired time zone. Then, touch the back button on the screen.

5. Turn on or turn off the display demo mode.

The console features a display demo mode, designed to be used if the elliptical is displayed in a store. While the demo mode is turned on, the screen will show a demo presentation.

To turn on or turn off the display demo mode, first touch the Demo Mode button. Next, touch the On checkbox or the Off checkbox. Then, touch the back button on the screen.

6. Enable or disable a passcode.

The console features a child safety passcode, designed to prevent unauthorized users from using the elliptical.

Touch the Passcode button. To enable a passcode, touch the Enable checkbox. Then, enter a 4-digit passcode of your choice. Touch Save to use this passcode. Touch Cancel to return to the equipment settings mode and not use a passcode. To disable the passcode, touch the Disable checkbox.

Note: If a passcode is enabled, the console will regularly ask for you to enter the passcode. The console will remain locked until the correct passcode is entered. **IMPORTANT: If you forget your passcode, enter the following master passcode to unlock the console: 1985.**

7. Enable or disable the Internet browser.

To enable or disable the Internet browser, first touch the Browser button. Next, touch the Enable checkbox or the Disable checkbox. Then, touch the back button on the screen.

8. Select the unit of measurement.

Touch the US/Metric button to view the selected unit of measurement. Next, touch the checkbox for the desired unit of measurement. Then, touch the back button on the screen.

9. Select an update time.

To select a time for automatic console updates, touch the Update Time button and select the desired time. Then, touch the back button on the screen.

IMPORTANT: You must still unplug the power cord after using your elliptical. Set the update time for a time when you normally use your elliptical and will be available to unplug the power cord after an update.

10. Enable or disable the safety key.

This feature is not enabled on your elliptical. Your elliptical does not have a safety key.

11. Enable or disable the ultrasonic sensor.

The elliptical features an ultrasonic sensor that can detect an object behind the elliptical. If the ultrasonic sensor detects an object, one or more messages will appear on the screen to alert you. If the object is in the zone closest to the elliptical, the resistance of the pedals will also automatically increase. To enable or disable the ultrasonic sensor, first touch the Safety Zone button. Next, touch the Enable checkbox or the Disable checkbox. Then, touch the back button on the screen.

12. Enable or disable street view.

During some workouts, the screen may show a map. To enable or disable the street view feature of the maps, first touch the Street View button. Next, touch the Enable checkbox or the Disable checkbox. Then, touch the back button on the screen.

13. Exit the equipment settings mode.

To exit the equipment settings mode, touch the back button on the screen.

HOW TO USE THE MAINTENANCE MODE

1. Select the settings main menu.

See step 1 on page 30.

2. Select the maintenance mode.

In the settings main menu, touch the Maintenance button to enter the maintenance mode.

The maintenance mode main screen will show information about the console and the wireless network.

3. Update the console firmware.

For the best results, regularly check for firmware updates.

Touch the Firmware Update button to check for firmware updates using your wireless network. The update will begin automatically.

IMPORTANT: To avoid damaging the elliptical, do not turn off the power while the firmware is being updated.

The screen will show the progress of the update. When the update is complete, the elliptical will turn off and then turn back on. If it does not, press the power switch into the off position. Wait for several seconds, and then press the power switch into the reset position. Note: It may take a few minutes for the console to be ready for use.

4. Calibrate the incline of the ramp.

Touch the Calibrate Incline button. Then, touch the Begin button to calibrate the incline of the ramp. The ramp will automatically rise to the maximum incline level, lower to the minimum incline level, and then return to the starting position. This will calibrate the incline. Press the Cancel button to return to the maintenance mode. When the incline is calibrated, touch the Finish button.

IMPORTANT: Keep pets, feet, and other objects away from the elliptical while the incline is calibrating.

5. View machine information.

Touch the Machine Info button to view information about your elliptical. After you view the information, touch the back button on the screen.

6. Find keycodes.

This option is intended to be used by service technicians to identify whether a certain button is working correctly.

7. Exit the maintenance mode.

To exit the maintenance mode, press the back button on the console.

HOW TO USE THE WIRELESS NETWORK MODE

The console features a wireless network mode that allows you to set up a wireless network connection.

1. Select the settings main menu.

See step 1 on page 30.

2. Select the wireless network mode.

In the settings main menu, touch the Wireless Network button to enter the wireless network mode.

3. Enable Wi-Fi.

Make sure that the Wi-Fi checkbox is marked with a green checkmark. If it is not, touch the Wi-Fi menu option once and wait for a few seconds. The console will search for available wireless networks.

4. Set up and manage a wireless network connection.

When Wi-Fi is enabled, the screen will show a list of available networks. Note: It may take several seconds for the list of wireless networks to appear.

Make sure that the checkbox on the Network notification menu option is marked with a green checkmark to have the console notify you when a wireless network is within range and available.

Note: You must have your own wireless network and a wireless router (802.11b/g or 802.11b/g/n) with SSID broadcast enabled (hidden networks are not supported).

When a list of networks appears, touch the desired network. Note: You will need to know your network name (SSID). If your network has a password, you will also need to know the password.

An information box will ask if you want to connect to the wireless network. Touch the Connect button to connect to the network or touch the Cancel button to return to the list of networks. If the network has a password, touch the password entry box. A keyboard will appear on the screen. To view the password as you type it, touch the Show Password checkbox.

To use the keyboard, see HOW TO USE THE TOUCH SCREEN on page 21.

When the console is connected to your wireless network, the WiFi menu option at the top of the screen will display the word CONNECTED. Then, touch the back button on the screen to return to the wireless network mode.

To disconnect from a wireless network, select the wireless network and then touch the Forget button.

If you are having problems connecting to an encrypted network, make sure that your password is correct. Note: Passwords are case-sensitive.

Note: The iFit mode supports unsecured and secured (WEP, WPA, and WPA2) encryption. A broadband connection is recommended; performance depends on connection speed.

Note: If you have questions after following these instructions, go to support.ifit.com for assistance.

5. Exit the wireless network mode.

To exit the wireless network mode, press the back button on the console.

HOW TO USE THE SOUND SYSTEM

To play music or audio books through the console sound system, you must connect your MP3 player, CD player, or other personal audio player to the console.

Plug one end of your audio wire into the audio jack on the console. Then, plug the other end into a jack on your MP3 player, CD player, or other personal audio player. **Make sure that your audio wire is fully plugged in.**

Next, press the play button on your MP3 player, CD player, or other personal audio player. Then, adjust the volume level on your personal audio player or press the volume increase and decrease buttons on the console.

If you are using a personal CD player and the CD skips, set the CD player on the floor or another flat surface instead of on the console.

HOW TO USE THE INTERNET BROWSER

Note: To use the Internet browser, you must have access to a wireless network including a wireless router (802.11b/g or 802.11b/g/n) with SSID broadcast enabled (hidden networks are not supported).

To open the Internet browser, touch the globe button at the bottom of the screen. Then, select a website.

To return to the previous web page, touch the Browser Back button on the screen. To exit the Internet browser, touch the Return button on the screen.

To use the keyboard, see HOW TO USE THE TOUCH SCREEN on page 21.

To enter a different web address in the URL bar, first, slide your finger down the screen to view the URL bar, if necessary. Then, touch the URL bar, use the keyboard to enter the address, and touch the Go button.

Note: While you are using the Internet browser, the resistance, ramp, fan, and volume buttons will still function, but the workout buttons will not function.

Note: If you have questions after following these instructions, go to support.ifit.com for assistance.

FCC INFORMATION

This equipment has been tested and found to comply with the limits for a Class B digital device, pursuant to part 15C and part 18 of the FCC Rules. These limits are designed to provide reasonable protection against harmful interference in a residential installation. This equipment generates, uses, and can radiate radio frequency energy and, if not installed and used in accordance with the instructions, may cause harmful interference to radio communications. However, there is no guarantee that interference will not occur in a particular installation. If this equipment does cause harmful interference to radio or television reception, which can be determined by turning the equipment off and on, try to correct the interference by one or more of the following measures:

- Reorient or relocate the receiving antenna.
- Increase the separation between the equipment and the receiver.
- Connect the equipment into an outlet on a circuit different from that to which the receiver is connected.
- Consult the dealer or an experienced radio/TV technician for help.

FCC CAUTION: To assure continued compliance, use only shielded interface cables when connecting to computer or peripheral devices. Changes or modifications not expressly approved by the party responsible for compliance could void the user's authority to operate this equipment.

IMPORTANT: To satisfy exposure compliance requirements, the antenna and transmitter in the console must be at least 8 in. (20 cm) from all persons and must not be near or connected to any other antenna or transmitter.

Note: The console contains FCC ID: OMC310900.

MAINTENANCE AND TROUBLESHOOTING

IMPORTANT: Servicing other than the procedures described below should be performed only by an authorized service representative.

Inspect and tighten all parts of the elliptical regularly. Replace any worn parts immediately.

To clean the elliptical, **first press the power switch to the off position and unplug the power cord.** Wipe exterior parts of the elliptical with a damp cloth and a few drops of mild dish soap. Then, wipe the elliptical with a cloth dampened with clean water, and dry the elliptical with a soft towel. **IMPORTANT: Do not spray liquid directly onto the console or onto other parts of the elliptical. To avoid damage to the console, keep the console out of direct sunlight.**

CONSOLE TROUBLESHOOTING

If the console does not display your heart rate when you hold the handgrip heart rate monitor, or if the displayed heart rate appears to be too high or too low, see step 5 on page 24.

If the console does not display your heart rate when you use the chest heart rate monitor, see TROUBLESHOOTING on page 16.

HOW TO ADJUST THE DRIVE BELT

If the pedals slip while you are pedaling, even while the resistance is adjusted to the highest level, the drive belt may need to be adjusted.

Press the power switch to the off position and unplug the power cord.

To adjust the drive belt, first see assembly step 10 on page 10. Remove the Right Roller Arm (45) from the Right Pedal Arm (58).

Next, see EXPLODED DRAWING A on page 41 and EXPLODED DRAWING B on page 42. Remove the M8 x 16mm Screw (72), the Axle Cover (53), and the M8 x 25mm Washer (149) from the upper end of the Right Roller Arm (45). Then, remove the Right Roller Arm from the right Crank Arm (20). Set the Right Roller Arm out of the way.

Then, see assembly step 21 on page 15. Using a flat screwdriver, release the tabs on the Shield Cover (75) and slide it upward.

See EXPLODED DRAWING C on page 43. Remove all the M4 x 16mm Screws (104) from the Right Front Shield (74). Next, remove the M4 x 22mm Screw (127) from the Left Front Shield (73). Then, gently remove the Right Front Shield.

Locate and loosen the Idler Screw (101). Next, tighten the Belt Adjustment Screw (88) until the Drive Belt (113) is tight. Then, retighten the Idler Screw.

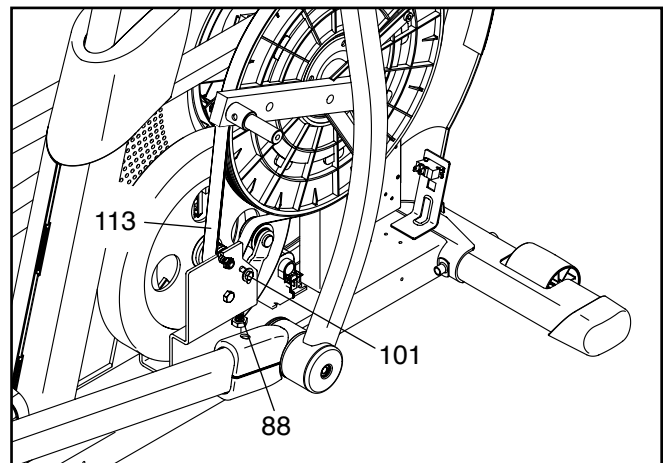

Reattach the right front shield, the shield cover, and the right roller arm.

HOW TO ADJUST THE REED SWITCH

If the console does not display correct feedback, the reed switch should be adjusted.

Press the power switch to the off position and unplug the power cord.

To adjust the reed switch, first see assembly step 10 on page 10. Remove the Left Roller Arm (12) from the Left Pedal Arm (44).

Next, see EXPLODED DRAWING A on page 41 and EXPLODED DRAWING B on page 42. Remove the M8 x 16mm Screw (72), the Axle Cover (53), and the M8 x 25mm Washer (149) from the upper end of the Left Roller Arm (12). Then, remove the Left Roller Arm from the left Crank Arm (20). Set the Left Roller Arm out of the way.

See EXPLODED DRAWING C on page 43. Using a flat screwdriver, pry the left Crank Arm Cover (71) off the Left Front Shield (73).

Next, locate the Reed Switch (38). Turn the left Crank Arm (20) until one of the Magnets (43) on the Pulley (19) is aligned with the Reed Switch.

Loosen, but do not remove, the two M4 x 16mm Screws (104). Slide the Reed Switch (38) slightly closer to or away from the Magnet (43). Then, retighten the Screws. Plug in the power cord and press the power switch to the reset position. Turn the left Crank Arm (20) for a moment.

Repeat these actions until the console displays correct feedback. Then, reattach the left crank arm cover and the left roller arm.

STORAGE

If the elliptical will not be used for an extended period of time, lay the power cord over the elliptical where it will not be pinched or crushed, and cover the elliptical to keep it free of dust. Store the elliptical indoors. Do not store objects on the elliptical.

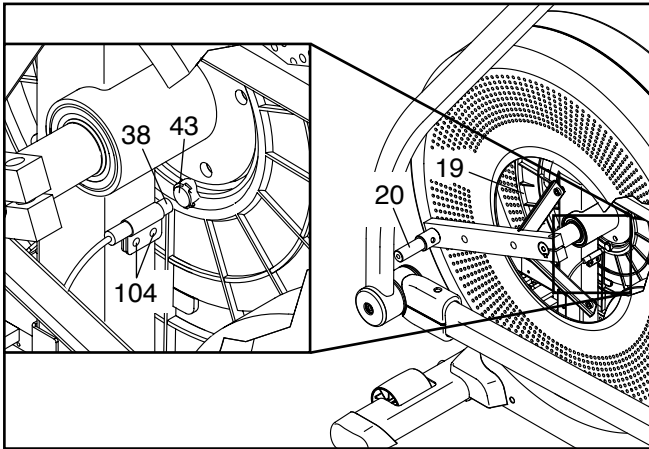

EXERCISE GUIDELINES

⚠️ WARNING: Before beginning this or any exercise program, consult your physician. This is especially important for persons over age 35 or persons with pre-existing health problems.

The heart rate monitor is not a medical device. Various factors may affect the accuracy of heart rate readings. The heart rate monitor is intended only as an exercise aid in determining heart rate trends in general.

These guidelines will help you to plan your exercise program. For detailed exercise information, obtain a reputable book or consult your physician. Remember, proper nutrition and adequate rest are essential for successful results.

EXERCISE INTENSITY

Whether your goal is to burn fat or to strengthen your cardiovascular system, exercising at the proper intensity is the key to achieving results. You can use your heart rate as a guide to find the proper intensity level. The chart below shows recommended heart rates for fat burning and aerobic exercise.

165	155	145	140	130	125	115	❤️
145	138	130	125	118	110	103	❤️
125	120	115	110	105	95	90	❤️
<hr/>							
20	30	40	50	60	70	80	

To find the proper intensity level, find your age at the bottom of the chart (ages are rounded off to the nearest ten years). The three numbers listed above your age define your “training zone.” The lowest number is the heart rate for fat burning, the middle number is the heart rate for maximum fat burning, and the highest number is the heart rate for aerobic exercise.

Burning Fat—To burn fat effectively, you must exercise at a low intensity level for a sustained period of time. During the first few minutes of exercise, your body uses carbohydrate calories for energy. Only after the first few minutes of exercise does your body begin to use stored fat calories for energy. If your goal is to burn fat, adjust the intensity of your exercise until your heart rate is near the lowest number in your training zone. For maximum fat burning, exercise with your heart rate near the middle number in your training zone.

Aerobic Exercise—If your goal is to strengthen your cardiovascular system, you must perform aerobic exercise, which is activity that requires large amounts of oxygen for prolonged periods of time. For aerobic exercise, adjust the intensity of your exercise until your heart rate is near the highest number in your training zone.

WORKOUT GUIDELINES

Warming Up—Start with 5 to 10 minutes of stretching and light exercise. A warm-up increases your body temperature, heart rate, and circulation in preparation for exercise.

Training Zone Exercise—Exercise for 20 to 30 minutes with your heart rate in your training zone. (During the first few weeks of your exercise program, do not keep your heart rate in your training zone for longer than 20 minutes.) Breathe regularly and deeply as you exercise; never hold your breath.

Cooling Down—Finish with 5 to 10 minutes of stretching. Stretching increases the flexibility of your muscles and helps to prevent post-exercise problems.

EXERCISE FREQUENCY

To maintain or improve your condition, complete three workouts each week, with at least one day of rest between workouts. After a few months of regular exercise, you may complete up to five workouts each week, if desired. Remember, the key to success is to make exercise a regular and enjoyable part of your everyday life.

SUGGESTED STRETCHES

The correct form for several basic stretches is shown at the right. Move slowly as you stretch; never bounce.

1. Toe Touch Stretch

Stand with your knees bent slightly and slowly bend forward from your hips. Allow your back and shoulders to relax as you reach down toward your toes as far as possible. Hold for 15 counts, then relax. Repeat 3 times. Stretches: Hamstrings, back of knees and back.

2. Hamstring Stretch

Sit with one leg extended. Bring the sole of the opposite foot toward you and rest it against the inner thigh of your extended leg. Reach toward your toes as far as possible. Hold for 15 counts, then relax. Repeat 3 times for each leg. Stretches: Hamstrings, lower back and groin.

3. Calf/Achilles Stretch

With one leg in front of the other, reach forward and place your hands against a wall. Keep your back leg straight and your back foot flat on the floor. Bend your front leg, lean forward and move your hips toward the wall. Hold for 15 counts, then relax. Repeat 3 times for each leg. To cause further stretching of the achilles tendons, bend your back leg as well. Stretches: Calves, achilles tendons and ankles.

4. Quadriceps Stretch

With one hand against a wall for balance, reach back and grasp one foot with your other hand. Bring your heel as close to your buttocks as possible. Hold for 15 counts, then relax. Repeat 3 times for each leg. Stretches: Quadriceps and hip muscles.

5. Inner Thigh Stretch

Sit with the soles of your feet together and your knees outward. Pull your feet toward your groin area as far as possible. Hold for 15 counts, then relax. Repeat 3 times. Stretches: Quadriceps and hip muscles.

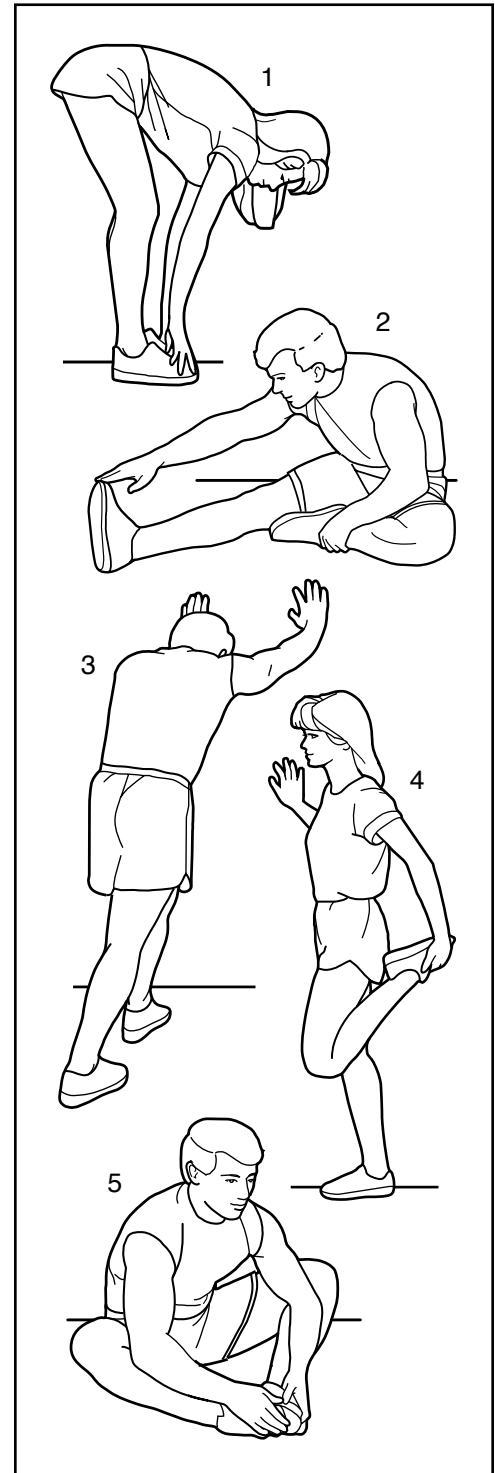

PART LIST

Model No. EPEL12912.1 R1112A

Key No.	Qty.	Description	Key No.	Qty.	Description
1	1	Frame	51	2	Roller
2	1	Rear Stabilizer Cover	52	1	Console Knob
3	1	Ramp	53	6	Axle Cover
4	1	Upright	54	1	Left Arm Upper Cover
5	1	Rear Stabilizer	55	1	Left Arm Lower Cover
6	1	Front Stabilizer	56	1	Upper Handlebar Cover
7	1	Console	57	8	Roller Arm/Pedal Arm Bushing
8	1	Accessory Tray Base/Receiver	58	1	Right Pedal Arm
9	2	Ramp Side Cover	59	4	Flex Bracket Bushing
10	1	Ramp Top Cover	60	1	Lower Handlebar Cover
11	1	Left Track	61	1	Right Upper Body Arm
12	1	Left Roller Arm	62	1	Console Bracket
13	1	Lift Motor	63	1	Right Control/Wire Harness
14	1	Left Pedal	64	1	Console Knob Cap
15	1	Control Board	65	1	Ramp Axle
16	1	Power Switch	66	1	Handlebar Axle
17	1	Square Grommet	67	1	Right Arm Upper Cover
18	1	Crank	68	1	Right Arm Lower Cover
19	1	Pulley	69	1	Left Control/Wire Harness
20	2	Crank Arm	70	4	Upper Body Leg Bushing
21	2	Roller Arm Cap	71	2	Crank Arm Cover
22	1	Idler	72	33	M8 x 16mm Screw
23	2	Front Stabilizer Foot	73	1	Left Front Shield
24	2	Pedal Arm Axle	74	1	Right Front Shield
25	1	Resistance Motor	75	1	Shield Cover
26	4	Small Standoff	76	1	Left Rear Shield
27	2	M8 x 48mm Screw	77	1	Right Rear Shield
28	1	Eddy Mechanism	78	2	Key
29	1	Mechanism Axle	79	1	Console Rod
30	4	Frame/Upright Bushing	80	1	Lower Upright Cover
31	1	Lift Motor Lower Axle	81	1	Large Block
32	2	Lift Motor Spacer	82	2	M10 x 56mm Bolt
33	4	M10 x 16mm Screw	83	1	Right Handlebar
34	2	Wheel	84	2	M10 x 105mm Screw
35	1	Arm Axle	85	2	M10 x 54mm Bolt
36	1	Right Upper Body Leg	86	2	M6 x 12mm Screw
37	1	Accessory Tray	87	1	Left Handlebar
38	1	Reed Switch/Wire	88	1	Belt Adjustment Screw
39	1	Clamp	89	1	Pivot Screw
40	2	Frame Bearing	90	8	M6 Washer
41	2	Arm Grip	91	1	Upper Upright Cover
42	2	Large Snap Ring	92	4	Leveling Foot
43	2	Magnet	93	4	M4 x 12mm Screw
44	1	Left Pedal Arm	94	6	M8 Jam Nut
45	1	Right Roller Arm	95	2	Wave Washer
46	1	Left Upper Body Leg	96	4	M8 x 35mm Bolt
47	1	Left Upper Body Arm	97	1	Lift Motor Upper Axle
48	2	Arm Cap	98	12	M8 x 23mm Washer
49	1	Right Pedal	99	4	M10 Locknut
50	1	Small Block	100	4	M8 x 10mm Screw

Key No.	Qty.	Description	Key No.	Qty.	Description
101	1	Idler Screw	135	1	Left Pedal Adjustment Bracket
102	4	M8 Locknut	136	2	Pedal Arm Flex Bracket
103	1	Ultrasonic Sensor Bracket	137	8	Flex Bracket Cover
104	53	M4 x 16mm Screw	138	1	Left Pedal Plate
105	2	M8 x 16mm Hex Screw	139	1	Right Pedal Plate
106	1	Small Pulley Spacer	140	2	Pedal Plate Spring
107	4	Large Standoff	141	2	Pedal Knob Cap
108	2	M6 Small Washer	142	2	Pedal Knob
109	1	M6 Large Washer	143	1	Right Pedal Adjustment Bracket
110	1	Main Wire Harness	144	4	Pedal Arm Bushing
111	1	Large Pulley Spacer	145	2	Pedal Plate Screw
112	1	Power Cord	146	1	Receiver Wire Harness
113	1	Drive Belt	147	1	Ultrasonic Sensor
114	2	M2.6 x 12mm Screw	148	4	M10 x 25mm Washer
115	4	Track Screw	149	2	M8 x 25mm Washer
116	2	M10 x 108mm Bolt	150	2	M8 x 32mm Washer
117	14	Mount/Screw	151	4	M8 Split Washer
118	1	Control Board Bracket	152	2	Small Snap Ring
119	1	Ground Wire	153	2	Console Rod Nut
120	4	M8 x 18mm Bolt	154	1	Console Rod Washer
121	9	M6 x 14mm Screw	155	1	Sensor Wire Harness
122	2	Upright Bushing	156	5	Tree Fastener
123	1	M6 x 16mm Washer	157	2	Foam Pad
124	1	Right Track	158	2	Spring Sleeve
125	2	M6 x 12mm Screw	*	–	Blue Wire
126	1	Ground Screw	*	–	Green Wire
127	11	M4 x 22mm Screw	*	–	White Wire
128	2	Handlebar Bushing	*	–	Lift Motor Wire Harness A
129	2	M4 x 13mm Screw	*	–	Lift Motor Wire Harness B
130	1	Heart Rate Monitor	*	–	Resistance Motor Wire Harness
131	2	Lift Motor Bushing	*	–	Assembly Tool
132	2	Round Grommet	*	–	Grease Packet
133	4	Roller Arm Bushing	*	–	User's Manual
134	6	Stabilizer Cap			

Note: Specifications are subject to change without notice. For information about ordering replacement parts, see the back cover of this manual. *These parts are not illustrated.

EXPLODED DRAWING A

Model No. EPEL12912.1 R1112A

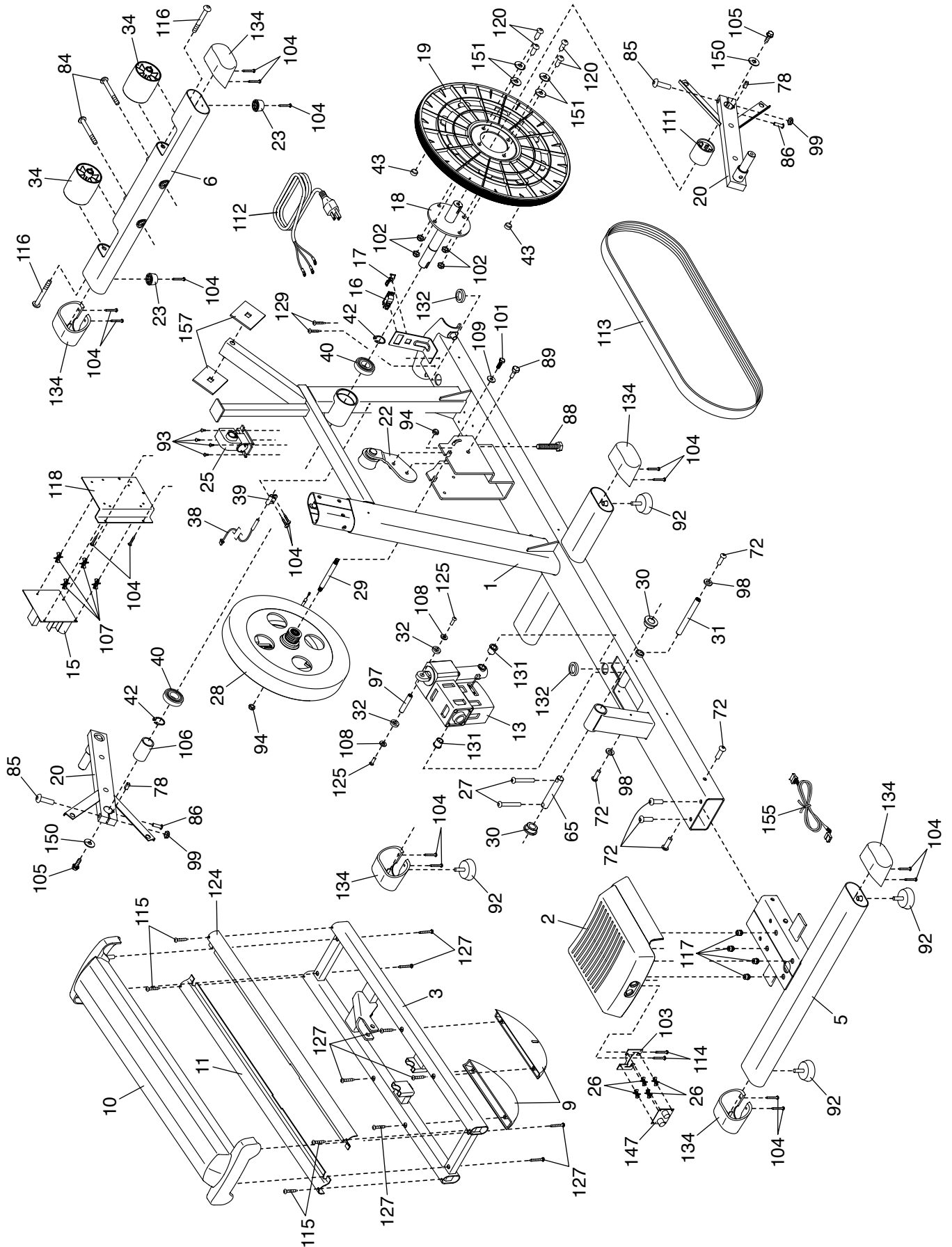

EXPLODED DRAWING B

Model No. EPEL12912.1 R1112A

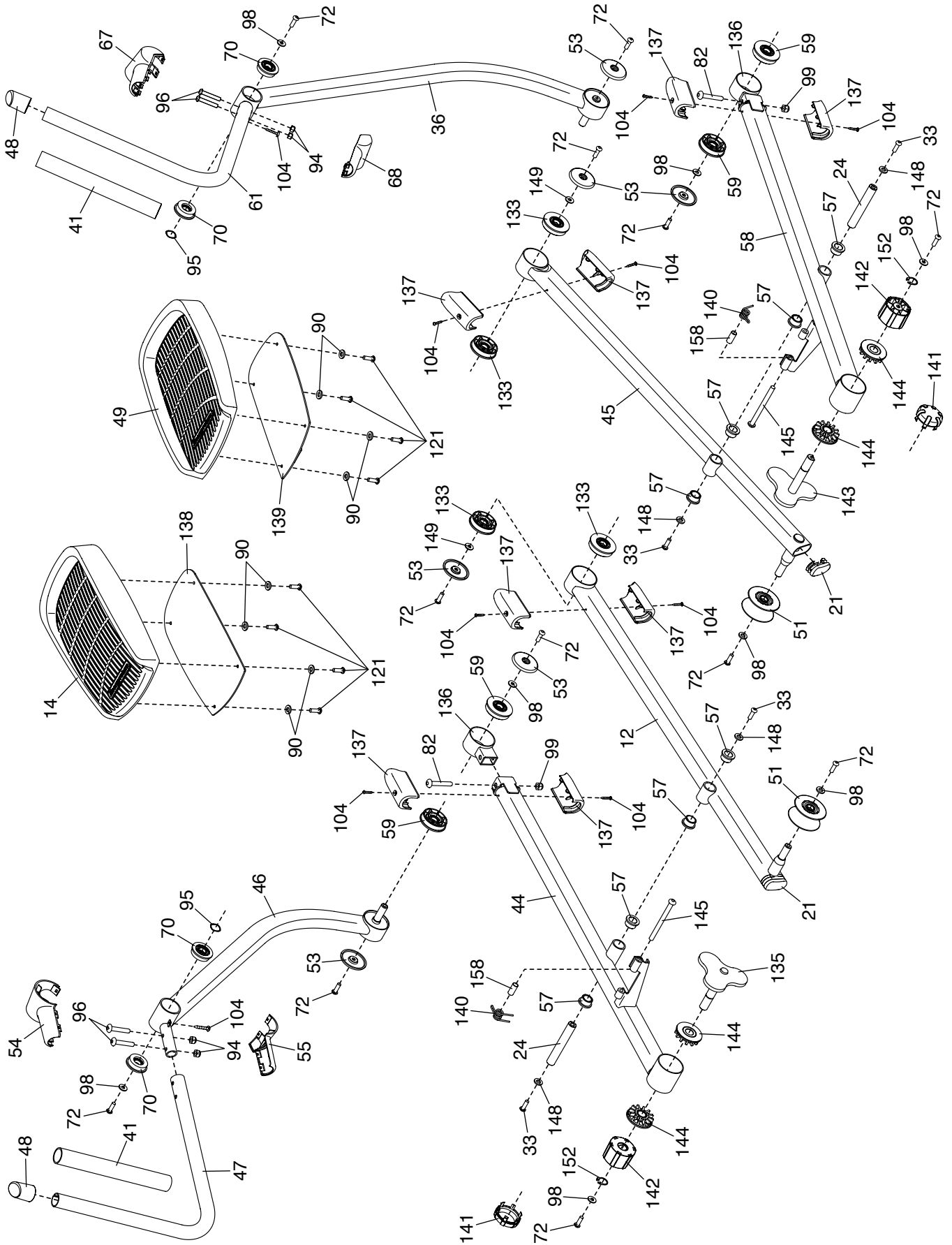

EXPLODED DRAWING C

Model No. EPEL12912.1 R1112A

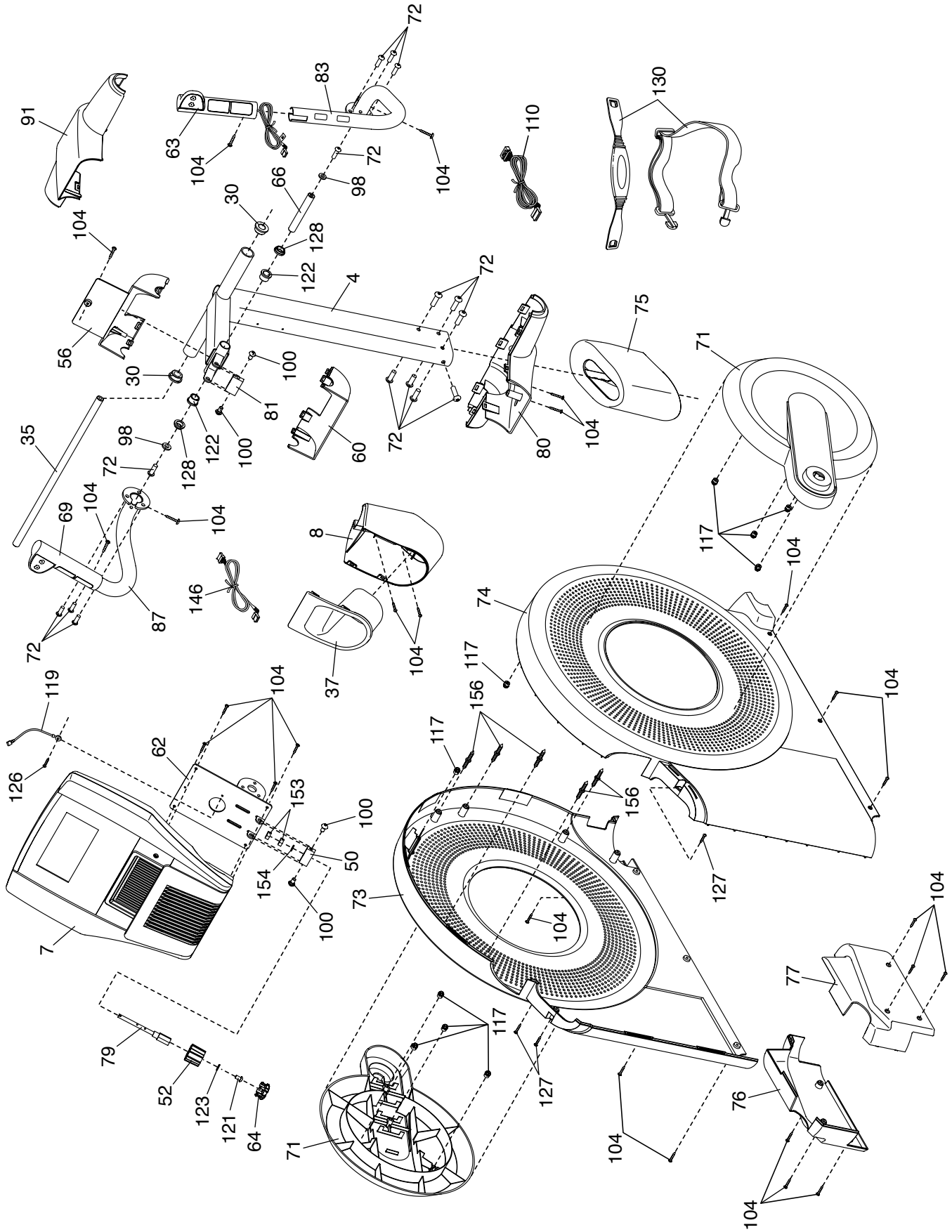

ORDERING REPLACEMENT PARTS

To order replacement parts, please see the front cover of this manual. To help us assist you, be prepared to provide the following information when contacting us:

- the model number and serial number of the product (see the front cover of this manual)
- the name of the product (see the front cover of this manual)
- the key number and description of the replacement part(s) (see the PART LIST and the EXPLODED DRAWING near the end of this manual)

LIMITED WARRANTY

IMPORTANT: You must register this product within 30 days of the purchase date to avoid added fees for service needed under warranty. Go to www.epicfit.com/registration.

ICON Health & Fitness, Inc. (ICON) warrants this product to be free from defects in workmanship and material, under normal use and service conditions. The frame and the eddy mechanism are warranted for the lifetime of the original purchaser (customer). Parts are warranted for five (5) years from the date of purchase. Labor is warranted for two (2) years from the date of purchase.

This warranty extends only to the original purchaser (customer). ICON's obligation under this warranty is limited to repairing or replacing, at ICON's option, the product through one of its authorized service centers. All repairs for which warranty claims are made must be preauthorized by ICON. If the product is shipped to a service center, freight charges to and from the service center will be the customer's responsibility. If replacement parts are shipped while the product is under warranty, the customer will be responsible for a minimal handling charge. For in-home service, the customer will be responsible for a minimal trip charge. This warranty does not extend to freight damage to the product. This warranty will automatically be voided if the product is used as a store display model, if the product is purchased or transported outside the USA, if all instructions in this manual are not followed, if the product is abused or improperly or abnormally used, or if the product is used for commercial or rental purposes. No other warranty beyond that specifically set forth above is authorized by ICON.

ICON is not responsible or liable for indirect, special, or consequential damages arising out of or in connection with the use or performance of the product; damages with respect to any economic loss, loss of property, loss of revenues or profits, loss of enjoyment or use, or costs of removal or installation; or other consequential damages of any kind. Some states do not allow the exclusion or limitation of incidental or consequential damages. Accordingly, the above limitation may not apply to the customer.

The warranty extended hereunder is in lieu of any and all other warranties, and any implied warranties of merchantability or fitness for a particular purpose are limited in their scope and duration to the terms set forth herein. Some states do not allow limitations on how long an implied warranty lasts. Accordingly, the above limitation may not apply to the customer.

This warranty provides specific legal rights; the customer may have other rights that vary from state to state.

ICON Health & Fitness, Inc., 1500 S. 1000 W., Logan, UT 84321-9813