

# User's Manual

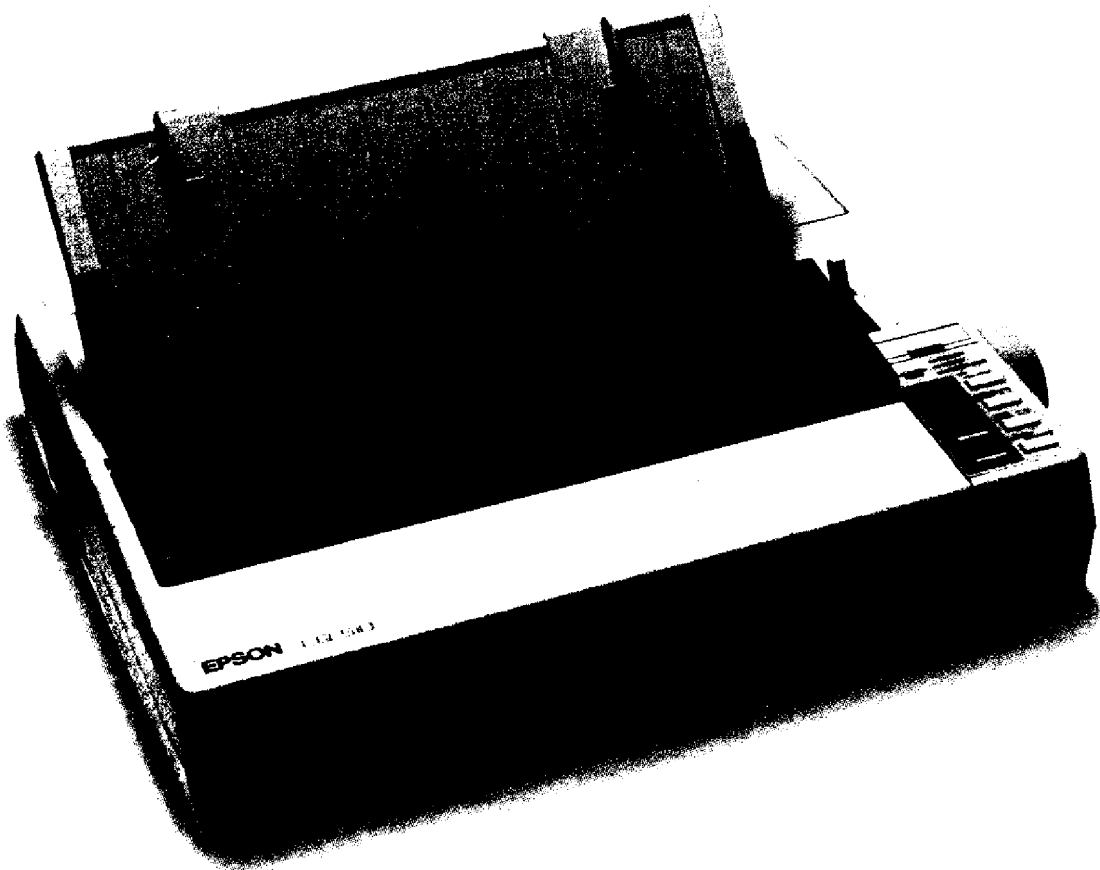

---

**EPSON®**

**EPSON®**

**LQ-510/1010**

**User's Manual**

---

## FCC COMPLIANCE STATEMENT FOR AMERICAN USERS

This equipment has been tested and found to comply with the limits for a class B digital device, pursuant to Part 15 of the FCC Rules. These limits are designed to provide reasonable protection against harmful interference in a residential installation. This equipment generates, uses and can radiate radio frequency energy and, if not installed and used in accordance with the instructions, may cause harmful interference to radio or television reception. However, there is no guarantee that interference will not occur in a particular installation. If this equipment does cause interference to radio and television reception, which can be determined by turning the equipment off and on, the user is encouraged to try to correct the interference by one or more of the following measures:

- Reorient or relocate the receiving antenna
- Increase the separation between the equipment and receiver
- Connect the equipment into an outlet on a circuit different from that to which the receiver is connected
- Consult the dealer or an experienced radio/TV technician for help.

### WARNING

The connection of a non-shielded equipment interface cable to this equipment will invalidate the FCC Certification of this device and may cause interference levels which exceed the limits established by the FCC for this equipment. It is the responsibility of the user to obtain and use a shielded equipment interface cable with this device. If this equipment has more than one interface connector, do not leave cables connected to unused interfaces.

Changes or modifications not expressly approved by Epson America, Inc., could void the user's authority to operate the equipment.

### FOR CANADIAN USERS

This digital apparatus does not exceed the Class B limits for radio noise emissions from digital apparatus as set out in the radio interference regulations of the Canadian Department of Communications.

Le present appareil numerique n'emet pas de bruits radioelectriques depassant les limites applicables aux appareils numeriques de Classe B prescrites dans le reglement sur le brouillage radioelectriques edicte par le Ministere des Communications du Canada.

All rights reserved. No part of this publication may be reproduced, stored in a retrieval system, or transmitted in any form or by any means, mechanical, photocopying, recording, or otherwise, without the prior written permission of Epson America, Inc. No patent liability is assumed with respect to the use of information contained herein. While every precaution has been taken in the preparation of this book, Epson America, Inc. assumes no responsibility for errors or omissions. Neither is any liability assumed for damages resulting from the use of information contained herein.

Epson America, Inc. shall not be liable against any damages arising from the use of any options other than those designated as Original Epson Products by Seiko Epson Corporation.

Epson and Epson ESC/P are registered trademarks of Seiko Epson Corporation.

General Notice: Other product names used herein are for identification purposes only and may be trademarks of their respective companies.

Copyright © 1990 by Epson America, Inc.  
Torrance, California

## **IMPORTANT SAFETY INSTRUCTIONS**

1. Read all of these instructions and save them for later reference.
2. Follow all warnings and instructions marked on the product.
3. Unplug this product from the wall outlet before cleaning. Do not use liquid cleaners or aerosol cleaners. Use a damp cloth for cleaning,
4. Do not use this product near water.
5. Do not place this product on an unstable cart, stand, or table. The product may fall, causing serious damage to the product.
6. Slots and openings in the cabinet and the back or bottom are provided for ventilation; to ensure reliable operation of the product and to protect it from overheating, these openings must not be blocked or covered. The openings should never be blocked by placing the product on a bed, sofa, rug, or other similar surface. This product should never be placed near or over a radiator or heat register. This product should not be placed in a built-in installation unless proper ventilation is provided.
7. This product should be operated from the type of power source indicated on the marking label. If you are not sure of the type of power available, consult your dealer or local power company.
8. This product is equipped with a 3-wire grounding-type plug, a plug having a third (grounding) pin. This plug will only fit into a grounding-type power outlet. This is a safety feature. If you are unable to insert the plug into the outlet, contact your electrician to replace your obsolete outlet. Do not defeat the purpose of the grounding-type plug.
9. Do not locate this product where the cord will be walked on.

10. If an extension cord is used with this product, make sure that the total of the ampere ratings on the products plugged into the extension cord do not exceed the extension cord ampere rating. Also, make sure that the total of all products plugged into the wall outlet does not exceed 15 amperes.
11. Never push objects of any kind into this product through cabinet slots, as they may touch dangerous voltage points or short out parts that could result in a risk of fire or electric shock. Never spill liquid of any kind on the product.
12. Except as specifically explained in the User's Manual, do not attempt to service this product yourself. Opening or removing those covers that are marked "Do Not Remove" may expose you to dangerous voltage points or other risks. Refer all servicing in those compartments to service personnel.
13. Unplug this product from the wall outlet and refer servicing to qualified service personnel under the following conditions:
  - A. When the power cord or plug is damaged or frayed.
  - B. If liquid has been spilled into the product.
  - C. If the product has been exposed to rain or water.
  - D. If the product does not operate normally when the operating instructions are followed. Adjust only those controls that are covered by the operating instructions, since improper adjustment of other controls may result in damage and will often require extensive work by a qualified technician to restore the product to normal operation.
  - E. If the product has been dropped or the cabinet has been damaged.
  - F. If the product exhibits a distinct change in performance, indicating a need for service.

# Contents

<b>Introduction</b>	<b>1</b>
<hr/>	
Features .....	1
Options.. .....	2
About This Manual .....	5
Where to Get Help. ....	6
<b>Chapter 1 Setting Up the Printer</b>	<b>1-1</b>
<hr/>	
Unpacking the Printer. ....	1-2
Choosing a Place for the Printer .....	1-5
Assembling the Printer. ....	1-7
Testing the Printer. ....	1-15
Connecting the Printer to Your Computer .....	1-22
Setting Up Your Application Software .....	1-25
<b>Chapter 2 Paper Handling</b>	<b>2-1</b>
<hr/>	
Selecting a Paper Feeding Method .....	2-2
Using Single Sheets .....	2-4
Using Continuous Paper .....	2-8
Switching Between Continuous and Single Sheets .....	2-16
Printing on Special Paper. ....	2-23
<b>Chapter 3 Using the Printer</b>	<b>3-1</b>
<hr/>	
Operating the Control Panel .....	3-2
Selecting Typestyles .....	3-6
Setting the DIP Switches. ....	3-11
Page Length .....	3-15
Skip Over Perforation .....	3-16
Adjusting the Loading Position. ....	3-17
Using Short Tear-off .....	3-19

Selecting an International Character Set .....	3-22
Choosing a Character Set .....	3-24
Using the Data Dump Mode .....	3-26
<b>Chapter 4 Software and Graphics</b>	<b>4-1</b>
<hr/>	
Enhancing Your Printing .....	4-2
Graphics .....	4-7
User-defined Characters. ....	4-17
<b>Chapter 5 Using the Printer Options</b>	<b>5-1</b>
<hr/>	
The Cut Sheet Feeder .....	5-2
The Pull Tractor .....	5-24
The Interface Boards .....	5-37
<b>Chapter 6 Maintenance</b>	<b>6-1</b>
<hr/>	
Cleaning the Printer .....	6-2
Replacing the Ribbon .....	6-4
Transporting the Printer. ....	6-10
<b>Chapter 7 Troubleshooting</b>	<b>7-1</b>
<hr/>	
Printing .....	7-2
Paper Handling .....	7-7
Options.. ....	7-10
<b>Chapter 8 Technical Specifications</b>	<b>8-1</b>
<hr/>	
Printer Specifications .....	8-2
Interface Specifications .....	8-9
<b>Option</b> Specifications .....	8-13
Initialization. ....	8-15

<b>Chapter 9 Command Summary</b>	9-1
<hr/>	
Using the Command Summary. ....	9-2
Commands in Numerical Order .....	9-5
Commands Arranged by Topic. ....	9-8
<b>Appendix</b>	A-1
<hr/>	
Proportional Width Table .....	A-2
Character Sets. ....	A-6
<b>Glossary</b>	
<hr/>	
Index	
<hr/>	



# Introduction

The Epson® LQ-510 and LQ-1010 are advanced 24-pin dot matrix printers combining compact design and high performance with a wide range of features.

## Features

In addition to the high-quality printing and ease of operation you have come to expect from Epson printers, the LQ-510 and LQ-1010 offer the following features:

- Easy paper handling, featuring automatic single-sheet loading.
- Compatibility with the Epson ESC/P® commands used by the LQ-500, LQ-800, LQ-850, LQ-950, LQ-1000, LQ-1050, LQ-1500, LQ-2500, and LQ-2550.
- Fast draft mode printing of up to 192 characters per second at 12 cpi (characters per inch).
- An improved control panel design that allows direct selection of character fonts, as well as a choice of normal or condensed printing.
- The SmartPark™ paper handling system, which allows use of single sheets of paper without removing the continuous paper, eliminates paper waste with short tear-off, and allows easy and accurate paper alignment.
- Nine built-in Letter Quality fonts for producing high-quality documents:
  - Epson Roman, Epson San Serif, Epson Courier, Epson Prestige, OCR-B, OCR-A, Epson Script, Epson Orator, Epson Orator-S
- A 360 x 360 dot per inch graphics mode.

- A micro-adjustment feature that allows you to feed the paper forward or backward to finely adjust the loading and short tear-off positions.
- Fifteen international character sets, an italic character set, and five graphics character sets.
- The ability to handle a wide range of paper types, including envelopes and labels.

The LQ-510 and LQ-1010 are basically the same printer except for the width of their carriages. The LQ-510 has a standard width carriage that accommodates paper up to a width of 10 inches. The LQ-1010 has a wide carriage that accommodates paper up to a width of 14 inches.

Throughout this manual, the LQ-510 is referred to as the standard width printer and the LQ-1010 is referred to as the wide carriage printer.

## **Options**

A variety of printer options is available for use with your printer. For detailed information on installing and using these options, see Chapter 5.

To locate or purchase options or supplies, call Epson Accessories, Inc. at 1-800-873-7766.

- **Film Ribbon Cartridge (#7768/#7770)**

An optional film ribbon cartridge provides you with even higher quality printing than the standard fabric ribbon.

- **Single-bin Cut Sheet Feeder (C806122/C806242)**

The cut sheet feeder makes it possible to handle single-sheet paper more easily and more efficiently. Up to 150 sheets of standard bond paper can be automatically fed into the printer without reloading.

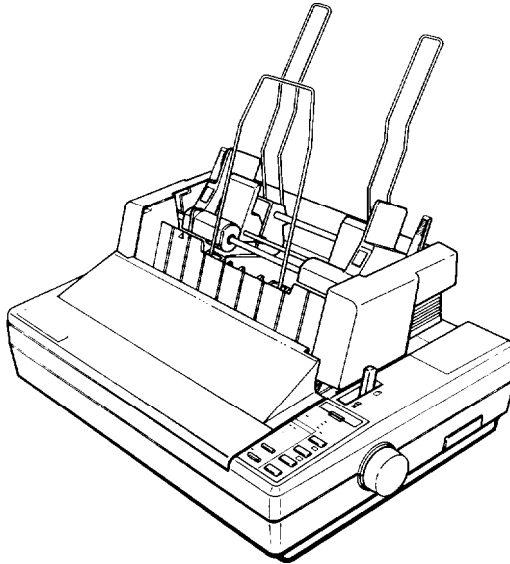

- **Pull Tractor Unit (C800062/C800142)**

This option improves the performance of continuous paper handling. It is especially useful with continuous multi-part forms.

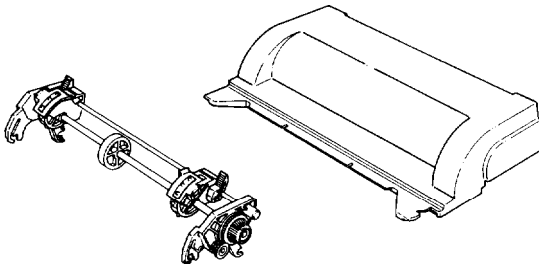

## • **Interface Boards**

Optional interface boards are available to supplement the printer's built-in parallel interface. Guidelines for choosing the right interface and instructions on installing the boards are given in Chapter 5.

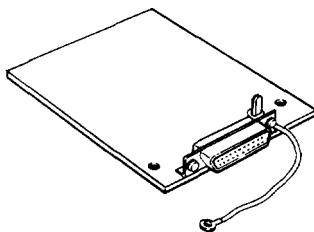

## **About This Manual**

This user's manual provides fully illustrated, step-by-step instructions on setting up and operating your printer.

### **Finding your way around**

- Chapter 1 contains information on unpacking, setting up, testing, and connecting the printer. Be sure to read and follow these instructions first. Inside the back cover of this manual are illustrations of the printer in which all of the major parts are identified.
- Chapters 2 and 3 cover paper handling and general printer operation. This important information is necessary for the day-to-day operation of your printer.

- Chapter 4 shows you how to get the most from your printer. It includes advice on the use of software commands, graphics, and creating your own user-defined characters. See Chapter 9 for a useful summary of printer commands.
- If the printer does not operate properly or the printed results are not what you expect, see Chapter 7 for troubleshooting instructions.
- Other chapters and the appendix contain information on printer options, general maintenance, and specifications. You will also find a glossary of printer terms.
- At the back of this manual is a handy Quick Reference card that contains the information you are most likely to need.

**Note:** The majority of the illustrations in this manual show the standard width printer. Whenever necessary, an illustration is included to show the wide carriage printer.

## Warnings, Cautions, and Notes



**WARNINGS** must be followed to avoid bodily injury.



**CAUTIONS** must be observed to avoid damage to your printer.

**Notes** contain important information and useful tips on the operation of your printer.

## **Where to Get Help**

A network of authorized Epson dealers and Customer Care Centers throughout the United States offers customer support and service for Epson products. Epson America provides product information and support to its dealers and Customer Care Centers.

Therefore, we ask that you contact the business where you purchased your Epson product to request assistance. If the people there do not have the answer to your question, they can obtain it through our dealer support program.

Epson is confident that this policy will provide you with the assistance you need. Call the Epson Consumer Information Center at 1-213-782-2600 for the following:

- The location of the nearest Epson dealer
- The location of the nearest Customer Care Center.

To locate or purchase accessories or supplies, contact your Epson dealer.

# Chapter 1

## Setting Up the Printer

Unpacking the Printer. ....	1-2
Checking the Parts. ....	1-2
Removing the Protective Materials. ....	1-3
Choosing a Place for the Printer. ....	1-5
Assembling the Printer. ....	1-7
Installing the Platen Knob. ....	1-7
Installing the Ribbon Cartridge. ....	1-8
Attaching the Paper Guide. ....	1-13
Testing the Printer. ....	1-15
Plugging in the Printer. ....	1-15
Running the Self Test. ....	1-15
Connecting the Printer to Your Computer. ....	1-22
The Parallel Interface. ....	1-22
Setting Up Your Application Software. ....	1-25



---

# Unpacking the Printer

This section describes how to unpack your printer.

## Checking the Parts

When you unpack the printer, make sure that you have all the parts shown below and that none have been damaged.

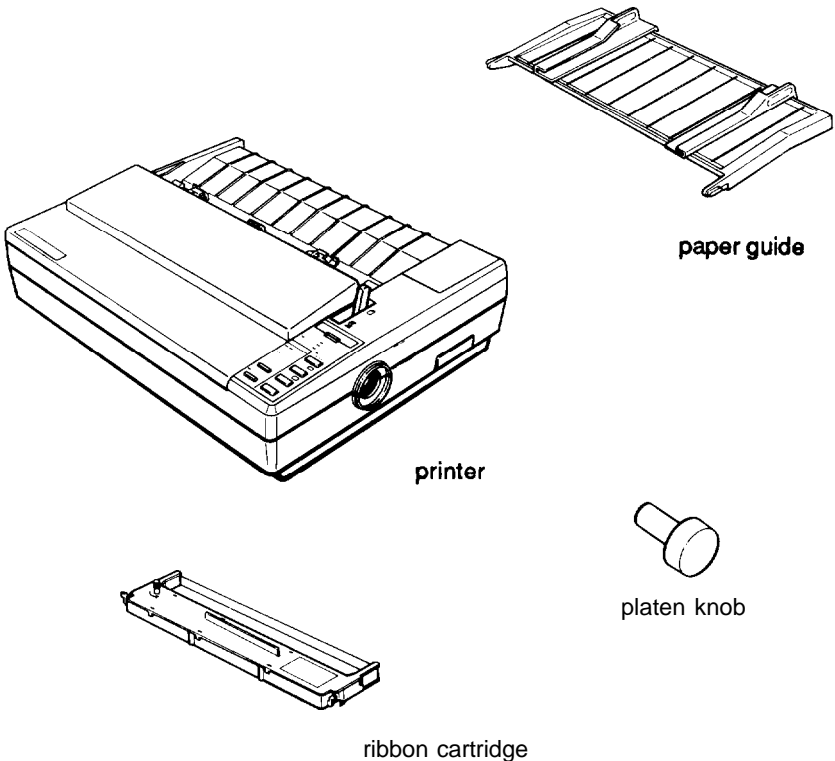

After removing the parts, save the packaging materials in case you ever need to transport your printer.

## 1-2 Setting Up the Printer



## Removing the Protective Materials

The printer is protected during shipping by pieces of white packing material. Also, the wide carriage printer is protected by a locking clip, which must be removed before you turn on the printer.



**CAUTION:** Before turning on the wide carriage printer, be absolutely sure you have removed the locking clip. Turning on the printer while the clip is attached may seriously damage the mechanism.

Follow these steps to remove the protective materials.

1. Remove the printer cover.

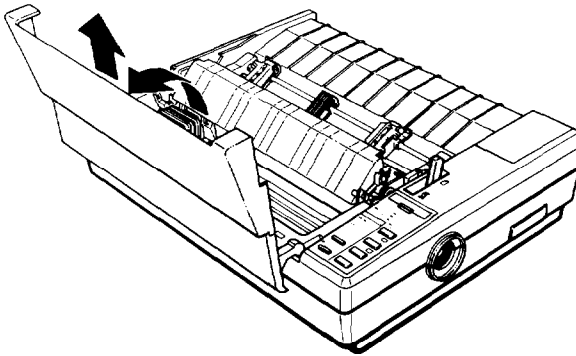

2. Remove the pieces of white packing material. At this point, the standard width printer is completely unpacked.

# Unpacking the printer

3. To remove the locking clip on the wide carriage printer, lift and remove the paper tension unit.

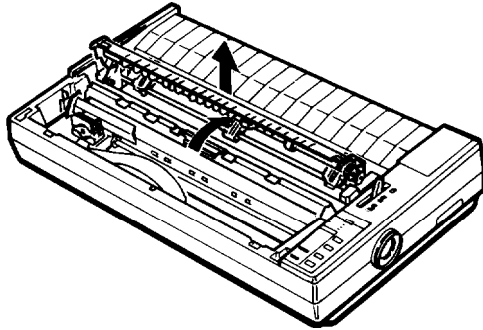

4. Remove the locking clip.

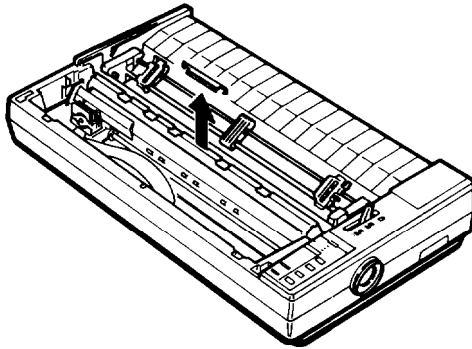

**Note:** Store the clip with the other packing material in case you ever need to transport your printer.

## **Choosing a Place for the Printer**

There are several important things to consider when selecting a place to set up your printer. Keep the following in mind:

- Place the printer on a flat, hard, stable surface. A soft surface, such as a padded counter or carpeted area, will block the ventilation slots and may cause overheating.
- Place the printer close enough to the computer for the printer cable to reach.
- Leave adequate room around the printer to allow for easy printer operation and maintenance, and for unrestricted flow of air around the printer.
- Use a grounded outlet; do not use an adapter plug.
- Avoid locations that are subject to direct sunlight, excessive heat, moisture, or dust.
- Avoid electrical outlets controlled by wall switches or automatic timers. Accidental interruption of power can wipe out information in both your computer's and printer's memory.
- Avoid using outlets that share a circuit with large motors or electrical appliances; this could cause fluctuations in line voltage.
- Keep the entire computer system away from potential sources of electromagnetic interference such as loudspeakers or the base units of cordless telephones.

The illustration below shows a good printer location.

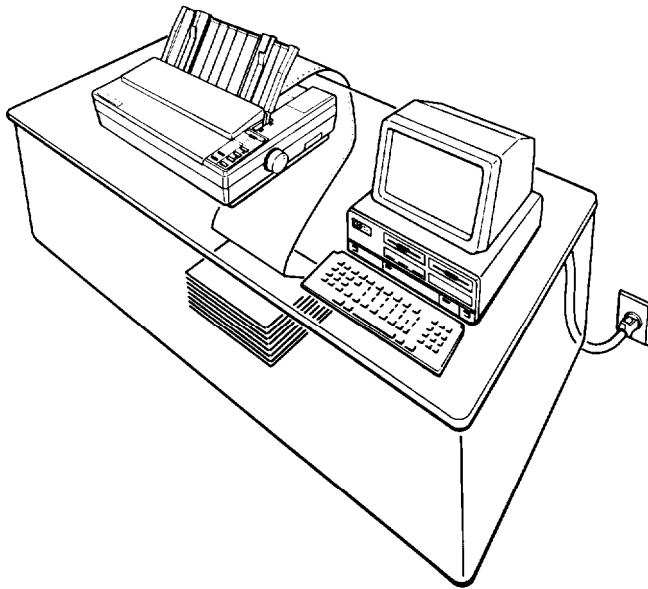

Note: Before using a printer stand, read these requirements and suggestions.

- The stand should be able to support at least twice the weight of the printer.
- Never use a stand that supports the printer at an angle of more than 15 degrees from horizontal.
- With a cut sheet feeder, your printer must be kept level.
- If your paper supply is positioned below the printer stand, make sure there is enough clearance to keep the paper from catching on the underside of the stand. Also, make sure the distance between the stand supports is wide enough for the paper you are using.
- Position your printer's cables so that they do not interfere with paper feeding. If possible, secure the cables to the printer stand.

# Assembling the Printer

After you've decided on the best place to set up your printer, the next step is to install the platen knob.

## Installing the Platen Knob

The platen knob is used to feed the paper manually in the event of a paper jam or other paper feeding problem. The platen knob is packed in an indentation in the printer's white foam packing material.

1. Insert the knob into the hole on the printer's side and rotate it slowly until it slips onto the shaft.

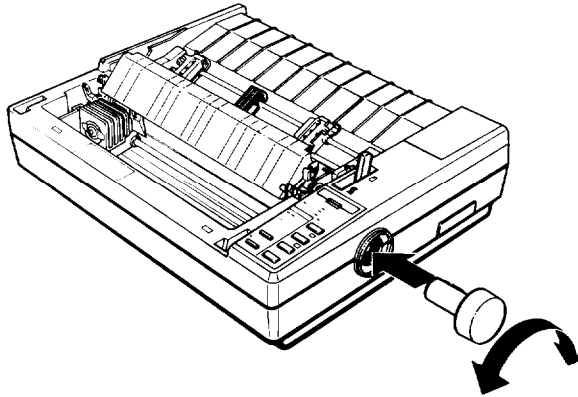

2. Push firmly on the platen knob until it fits against the printer case.

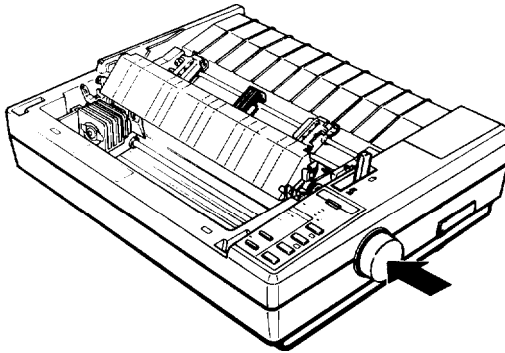

**CAUTION:** Do not use the platen knob to adjust the position of the paper. This interferes with the automatic paper loading system and may cause a paper jam.

### **Installing the Ribbon Cartridge**

Your printer's ribbon cartridge is designed for easy installation and removal. Before installing the ribbon cartridge, make sure the printer is turned off.

Install the ribbon cartridge as follows.

1. Slide the print head to the middle of the printer.

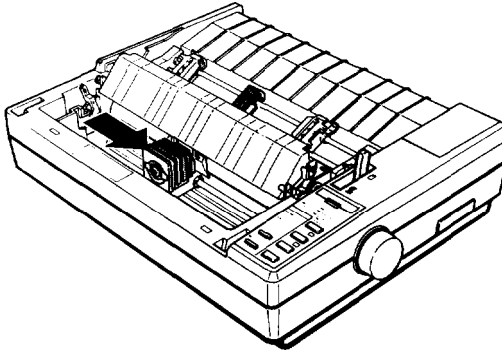

**CAUTION:** Never move the print head while the printer is turned on because this can damage the printer. Also, if you have been using the printer, the print head may be hot; let it cool for a few minutes before touching it.

2. Turn the ribbon-tightening knob in the direction of the arrow. This removes slack in the ribbon and makes it easier to install.

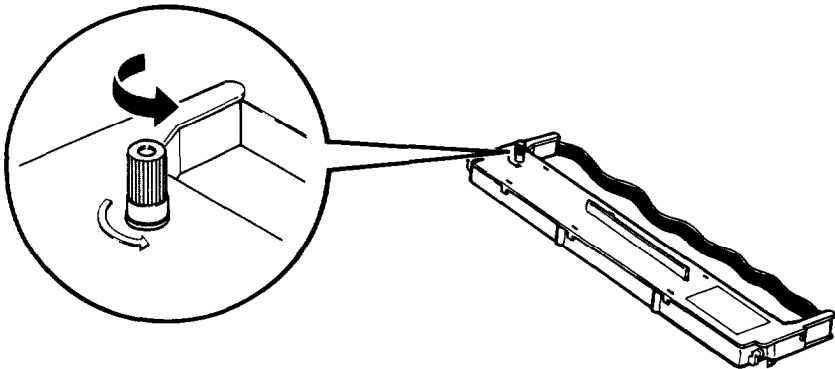

3. On the standard width printer, open the paper tension unit cover. (On the wide carriage printer, you already removed the paper tension unit when you removed the locking clip.)

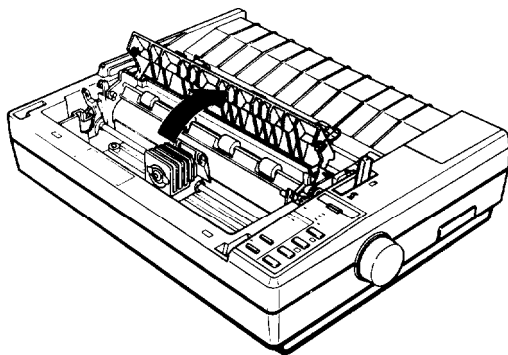

4. Hold the ribbon cartridge by its handle and push it firmly down into position, making sure the plastic hooks fit into the slots.

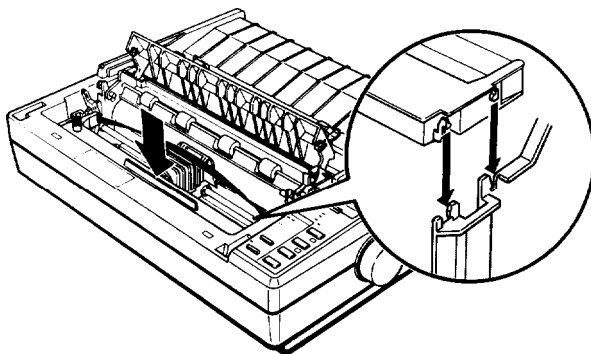

**Note:** Press lightly on both ends of the cartridge to make sure the plastic hooks are properly seated.



5. Use a pointed object, such as a ball point pen, to guide the ribbon between the print head and ribbon guide while you turn the ribbon-tightening knob to help feed the ribbon into place.

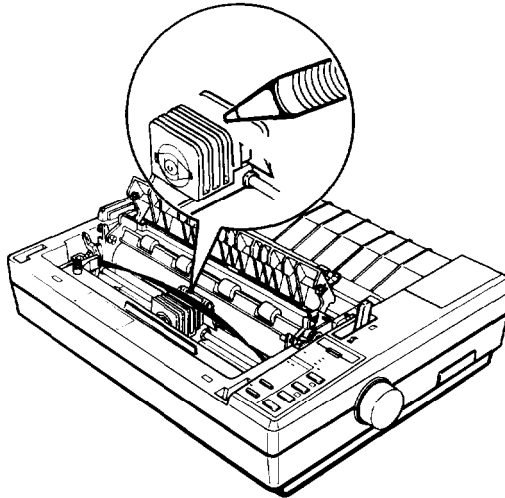

6. Slide the print head from side to side to make sure it moves smoothly. Also check that the ribbon is not twisted or creased.

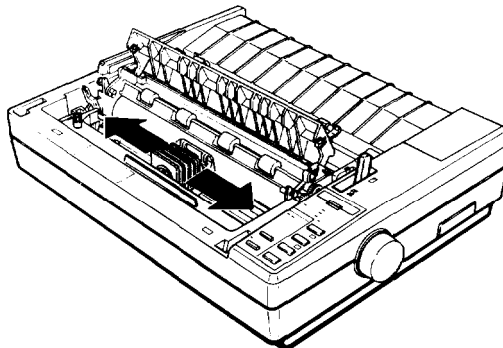

## Assembling the Printer

7. On the standard width printer, close the paper tension unit cover.

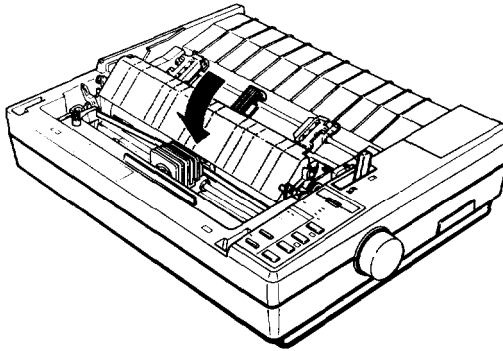

The standard width printer is now complete.

8. On the wide carriage printer, fit the rear notches of the paper tension unit over the pins of the printer; then lower the unit.

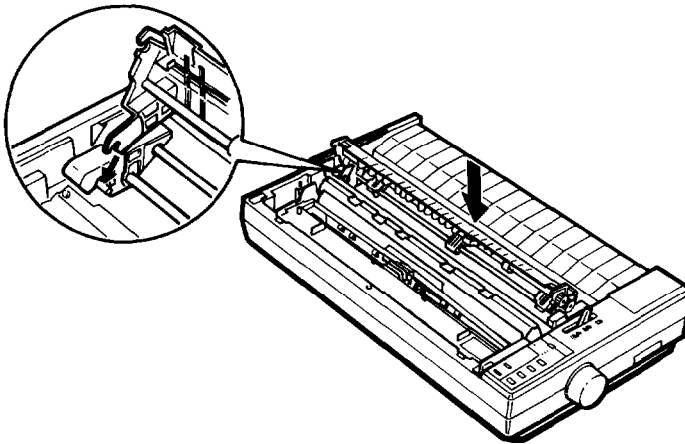

9. Press down on both sides of the paper tension unit to lock it in place.

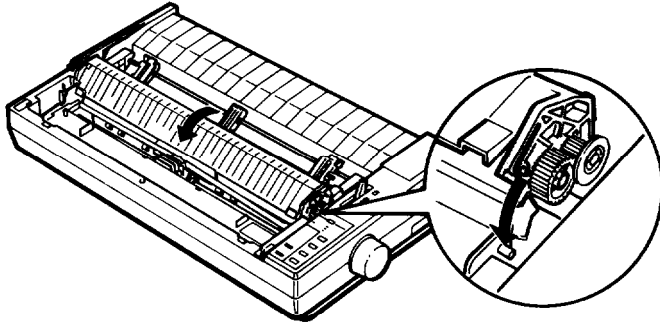

## Attaching the Paper Guide

When you use single sheets, the paper guide helps to feed the paper smoothly and efficiently into the printer. Attach the paper guide using the following procedure.

1. Place the paper guide on the printer.

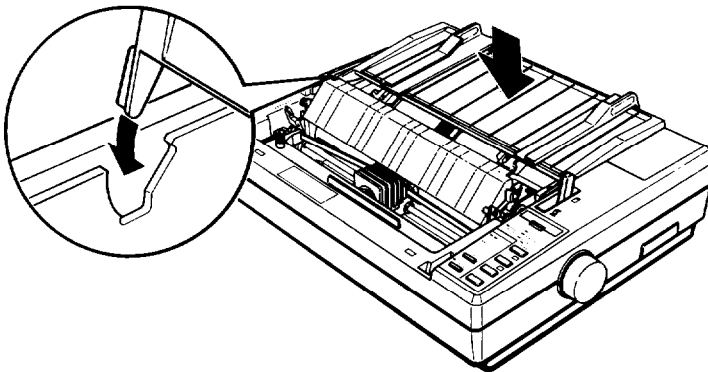

2. Raise the paper guide until it locks into place.

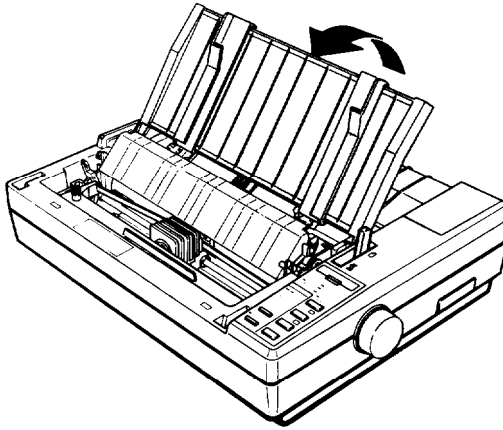

Note: To lower the paper guide, lift up slightly to release it from its locked position; then gently lower it down onto the printer.

3. Attach the printer cover by fitting the hooks on the cover into the notches at the front of the printer and tilting the cover back into place.

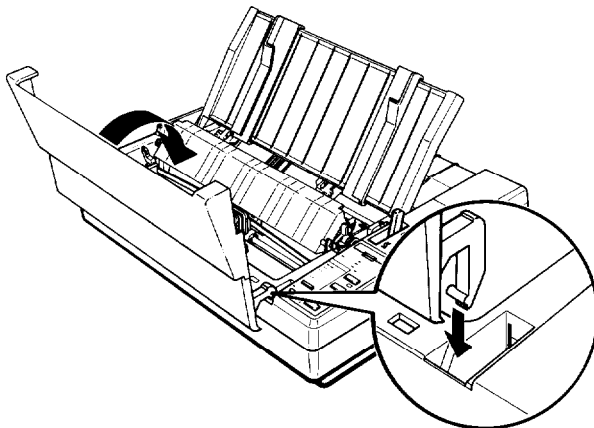

## Testing the Printer

Now that your printer is fully assembled, you can use its built-in self test function to see that the printer is working correctly before you connect it to a computer. You should perform this test to make sure that your printer was not damaged during shipping and that the ribbon is correctly installed.

Before running the self test, you need to connect the printer to an electrical outlet and load a sheet of paper.

### Plugging in the Printer

1. Make sure that the printer is turned off.
2. Plug the power cable into a properly grounded electrical outlet.

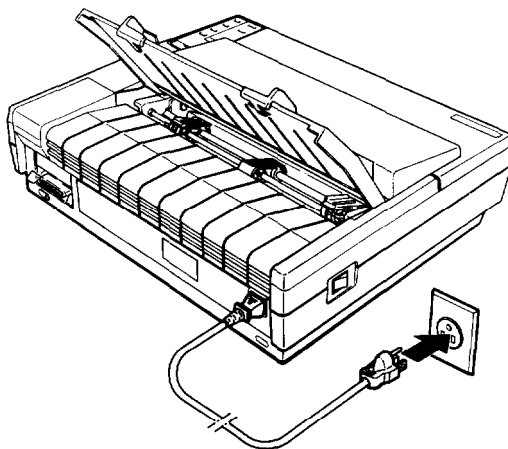

### Running the Self Test

The self test can be run in the draft or Letter Quality mode, depending on which button you hold down as you turn on the printer.

The self test is 8 inches wide on the standard width printer and 14 inches wide on the wide carriage printer.

**CAUTION:** Never run the self test using paper that is narrower than 8¼ inches (210 mm) on the standard width printer or 14 inches (360 mm) on the wide carriage printer. This prevents the print head from printing directly onto the platen, which can damage the print head.

Although the self test can be run with continuous paper, use a single sheet of paper now because single sheet loading is easier.

1. Make sure the printer is turned off.
2. Push the paper release lever back to the single sheet position.

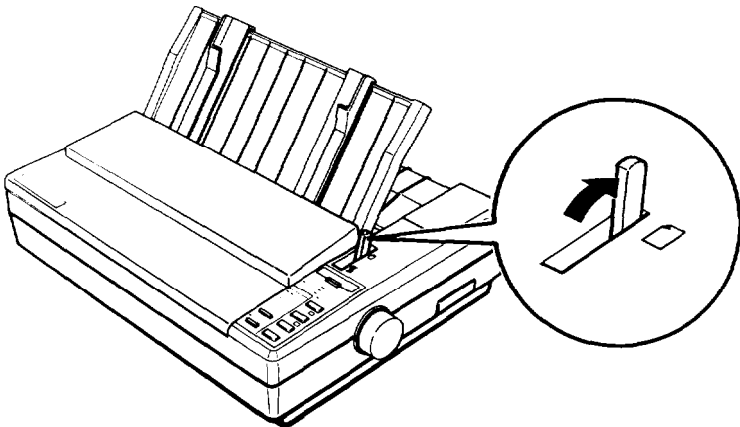

3. While holding down the LINE FEED button (draft mode) or FORM FEED button (Letter Quality mode), turn on the printer. The printer beeps several times and POWER and PAPER OUT lights come on.
4. Move the left edge guide so that it locks in place next to the guide mark.

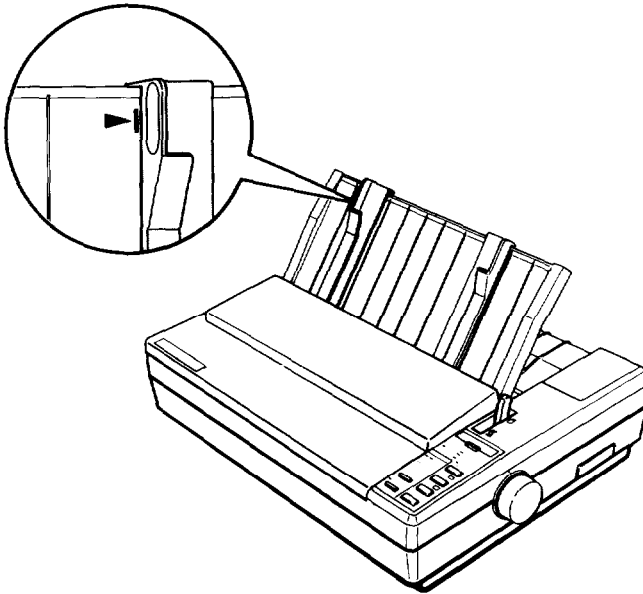

5. Adjust the right edge guide to match the width of your paper.

- Next, slide a sheet of paper down between the edge guides until it meets resistance. After about two seconds, the printer loads the paper automatically and then starts the self test.

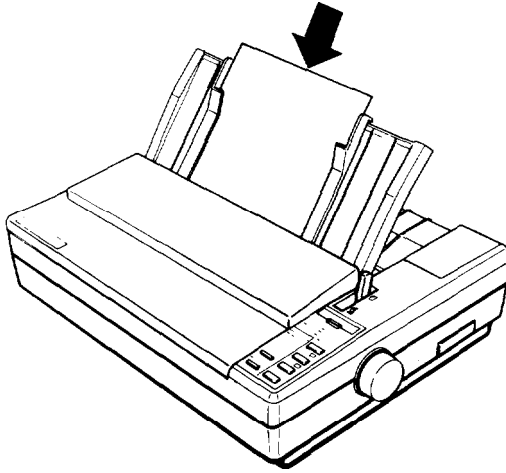

**Note:** If the platen turns without loading the paper, press the ON LINE button to take the printer off line. Then remove the paper and reinsert it more firmly.

A list of DIP switch settings is printed first, followed by a series of characters. The self test continues until the paper runs out or until you press the ON LINE button.



7. When you wish to stop the test, press the ON LINE button.
8. If the paper is still loaded, press the LOAD/EJECT button or LINE FEED button to eject it. Then turn off the printer.

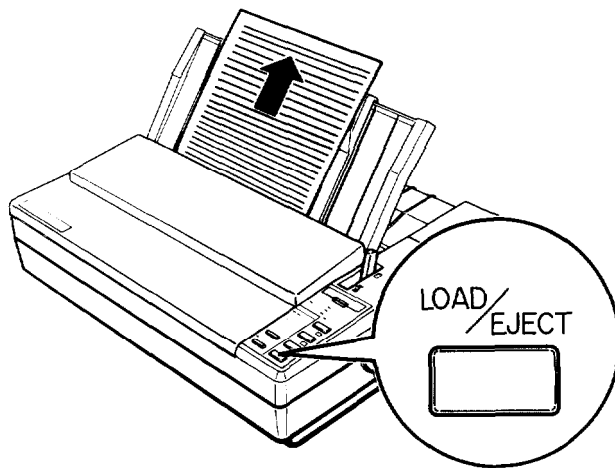

**CAUTION** After turning the power off, always wait at least five seconds before turning it back on. Turning the power on and off rapidly can damage the printer.

Here is part of a typical self test printed in Letter Quality mode.

Country/Graphic	SW1-1	1-2	1-3	Tear off
U.S.A/United States	on	on	on	Invalid
France/Multilingual	on	on	off	Valid
Germany/Portugal	on	off	on	1" Skip
U. K. /Canada-French	on	off	off	Invalid
Denmark/Norway	off	on	on	Valid
Sweden	off	on	off	Auto LF
Italy	off	off	on	Invalid
Spain	off	off	off	Valid
Page length	SW1-4	1-5		Receive I
11"	off	off		1kbytes
1.2"	on	off		8kbytes
8.5"	off	on		Graphics
A4	on	on		Uni-d
Condensed	SW1-6			Bi-d
	off			Pitch

."#\$%&'()*+,-./0123456789:;<=>?@ABCDEFGHIJKL
"#\$%&'()*+,-./0123456789:;<=>?@ABCDEFGHIJKL
#\$%&'()*+,-./0123456789:;<=>?@ABCDEFGHIJKL
\$%&'()*+,-./0123456789:;<=>?@ABCDEFGHIJKLM
%&'()*+,-./0123456789:;<=>?@ABCDEFGHIJKLMNO
&'()*+,-./0123456789:;<=>?@ABCDEFGHIJKLMNO
'()*+,-./0123456789:;<=>?@ABCDEFGHIJKLMNOP
()*+,-./0123456789:;<=>?@ABCDEFGHIJKLMNOPQ
Prestige 10
()*+,-./0123456789:;<=>?@ABCDEFGHIJKLMNOPQR

Note: When using the optional cut sheet feeder, the first page of the self test printout is slightly different. For details, see The Cut Sheet Feeder in Chapter 5.

If the self test does not print properly, check the control panel and the print head area. Make sure that all packing material and shipping restraints have been removed from inside the printer. See Chapter 7, Troubleshooting, for other possible causes and solutions.

If the printer still does not print the self test correctly, contact your dealer or call the Consumer Information number listed in Where to Get Help.

# Connecting the Printer to Your Computer

If the self test printed correctly, you are now ready to connect the printer to your computer.

If your computer has a parallel interface and you have a suitable shielded cable, you should be able to connect your printer immediately. The steps below describe how to connect the parallel interface cable.

If your computer requires another type of interface, you need to install an optional interface board. See Interface Boards in Chapter 5.

If you are not sure which type of interface cable is required, see your computer manual.

## The Parallel Interface

Connect the parallel interface cable as described below:

1. Make sure that both your printer and computer are turned off.
2. Plug the cable connector securely into the printer.

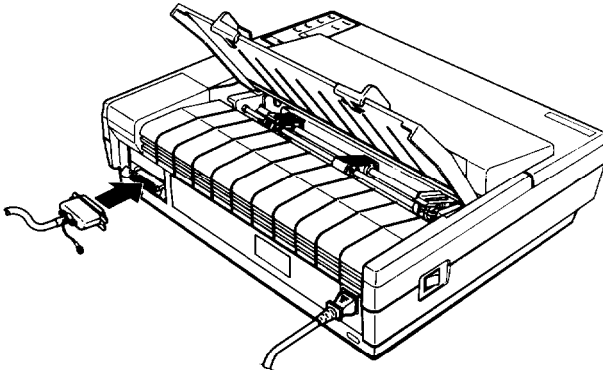

3. Squeeze the wire clips together until they lock in place on either side of the connector.

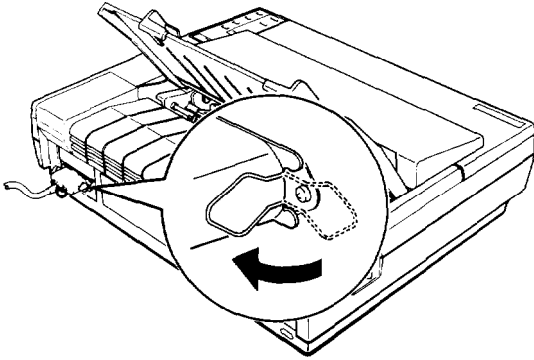

4. If your cable has a ground wire, connect it to the ground screw beneath the interface connector.

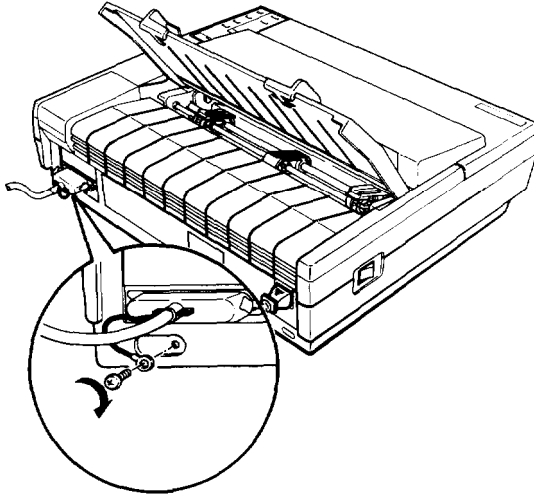

5. Plug the other end of the cable into the computer. If there is a ground wire at the computer end of the cable, attach it to the ground connector at the back of the computer.

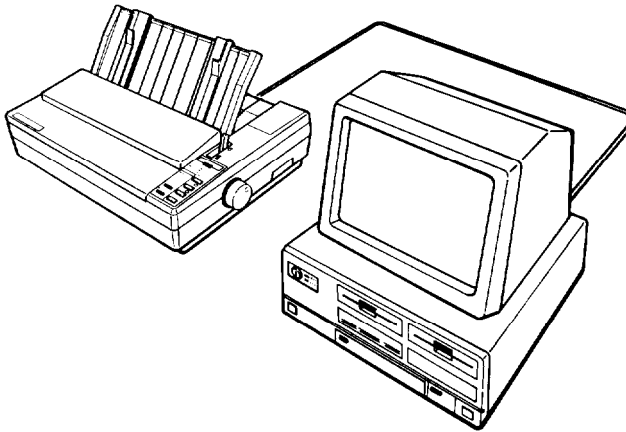

---

## **Setting Up Your Application Software**

Now that you have set up and tested the printer, you should make sure that it works with your application programs.

Most application programs let you specify the type of printer you are using so that the program can take full advantage of the printer's features. Many of these programs provide an installation or setup menu that presents a list of printers to choose from.

If your application program has a printer selection menu, use the instructions below.

### **Choosing From a Menu**

Because the family of Epson printers shares a great many commands, you can use an application program even if it does not list your printer on its selection menu. If the printer is not listed, choose one of the following printers. They are listed in order of preference.

LQ-2550

LQ-2500

LQ-850 (LQ-1050)

LQ-500

LQ-800 (LQ-1000)

LQ-1500

If none of the above printers is listed, select the first one available on the following list: LQ, EX, FX, LX, RX, MX, Epson printer, Standard printer, Draft printer.

To use all of the features of the printer, however, it is best to use a program with your printer on its menu. If an application program does not list the printer, contact the software manufacturer to see if an update is available that supports your model.

## **Chapter 2**

# **Paper Handling**

Selecting a Paper Feeding Method .....	2-2
Using Single Sheets .....	2-4
Loading Paper .....	2-4
Reloading During Printing .....	2-7
Using Continuous Paper .....	2-8
Positioning Your Continuous Paper Supply. ....	2-8
Loading Continuous Paper .....	2-8
Switching Between Continuous and Single Sheets .....	2-16
Switching to Single Sheets .....	2-16
Switching Back to Continuous Paper. ....	2-19
Printing on Special Paper. ....	2-23
The Paper Thickness Lever .....	2-23
Multi-part Forms .....	2-26
Labels .....	2-27
Envelopes .....	2-28



## Selecting a Paper Feeding Method

The paper release lever on the standard width printer has two positions and on the wide carriage printer has three positions for use with the various methods of paper feeding. Make sure the paper release lever is set to match the desired paper feeding method.

*Standard width printer*

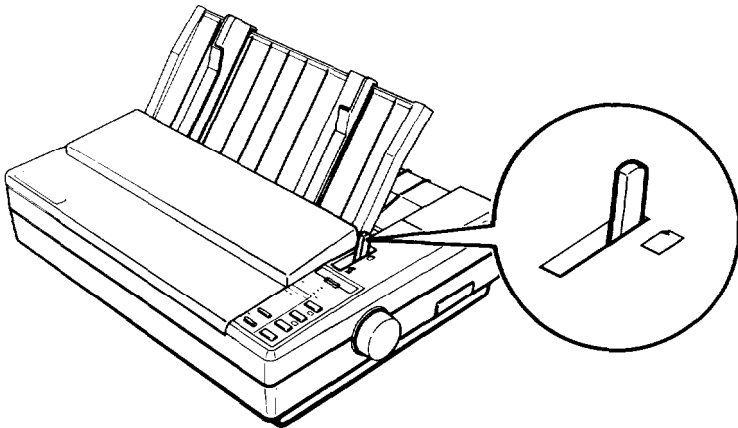

*Wide carriage printer*

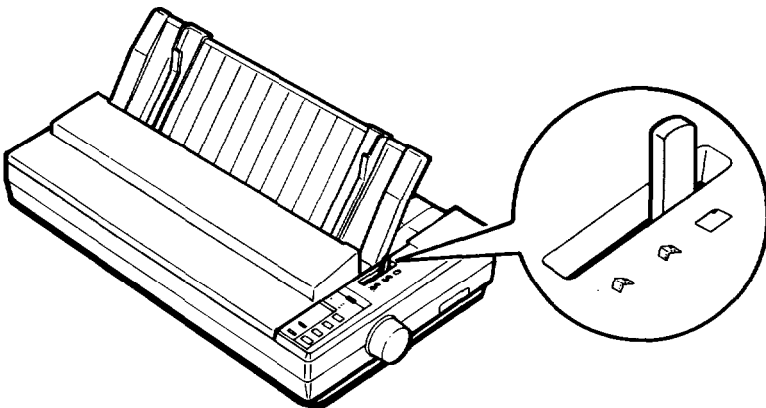

The lever positions are marked by icons.



Single sheet position: When you load single sheets from either the paper guide or from the optional cut sheet feeder, the lever should be all the way back.



Continuous feed position: When you load continuous paper with the built-in push tractor, the lever should be all the way forward on the standard width printer and in the middle on the wide carriage printer.



Pull tractor position-wide carriage printer only: When you load continuous paper with the optional pull tractor, the lever should be all the way forward on the wide carriage printer. Even when you use the built-in push tractor at the same time, you must set the lever to this position. Only select this position if you are using the optional pull tractor.

**Note:** On the standard width printer, the paper release lever is in the forward position for continuous paper whether the paper is loaded from the built-in push tractor or the optional pull tractor.

## Using Single Sheets

The standard width printer can accommodate single sheets with a width of 7.2 inches (182 mm) to 10 inches (254 mm). The wide carriage printer can accommodate single sheets with a width of 7.2 inches (182 mm) to 14.3 inches (364 mm).

If you do most of your printing on single sheets, you may find it more convenient to install the optional cut sheet feeder. This option automatically inserts a new sheet and can hold up to 150 pages. For more details, see Chapter 5.

## Loading Paper

1. Push the paper release lever back to the single sheet position.

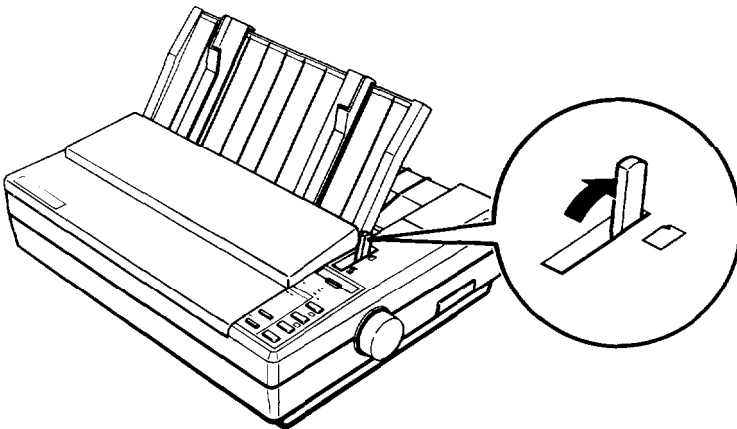

2. Turn on the printer. (The green POWER light should come on.)

**Note:** Do not insert paper before turning on the printer.

3. Move the left edge guide so that it locks in place next to the guide mark. (You may want to change this position later, depending on the margin settings of your application program.)

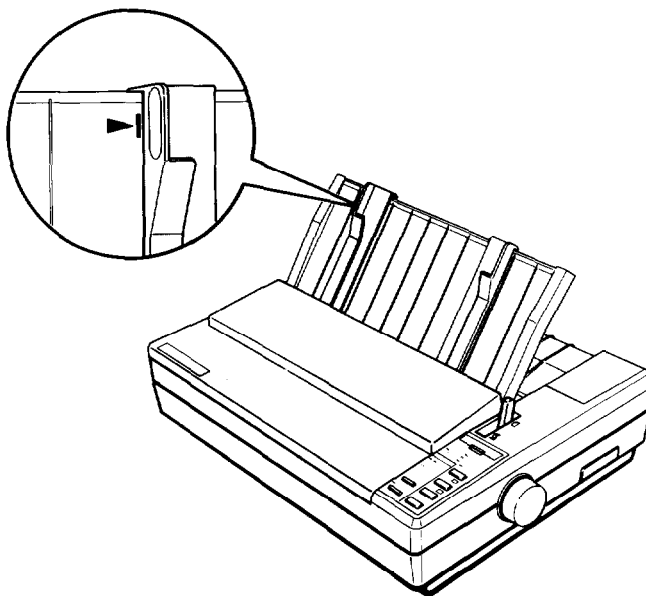

4. Adjust the right edge guide to match the width of your paper.

5. Slide the paper down between the edge guides until it meets resistance. After about two seconds, the printer loads the paper automatically and is set ON LINE so that it can accept data from your computer.

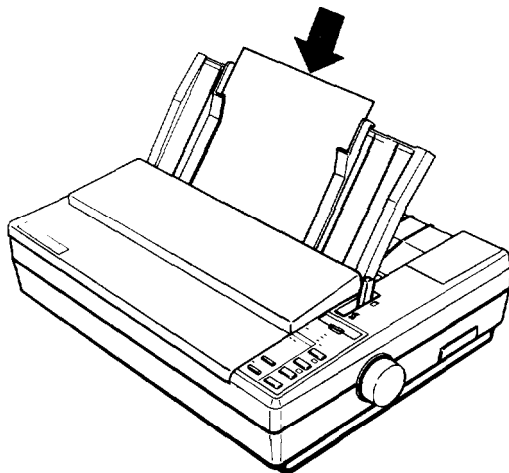

**CAUTION:** Never advance the paper using the platen knob while the printer is turned on. If the platen turns without loading the paper, press the ON LINE button to set the printer off line. Then remove the paper and reinsert it more firmly.

You are now ready to begin printing.

## **Reloading During Printing**

When you print a document of more than one page using single sheets of paper, the printer stops printing when it reaches the bottom of the page. When this happens, the ON LINE light either goes off automatically or remains on, depending on your application program software. If the ON LINE light remains on, the first thing you should do is press the ON LINE button to take the printer off line.

Once the ON Line light is off, remove the sheet that has just been printed (if necessary, press the LOAD/EJECT button to eject the page) and load a new sheet. Press the ON LINE button to start printing the next page and follow any additional prompts from your software.

## Using Continuous Paper

The push tractor built into your printer is remarkably easy to load and operate. Its low-profile design takes up little space and can handle paper up to 10 inches (254 mm) wide on the standard width printer and up to 16 inches (406 mm) wide on the wide carriage printer.

### Positioning Your Continuous Paper Supply

An important consideration for achieving smooth and trouble-free paper feeding is the position of your paper supply.

Three ways of positioning your printer and continuous paper supply are shown below.

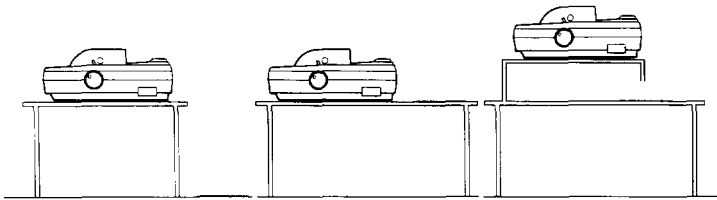

Be sure to align the paper supply with the paper loaded in the tractor so that the paper feeds smoothly into the printer.

### Loading Continuous Paper

1. Be sure that the printer is turned off, then remove the paper guide.

2. Set the paper release lever to the continuous paper position. On the standard width printer, this is the forward position.

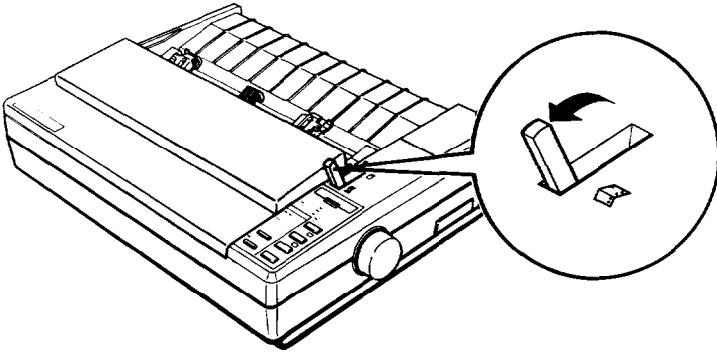

On the wide carriage printer, this is the center position.

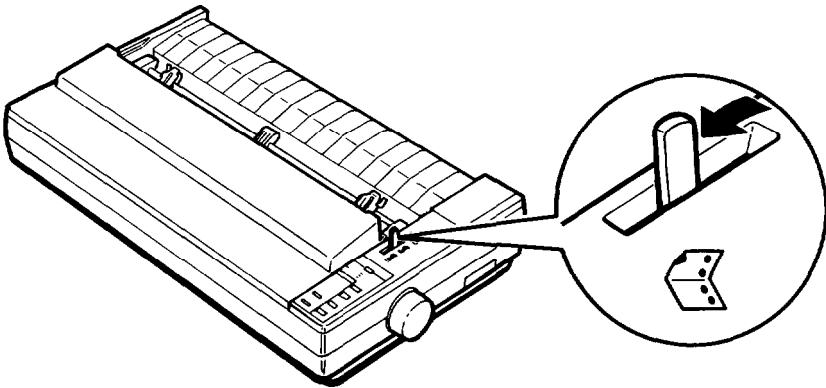



3. Release the sprocket units by pulling the sprocket lock levers forward as shown below.

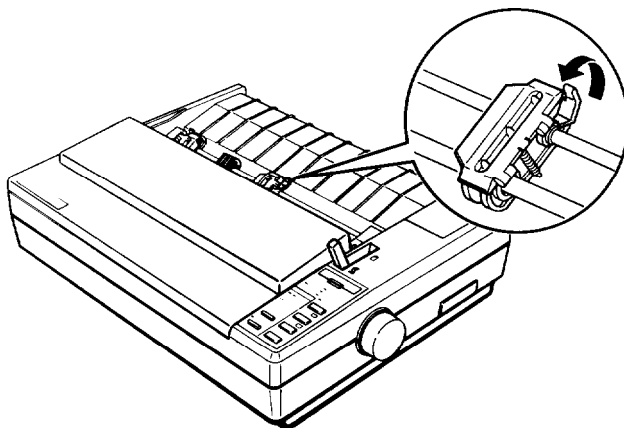

4. Slide the left sprocket unit until it is one-half inch from the farthest left position. Press the lever back to lock it in place.

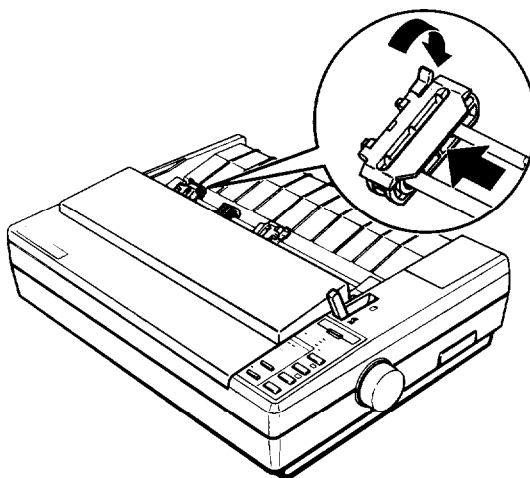

5. Slide the right sprocket unit so that it roughly matches the width of your paper, but do not lock it.

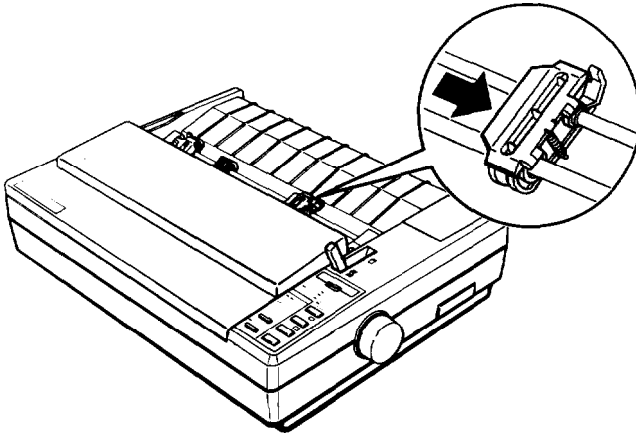

6. Move the paper support midway between the two sprocket units.

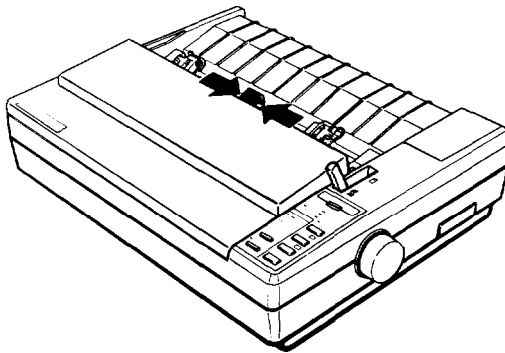

7. Open both sprocket covers.

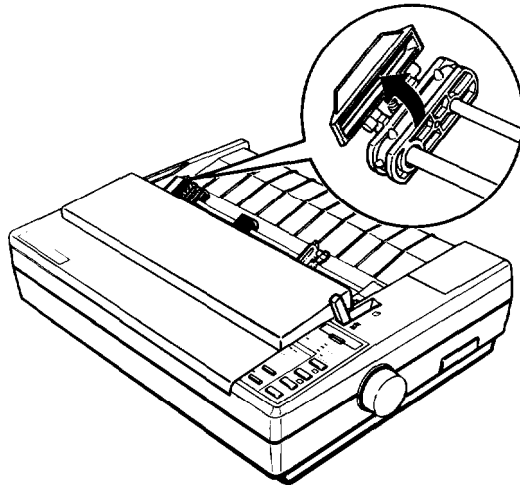

Note: Make sure that your paper has a clean, straight edge before inserting it into the printer.

8. Fit the first three holes in the paper over the pins of both sprockets.

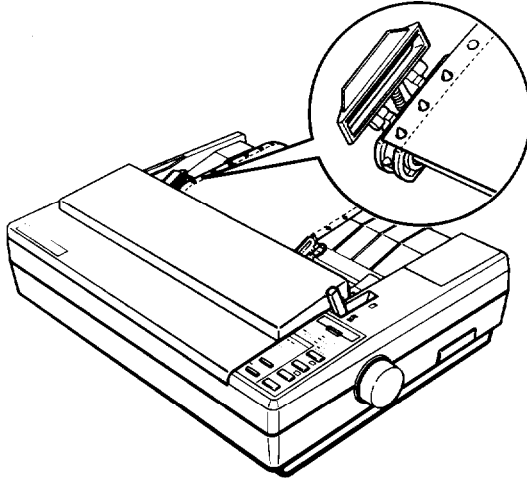

9. Close the sprocket covers.

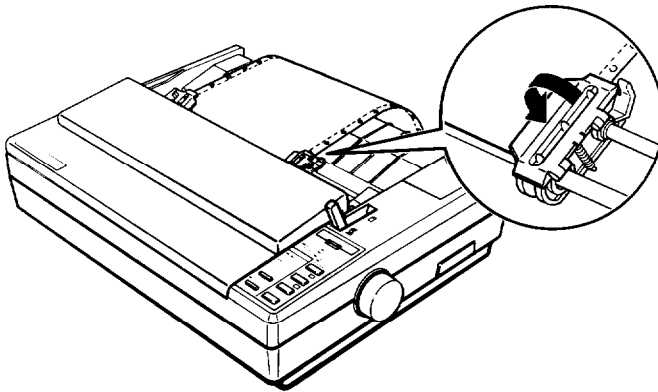

# Using Continuous Paper

10. Slide the right sprocket unit to a position where the paper is straight and has no wrinkles. Then lock it in place.

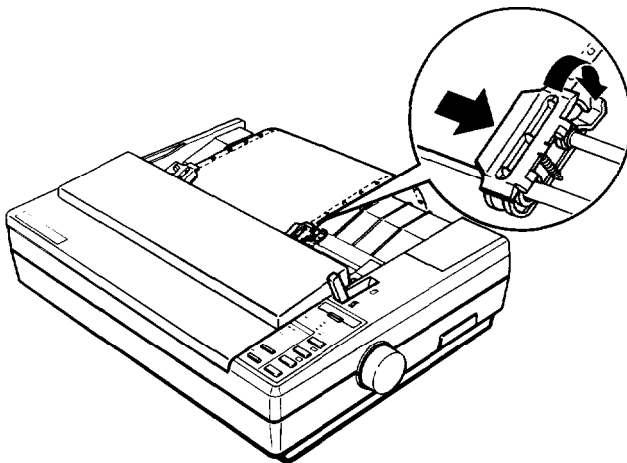

11. Reattach the paper guide. Then slide the edge guides apart to the sides of the paper guide as shown.

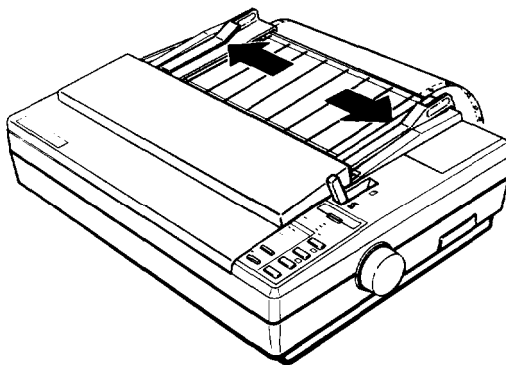

12. Turn on the printer. It will beep because there is no paper in the printer. Then press the LOAD/EJECT button to feed paper to the loading position.

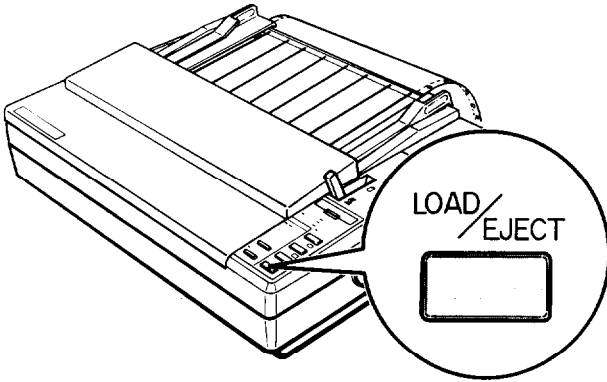

13. Press the ON LINE button to set the printer on line so that it can accept data.

The printer remembers the loading position and advances each page to the same position. If you need to adjust the loading position, use the micro-adjustment feature. See Adjusting the Loading Position in Chapter 3.



**CAUTION:** Never adjust the loading position using the platen knob and never turn the platen knob while the printer is turned on.

**Note:** Before you begin printing, check the page length and skip over perforation settings; readjust the settings if necessary. See Chapter 3 for details.

## Switching Between Continuous and Single Sheets

Even with continuous paper loaded in the printer, you can easily switch to single-sheet printing without removing the continuous paper from the tractor.

### Switching to Single Sheets

To switch from continuous paper to single sheets, you remove the last printed document and then back the continuous paper out of the way. Follow the steps below.

1. If the printer is on line, press the ON LINE button to set the printer off line.
2. Tear off any outgoing sheets. If the end of the last printed sheet has not reached the tear-off edge, you need to press the FORM FEED button to advance your document to a point where it can be easily removed.

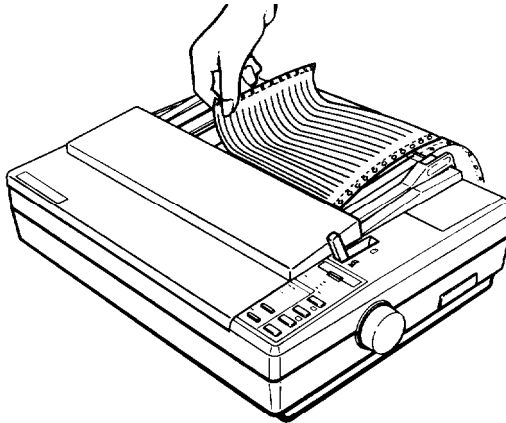



**CAUTION:** Make sure you tear off your printed document before pressing the LOAD/EJECT button. Reverse-feeding several pages at a time may result in a paper jam. This is especially true for narrow paper (less than 6 inches or 150 mm wide).

3. Press the LOAD/EJECT button to feed the continuous paper backward out of the printer and into the standby position. The paper is still attached to the tractor but no longer in the paper path.

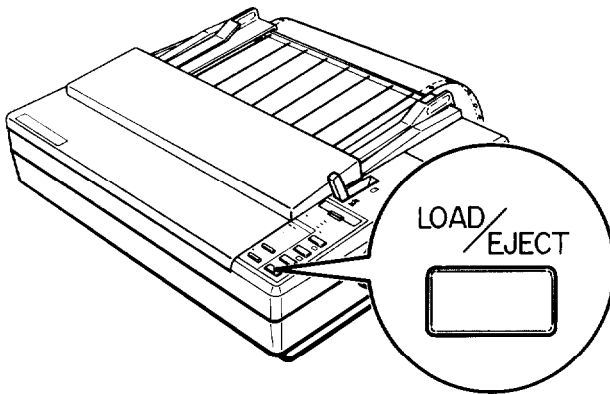

Note: Pressing the LOAD/EJECT button once may not feed the paper far back enough to reach the standby position. If the PAPER OUT light does not come on, you need to press the LOAD/EJECT button again. With normal-width continuous paper, you can press the LOAD/EJECT button up to three times. If, however, you are using narrow paper (between 4 and 6 inches or 100 and 150 mm) you should only press the LOAD/EJECT button once. Also, do not use this button to eject labels.





**CAUTION:** Never feed labels backward through the printer. Labels can easily come off the backing sheet and jam the printer.

4. Push the paper release lever back to the single sheet position.

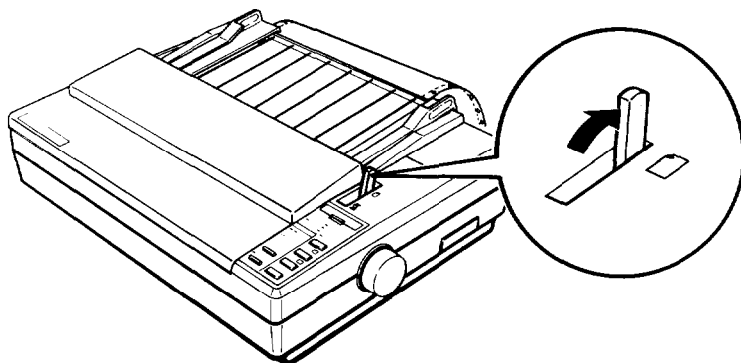

5. Stand the paper guide upright and adjust the edge guides to roughly match the width of your paper.

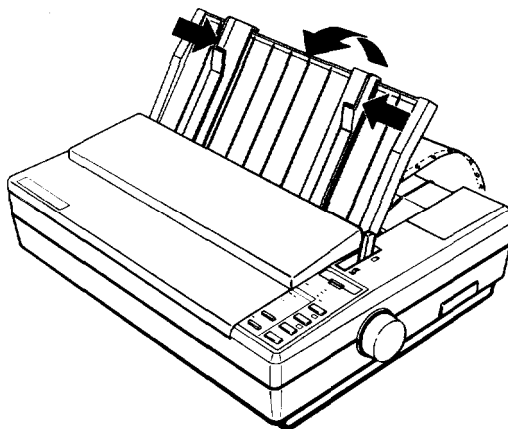

6. Insert a sheet of paper between the edge guides until it meets resistance. Slide the edge guides to match the width of your paper.

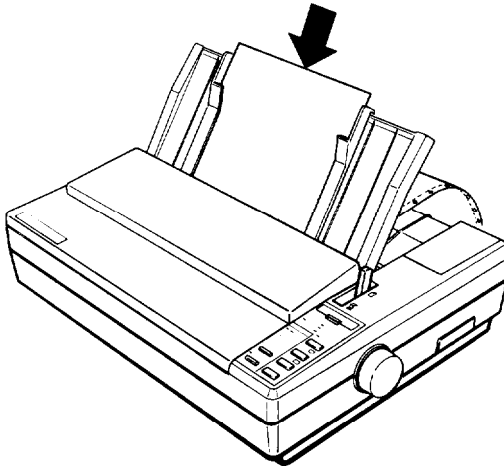

After about two seconds, the printer loads the paper automatically and is set ON LINE so that it can accept data from your computer.

Note: If the platen turns without loading the paper, press the ON LINE button to take the printer off line. Then remove the paper and reinsert it more firmly.

### Switching Back to Continuous Paper

It is easy to switch back to printing with continuous paper. Before switching to continuous paper, make sure that the single sheet is ejected and the printer is off line.

1. Slide the edge guides apart so they do not interfere with continuous paper feeding.

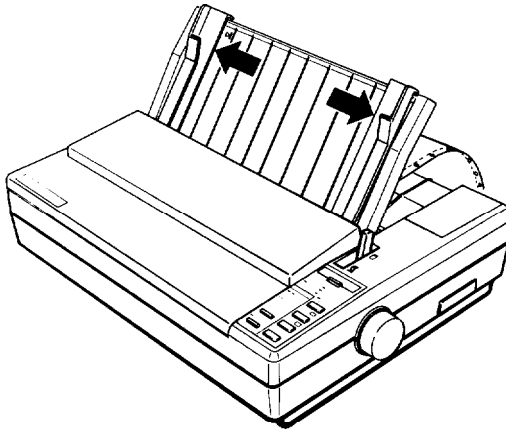

2. Lower the paper guide onto the printer.

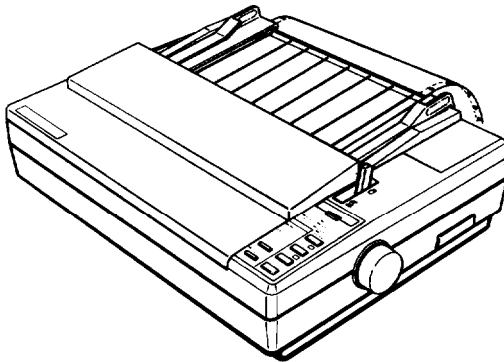

3. On the standard width printer, pull the paper release lever forward to the continuous paper position.

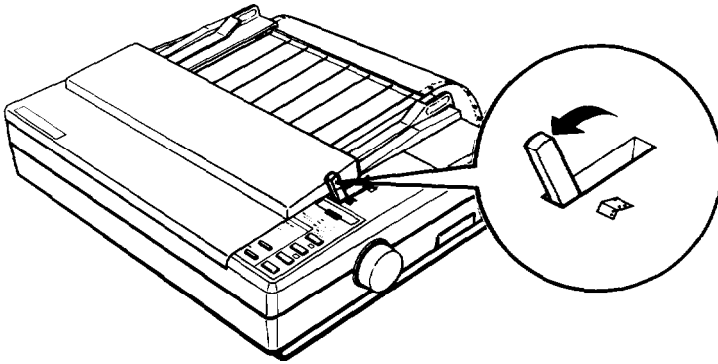

On the wide carriage printer, set the paper release lever to the middle position for continuous paper feeding.

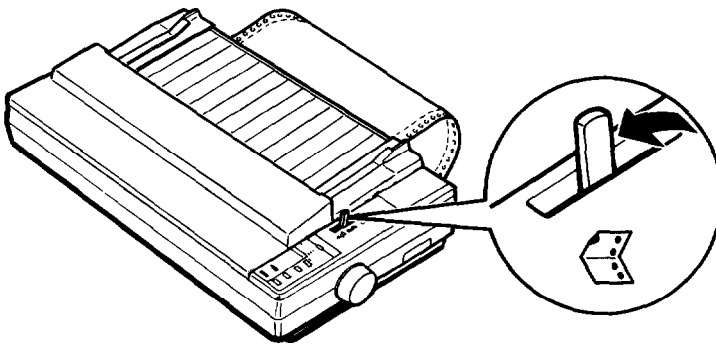

## Switching Between Continuous and Single Sheets

4. Press the LOAD/EJECT button to feed the continuous paper to the loading position.

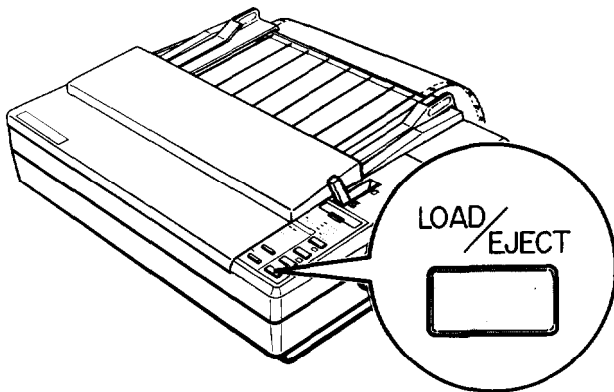

5. Press the ON LINE button to set the printer on line so that it can accept data.

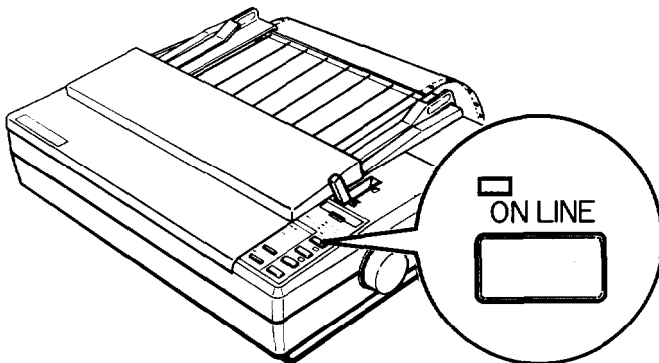

---

## Printing on Special Paper

In addition to printing on single sheets and continuous paper, your printer can also print on a wide variety of paper types, including multi-part forms, labels, and envelopes.

Before printing on special types of paper, you need to change the paper thickness setting.



**CAUTION:** When printing on multi-part forms, labels, or envelopes, make sure that your application program settings keep the printing entirely within the printable area.

For multi-part forms and labels you should not print any closer than one-half inch from either side of the paper.

For information on the printable area for envelopes, see Envelopes later in this chapter.

### The Paper Thickness Lever

To accommodate various thicknesses of paper, the printer is equipped with a paper thickness lever that can be set to seven positions (standard width printer) or eight positions (wide carriage printer). These positions are identified by a scale on the printer next to the lever.

To change the paper thickness setting, follow these steps.

1. Make sure that the printer is turned off. Then remove the printer cover.



**WARNING:** If the printer has just been in use, the print head may be hot. Allow it to cool before touching it.

2. Slide the print head to the middle of the printer.

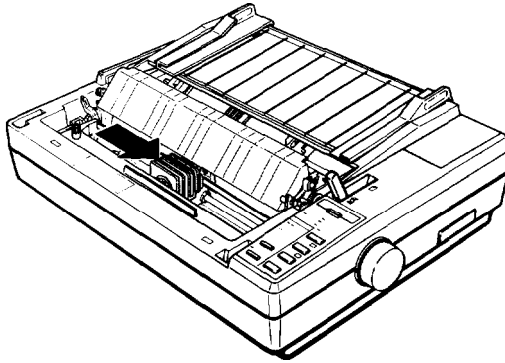

3. Select the paper thickness you want according to the table on the next page. For normal use, the lever should always be set to position 2 on the scale.

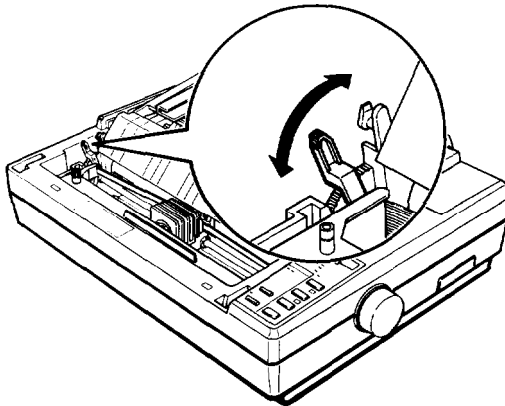

**Note:** If you have installed the optional film ribbon cartridge, set the paper thickness lever to position 1.

Paper Type	Lever Position
Paper (single sheets or continuous paper with film ribbon installed)	1
Paper (single sheets or continuous)	2
Thin paper	2
24 lb paper	3
Multi-part forms P-sheet	3
3-sheet	4
Labels	4
Envelopes Air mail	4 or 5
Plain	6
Bond (20 lb)	6
Bond (24 lb)	7

Note: When the lever is set to position 4 or higher, the printing speed is reduced.

#### 4. Reattach the printer cover.

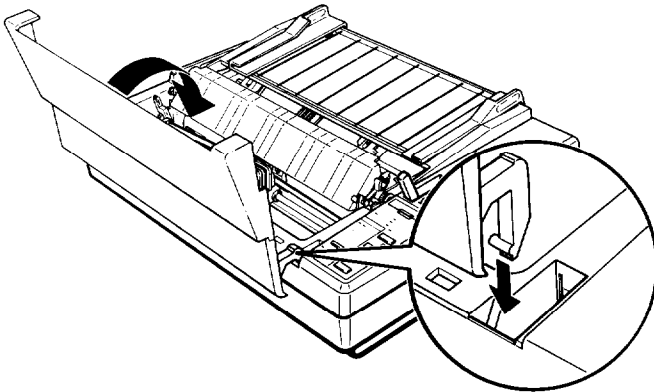



To help you check the position of the paper thickness lever, the orange MULTI-PART light on the control panel comes on if the lever is set to position 4 or higher.



**CAUTION:** Always return the lever to position 2 when you go back to printing on ordinary paper. Continuous printing with the lever set at a position higher than 2 can shorten the life of the print head. Printing past the edge of envelopes, multi-part forms, labels, or thicker-than-normal paper can damage the print head.

## Multi-part Forms

With the built-in tractor unit, your printer can print on continuous multi-part forms. You can use multi-part forms that have up to three parts including the original. Make sure you set the paper thickness lever to the proper position.

Except for the paper thickness lever setting, you load multi-part paper the same way as continuous paper. For details, see Loading Continuous Paper in this chapter. Also see Page Length and Adjusting the Loading Position in Chapter 3.

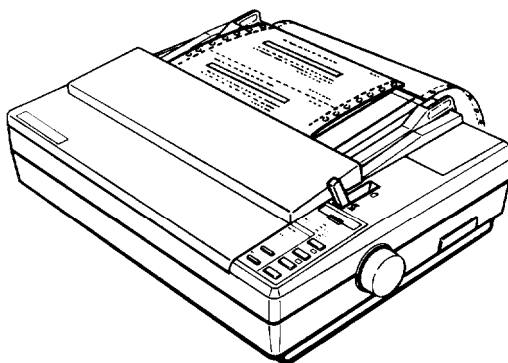



**CAUTION:** Do not use multi-part forms with the single-sheet feeding system or the optional cut sheet feeder.

## Labels

If you need to print labels, always use labels mounted on a continuous backing sheet with sprocket holes for use with a tractor. Do not try to print labels as single sheets because labels on a shiny backing sheet almost always slip a little.

You load labels the same way that you load continuous paper except that the paper thickness lever must be adjusted for printing labels. See Loading Continuous Paper earlier in this chapter. For the correct paper thickness setting, see The Paper Thickness Lever earlier in this chapter.

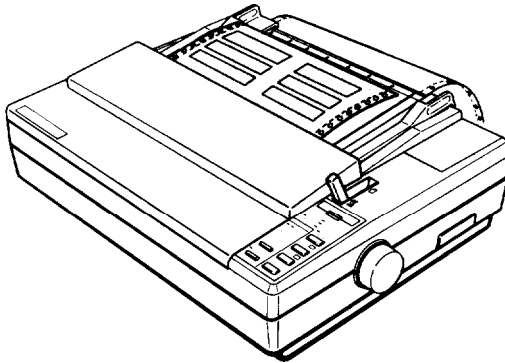



**CAUTION:** Never feed labels backward through the printer. Labels can easily peel off the backing and jam the printer. Therefore, never use the LOAD/EJECT button to eject labels. Also, never use the short tear-off function with labels. (Be sure to set DIP switch 2-2 to off.) If a label does become stuck in the printer, contact your dealer or call the Consumer Information number listed in Where to Get Help.

Because labels are especially sensitive to temperature and humidity, always use them under normal operating conditions. Don't leave labels loaded in the printer between jobs; they curl around the platen and may jam when you resume printing.

## **Envelopes**

You can feed envelopes individually using the single-sheet loading feature. Before loading envelopes, adjust the position of the paper thickness lever. See The Paper Thickness Lever earlier in this chapter.

When manually feeding an envelope, you may have to push it down slightly while pressing the LOAD/EJECT button to get it to feed properly.

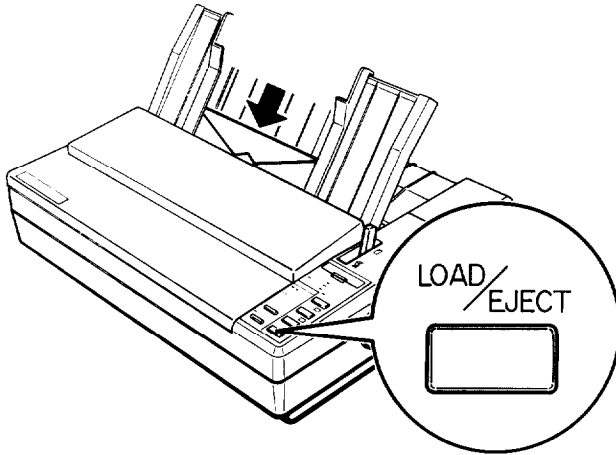

**CAUTION:** The printable area for envelopes is shown on the next page. The print head must not go past the left or right edge of the envelope or other thick paper. Make sure that the page setup of your application program keeps the printing entirely within this printable area.

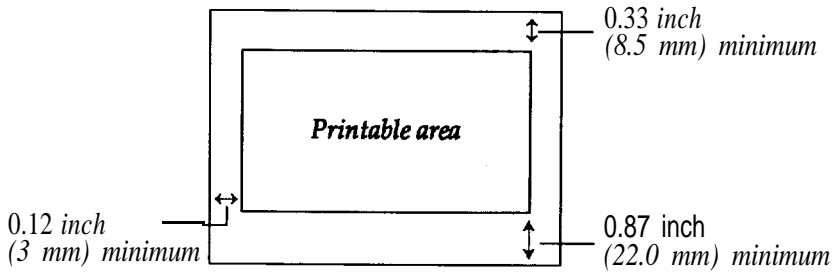

Note: Envelope printing is only available at normal temperature (40°F to 95°F or 5°C to 35°C).

To make sure that the printing fits within the printable area, always print a test sample using a normal sheet of paper before printing on envelopes.

# Chapter 3

## Using the Printer

<b>Operating</b> the Control Panel .....	3-2
Selecting Typestyles .....	3-6
Character Fonts .....	3-6
Condensed Mode .....	3-10
Setting the DIP Switches. ....	3-11
Changing a DIP Switch Setting .....	3-11
The DIP Switch Tables .....	3-12
The DIP Switch Functions .....	3-14
Page Length .....	3-15
Skip Over Perforation .....	3-16
Adjusting the Loading Position. ....	3-17
Using Micro-adjustment. ....	3-17
Using Short Tear-off .....	3-19
Adjusting the Tear-off Position. ....	3-20
Selecting an International Character Set .....	3-22
Choosing a Character Set. ....	3-24
Using the Data Dump Mode .....	3-26

# Operating the Control Panel

The indicator lights give you the current status of the printer. The buttons and paper handling functions let you control many of the printer settings.

## Lights

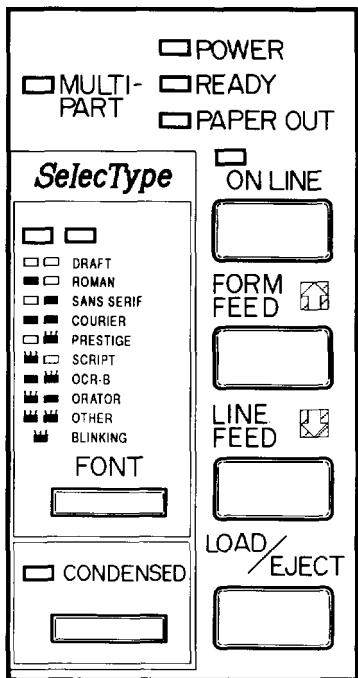

### MULTI-PART (orange)

On when the paper thickness lever is set to position 4 or higher. When this light is blinking, the micro-adjustment function can be used.

### POWER (green)

On when the POWER switch is on and power is supplied.

### READY (green)

On when the printer is ready to accept input data. Flickers during printing.

### PAPER OUT (red)

On when the printer is out of paper or when continuous paper is in the standby position.

### ON LINE (green)

On when the printer is on line and ready to accept data.

# Buttons

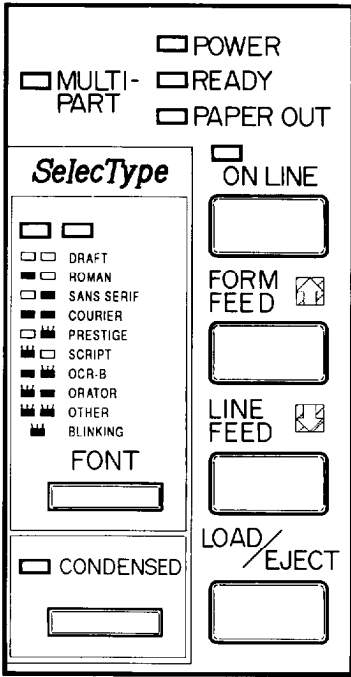

## ONLINE

This button controls the printer's on line and off line status. Press this button to put the printer on line or to take it off line. When the printer is on line, the ON LINE light is on and the printer can receive and print data from the computer.

## FORMFEED

When the printer is off line, press this button to eject a single sheet of paper or to advance continuous paper to the top of the next page.

## LINE FEED

When the printer is off line, press this button to advance the paper one line, or hold it down to advance the paper continuously.

## LOAD/EJECT

This button is used to feed paper to the loading position or to eject paper that is already loaded. Paper is ejected forward if the paper release lever is set to the single-sheet position and backward (out of the paper path) if the release lever is set to the continuous paper position.



# SelectType

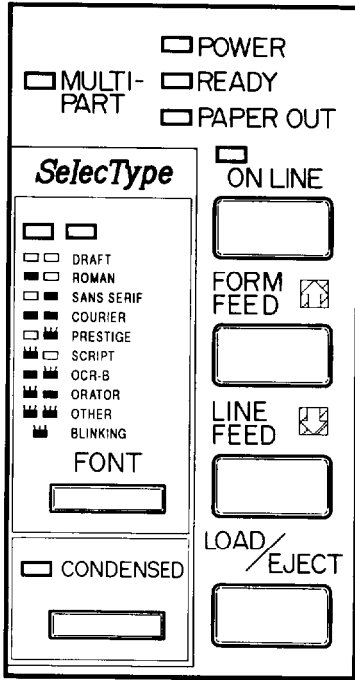

## FONT

Press this button to select a font. The two orange indicator lights show the selected font. See Selecting Typestyles later in this chapter.

## CONDENSED

Press this button to turn the condensed mode on and off. The orange indicator light is on when the printer is in the condensed mode. In the condensed mode, all characters are printed at approximately 60 percent of their normal width.

## Other Control Panel Features

The control panel of your printer also gives you access to several special functions.

- Self test:** Both a draft and Letter Quality self test function are built into the printer. The self test printout lets you check the current DIP switch settings and operating status of the printer. You can start the printer's self test by holding down the LINE FEED button or the FORM FEED button while turning on the printer. See *Testing the Printer* in Chapter 1 for more information.
- Micro-adjustment:** By pressing the FORM FEED button immediately after loading paper or when using short tear-off, you can make fine adjustments to the loading and short tear-off positions. These positions can only be adjusted while the MULTI-PART light is blinking. See *Adjusting the Loading Position and Using Short Tear-off* later in this chapter.
- Data dump:** By holding down both the LINE FEED and the FORM FEED buttons while you switch on the printer, you turn on the data dump mode. This feature allows advanced users to locate the source of communications problems between the computer and printer. See *Using the Data Dump Mode* for more information.

## Selecting Typestyles

You can produce a wide range of typestyles by selecting different character fonts, widths, and other enhancements from the SelecType control panel or by using software commands. This section describes only the features controlled by SelecType. To use software commands, see the Command Summary in Chapter 9.

You can use the SelecType section of the control panel to choose fonts and condensed printing. Orange lights indicate which features you have chosen.

**Note:** The settings you select using the SelecType panel remain valid even after you turn off, reset, or initialize the printer. However, commands from your application program temporarily override the SelecType settings.

Some application programs are designed to control all typestyle functions. These programs cancel all previous typestyle settings with software commands. Because these commands override SelecType settings, you should use the program's print options instead of SelecType to select your typestyles. If SelecType does not work with a particular application, check your software manual for instructions on selecting typestyles.

### Character Fonts

Your printer has ten built-in fonts: draft, Epson Roman, Epson Sans Serif, Epson Courier, Epson Prestige, Epson Script, OCR-A, OCR-B, Epson Orator, and Epson Orator-S. Eight of the fonts are selectable from the SelecType feature of the front panel.

# SelectType

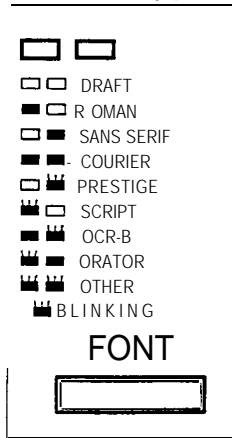

When you press the FONT button, the printer scrolls through eight of the ten built-in fonts. The indicator lights show the selected font.

indicates the light is off.

indicates the light is on.

indicates the light is blinking.

You use the software command ESC k to select the other two built-in fonts:

ESC k 6    OCR-A

ESC k 8    Epson Orator-S

When you select one of these fonts, the indicator lights show the OTHER pattern. See the Command Summary in Chapter 9 for details on software commands.

The following samples show the character set available for each font.

## DRAFT

!"#\$%&'()\*+,-./0123456789:;<=>?àABCDEF GHIJK  
LMNOPQRSTUVWXYZ°ç§^\_`abcdefghijklmnopqrstuv  
wxyzéùè"Çüéääää&çêëëïïïÀĀĂĔĂĖĂØöðûÿŸŮčłƒłƒáíó  
ůňÑ&@;~½¼;«»

## Epson Roman

!"#\$%&'()\*+,-./0123456789:;<=>?àABCDEF GHIJK  
LMNOPQRSTUVWXYZ°ç§^\_`abcdefghijklmnopqrstuv  
wxyzéùè"Çüéääää&çêëëïïïÀĀĂĔĂĖĂØöðûÿŸŮčłƒłƒáíó  
ůňÑ&@;~½¼;«»

## Epson Sans Serif

!"#\$%&'()\*+,-./0123456789:;<=>?àABCDEF GHIJK  
LMNOPQRSTUVWXYZ°ç§^\_`abcdefghijklmnopqrstuv  
wxyzéùè"Çüéääää&çêëëïïïÀĀĂĔĂĖĂØöðûÿŸŮčłƒłƒáíó  
ůňÑ&@;~½¼;«»

## Epson Courier

!"#\$%&'()\*+,-./0123456789:;<=>?àABCDEF GHIJK  
LMNOPQRSTUVWXYZ°ç§^\_`abcdefghijklmnopqrstuv  
wxyzéùè"Çüéääää&çêëëïïïÀĀĂĔĂĖĂØöðûÿŸŮčłƒłƒáíó  
ůňÑ&@;~½¼;«»

## Epson Prestige

!"#\$%&'()\*+,-./0123456789:;<=>?àABCDEF GHIJK  
LMNOPQRSTUVWXYZ°ç§^\_`abcdefghijklmnopqrstuv  
wxyzéùè"Çüéääää&çêëëïïïÀĀĂĔĂĖĂØöðûÿŸŮčłƒłƒáíó  
ůňÑ&@;~½¼;«»

## Epson Script

!"#\$%&'()\*+,-./0123456789:;<=>?àABCDEFGHIJK  
LMNOPQRSTUVWXYZ°ç\$^\_`abcdefghijklmnopqrstuv  
wxyzéùè"ÇüéääääçéèèèîîîîÄÅÆæÆöööüÿÜÜφ&¥Ptíáíó  
úñÑāō¿¡¬½¼;«»

## OCR-B

!"#\$%&'()\*+,-./0123456789:;<=>?àABCDEFGHIJK  
LMNOPQRSTUVWXYZ°ç\$^\_`abcdefghijklmnopqrstuv  
wxyzéùè"ÇüéääääçéèèèîîîîÄÅÆæÆöööüÿÜÜφ&¥Ptíáíó  
úñÑāō¿¡¬½¼;«»

## OCR-A

!"#\$%&'()\*+,-./0123456789:;<=>?àABCDEFGHIJK  
LMNOPQRSTUVWXYZ°ç\$^\_`abcdefghijklmnopqrstuv  
wxyzéùè"ÇüéääääçéèèèîîîîÄÅÆæÆöööüÿÜÜφ&¥Ptíáíó  
úñÑāō¿¡¬½¼;«»

Note: The OCR-B and OCR-A fonts can be read by an optical character reader (also known as a document reader or image scanner) for input into another computer. Print enhancements, such as bold and underlining, cannot be read by an actual character reader.

## Epson Orator

!"#\$%&'()\*+,-./0123456789:;<=>?ÀABCDEFGHIJK  
LMNOPQRSTUVWXYZ°ç\$^\_`ABCDEFGHIJKLMNOPQRSTU  
VWXYZÉÚÈ ÇÜÉÁÀÀÀÇÉÈÈÈÎÎÎÎÄÅÆæÆöööüÿÜÜφ&¥Ptíáíó  
úñÑāō¿¡¬½¼;«»

## Epson Orator-S

!"#\$%&'()\*+,-./0123456789:;<=>?`àABCDEFGHIJK  
LMNOPQR\$TUVWXYZ çš ˆ abcdefghijklmnopqrstuv  
wxyzéùè ÇüéâãäåçèëèÏîïÀÆæÆöööüüÿÖÜç&¥Ptfaíó  
úñÑQqZ¿¬½&¡«»

The draft mode uses fewer dots per character for high-speed printing, which makes it ideal for rough drafts and editing work.

The other fonts are Letter Quality (LQ) fonts. Letter Quality takes a little longer to print, but produces nicely formed characters suitable for most documentation requirements.

### Condensed Mode

You can use the condensed mode to change the size of printed characters. In the condensed mode, characters are approximately 60 percent of the width of normal characters. Hence, condensed printing is very useful for spreadsheets and other applications where you need to print the maximum amount of information on a page. You can combine the condensed mode with 10 cpi, 12 cpi, and proportional printing, but not 15 cpi.

To select the condensed mode, simply press the CONDENSED button so that the orange indicator light comes on. To turn off the condensed mode, press the button again.

The following printout compares normal 10 and 12 cpi with condensed 10 and 12 cpi. The condensed 10 cpi is 17 cpi, and the condensed 12 cpi is 20 cpi.

#### **This is 10 CPI printing.**

This is condensed 10 CPI printing,

#### **This is 12 CPI printing.**

This it condensed 12 CPI printing,

# Setting the DIP Switches

The printer has two sets of DIP switches located under a small cover above the control panel. By changing the settings of these switches, you can control various printer features, such as the character set and page length. The new settings become effective when the printer is turned on, reset, or initialized.

DIP switch settings are shown in the DIP switch tables later in this section. Descriptions of all the DIP switch functions follow the tables.

## Changing a DIP Switch Setting

To change a DIP switch setting, follow these steps:

1. Turn off the printer.
2. Open the DIP switch cover and use a pointed object, such as a pen, to change the DIP switch settings. A DIP switch is on when it is up, and off when it is down.

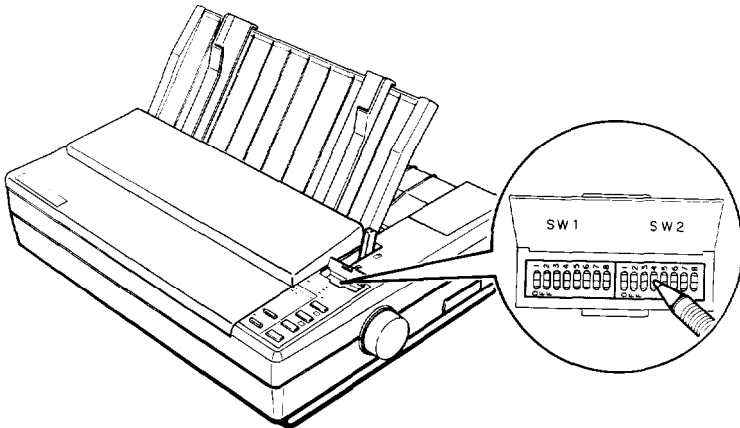

The new DIP switch settings take effect when the printer is turned on.



## The DIP Switch Tables

The tables below show the settings for each DIP switch. The page numbers indicate where the feature is described.

### *DIP switch 1*

SW	Description	ON	OFF	Page
1-1 1-2 1-3	International character set/ Graphics character set	See tables 1 and 2		3-22 3-24
1-4 1-5	Page length	See table 3		3-15
1-6	Condensed mode on/off	Condensed	Normal	3-10
1-7	Character set	Graphics	Italics	3-24
1-8	Cut sheet feeder mode on/off	On	Off	5-2

### *DIP switch 2*

SW	Description	ON	OFF	Page
2-1	Not used	—	—	—
2-2	Tear-off mode	On	Off	3-14
2-3	1-inch skip over perforation	On	Off	3-16
2-4	Auto line feed	On	Off	3-14
2-5	Input buffer capacity	8 KB	1 KB*	3-14
2-6	Graphics print direction	Bidirect.	Unidirect.	3-14
2-7 2-8	Character spacing	See Table 4		3-13

\* Required for use of user-defined (download) characters.

*Table 1 International character sets*

<b>Country</b>	<b>SW 1-1</b>	<b>SW 1-2</b>	<b>SW 1-3</b>	<b>SW 1-7</b>
USA	ON	ON	ON	OFF
France	ON	ON	OFF	OFF
Germany	ON	OFF	ON	OFF
UK	ON	OFF	OFF	OFF
Denmark	OFF	ON	ON	OFF
Sweden	OFF	ON	OFF	OFF
Italy	OFF	OFF	ON	OFF
Spain	OFF	OFF	OFF	OFF

*Table 2 Graphics character sets*

<b>Graphics character sets</b>	<b>SW 1-1</b>	<b>SW 1-2</b>	<b>SW 1-3</b>	<b>SW-17</b>
PC 437 (United States)				
Epson Extended Graphics	ON	ON	ON	ON
PC 850 (Multilingual)	ON	ON	OFF	ON
PC 860 (Portugal)	ON	OFF	ON	ON
PC 863 (Canada-French)	ON	OFF	OFF	ON
PC 865 (Norway)	OFF	ON	ON	ON

The graphics character sets are also called code page tables.

*Table 3 Page length selection*

<b>Page length</b>	<b>SW 1-4</b>	<b>SW 1-5</b>
11 inches	OFF	OFF
12 inches	ON	OFF
8.5 inches	OFF	ON
11.7 inches	ON	ON

*Table 4 Character spacing*

<b>Character spacing</b>	<b>SW 2-7</b>	<b>SW 2-8</b>
10 cpi	OFF	OFF
12 cpi	ON	OFF
15 cpi	OFF	ON
Proportional	ON	ON

## The DIP Switch Functions

### Auto line feed

When auto line feed is on (DIP switch 2-4 on), each carriage return code (CR) is automatically followed by a line feed code (LF).

### Input buffer capacity

The input buffer stores data from your computer. If you want to free your computer for other tasks while the printer prints, change the setting of switch 2-5 to 8 KB (on). Before using user-defined characters, however, be sure to set the input buffer to 1 KB (off).

### Printing direction

With unidirectional printing, the print head prints in one direction only. This allows for precise vertical alignment, making it ideal for printing graphics such as lines and boxes. With bidirectional printing, the print head prints in both directions. This is faster than unidirectional printing.

When DIP switch 2-6 is off, the printer prints unidirectionally; when it is on, the printer prints bidirectionally. Either setting can be overridden by a software command (ESC U).

To achieve precise vertical alignment without the slower printing speed caused by unidirectional printing, see your dealer for adjustment of your bidirectional print settings.

### Tear-off mode

When DIP switch 2-2 is on, the short tear-off mode is on. This feature automatically advances continuous paper to the tear-off position, and then reverse-feeds the paper to the loading position. See Using Short Tear-off later in this chapter.



**CAUTION:** Do not use the short tear-off mode with labels.

## Page Length

You can select one of four page lengths using DIP switches 1-4 and 1-5.

Page length	SW 1-4	SW 1-5
8.5 inches (216 mm)	OFF	ON
11 inches (279 mm)	OFF	OFF
11.7 inches (296 mm)	ON	ON
12 inches (305 mm)	ON	OFF

**Note:** Be sure to set the page length to match the paper you are using.

Other page lengths can be set using the commands ESC C and ESC C 0. See the Command Summary in Chapter 9 for details.

**Note:** If you are using the cut sheet feeder, the page length is automatically set when you run the self test. See The Cut Sheet Feeder in Chapter 5 for details.

## Skip Over Perforation

By changing the setting of DIP switch 2-3, you can set skip over perforation to on or off. If this feature is on when using continuous paper, a one-inch margin is provided between the last printable line on one page and the first printable line on the next page. This feature is very convenient if your application program does not provide for top and bottom margins.

If you adjust your loading position correctly, you can get half of the margin at the bottom of one page and half at the top of the next page, as shown in the following illustration.

*DIP switch 2-3 ON (Skip over perforation ON)*

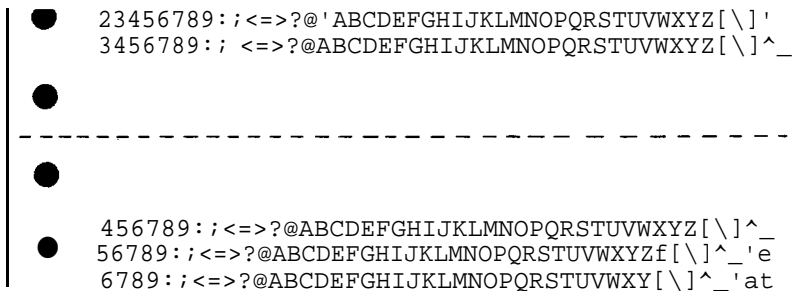

**Note:** Most application programs take care of top and bottom margins. Use skip over perforation only if your program does not provide these margins.

The skip over perforation setting can be set to values other than one inch by using the ESC N command. See the Command Summary in Chapter 9 for details.

## Adjusting the Loading Position

The loading position is the position of the paper when it has been automatically loaded by the printer.

This position is important because it determines where the printing begins on the page. If the printing is too high or too low on the page, change the loading position using the micro-adjustment feature described in the next section.



**CAUTION:** Never use the platen knob to feed paper except in case of a paper jam or other paper feeding problem. (If you need to use the platen knob, make sure the power is off.) If you need to adjust the loading position, always use the micro-adjustment feature.

Until the loading position is reset, the printer remembers this position even if it is turned off, and uses it as a reference point for feeding paper.

The micro-adjustment feature moves the paper in 1/180-inch increments to make fine adjustments to the loading position. Once you have used micro-adjustment to change the loading position of continuous paper, the printer remembers that position even after it is turned off.

When you use micro-adjustment to change the loading position of single-sheet paper, however, the printer does not remember this position after the power is turned off. When the power is turned back on, the loading position returns to its factory setting.

### Using Micro-adjustment

1. Make sure that the printer is turned on and that either a single sheet or continuous paper is loaded.

2. Press the ON LINE button. The MULTI-PART light begins to blink.

# MULTI-PART

Note: You can use the FORM FEED and LINE FEED buttons for micro-adjustment only while the MULTI-PART light is blinking.

3. Press the FORM FEED button to feed the paper forward or the LINE FEED button to feed the paper backward.

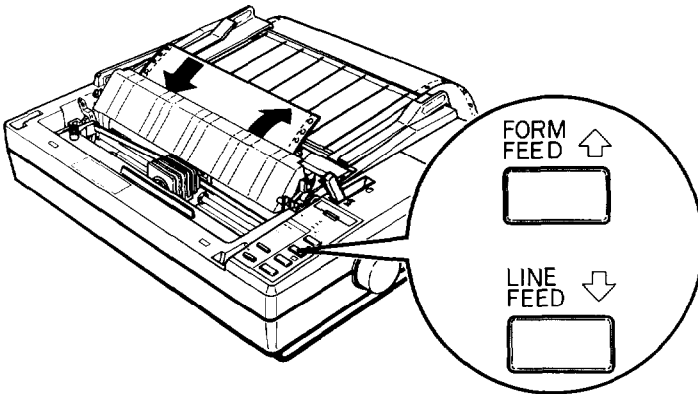

**Note:** When the paper reaches the factory-set loading position, the printer beeps and micro-adjustment feeding pauses for a moment before continuing. You can use this factory setting as a reference point when adjusting the printer's loading position. When the paper reaches either the minimum or maximum top margin, the printer beeps and the paper stops moving.

## Using Short Tear-off

When you are finished printing, the short tear-off feature automatically feeds the perforation of the continuous paper to the tear-off edge of the printer cover so that you can tear off the last sheet. When you resume printing, the paper feeds backward to the loading position. This feature lets you save the paper normally lost between documents.

To use this feature, set DIP switch 2-2 to on. Then load continuous paper in the normal way.

You can leave the short tear-off feature turned on (DIP switch 2-2 on) even when you are using single sheets. When you move the paper release lever to the singlesheet position, the short tear-off feature is disabled.



**CAUTION:** Never use short tear-off with labels. Otherwise, labels may come off their backing and jam the **printer.**

When you have finished printing, and if the perforation is at the top of form position, the printer automatically feeds the perforation of the continuous paper to the tear-off edge of the printer cover. You can then tear off the page using the tear-off edge as shown on the **next page.**



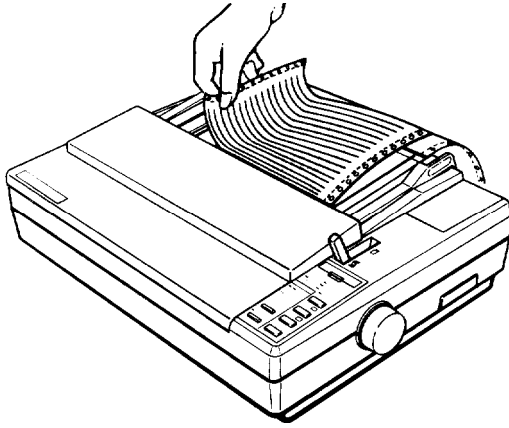

If the page perforation is not properly aligned with the tear-off edge, you can adjust the tear-off position using micro-adjustment, as described below.

Note: Short tear-off is performed whenever the printer receives a full page of data or a form feed, and no more data is received for three seconds.

When you resume printing after tearing off the sheet, the paper automatically feeds backward to the loading position before printing begins.

### **Adjusting the Tear-off Position**

If the paper's perforation does not meet the tear-off edge, follow these steps to adjust the tear-off position.

1. Make sure the printer feeds the paper to the tear-off position after printing the document.

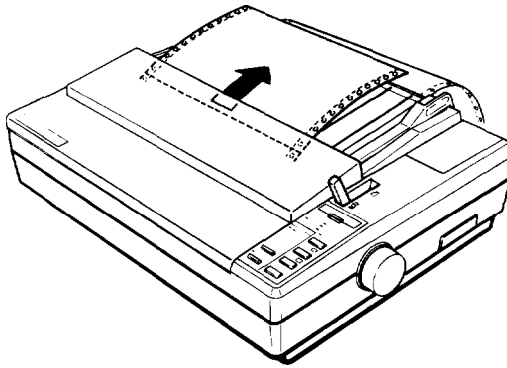

2. The MULTI-PART light should begin blinking, indicating that you can now use the micro-adjustment feature to make fine adjustments to the tear-off position.

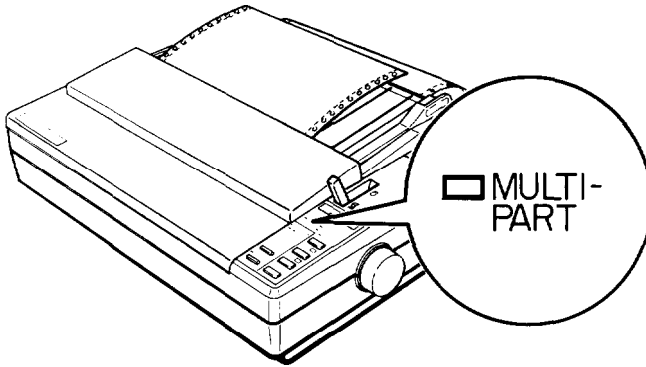

3. To make fine adjustments to the tear-off position, press the FORM FEED button to feed the paper forward or the LINE FEED button to feed it backward.

You can now tear off your document from the perforation and resume printing. The printer remembers this new tear-off position even after the printer is turned off.

## Selecting an International Character Set

International character sets provide you with the characters and symbols used in other languages. You can select one of eight international character sets by changing the DIP switch settings.

Whenever the printer is turned on, reset, or initialized, the character set selected by the DIP switches becomes the default character set.

To select an international character set, set DIP switches 1-1, 1-2, and 1-3 according to the table below.

**Note:** DIP switch 1-7 must be off. To select an international character set when DIP switch 1-7 is on, use the ESC R command.

This table also shows the characters that differ in each international character set.

Country	ASCII code hex											DIP SW			
	23	24	40	58	5C	5D	5E	60	7B	7C	7D	7E	1-1	1-2	1-3
0 U.S.A.	#	\$	@	[	\	]	^	'	{		}	~	ON	ON	ON
1 France	#	\$	à	•	ç	§	^	'	é	ù	è	¨	ON	ON	OFF
2 Germany	#	\$	§	Ä	Ö	Ü	^	'	ä	ö	ü	ß	ON	OFF	ON
3 U.K.	£	\$	@	[	\	]	^	'	{		}	~	ON	OFF	OFF
4 Denmark	#	\$	@	Æ	Ø	Å	^	'	æ	ø	å	~	OFF	ON	ON
5 Sweden	#	¤	É	Ä	Ö	Å	Ü	é	ä	ö	å	ü	OFF	ON	OFF
6 Italy	#	\$	@	•	\	é	^	ù	à	ò	è	ì	OFF	OFF	ON
7 Spain	¢	\$	@	;	Ñ	¿	^	'	¨	ñ	}	~	OFF	OFF	OFF

**Note:** To change the setting of a DIP switch, first turn off the printer, change the DIP switch setting, and then turn the printer back on.

In addition to the eight character sets shown on the previous page, the seven international character sets that follow can be selected with a software command, ESC R For more information, see the Command Summary in Chapter 9.

Country	ASCII code hex											
	23	24	40	5B	5C	5D	5E	60	7B	7C	7D	7E
8 Japan	#	\$	@	[	¥	]	^	'	{		}	~
9 Norway	#	¤	É	Æ	Ø	À	Û	é	æ	ø	å	ü
10 Denmark II	#	\$	É	Æ	Ø	À	Û	é	æ	ø	å	ü
11 Spain II	#	\$	á	í	Ñ	¿	é	'	í	ñ	ó	ú
12 Latin America	#	\$	á	í	Ñ	¿	é	ü	í	ñ	ó	ú
13 Korea	#	\$	@	[	₩	]	^	'	{		}	~
64 Legal	#	\$	§	°	'	"	¶	'	©	®	†	™

## Choosing a Character Set

DIP switch 1-7 selects either the italic character set or a graphics character set. The graphics character sets contain international accented characters, Greek characters, mathematic symbols, and character graphics for printing lines, corners, and shaded areas.

If you have an IBM® or IBM-compatible computer, select a graphics character set when you wish to print character graphics as they are displayed on the screen. Even if you select a graphics character set, you can still print ordinary text and italics. For italics, see your software manual or the description of the ESC 4 command in the Command Summary, Chapter 9.

Note: In most cases, a graphics character set is the preferred selection.

To select either the italics or a graphics character set, set DIP switch 1-7 according to the table below.

Character set	DIP SW 1-7
Italics	OFF
Graphics	ON

**Note:** To change the setting of a DIP switch, first turn off the printer, change the DIP switch, and then turn the printer back on.

You can also select the italics character set or a graphics character set using the ESC t command. See the Command Summary in Chapter 9.

When DIP switch 1-7 is on, the graphics character set is determined by the settings of DIP switches, 1-1, 1-2, and 1-3.

Character set	SW 1-1	SW 1-2	SW 1-3
PC 437 (United States) Epson Extended Graphics	ON	ON	ON
PC 850 (Multilingual)	ON	ON	OFF
PC 860 (Portugal)	ON	OFF	ON
PC 863 (Canada-French)	ON	OFF	OFF
PC 865 (Norway)	OFF	ON	ON

The graphics character sets are also called code page tables.

Sample printouts of the italic character set and the graphics character sets are shown in the Appendix.

**Note:** When DIP switch 1-7 is off, DIP switches 1-1, 1-2, and 1-3 select an international character set.

## Using the Data Dump Mode

The data dump mode is a special feature that makes it easy for experienced users to identify the cause of communication problems between the printer and application programs. The data dump mode gives a printout of the codes reaching the printer.

To use the data dump mode, follow these steps:

1. Make sure the printer is loaded with either single sheet or continuous paper.

**Note:** Use paper at least 7.2 inches (182 mm) wide.

2. If the printer is on, switch it off, then hold down the FORM FEED and LINE FEED buttons at the same time you turn on the printer.

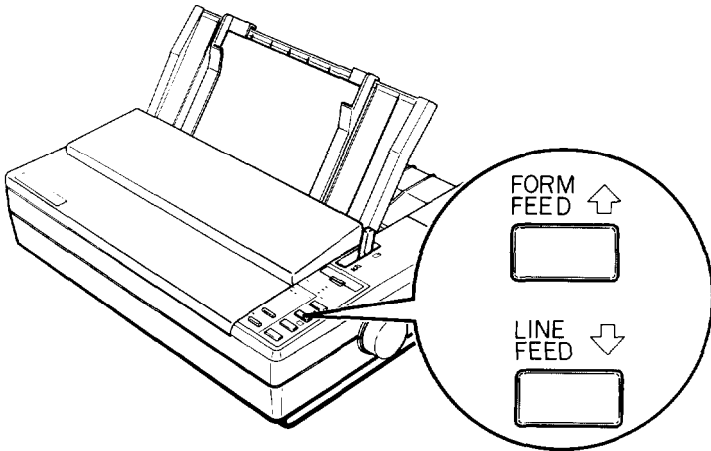

- Run any program that causes the printer to print (either an application program or one in any programming language). Your printer prints out all the codes sent to the printer, as shown below. (In order to print the last line, you will have to take the printer off line.)

```

18 40 1B 52 00 1B 74 01 ( 56 12 18 50 1B 70 00 .@.R..t..6..P.p.
20 20 54 68 69 73 20 6C ( 20 a1 6E 20 65 78 61 . This is an exa
6D 70 6C 65 20 6F 66 2C ( 20 64 61 74 61 20 64 mple of a aata d
75 6D 70 20 70 72 69 6E ( F 75 74 2E 20 54 68 ump printout. Th
69 73 20 66 65 61 74 75 ( 5 20 6D 61 68 65 73 is feature makes
0A 20 20 20 20 20 69 74 ( 5 61 73 79 20 66 6F it easy to

```

On the left side of the printout all the codes are printed in hexadecimal format. On the right side of the printout all printable characters are printed, and others, such as control codes, are represented by dots.

- To turn off the data dump mode after you have taken the printer off line, turn off the printer.

By comparing the characters printed in the text field on the right side of the data dump printout with the printout of hex codes, you can check which codes are being sent to the printer.

To interpret the data dump printout, examine the first three hex codes on the second line of the printout sample (20 20 54). Each hex code 20 represents a space; hex code 54 represents the letter T. Check the second line of the text field on the right side of the printout and you will find the letter T preceded by two spaces.

The chart below interprets the first eight codes.

Hex codes	Command	Function
1B40	ESC	Initialize printer
1B5200	ESC R 0	Select USA character set
1B7401	ESC t 1	Select PC 437 (Epson Extended Graphics)



# Chapter 4

## Software and Graphics

Enhancing Your Printing .....	4-2
Character Spacing .....	4-2
Character Size .....	4-3
Special Effects and Emphasis. ....	4-4
Graphics.. .....	4-7
The Print Head. ....	4-8
The Graphics Command .....	4-11
Column Reservation Numbers .....	4-12
A Simple Graphics Program .....	4-12
Designing Your Own Graphics. ....	4-13
User-defined Characters. ....	4-17
Designing Your Characters .....	4-17
Defining Your Characters .....	4-19
Sending Information to Your Printer .....	4-21
Printing User-defined Characters .....	4-24
Copying ROM Characters to RAM. ....	4-25
Letter Quality Characters, .....	4-26
Mixing Print Styles .....	4-27



# Enhancing Your Printing

You can obtain a wide variety of printing effects with your printer, from changing the number of characters per inch to using special effects on selected words and phrases. This section gives you a sampling of the features you may select with your software.

For software control of these features, see the instructions for your application programs or look up their specific commands in the Command Summary in Chapter 9.

## Character Spacing

To add greater variety to your documents, the printer has three cpi spacings, as well as proportional spacing. Each one can be selected with a software command.

For each of the built-in fonts, you can choose a character spacing of 10, 12, or 15 characters per inch, or proportional spacing. The printout below compares the three spacings:

**This is 10 cpi printing.**

This is 12 cpi printing.

This is 15 cpi printing.

As shown above, 15 cpi characters are only about two-thirds the height of 10 and 12 cpi characters. This makes 15 cpi particularly useful when you want to separate certain material from the main text.

In fixed cpi spacing each character is given the same amount of space. The width of proportional characters, however, varies from character to character. For example, a narrow letter like *i* takes less space than a wide letter like *W*. The width of each proportional character is given in the Appendix.

The following printout compares 10 cpi spacing with proportional spacing:

This is 10 cpi printing.  
**This is proportional printing.**

Note: Proportional spacing is not available in the draft mode.

See the Print Size and Character Width commands in Chapter 9.

### **Character Size**

In addition to the basic cpi spacings and proportional spacing, the printer offers three other modes that can change the size of your printing. These modes are double-width, double-height, and condensed.

The doublewidth mode doubles the width of any size character, while the double-height mode doubles the height of any size character. These modes are useful for emphasizing document titles and headings in reports, but are usually not suitable for large amounts of text. These modes can also be combined to obtain even more impressive printing results.

**This is normal 10 cpi printing.**  
T h i s i s d o u b l e - w i d t h .

This is double-height,  
**This is double-width  
and double-height.**

Both 10 and 12 cpi printing can be reduced to about 60 percent of their normal width using the condensed mode. This mode is particularly useful for printing wide spreadsheets because condensed 12 cpi printing allows you to print up to 160 characters on an 8-inch line.

The condensed mode can be selected with a software command, or by using SelecType (see Chapter 3). Even if you turn the condensed mode on with SelecType, you can still turn it off with a software command.

Condensed 10 cpi gives you many characters on a line,

Condensed 12 cpi gives you even more characters on a line.

Widening or narrowing the characters also widens or narrows the spaces between words. Because word processors usually create a left margin by printing spaces, you may need to change the left margin and the number of characters on a line to keep the margins correct if you change character widths.

See the Print Size and Character Width commands in Chapter 9.

### **Special Effects and Emphasis**

The printer offers two ways of emphasizing text and also allows you to use underlining, superscripts, subscripts, and italics. These features can be controlled directly by software commands. Many application programs can also produce some of these effects. See your application program manual for details.

#### **Emphasized and double-strike printing**

Emphasized and double-strike printing can give words and phrases added prominence. In emphasized mode, each character is printed twice as the print head moves across the paper, with the dots in the second pass printed slightly to the right of the first pass. This process produces darker, more fully formed characters.

In double-strike mode, the print head prints each line twice, making the text bolder. For even greater boldness, emphasized and double-strike can be combined. The following samples show the different effects you can achieve using these modes alone and in combination.

**This is ROMAN printing.**  
**This is ROMAN, emphasized.**  
**This is ROMAN, double-strike.**  
**This is ROMAN, with both.**

See the ESC E and ESC G commands in Chapter 9.

Italic printing

You can print italics by using the ESC 4 software command (see Chapter 9). This is true no matter how DIP switch 1-7 is set.

**This is ROMAN printing.**  
***This is ROMAN italics.***

**Underlining, strike-through, and overlining**

The underline, strike-through, and overline modes are useful for highlighting selected text. This feature can be used to score spaces, subscripts, and superscripts without a break. You can choose from a variety of line styles, including single, double, broken, or continuous. See the ESC (-command in Chapter 9 for more information.

**This is continuous underlining.**

**This is broken overlining.**

## Superscripts and subscripts

Superscripts and subscripts can be used for printing footnote numbers and mathematical formulas. The example below shows underlining and subscripts combined in a mathematical formula.

$$\mathbf{average} = \frac{\mathbf{(a1 + a2 + ..... + an)}}{\mathbf{n}}$$

See the ESC S0 and ESC S1 commands in Chapter 9.

## Outline and shadow

The outline and shadow features are useful for adding variation and emphasis to text that you wish to stand out, such as headings. The following samples show the outline and shadow features individually, plus a combination of outline with shadow.

This is outline style.  
This is shadow style,  
This is outline With shadow.

See the ESC q command in Chapter 9.

# Graphics

The dot graphics mode allows your printer to produce pictures, graphs, charts, or almost any other pictorial image you can create. The quickest and easiest way to print graphics on your printer is to use a commercial graphics program. With such programs you may be able to print pictures and graphs like the ones on this page and the next by simply giving your software a few instructions.

If you use commercial software that produces graphics, all you need to know about dot graphics is how to use the software. The application program will take care of the printer. (Some programs call this bit image printing.) On the other hand, if you wish to do your own programming or merely wish to understand how this printer prints graphics, read on.

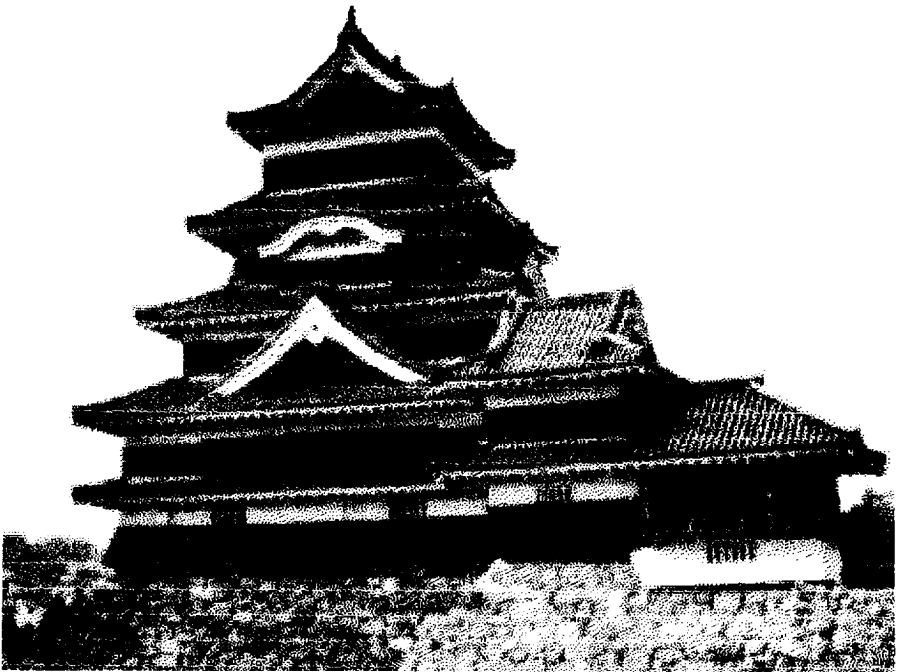

# Income Breakdown

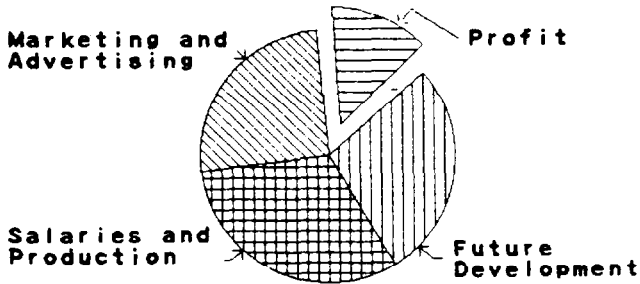

## The Print Head

To understand dot graphics you need to know a little about how your printer's print head works.

The print head has 24 pins. As the print head moves across the page, electrical impulses cause the pins to fire. Each time a pin fires, it strikes the inked ribbon and presses it against the paper producing a small dot. As the print head moves along, the pins fire time after time in different patterns forming letters, numbers, and symbols.

Because the dots overlap each other both horizontally and vertically in Letter Quality mode, it is difficult to see the individual dots. Instead, the letters and symbols seem to be made up of unbroken lines.

In order for the dots to overlap vertically, the pins in the print head are in more than one column, but the intelligence of the printer handles the timing of pin firings so that the effect is that of 24 pins arranged in a single vertical column.

## Dot patterns

The print head is able to print graphics, as well as text because graphic images are formed on the printer in about the same way that pictures in newspapers and magazines are printed. If you look



closely at a newspaper photograph, you will find that it is made up of thousands of small dots. Your printer also forms its images with patterns of dots, as many as 360 dots per inch horizontally and 360 dots per inch vertically. The images printed by this printer can, therefore, be as finely detailed as the ones at the beginning of this section.

### Twenty-four-pin graphics

The graphics mode that takes full advantage of this printer's print head is 24-pin graphics. This mode has five densities, but for simplicity this explanation deals with only one of them, triple-density.

Triple-density prints up to 180 dots per inch horizontally. As the print head moves across the paper, every 1/180th of an inch it must receive instructions about which of its 24 pins to fire. At each position it can fire any number of pins, from none to 24. This means that the printer must receive 24 bits of information for each column it prints. Because the printer uses 8-bit bytes of information in communicating with the computer, it needs three bytes of information for each position.

### Pin labels

To tell the printer which pins to fire in each column, you first divide each of the vertical columns into three sections of eight pins each and consider each section separately. Because there are 256 possible combinations of the eight pins in each section, you need a numbering system that allows you to use a single number to specify which of the 256 possible patterns you want. This numbering system is shown below.

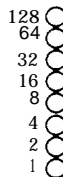

To fire any one pin, you send its number to the printer. To fire more than one pin at the same time, add up the numbers of the pins and send the total. Using these labels for the pins, you fire the top pin by sending 128. To fire the bottom pin, you send 1. If you want to fire only the top and bottom pins, you simply add 128 and 1, and send 129.

By adding the appropriate label numbers together, you can fire any combination of pins. Below are three examples of how to calculate the number that will fire a particular pattern of pins.

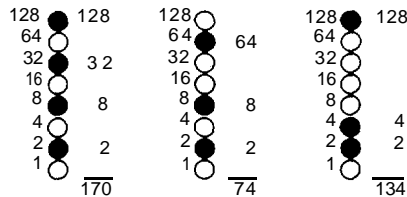

With this numbering system, any combination of the eight pins adds up to a decimal number between 0 and 255, and no numbers are duplicated.

Because there are 24 pins in each column, you must make a calculation for each of the three sections in each column. As you can see, this method of planning and printing dot graphics requires considerable calculation. Because triple-density uses 180 columns per inch, printing a single line of triple-density graphics only one inch long requires 540 numbers. Fortunately, commercial graphics software is available to do these calculations for you.

Before you can put these numbers into a graphics program, however, you need to know the format of the graphics command.

## The Graphics Command

The graphics mode command is quite different from the other commands used by the printer. For most of the other printer modes, such as emphasized and double-width, one ESC code turns the mode on and another turns it off. For graphics, the command is more complicated because the code that turns on a graphics mode also specifies how many columns it will use. After the printer receives this code, it interprets the numbers that follow as pin patterns and prints them on the paper.

Your printer has one command that allows you to use any of the 11 graphics options. The format of the command is:

ESC\* *m n1 n2 data*

In this command, *m* selects the graphics option and *n1* and *n2* specify the number of columns to reserve for graphics. The available graphics options are listed below.

Option	Pins	<i>m</i>	Horiz. density dots/in.
Single-density	8	0	6 0
Double-density	8	1	1 2 0
High-speed double-density*	8	2	1 2 0
Quadruple-density*	3	3	2 4 0
CRT I	8	4	8 0
CRT II	8	4	9 0
Single-density	2 4	3 2	6 0
Double-density	2 4	3 3	1 2 0
CRT III	2 4	3 8	9 0
Triple-density	2 4	3 9	1 8 0
Hex-density*	2 4	4 0	3 6 0

\* Adjacent dots cannot be printed in this mode.

## Column Reservation Numbers

The graphics command requires more than one number to specify how many columns to reserve because one line can use thousands of columns, but the printer does not use numbers larger than 255 in decimal. Therefore the graphics mode command uses two numbers,  $n1$  and  $n2$ , for reserving columns.

To find  $n1$  and  $n2$ , divide the total number of columns by 256. The result is  $n2$ ; the remainder is  $n1$ . Because the command is set up for two numbers, you must supply two even if you need only one. When you need fewer than 256 columns, just make  $n1$  the number of columns you are reserving and make  $n2$  a zero.

For example, if you wish to send 1632 columns of graphics data,  $n1$  should be 96 and  $n2$  should be 6 because  $1632 = 96 + (6 \times 256)$ .

The printer interprets the number of bytes specified by  $n1$  and  $n2$  as graphics data, no matter what codes they are. This means that you must be sure to supply enough bytes of graphics data or the printer stops and waits for more data and seems to be locked. If, on the other hand, you supply too much graphics data, the excess is interpreted and printed as regular text.

## A Simple Graphics Program

This first program is just a simple example to show you how the graphics command, column reservation numbers, and data can be used in a BASIC program.

Type in and run the following program. Be especially careful to include both semicolons. The program produces the printout you see below.

```
10 WIDTH "LPT1:",255
20 LPRINT CHR$(27)"*"CHR$(32)CHR$(40)CHR$(0);
30 FOR X=1 TO 120
40 LPRINT CHR$(170);
50 NEXT X
```



Line 20 selects single-density 24-pin graphics mode (mode 32) and also reserves 40 columns for graphics. Because 24-pin graphics requires three bytes of data for each column, line 30 begins a loop to supply 120 bytes of data. Line 40 contains the number 170, which produces the first pin pattern shown in the section on pin labels, and line 50 ends the loop.

## Designing Your Own Graphics

With what you know now, you can use the simplest application of graphics—calculating by hand the data to print the graphic image. While this method is the most tedious, it helps you understand dot graphics. It is also useful for small graphic elements that are used many times.

The illustration below shows how you can use a grid on paper to plan where you want dots to be printed. This grid is for a single line of graphics 42 columns long. Because each line of 24-pin graphics is approximately 1/8th of an inch high and because triple-density graphics prints 180 dots per inch horizontally, a design planned on this grid will be about 1/8th of an inch high and less than 1/4th of an inch wide.

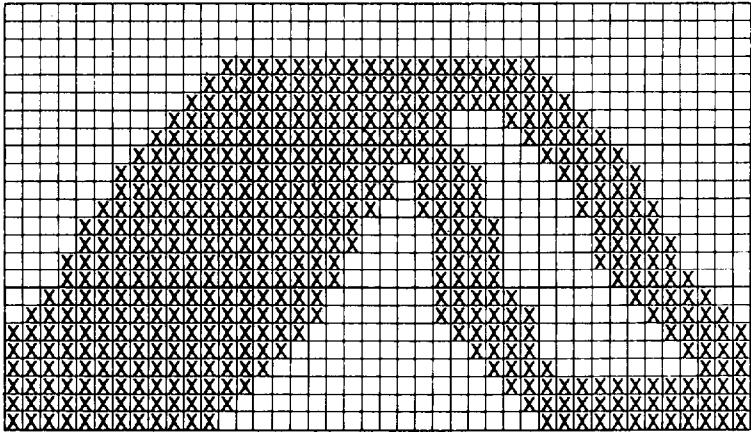

The actual pattern that the printer prints on the paper is, of course, made up of dots that overlap each other both vertically and horizontally. The reason the planning grid uses an x for each dot is that using an accurate representation of the dots makes calculating the data numbers difficult because they cover each other. Therefore, remember that each x represents the center of a dot, and the dots actually overlap.

Write the assigned values of the pins next to your design, then total the values for each column of dots. These totals are the values that you send to the printer as graphics data to print the design.

Below is the same grid divided into three sections to make the data calculation easier. At the bottom of each section of each column is the total of the pin numbers for that section. This gives you the total of 126 data numbers necessary to print this small figure.

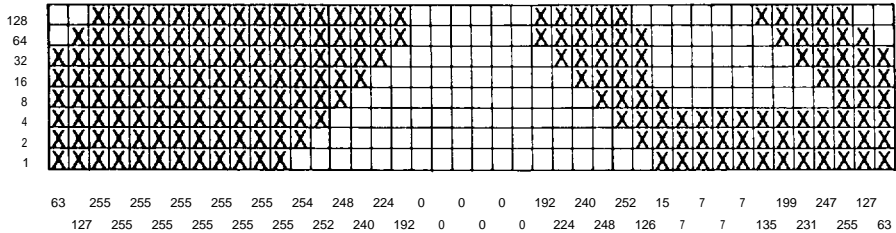
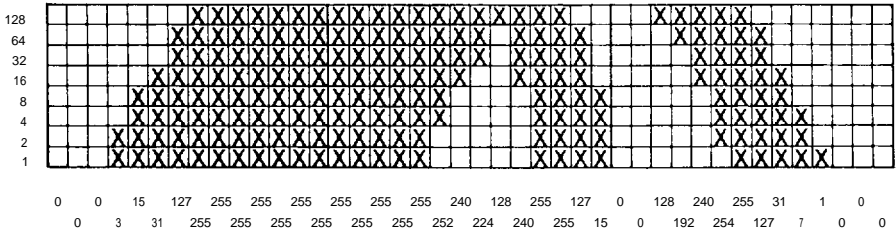
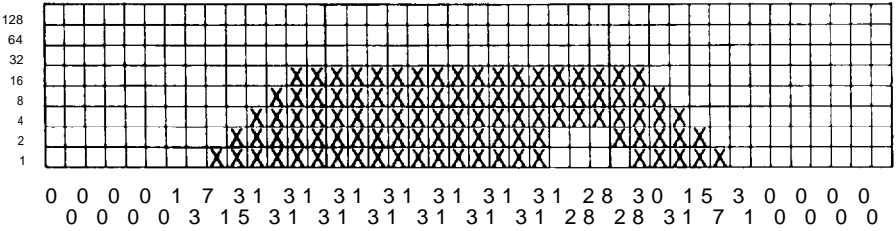

The BASIC program that prints the above design is shown on the next page. Note that the data numbers in lines 80 through 140 are the same numbers that are at the bottom of each section in the last illustration. The WIDTH statement in line 10 is for IBM PC BASIC; the WIDTH statement format may be different for your system.

```

10 WIDTH "LPT1:",255
20 LPRINT CHR$(27)**"CHR$(39)CHR$(42)CHR$(0);
30 FOR X=1 TO 126
40 READ IN
50 LPRINT CHR$(N);
60 NEXT X
70 LPRINT
60 DATA 0,0,63,0,0,127,0,0,255,0,3,255,0,15,255,0,31,255
90 DATA 0,127,255,0,255,255,1,255,255,3,255,255,7,255,255,15),
    255,255
100 DATA 31,255,254,31,255,252,31,255,240,31,255,
    224,31,255,192
110 DATA 31,255,0,31,252,0,31,240,0,31,224,0,31,120,0,31,240,0
120 DATA 31,255,192,28,255,224,28,127,240,28,15,248,30,0,252,
    31,0,126
130 DATA 15,128,15,7,192,7,3,240,7,1,254,7,0,255,7,0,127,135
140 DATA 0,31,199,0,7,231,0,1,247,0,0,255,0,0,127,0,0,63

```

In this program, line 20 assigns the graphics option (24-pin triple-density) with code 39. Code 42 sets the number of pin columns at 42. Lines 80 through 140 contain 126 bytes of data (42-pin columns x 3 bytes) for each pin column. Lines 30 through 60 print the design that you see below.



Notice that the dots overlap quite a bit. This design was printed using the triple-density, 24-pin graphics option because the density is the same (180 dots per inch) in both directions.

Adding the following lines to the preceding program causes the pattern to print 10 times in a row as shown below.

```

15 FOR C=1 TO 10; RESTORE
65 NEXT C

```





## User-defined Characters

With this printer, it is possible to define and print characters of your own design. You can design an entirely new alphabet or typeface, create special characters for use as mathematical or scientific symbols, or create graphic patterns with user-defined characters to serve as building blocks for larger designs.

Below, you can see samples of typefaces created with the user-defined character function.

**ABCDEFGHIJKLMN OPQRSTUVWXYZ**  
**ABCDEF6HIJKLMN OPQRSTUVWXYZ**

**Note:** To use user-defined characters, you must turn DIP switch 2-5 off.

You can make the task of defining characters easier by using a commercial software program that assists you in creating characters or simply supplies you with sets of characters already created. Also, some popular software programs make use of the printer's user-defined character function to enhance printouts. (These characters are called download characters in some programs.)

The standard ASCII characters are stored in the printer's Read Only Memory (ROM), and the user-defined characters are stored in the printer's Random Access Memory (RAM).

## Designing Your Characters

User-defined characters are like dot graphics because you send the printer precise instructions on where you want each dot printed. In fact, planning a user-defined character is like planning a small dot graphics pattern.

## Design grids

To design a character you use a grid that is 24 dots high—one dot for each pin on the printer's print head. The width of the character matrix depends on the character set in use. For draft characters, the grid is nine dots wide, for Letter Quality it is 29 dots wide, and for proportional characters it is 37 dots wide. The dots for both Letter Quality and proportional characters are spaced more closely together than those for draft characters.

The illustrations below show the two design grids. The line at the side, labeled cap height, indicates the top of a standard capital letter. The line labeled baseline indicates the baseline for all letters except those with descenders (the bottom parts of such letters as j and y). The bottom row is usually left blank because it is needed for underlining.

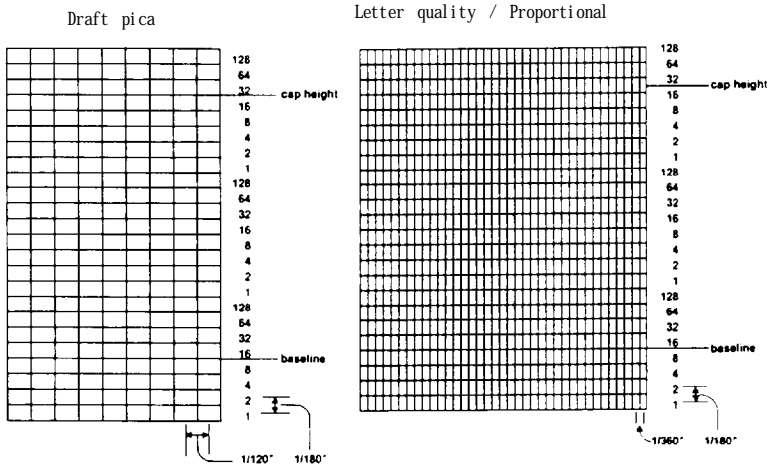

The grid on the right side can be used for either Letter Quality or proportional characters. For Letter Quality you do not use all the columns.

There is one restriction in designing characters. Dots in the same row may not print in adjacent columns. This means that there must be an empty dot position both to the left and right of each dot that prints. This is true in draft, Letter Quality, and proportional mode.

## Defining Your Characters

The first step in defining characters is to place the dots on a grid just as you want them to print. The examples shown here, like the ones in the graphics section, use an x to represent each dot.

In the illustration below, you see a draft grid with a simple user-defined character planned on it.

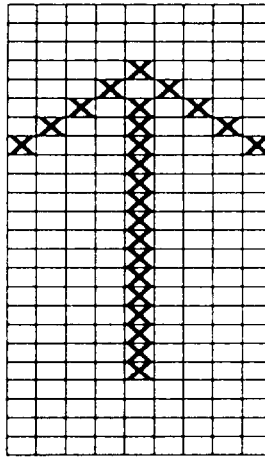

Now you translate the dot pattern you've created on paper to a numeric format so you can send the data to your printer. Every dot has an assigned value. Each vertical column (which has a maximum of 24 dots) is first divided into three groups of eight dots. Each group of eight dots is represented by one byte, which consists of eight bits. Hence, one bit represents one dot.

## Data numbers

The bits within each byte have values of 1,2,4,8,16,32,64, and 128. In the vertical column of dots, the bits are arranged so that the most significant bit (with a value of 128) is at the top of the column and the least significant bit (with a value of 1) is at the bottom.

The next illustration shows how to use this method to calculate the data numbers for the character in this example. On the left side of the figure, the data numbers are calculated for the middle column. The value of each byte is calculated by adding the values of the rows in which dots appear. The right side of the figure shows the whole character with the three data numbers for each column indicated at the bottom.

This manual uses decimal numbers because the program examples are written in BASIC and everyone is familiar with decimals. The data you send to your printer, however, must be in the form (binary, decimal, hexadecimal) that you can use with your programming language.

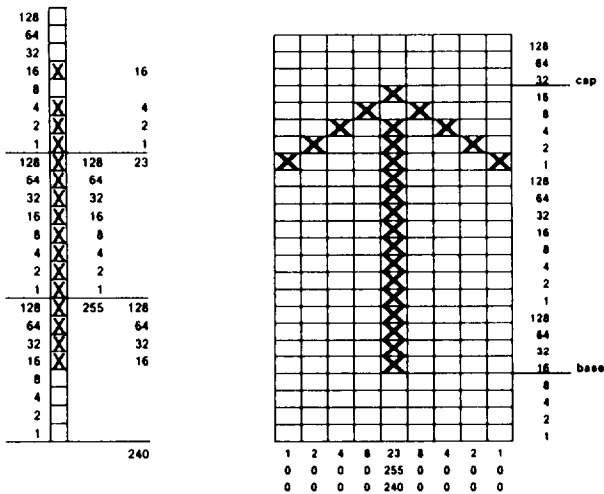

You have seen how to design a character by placing dots on a grid and translating the dots to decimal equivalents. The last step in defining a character is sending this information to your printer.

## **Sending Information to Your Printer**

The printer loads characters in the print style (Letter Quality, draft, or proportional) that the printer is currently using. It also records whether italic, superscript, or subscript is turned on. This means that if you want to print a character in italics, for example, you must have the italic mode turned on when you define the character.

The command your printer uses to define characters is one of the most complex in its repertoire. The format of the command is this:

ESC & 0 *n1 n2 d0 d1 d2* data

The ESC & is simple enough. The 0 allows for future enhancements. At this time, it is always ASCII 0.

You can define many characters with a single command. The values *n1* and *n2* are the ASCII codes of the first and last characters you are defining. If you are defining only one character, *n1* and *n2* are the same. You can use any codes between decimal 32 and 127 for *n1* and *n2*, but it is best not to define decimal 32, which is the code for a space. Also, you can use letters in quotation marks instead of ASCII codes for *n1* and *n2*.

**Note:** Because user-defined characters require additional memory, you must set DIP switch 2-5 to 1 KB (off) before downloading these characters.

An example will show how to specify  $n1$  and  $n2$ . For instance, if you wanted to redefine the characters A through Z,  $n1$  would be ASCII A (or decimal code 65) and  $n2$  would be ASCII Z (or decimal code 90). So the command ESC & 0 AZ (followed by the appropriate data) would replace the entire alphabet of capital letters.

Following the specification of the range of characters to be defined in this command are three data bytes,  $d0$ ,  $d1$ , and  $d2$ , that specify the width of the character and the space around it. The left space (in dot columns) is specified by  $d0$ , and the right space is specified by  $d2$ . The second byte,  $d1$ , specifies the number of columns of dots that are printed to make up the character. By varying the width of the character and the spaces around it, you can create proportional width characters that print at draft speed. The table below shows the maximum values for these bytes.

Mode	$d1$	$d0+d1+d2$
Draft	91	12
Letter Quality 10 cpi	29	36
Letter Quality 12 cpi	23	30
Proportional	37	42

The last part of the command to define your characters is the actual data that defines the dot patterns for each character. Because it takes three bytes to specify all the dots in one vertical column, your printer expects  $d1 \times 3$  bytes of data to follow  $d2$ .

This example of a character definition program should make this clear:

```
10 LPRINT CHR$(27)"X0"  
20 LPRINT CHR$(27)"&"CHR$(0);  
30 LPRINT "@@";  
40 LPRINT CHR$(1)CHR$(9)CHR$(1);  
50 FOR I=1 TO 27  
60 READ A: LPRINT CHR$(A);  
70 NEXT I  
80 LPRINT "#####"  
90 LPRINT CHR$(27)"%"CHR$(1);  
100 LPRINT "#####"  
110 LPRINT CHR$(27)"%"CHR$(0);  
120 LPRINT "#####"  
130 END  
140 DATA 1,0,0,2,0,0,4,0,0  
150 DATA 8,0,0,23,255,240,8,0,0  
160 DATA 4,0,0,2,0,0,1,0,0
```

In line 10, the ESC *x0* command selects draft printing.

The actual character definition starts in line 20. The two @ signs in line 30 represent *n1* and *n2*, the range of characters being defined (in this case, a range of 1). Line 40 contains *d0*, *d1*, and *d2*.

The information about the actual character design (which is contained in the DATA statements at the end of the program) is sent to the printer in the loop between lines 50 and 70.

**Note:** When defining Letter Quality or proportional characters, put a WIDTH statement in your program to prevent carriage return and line feed codes from interfering with your definitions.

## Printing User-defined Characters

If you entered the previous program example, you defined an arrow and placed it in the RAM location for ASCII code 64 (replacing the @ sign). You can now print out a three-line sample of your work. The first and third lines (printed by lines 80 and 120) print the normal @ sign. The second line (printed by line 100) prints out the arrow that you defined.

Run the program to see the printout below.

```
@@@@@@  
↑↑↑↑↑  
@@@@@
```

As you can see, both sets of characters (the @ from the original characters in ROM that the printer normally uses and the alternative character you defined) remain in the printer available for your use. The command to switch between the two sets is used in line 90 and 110. It is:

ESC % *n*

If *n* is equal to 0, the normal ROM character set is selected (this is the default). If *n* is equal to 1, the user-defined character set is selected. If you select the user-defined character set before you have defined any characters, the command is ignored and the ROM characters remain in use.

You may switch between character sets at any time--even in the middle of a line. To try this, place semicolons at the end of lines 80 and 100 in the program example.



## Copying ROM Characters to RAM

**After** running the program, if you select the user-defined character set and try to print other characters, the only one that will print is your arrow. Because no other characters are in the printer's user-defined RAM, there is nothing else to print. Other characters sent to the printer do not even print as spaces; it's as if they were not sent at all.

In many cases, you will want to redefine only a few of the characters to suit your needs—the rest of the alphabet will work fine as it is. As you have seen, it is possible to switch back and forth, at will, between the normal character set and your user-defined character set. It is, however, rather inconvenient.

Therefore, your printer has a command that allows you to copy all of the standard characters from ROM to the user-defined character set.

The command format is as follows, where the value of  $n$  represents the font family:

Esc:  $0\ n\ 0$

Note: This command cancels any user-defined characters you have already created. You must send this command to the printer before you define characters.

If you use this command at the beginning of a program, then define your special characters and select the user-defined set, you can print with the user-defined set as your normal character set. You never need to switch back and forth between sets.

## Letter Quality Characters

If you select Letter Quality printing with the ESC x1 command, you can design user-defined characters using up to 29 columns of the Letter Quality/Proportional grid. The dot columns are spaced closer together horizontally than draft dot columns (the horizontal dot spacing is 1/360th of an inch as opposed to 1/120th of an inch for draft characters).

## Proportional mode characters

Selecting the proportional character mode yields user-defined characters of the highest resolution. Characters can be designed using all 37 columns of the Letter Quality/Proportional grid.

Remember that in Letter Quality and proportional modes, as in draft mode, you cannot place dots in adjacent columns. There must be an empty dot position both to the left and right of each dot that prints.

## Superscripts and subscripts

You can also create superscript and subscript user-defined characters. Just as Letter Quality characters are defined when the Letter Quality mode is selected, superscript and subscript characters are created when either superscript or subscript is selected.

These characters can be used as either superscripts or subscripts. The characters are exactly the same; only their placement is different. The difference between these characters and regular characters is that superscript and subscript characters are smaller. They are a maximum of 16 dots high. Their maximum width in dot columns is shown in the table below.

Mode	$d\ 1$	$d\ 0 + d\ 1 + d\ 2$
Draft	7	12
Letter Quality	23	36
Proportional	23	42

Because superscript and subscript characters are smaller, when you define them you only need two bytes of data for each vertical row of dots. Design grids for these characters are shown in the figure below.

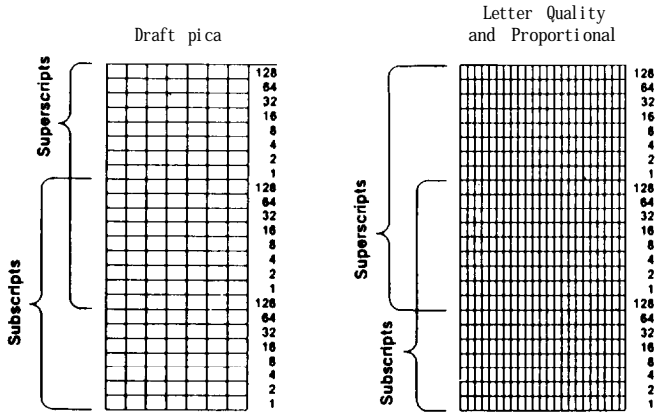

## Mixing Print Styles

Each of the three user-defined character modes (draft, Letter Quality, and proportional) can be used in combination with most of your printer's various print styles. For instance, emphasized mode works with user-defined characters. The characters you design are enhanced to give this printing effect.

Mixing the three types of user-defined character sets is not possible. For example, if you select draft and define some characters, then select proportional and define some more, the first draft character definitions are deleted. Only one type of character definition may be stored in RAM at any time.

If you define characters in one mode, then switch to another mode and select the user-defined character set, the command is ignored and nothing is printed. The user-defined character definitions, however, remain unaffected. If you switch back to the mode in which they were defined, you can then select and print them.

**Keep in mind that user-defined characters are stored in RAM, which is not permanent memory. When the printer power is turned off or the printer is initialized with the  $\overline{\text{INIT}}$  signal, the user-defined characters are lost. (Some computers do this each time BASIC is loaded.)**

# Chapter 5

## Using the Printer Options

The Cut Sheet Feeder .....	5-2
Installation .....	5-2
Paper Handling .....	5-6
Testing the Printer in the Cut Sheet Feeder Mode .....	5-9
Operating the Cut Sheet Feeder .....	5-11
Switching Between the Cut Sheet Feeder and PushTractor .....	5-15
Removing the Cut Sheet Feeder .....	5-22
The Pull Tractor .....	5-24
Installation .....	5-24
Paper Handling .....	5-27
Removing the Pull Tractor. ....	5-33
The Interface Boards .....	5-37
Choosing an Interface. ....	5-37
Compatible Interfaces. ....	5-38
Installation .....	5-38
#8143 New Serial Interface. ....	5-46



# The Cut Sheet Feeder

The optional cut sheet feeder (C806122/C806242) makes it possible to handle single-sheet paper more easily and more efficiently. Up to 150 sheets of standard bond paper can be fed automatically into the printer without reloading.

## Installation

1. Assemble the cut sheet feeder by following the instructions provided in its accompanying manual.

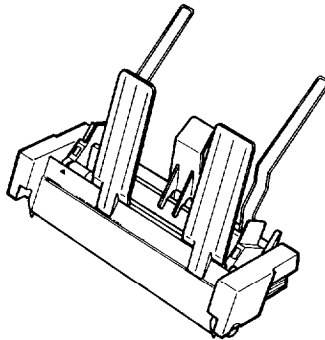

2. Make sure that the printer is turned off. Then remove the paper guide and printer cover.

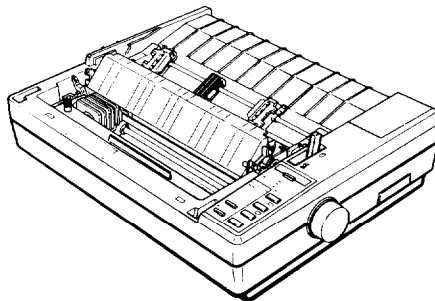

3. Separate the clear plastic part of the printer cover from the printer cover by pressing on the tabs on each side.

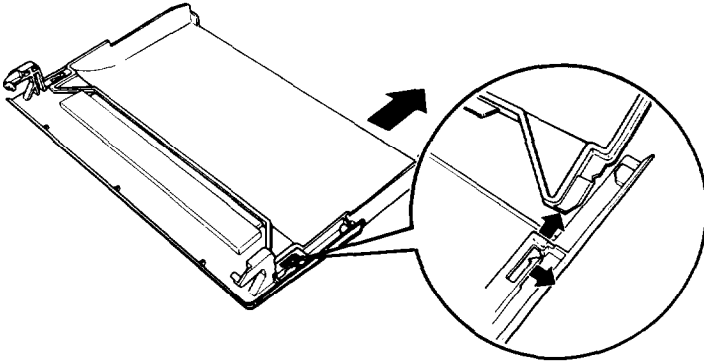

4. Attach the clear plastic part included with the cut sheet feeder to the printer cover.

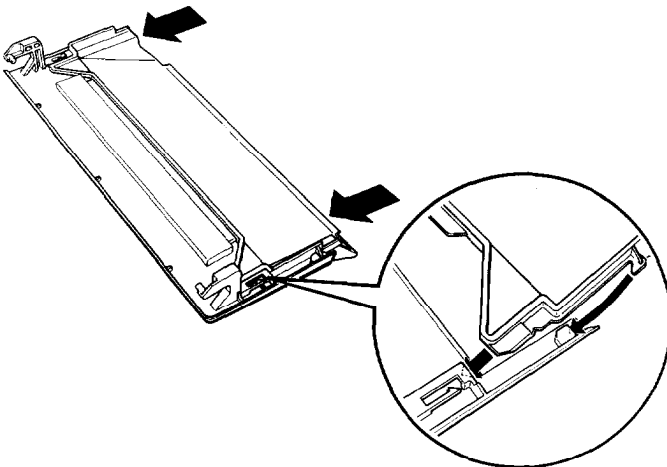

5. Make sure that the paper release lever is pushed all the way to the back.

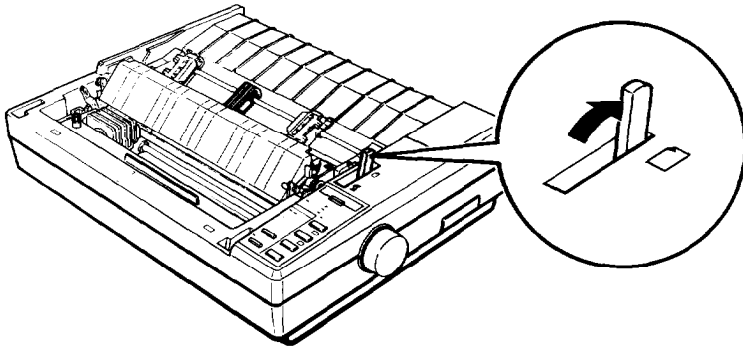

6. Tilt the cut sheet feeder slightly forward to fit the notches at the base of the unit over the black pins inside the printer. Tilt the feeder back until it rests on top of the printer.

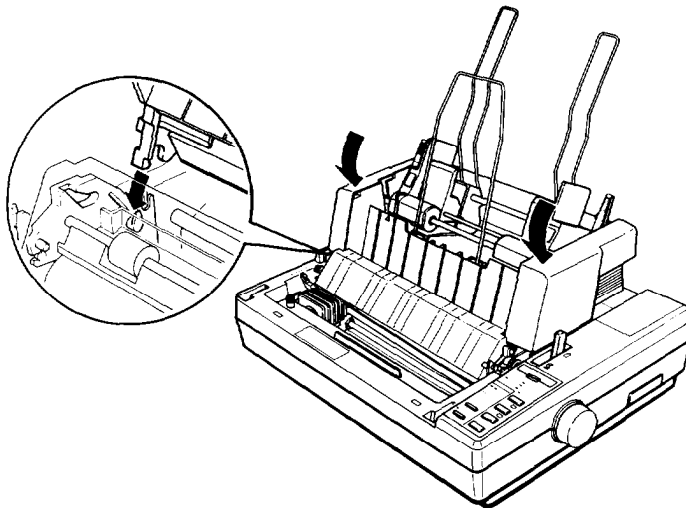



7. Attach the printer cover.

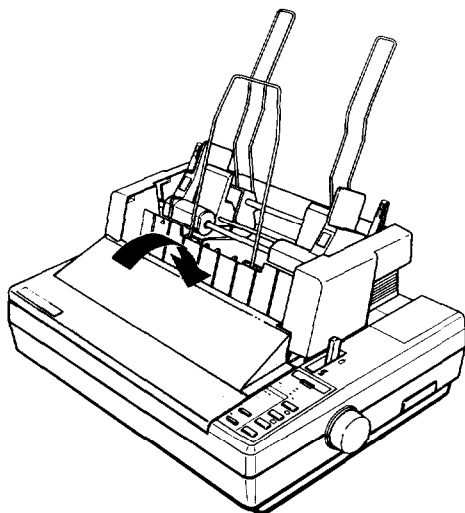

8. Turn on the cut sheet feeder mode by setting DIP switch 1-8 to on.

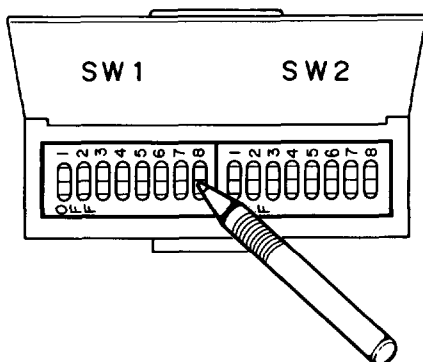

9. Turn on the printer.

## Paper Handling

1. Make sure that the cut sheet feeder mode is turned on with DIP switch 1-8.
2. Pull the paper set levers all the way forward until the paper supports retract and lock open to allow for paper loading.

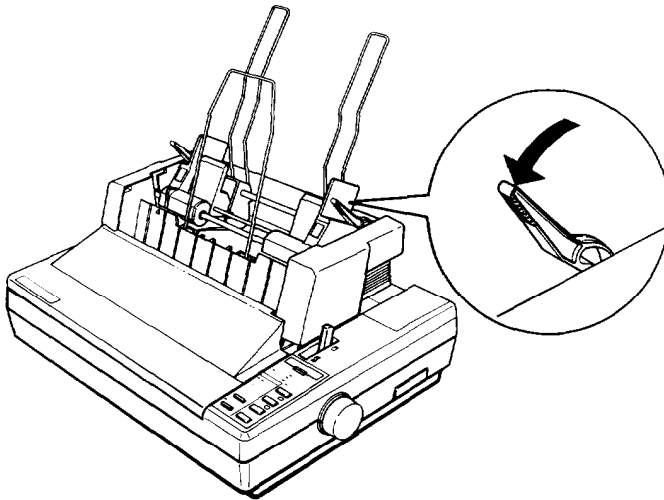

- Slide the left paper guide to where the fin on the edge guide aligns with the arrow on the panel. Next, slide the right paper guide so that it roughly matches the width of your paper.

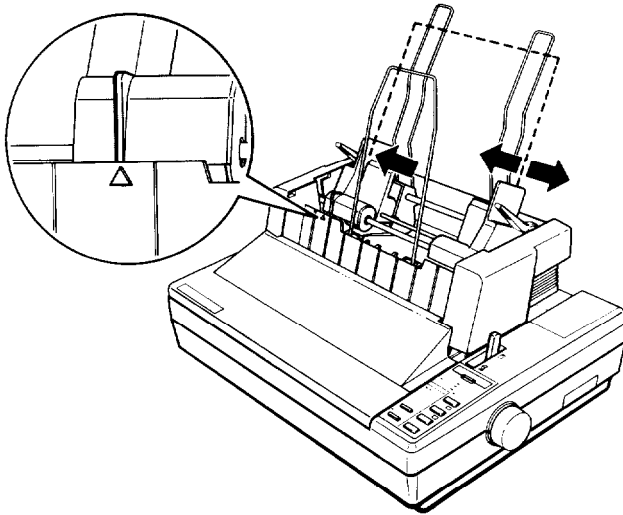

- Take a stack of paper and fan it as shown. This keeps the paper from sticking and ensures that only one sheet feeds at a time. Tap the side and bottom of the paper on a flat surface to even the stack.

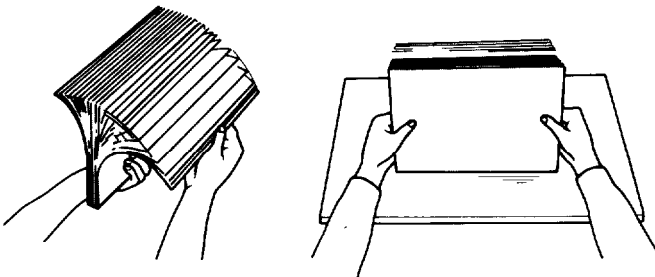

**Note:** For best results, use typewriter quality paper. If you plan to use paper with a **glossy or textured surface**, **test it** before using it to print documents. Do not use multi-part forms, carbon paper, envelopes, or labels in the cut sheet feeder.

5. Insert the stack of paper between the paper guides, aligning it with the left edge of the guide. Then adjust the right paper guide until the paper is held firmly, but not so tightly that it causes the paper to buckle. Make sure the paper can move up and down freely.

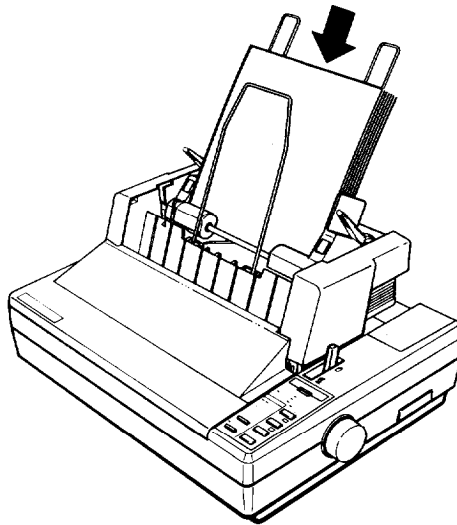

6. Push the paper set levers back until they click into place and clamp the paper against the guide rollers.

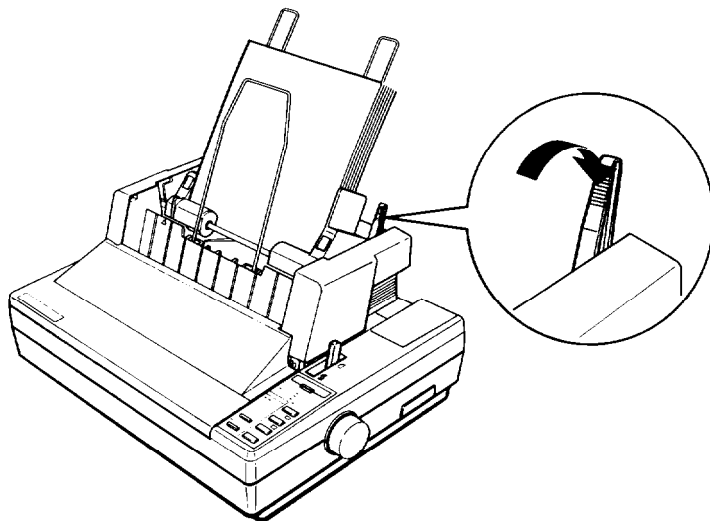

## Testing the Printer in the Cut Sheet Feeder Mode

When you perform the cut sheet feeder self test, the printer counts the number of lines on the page. As shown on the following page, the number of lines counted is printed out at the bottom of the first test page. This number is the default page-length setting. This setting, however, can be overridden by software commands.

Running the self test is the same as when the cut sheet feeder mode is off. The steps below are for a self test in draft mode.

**Note:** Run the self test using paper that is 8¼ inches (210 mm) wide on the standard width printer and 14 inches (360 mm) wide on the wide carriage printer.

1. Make sure that the printer is turned off and a stack of paper is in the bin. Check that the cut sheet feeder mode is selected and the paper release lever is set to the back position.

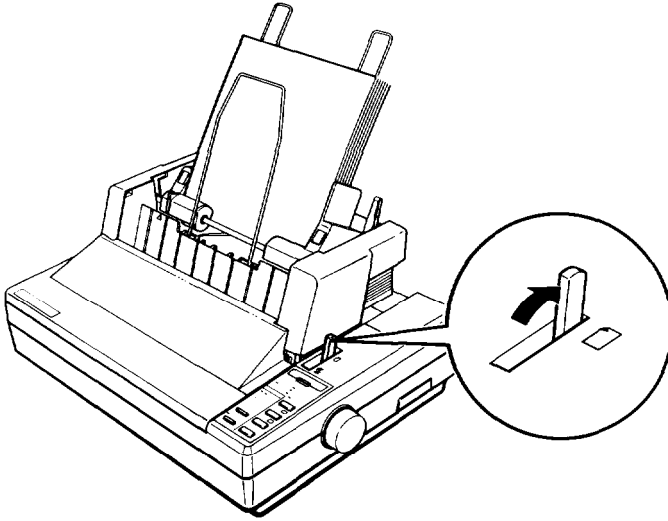

2. While holding down the **LINE FEED** button, turn on the printer. (For LQ mode, press the **FORM FEED** button instead of the **LINE FEED** button.)

A part of the printout of the fit sheet is shown below. The printout of the second sheet is similar to the original self test described in Chapter 1.

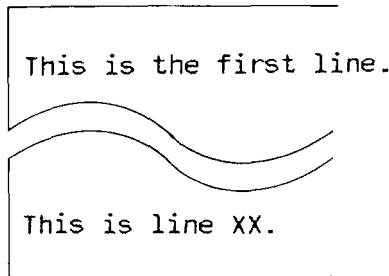

3. The self test continues until the paper runs out or until you press the **ON LINE** button. To stop the test, press the **ON LINE** button.

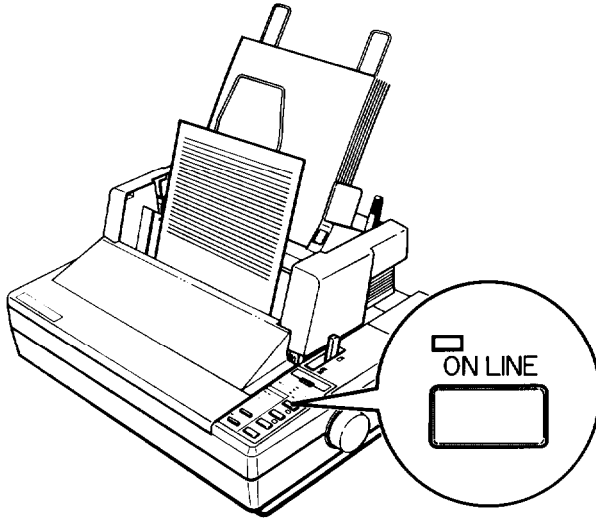

4. To end the self test **when** paper is loaded, press the **LOAD/EJECT** button to eject the paper. Then turn off the printer.

## Operating the Cut Sheet Feeder

After stacking paper in the cut sheet feeder, turn on the printer and make sure that the **ON LINE** light is on. When the printer is on line, a new sheet of paper loads automatically whenever a printable character or line feed command is sent to the printer.



**CAUTION:** If there is no paper in the cut sheet feeder, do not press the **FORM FEED** button or the **LOAD/EJECT** button, and do not send data to the printer.

## **Paper out condition**

When the printer is **on** line and receives print data from the computer, the first **sheet** loads automatically. Subsequent sheets load automatically as necessary.

- In the cut sheet feeder mode, the **PAPER OUT** light goes on while a sheet of paper is being fed, but the printer remains on line.
- When the specified paper bin is empty, the printer automatically goes off line, the **PAPER OUT** light goes on, and the beeper sounds. To resume printing, add more paper and press the **ON LINE** button.

**Note:** If you turn off your printer during the time the printer detects a paper out or paper jam condition, any data remaining in the printer's buffer is discarded.

## **Inserting single sheets**

Your cut sheet feeder also has a single-sheet loading feature. This feature is especially useful because it allows you to switch to a different type or size of paper (for one **sheet** only) without replacing the stack of paper in your cut sheet feeder.

1. Press the **ON LINE** button to set the printer off line.
2. Align the single sheet to be fed with the mark **on** the left paper guide. Then slide **the sheet** into the printer path until you feel resistance.



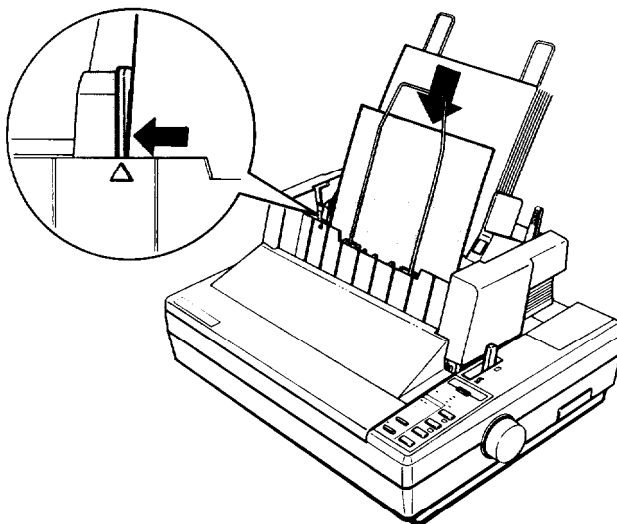

3. Press the LOAD/EJECT button to load the sheet.

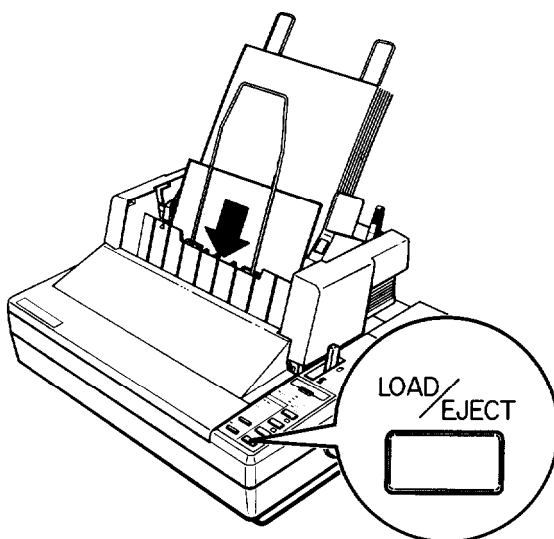

## Using the control panel

To operate the cut sheet feeder manually from the control panel when the printer is in the cut sheet feeder mode, first make sure that the printer is off line.

LINE FEED	When there is paper in the printer, press this button to feed the paper one line or hold it down to feed the paper continuously.
FORM FEED	When there is no paper in the printer, press this button to load paper from the cut sheet feeder. When there is paper in the printer, press this button to eject the sheet.
LOAD/EJECT	When there is no paper in the printer, press this button to load the paper from the cut sheet feeder. When there is paper in the printer, press this button to eject the sheet.

## Using software

The following commands cause the printer to eject the sheet in the printer without loading the next sheet.

FF:	Form feed
ESC EM R:	Ejects a sheet in the cut sheet feeder mode

**Note:** The ESC EM command is a software command used to control the operation of the cut sheet feeder. For more information about this command, see the Command Summary in Chapter 9.

If the paper reaches the bottom of the print area when any of the following line feed commands is used, the sheet in the printer is automatically ejected and the next sheet is loaded.

- LF: Line feed; advances the paper one line
- VT: Vertical tab; advances the paper to the next vertical tab position
- ESC J: Line feed; advances the paper n/180th of an inch

Software is not effective while the printer is off line. Make sure that the printer is on line if you wish to control the cut sheet feeder using software commands.

### Switching Between the Cut Sheet Feeder and Push Tractor

The printer lets you switch easily between the cut sheet feeder and tractor-feeding systems without having to remove either the feeder or the continuous paper supply.

1. Make sure the continuous paper is already loaded and in the standby position. Next, press the **ON LINE** button to set the printer off line.

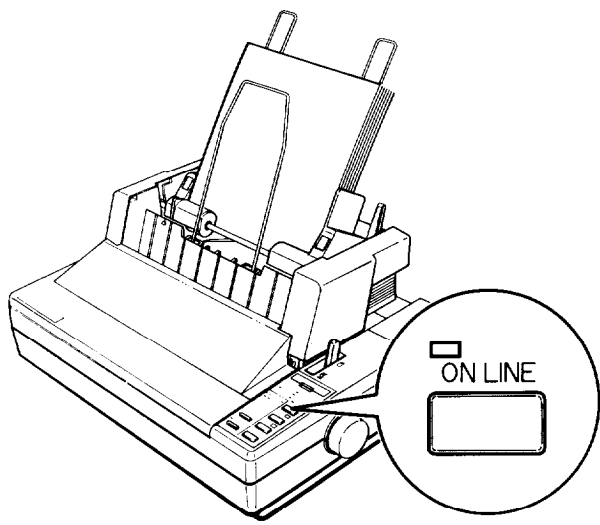

2. If any single sheets are still in the printer, press the **LOAD/EJECT** button to eject the paper.

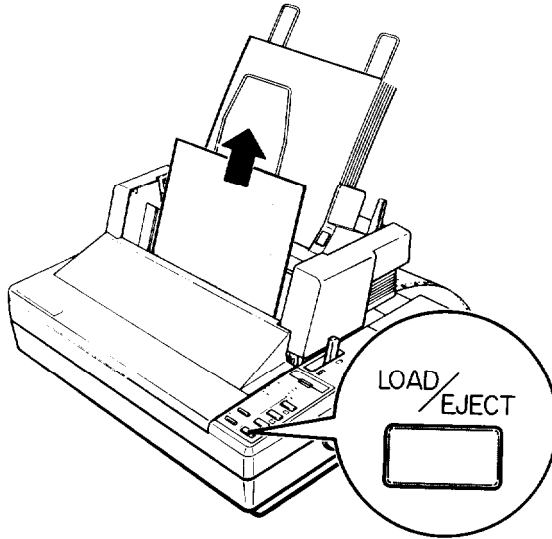

3. Pull the paper release lever forward to the continuous paper position. You do **not** need to change the DIP switch 1-8 setting.

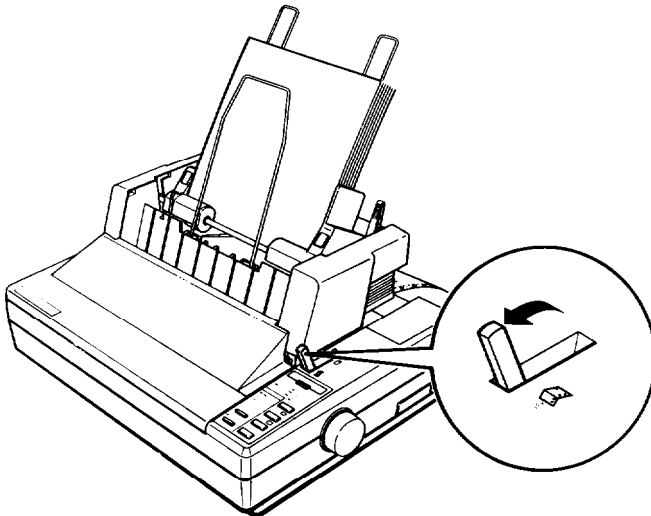

On the wide carriage printer, set the paper release lever to the center continuous paper position.

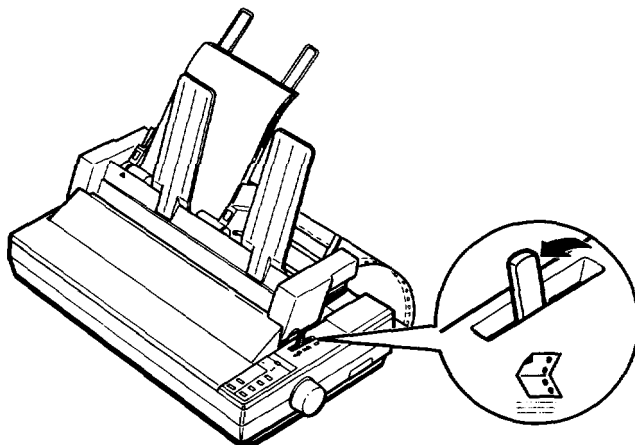

4. Press the **LOAD/EJECT** button to load continuous paper.

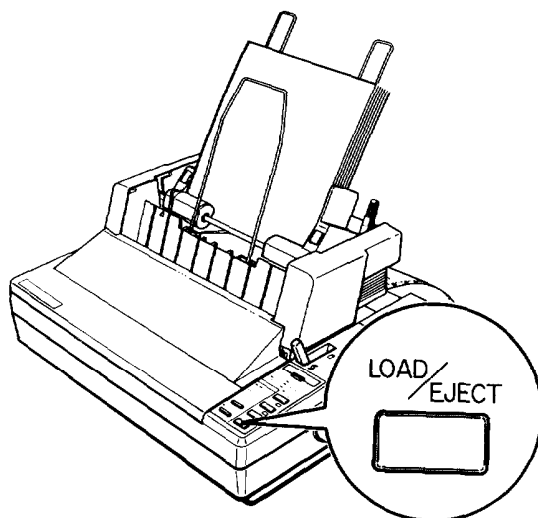

5. Press the **ON LINE** button to set the printer on line so that it can accept data.
6. After the first printed page passes the printer cover edge, fold at the perforation so the page lies on the printer cover.

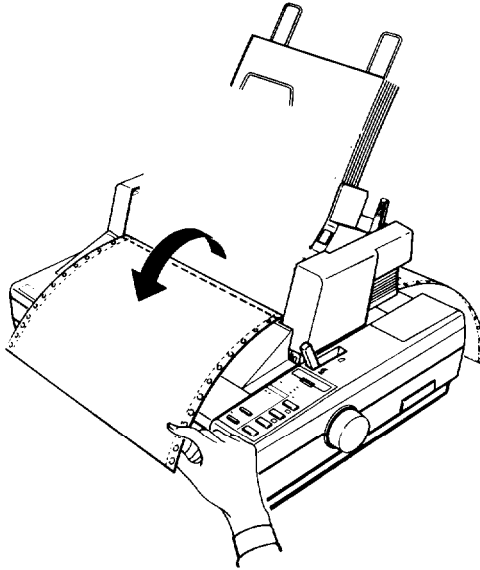

**Note:** It is important to keep the printed continuous paper aligned with the tractor so that the paper feeds smoothly into the printer.

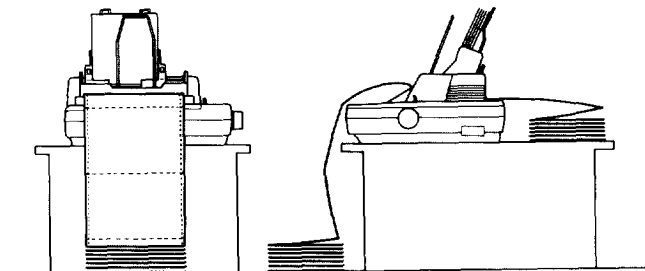

### Switching back to the cut sheet feeder

It is easy to switch back to using the cut sheet feeder.

1. Press the **ON LINE** button to set the printer off line.

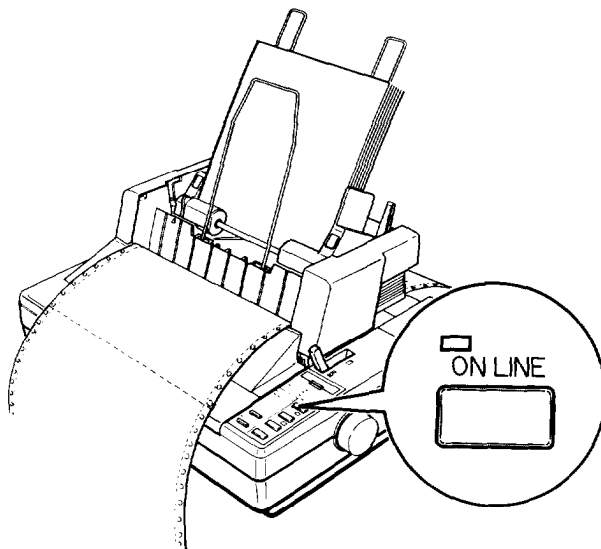

2. Press the **FORM FEED** button to eject any printed continuous paper. Tear off all printed sheets.

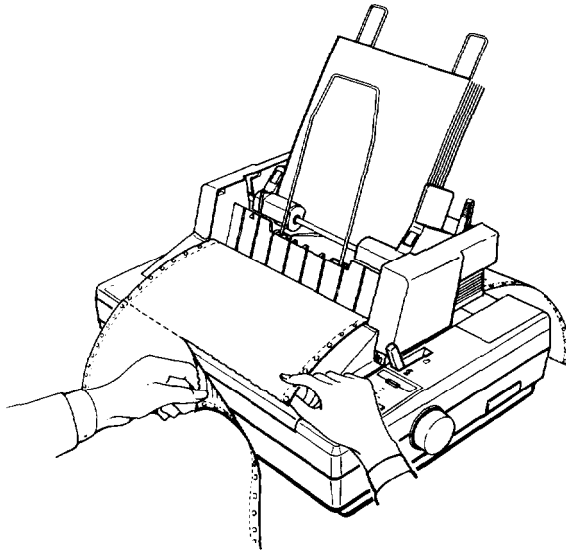

**CAUTION:** To feed printed continuous paper forward, use the **FORM FEED** button only. Never press the **LOAD/EJECT** button; this will feed the continuous paper backward.



3. Press the LOAD/EJECT button until you feed the continuous paper backward out of the paper path and into the standby position.

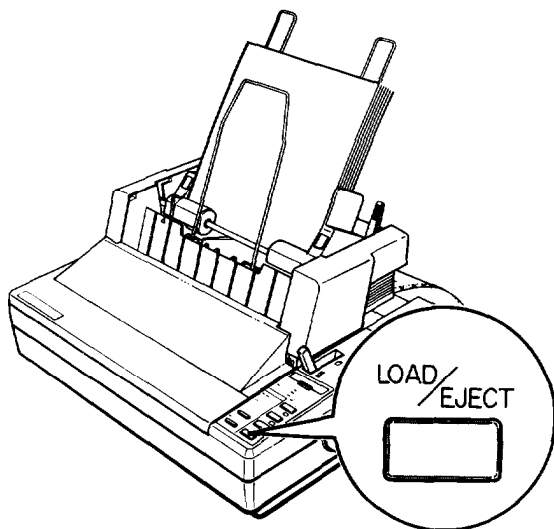

**CAUTION:** Never press the LOAD/EJECT button more than twice. This may cause a paper jam.

4. Push the paper release lever back to the single sheet position.

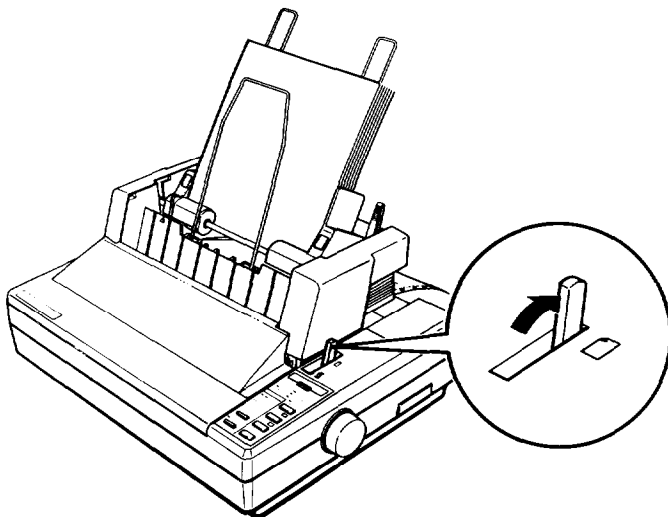

5. Press the ON LINE button to set the printer on line.

### **Removing the Cut Sheet Feeder**

1. Turn off the printer and remove any paper remaining in the bin and printer.
2. Remove the printer cover.

3. Tilt the cut sheet feeder back. Release its notches from the printer's pins, and then lift up and remove the cut sheet feeder.

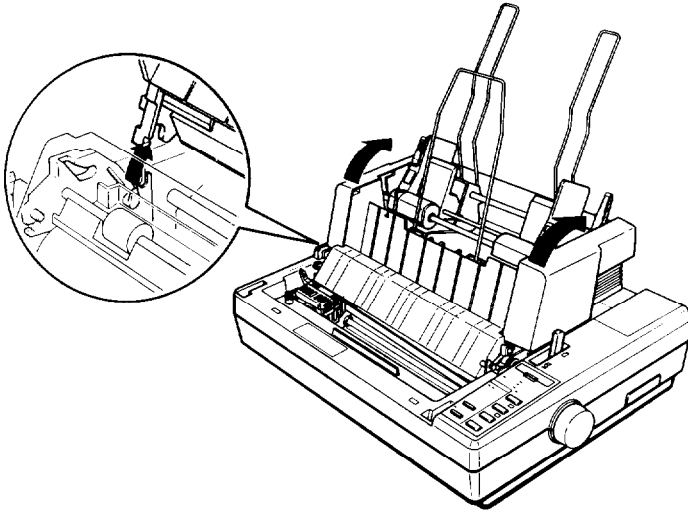

4. Set DIP switch 1-8 to off (to turn off the cut sheet feeder mode).
5. Replace the clear plastic part of the cut sheet feeder cover with the clear plastic part that was originally on the printer cover.

Removal of the cut sheet feeder is now completed. Be sure to store the removed cut sheet feeder in its original box and packing materials.

## The Pull Tractor

The optional pull tractor (C800062/C800142) provides optimum continuous paper handling. The pull tractor is especially useful with continuous multi-part forms and labels. For best results, use the pull tractor along with the built-in push tractor as described in this section.

### Installation

1. Turn off the printer and remove the printer cover and paper guide.
2. On the standard width printer, remove the paper tension unit cover.

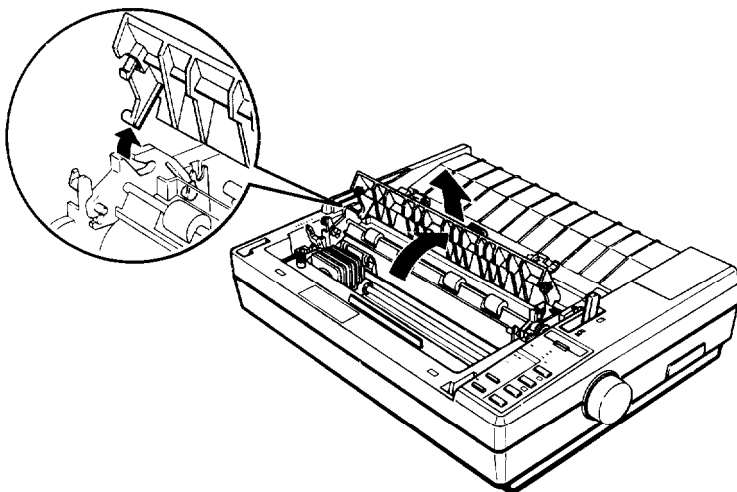

On the wide carriage printer, you remove the paper tension unit.

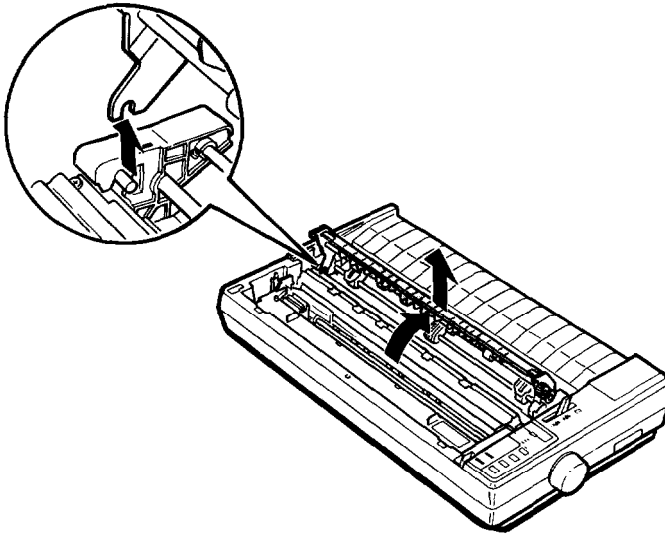

3. Fit the rear notches on the tractor over the rear mounting pins in the printer. Then tilt the tractor unit toward you until the front latches click in place over the black front mounting pins. Push down on the front latches to be sure they are firmly seated.

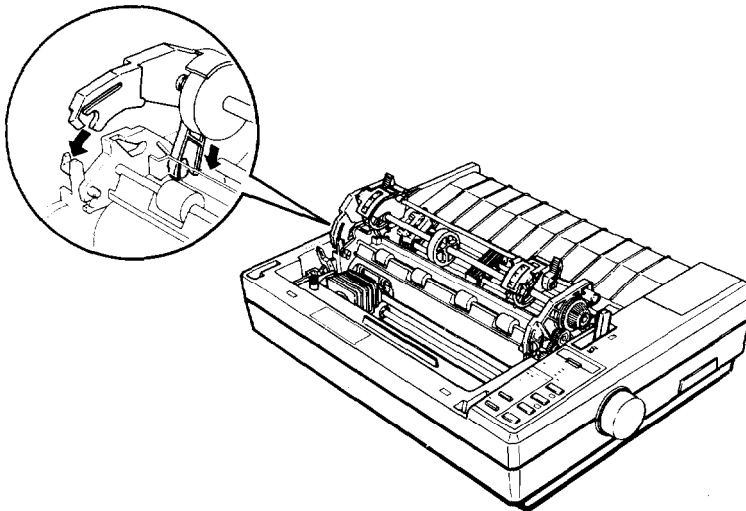

4. Pull the paper release lever forward to the continuous paper position.

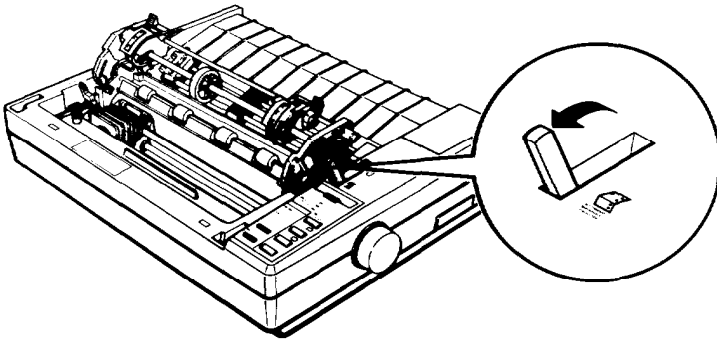

5. Set DIP switch 2-2 to off.

**Note:** You cannot use the short tear-off function with the pull tractor.

6. Turn on the printer.

## Paper Handling

1. Make sure that the printer is turned on and that the paper release lever is set forward to the continuous paper position.

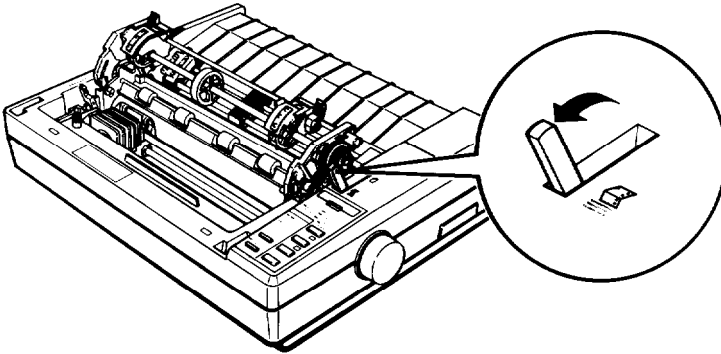

**Note:** For both the standard width printer and wide carriage printer, this is the forward continuous feed position.

2. Set the first three holes of the continuous paper onto the built-in push tractor as described in Chapter 2.
3. Press the LOAD/EJECT button to load the continuous paper; then press the FORM FEED button. This advances the paper one page so that you can fit the paper onto the pull tractor.

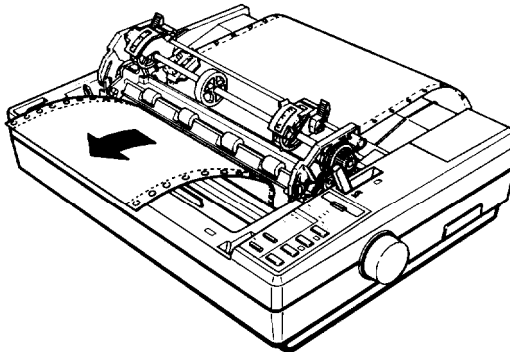

**Note:** After you press the FORM FEED button, be careful not to touch any of the buttons on the control panel until step 10.



**CAUTION:** Never use the platen knob while the printer is turned on. To adjust the loading position, use the micro-adjustment feature described in Chapter 3.

4. Open the sprocket covers of the pull tractor and pull the sprocket lock levers toward you to release them.

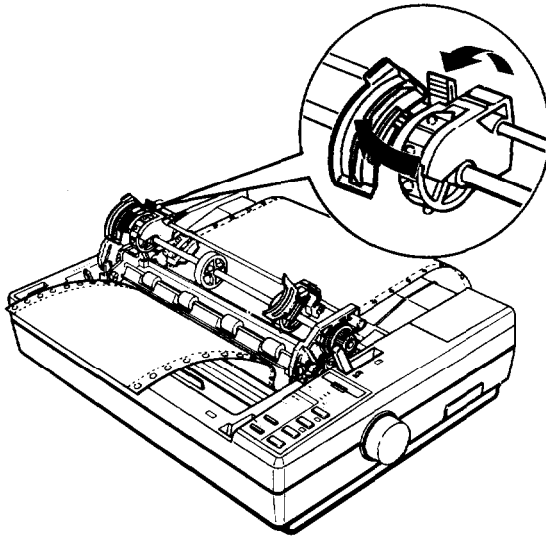



- Adjust the sprocket units to match the width of the paper. Then adjust the paper support so that it is **halfway between** the sprocket units.

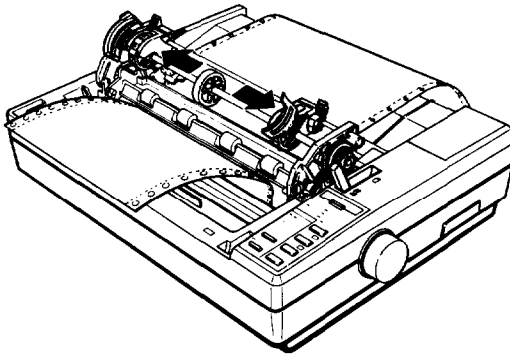

- Fit the holes in the paper over the tractor pins on the sprocket units and close the sprocket covers.

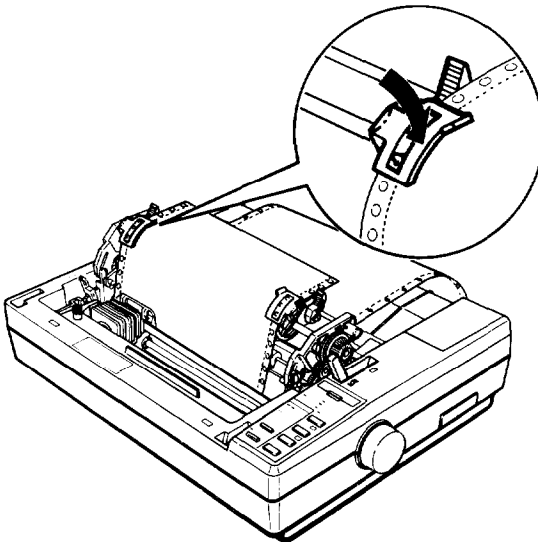

7. If the paper does not fit exactly onto the tractor pins or if the paper buckles, press in on the gray pull tractor knob and turn it in the desired direction until the paper fits properly.

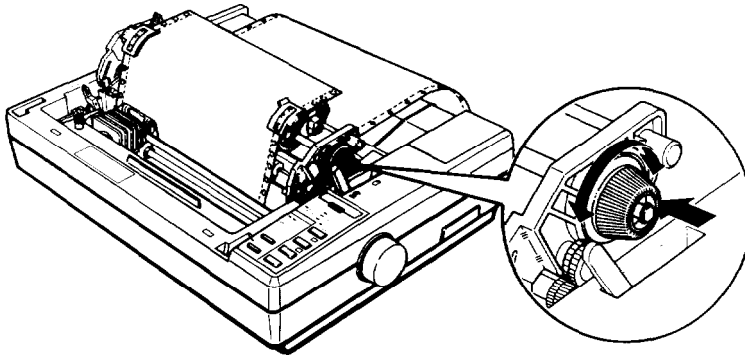

8. See that the paper is not crooked or wrinkled and lock the sprocket units in place.

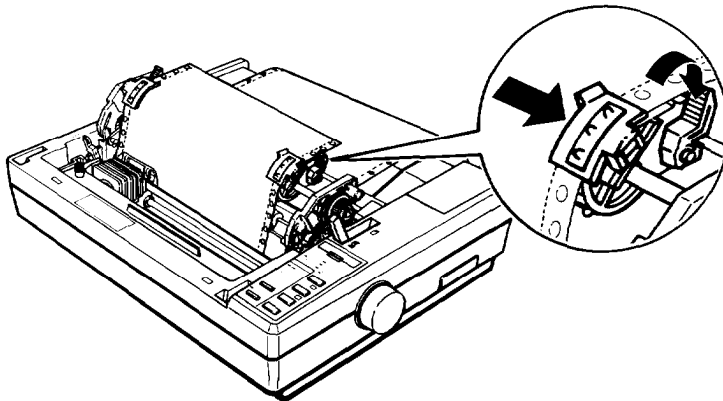

9. Install the paper guide. Slide the edge guides all the way apart.

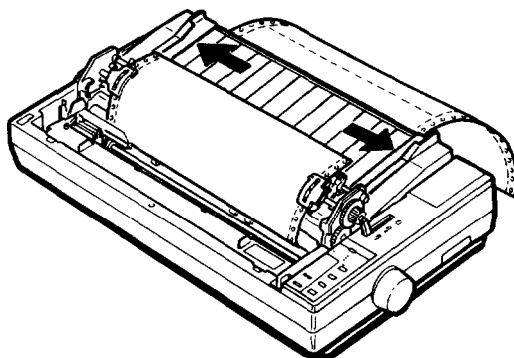

10. Separate the clear plastic part of the printer cover from the printer cover by pressing on the tabs on each side.

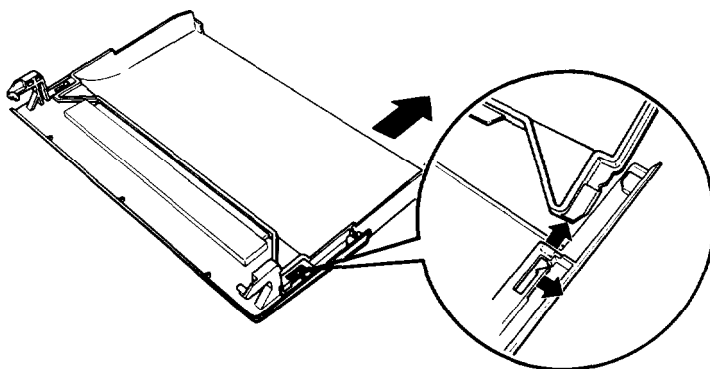

11. Attach the clear plastic part included with the pull tractor to the printer cover.

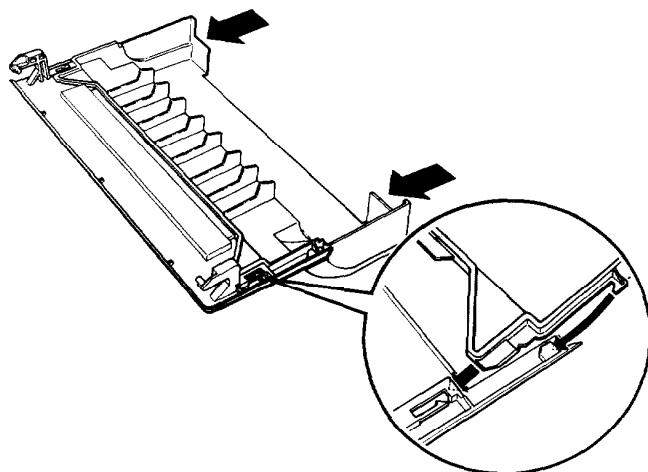

12. Attach the pull tractor cover and press the **ON LINE** button the printer on line.

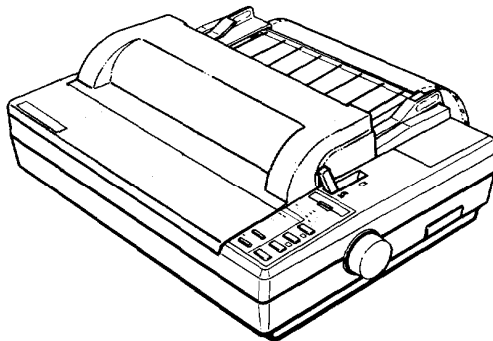

Although the pull tractor can be used in combination with the built-in push tractor as described above, the pull tractor can also be used by itself. Instead of setting the paper on the pins of the push tractor, simply insert it through the same paper path as you would use with single sheets of paper.

**Note:** Do not use the short tear-off feature with the pull tractor.

## Removing the Pull Tractor

1. Make sure to tear off the printed document and remove the tractor cover and paper guide. Then turn on the printer.
2. Press the **ON LINE** button to set the printer off line. Then, press the **LOAD/EJECT** button until the continuous paper feeds backward out of the paper path to the standby position. The **PAPER OUT** light comes on when the paper is completely out of the paper path.

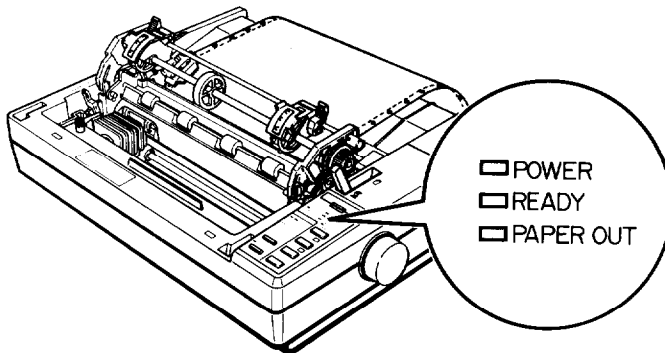

3. Remove the continuous paper from the push tractor unit.

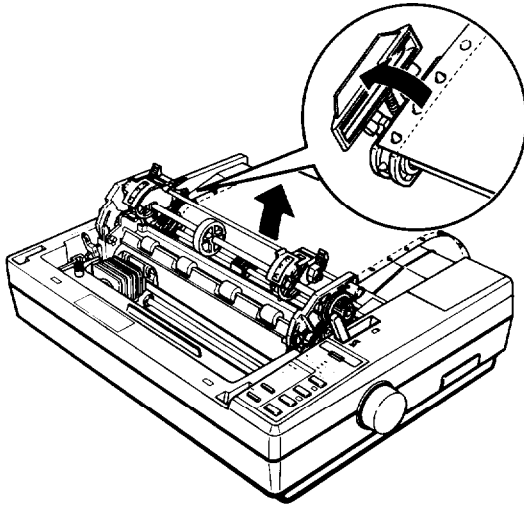

4. Place your thumbs beside the front latches on each end of the tractor unit and gently push up on them, slowly tilting the unit back. Push the paper release lever to the back position.

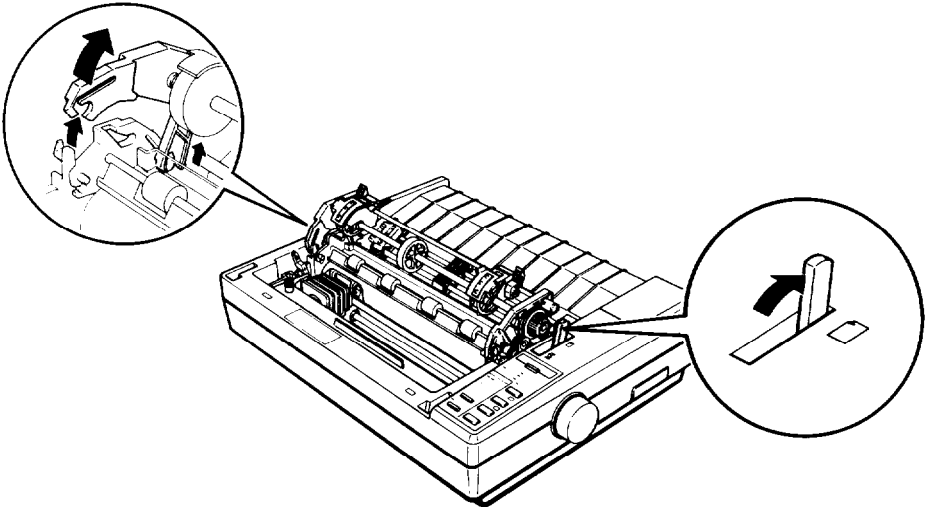

5. On the standard width printer, replace the paper tension unit cover.

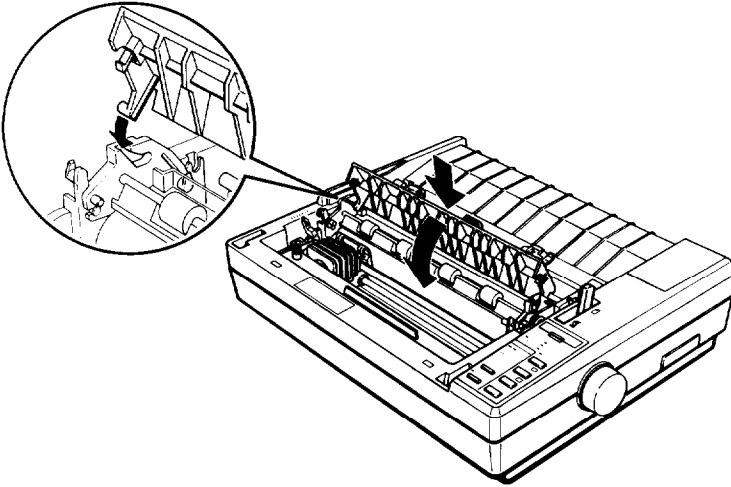

On the wide carriage printer, replace the paper tension unit.

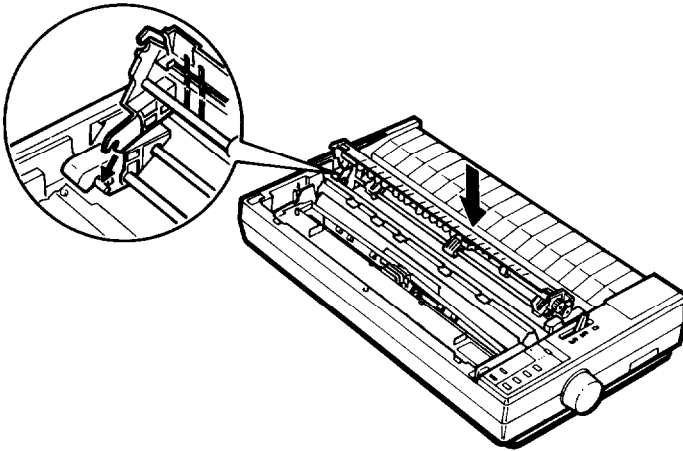

6. Remove the tractor cover from the printer cover and reassemble the printer cover.
7. Install the paper guide and printer cover.

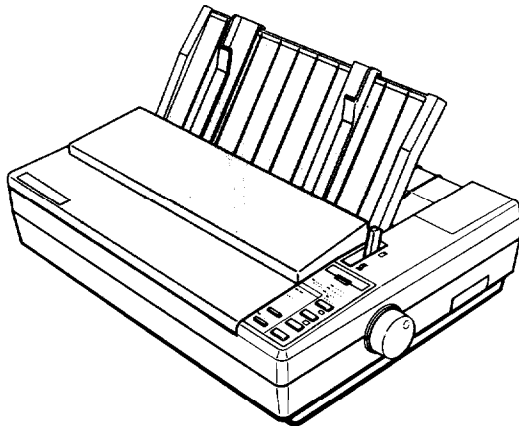



## The Interface Boards

A number of optional interfaces are available that supplement the capabilities of your printer's built-in parallel interface.

### Choosing an Interface

Optional interfaces can be divided into four main categories which are described briefly below.

- Serial interfaces are required if your computer is not equipped with a parallel interface or if you need an interface that conforms to the Current Loop standard instead of RS-232C. These interfaces also provide some combination of the following features: X-ON/X-OFF data communication protocol, loopback self test modes, and data buffers that increase the printer's data buffering capacity by 8 KB.
- IEEE-488 interfaces offer standardized connections, trouble-free operation, and the ability to connect computers, printers, and other devices on the same line so that they may share data freely.
- Third-party interfaces, such as Coax and Twinax, allow Epson printers to function as local IBM printers without the addition of any other circuitry or components.
- The buffered parallel interfaces also offer trouble-free operation and standardized connections. They provide the printer with more memory to free the computer for other tasks when printing large amounts of text or graphics. You can increase the printer's data buffering capacity by an additional 32 KB (about 10 pages).

If you are not sure whether you need an optional interface or would like to know more about interfaces, contact your dealer or call the Consumer Information number listed in Where to Get Help.

## Compatible Interfaces

The following is a list of Epson interfaces that are compatible with your printer.

Interface number	Name
#8143	New Serial Interface
#8148	Intelligent serial interface
#8185	intelligent IEEE-488 interface
C823032	32KB buffered parallel interface expandable to 512KB
C823021	32KB buffered serial interface expandable to 512KB

All Epson interfaces have the Epson name printed on them. If the board has an identification code printed **on** it, it is a four-digit number beginning with 8 and should correspond to one of the numbers listed in the table above.

Coax and Twinax interfaces are also available from Epson dealers. These interfaces allow connectivity to mainframe and minicomputers and emulation of IBM printers.

## Installation

The optional interface boards available for your printer are easy to install. The only tool needed is a cross head screwdriver.

1. Turn off the printer. Then unplug the printer and remove the printer cover and paper guide.



**WARNING:** High voltages are present inside the printer when the power is on. Do not attempt to remove the upper case unless the printer is turned off and the power cord is unplugged. Also, try not to touch contacts on the circuit board of the printer because many of the components can be destroyed by the static electricity present in your body.

Do not change the settings of any DIP switches on the main board.

2. Remove the screw securing the interface board cover and lift off the cover.

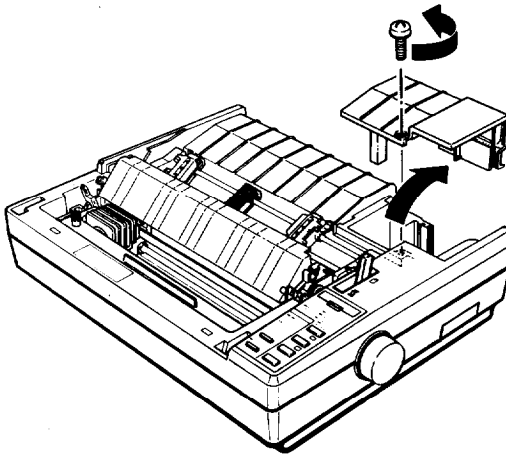

3. Remove the screw labeled CG from the main board.

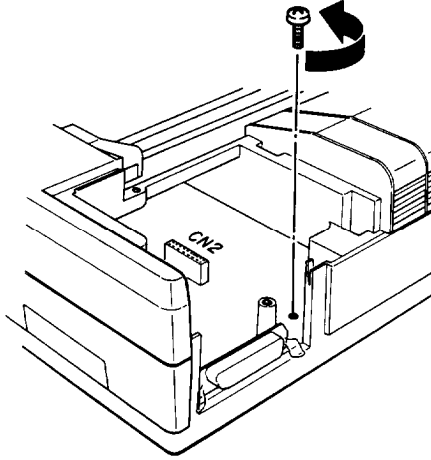

### Installing the board

There are two basic interface board designs—one with the FG wire not attached and one with the FG wire attached. This slight difference changes the way the boards are installed in the printer but does not affect the operation of the interface in any way. Check to see which type of interface board you have.

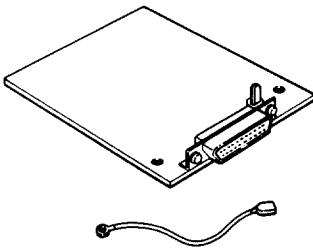

FG wire not attached

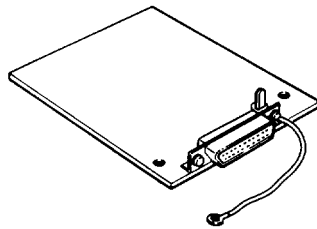

FG wire attached

If the FG wire is not attached, follow these steps:

1. Use the CG screw to attach the round end of the FG (frame ground) wire to the main board and position the other end as shown.

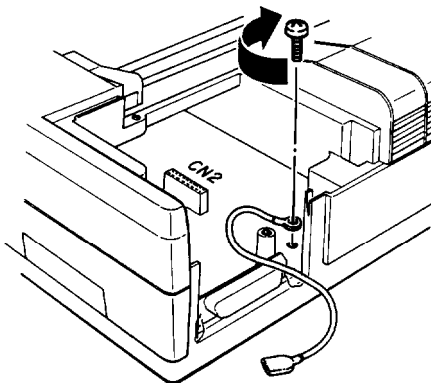

2. Carefully insert the pins on the optional interface board into the mating connector on the main board; then secure the board with the screws provided.

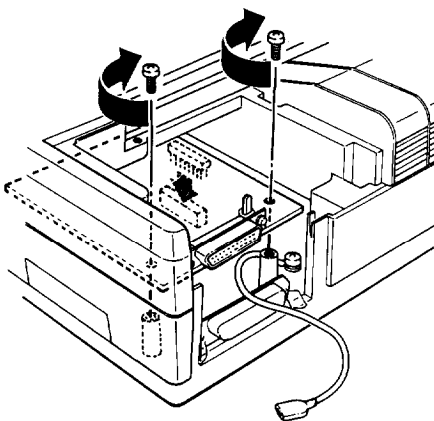

3. Attach the plug end of the FG wire onto the FG pin located on top of the interface board.

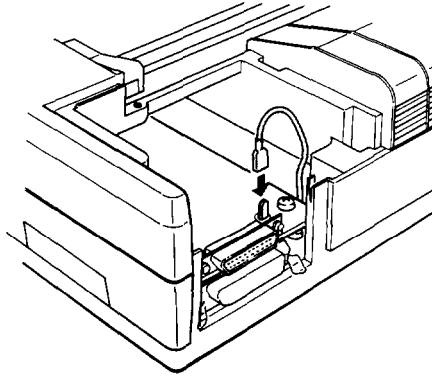

4. Set the DIP switches on the interface board according to the manual accompanying it.

If the FG wire is attached, follow these steps:

1. Carefully place the interface board next to the printer. Use the CG screw to connect the round end of the FG (frame ground) wire to the main board.

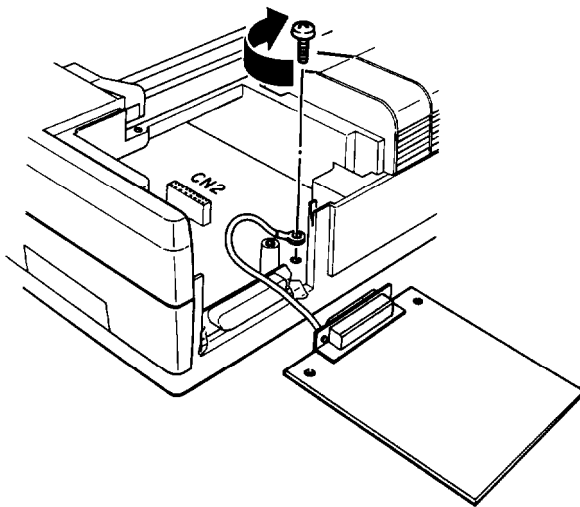

2. Holding the interface board level, rotate it into position and attach it to the main board. Make sure that the connector pins are properly inserted into the mating connector.

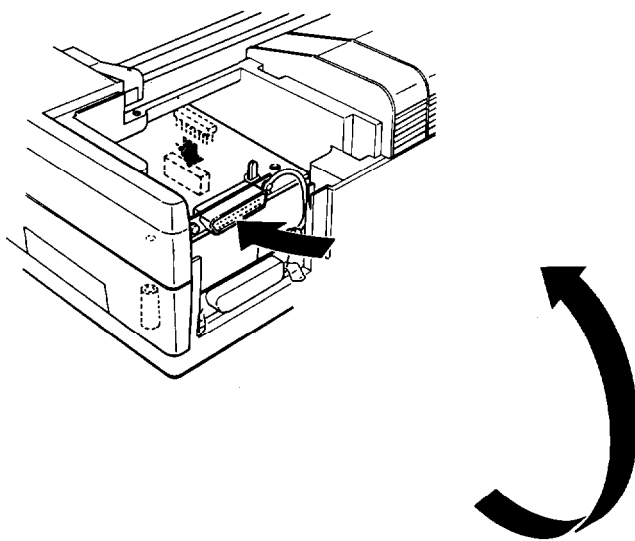

3. Secure the board with the screws provided.

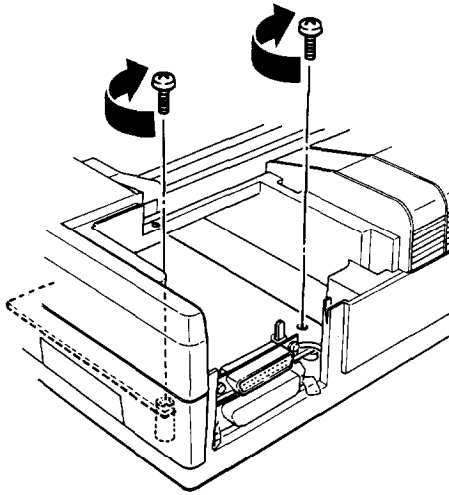

4. For all interface boards except #8143 New Serial Interface board, set the DIP switches *on* the interface board according to the manual accompanying it. If you have the #8143 board, see the next section.

#### **Attaching the interface board cover**

1. Bend back the hinge plate on the interface board cover.

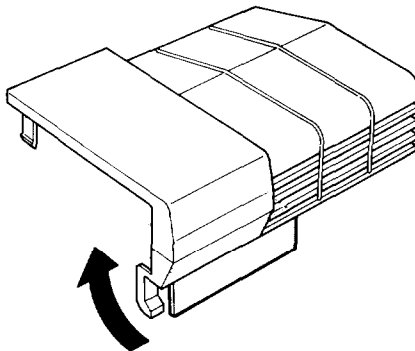



Note: When you reattach the interface board, rebend the plate to cover the opening. The plate is sturdy, but be careful not to subject it to excessive bending.

2. Reattach the board cover.

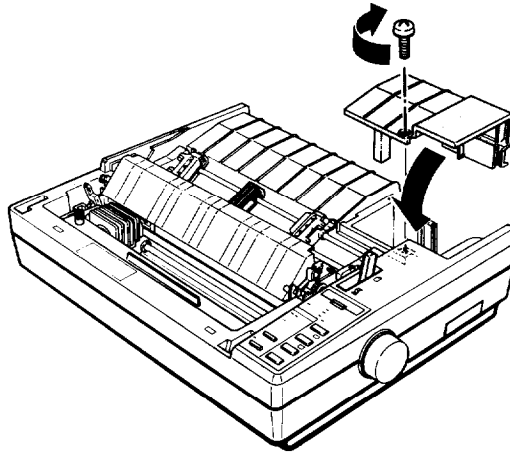

**CAUTION:** When an optional interface board is installed, be sure to disconnect the printer cable from the printer's built-in parallel interface. Two interface cables must not be connected at the same time.

## **#8143 New Serial Interface**

If you are using an optional interface, it may be necessary for you to alter the communication protocol of the printer or the computer so that they can communicate properly. In most cases, you should use the information in your optional interface manual or your computer's manual to match the computer with the interface.

If you are using the #8143 optional interface board, make sure that you read through the section below on baud rate selection. You may also want to see the sections on handshaking timing and error handling for interface information specific to your printer.

For all other data transfer conventions, such as word structure or communications protocol, use the information in the manual supplied with your #8143 optional interface.

### **Baud rate selection**

You can select baud rates from 75 to 19,200 BPS (Bits Per Second). When setting the baud rate, make sure you use the bit rate selection table for printers with buffers (in the #8143 interface manual).

For more information on the printer's input buffer settings, see Setting the DIP Switches in Chapter 3 of this manual.

### **Handshaking timing**

When the vacant area for data in the input buffer drops to 256 bytes, the printer outputs an X-OFF code or sets the DTR flag to 1 (MARK) indicating that it cannot receive data.

### **Error handling**

When a parity error is detected, your printer prints an asterisk (\*). All other errors, including framing and overnm, are ignored.

# **Chapter 6**

## **Maintenance**

Cleaning the Printer .....	6-2
Replacing the Ribbon .....	6-4
Transporting the Printer. ....	6-10

## Cleaning the Printer

To keep your printer operating at its best, you should clean it thoroughly several times a year. Follow the steps below.

1. Make sure that the printer is turned off. Then remove the paper guide or the cut sheet feeder.
2. Using a soft brush, carefully remove all dust and dirt.

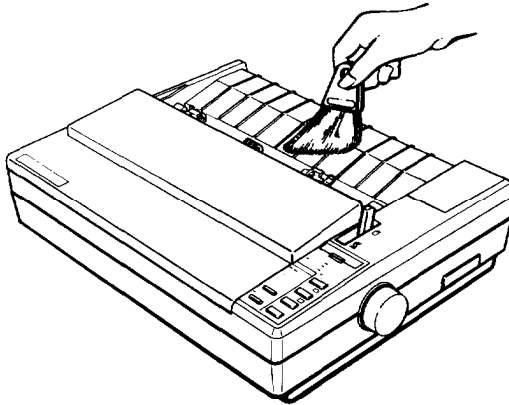

3. If the outer case or paper guide is dirty or dusty, clean it with a soft, clean cloth dampened with a mild detergent solution. Keep the printer cover in place to prevent water from getting inside the printer.

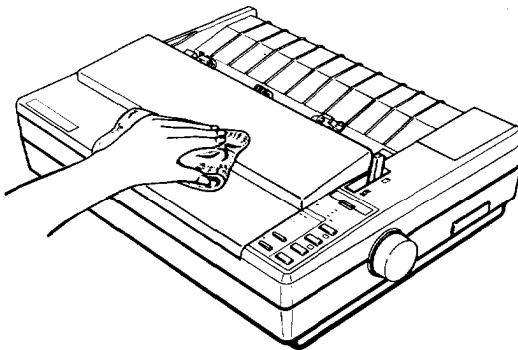

**CAUTIONS:**

- Never use alcohols or thinners to clean the printer because these chemicals can damage the components as well as the case.
- Be careful not to get water on the printer mechanism or electronic components.
- Do not use a hard or abrasive brush.
- Do not spray the inside of the printer with lubricants; unsuitable oils can damage the mechanism. If you think lubrication is needed, contact your dealer or call the Consumer Information number listed in Where to Get Help.

# Replacing the Ribbon

Replace the ribbon when the printout becomes too faint. The following Epson replacement ribbon cartridges are available:

Printer	Standard ribbon	Film ribbon
Standard width printer	#7753	#7768
Wide carriage printer	#7754	#7770

Notes:

- Use the optional film ribbon only when you need especially high quality printing. For everyday operations, use the standard ribbon.
  - Do not use ribbons designed for nine-pin printers.
1. Make sure that the printer is turned off. Then remove the printer cover.
  2. On the standard width printer, open the paper tension unit cover.

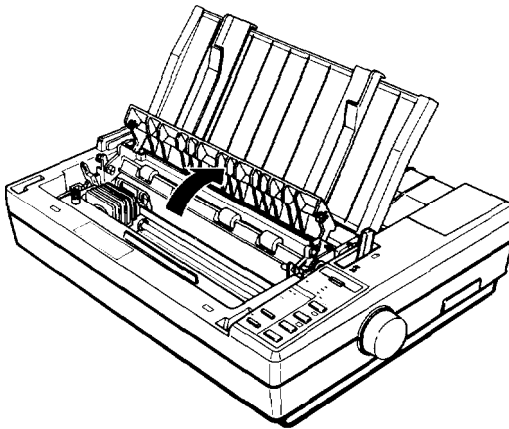

On the wide carriage printer, remove the paper tension unit.

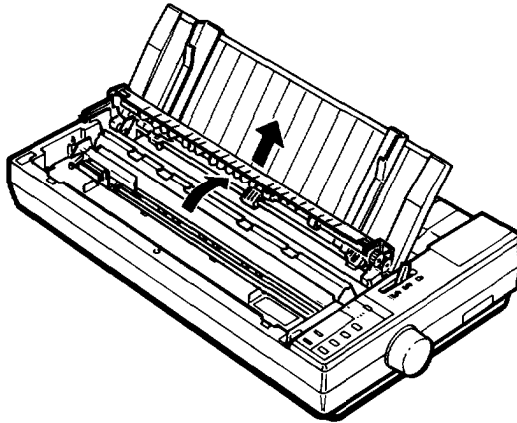

3. To remove the ribbon cartridge, grip it by the black plastic tab and lift the cartridge straight up and out of the printer.

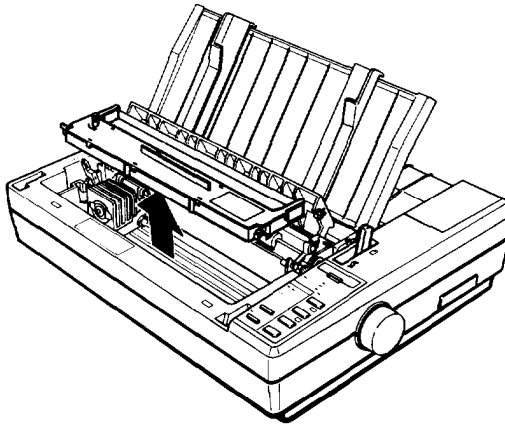

**WARNING:** If the printer has just been used, the print head may be hot. Let it cool before attempting to replace the ribbon.

4. Slide the print head to the middle of the printer.

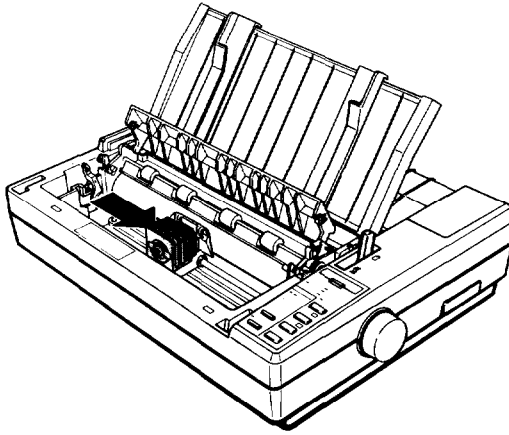

5. To remove slack in the new ribbon, turn the ribbon-tightening knob in the direction of the arrow.

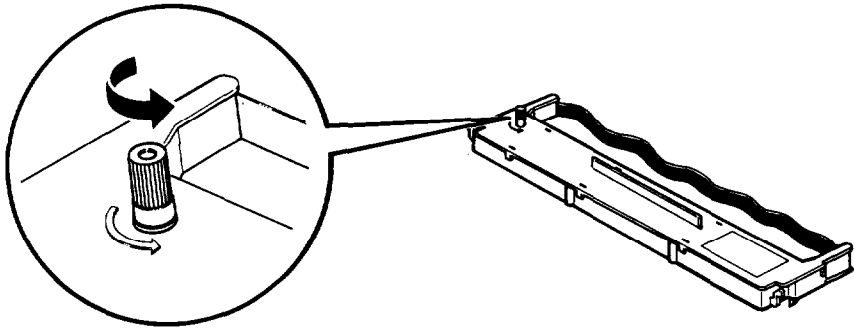

6. Push the new ribbon cartridge firmly into position, making sure the plastic hooks fit into the slots.



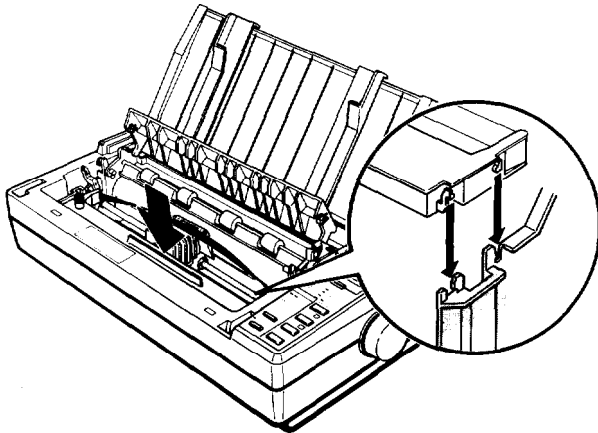

Note: Press lightly on both sides of the cartridge to make sure the hooks are properly inserted.

7. Use a pointed object, such as a ball point pen, to guide the ribbon between the print head and ribbon guide while you turn the ribbon-tightening knob to help feed the ribbon into place. Be careful not to puncture the ribbon.

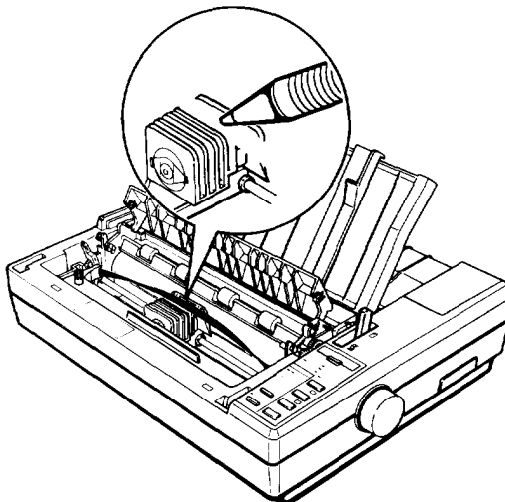

8. Slide the print head from side to side to make sure it moves smoothly. **Also see that the ribbon is not twisted or creased.**

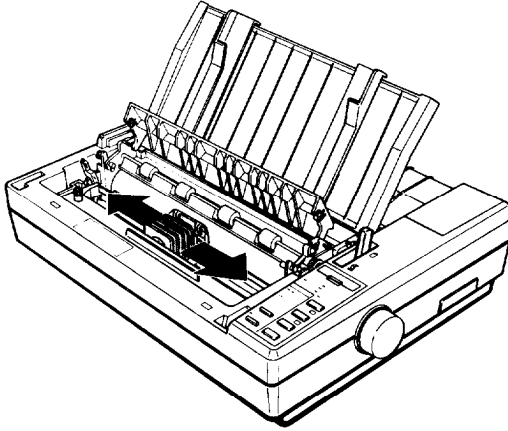

9. On the standard width printer, close the paper tension unit cover.

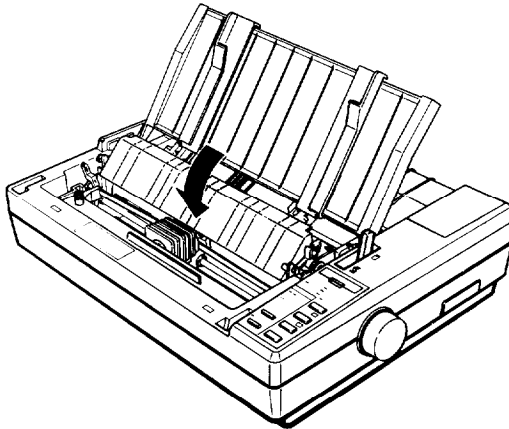

On the wide carriage printer, attach the paper tension unit.

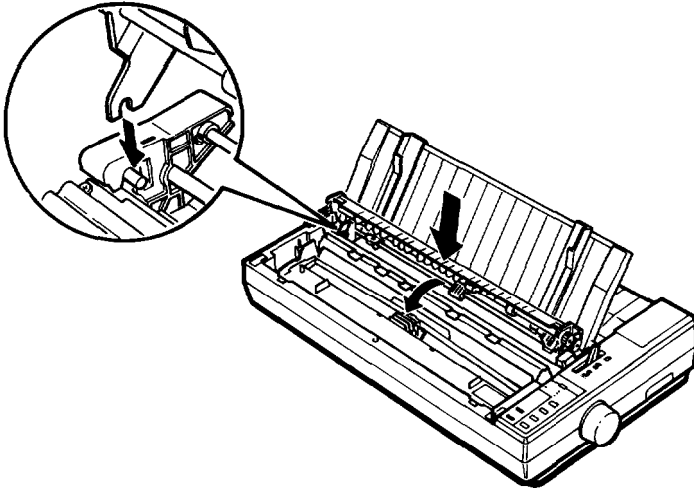

10. Insert the hooks on the printer cover unit into the printer, and then tilt the printer cover back into place.

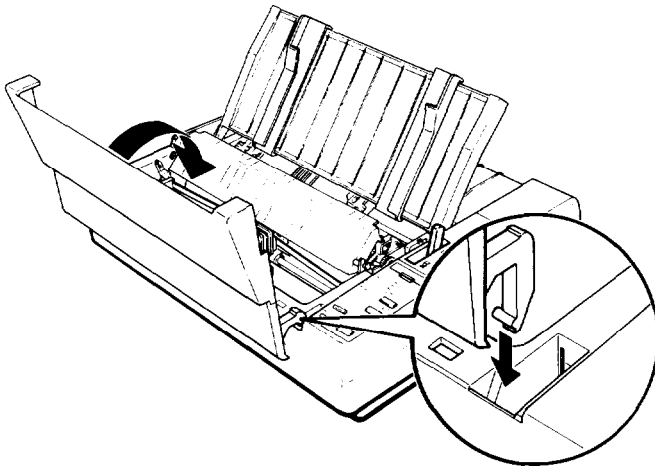

## Transporting the Printer

Before you transport your printer some distance, carefully repack it in the original box and packing materials according to the following instructions.

1. Make sure the printer is turned off. Then remove any installed options, as well as the paper guide and printer cover.



**CAUTION:** Turn the printer off before unplugging the power cable from the AC outlet.

2. Unplug the power cable from the electrical outlet. Coil the cable and tie it; then disconnect the interface cable from the printer and the computer.
3. Remove the ribbon cartridge-and platen knob.

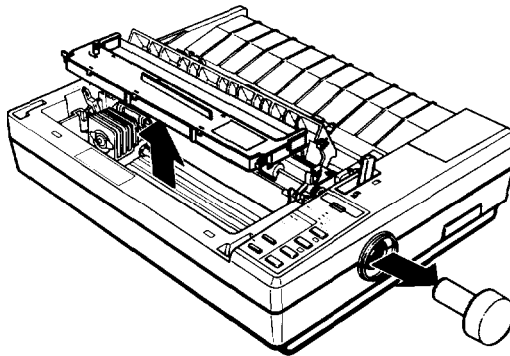

4. On the wide carriage printer, you need to replace the locking clip. Remove the paper tension unit. Then attach the locking clip.

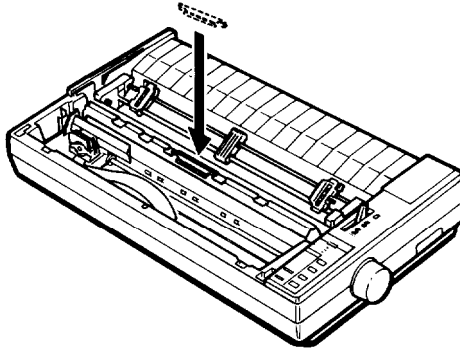

Then replace the paper tension unit.

5. Reattach the printer cover.
6. Replace the packing materials and put the printer in its box.

# Chapter 7

## Troubleshooting

Printing .....	7-2
Paper Handling .....	7-7
Options.. .....	7-10



## Printing

This section supplies solutions for possible printer problems.

### **Power is not being supplied.**

- *The POWER light does not go on.*

Check that the power cable is plugged properly into the electrical outlet.

Make sure the power switch is turned on.

If the electrical outlet is controlled by an outside switch or automatic timer, use a different outlet.

Plug another electrical device into the outlet to determine whether the outlet is operating properly.

### **The printer does not print.**

- *The **ON LINE** light is off.*

Press the **ON LINE** button to set the printer on line.

- *The **ON LINE** light is on but nothing is printed.*

Check both ends of the interface cable between the printer and the computer. Make sure your interface cable meets both the printer and the computer specifications.

The software may not be installed properly for your printer. Check the printer settings for your software.

- *The **PAPER OUT** light is on.*

Load paper in the printer.

- *The printer sounds like it is printing, but nothing is printed.*

The ribbon cartridge **may** not be installed properly. Turn off the printer and reinstall the ribbon cartridge.

The ribbon may be worn. Replace the ribbon cartridge.

- *The printer makes a strange noise, the buzzer sounds several times, and the printer stops abruptly.*

Turn off the printer and check for paper jams or other problems; then turn the printer back on. If the printer still does not print correctly, contact your dealer or call the Consumer Information number listed in Where to Get Help.

- *The **ON LINE** light is flickering but the printer does not print, or it stops printing abruptly.*

The print head is overheated. Wait a few minutes; the printer resumes printing automatically when the print head cools.

### **The print is faint or uneven.**

- *Printed characters have parts missing at the bottom.*

The ribbon cartridge may not be installed properly. Remove the ribbon cartridge and reinstall it.

- *The printout is faint.*

The ribbon may be worn out. Replace the ribbon cartridge.

Check that the paper thickness lever is set correctly for the paper you are using.



## **Dots are missing in the printed characters or graphics.**

- *A line of dots is missing in the printout.*

The print head is damaged. Stop printing and contact your dealer to have the printer repaired.

- *Dots are missing in random positions.*

There is either too much slack in the ribbon or the ribbon has come loose. Reinstall the ribbon cartridge.

## **Printed characters are not what you expected.**

- *The typestyle or characters that are set by your software cannot be printed.*

Check that the software is correctly installed for your printer.

- *You selected a font using SelectType, but the characters are printed in a different font.*

Your software may be overriding your SelectType setting. Check the font selected by your software.

- *The wrong characters are printed.*

The wrong graphics character set or international character set is selected. Check the DIP switch settings.

- *The characters printed are smaller than expected.*

Check the font selected through your software.

Check the **CONDENSED** light on the control panel. If it is on, press the **CONDENSED** button to cancel the mode.

## **The print position is not what you expected.**

- *Printing starts too high or too low on the page.*

Use micro-adjustment to adjust the loading position.

Check the top margin set by your application software and adjust it.

- *All the text is printed on the same line.*

Set DIP switch 2-4 on so the printer automatically adds a line feed code to each carriage return.

- *The text is printed with an extra blank line in between.*

Two line feed signals are being sent. Set DIP switch 2-4 off.

- *Page length does not match the length of the paper.*

Check the page length set by DIP switches 1-4 and 1-5.

Check the page length set by your application software and adjust it if necessary.

- *Regular gaps occur in the printout.*

One-inch skip over perforation may be set. Set DIP switch 2-3 to off.

- *Skip over perforation is set, but the perforation does not fall in the center of the skip.*

Adjust the loading position.

- *Vertical printed lines do not align* □ *gaps appear in lines or graphics.*

The printer is usually set for bidirectional printing. This can cause a slight misalignment of graphics characters. When precise printing of vertical lines is necessary, contact your dealer to have the bidirectional print alignment adjustment performed.

You can also select unidirectional printing by setting DIP switch 2-6 to off. Unidirectional printing is slightly slower.

If the printer still does not print, disconnect the printer from your computer and try the self test described in Chapter 1. If the self test works properly, the printer is working, and the problem probably lies in the computer, the software, or the cable. If the self test does not work or if any other problem persists, contact your dealer or call the Consumer Information number listed in Where to Get Help.

---

## Paper Handling

The following section guides you through problems in handling single sheets of paper and continuous paper. If you are having problems using the optional cut-sheet feeder or pull tractor, see Options later in this chapter.

### Single sheets do not feed properly.

- *Paper was inserted in the sheet guide, but the platen did not move and paper was not fed.*

The left edge guide may be set too far to the right so that the paper detector cannot sense it. Move the paper a little to the left. The PAPER OUT light should go off.

- *Paper was inserted in the sheet guide, and the platen rotated, but paper was not fed.*

Check that the paper release lever is pushed back to the single sheet position.

Check that the paper guide is installed properly.

The left and right edge guides may be too close together, preventing the paper from feeding smoothly. Adjust the position of the edge guides so that the paper can move up and down freely.

The paper may not be firmly inserted. When feeding thicker than normal paper, press down lightly on the paper.

- *Paper loads, but then jams.*

The cut sheet feeder mode may be turned on (DIP switch 1-8 is on). When the cut sheet feeder is not in use, DIP switch 1-8 should be off.

The edge guides may be too far apart. Adjust the edge guides to the width of the paper.

The dimensions of the paper may exceed the specified limitations. Use only paper sizes that are within the specified range. Multi-part forms **cannot** be used with this printer's single sheet feeding system.

### **Continuous paper does not feed properly.**

- *When the **LOAD/EJECT** button is pressed, the platen does not rotate and paper does not feed.*

You may be trying to feed paper using the control panel buttons while the printer is on line (ON LINE light on). Press the ON LINE button once to set the printer off line; then try feeding paper. After feeding paper, press the ON LINE button again to set the printer on line.

The paper release lever may be pushed back to the single sheet position. When using the tractor, be sure the paper release lever is pulled forward to the continuous paper position.

On the wide carriage printer, the paper release lever must be in the center position when using the built-in push tractor, and it must be in the forward position **when** using the optional pull tractor.

- *When the **LOAD/EJECT** button is pressed, the platen rotates but paper does not feed.*

Continuous paper may **have** already been in the paper path. (In this case, the paper feeds backward to the standby position.) Press the **LOAD/EJECT** button again to load the paper.

- *The paper feed is crooked or the paper jams.*

Make sure **the** paper supply is not obstructed by a cable or some other object, and **that** the paper feeds smoothly into the printer.

Check that the holes **on** the sides of **the** paper are aligned with each other. **Also**, make sure **the** sprocket lock levers are locked and the sprocket covers are closed.

- *The short tear-off function does not work.*

Make sure DIP switch 2-2 is set to on.

Short tear-off is performed whenever the printer receives a full page of data or a form feed and no more data is received for three seconds. Make sure your software sends a form feed at the end of a document.

# Options

This section describes problems you may encounter while using the optional cut sheet feeder or an optional interface board.

## **With the cut sheet feeder, paper does not feed properly.**

- *When a print command is sent from the computer, the platen rotates, but paper does not feed.*

Make sure DIP switch 1-8 is on.

Make sure the cut sheet feeder is correctly installed on the printer.

Check that the paper release lever is pushed back to the single sheet position.

Make sure paper is loaded in the cut sheet feeder's bin. If only one sheet is left in the bin, add more paper.

- *Two or more sheets feed at the same time.*

You may have loaded too many sheets in the cut sheet feeder's bin.

You may have forgotten to fan the stack of paper before loading it into the bin. Remove the paper and fan it.

- *The paper feed is crooked.*

The paper may be old or creased. Use only new, clean sheets of paper.

Make sure that your paper is the proper size and quality.

- *One page of printing has spread to two pages.*

Check that the page length setting is correct.

**With an optional interface, the printer does not operate properly.**

- *The printer does not print or the printout is not what you expected.*

Check that the interface board is correctly inserted into the connector on the main board.

Check the specifications to make sure that you can use the interface with this printer.

Make sure that the cable matches the interface specifications.

Check that the DIP switches or jumpers on the interface board are set correctly. Also, make sure that the computer and interface settings match.



# Chapter 8

## Technical Specifications

Printer Specifications .....	8-2
Printing .....	8-2
Paper.. .....	8-3
Mechanical .....	8-7
Electrical.. .....	8-8
Environment. ....	8-8
Interface Specifications .....	8-9
Pin Assignments for the Parallel Interface .....	8-9
Interface Timing. ....	8-11
Printing Enabled/Disabled Signals and Control Conditions .....	8-12
Option Specifications .....	8-13
Cut Sheet Feeder .....	8-13
Initialization. ....	8-15
Default Settings .....	8-15

---

# Printer Specifications

## Printing

**Print method:** 24-pin impact dot matrix

**Print speed:**

Quality	Characters per inch	Characters/second/line
Draft	10	160
	12	192
LQ	10	53
	12	64

**Printing direction:** Bidirectional logic-seeking for text printing. Unidirectional for graphics (can also be switched to bidirectional by using the proper software command when DIP switch 2-6 is on).

**Line spacing:** 1/6 inch or programmable in increments of 1/360th of an inch

**Paper feed speed:** 2.2 inches per sec (100 ms/line)  
(continuous feed)

**Printable columns:**

Character spacing	Maximum printed characters	
	Standard width printer	Wide carriage printer
10 cpi	80	136
10 cpi condensed	137	233
12 cpi	96	164
12 cpi condensed	160	272

**Input buffer:** 8 KB/1 KB  
(DIP switch selectable)

**Character fonts:**

Font	Available (Characters per inch)	Family number
Draft	10, 12, 15	
Epson Roman	10, 12, 15, Proportional	0
Epson Sans Serif	10, 12, 15, Proportional	1
Epson Courier	10, 12, 15	2
Epson Prestige	10, 12, 15	3
Epson Script	10, 12, 15	4
OCR-B	10	5
OCR-A	10	6
Epson Orator	10	7
Epson Orator-S	10	8

**Characters:** 96 standard ASCII character set (including italic characters)  
15 international character sets  
5 graphics character sets (also called code page tables)

**Paper**

**Paper feeding methods:** Friction  
Built-in push feed tractor with paper tension unit  
Pull tractor (optional)  
Cut sheet feeder (optional)

**Paper width and length:**

Paper	Standard width printer	Wide carriage printer
Single sheet width	7.2 to 10.1 inches (182 to 257 mm)	7.2 to 14.3 inches (182 to 364 mm)
length	7.2 to 14.3 inches (182 to 364 mm)	7.2 to 14.3 inches (182 to 364 mm)
Continuous paper width	4.0 to 10.0 inches (101 to 254 mm)	4.0 to 16.0 inches (101 to 406 mm)
Envelopes	No. 6 6.54 x 3.62 inches (166 x 92 mm) No. 10 9.45 x 4.09 inches (240 x 104 mm)	
Labels	2.5 x 0.94 inch (63.5 x 23.8 mm ) minimum	

**Printable area:** Single sheet

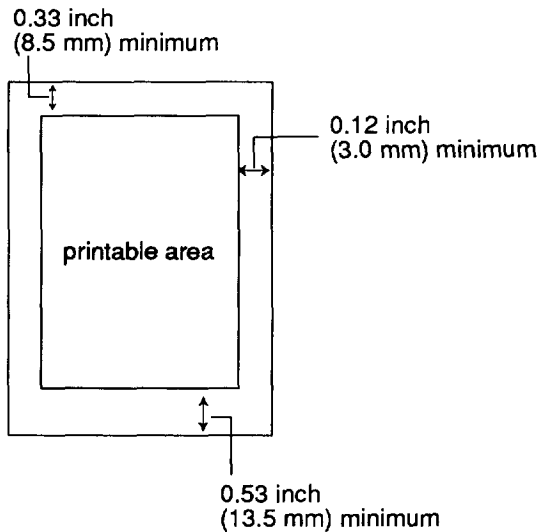

**Note:** For the standard width printer, printing on paper from 9 to 10 inches wide increases the minimum right and left margins to 0.9 inch (24 mm).

Continuous paper

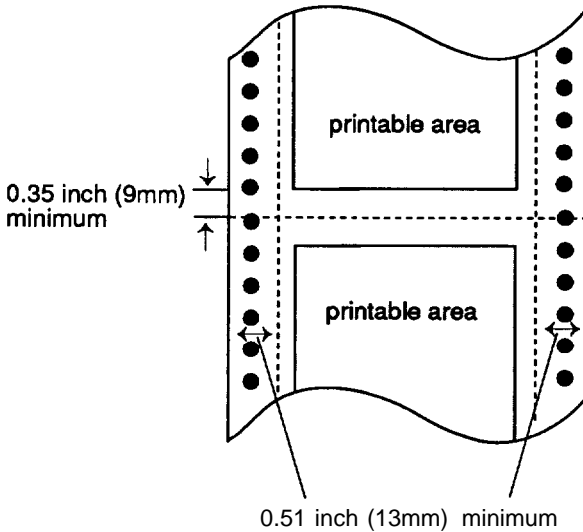

**Note:** The minimum for the right and left margins increases to 0.98 inch (25 mm) when printing on 10-inch wide paper on the standard width printer or on 15- to 16-inch wide paper on the wide carriage printer.

## Envelope

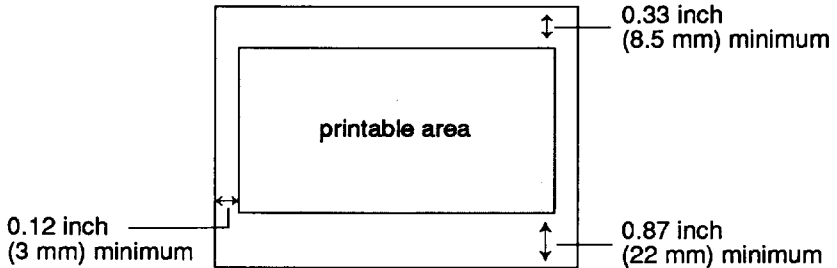

**Note:** Envelope printing is only available at normal operating conditions. Load the envelope with its long side horizontal.

### ***Paper weight:***

Single Sheet	14 lb to 24 lb
Continuous	14 lb to 22 lb
Multi-part forms	12 lb to 15 lb per sheet. Maximum number sheets = 3
Envelope	12 lb to 24 lb

### ***Paper thickness:***

Single Sheet	0.0025 to 0.0055 inches (0.065 to 0.14 mm)
Continuous	0.0025 to 0.0098 inches (0.065 to 0.25 mm)
Envelope	0.0063 to 0.0197 inches (0.16 to 0.52 mm)
Label (with backing)	0.0075 inches (Maximum 0.19 mm)

### ***Number of copies:***

Up to 3 sheets including the original.  
Total thickness must not exceed 0.01 inches  
(0.25 mm).

**Notes:**

- The use of 24 lb paper is only available at normal temperature.
- Printing past the edge of envelopes, multi-part forms, labels, or paper that is thicker than normal can damage the print head.
- Labels with a pressure sensitive covering, either glued or tacked onto the backing sheet, can be printed under the conditions listed below.
  - The total thickness may not exceed 0.0118 inch (0.3 mm).
  - The temperature range is between 40°F and 95°F (5°C to 35°C).
  - The relative humidity is between 10 and 80 percent.

**Mechanical*****Ribbon:***

Black ribbon cartridge #7753/#7754:

Life expectancy (in Letter Quality characters, at 48 dots/character)  
2 million characters

Film ribbon cartridge #7768/#7770:

Life expectancy (in Letter Quality characters, at 48 dots/character)  
0.2 million characters

***MCBF:***

For all components excluding print head:  
3,000,000 lines

***MTBF:***

Standard width printer:  
4000 power-on hours (at 25% duty)  
Wide carriage printer:  
6000 power-on hours (at 25% duty)

***Print head life:***

200 million strokes per wire  
(with fabric ribbon)

## ***Dimensions and weight:***

	<b>Standard width printer (80)</b>	<b>Wide carriage printer (136)</b>
<b>Height</b>	5.51 inches (139.9 mm)	5.69 inches (144.5 mm)
<b>Width</b>	16.46 inches (418 mm)	23.35 inches (593 mm)
<b>Depth</b>	13.66 inches (347 mm)	13.68 inches (347.5 mm)
<b>Weight</b>	approx. 13.2 lb (6 kg)	approx. 17.6 lb (8 kg)

## **Electrical**

***Voltage:*** 120 VAC  $\pm$  10%

***Power consumption:*** 100 watts maximum

***Frequency:*** 50  $\pm$  0.5 Hz, 60  $\pm$  0.5 Hz

***Insulation resistance:*** 10 Mohms between AC power line and chassis

***Dielectric strength (between AC line and chassis):*** Can withstand 1.0 kV rms applied for one minute, or 1.2 kV applied for one second

## **Environment**

***Temperature:*** Operation: 40°F to 95°F (5°C to 35°C)  
Storage: -22°F to 140°F (-30°C to 60°C)

***Humidity:*** Operation: 10% to 80% (noncondensing)  
Storage: 5% to 85% (noncondensing)

***Shock:*** Operation: Up to 1 G within 1 ms  
Storage: Up to 2 G within 1 ms

***Vibration:*** Operation: Up to 0.25 G at up to 55 Hz  
Storage: Up to 0.50 G at up to 55 Hz

***Operation angle:*** Less than 15° (without cut sheet feeder)  
0° (with cut sheet feeder)

## **8-8 Technical Specifications**



## Interface Specifications

Your printer is equipped with an 8-bit parallel interface. For specifications on optional interfaces, refer to their manuals.

### Pin Assignments for the Parallel Interface

Connector pin assignments and a description of their respective interface signals are shown in the following table.

Signal Pin	Return Pin	Signal	Direction	Description
1	19	STROBE	IN	STROBE pulse to read data. Pulse width must be more than 0.5 microseconds at the receiving terminal.
2	20	DATA 1	IN	These signals represent information of the 1st to 8th bits of parallel data, respectively. Each signal is at HIGH level when data is logical 1 and LOW when it is logical 0.
3	21	DATA 2	IN	
4	22	DATA 3	IN	
5	23	DATA 4	IN	
6	24	DATA 5	IN	
7	25	DATA 6	IN	
8	26	DATA 7	IN	
9	27	DATA 8	IN	
10	28	ACKNLG	OUT	About an 11-microsecond pulse. LOW indicates that data has been received and that the printer is ready to accept more data.
11	29	BUSY	OUT	A HIGH signal indicates that the printer cannot receive data. The signal goes HIGH in the following cases: 1) During data entry (ea. char. time) 2) During printing 3) When off line 4) During printer-error state
12	30	PE	OUT	A HIGH signal indicates that the printer is out of paper.

Signal Pin	Return Pin	Signal		Description
13	-	SLCT	OUT	Pulled up to +5 volts through 3.3 Kohm resistance.
14	- - -	Auto FEED XT	IN	When this signal is LOW, the paper is automatically fed 1 line after printing. (The signal level can be fixed to this by setting DIP switch 2-4 to on.)
15		NC	-	Not used.
16		GND	-	Logic ground level.
17	- -	CHASSIS GND	- -	Printer's chassis ground, which is isolated from the logic ground.
18	-	<b>NC</b>	-	Not used.
19-30	-	GND	-	Twisted-pair return signal ground level.
31	16	INIT	IN	When this level becomes LOW, the printer controller is reset to its power-up state and the print buffer is cleared. This level is normally HIGH; its pulse width must be more than 50 microseconds at the receiving terminal.
32	-	ERROR	OUT	This level becomes LOW when the printer is: 1) in paper out state. 2) off line. 3) in error state.
33	-	GND	-	Same as for Pins 1 Q-30.
34	-	<b>NC</b>	-	Not used.
35	-	-	OUT	Pulled up to 5V through 3.3 Kohm resistance.
36	-	SLCT IN	IN	The DC1/DC3 code is valid only when this signal is HIGH. (Internal fixing can be carried out with Jumper J10. The level of this signal is factory-set to LOW.)

- The column heading “Direction” refers to the direction of signal flow as viewed from the printer.
- “Return” denotes the twisted-pair return, to be connected at signal ground level. For the interface wiring, be sure to use a twisted-pair cable for each signal and to complete the connection on the return side. These cables should be shielded and connected to the chassis of the host computer and the printer.
- All interface conditions are based on TTL level. Both the rise and the fall times of each signal must be less than 0.2 microseconds.
- Data transfer must be carried out by observing the ACKNLG or BUSY signal. Data transfer to this printer can be carried out only after receipt of the ACKNLG signal or when the level of the BUSY signal is LOW.

### Interface Timing

The figure below shows the timing for the parallel interface.

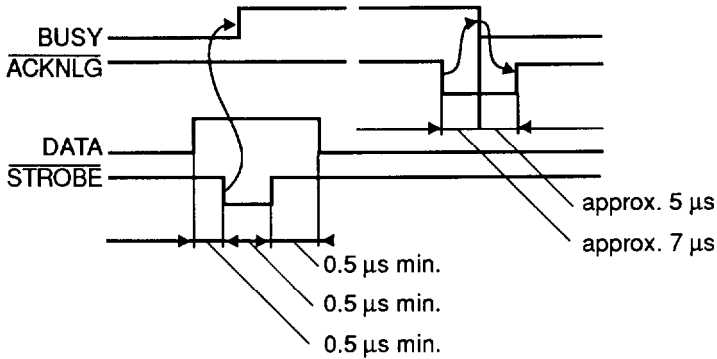

## Printing Enabled/Disabled Signals and Control Conditions

The table below shows the relationship between printing being enabled or disabled, the on line/off line status, and the receipt of the data on/off control characters, DC1 or DC3.

ON LINE (Indicator on)	SLCT IN	DC1/DC3 (Data on/off control)	ERROR	BUSY	ACKNLG	Printing (Disabled/enabled)
On line	Low (J10 interface)	DC1/DC3 (no effect)	High	High/Low	Pulsed each character	Enabled (normal condition)
On line	High	DC1 Recv'd	High	High/Low	Pulsed each character	Enabled
On line	High	DC3 Recv'd	High	High/Low	Pulsed each character	Disabled*
Off line	High/Low (no effect)	DC1/DC3 (no effect)	Low	High	Not generated	Disabled

- While printing is disabled, character data is being received and acknowledged so that the printer can look for another DC1 character, which would allow it to resume printing.

# Option Specifications

## Cut Sheet Feeder

### *Dimensions and weight:*

Option no.	Height	Width	Depth	Weight
C806 122	16.7 inches (423 mm)	17.5 inches (444 mm)	17.1 inches (434 mm)	2.4 lb (1.1 kg)
C806242	16.4 inches (416 mm)	24.3 inches (618 mm)	17.4 inches (443 mm)	5.9 lb (2.7 kg)

Dimensions: mounted on printer.

### ***Bin and Stacker capacity:***

Single sheet: Up to 100 sheets of 24 lb (90g/m<sup>2</sup>) paper  
Up to 185 sheets of 17 lb (64g/m<sup>2</sup>) paper  
(total thickness should be up to 0.59 inch or 15 mm)

***MCBF:*** 100,000 cycles

### ***Environmental condition:***

Temperature  
Operation: 40°F to 95°F (5°C to 35°C)  
Storage: -22°F to 140°F (-30°C to 60°C)  
Humidity  
Operation: 15% to 80% (noncondensing)  
Storage: 5% to 85% (noncondensing)

**Paper:**

	<b>C806122</b>	<b>C806242</b>
<b>Width</b>	7.17 to 8.5 inches (182 to 216 mm)	7.17 to 14.33 inches (182 to 364 mm)
<b>Length</b>	8.27 to 14.3 inches (210 to 364 mm)	10.12 to 14.33 inches <b>(257 to 364 mm)</b>
<b>Thickness</b>	0.0028 to 0.005 inches (0.07 to 0.14 mm)	
<b>Weight</b>	17 to 24 lb (64 to 90 g/m*)	

**Printable area**

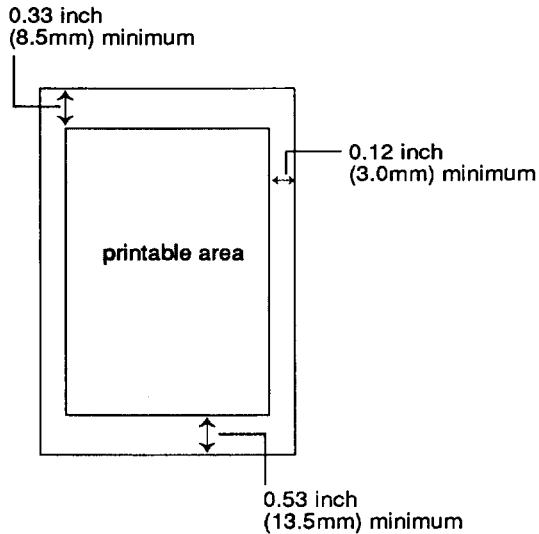

**Note:** The use of 24 lb paper is available only at normal temperature. Paper feed accuracy cannot be assured within 0.9” (22 mm) from either the top or bottom edges of the paper.

**Storage condition:** Temperature 65°F to 70°F (18°C to 22°C)  
Humidity 40% to 60%

**8-14 Technical Specifications**

## **Initialization**

There are two ways that the printer can be initialized (returned to the default settings) through the hardware and one way through the software. These are described in the following table.

Hardware initialization	<ul style="list-style-type: none"><li>The power is turned on. The printer receives an INIT signal at the parallel interface (pin 31 goes LOW).</li></ul>
Software initialization	<ul style="list-style-type: none"><li>The software sends the ESC @ (initialize the printer) command.</li></ul>

## **Default Settings**

The table below shows the default conditions that become valid when the printer is initialized.

<b>Item</b>	<b>Reset to:</b>
Top of form position	Current paper position
Left and right margins	Cancelled
Line spacing	1/6-inch line spacing
Vertical tab position	Cleared
Horizontal tab positions	Every eight characters
VFU channel	Channel 0
Font selection	Hardware: The current DIP switch setting Software: The current SelecType setting
Condensed mode	Hardware: The current DIP switch setting Software: The current SelecType setting
Character spacing	The current DIP switch setting
Justification	Left justification
Special printing effects	Cancelled (except condensed printing)
Graphic mode assignment	ESC K = ESC* 0, ESC L = ESC* 1, ESC Y = ESC* 2, ESC Z = ESC* 3

Also, the data buffer is cleared when the printer is initialized by turning on the power or by an INIT signal.

Note: The user-defined character set is not cleared when the printer is initialized with the software command (ESC @).



# Chapter 9

## Command Summary

Using the Command Summary. ....	9-2
Control Key Chart. ....	9-4
Commands in Numerical Order. ....	9-5
Commands Arranged by Topic. ....	9-8
Printer Operation. ....	9-8
MSBControl. ....	9-11
Data Control. ....	9-12
Vertical Motion. ....	9-13
Horizontal Motion. ....	9-19
Overall Printing Style. ....	9-22
Print Size and Character Width. ....	9-24
Print Enhancement. ....	9-28
Word Processing. ....	9-33
Character Sets. ....	9-34
User-defined Characters. ....	9-36
Graphics. ....	9-38

---

## Using the Command Summary

This chapter lists and describes all the commands available on the printer.

The first part of this chapter lists all commands in numerical order and gives the number of the page where each is fully described. If you know which command you are looking for, consult the **numerical list**.

**Note:** The Quick Reference card at the end of the book also contains a list of the commands divided by topic, with page number references that direct you to full explanations of the commands.

The second part of this chapter lists and describes each command separately; the commands are divided into the following subjects:

Printer operation	Print size and character width
MSB control	Print enhancement
Data control	Word processing
Vertical motion	Character sets
Horizontal motion	User-defined characters
Overall printing style	Graphics

Each command description has a format section and a comment section. The format section gives the ASCII, decimal, and hexadecimal values for the command. These three formats are equivalent, and it should be easy to pick **the one most** suited to your purpose. The comment section describes the effect of the command and gives **any** additional information necessary for using it.

**Note:** Some application programs use control key sequences. See the Control Key chart later in this chapter.

The simplest type of command consists of a single character to be sent to the printer. For instance, to print in condensed mode, the code format is:

ASCII code:       SI  
 Decimal:           15  
 Hexadecimal:   OF

This code **can be sent** from a program by sending the code 15 directly.

More complex commands consist of two or more character codes. For example, to print in double-wide mode, the code format is the following:

ASCII code:   ESC   W   n  
 Decimal:       27   87   n  
 Hexadecimal:  1B   57   n

In this case *n* can be either 1 (on) or 0 (off), to begin or end double-width printing. You can use either of the following commands to **turn** on double-width print from BASIC:

**LPRINT CHR\$(27);CHR\$(87);CHR\$(1)**  
**LPRINT CHR\$(27);"W";CHR\$(1)**

For the following commands that use only 0 or 1 for the variable, either the decimal or hexadecimal values 1 and 0 or **the** ASCII characters 1 and 0 can be used:

ESC U, ESC x, ESC p, ESC W, ESC S, ESC-, and ESC %

For example, in BASIC you can turn on proportional spacing with either of these statements:

**LPRINT CHR\$(27);"p";CHR\$(1)**  
**LPRINT CHR\$(27);"p";"1"**

## Control Key Chart

Some application programs use control key codes for decimal values 0-27. The table below gives you the proper values. The Control Key column indicates that you press the control key at the same time you press the key for the letter or symbol in that column. For example, you press the control key and A at the same time to send the value 1.

Some application programs that use this system cannot use Control-@, and many programs use the control keys for other purposes.

Dec.	Hex.	Ctrl. Key
0	00	@
1	01	A
2	02	B
3	03	C
4	04	D
5	05	E
6	06	F
7	07	G
8	08	H
9	09	I
10	0A	J
11	0B	K
12	0C	L
13	0D	M

Dec.	Hex.	Ctrl. Key
14	0E	N
15	0F	O
16	10	P
17	11	Q
18	12	R
19	13	S
20	14	T
21	15	U
22	16	V
23	17	W
24	18	X
25	19	Y
26	1A	Z
27	1B	[

## Commands in Numerical Order

The following list shows control codes and ESC sequences with their decimal and hexadecimal values, and the page where the description of the command can be found.

ASCII	Dec.	Hex.	Description	Page
BEL	7	07	Beeper. ....	9-12
BS	8	08	Backspace .....	9-20
HT	9	09	Tab Horizontally .....	9-21
LF	10	0A	Line Feed .....	9-14
VT	11	0B	Tab Vertically .....	9-17
FF	12	0C	Form Feed .....	9-13
CR	13	0D	Carriage Return .....	9-12
SO	14	0E	Select Double-width Mode (one line) .....	9-26
SI	15	0F	Select Condensed Mode .....	9-25
DC1	17	11	Select Printer. ....	9-8
DC2	18	12	Cancel Condensed Mode .....	9-26
DC3	19	13	Deselect Printer. ....	9-9
DC4	20	14	Cancel Double-width Mode (one line) .....	9-27
CAN	24	18	Cancel Line .....	9-12
DEL	127	7F	Delete Character. ....	9-9
ESC SO	14	0E	Select Double-width Mode (one line) .....	9-27
ESC SI	15	0F	Select Condensed Mode .....	9-26
ESC EM	25	19	Control Cut Sheet Feeder .....	9-10
ESC SP	32	20	Set Intercharacter Space .....	9-33
ESC !	33	21	Master Select .....	9-23
ESC #	35	23	Cancel MSB Control. ....	9-11
ESC \$	36	24	Set Absolute Print Position. ....	9-20
ESC %	37	25	Select User-defined Set .....	9-37
ESC &	38	26	Define User-defined Characters.	9-36
ESC (-	40	28	Select Score .....	9-31

<b>ASCII</b>	<b>Dec.</b>	<b>Hex.</b>	<b>Description</b>	<b>Page</b>
ESC *	42	2A	Select Graphics Mode . . . . .	9-39
ESC +	43	2B	Set n/360-inch Line Spacing. . . .	9-15
Esc -	45	2D	Turn Underline Mode on/Off. . . . .	9-32
Esc /	47	2F	Select Vertical Tab Channel . . . .	9-18
ESC 0	48	30	Select 1/8-inch Line Spacing . . .	9-15
ESC 2	50	32	Select 1/6-inch Line Spacing . . .	9-15
ESC 3	51	33	Set n/180-inch Line Spacing. . . .	9-16
ESC 4	52	34	Select Italic Mode . . . . .	9-34
ESC 5	53	35	Cancel Italic Mode . . . . .	9-35
ESC 6	54	36	Enable Printable Characters . . . .	9-37
ESC 7	55	37	Enable Upper Control Codes . . .	9-37
ESC :	58	3A	Copy ROM to RAM. . . . .	9-36
ESC <	60	3C	Select Unidirectional Mode (one line) . . . . .	9-9
ESC =	61	3D	Set MSB to 0 . . . . .	9-11
ESC >	62	3E	Set MSB to 1. . . . .	9-11
ESC ?	63	3F	Reassign Graphics Mode. . . . .	9-40
ESC 8	64	40	Initialize Printer . . . . .	9-8
ESC A	65	41	Set n/60-inch Line Spacing. . . .	9-16
ESC B	66	42	Set Vertical Tabs . . . . .	9-17
ESC C	67	43	Set Page Length in Lines . . . . .	9-13
ESC C0	67	43	Set Page Length in Inches . . . . .	9-13
ESC D	68	44	Set Horizontal Tabs . . . . .	9-22
ESC E	69	45	Select Emphasized Mode . . . . .	9-28
ESC F	70	46	Cancel Emphasized Mode . . . . .	9-28
ESC G	71	47	Select Double-strike Mode . . . . .	9-29
ESC H	72	48	Cancel Double-strike Mode . . . .	9-29
ESC J	74	4A	Perform n/180-inch Line Feed . .	9-16
ESC K	75	4B	Select Single-density Graphics Mode . . . . .	9-38
ESC L	76	4C	Select Double-density Graphics Mode . . . . .	9-38
ESC M	77	4D	Select 12 CPI . . . . .	9-24

## 9-6 Command Summary

<b>ASCII</b>	<b>Dec.</b>	<b>Hex.</b>	<b>Description</b>	<b>Page</b>
ESC N	78	4E	Set Skip Over Perforation . . . . .	9-14
ESC O	79	4F	Cancel Skip Over Perforation. ..	9-14
ESC P	80	50	Select 10 CPI . . . . .	9-24
ESC Q	81	51	Set Right Margin. . . . .	9-19
ESC R	82	52	Select an International Character Set. . . . .	9-35
ESC S 0	83	53	Select Superscript Mode . . . . .	9-29
ESC S 1	83	53	Select Subscript Mode . . . . .	9-30
ESC T	84	54	Cancel Superscript/Subscript Mode . . . . .	9-30
ESC U	85	55	Turn Unidirectional Mode On/Off. . . . .	9-10
ESC W	87	57	Turn Double-width Mode On/Off . . . . .	9-27
ESC Y	89	59	Select High-speed Double-density Graphics Mode . . . . .	9-38
ESC Z	90	5A	Select Quadruple-density Graphics Mode . . . . .	9-39
ESC \	92	5C	Set Relative Print Position. . . . .	9-21
ESC a	97	61	Select Justification . . . . .	9-33
ESC b	98	62	Set Vertical Tabs in Channels ...	9-18
ESC g	103	67	Select 15 CPI . . . . .	9-24
ESC k	107	6B	Select Typestyle Family. . . . .	9-22
ESC l	108	6C	Set Left Margin . . . . .	9-19
ESC p	112	70	Turn Proportional Mode On/Off. . . . .	9-25
ESC q	113	71	Select Character Style . . . . .	9-32
ESC t	116	74	Select Character Set . . . . .	9-34
ESC w	119	77	Turn Double-height Mode On/Off . . . . .	9-28
ESC x	120	78	Select Letter Quality or Draft ...	9-22

# Commands Arranged by Topic

This following section lists and describes all the commands by topic. See the Quick Reference card at the back of this book for a handy list of commands by topic.

## Printer Operation

**ESC @**

**Initialize Printer**

---

Format:

ASCII code:	ESC	@
Decimal:	27	64
Hexadecimal:	1B	40

Comments:

Resets the printer mode and clears the current print line preceding the command.

**DC1**

**Select Printer**

---

Format:

ASCII code:	DC1
Decimal:	17
Hexadecimal:	11

Comments:

Returns the printer to the selected state if it has been deselected by the printer deselect code (DC3). It does not select the printer if it has been switched off line by the **ON LINE** button.

**Note:** DC1 and DC3 do not work if pin 36 on the parallel interface is low.



**DC3****Deselect Printer**

---

## Format:

ASCII code: DC3  
Decimal: 19  
Hexadecimal: 13

## Comments:

Puts the printer into the deselected state until the select printer code (DC1) is received. The printer cannot be reselected with the ON LINE button.

**DEL****Delete Character**

---

## Format:

ASCII code: DEL  
Decimal: 127  
Hexadecimal: 7F

## Comments:

Removes the last text character on the print line but does not affect control codes.

**ESC <****Select Unidirectional Mode (one line)**

---

## Format:

ASCII code:	ESC	<
Decimal:	27	60
Hexadecimal:	1B	3C

## Comments:

Printing is normally bidirectional. This command selects unidirectional printing for one line only. (It is cancelled by a carriage return.) The print head moves to the extreme left (**home**) position and printing takes place from left to right. Overrides the DIP switch setting.

## **ESC U** **Turn Unidirectional Mode On/Off**

---

Format:

ASCII code:	ESC	U	n
Decimal:	27	85	n
Hexadecimal:	1B	55	n

Comments:

The following values can be used for n:

- 1: Turns the mode on
- 0: Turns the mode off

Printing is normally bidirectional. This command selects unidirectional printing for more accurate positioning.

## **ESC EM** **Control Cut Sheet Feeder**

---

Format:

ASCII code:	ESC	EM	n
Decimal:	27	25	n
Hexadecimal:	1B	19	n

Comments:

The following values can be used for n:

- 0: Turns mode off
- 4: Turns mode on
- R: Ejects a sheet. (No paper is loaded.)

The command should not be used unless the cut sheet feeder is installed. It is ignored if any value other than 0, 4, or R is used for n.

The cut sheet feeder mode can also be turned on and off by setting DIP switch 1-8.

## MSB Control

MSB means **the** Most Significant Bit. MSB control (ESC =, ESC >, and ESC #) does **not** work for graphics or user-defined characters.

---

### ESC = Set MSB to 0

Format:

ASCII code:	ESC	
Decimal:	27	61
Hexadecimal:	1B	3D

Comments:

Sets the MSB of all incoming data to 0. Some computers always send data with the MSB set to 1, which means **that** italics or character graphics are always printed. ESC = **can** overcome this problem.

---

### ESC > Set MSB to 1

Format:

ASCII code:	ESC	
Decimal:	27	62
Hexadecimal:	1B	3E

Comments:

Sets the MSB bit of all incoming data as 1.

---

### ESC # Cancel MSB Control

Format:

ASCII code:	ESC	#
Decimal:	27	35
Hexadecimal:	1B	23

Comments:

Cancels **the** MSB control set by ESC = or ESC >.

**BEL****Beeper**

---

Format:

ASCII code: BEL  
Decimal: 7  
Hexadecimal: 07

Comments:

Sounds the printer's beeper.

**Data Control****CR****Carriage Return**

---

Format:

ASCII code: CR  
Decimal: 13  
Hexadecimal: 0D

Comments:

Prints the data in the print buffer and returns the print position to the left margin. A line feed is added if the AUTO FEED XT line on the parallel interface is held LOW.

**CAN****Cancel Line**

---

Format:

ASCII code: CAN  
Decimal: 24  
Hexadecimal: 18

Comments:

Clears all text on the print line, but does not affect control codes.

## Vertical Motion

FF

Form Feed

Format:

ASCII code:       FF  
Decimal:           12  
Hexadecimal:   0C

Comments:

Prints the data in the print buffer and advances the paper to the top of the next form according to the current page length. When using a cut sheet feeder, FF ejects the sheet into the stacker.

ESC C

Set Page Length in Lines

Format:

ASCII code:       ESC    C    *n*  
*Decimal:*        27     67     *n*  
Hexadecimal:    1B     43     *n*

Comments:

Sets the page length to *n* lines in the current line spacing. The value of *n* must be from 1 to 127 lines. The top of form position is reset to the current line.

Overrides the DIP switch setting for page length.

ESC C 0

Set Page Length in Inches

Format:

ASCII code:       ESC    C    0    *n*  
*Decimal:*        27     67     0    *n*  
Hexadecimal:    1B     43     00    *n*

Comments:

Sets the page length to *n* inches. The value of *n* must be from 1 to 22. The top of form position is reset to the current line.

Overrides the DIP switch setting for page length.

---

**ESC N** **Set Skip Over Perforation**

---

**Format:**

ASCII code:	ESC	N	<i>n</i>
Decimal:	27	78	<i>n</i>
Hexadecimal:	1B	4E	<i>n</i>

**Comments:**

The variable *n* is the number of lines skipped between the last line printed on one page and the first line to print on the next page.

For example, with the standard setting for line spacing (1/6-inch), and page length (66 lines), ESC N 6 prints 60 lines and then skips 6. This setting is cancelled by ESC O, ESC C, or ESC C 0. The value of *n* must be from 1 to 127.

Overrides the DIP switch setting for 1-inch skip over perforation.

---

**ESC O** **Cancel Skip Over Perforation**

---

**Format:**

ASCII code:	ESC	O
Decimal:	27	79
Hexadecimal:	1B	4F

**Comments:**

Cancels the skip over perforation set by ESC N.

Overrides the DIP switch setting for 1-inch skip over perforation.

---

**LF** **Line Feed**

---

**Format:**

ASCII code:	LF
Decimal:	10
Hexadecimal:	0A

**Comments:**

When this command is received, the data in the print buffer is printed and the paper advances one line in the current line spacing.

**ESC 0** **Select 1/8-inch Line Spacing**

---

**Format:**

<b>ASCII code:</b>	<b>ESC</b>	<b>0</b>
<b>Decimal:</b>	27	48
<b>Hexadecimal:</b>	1B	30

**Comments:**

Sets the line spacing to 1/8 of an inch for subsequent line feed commands.

**ESC 2** **Select 1/6-inch Line Spacing**

---

**Format:**

<b>ASCII code:</b>	<b>ESC</b>	<b>2</b>
<b>Decimal:</b>	27	50
<b>Hexadecimal:</b>	1B	32

**Comments:**

Sets the line spacing to 1/6 of an inch for subsequent line feed commands. This line spacing is the default at power on.

**ESC +** **Set n/360-inch Line Spacing**

---

**Format:**

<b>ASCII code:</b>	<b>ESC</b>	<b>+</b>	<b>n</b>
<b>Decimal:</b>	27	43	n
<b>Hexadecimal:</b>	1B	2B	n

**Comments:**

Sets line spacing to n/360 of an inch for subsequent line feed commands. The value of n must be from 0 to 255.

**ESC 3****Set  $n/180$ -inch Line Spacing****Format:**

ASCII code:	ESC	3	n
Decimal:	27	51	n
Hexadecimal:	1B	33	n

**Comments:**

Sets the line spacing to  $n/180$  of an inch for subsequent line feed commands. The value of  $n$  must be from 0 to 255.

**ESC A****Set  $n/60$ -inch Line Spacing****Format:**

ASCII code:	ESC	A	n
Decimal:	27	65	n
Hexadecimal:	1B	41	n

**Comments:**

Sets the line spacing to  $n/60$  of an inch for subsequent line feed commands. The value of  $n$  must be from 0 to 85.

**ESC J****Perform  $n/180$ -inch Line Feed****Format:**

ASCII code:	ESC	J	n
Decimal:	27	74	n
Hexadecimal:	1B	4A	n

**Comments:**

Advances the paper  $n/180$  of an inch. The value of  $n$  must be from 0 to 255. This command produces an immediate line feed but does not affect subsequent line spacing and does not produce a carriage return.



## VT

## Tab Vertically

---

### Format:

ASCII code: VT  
Decimal: 11  
Hexadecimal: 0B

### Comments:

Advances the paper to the next vertical tab position in the channel selected by ESC /. If no channel has been selected, channel 0 is used. If no vertical tabs have been set, the paper advances one line.

## ESC B

## Set Vertical Tabs

---

### Format:

ASCII code:	ESC	B	<i>n1</i>	<i>n2</i>	...	<i>0</i>
Decimal:	<b>27</b>	<b>66</b>	<i>n1</i>	<i>n2</i>	...	<i>0</i>
Hexadecimal:	1B	42	<i>n1</i>	<i>n2</i>	...	<i>00</i>

### Comments:

Sets up to 16 vertical tabs in the current line spacing. Tab settings are **not** affected by subsequent changes in line spacing. The tab settings are entered as *n1*, *n2*, etc.—all from 1 to 225, in ascending order. The 0 value (null) indicates the end of the command. All settings are stored in channel 0 (see ESC b). ESC B 0 clears the tab settings.

**ESC b** **Set Vertical Tabs in Channels**

---

Format:

ASCII code:	ESC	b	c	n1	n2	...	0
Decimal:	27	98	c	n1	n2	...	0
Hexadecimal:	1B	62	c	<i>n1</i>	<i>n2</i>	...	<i>00</i>

Comments:

Functions the same as ESC B, except that the variable *c* selects **a** channel for the vertical tabs, which must be from 0 to 7. Therefore, up to eight sets of vertical tabs can be set. The channels are selected by ESC /. To clear the tabs in channel *c*, use ESC b *c* 0.

**ESC /** **Select Vertical Tab Channel**

---

Format:

ASCII code:	ESC	/	c
Decimal:	27	47	c
Hexadecimal:	1B	2F	c

Comments:

This command is used to select the vertical tab channel, with the value of *c* from 0 to 7. All subsequent VT commands use the channel selected by this command. If no channel has been selected, channel 0 is used.

## Horizontal Motion

### ESC 1

### Set Left Margin

Format:

ASCII code:	ESC	1	<i>n</i>
Decimal:	27	108	<i>n</i>
Hexadecimal:	1B	6C	<i>n</i>

Comments:

Sets the left margin to *n* columns in the current character size. Settings made in the proportional mode are treated as 10 cpi. This command clears previous tab settings and all previous characters in the print line. Use lowercase 1 (as in left), not the numeral one. The minimum space between the margins is the width of one double-width 10 cpi character.

### ESC Q

### Set Right Margin

Format:

ASCII code:	ESC	Q	<i>n</i>
Decimal:	27	81	<i>n</i>
Hexadecimal:	1B	51	<i>n</i>

Comments:

Sets the right margin to *n* columns in the current character size. Settings made in the proportional mode are treated as 10 cpi. This command clears previous tab settings and all previous characters in the print line. The minimum space between the margins is the width of **one** double-width 10 cpi character.

## Format:

ASCII code:       BS  
 Decimal:           8  
 Hexadecimal:   08

## Comments:

Prints out data in the print buffer, then moves the print position one space to the left. Backspacing is possible up to, but not beyond, the left margin setting. The BS code is ignored if ESC a2 or ESC a3 has been sent. If this code is received immediately after graphics printing, the print position of subsequent data is moved back to the point at which graphics printing started.

**ESC \$****Set Absolute Print Position**

## Format:

ASCII code:	ESC	\$	<i>n1</i>	<i>n</i>	<i>2</i>
Decimal:	27	36	<i>n1</i>		<i>n2</i>
Hexadecimal:	1B	24	<i>n1</i>		<i>n2</i>

## Comments:

This sequence specifies the distance from the current left margin that subsequent characters are to be printed, using this formula: total number of dots =  $n1 + (n2 \times 256)$ . Each unit equals 1/60th of an inch. The sequence is ignored and the previous setting remains effective if the position specified is beyond the right margin.

**ESC \****Set Relative Print Position**

---

## Format:

ASCII code:	ESC	\	<i>n1</i>	<i>n2</i>
Decimal:	27	92	<i>n1</i>	<i>n2</i>
Hexadecimal:	1B	5C	<i>n1</i>	<i>n2</i>

## Comments:

Determines the position (relative to the current position) at which printing of subsequent data will start. To find *n1* and *n2*, first calculate the displacement required in dots. If the displacement is to the left, subtract it from 65536. Send the resulting number using this formula: total number of dots =  $n1 + (256 \times n2)$ . The command is ignored if it would move the print position outside the current margins. A unit is 1/120th of an inch in draft, and 1/180th of an inch in Letter Quality or proportional modes.

**HT****Tab Horizontally**

---

## Format:

ASCII code:	HT
Decimal:	9
Hexadecimal:	09

## Comments:

Advances the print position to the next horizontal tab setting. The default tabs are at 8-character intervals in the currently set pitch. Tab positions are not affected by subsequent changes in cpi.

**ESC D** **Set Horizontal Tabs**

## Format:

ASCII code:	ESC	D	n1	n2	...	0
<i>Decimal:</i>	27	68	n1	n2	...	0
Hexadecimal:	1B	44	n1	n2	...	00

## Comments:

This command allows setting of up to 32 horizontal tabs, which are entered as *n1*, *n2*, *n3*, etc. (from 1 to 255), with the number 0 terminating the command. The tab settings must be entered in ascending order. ESC D 0 clears all tabs. The default settings, when power is turned on or after an ESC @ command, are at every eight characters. The tab settings are not affected by changes in cpi. The tab positions in proportional printing are determined by the 10 cpi character size.

## Overall Printing Style

**ESC x** **Select Letter Quality or Draft**

## Format:

ASCII code:	ESC	x	n
<i>Decimal:</i>	27	120	n
Hexadecimal:	1B	78	n

## Comments:

The following values can be used for n:

0: Selects draft mode.

1: Selects Letter Quality (LQ) mode.

Overrides the SelecType panel setting.

**ESC k** **Select Typestyle Family**

## Format:

ASCII code:	ESC	k	n
<i>Decimal:</i>	27	107	n
Hexadecimal:	1B	6B	n

Comments:

This command affects only the Letter Quality typestyle, not draft. If  $n = 0$ , typestyle in the printer is used. To select one of the other typestyles, use the family number of the font as shown below. For example, to choose the Prestige font, use 3 for the value of  $n$ . The following values can be used for  $n$ :

- 0: Roman                      3: Prestige                      6: OCR-A
- 1: Sans Serif                4: Script                        7: Orator
- 2: Courier                     5: OCR-B                        8: Orator-S

Overrides the SelecType panel setting.

ESC !

Master Select

Format:

ASCII code:	ESC	!	n
Decimal:	27	33	<b>n</b>
Hexadecimal:	1B	21	n

Comments:

Selects any valid combination of the following modes: 10 cpi, 12 cpi, proportional, condensed, emphasized, double-strike, double-width, italic, and underline.

The variable  $n$  identifies the mode or combination of modes. To find the value of  $n$ , use the following table to add up either the decimal or hexadecimal numbers for the features you want.

Feature	Dec.	Hex.
10 cpi	<b>0</b>	<b>00</b>
12 cpi	1	01
proportional	2	02
condensed	4	04
emphasized	8	08
double-strike	16	10
double-width	32	20
italics	64	40
underline	128	80

## Print Size and Character Width

### ESC P

Select 10 CPI

---

Format:

ASCII code:	ESC	P
Decimal:	27	80
Hexadecimal:	1B	50

Comments:

Selects 10 character per inch printing. This command is normally used to cancel 12 or 15 cpi.

### ESC M

Select 12 CPI

---

Format:

ASCII code:	ESC	M
Decimal:	27	77
Hexadecimal:	1B	4D

Comments:

Selects 12 character per inch printing.

### ESC g

Select 15 CPI

---

Format:

ASCII code:	ESC	g
Decimal:	27	103
Hexadecimal:	1B	67

Comments:

Selects 15 character per inch printing, and cancels 10 or 12 cpi. Cannot be combined with condensed mode.



**ESC p****Turn Proportional Mode On/Off**

---

## Format:

ASCII code:	ESC	p	n
Decimal:	27	112	n
Hexadecimal:	1B	70	n

## Comments:

Turns proportional mode on and off.

The following values can be used for *n*:

1: Turns mode on.

0: Turns mode off.

The width of proportional characters varies from character to character. Therefore, a narrow letter like *i* receives less space than a wide letter like *W*. Proportional character widths are given in the Appendix. Proportional mode is available only in Roman and Sans Serif fonts.

**SI****Select Condensed Mode**

---

## Format:

ASCII code:	SI
Decimal:	15
Hexadecimal:	0F

## Comments:

Prints characters at about 60 percent of their normal width. For example, the condensed 10 cpi mode has 17 characters per inch. Condensed mode cannot be combined with 15 cpi. Condensed can be turned on and off by SelectType, the SI command, or DIP switch 1-6.

**ESC SI****Select Condensed Mode**

---

**Format:**

<b>ASCII code:</b>	<b>ESC</b>	<b>SI</b>
<b>Decimal:</b>	27	15
<b>Hexadecimal:</b>	1B	0F

**Comments:**

Duplicates the SI command and the function of the CONDENSED button on the control panel.

**DC2****Cancel Condensed Mode**

---

**Format:**

<b>ASCII code:</b>	<b>DC2</b>
<b>Decimal:</b>	18
<b>Hexadecimal:</b>	12

**Comments:**

Cancels condensed mode set by SI, ESC SI, or SelecType and returns printing to normal.

**SO****Select Double-width Mode (one line)**

---

**Format:**

<b>ASCII code:</b>	<b>s o</b>
<b>Decimal:</b>	14
<b>Hexadecimal:</b>	0E

**Comments:**

Doubles the width of all characters on one line. This mode is cancelled by LF, FF, VT, or DC4.

**ESC SO** **Select Double-width Mode (one line)**

---

Format:

ASCII code:	ESC	SO
Decimal:	27	14
Hexadecimal:	1B	0E

Comments:

Duplicates the SO command.

**ESC W** **Turn Double-width Mode On/Off**

---

Format:

ASCII code:	ESC	W	n
Decimal:	27	87	<i>n</i>
Hexadecimal:	1B	57	<i>n</i>

Comments:

Doubles the width of all characters.  
 The following values can be used for n:  
 1: Turns mode on.  
 0: Turns mode off.

**DC4** **Cancel Double-width Mode (one line)**

---

Format:

ASCII code:	DC4
Decimal:	20
Hexadecimal:	14

Comments:

Cancels double-width mode selected by SO or ESC SO, but not double-width mode selected by ESC W or ESC !.

**ESC w****Turn Double-height Mode On/Off****Format:**

<b>ASCII code:</b>	ESC		n
<b>Decimal:</b>	27	119	n
<b>Hexadecimal:</b>	<b>1B</b>	<b>77</b>	<i>n</i>

**Comments:**

Doubles the height of all characters.

The following values can be used for n:

1: Turns mode on.

0: Turns mode off.

Doubles the height of all characters. You may need to adjust line spacing to compensate for the height of these characters.

Cannot be used with the pull tractor.

**Print Enhancement****ESC E****Select Emphasized Mode****Format:**

<b>ASCII code:</b>	ESC	E
<b>Decimal:</b>	27	69
<b>Hexadecimal:</b>	1B	45

**Comments:**

Makes text bolder by printing each dot twice, with the second dot printed slightly to the right of the first.

**ESC F****Cancel Emphasized Mode****Format:**

<b>ASCII code:</b>	ESC	F
<b>Decimal:</b>	27	70
<b>Hexadecimal:</b>	1B	46

**Comments:**

Cancels the emphasized mode selected by ESC E.

**9-28 Command Summary**

**ESC G****Select Double-strike Mode**

---

**Format:**

ASCII	code:	ESC	G
Decimal:		27	71
Hexadecimal:		1B	47

**Comments:**

Makes text bolder by printing each line twice.

**ESC H****Cancel Double-strike Mode**

---

**Format:**

ASCII	code:	ESC	H
Decimal:		27	72
Hexadecimal:		1B	48

**Comments:**

Cancels the double-strike mode selected by ESC G.

**ESC S0****Select Superscript Mode**

---

**Format:**

<b>ASCII</b>	<b>code:</b>	<b>Esc</b>	<b>S</b>	<b>0</b>
<b>Decimal:</b>		27	83	0
Hexadecimal:		1B	53	00

**Comments:**

Prints characters about two-thirds of the normal character height in the upper part of the character space.

**ESC S1**

**Select Subscript Mode**

---

Format:

ASCII code:	<b>ESC</b>	<b>S</b>	<b>1</b>
<b>Decimal:</b>	27	83	1
Hexadecimal:	1B	53	01

Comments:

Prints characters about two-thirds of the normal character height in the lower part of the character space.

**ESC T**

**Cancel Superscript/Subscript Mode**

---

Format:

ASCII code:	ESC	T
Decimal:	27	84
Hexadecimal:	1B	54

Comments:

Cancels either superscript or subscript.

ESC (-	Select Score
--------	--------------

## Format:

ASCII code:	ESC	(	-	n1	n2	m	<i>d1</i>	<i>d2</i>
Decimal:	27	40	45	<i>n1</i>	<i>n2</i>	<i>m</i>	<i>d1</i>	<i>d2</i>
Hexadecimal:	1B	28	2D	n1	n2	m	<i>d1</i>	<i>d2</i>

## Comments:

Use decimal or hexadecimal values for all variables, not ASCII characters.

Use the following values for the first 3 variables:

*n1* must be 3.

*n2* must be 0.

*m* must be 1.

The value of *d1* determines the location of the score:

*d1* = 1 for underline.

*d2* = 2 for strike-through.

*d2* = 3 for overscore.

The value of *d2* determines whether the score line is single, double, broken, or continuous:

*d2* = 0 Cancel the score line selected by *d1*.

*d2* = 1 Single continuous line.

*d2* = 2 Double continuous line.

*d2* = 5 Single broken line.

*d2* = 6 Double broken line.

**ESC -****Turn Underline Mode On/Off**

---

## Format:

ASCII code:	ESC	-	n
Decimal:	27	45	n
Hexadecimal:	1B	2D	n

## Comments:

This mode provides continuous underlining including spaces.

The following values can be used for n:

1: Turns mode on.

0: Turns mode off.

Areas skipped with HT or ESC \$ are not underlined.

**ESC q****Select Character Style**

---

## Format:

ASCII code:	ESC	q	n
Decimal:	27	113	n
Hexadecimal:	1B	71	n

## Comments:

The following values can be used for n:

0: Selects normal.

1: Selects outline.

2: Selects shadow.

3: Selects outline with shadow.

This command is valid for all characters, with the exception of character codes BOH to DFH, F4H, and F5H (176 to 223, 244, and 245 decimal) in the graphics character sets.



# Word Processing

## ESC a

## Select Justification

---

Format:

ASCII code:	ESC	a	n
Decimal:	27	97	<i>n</i>
Hexadecimal:	1B	61	<i>n</i>

Comments:

Sets the type of justification.

The following values can be used for n:

0: Selects left justification.

1: Selects centering.

2: Selects right justification.

3: Selects full justification.

The default setting is  $n = 0$ . Full justification ( $n = 3$ ) is performed when the buffer becomes full; HT and BS are invalid except in  $n = 0$  mode. For  $n = 3$  there must be no carriage returns within a paragraph.

## ESC SP (space)

## Set Intercharacter Space

---

Format:

ASCII code:	ESC	SP	n
Decimal:	27	32	n
Hexadecimal:	1B	20	<i>n</i>

Comments:

Sets **the** amount of space added to the **right** of each character, in addition to the space already allowed in the design of the character. The number of dots is determined by n, which should be from 0 to 127. **Each** unit of space is 1/120th of an inch in draft mode and 1/180th of **an** inch in Letter Quality and proportional modes.

## Character Sets

### ESC t Select Character Set

---

Format:

ASCII code:	ESC	t	n
Decimal:	27	116	n
Hexadecimal:	1B	74	n

Comments:

Selects the character table used by codes 128 to 255. Selecting a graphics character set does not disable italic printing. Italic printing can still be selected by ESC 4. The following values can be used for n:

- 0: Selects the italics character set.
- 1: Selects a graphics character set.
- 2: Selects the user-defined character table and remaps user-defined **codes O-127 to 128-255**.

Overrides the function of DIP switch 1-7. Note that the value of n must equal 00 hex, 01 hex, or 02 hex.

### ESC 4 Select Italic Mode

---

Format:

ASCII code:	ESC	4
Decimal:	27	52
Hexadecimal:	1B	34

Comments:

Causes characters from the italic character set to be printed. This command is valid even if a graphics character set has been selected by ESC t or by DIP switch 1-7, but the character graphics are not italicized.

**ESC 5****Cancel Italic Mode**

## Format:

ASCII code:	ESC	5
Decimal:	27	53
Hexadecimal:	1B	35

## Comments:

Cancels the mode selected by ESC 4.

**ESC R****Select an International Character Set**

## Format:

ASCII code:	ESC	R	<i>n</i>
<i>Decimal:</i>	27	82	<i>n</i>
Hexadecimal:	1B	52	<i>n</i>

## Comments:

Selects one of the international character sets.

The following values can be used for *n*:

0 = USA	8 = Japan
1 = France	9 = Norway
2 = Germany	10 = Denmark II
3 = England	11 = Spain II
4 = Denmark I	12 = Latin America
5 = Sweden	13 = Korea
6 = Italy	64 = Legal
7 = Spain I	

Overrides the DIP switch settings of the international character set.

## User-defined Characters

See Chapter 4 for sample programs and full information on this topic.

### ESC & Define User-defined Characters

Format:

ASCII code:	ESC	&	0	<i>n1</i>	<i>n2</i>	<i>d1</i>	<i>d2</i>	<i>data</i>
Decimal:	27	38	0	<i>n1</i>	<i>n2</i>	<i>d1</i>	<i>d2</i>	<i>data</i>
Hexadecimal:	1B	26	00	<i>n1</i>	<i>n2</i>	<i>d1</i>	<i>d2</i>	<i>data</i>

Comments:

This command allows characters to be redefined in the currently selected mode.

When defining characters, DIP switch 2-5 must be set to off.

### ESC : Copy ROM to RAM

Format:

ASCII code:	ESC	:	0	<i>n</i>	<i>0</i>
Decimal:	27	58	0	<i>n</i>	<i>0</i>
Hexadecimal:	1B	3A	00	<i>n</i>	<i>00</i>

Comments:

This sequence copies the characters in ROM to RAM so that specific characters can be redefined. The variable *n* represents the font family.

0: Roman	4: Script
1: Sans Serif	5: OCR-B
2: Courier	6: OCR-A
3: Prestige	

**ESC %****Select User-defined Set**

Format:

ASCII code:	ESC	%	<i>n</i>
<i>Decimal:</i>	27	37	<i>n</i>
Hexadecimal:	1B	25	<i>n</i>

Comments:

This sequence is used to print the user-defined (download) character set. ESC & is required to define the character set. The following values can be used for *n*:

0: Selects the normal set.

1: Selects the user-defined set.

**ESC 6****Enable Printable Characters**

Format:

ASCII code:	ESC	6
Decimal:	27	54
Hexadecimal:	1B	36

Comments:

When a graphics character set is selected, ESC 6 enables the printing of codes 128 through 159 (decimal) as characters, not control codes. See the Appendix for characters printed.

**ESC 7****Enable Upper Control Codes**

Format:

ASCII code:	ESC	7
Decimal:	27	55
Hexadecimal:	1B	37

Comments:

When a graphics character set is selected, ESC 7 causes codes 128 through 159 to be treated as control codes. This is the default.

## Graphics

See Chapter 4 for sample graphics programs. See the table under ESC\* for graphics modes.

### ESC K Select Single-density Graphics Mode

#### Format:

ASCII code:	ESC	K	<i>n1</i>	<i>n2</i>
<i>Decimal:</i>	27	75	<i>n1</i>	<i>n2</i>
Hexadecimal:	1B	4B	<i>n1</i>	<i>n 2</i>

#### Comments:

Turns on 8-pin, single-density graphics mode. The total number of columns =  $n1 + (n2 \times 256)$ .

### ESC L Select Double-density Graphics Mode

#### Format:

ASCII code:	ESC	L	<i>n1</i>	<i>n2</i>
<i>Decimal:</i>	27	76	<i>n1</i>	<i>n2</i>
Hexadecimal:	1B	4C	<i>n1</i>	<i>n 2</i>

#### Comments:

Turns on 8-pin, low-speed, double-density graphics mode. The total number of columns =  $n1 + (n2 \times 256)$ .

### ESC Y Select High-speed Double-density Graphics Mode

#### Format:

ASCII code:	ESC	Y	<i>n1</i>	<i>n 2</i>
<i>Decimal:</i>	27	89	<i>n1</i>	<i>n2</i>
Hexadecimal:	1B	59	<i>n1</i>	<i>n2</i>

#### Comments:

Turns on 8-pin, high-speed, double-density graphics mode. The total number of columns =  $n1 + (n2 \times 256)$ .

## ESC Z Select Quadruple-density Graphics Mode

---

**Format:**

<b>ASCII code:</b>	<b>ESC</b>	<b>Z</b>	n1	n2
<b>Decimal:</b>	27	90	n1	n2
<b>Hexadecimal:</b>	<b>1B</b>	<b>5A</b>	n1	n2

**Comments:**

Turns **on** 8-pin, quadruple-density graphics mode. The total number of columns =  $n1 + (n2 \times 256)$ .

## ESC\* Select Graphics Mode

---

**Format:**

<b>ASCII code:</b>	<b>ESC</b>	<b>*</b>	m	n1	n 2
<b>Decimal:</b>	27	42	m	n1	n2
<b>Hexadecimal:</b>	<b>1B</b>	<b>2A</b>	m	n1	n 2

**Comments:**

Turns on graphics mode m. See the following table for details on the available modes. The total number of columns =  $n1 + (n2 \times 256)$ .

Option	Pins	m	Horiz. density (dots/in)
Single-density	8	0	60
Doubledensity	8	1	120
High-speed double-density'	8	2	120
Quadruple-density*	8	3	240
CRT I	8	4	80
CRT II	8	6	90
Single-density	24	32	60
Double-density	24	33	120
CRT III	24	38	90
Triple-density	24	39	180
Hex-density'	24	40	360

- Adjacent dots cannot be printed in this mode.

**ESC ?****Reassign Graphics Mode**

---

**Format:**

<b>ASCII code:</b>	<b>ESC</b>	<b>?</b>	<b>s</b>	<b>m</b>
Decimal:	27	63	s	m
Hexadecimal:	1B	3F	s	m

**Comments:**

Changes from one graphics mode to another. The **variable s is a character (K, L, Y or Z).**

The variable m corresponds to the mode m in the ESC \* command.



# Appendix

Proportional Width Table .....	A-2
Character Sets. ....	A-6

# Proportional Width Table

This table lists the widths of your printer's proportional characters. The values given are in 360ths of an inch. (For example, a value of 36 is 36/360ths of an inch.) You **may** need to enter these widths into a special table for your processing program so it can calculate the number of proportional characters that will fit on a line.

The characters with no code indicated are international characters or graphics. See the table in Chapter 3 for the relevant codes for the international characters. Also, see the descriptions of the ESC R and ESC t commands in Chapter 9 for information on how to use these characters.

The following width table shows each character, its ASCII code (hexadecimal), and its width. If there are two numbers in the width column, the second **one** is for the superscript/subscript version of the character.

Code	CHR	Width
20		30/20
21	!	18/12
22	"	30/20
23	#	30/20
24	\$	30/20
25	X	36/24
26	&	36/24
27	'	18/12
28	(	24/16
<b>29</b>	)	24/16
2A	*	30/20
2B	t	30/20
2C	,	18/12
2D	-	30/20
2E	.	18/12
2F	;	30/20

Code	CHR	Width
30	<b>0</b>	30/20
31	<b>1</b>	30/20
32	<b>2</b>	30/20
33	<b>3</b>	30/20
34	<b>4</b>	30/20
35	<b>5</b>	30/20
36	<b>6</b>	30/20
37	<b>7</b>	30/20
38	<b>8</b>	30/20
<b>39</b>	<b>9</b>	<i>30/20</i>
3A	:	18/12
3B	;	18/12
3C	<	30/20
3D	=	30/20
3E	>	<i>30/20</i>
3F	?	<i>30/20</i>

Code	CHR	Width
40	@	36/24
41	A	36/24
42	B	36/24
43	C	36/24
44	D	36/24
45	E	36/24
46	F	36/24
47	G	36/24
48	H	36/24
49	I	24/16
4A	J	30/20
4B	K	36/24
4C	L	36/24
4D	M	42/28
4E	N	36/24
4F	O	36/24
50	P	36/24
51	Q	36/24
52	R	36/24
53	S	36/24
54	T	36/24
55	U	42/28
56	V	36/24
57	W	42/28
58	X	36/24
59	Y	36/24
5A	Z	30/20
5B	[	24/16
5C	\	30/20
5D	]	24/16
5E		30/20
5F	^	30/20
60		18/12
61	a	30/20
62	b	36/24
63	c	30/20

Code	CHR	Width
64	d	36/24
65	e	30/20
66	f	24/16
67	g	36/24
68	h	36/124
69	i	18/12
6A	j	24/16
6B	k	36/24
6C	l	18/12
6D	m	42/28
6E	n	36/24
6F	o	30/20
70	p	36/24
71	q	36/24
72	r	30/20
73	s	30/20
74	t	24/16
75	u	36/24
76	v	36/24
77	w	42/28
78	x	30/20
79	y	36/24
7A	z	30/20
7B	{	24/16
7c		18/12
7D	}	24/16
7E		30/20
	Ç	36/24
	ü	36/24
	é	30/20
	â	30/20
	ä	30/20
	à	30/20
	ã	30/20
	ç	30/20
	ê	30/20

Code	CHR	Width
	ë	30/20
	è	30/20
	ï	18/12
	î	18/12
	ì	18/12
	À	36/24
	Á	36/24
	É	36/24
	æ	42/28
	Æ	42/28
	ô	30/20
	ö	30/20
	ò	30/20
	û	36/24
	ù	36/24
	ÿ	36/24
	Ü	36/24
	Û	42/28
	ϕ	30/20
	£	30/20
	¥	36/24
	℞	42/28
	f	30/20
	á	30/20
	í	18/12
	ó	30/20
	ú	36/24
	ñ	36/24
	Ñ	36/24
	a	30/20
	o	30/20
	z	30/20
	~	30/20
	˘	30/20
	˙	30/20
	ı	30/20

Code	CHR	Width
	«	30/20
	»	30/20
B0	⋯	30
B1	⋯	30
B2	⋯	30
B3	—	30
B4	—	30
B5	—	30
B6	—	30
B7	—	30
B8	—	30
B9	—	30
BA	—	30
BB	—	30
BC	—	30
BD	—	30
BE	—	30
BF	—	30
co	—	30
C1	—	30
C2	—	30
C3	—	30
C4	—	30
C5	—	30
C6	—	30
C7	—	30
C8	—	30
C9	—	30
CA	—	30
CB	—	30
CC	—	30
CD	—	30
CE	—	30
CF	—	30
D0	—	30
D1	—	30
D2	—	30

Code	CHR	Width
D3	⌚	30
D4	⌚	30
D5	⌚	30
D6	⌚	30
D7	⌚	30
D8	⌚	30
D9	⌚	30
DA	⌚	30
DB	■	30
DC	■	30
DD	■	30
DE	■	30
DF	■	30
E0	α	30/20
E1	β	30/20
E2	Γ	30/20
E3	π	30/20
E4	Σ	30/20
E5	σ	30/20
E6	μ	30/20
E7	τ	30/20
E8	φ	30/20
E9	θ	30/20
EA	Ω	30/20
EB	δ	30/20
EC	θ	30/20
ED	ø	30/20
EE	ε	30/20
EF	∩	30/20
F0	≡	30
F1	⌚	30
F2	⌚	30
F3	⌚	30
F4	⌚	30
F5	⌚	30
F6	⌚	30
F7	⌚	30

Code	CHR	Width
F8	•	30
F9	•	30
FA	•	30
FB	√	30
FC	n	30
FD	z	30
FE	■	30
	•	24/16
	α	30/20
	β	36/24
	∅	36/24
	ø	30/20
	∴	30/20
	§	30/20
	¶	42/28
	'	18/12
	"	30/20
	¶	30/20
	⊙	36/24
	⊙	36/24
	†	30/20
	¶	36/24

# Character Sets

The italics character set or a graphics character set is selected by DIP switch 1-7 or the ESC t software command.

The graphics character sets are selected by DIP switches 1-1, 1-2, and 1-3 when DIP switch 1-7 is on. For the graphics character sets, the ESC 6 or ESC 7 software command lets you select whether to print hex codes 80 to 9F as characters (ESC 6) or control codes (ESC 7).

## Italic Character Set

CODE	0	1	2	3	4	5	6	7	8	9	A	B	C	D	E	F
0			0	@	P	'	p				0	@	P	'	p	
1		!	1	A	Q	a	q			!	1	A	Q	a	q	
2		"	2	B	R	b	r			"	2	B	R	b	r	
3		#	3	C	S	c	s			#	3	C	S	c	s	
4		\$	4	D	T	d	t			\$	4	D	T	d	t	
5		%	5	E	U	e	u			%	5	E	U	e	u	
6		&	6	F	V	f	v			&	6	F	V	f	v	
7		'	7	G	W	g	w			'	7	G	W	g	w	
8		(	8	H	X	h	x			(	8	H	X	h	x	
9		)	9	I	Y	i	y			)	9	I	Y	i	y	
A		*	:	J	Z	j	z			*	:	J	Z	j	z	
B		+	;	K	[	k	{			+	;	K	[	k	{	
C		,	<	L	\	l	!			,	<	L	\	l	!	
D		-	=	M	]	m	}			-	=	M	]	m	}	
E		.	>	N	^	n	~			.	>	N	^	n	~	
F		/	?	O	_	o				/	?	O	_	o		

# Graphics Character Sets

## PC 437 (United States&Epson Extended Graphics)

code	0	1	2	3	4	5	6	7	8	9	A	B	C	D	E	F
0				0	@	P	`	p	Ç	É	á		L	⌈	α	≡
1			!	1	A	Q	a	q	Û	Æ	í		⌋	⌋	β	±
2			"	2	B	R	b	r	é	Æ	ó		⌋	⌋	Γ	∓
3			#	3	C	S	c	s	â	ø	ú		⌋	⌋	Π	∓
4			\$	4	D	T	d	t	ä	ö	ñ		⌋	⌋	Σ	∓
5		§	%	5	E	U	e	u	à	ò	Ñ		⌋	⌋	σ	∓
6			&	6	F	V	f	v	á	ó	á		⌋	⌋	μ	∓
7			'	7	G	W	g	w	ç	ù	ò		⌋	⌋	τ	∓
8			(	8	H	X	h	x	ê	ÿ	ï		⌋	⌋	θ	∓
9			)	9	I	Y	i	y	ë	ÿ	ü		⌋	⌋	ø	∓
A			*		J	Z	j	z	è	ÿ	ü		⌋	⌋	Ω	∓
B			+		K	[	k	{	é	ÿ	ü		⌋	⌋	δ	∓
C			,		L	\	l	}	è	ÿ	ü		⌋	⌋	δ	∓
D			-		M	]	m	~	è	ÿ	ü		⌋	⌋	ø	∓
E			.		N	^	n		è	ÿ	ü		⌋	⌋	ø	∓
F			/		O	_	o		è	ÿ	ü		⌋	⌋	ø	∓

## PC 850 (Multilingual)

CODE	0	1	2	3	4	5	6	7	8	9	A	B	C	D	E	F
0				0	@	P	`	p	Ç	É	á		L	ø	ó	—
1			!	1	A	Q	a	q	Û	Æ	í		⌋	ø	ó	±
2			"	2	B	R	b	r	é	Æ	ó		⌋	ø	ó	±
3			#	3	C	S	c	s	â	ø	ú		⌋	ø	ó	±
4			\$	4	D	T	d	t	ä	ö	ñ		⌋	ø	ó	±
5		§	%	5	E	U	e	u	à	ò	Ñ		⌋	ø	ó	±
6			&	6	F	V	f	v	á	ó	á		⌋	ø	ó	±
7			'	7	G	W	g	w	ç	ù	ò		⌋	ø	ó	±
8			(	8	H	X	h	x	ê	ÿ	ï		⌋	ø	ó	±
9			)	9	I	Y	i	y	ë	ÿ	ü		⌋	ø	ó	±
A			*		J	Z	j	z	è	ÿ	ü		⌋	ø	ó	±
B			+		K	[	k	{	é	ÿ	ü		⌋	ø	ó	±
C			,		L	\	l	}	è	ÿ	ü		⌋	ø	ó	±
D			-		M	]	m	~	è	ÿ	ü		⌋	ø	ó	±
E			.		N	^	n		è	ÿ	ü		⌋	ø	ó	±
F			/		O	_	o		è	ÿ	ü		⌋	ø	ó	±

### PC 860 (Portugal)

CODE	0	1	2	3	4	5	6	7	8	9	A	B	C	D	E	F
0				0	@	P	`	p	Ç	É	á	í	ó	l	l	α
1			!	1	A	Q	a	q	ú	Ê	ê	ó	l	l	β	
2			"	2	B	R	b	r	é	Ë	ë	ó	l	l	Γ	
3			#	3	C	S	c	s	â	È	è	ó	l	l	Π	
4			\$	4	D	T	d	t	ã	É	é	ó	l	l	Σ	
5	§		%	5	E	U	e	u	ä	Ò	ò	ó	l	l	Ω	
6			&	6	F	V	f	v	å	Ó	ó	ó	l	l	μ	
7			'	7	G	W	g	w	æ	Ô	ô	ó	l	l	τ	
8			(	8	H	X	h	x	ç	Ï	ï	ó	l	l	ϑ	
9			)	9	I	Y	i	y	ê	Ö	ö	ó	l	l	θ	
A			*	A	J	Z	j	z	ë	Ü	ü	ó	l	l	Ω	
8			+	8	K	[	k	{	í	½	½	ó	l	l	δ	
C			,	C	L	\	l		ô	¼	¼	ó	l	l	σ	
D			-	D	M	]	m	~	í	¾	¾	ó	l	l	σ	
E			=	E	N	^	n		í	¾	¾	ó	l	l	ε	
F			/	F	O	_	o	~	í	¾	¾	ó	l	l	ε	

### PC 863 (Canada-French)

CODE	0	1	2	3	4	5	6	7	8	9	A	B	C	D	E	F
0				0	@	P	`	p	Ç	É	í	ó	l	l	α	
1			!	1	A	Q	a	q	ú	Ê	ê	ó	l	l	β	
2			"	2	B	R	b	r	é	Ë	ë	ó	l	l	Γ	
3			#	3	C	S	c	s	â	È	è	ó	l	l	Π	
4			\$	4	D	T	d	t	ã	É	é	ó	l	l	Σ	
5	§		%	5	E	U	e	u	ä	Ò	ò	ó	l	l	Ω	
6			&	6	F	V	f	v	å	Ó	ó	ó	l	l	μ	
7			'	7	G	W	g	w	æ	Ô	ô	ó	l	l	τ	
8			(	8	H	X	h	x	ç	Ï	ï	ó	l	l	ϑ	
9			)	9	I	Y	i	y	ê	Ö	ö	ó	l	l	θ	
A			*	A	J	Z	j	z	ë	Ü	ü	ó	l	l	Ω	
B			+	B	K	[	k	{	í	½	½	ó	l	l	δ	
C			,	C	L	\	l		ô	¼	¼	ó	l	l	σ	
D			-	D	M	]	m	~	í	¾	¾	ó	l	l	σ	
E			=	E	N	^	n		í	¾	¾	ó	l	l	ε	
F			/	F	O	_	o	~	í	¾	¾	ó	l	l	ε	



PC 865 (Norway)

CODE	0	1	2	3	4	5	6	7	8	9	A	B	C	D	E	F
0				0	@	P	`	p	Ç	É	á	☐	L	l	a	≡
1			!	1	A	Q	a	q	ú	æ	í	☐	+	+	β	±
2			"	2	B	R	b	r	é	Æ	ó	☐	-	-	Γ	∇
3			#	3	C	S	c	s	á	ø	ú	☐			Π	∇
4			\$	4	D	T	d	t	ä	ö	ñ	☐			Σ	∇
5		§	%	5	E	U	e	u	à	ò	Ñ	☐	+	+	Ο	∇
6			&	6	F	V	f	v	å	å	Ω	☐	-	-	μ	∇
7			'	7	G	W	g	w	ç	ù	Ω	☐	-	-	τ	∇
8			(	8	H	X	h	x	ë	ÿ	Ω	☐	-	-	ϑ	∇
9			)	9	I	Y	i	y	è	ÿ	Ω	☐	-	-	θ	∇
A			*		J	Z	j		è	ÿ	Ω	☐	-	-	ϑ	∇
B			+	:	K	[	k	{	è	ÿ	Ω	☐	-	-	ϑ	∇
C			,	;	L	\	l		è	ÿ	Ω	☐	-	-	ϑ	∇
D			=	<	M	]	m	}	è	ÿ	Ω	☐	-	-	ϑ	∇
E			-	>	N	^	n	~	è	ÿ	Ω	☐	-	-	ϑ	∇
F			.	?	O	_	o	~	è	ÿ	Ω	☐	-	-	ϑ	∇
			/						è	ÿ	Ω	☐	-	-	ϑ	∇

# Glossary

Note that these definitions apply specifically to printers. If a word is italicized, see that topic for more information.

## **application program**

A software program **that** helps you carry out a particular task, such as word processing or financial planning.

## **ASCII**

Acronym for the American Standard Code for Information Interchange. A standardized coding system for assigning numerical codes to letters and symbols.

## **auto line feed**

When this feature is enabled using a DIP switch or external control through the parallel connector, the printer will automatically feed the paper one line after receiving a CR code.

## **baud rate**

A measure of the speed of data transmission. Usually expressed in bits per second or bps.

## **bidirectional printing**

Printing in which the print head alternates printing a line left to right then **the** next line right to left, and so **on**. Because the head prints in both directions, the overall printing speed increases by eliminating wasted (non-printing) movement.

## **binary**

*See number systems.*

## **bit**

A binary digit (0 or 1), which is the smallest unit of information used by a printer or computer. See also *number systems*.

## **buffer**

*See input buffer* and memory.

**byte**

A unit of information consisting of eight bits.

**carriage return (CR)**

The control code that returns the print position to the left margin. When issued together with a line feed, the print position moves to the left margin of the next line. In bidirectional printing, the print head may not physically move to the left margin.

**character set**

A collection of letters, numbers, and symbols that provides you with the characters used in a particular language.

**code page tables**

*See graphics character sets.*

**condensed**

Printing in which each character is approximately 60 percent of the width of standard characters. For example, condensed 10 characters per inch (cpi) has 17 characters per inch. Useful for fitting wide tables or spreadsheets onto the paper.

**continuous paper**

Paper which has sprocket-feed holes on both long edges, is perforated between pages, and is supplied in a folded stack. Also called fanfold paper.

**control code**

In addition to the codes for printable characters, the ASCII standard also includes 33 other codes which are called control codes. These control codes perform such functions as sounding the beeper and performing a carriage return or line feed.

**cut sheet feeder (CSF)**

An optional, detachable device which automatically feeds single sheets of paper into the printer.

**data dump**

Sometimes called hex dump. A troubleshooting feature. When the printer is in the data dump mode, each code that it receives is printed in hexadecimal notation.

**decimal**

*See number systems.*

**default**

A value or setting that takes effect when the equipment is turned on, reset, or initialized.

**DIP switches**

Small switches in a printer that control various printer functions and set the default status of the printer when it is turned on or initialized. DIP stands for Dual In-line Package.

**dot graphics**

A graphic design formed by patterns of dots. Also called bit image graphics.

**dot matrix**

A method of printing in which each letter or symbol is formed by a pattern (matrix) of individual dots.

**double-height printing**

Printing in which each character is twice as tall as normal.

**double-strike printing**

A way of producing bolder characters. Each character is printed twice. Can only be used in draft mode.

**double-width printing**

A **print** width in which each character is twice as wide as normal characters. (The cpi is halved.)

**draft mode**

One of two print qualities available on your printer. Draft uses fewer dots per character for high-speed printing. See also *Letter Quality*.

**emphasized printing**

A way of producing darker characters. In a single pass of the print head, characters receive twice the number of dots.

**ESC (escape) code**

A special control code used to begin most printer commands.

**ESC/P**

Abbreviation for Epson Standard Code for Printers. The system of commands lets you perform software control of your printer from your computer. It is standard for all Epson printers and supported by most application software for personal computers.

**font**

A font is a style of type designated by a family name.

**form**

In printer terminology, a form normally refers to a page.

**form feed**

Refers to both a control code and a panel button that advances the paper to the top of the next page.

**graphics character sets**

The graphics character sets contain international accented characters, Greek characters, and character graphics for printing lines, comers, and shaded areas. Also called code page tables.

**hexadecimal (hex)**

*See number systems.*

**initialize**

To establish the initial default status of the printer by turning the printer on or by sending an INIT signal or code.

**input buffer**

The memory in the printer in which data sent from the computer is stored while waiting to be printed.

**interface**

The means of connection between the computer and printer. See also *parallel interface* and *serial interface*.

**italic**

A typeset in which the characters slant. *This sentence is italicized.*

**Letter Quality**

One of two print qualities available on your printer. Letter Quality provides better readability and appearance at a reduced print speed. See also *draft mode*.

**line feed**

Both a control code and a panel button that advances the paper one line space.

**loading position**

The position to which the paper is automatically loaded. It can be adjusted by using the micro-adjustment feature.

**memory**

The printer, like a computer, has a memory. When you print a file from a computer, the contents of the file are transferred quickly from the computer's memory to the printer's memory. The printer then prints information from its own memory at a much slower rate. This way of printing frees the computer to do other work while the printer is still working. The printer memory is sometimes called the buffer memory or input buffer.

**micro-adjustment**

A feature that adjusts the paper loading and short tear-off positions by the smallest possible increments.

## **number systems**

Three number systems are commonly used with printers:

**binary** is base 2 and uses only the digits 0 and 1. All information in computer systems is handled in binary form represented by electrical signals that are on or off. A binary digit is often called a bit; any decimal number between 0 and 255 can be expressed by an eight-bit binary number.

**decimal** is base 10 and uses the digits 0, 1, 2, 3, 4, 5, 6, 7, 8, and 9. (This is the most familiar system.)

**hexadecimal** (hex) is base 16 and uses the digits 0, 1, 2, 3, 4, 5, 6, 7, 8, 9, A, B, C, D, E, and F. This is frequently used by programmers. Any decimal number between 0 and 255 can be expressed by a two-digit hex number.

## **on line**

When the printer is on line, it is able to communicate with the computer connected to it.

## **paper-out sensor**

A small switch behind the platen that sends a signal **when** it is **not** in contact with paper, informing the printer and remote computer that there is no paper loaded, and causing the **PAPER OUT** light to go on.

## **paper tension unit**

The part of the printer that fits above the platen to assure proper paper tension in the printing area.

## **parallel interface**

An interface that connects the computer and the printer. A parallel interface transmits data one character or code at a time. See also *serial interface*.

## **platen**

The black roller that provides the backing for the paper during printing.

**print quality**

Your printer has two types of print quality; draft and Letter Quality. Draft is for high-speed, draft quality jobs; Letter Quality is used to produce more polished documents.

**proportional printing**

Printing in which the character width varies from character to character. For example, a capital W receives much more space than a lowercase i. The result looks more like a typeset book than a typewritten draft.

**pull tractor unit**

An optional device that feeds continuous paper and multi-part forms through the printer.

**push tractor**

A built-in device that feeds continuous paper through the printer.

**RAM**

Acronym for Random Access Memory. The portion of the printer's memory used as a buffer and as a place for storing user-defined characters. All data stored in RAM is lost when the printer is turned off.

**reset**

To return a printer to its defaults, either by a command, an INIT signal, code, or by turning the printer off and on.

**ROM**

Acronym for Read Only Memory. The portion of the printer's memory used to store power-on instructions and built-in fonts.

**self test**

A method of checking the operation of the printer. When the self test is run, the printer prints out its current DIP switch settings and the characters that are stored in its ROM.

**serial interface**

A serial interface transmits data one bit at a time. See also parallel interface.



**short tear-off**

A feature that automatically feeds the perforation of continuous paper to the tear-off position to be removed by the operator, and then draws the paper back to the loading position. These positions can be adjusted using the micro-adjustment feature. See also micro-adjustment and loading position.

**10 cpi**

A character spacing of 10 characters per inch. This is often the standard or default pitch.

**tractor**

The part of the printer that moves continuous paper through the printer by its sprockets gripping the holes in continuous paper.

**12 cpi**

A character spacing in which each character is slightly narrower than normal, so that there are 12 characters per inch.

**unidirectional printing**

Printing in one direction only. Allows more precise vertical alignment than bidirectional printing. Often used for printing graphics.

**user-defined characters**

Characters that are defined and stored in the printer by the user. Also known as downloaded characters.

# Index

Command descriptions are not indexed here. To locate the page number of a specific command, see Chapter 9 or the Quick Reference card.

## A

### Application

- programs, 3-6
- software, 1-25

Assembling printer, 1-7-14

Auto line feed, 3-14

## B

Bidirectional printing, 3-12,  
3-14, 8-2

Built-in fonts, 3-6—10

## C

### Character

- defining, 4-19—21
- designing, 4-17—28
- fonts, 3-6—10, 8-3
- size, 4-3—4
- spacing, 3-13, 4-2—3

Character sets, A-6—9

- choosing, 3-24—25, 9-34

Cleaning printer, 6-2—3

Code page tables, 3-13, 3-25  
see also Graphics character  
sets

Command summary, 9-1—40

CONDENSED button, 3-4,

Condensed mode, 3-10, 4-4,  
9-25—26

Connecting printer, 1-22—24

Consumer Information number,  
Intro-6

### Continuous paper

- loading, 2-8—15
- switching to single sheets,  
2-16—22
- using, 2-8—15

Control keys, 9-4

Control panel, 3-2—5

- buttons, 3-3
- features, 3-5
- lights, 3-2

Copies, number of, 8-6

Courier font, 3-8

Cut sheet feeder, 5-2—23

- inserting single sheets,  
5-12—13

installation, 5-2—5

paper handling, 5-6—9

removing, 5-22—23

self test, 5-9—11

specifications, 8-13—14

switching to push tractor,  
5-15—22

testing printer, 5-9—11

using continuous paper with,  
5-15—22

using control panel, 5-14

using software, 5-14—15

## D

- Data dump, 3-26—27
- Default settings, initialization, 8-15—16
- Design grids, 4-18—19
- Dimensions, printer, 8-8
- DIP switches
  - settings, 3-11—14
  - tables, 3-12—13
- Dot graphics mode, 4-7—16
- Dot patterns, 4-8—9
- Double-height mode, 4-3—4, 9-28
- Double-strike printing, 4-4—5, 9-29
- Double-width mode, 4-3—4, 9-26—27
- Draft
  - font, 3-8
  - printing, 9-22

## E

- Electrical specifications, 8-8
- Emphasized printing, 4-4—5, 9-28
- Enabled/disabled signals, 8-12
- Envelopes, 2-25, 2-28—30, 8-4, 8-6—7
- Environment specifications, 8-8
- Epson Extended Graphics, 3-13, 3-25, A-7

## F

- Film ribbon cartridges, 2-24—25, 6-4
- FONT button, 3-4, 3-6
- FORM FEED button, 3-3

## G

- Graphics, 4-1—28
  - character sets, 3-13, 3-24—25, A-7—9
  - designing, 4-13—16
  - mode command, 4-11, 9-39

## H

- Help, Intro-6

## I

- IEEE-488 interfaces, 5-37
- Initialization
  - default settings, 8-15—16
  - specifications, 8-15—16
- Input buffer, 3-14, 8-3
- Interface boards, 5-37—46
  - #8143 interface, 5-46
  - choosing, 5-37
  - compatible, 5-38
  - installation, 5-38—45
- Interface specifications, 8-9—12
- International character sets, 3-13, 3-22—23, 9-35
- Italic
  - character set, 3-24—25, A-6
  - printing, 4-5, 9-34—35

## L

- Labels, 2-25, 2-27—28, 8-4, 8-6—7
- Letter Quality
  - characters, 4-26—27
  - fonts, 3-10
  - printing, 9-22
- LINE FEED button, 3-3
- Line spacing, 8-2
- LOAD/EJECT button, 3-3
- Loading position, adjusting, 3-17—18
- Locking clip, 1-4, 6-11

## M

- Maintaining printer, 6-1—11
- Mechanical specifications, 8-7—8
- Micro-adjustment, 3-17—18
- Multi-part forms, 2-25—27, 8-6—7
- MULTI-PART light, 3-2, 3-18

## O

- OCR-A font, 3-9
- OCR-B font, 3-9
- ON LINE
  - button, 3-3
  - light, 3-2
- Options
  - problems and solutions, 7-10—11
  - specifications, 8-13—14
- Orator font, 3-9
- Orator-S font, 3-10

- Outline printing, 4-6, 9-32
- Overlining, 4-5, 9-31

## P

- Page length, 3-15, 9-13
  - selection, 3-13
- Paper
  - length, 8-4
  - specifications, 8-3—7
  - weight, 8-6
  - width, 8-4
- Paper feeding
  - methods, 2-2—3, 8-3
  - speed, 8-2
- Paper guide, attaching, 1-13—14
- Paper handling, 2-1—30
  - problems and solutions, 7-7—9
- PARER OUT light, 3-2
- Paper release lever, 2-2—3
- Paper thickness, 8-6
  - lever, 2-23—26
  - table, 2-25
- Parallel interface, 5-37, 8-9—11
  - connecting, 1-22-24**
- Pin assignments, 8-9—11
- Pin labels, 4-9—10
- Platen knob, installing, 1-7—8
- POWER light, 3-2
- Prestige font, 3-8
- Print
  - method, 8-2
  - speed, 8-2
- Print head, 4-8—9
  - life, 8-7

## Printable area

- continuous paper, 8-5
- envelopes, 8-6
- single sheet, 8-4—5

## Printable columns, 8-2

## Printer

- assembling, 1-7—14
- cleaning, 6-2—3
- connecting to computer,  
1-22—24
- dimensions, 8-8
- location for, 1-5—6
- options, using, 5-1—46
- parts, 1-2
- specifications, 8-2—8
- stand, 1-6
- testing, 1-15—21
- transporting, 6-10—11
- unpacking, 1-2—4
- weight, 8-8

## Printing

- characters, 4-24
- direction, 3-14, 8-2
- enhancing, 4-2-6
- problems and solutions,  
7-2—6
- specifications, 8-2—3

## Problems, see Troubleshooting

## Proportional width characters, 4-26, 9-25, A-2—5

## Protective materials, removing, 1-3—4

## Pull tractor, 5-24—36

- installation, 5-24
- paper handling, 5-27—33
- removing, 5-33—36

## R

### READY light, 3-2

### Reloading paper, 2-7

### Replacement ribbons, 6-4

## Ribbon

- cartridge, installing, 1-8—13
- replacing, 6-4—9
- specifications, 8-7

### ROM characters, 4-25, 9-36

### Roman font, 3-8

## S

### Sans Serif font, 3-8

### Script font, 3-9

### SelecType, 3-4, 3-6—7

- settings, 3-6

### Self test, 1-15—21

### Serial interfaces, 5-37

### Setting up printer, 1-1—25

### Shadow printing, 4-6, 9-32

### Short tear-off, using, 3-19—21

## Single sheet paper

- loading, 2-4—7
- switching from continuous,  
2-16—22
- using, 2-4—7

### Skip over perforation, 3-12, 3-16, 9-14

### Software, 4-1—28

- commands, 9-2—40

### Special paper, 2-23—30

## Specifications

- electrical, 8-8
- environment, 8-8
- initialization, 8-15—16
- interface, 8-9—12
- options, 8-13—14
- printer, 8-2—8
- technical, 8-1—16

Standby position, 2-17

Strike-through printing, 4-5,  
9-31

Subscripts, 4-6, 4-26—27, 9-30

Superscripts, 4-6, 4-26—27, 9-29

## T

Tear-off

- mode, 3-14
- position, adjusting, 3-20—21

Technical specifications,  
8-1—16

Testing printer, 1-15—21,  
5-9—11

Thin paper, 2-25

Transporting printer, 6-10—11

Troubleshooting, 7-1—11

Typestyles, selecting, 3-6—10

## U

Underlining, 4-5, 9-31—32

Unidirectional printing, 3-12,  
3-14, 8-2, 9-9—10

Unpacking printer, 1-2—4

User-defined characters,  
4-17—28

## W

Weight, printer, 8-8

LQ-510/1010

Quick Reference

# Control and ESCape Codes by Function

The following control codes are listed briefly for quick reference. For a more detailed explanation, see the page reference in Chapter 9. Variables are not included in this quick reference due to their complexity. For those codes that contain variables, such as **as** ESC Q n for setting the right margin, see Chapter 9.

## Printer Operation

ASCII	Dec.	Hex.	Description	Page
ESC @	64	40	Initialize Printer	9-8
DC1	17	11	Select Printer	9-8
DC3	19	13	Deselect Printer	9-9
DEL	127	7F	Delete Character	9-9
ESC <	60	3C	Select Unidirectional Mode (one line)	9-9
ESC U	85	55	Turn Unidirectional Mode On/Off	9-10
ESC EM	25	19	Control Cut Sheet Feeder Mode	9-10

## MSB Control

ASCII	Dec.	Hex.	Description	Page
ESC =	61	3D	Set MSB to 0	9-11
ESC >	62	3E	Set MSB to 1	9-11
ESC #	35	23	Cancel MSB Control	9-11
BEL	7	07	Beeper	9-12

## Data Control

ASCII	Dec.	Hex.	Description	Page
CR	13	0D	Carriage Return	9-12
CAN	24	18	Cancel Line	9-12

## Vertical Motion

ASCII	Dec.	Hex.	Description	Page
FF	12	0C	Form Feed	9-13
ESC C	67	43	Set Page Length in Lines	9-13
ESC C 0	67	43	Set Page Length in Inches	9-13
ESC N	78	4E	Set Skip Over Perforation	9-14
ESC O	79	4F	Cancel Skip Over Perforation	9-14
LF	10	0A	Line Feed	9-14
ESC 0	48	30	Select 1/8-inch Line Spacing	9-15
ESC 2	50	32	Select 1/6-inch Line spacing	9-15
ESC +	43	2B	Set <i>n</i> /360-inch Line Spacing	9-15
ESC 3	51	33	Set <i>n</i> /180-inch Line Spacing	9-16
ESC A	65	41	Set <i>n</i> /60-inch Line Spacing	9-16
ESC J	74	4A	Perform <i>n</i> /180-inch Line Feed	9-16
VT	11	0B	Tab Vertically	9-17
ESC B	66	42	Set Vertical Tabs	9-17
ESC b	98	62	Set Vertical Tabs in Channels	9-18
ESC /	47	2F	Select Vertical Tab Channel	9-18



## Horizontal Motion

ASCII	Dec.	Hex.	Description	
ESC I	108	6C	Set Left Margin	9-19
ESC Q	81	51	Set Right Margin	9-19
BS	8	08	Backspace	9-20
ESC \$	36	24	Set Absolute Print Position	9-20
ESC \	92	5C	Set Relative Print Position	9-21
HT	9	09	Tab Horizontally	9-21
ESC D	68	44	Set Horizontal Tabs	9-22

## Overall Printing Style

ASCII	Dec.	Hex.	Description	Page
ESC x	120	70	Select Letter Quality or Draft	9-22
ESC k	107	6B	Select Typestyle Family	9-22
ESC l	33	21	Master Select	9-23

## Print Size and Character Width

ASCII	Dec.	Hex.	Description	Page
ESC P	80	50	Select 10 CPI	9-24
ESC M	77	4D	Select 12 CPI	9-24
ESC 9	103	67	Select 15 CPI	9-24
ESC 0	112	70	Turn Proportional Mode On/Off	9-25
SI	15	0F	Select Condensed Mode	9-25
ESC SI	15	0F	Select Condensed Mode	9-26
DC2	18	12	Cancel Condensed Mode	9-26
SO	14	0E	Select Double-width Mode (one line)	9-26
ESC SO	14	0E	Select Double-width Mode (one line)	9-27
ESC W	07	57	Turn Double-width Mode On/Off	9-27
DC4	20	14	Cancel Double-width Mode (one line)	9-27
ESC w	119	77	Turn Double-height Mode On/Off	9-28

## Print Enhancement

ASCII	Dec.	Hex.	Description	Page
ESC E	69	45	Select Emphasized Mode	9-28
ESC F	70	46	Cancel Emphasized Mode	9-28
ESC G	71	47	Select Double-strike Mode	9-29
ESC H	72	48	Cancel Double-strike Mode	9-29
ESC SO	a3	53	Select Superscript Mode	9-29
ESC S 1	83	53	Select Subscript Mode	9-30
ESC T	84	54	Cancel Superscript/Subscript Mode	9-30
ESC (-	40	28	Select Score	9-31
ESC -	45	2D	Turn Underline Mode On/Off	Text
ESC q	113	71	Select Character Style	Text

## Word Processing

ASCII	Dec.	Hex.	Description	Page
ESC a	97	61	Select Justification	9-33
ESC SP	32	20	Set Intercharacter Space	9-33

## Character Sets

ASCII	Dec.	Hex.	Description	Page
ESC t	116	74	Select Character Set	9-34
ESC 4	52	34	Select Italic Mode	9-34
ESC 5	53	35	Cancel Italic Mode	9-35
ESC R	82	52	Select an International Character Set	9-35

## User-defined Characters

ASCII	Dec.	Hex.	Description	Page
ESC &	38	26	Define User-defined Characters	9-36
ESC :	58	3A	Copy ROM to RAM	9-36
ESC %	37	25	Select User-defined Set	9-37
ESC 6	54	36	Enable Printable Characters	9-37
ESC 7	55	37	Enable Upper Control Codes	9-37

## Graphics

ASCII	Dec.	Hex.	Description	Page
ESC K	75	4B	Select Single-density Graphics Mode	9-38
ESC L	76	4C	Select Double-density Graphics Mode	9-38
ESC Y	89	59	Select High-speed Double-density	9-38
ESC Z	90	5A	Select Quadruple-density Graphics	9-39
ESC*	42	2A	Select Graphics Mode	9-39
ESC ?	63	3F	Reassign Graphics Mode	9-40



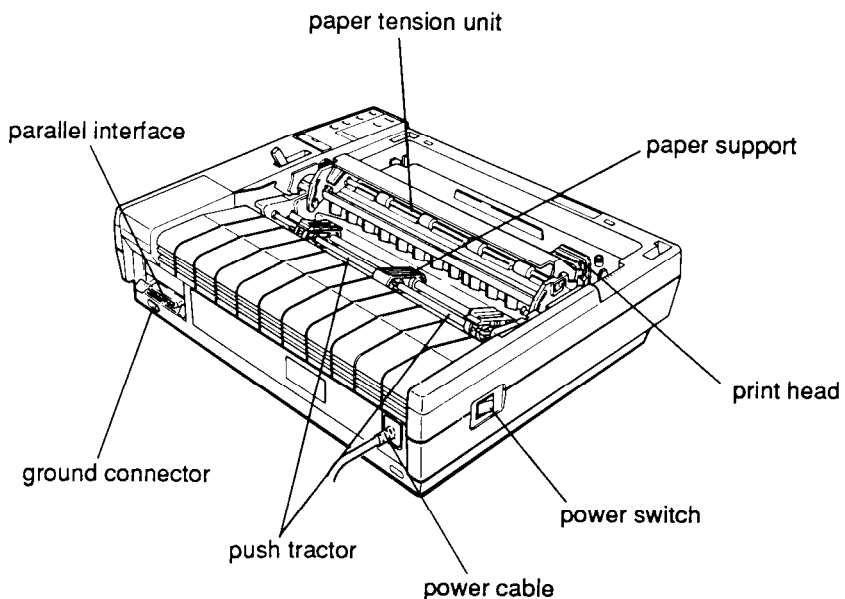
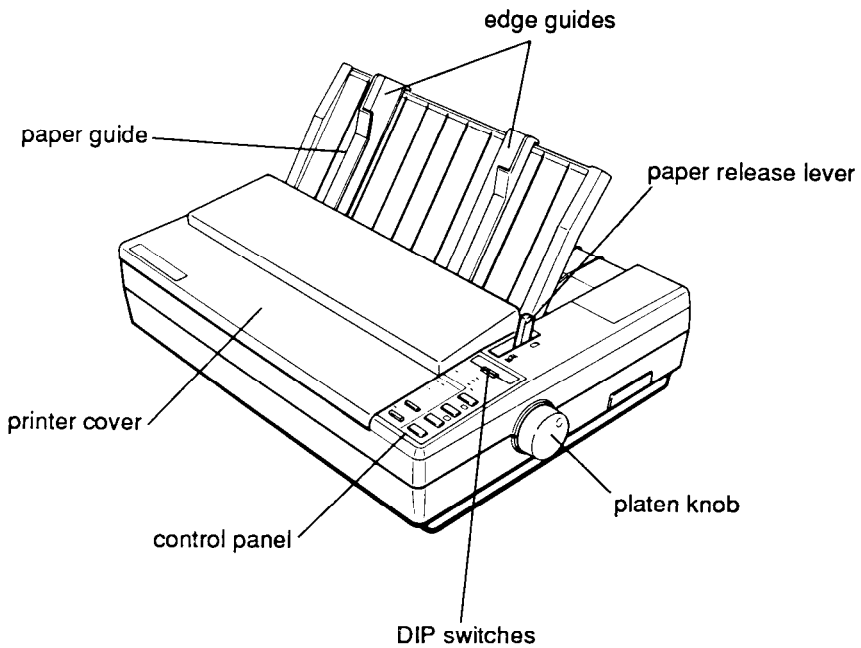

LQ-510/1010

Quick Reference

# Control and ESCape Codes by Function

The following control codes are listed briefly for quick reference. For a more detailed explanation, see the page reference in Chapter 9. Variables are not included in this quick reference due to their complexity. For those codes that contain variables, such as ESC Q n for setting the right margin, see Chapter 9.

## Printer Operation

ASCII	Dec.	Hex.	Description	Page
ESC @	64	40	Initialize Printer	9-8
DC1	17	11	Select Printer	9-8
DC3	19	13	Deselect Printer	9-9
DEL	127	7F	Delete Character	9-9
ESC <	60	3C	Select Unidirectional Mode (one line)	9-9
ESC U	85	55	Turn Unidirectional Mode On/Off	9-10
ESC EM	25	19	Control Cut Sheet Feeder Mode	9-10

## MSB Control

ASCII	Dec.	Hex.	Description	Page
ESC =	61	3D	Set MSB to 0	9-11
ESC >	62	3E	Set MSB to 1	9-11
ESC #	35	23	Cancel MSB Control	9-11
BEL	7	07	Beeper	9-12

## Data Control

ASCII	Dec.	Hex.	Description	Page
CR	13	0D	Carriage Return	9-12
CAN	24	18	Cancel Line	9-12

## Vertical Motion

ASCII	Dec.	Hex.	Description	Page
FF	12	0C	Form Feed	9-13
ESC C	67	43	Set Page Length in Lines	9-13
ESC C 0	67	43	Set Page Length in Inches	9-13
ESC N	78	4E	Set Skip Over Perforation	9-14
ESC O	79	4F	Cancel Skip Over Perforation	9-14
LF	10	0A	Line Feed	9-14
ESC 0	48	30	Select 1/8-inch Line Spacing	9-15
ESC 2	50	32	Select 1/6-inch Line Spacing	9-15
ESC +	43	2B	Set <i>n</i> /360-inch Line Spacing	9-15
ESC 3	51	33	Set <i>n</i> /180-inch Line Spacing	9-16
ESC A	65	41	Set <i>n</i> /60-inch Line Spacing	9-16
ESC J	74	4A	Perform <i>n</i> /180-inch Line Feed	9-16
VT	11	0B	Tab Vertically	9-17
ESC B	66	42	Set Vertical Tabs	9-17
ESC b	98	62	Set Vertical Tabs in Channels	9-18
ESC /	47	2F	Select Vertical Tab Channel	9-18

## Horizontal Motion

ASCII	Dec.	Hex.	Description	Page
ESC I	108	6C	Set Left Margin	9-19
ESC Q	81	51	Set Right Margin	9-19
BS	8	08	Backspace	9-20
ESC \$	36	24	Set Absolute Print Position	9-20
ESC \	92	5C	Set Relative Print Position	9-21
HT	9	09	Tab Horizontally	9-21
ESC D	68	44	Set Horizontal Tabs	9-22

## Overall Printing Style

ASCII	Dec.	Hex.	Description	Page
ESC x	120	78	Select Letter Quality or Draft	9-22
ESC k	107	6B	Select Typestyle Family	9-22
ESC !	33	21	Master Select	9-23

## Print Size and Character Width

ASCII	Dec.	Hex.	Description	Page
ESC P	80	50	Select 10 CPI	9-24
ESC M	77	4D	Select 12 CPI	9-24
ESC g	103	67	Select 15 CPI	9-24
ESC p	112	70	Turn Proportional Mode On/Off	9-25
SI	15	0F	Select Condensed Mode	9-25
ESC SI	15	0F	Select Condensed Mode	9-26
DC2	18	12	Cancel Condensed Mode	9-26
SO	14	0E	Select Double-width Mode (one line)	9-26
ESC SO	14	0E	Select Double-width Mode (one line)	9-27
ESC W	87	57	Turn Double-width Mode On/Off	9-27
DC4	20	14	Cancel Double-width Mode (one line)	9-27
ESC w	119	77	Turn Double-height Mode On/Off	9-28

## Print Enhancement

ASCII	Dec.	Hex.	Description	Page
ESC E	69	45	Select Emphasized Mode	9-28
ESC F	70	46	Cancel Emphasized Mode	9-28
ESC G	71	47	Select Double-strike Mode	9-29
ESC H	72	48	Cancel Double-strike Mode	9-29
ESC S 0	83	53	Select Superscript Mode	9-29
ESC S 1	83	53	Select Subscript Mode	9-30
ESC T	84	54	Cancel Superscript/Subscript Mode	9-30
ESC {	40	28	Select Score	9-31
ESC -	45	2D	Turn Underline Mode On/Off	9-32
ESC q	113	71	Select Character Style	9-32

## Word Processing

ASCII	Dec.	Hex.	Description	Page
ESC a	97	61	Select Justification	9-33
ESC SP	32	20	Set Intercharacter Space	9-33

EPSON AMERICA, INC. 2780 Lomita Boulevard, Torrance, California 90505

**EPSON®**