

Accolade™

Quick Guide

WIRELESS
AUDIO SET
TRANSMITTER AND RECEIVER

Contents

Welcome	3
Unpacking the Wireless Audio Set	4
Setting Up	5
Overview	5
Connecting the Audio Set Transmitter	6
Connecting the Audio Set Receiver	13
Configuring Your Epson MovieMate	17
Configuring Your DVD Player	18
Using the Wireless Audio Set	19
Powering On Your Equipment	19
Controlling Volume	20
Solving Problems	21
Wireless Audio Set Status Lights	21
Problems and Solutions	24
Help	26
Notices	27
Trademarks	31

Welcome

The Accolade™ Wireless Audio Set allows you to transmit digital audio from an Epson MovieMate™ projector to an audio system (such as a home theater system or a stereo receiver). If you don't have access to an audio system, you can use the Wireless Audio Set's built-in 15-watt amplifier to power a pair of unpowered speakers.

You can also use the Wireless Audio Set to transmit audio from a standard DVD player with an optical or coaxial audio output to an audio system or a pair of unpowered speakers. This allows you to conveniently transmit audio wirelessly to your audio system while using a projector and DVD player that are not in close proximity to your audio system.

Unpacking the Wireless Audio Set

Unpack the Wireless Audio Set, and make sure you have all the parts shown:

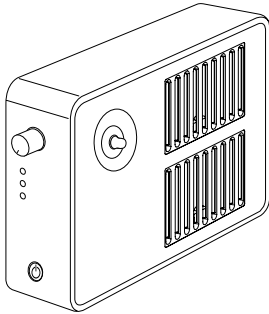

Receiver



Receiver power adapter

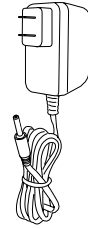

Transmitter power adapter

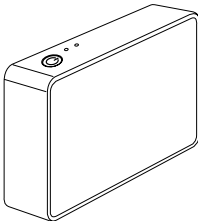

Transmitter

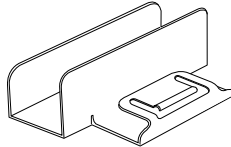

Transmitter stand

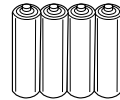

4 AA batteries

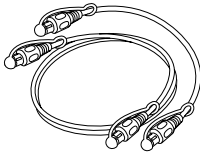

2 optical audio cables

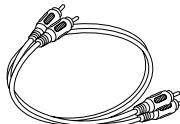

RCA cable

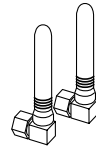

2 antennas

If anything is missing, contact technical support as described on page 26.

Setting Up

Overview

The Wireless Audio Set consists of a digital audio transmitter and receiver. To listen to audio wirelessly, you need to connect the Audio Set transmitter to your Epson MovieMate or DVD player and the Audio Set receiver to an audio system (such as a home theater system or a stereo receiver) or a pair of unpowered speakers. Refer to the illustrations below for an example of two common configurations:

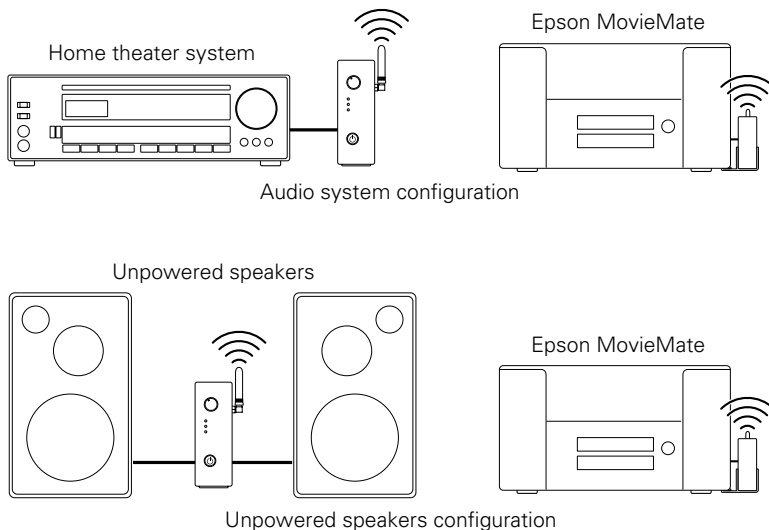

Follow the instructions in this chapter on:

- “Connecting the Audio Set Transmitter” on page 6
- “Connecting the Audio Set Receiver” on page 13
- “Configuring Your Epson MovieMate” on page 17
- “Configuring Your DVD Player” on page 18

Connecting the Audio Set Transmitter

Before you begin, make sure that your Epson MovieMate or DVD player is turned off. Then follow the steps in these sections on:

- “Attaching the Antenna” below
- “Powering the Transmitter” on page 7
- “Connecting the Transmitter’s Audio Cable” on page 9

Attaching the Antenna

1. Remove the red cap from the transmitter’s antenna connector.
2. Attach one of the included antennas to the transmitter, then hand-tighten the nut at the base of the antenna.

Caution:

Do not use a tool to tighten the nut, or you may damage the transmitter.

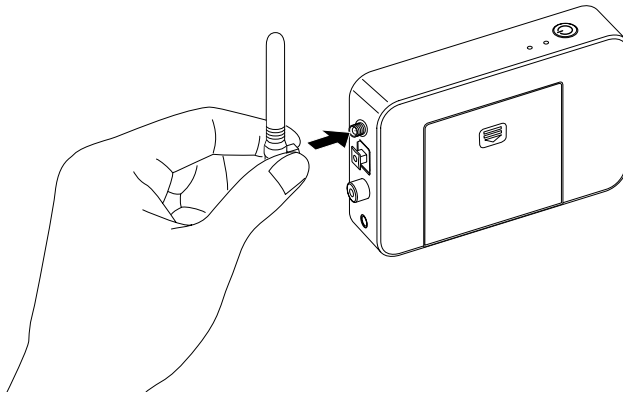

3. If necessary, rotate the antenna so that it is facing upwards.

When you’re finished attaching the antenna, see “Powering the Transmitter” on page 7.

Powering the Transmitter

The transmitter can be powered using the included power adapter or four AA batteries. To use batteries, see “Installing Batteries” below. To use the power adapter, see “Connecting the Power Adapter” on page 8.

Caution:

Use only batteries or the power adapter to power the transmitter. Using both at the same time may damage the transmitter.

Installing Batteries

1. Remove the battery cover by sliding it as shown below.

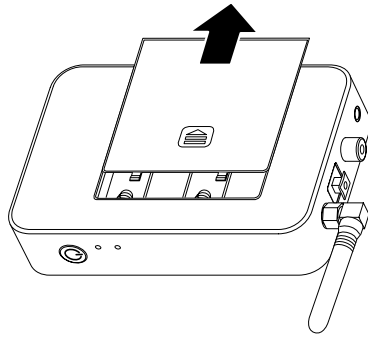

2. If necessary, remove the old batteries and insert four AA batteries as shown below.

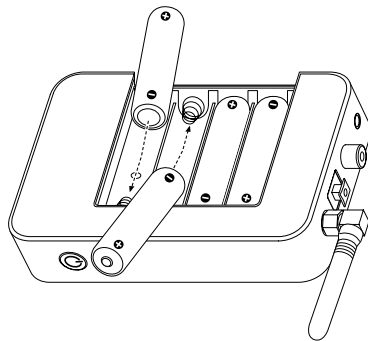

3. Replace the battery cover.

Battery Precautions

- Replace the batteries as soon as they run out. If the batteries leak, dispose of them, and wipe away the battery fluid with a soft cloth. If fluid gets on your hands, wash them immediately.
- Dispose of used batteries according to local regulations.
- Do not expose batteries to heat or flame.
- Remove the batteries if you won't be using the Wireless Audio Set for a long period of time.

When you're finished installing batteries, see "Connecting the Transmitter's Audio Cable" on page 9.

Connecting the Power Adapter

Connect the smaller power adapter to the transmitter's power port, then plug the other end into a standard electrical outlet.

Caution:

Before plugging in the power adapter, make sure to remove any batteries from the transmitter, if installed. Using both at the same time may damage the transmitter.

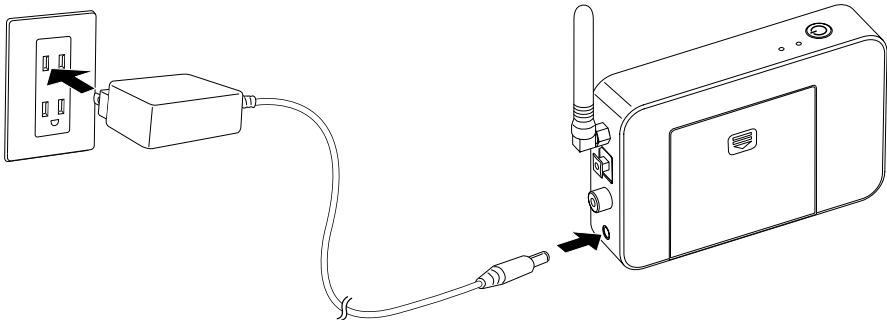

When you're finished connecting the power adapter, see "Connecting the Transmitter's Audio Cable" on page 9.

Connecting the Transmitter's Audio Cable

Follow the steps in “Connecting to an Epson MovieMate,” below, to connect the transmitter to your projector. If you're connecting the transmitter to a DVD player, see “Connecting to a DVD Player” on page 12.

Connecting to an Epson MovieMate

1. Locate the shorter optical audio cable, and remove the protective caps from both ends of the cable.
2. Remove the protective cap from the transmitter's **OPTICAL** audio input port and store it in a safe place.
3. Connect one end of the cable to the transmitter's **OPTICAL** audio input port.

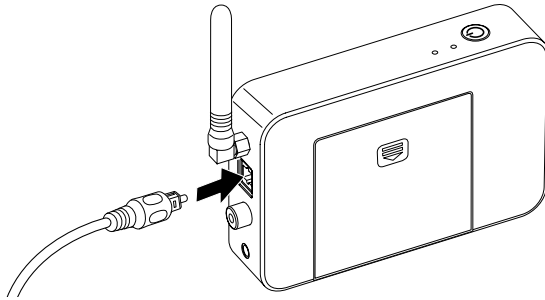

4. Place the transmitter in the included stand.

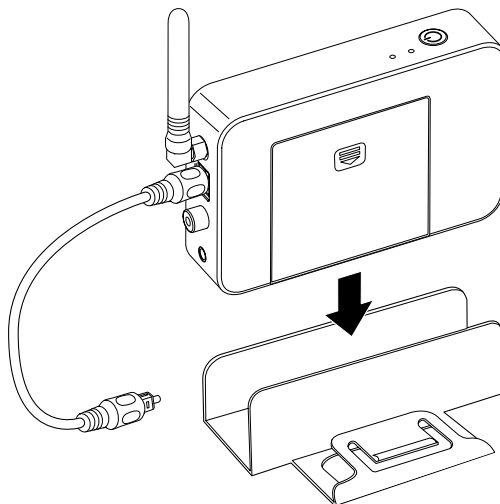

- Slide the stand under the side of the projector near the front port cover as shown below.

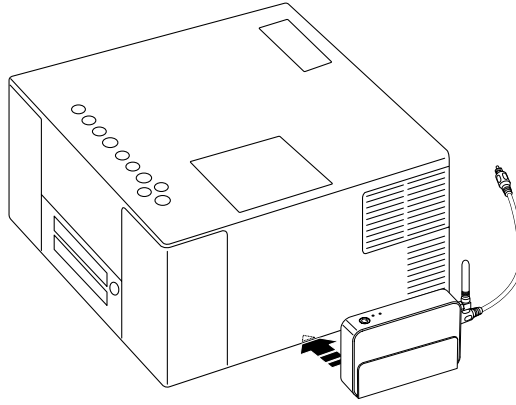

Caution:

Make sure that the transmitter is not covering the air vents on the side of the projector and that it is close enough to the front of the projector to connect the optical audio cable.

- Open the projector's front port cover.

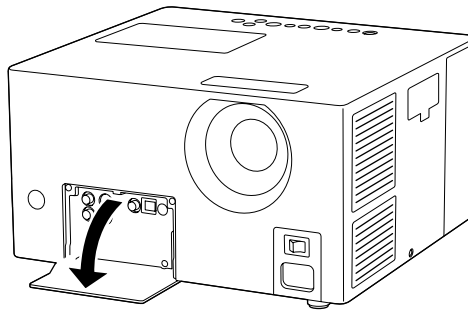

- Remove the protective cap from the projector's Optical-Audio-Out port and store it in a safe place.

8. Connect the other end of the optical audio cable to the projector's Optical-Audio-Out port.

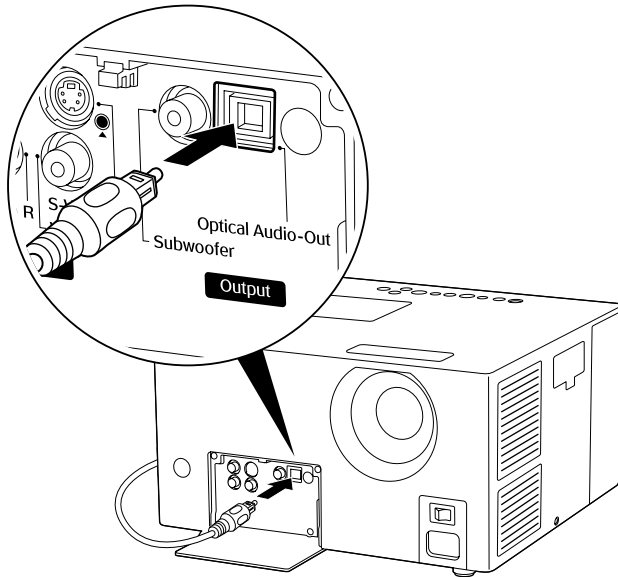

When you're finished connecting the audio cable, see "Connecting the Audio Set Receiver" on page 13.

Connecting to a DVD Player

1. Check your DVD player to determine the type of cable to use:
 - The included shorter optical audio cable
 - An optional coaxial audio cable (not provided)
2. Connect the audio cable to the transmitter, then connect the other end to your DVD player as shown below.

Note:

If you're using the optical audio cable, remove the protective caps from both ends of the cable. Then remove the protective cap from the transmitter's **OPTICAL** audio input port and store it in a safe place. You may also need to remove the protective cap from the DVD player's optical audio output port.

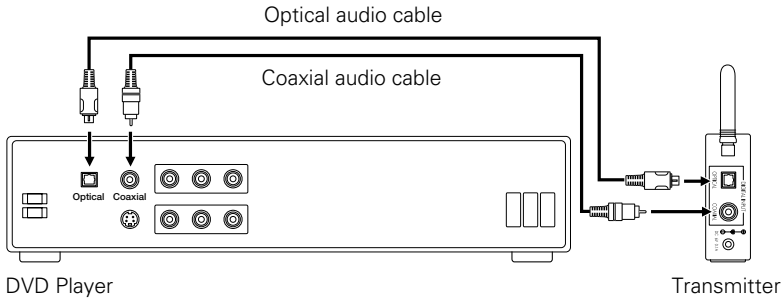

Note:

Use **only one** audio cable to connect the transmitter to your DVD player.

If you're connecting to the optical audio output on your DVD player, you may need to remove the protective cap from the DVD player's optical audio output port. See your player's documentation for more information.

Connecting the Audio Set Receiver

Before you begin, make sure that your audio system is turned off. Then follow the steps in these sections on:

- “Attaching the Antenna” below
- “Powering the Receiver” on page 14
- “Connecting the Receiver’s Audio Cable” on page 14

Attaching the Antenna

1. Remove the red cap from the receiver’s antenna connector.
2. Attach one of the included antennas to the receiver, then hand-tighten the nut at the base of the antenna.

Caution:

Do not use a tool to tighten the nut, or you may damage the receiver.

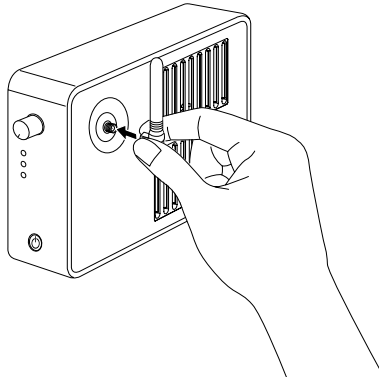

3. If necessary, rotate the antenna so that it is facing upwards.

When you’re finished attaching the antenna, see “Powering the Receiver” on page 14.

Powering the Receiver

Connect the larger power adapter to the receiver's power port, then plug the other end into an electrical outlet.

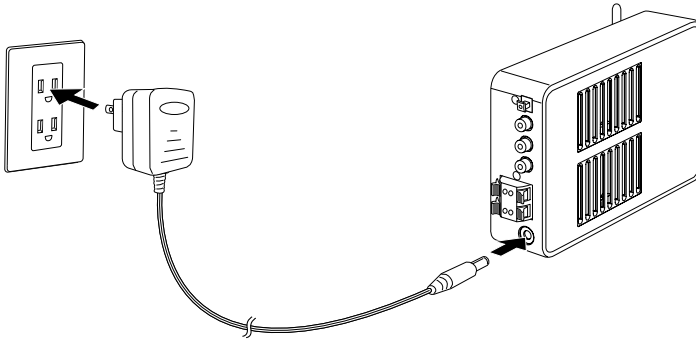

When you're done connecting the power adapter, see "Connecting the Receiver's Audio Cable" below.

Connecting the Receiver's Audio Cable

Follow the steps below to connect the receiver to an audio system. If you don't have access to an audio system, and want to connect the receiver to a pair of unpowered speakers, see page 16 for details.

Connecting to an Audio System

Before you begin, make sure that the receiver and your audio system are turned off and the audio system's volume is turned all the way down.

1. Depending on the type of audio system you have, you will need to connect the receiver to it using **only one** of the following cables:
 - The included RCA cable (stereo)
 - The included optical audio cable (surround)
 - An optional coaxial audio cable (surround)

Caution:

Make sure that the receiver and your audio system are turned off and the audio system's volume is turned all the way down before you connect the audio cable or you may damage your speakers.

2. Connect the audio cable to the receiver, then connect the other end to your audio system as shown below.

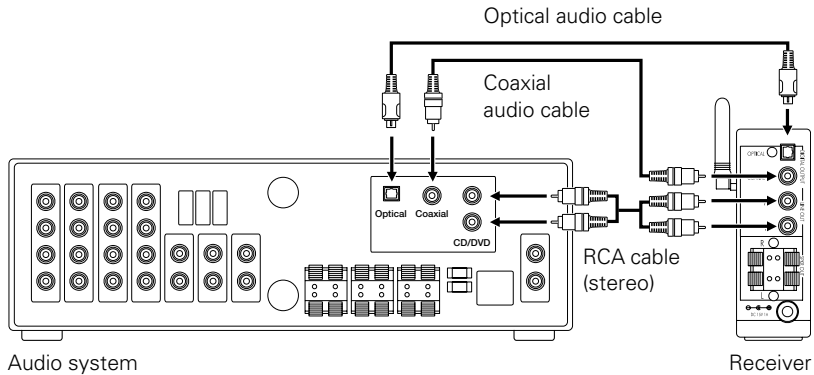

Note:

Use **only one** audio cable to connect the receiver to your audio system.

Make sure that you configure your audio system to use the input source you connected the receiver to.

When you're finished connecting the audio cable, do one of the following:

- If you connected the transmitter to an Epson MovieMate, see page 17.
- If you connected the transmitter to a DVD player, see page 18.

Connecting to Unpowered Speakers

The receiver includes a built-in 15-watt amplifier that allows you to power two 6 ohm unpowered speakers. Before you begin, make sure that the receiver is turned off and the volume control is turned all the way down.

Caution:

Do not connect more than two speakers or speakers with an impedance rating lower than 6 ohms to the receiver or you may damage the receiver and your speakers.

Warning:

Make sure that the receiver is turned off and the volume control is turned all the way down before you connect the speakers or you may damage them.



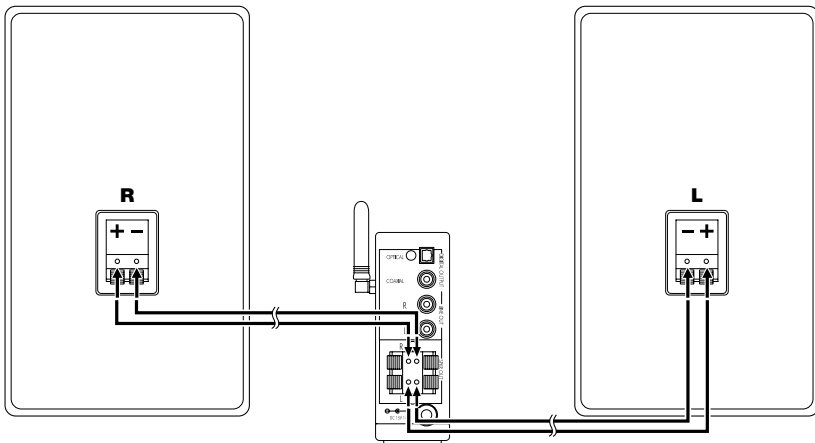





Connect your speakers to the receiver as shown below.





When you're finished connecting the speakers, do one of the following:

- If you connected the transmitter to an Epson MovieMate, see page 17.
- If you connected the transmitter to a DVD player, see page 18.

Configuring Your Epson MovieMate

1. Turn on your Epson MovieMate.
2. Press the  **Setup** button on the remote control.
3. Press the  button to highlight  and display the **AUDIO** setup menu.
4. Press the  or  button to highlight **DIGITAL AUDIO OUTPUT**, then press the  **Enter** button.
5. Press the  or  button to select the setting that matches the type of connection you used to connect the receiver to your audio system from the table below, then press the  **Enter** button.

Connection	Setting
Optical	STREAM/PCM
Coaxial	STREAM/PCM
RCA	PCM ONLY
Speaker wire	PCM ONLY

6. Press  to highlight **DOWN MIX**, then press the  **Enter** button.
7. Select the setting that matches the type of connection you used to connect the receiver to your audio system from the table below, then press the  **Enter** button.

Connection	Setting
Optical	DOLBY SURROUND
Coaxial	DOLBY SURROUND
RCA	STEREO
Speaker wire	STEREO

8. When you have finished selecting settings, press the  **Setup** button to exit the menu system.

You're finished setting up the Wireless Audio Set. See "Using the Wireless Audio Set" on page 19.

Configuring Your DVD Player

Some DVD players may require you to go into a setup or configuration menu to activate the optical or coaxial audio port and select audio setting for it. Refer to the documentation for your DVD player to select the setting that matches the type of connection you used to connect the receiver to your audio system from the table below.

Connection	Setting
Optical	SPDIF/DOLBY/DTS
Coaxial	SPDIF/DOLBY/DTS
RCA	PCM or STEREO
Speaker wire	PCM or STEREO





Note:

Your DVD player's settings may differ from the ones shown above. Refer to the documentation for your DVD player to select an equivalent setting.

You're finished setting up the Wireless Audio Set. See "Using the Wireless Audio Set" on page 19.

Using the Wireless Audio Set

Powering On Your Equipment

1. Push the  button on the transmitter. The  light turns solid green.
2. Push the  button on the receiver. The  light turns solid green.
3. Make sure that the LINK light on the transmitter and receiver is solid green.

Note:

If the LINK lights are not solid green, there is no connection between the transmitter and receiver. Make sure that there is direct line of sight between the two antennas and that the transmitter and receiver are less than 19.7 feet (6 meters) apart. If the LINK lights are still not solid green, see “Solving Problems” on page 21.

4. Turn on your Epson MovieMate or DVD player.
5. Turn on your audio system. You’re ready to start watching a movie.

Note:

If the transmitter doesn’t receive an audio signal for more than 5 minutes, it will automatically go into standby mode. If it still hasn’t received an audio signal after 25 minutes, it will turn off automatically. Press the  button to turn it back on again.

If you don’t have any audio output, make sure that the volume control on your audio system is not turned all the way down or muted; see “Controlling Volume” on page 20. If you still don’t hear any audio, see “Solving Problems” on page 21.

Controlling Volume

When connected to an audio system, the Wireless Audio Set acts just like a standard cable connection to your audio/video equipment. Use the volume control on your audio system to turn the volume up or down.

If you've connected the receiver to a pair of unpowered speakers (as described on page 16), use the volume control on the Audio Set receiver to turn the volume up or down.

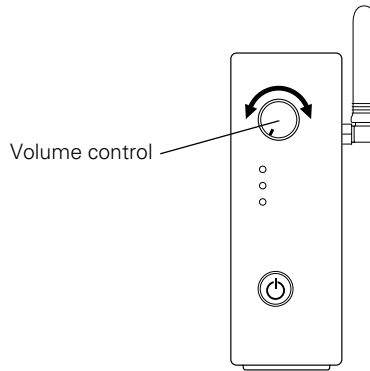





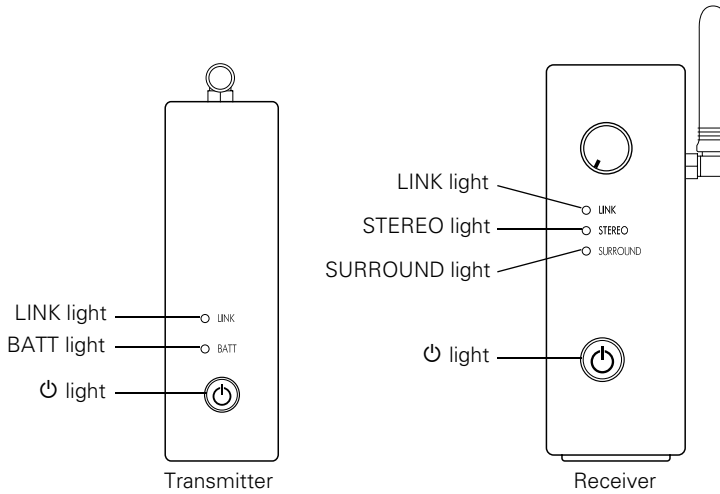







Solving Problems

Wireless Audio Set Status Lights



Refer to the table below for a description of the Wireless Audio Set's status lights and their meanings:

Lights	Explanation
The  lights are solid green	The transmitter and receiver are powered on and operating normally.
The  light is solid yellow	The transmitter has not received an audio signal from your Epson MovieMate or DVD player or hasn't had a link with the receiver and has gone into standby mode. The transmitter will turn on automatically when an audio signal is sent to it.
The  lights are off	<p>Transmitter: The transmitter is turned off. Make sure that you installed the batteries correctly or make sure that the power adapter is plugged in; see page 8. Then press the  button to turn it back on. If the transmitter has not received an audio signal after 25 minutes, it will turn off automatically.</p> <p>Receiver: The receiver is turned off. Make sure that the power adapter is plugged in; see page 14. Then press the  button to turn it back on.</p>
The  lights are solid green and the LINK lights are solid green	The transmitter and receiver are communicating normally.
The  lights are solid green and the LINK lights are flashing green	The transmitter and receiver have a weak communication signal. Make sure that there is direct line of sight between the two antennas and that the units are less than 19.7 feet (6 meters) apart.
The  lights are solid green and the LINK lights are off	There is no communication between the transmitter and receiver. Make sure that there is direct line of sight between the two antennas and that the units are less than 19.7 feet (6 meters) apart.

Lights	Explanation
<p>The transmitter's  light is solid green and the BATT light is solid red</p>	<p>The transmitter's batteries are low on power. When the light first turns on you have approximately four to five hours of battery life left. See page 7 to replace the batteries.</p> <p>The BATT light is calibrated for alkaline batteries. If you are using rechargeable batteries to power the transmitter, the BATT light may turn on prematurely.</p>
<p>The receiver's  light is solid green, the LINK light is solid green, and the STEREO light is solid green</p>	<p>The receiver is receiving a stereo signal from the transmitter.</p>
<p>The receiver's  light is solid green, the LINK light is solid green, and the SURROUND light is solid green</p>	<p>The receiver is receiving a surround signal from the transmitter.</p>
<p>The receiver's  light is solid green, the LINK light is solid green, and the SURROUND and STEREO lights are off</p>	<p>The receiver is not receiving an audio signal from the transmitter. Make sure that the audio cable is connected correctly as described on page 9.</p>

Problems and Solutions

No Sound

- Make sure that the transmitter is turned on.
- Try adjusting the volume on your home theater system. If you've connected the Wireless Audio Set to a pair of unpowered speakers, adjust the volume control on the receiver.
- Make sure that all of the audio cables are securely connected.
- Make sure that your Epson MovieMate has been configured for your audio device as described on page 17.
- Make sure that the settings on your audio system are configured correctly for the type of audio you are transmitting. See the documentation for your audio system for details.
- The transmitter's batteries may not be installed correctly or may be low on power. To change the batteries, see page 7.

Poor Sound Quality

- Make sure that the transmitter and receiver are less than 19.7 feet (6 meters) apart and that there is direct line of sight between the antennas.
- If the LINK lights are flashing, make sure that the transmitter and receiver are no further than 19.7 feet (6 meters) and that there is a direct line of sight between their antennas.
- The transmitter's batteries may be low on power. To change the batteries, see page 7.

No Surround Output

- If the SURROUND light on the receiver is not solid green, make sure that your Epson MovieMate or DVD player has been configured correctly and that the DVD you're playing supports surround audio; see page 17.
- Make sure that the settings on your audio system are configured correctly for the type of audio you are transmitting. See the documentation for your audio system for details.

Help

Internet Support

Visit our support website at epson.com/support and select your product for solutions to common problems. You can download product documentation, get FAQs and troubleshooting advice, or e-mail us with your questions.

Speak to a Support Representative

Before you call for support, please have the following information ready:

- Product name (Accolade Wireless Audio Set)
- Product serial number (located on the bottom of the units)
- Description of the problem

Then call:

- U.S.: (562) 276-4394, 6 AM to 8 PM, Pacific Time, Monday–Friday and 7 AM to 4 PM, Saturday
- Canada: (905) 709-3839, 6 AM to 6 PM, Pacific Time, Monday–Friday

Once connected, follow the voice prompts to video projector support. Toll or long distance charges may apply.

Purchase Supplies and Accessories

You can purchase projectors and accessories from an Epson® authorized reseller. To find the nearest reseller, call 800-GO-EPSON (800-463-7766). Or you can purchase online at www.epsonstore.com (U.S. sales) or www.epson.ca (Canadian sales).

Notices

Important Safety Instructions

Before using your Wireless Audio Set, read and follow these safety instructions:

- Be sure to follow all warnings and instructions marked on the Wireless Audio Set.
- Use only the types of power sources indicated on the Wireless Audio Set's labels.
- Use only the power adapters that come with the Wireless Audio Set. Use of other adapters may cause fires or shock. Do not use the adapters with any other equipment.
- Place the Wireless Audio Set near a wall outlet where the plugs can be easily unplugged.
- Do not let the power adapters' cords become damaged or frayed.
- If you use an extension cord with the Wireless Audio Set, make sure the total ampere rating of the devices plugged into the extension cord does not exceed the cord's ampere rating. Also, make sure the total ampere rating of all devices plugged into the wall outlet does not exceed the wall outlet's ampere rating.
- Avoid locations that are subject to rapid changes in heat or humidity, shocks or vibrations, or dust.
- Leave enough room around the Wireless Audio Set for sufficient ventilation. Do not block or cover openings in the Wireless Audio Set's case or insert objects through the slots.
- Do not place the Wireless Audio Set near a radiator or heating vent or in direct sunlight.
- Do not spill liquid on the Wireless Audio Set.
- Except as specifically explained in your documentation, do not attempt to service the Wireless Audio Set yourself.
- Unplug the Wireless Audio Set and refer servicing to qualified service personnel under the following conditions: if the power adapter's cord or plug is damaged; if liquid has entered the product; if the product has been dropped or the case damaged; if the product does not operate normally or exhibits a distinct change in performance. Adjust only those controls that are covered by the operating instructions.

WARNING: The cords included with this product contain chemicals, including lead, known to the State of California to cause birth defects or other reproductive harm. *Wash hands after handling.* (provided in accordance with Proposition 65 in Cal. Health & Safety Code § 25249.5 et seq)

FCC Compliance Statement

For United States Users

This equipment has been tested and found to comply with the limits pursuant to Part 15 of the FCC Rules. These limits are designed to provide reasonable protection against harmful interference in a residential installation. This equipment generates, uses, and can radiate radio frequency energy and, if not installed and used in accordance with the instructions, may cause harmful interference to radio or television reception. However, there is no guarantee that interference will not occur in a particular installation. If this equipment does cause interference to radio and television reception, which can be determined by turning the equipment off and on, the user is encouraged to try to correct the interference by one or more of the following measures:

- Reorient or relocate the receiving antenna.
- Increase the separation between the equipment and receiver.
- Connect the equipment into an outlet on a circuit different from that to which the receiver is connected.
- Consult the dealer or an experienced radio/TV technician for help.

WARNING

The connection of a non-shielded equipment interface cable to this equipment will invalidate the FCC Certification of this device and may cause interference levels which exceed the limits established by the FCC for this equipment. It is the responsibility of the user to obtain and use a shielded equipment interface cable with this device. If this equipment has more than one interface connector, do not leave cables connected to unused interfaces. Changes or modifications not expressly approved by the manufacturer could void the user's authority to operate the equipment.

Declaration of Conformity

We: Epson America, Inc.
Located at: MS 3-13
3840 Kilroy Airport Way
Long Beach, CA 90806
Telephone: (562) 290-5254

Declare under sole responsibility that the product identified herein, complies with Part 15 of the FCC rules. Operation is subject to the following two conditions: (1) this device may not cause harmful interference, and (2) this device must accept any interference received, including interference that may cause undesired operation.

Trade Name: Epson
Type of Product: Wireless Audio Transmitter/Receiver
Model: ELPWA01T/ELPWA02R

Warranty

Limited Warranty for Wireless Audio Set Accessory Product

What Is Covered: Epson America, Inc. (“Epson”) warrants to the first retail purchaser that the product enclosed with this limited warranty statement, if purchased new and operated in the United States or Canada, will be free from defects in workmanship and materials for a period of one (1) year from the date of original purchase. For warranty service, you must provide proof of the date of original purchase.

What Epson Will Do To Correct Problems: Should this product prove defective during the warranty period, please call the Epson ConnectionSM at (562) 276-4394 in the U.S. and (905) 709-3839 in Canada for warranty instructions and return authorization. An Epson service technician will provide telephone diagnostic service to determine whether the product requires service. If service is needed, Epson will, at its option, exchange or repair the product without charge for parts or labor. When Epson authorizes an exchange for the defective unit, Epson will ship a replacement product to you, freight prepaid, so long as you use an address in Canada or the U.S. (excluding Puerto Rico and U.S. Possessions). Shipments to other locations will be made freight collect. You are responsible for securely packaging the defective unit and returning it to Epson within five (5) working days of receipt of the replacement. Epson requires a debit or a credit card number to secure the cost of the replacement product in the event that you fail to return the defective one. When warranty service involves the exchange of the product or of a part, the item replaced becomes Epson property. The replacement product or part may be new or refurbished to the Epson standard of quality, and, at Epson’s option, may be another model of like kind and quality. Epson’s liability for replacement of the covered product will not exceed the original retail selling price of the covered product. Exchange products and parts assume the remaining warranty period of your original product covered by this limited warranty.

What This Warranty Does Not Cover: This warranty does not apply to refurbished or reconditioned products. This warranty covers only normal use in the United States and Canada. This warranty is not transferable and will not apply to products purchased from an end user. This warranty does not cover damage to the Epson product caused by parts or supplies not manufactured, distributed or certified by Epson. This warranty does not cover third party parts, components or peripheral devices added to the Epson product after its shipment from Epson. Epson is not responsible for warranty service should any labels, logos or serial numbers be removed or should the product fail to be properly maintained or fail to function properly as a result of misuse, abuse, improper installation, neglect, improper shipping, damage caused by disasters such as fire, flood, and lightning, improper electrical current, interaction with non-Epson products, or service other than by an Epson Authorized Servicer. If a claimed defect cannot be identified or reproduced, you will be held responsible for costs incurred.

THE WARRANTY AND REMEDY PROVIDED ABOVE ARE EXCLUSIVE AND IN LIEU OF ALL OTHER EXPRESS OR IMPLIED WARRANTIES INCLUDING, BUT NOT LIMITED TO, THE IMPLIED WARRANTIES OF MERCHANTABILITY, NON-INFRINGEMENT OR FITNESS FOR A PARTICULAR PURPOSE. SOME LAWS DO NOT ALLOW THE EXCLUSION OF IMPLIED WARRANTIES. IF THESE LAWS APPLY, THEN ALL EXPRESS AND IMPLIED WARRANTIES ARE LIMITED TO THE WARRANTY PERIOD IDENTIFIED ABOVE. UNLESS STATED HEREIN, ANY STATEMENT OR REPRESENTATIONS MADE BY ANY OTHER PERSON OR FIRM ARE VOID. EXCEPT AS PROVIDED IN THIS WRITTEN WARRANTY, NEITHER EPSON AMERICA, INC., NOR ITS AFFILIATES SHALL BE LIABLE FOR ANY LOSS, INCONVENIENCE, OR DAMAGE, INCLUDING DIRECT, SPECIAL, INCIDENTAL OR CONSEQUENTIAL DAMAGES, RESULTING FROM THE USE OR INABILITY TO USE THE EPSON PRODUCT, OR FOR LOST DATA OR LOST SOFTWARE WHETHER RESULTING FROM BREACH OF WARRANTY OR ANY OTHER LEGAL THEORY.

In Canada, warranties include both warranties and conditions. Some jurisdictions do not allow limitations on how long an implied warranty lasts and some jurisdictions do not allow the exclusion or limitation of incidental or consequential damages, so the above limitations and exclusions may not apply to you. This warranty gives you specific legal rights, and you may also have other rights which vary from jurisdiction to jurisdiction.

To find the Epson Authorized Reseller nearest you, visit our website at www.epsonstore.com (U.S. sales) or www.epson.ca (Canadian sales).

To find the Epson Customer Care Center nearest you, visit <http://support.epson.com> or write to:

Epson America, Inc., P. O. Box 93012, Long Beach, CA 90809-3012

Trademarks

Epson is a registered trademark of Seiko Epson Corporation.

Accolade and Epson MovieMate are trademarks and Epson Connection is a service mark of Epson America, Inc.

General Notice: Other product names used herein are for identification purposes only and may be trademarks of their respective owners. Epson disclaims any and all rights in those marks.

Accolade™