

# **EPSON<sup>®</sup> 1000 ICS**

## **Basics**

# EPSON Ink Jet Papers and Ink Cartridges

Use EPSON paper and inks to get the same photo quality results that have earned EPSON's printers all of their awards! EPSON papers are specially coated to work with EPSON's quick drying inks. You'll notice that when prints come out of your printer, you can immediately handle them. There is no drying time, no smearing or smudging, and your image is crisp and smooth. Here are the inks for your printer and just a few of EPSON's papers:

## ***Glossy Photo Paper and Panoramic Photo Paper***

Photo lab quality, heavier weight glossy paper available in a variety of sizes. Perfect for color photo keepsakes of snapshots, framed art, banners, and panoramics.

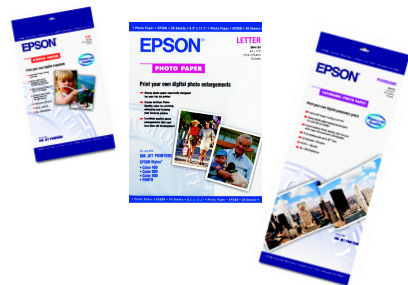

## ***Matte Paper - Heavyweight***



Heavyweight, bright white, ultra smooth coated paper with matte finish. Perfect for photographs, signs, and crafts.

## ***Photo Quality Ink Jet Paper***

Bright white, with a smooth matte finish to create your best impression. Perfect for presentations, newsletters, color reproductions, and all your photo and craft projects.



## ***EPSON Ink Cartridges***

For best results, always use genuine EPSON ink cartridges.

Black                    T017  
Color                    T018



For more information on other EPSON products and fun project ideas, look for the EPSON Print Lab<sup>SM</sup> Series at [www.epson.com](http://www.epson.com).

*See the inside back cover for a list of EPSON papers and ink cartridges, and ordering information.*

## Copyright Notice

All rights reserved. No part of this publication may be reproduced, stored in a retrieval system, or transmitted in any form or by any means, electronic, mechanical, photocopying, recording, or otherwise, without the prior written permission of SEIKO EPSON CORPORATION. The information contained herein is designed only for use with this EPSON product. EPSON is not responsible for any use of this information as applied to other equipment.

Neither SEIKO EPSON CORPORATION nor its affiliates shall be liable to the purchaser of this product or third parties for damages, losses, costs, or expenses incurred by purchaser or third parties as a result of: accident, misuse, or abuse of this product or unauthorized modifications, repairs, or alterations to this product, or (excluding the U.S.) failure to strictly comply with SEIKO EPSON CORPORATION's operating and maintenance instructions.

SEIKO EPSON CORPORATION shall not be liable for any damages or problems arising from the use of any options or any consumable products other than those designated as Original EPSON Products or EPSON Approved Products by SEIKO EPSON CORPORATION.

## A Note Concerning Responsible Use of Copyrighted Materials

Digital cameras, scanners, and ink jet printers, like conventional photocopiers and cameras, can be misused by improper copying or printing of copyrighted material. While some countries' laws permit limited copying of copyrighted material in certain circumstances, those circumstances may not be as broad as some people assume. EPSON encourages each user to be responsible and respectful of the copyright laws when using digital cameras, scanners, and ink jet printers.

## Trademarks

EPSON and EPSON Photo Stickers are registered trademarks and EPSON Smart Panel is a trademark of SEIKO EPSON CORPORATION.

PhotoEnhance is a trademark and EPSON Connection, EPSON PhotoCenter, EPSON Store, Print Lab, and SoundAdvice are service marks of Epson America, Inc.

General Notice: Other product names used herein are for identification purposes only and may be trademarks of their respective owners. EPSON disclaims any and all rights in those marks.

The ENERGY STAR emblem does not represent EPA endorsement of any product or service.



Printed on recycled paper

CPD-13965

3/02

# Contents

<b>Welcome!</b>	<b>1</b>
About Your Software	1
About Your Documentation	1
Warnings, Cautions, Notes, and Tips	1
Viewing Your Electronic Reference Guide	2
<b>Copying</b>	<b>3</b>
Stand-alone Copying	3
Changing Copy Settings	4
Making Copies With the Computer	5
<b>Printing</b>	<b>7</b>
Loading Paper	7
Opening the Printer Software	8
Selecting Printer Software Settings	9
Selecting Default Print Settings for All Applications	10
Controlling Printing	10
Using PhotoEnhance, Custom, and Advanced Settings	11
Enhancing Photos	12
Using Custom Project Types	12
Using Advanced Settings	13
Using Special Papers	14
EPSON Matte Paper - Heavyweight	14
EPSON Glossy Photo Paper	14
Printing on Envelopes	15
Selecting the Correct Media Type	16
<b>Scanning</b>	<b>17</b>
Placing Your Original Document	17
Scanning to a File in EPSON Smart Panel	18
One-Touch Scanning	20
Advanced Scanning With EPSON TWAIN	22

<b>Maintenance</b>	<b>25</b>
Cleaning the Print Head	25
Aligning the Print Head	26
Replacing an Ink Cartridge	27
Checking the Ink Supply	28
Purchasing Ink Cartridges	28
Ink Cartridge Precautions	29
Removing and Installing Ink Cartridges	29
Cleaning the EPSON 1000 ICS	31
Transporting the EPSON 1000 ICS	33
<b>Problem Solving</b>	<b>35</b>
Identifying Parts	35
Diagnosing Problems	37
Checking the Control Panel Error Messages	37
Printing a Nozzle Check	39
Problems and Solutions	39
Setup and Software Installation Problems	39
Printing and Copying Problems	40
Scanning Problems	42
Problems with Paper Feeding	43
Print Quality Problems	44
Scan Quality Problems	46
Uninstalling and Reinstalling Your Software	48
Where To Get Help	49
EPSON Technical Support	49
Software Technical Support	50
<b>Requirements and Notices</b>	<b>51</b>
Windows System Requirements	51
ENERGY STAR Compliance	52
Important Safety Instructions	52
Ink Cartridge Safety Instructions	53
FCC Compliance Statement	54
Declaration of Conformity	55
Epson America, Inc. Limited Warranty	55
<b>Index</b>	<b>57</b>

# Welcome!

Your EPSON® 1000 ICS is an ideal device for copying, scanning, and printing.

---

## About Your Software



### *EPSON TWAIN*

Scanner driver with powerful features for controlling every aspect of your scan.



### *EPSON Smart Panel,™ by NewSoft™*

An easy, step-by-step interface for scanning, copying, printing, and more.



### *ArcSoft™ PhotoImpression™*

Software for editing, retouching, or enhancing images and printing images with templates, frames, and borders.

---

## About Your Documentation

To set up your EPSON 1000 ICS and install its software, see the *Start Here* poster. This book contains instructions on copying, printing, scanning, maintenance and troubleshooting. For additional information, see your electronic *Reference Guide*, as described on page 2.

## **Warnings, Cautions, Notes, and Tips**



Warnings must be followed carefully to avoid bodily injury.



Cautions must be observed to avoid damage to your equipment.



Notes contain important information about your EPSON 1000 ICS.



Tips contain additional hints for better scanning and printing.

# Viewing Your Electronic Reference Guide

Your software CD-ROM includes an electronic *Reference Guide* for your product that you installed when you installed your software (see the *Start Here* poster for details). The manual is in HTML format, so you need a browser—such as Microsoft® Internet Explorer 3.0 or later, or Netscape Navigator® 3.0 or later—to view it. If you are using a different browser, the pages may not display correctly.



A browser is not included on the EPSON 1000 ICS CD-ROM.

You can view your electronic *Reference Guide* from your hard drive: click Start > All Programs or Programs > EPSON > Online Reference Guide > Online Reference Guide.

When you open the *Reference Guide*, you see this screen:

closed list, click to expand

click to go to topic

EPSON 1000 ICS  
Online Reference Guide

Index Home Search Help Glossary

## Welcome to the EPSON Online Reference Guide

This software Online Reference Guide is your on-screen guide to your EPSON 1000 ICS printer. By clicking the links on the left side of this screen, you can get information on the following topics.

**Printing**  
How to print

**Scanning**  
How to scan

**Copying**  
How to copy

- Printing
- Scanning
  - Scanning an Image
    - Overview
    - Placing a Document
    - Scanning from the Full Auto Mode
    - Using the Scan Button on the Control Panel
    - Saving a Scanned Image
    - Customizing the Full Auto Mode Settings
    - Assigning Another Application to the Button
  - Scanning from the Manual Mode
    - Using the Preview Window
    - Optimizing Images on the Manual Mode
    - Customizing the Manual Mode Settings
    - EPSON Smart Panel
- Copying
- How to
- Problem Solver

Click a topic on the left to expand the table of contents.

After expanding the table of contents, you can click on the topic you want to view.

If there's a right arrow , click it to view subtopics, then click on a topic to go to it.

Click the down arrow  to close a subtopic list.



If you see an icon in place of a graphic when viewing your *Reference Guide* in Netscape Navigator, click the Reload button to load the graphic.

# Copying

Your EPSON 1000 ICS lets you make copies without ever turning on your computer. You can also make copies by using the Copy utility in EPSON Smart Panel.

---

## Stand-alone Copying

1. Make sure the EPSON 1000 ICS is on and paper is loaded in the sheet feeder.

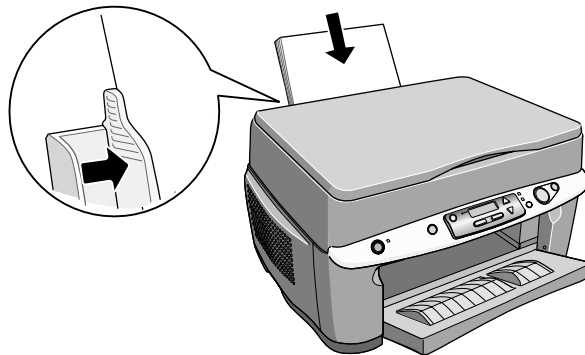

2. Place your document face-down on the glass and close the cover.

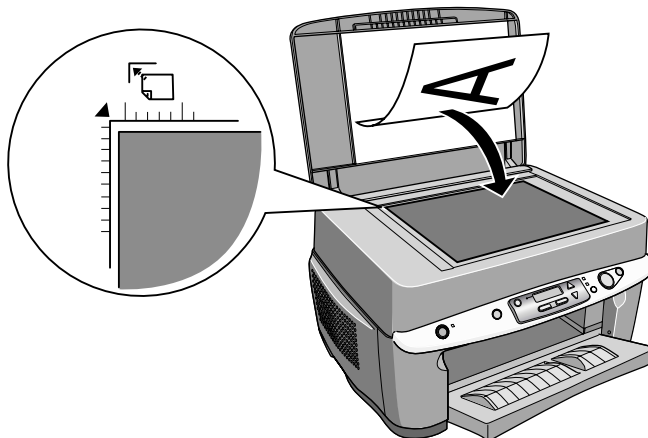

3. Press the green  Copy button. Your document is scanned and printed.



# Changing Copy Settings

You can change Copy settings on the Control Panel as described below.

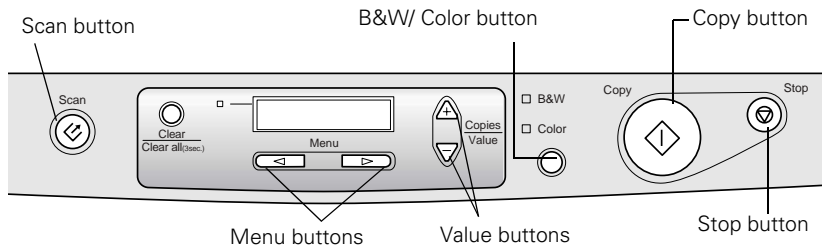

- Change the number of copies by pressing the Value buttons.
- Choose color or black and white copies by pressing the B&W/Color button.
- To change the print quality: press one of the Menu buttons to select the print quality menu, then use the Value buttons to select Normal, Fine, Photo, or Economy.
- To change the paper size: press one of the Menu buttons to select the paper size menu, then press the Value buttons to select Letter, Executive, Half Letter, or 4 × 6.
- To reduce or enlarge your image to fit on a smaller or larger size of paper, press one of the Menu buttons to select Reduce/Enlarge, then press the Value buttons to choose the paper sizes for your source image and copy.
- To manually reduce or enlarge your image, press one of the Menu buttons to select Zoom In/Out, then press the Value buttons to choose a percentage of the scanned image for the resulting print.
- To lighten or darken your copies, press one of the Menu buttons until you see Lighter/Darker. Press the Value buttons to adjust the setting.
- To reduce the bottom margin, press one of the Menu buttons until you see Bottom Margin, then press the - Value button.
- Go back to the main menu by pressing the ⏹ Stop button.
- Check your settings, then press the ⬠ Copy button to make your copy.



To clear a setting, press the Clear button. To clear all the setting changes you've made, press the Clear button and hold it down for at least 3 seconds.

# Making Copies With the Computer

1. Make sure the EPSON 1000 ICS is on and that paper is loaded in the sheet feeder.
2. Place your document face-down on the glass and close the cover.
3. Open EPSON Smart Panel: click Start > All Programs or Programs > EPSON Smart Panel > EPSON Smart Panel.
4. Click the button for the Copy Utility.



You see the Copy Settings screen.

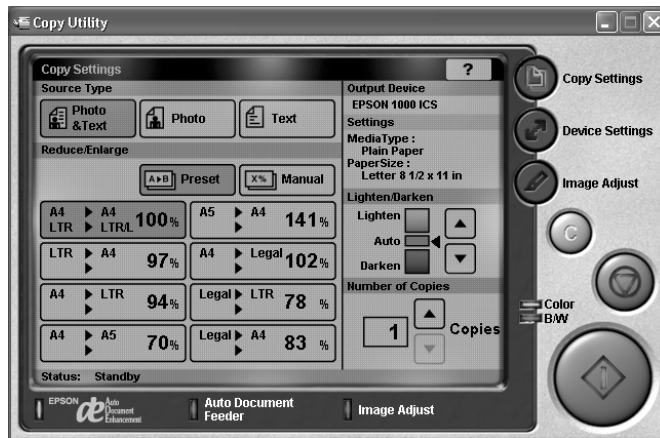

5. Adjust any of the following copy settings:
  - Source type: choose Photo & Text, Photo, or Text
  - Size: Choose the setting based on your original and your copy, or click Manual and enter a percentage to reduce or enlarge your copy by a specific amount.
  - Lighten or darken the image by clicking the up and down arrows
  - Type in a new number of copies or click the up and down arrows

6. Click the Device Settings button.



You should see your EPSON 1000 ICS chosen as the output device and EPSON TWAIN FB (your scanning software for the EPSON 1000 ICS) chosen as the input device. Click the Settings button for additional print options including settings for different types of paper. (See “Selecting Printer Software Settings” on page 9 for details.)

7. Click the Image Adjust button to enhance your image or add effects:

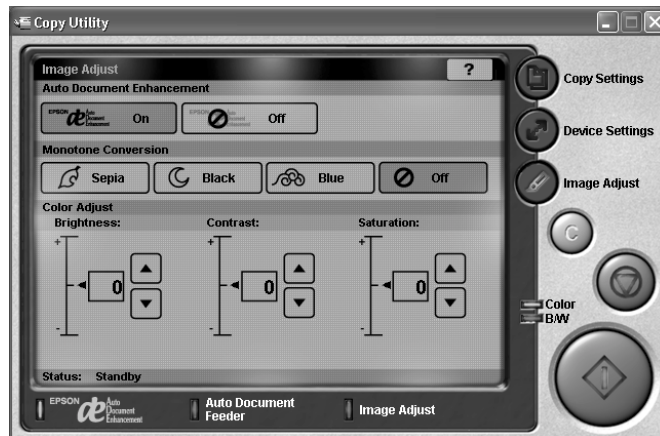

- Enable or disable the automatic document enhancement feature
- Add a sepia, blue, or black and white filter
- Adjust brightness, contrast, or saturation levels

8. Click the Copy button to start copying.



## 6 Making Copies With the Computer

# Printing

This section describes the basic steps for printing with your EPSON 1000 ICS.

---

## Loading Paper

Make sure your EPSON 1000 ICS and computer are turned on.

Place your paper against the right edge of the sheet feeder and slide the left edge guide against the paper. (Don't push the paper deeper into the feeder.)

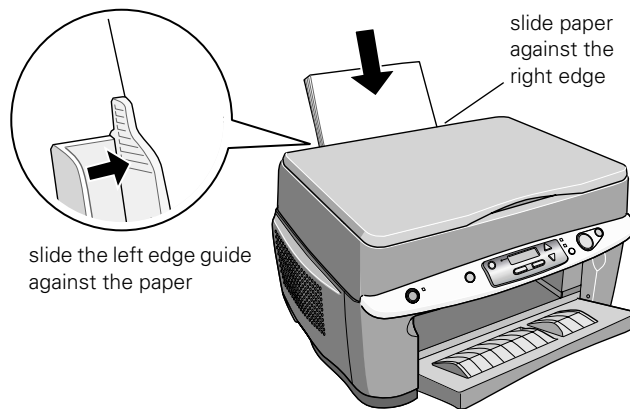

Follow these guidelines when loading paper:

- Load the printable side face-up. It's usually whiter or brighter than the other side.
- Load letterhead or preprinted paper into the EPSON 1000 ICS top edge first.
- Don't load paper above the mark on the left edge guide.



If you're printing on envelopes, see page 15 for loading instructions.

# Opening the Printer Software

After you open your application program and create your document, you're ready to select your printer software settings.

From the File menu, click Print. You see your application's Print dialog box (your dialog box may look slightly different):

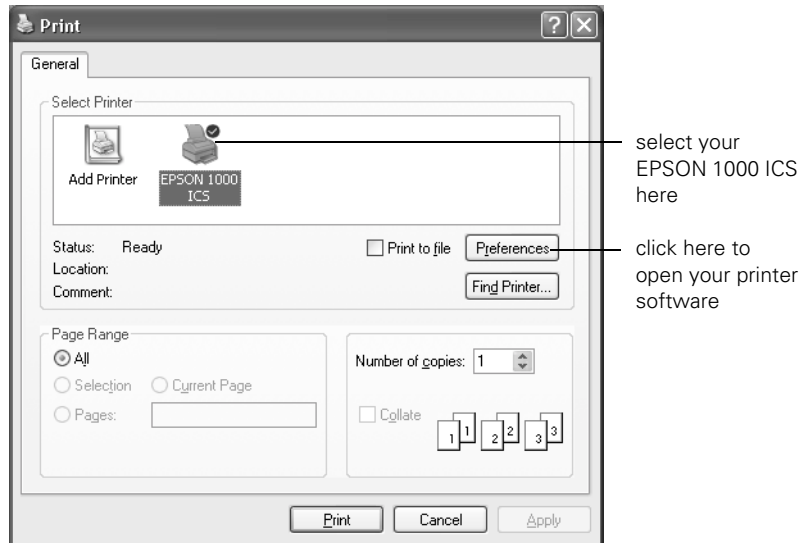

Make the following selections on the Print dialog box:

- Make sure EPSON 1000 ICS is selected.
- Click the Preferences or Properties button. (If you see a Setup, Printer, or Options button, click it. Then click Preferences or Properties on the next screen.)



If you click the print icon on your application's tool bar instead of selecting Print from the File menu, you may not get the option to change the printer software settings before printing.

# Selecting Printer Software Settings

Once you click Properties, you see your printer software dialog box.

The most important thing to remember is to set the correct Media Type for the paper you're using. If necessary, click the Main tab to display the settings shown below:

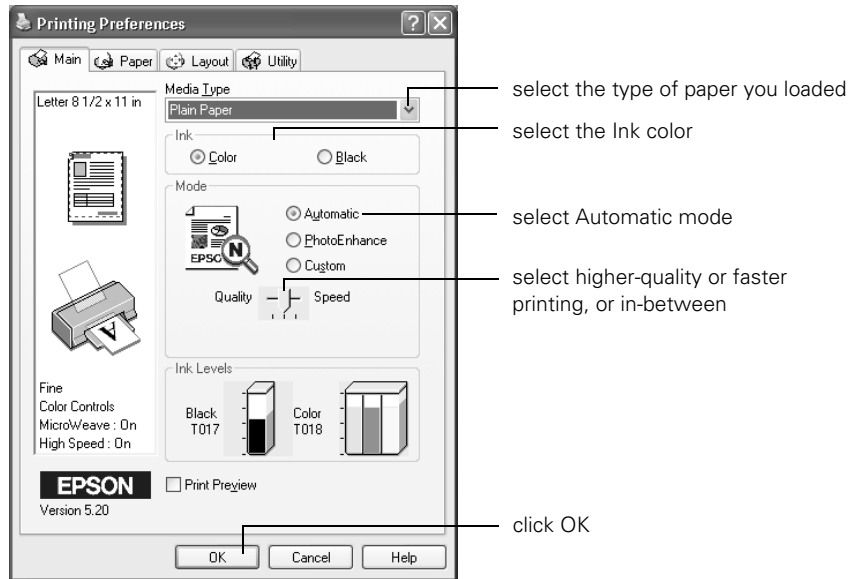

Make the following settings on the Printing Preferences or Properties dialog box:

- Choose the paper you're printing on (click the arrow to scroll through the Media Type list). If you're not sure which setting to select, see page 16.
- Set the Ink option to Color to print a color document. To print a black text document, click Black.
- Set the Mode option to Automatic. It's the easiest way to get good printing results on all types of paper.
- Set the slider in the Mode box to Quality or Speed to select high-quality printing, faster printing, or an in-between setting. (The slider may not be available for your paper type.)
- Click OK to return to your application's Print dialog box.

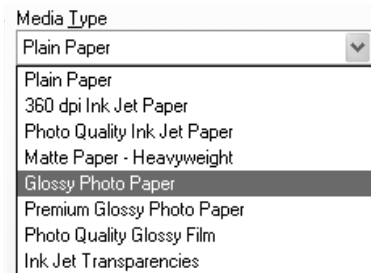

## Selecting Default Print Settings for All Applications

The printer settings you make apply only to the application you're currently using. If you usually print one type of document in different applications—for example, legal-sized documents with black ink—you can change the default printer settings for all your programs. You do this using the Windows Printers utility.

1. In Windows XP, click Start > Control Panel > Printers and Other Hardware > Printers and Faxes.

In Windows 2000, Windows Me, or Windows 98, click Start > Settings > Printers.

2. Right-click the EPSON 1000 ICS icon.
3. Select Printing Preferences (Windows XP or Windows 2000) or Properties (Windows Me or Windows 98). Then click the Main tab.
4. Select the default settings you want to use for all your applications. Click OK when you're finished.

Remember that you can always change the settings in your application when you want to print different types of documents.

---

## Controlling Printing

At the Print dialog box, click Print (or OK) to start printing.

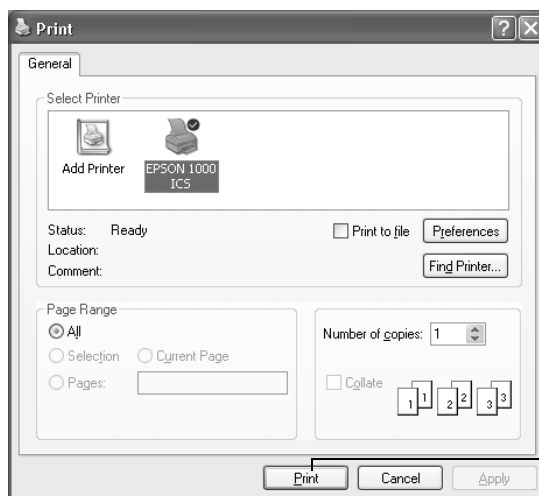

After a moment, the Progress Meter appears and shows the progress of your print job and how much ink you have left. Use the buttons to cancel, pause, or restart printing.

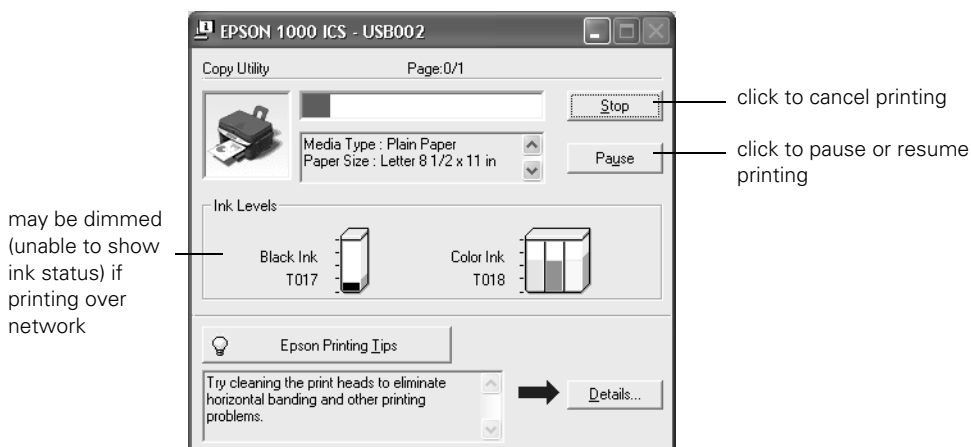

For more advanced printer settings, see the next section. For more information on printing—for example, previewing your printout, changing the paper size, or adding a watermark—see your electronic *Reference Guide* (described on page 2).

---

## Using PhotoEnhance, Custom, and Advanced Settings

When you're printing special projects, you can customize your printer software settings, as described in these sections below.

For additional information on these settings, see the electronic *Reference Guide*, as described on page 2.



## Enhancing Photos

The printer software includes PhotoEnhance™ options that adjust image brightness and contrast to improve the appearance of low-resolution and improperly exposed photos. You can also use PhotoEnhance to add special effects.



If you're printing high-resolution images, you may want to use the Automatic setting instead, as described on page 9.

PhotoEnhance does not affect your original image; it only affects your printout. Printing with PhotoEnhance may take longer on some systems.

To use PhotoEnhance, you must select Color ink; you cannot turn on PhotoEnhance with Black ink selected.

To use PhotoEnhance, set the Mode option to PhotoEnhance in your printer settings dialog box.

If your photograph was taken with a digital camera, you can select Digital Camera Correction to give your printed images the appearance of photographs taken with a film camera.

For more fine-tuning, you can select from a list of specialized settings for photographs, such as People or Nature, or select special filters, such as Soft Focus or a Sepia tint.

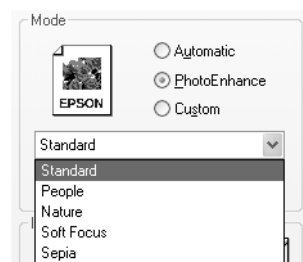

## Using Custom Project Types

Your printer software includes custom project types with preset printing options. This lets you quickly select the best settings for your type of document, or select a color-matching method for your project.

To access the project types, click Custom, then click the Custom Settings list to open it. Then select one of these settings:

- Text/Graph: For printing graphics-intensive documents like presentations with charts and graphs.
- Economy: For printing rough drafts of text on plain paper. Saves ink.

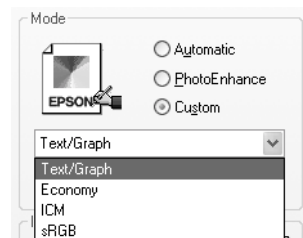

- ICM (Image Color Matching): For printing documents created in an ICM compatible application.
- sRGB (standard Red Green Blue): For printing documents created in an sRGB compatible application using sRGB colors, such as those designed for the World Wide Web. See your Windows online help for details.



You can also fine-tune these settings on the Advanced dialog box to fit your individual needs, as described below.

## Using Advanced Settings

For maximum control over your project, you can customize your print settings—such as Print Quality and Gamma—and use special effects.

To access these settings in your printer software, click Custom and then click the Advanced button. You see the Advanced dialog box.

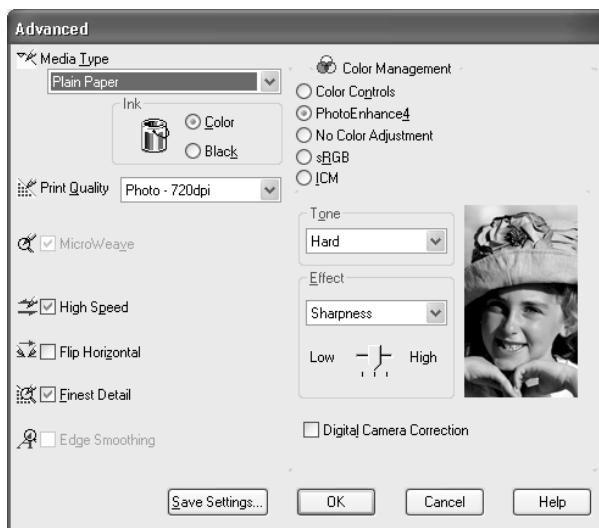

After you customize your print settings on the Advanced dialog box, you can save them as a group so you can reuse them whenever you print a similar project. For details on all the settings, click Help on-screen or see your electronic *Reference Guide* (as described on page 2).



The default Gamma setting of 1.8 provides the optimum contrast quality for your photos. However, you can change it to either 1.5 (for decreased contrast) or 2.2 (for increased contrast; recommended for matching colors with sRGB devices).

---

# Using Special Papers

How can you get the best-looking photos, most vivid colors, and sharpest text? Always use EPSON's special ink jet papers. Instructions for printing on a couple of our most popular papers are given below.



For instructions on using other EPSON special papers, see the electronic *Reference Guide*, as described on page 2. For a list of EPSON special ink jet papers and ordering information, see the inside back cover.

## ***EPSON Matte Paper - Heavyweight***

EPSON Matte Paper - Heavyweight has a professional-looking, flat matte finish for printing photos and graphics on a non-glossy surface. Load up to 20 sheets as described on page 7, including a support sheet beneath the stack. Before printing, select Matte Paper - Heavyweight as the Media Type setting.

## ***EPSON Glossy Photo Paper***

EPSON Glossy Photo Paper lets you print photographs that look almost as good as the ones you get from film processing. When using EPSON Glossy Photo Paper:

- Always load the paper with the whiter (glossier) side facing up.
- Load up to 20 sheets of 4 × 6-inch, letter-size, or A4-size Glossy Photo Paper, or 1 sheet of Panoramic paper. Use a support sheet if it is included in the package.
- Select Glossy Photo Paper as the Media Type setting.
- Store prints in a resealable plastic bag or other airtight covering and protect them from heat, humidity, and direct sunlight. Return unused paper to the original package as soon as you finish printing.

---

# Printing on Envelopes

You can load up to 10 envelopes at a time, flap edge first and printable side up. Place them against the right edge of the sheet feeder and slide the left edge guide against them.

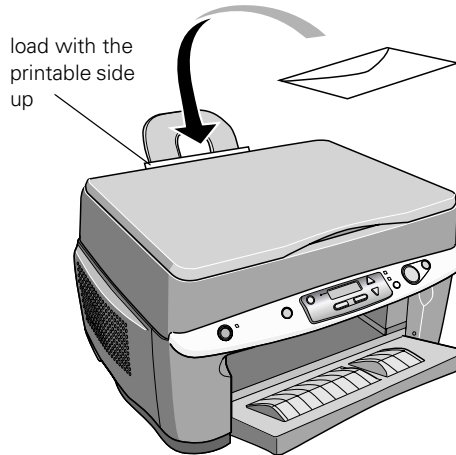

(For best results, press each envelope flat before loading, or load one envelope at a time.)

Select Plain paper as the Media Type setting and choose the correct envelope size as the Paper Size setting.

If your printout has smears or banding (light lines), try turning off High Speed in the Advanced dialog box. (See the instructions on page 13 to access the dialog box.)

# Selecting the Correct Media Type

Your printer automatically adjusts itself for the type of paper you select in your printer software. That's why the Media Type setting is so important. It tells your printer what kind of paper you're using and adjusts the ink coverage accordingly.

Here are the settings you should choose for your paper:

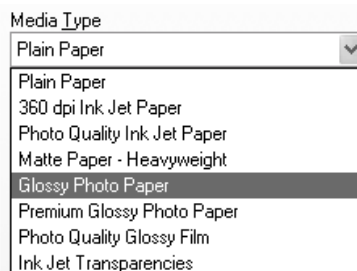

For this paper . . .	Select this Media Type setting . . .
Plain paper sheets or envelopes	Plain paper
EPSON Iron-On Cool Peel Transfer Paper	360 dpi Ink Jet Paper
EPSON High Quality Ink Jet Paper EPSON Photo Quality Ink Jet Paper EPSON Photo Quality Ink Jet Cards EPSON Photo Quality Self Adhesive Sheets	Photo Quality Ink Jet Paper
EPSON Glossy Photo Paper (Photo Paper) EPSON Photo Quality Glossy Paper EPSON Glossy Photo Greeting Cards	Glossy Photo Paper
EPSON Premium Glossy Photo Paper	Premium Glossy Photo Paper
EPSON Photo Quality Glossy Film EPSON Photo Stickers®	Photo Quality Glossy Film
EPSON Ink Jet Transparencies	Ink Jet Transparencies
EPSON Matte Paper - Heavyweight	Matte Paper - Heavyweight



If any paper you buy comes with a cleaning sheet, don't use the cleaning sheet with the EPSON 1000 ICS; it may jam inside the product.



The availability of paper types varies by location.

# Scanning

With your EPSON 1000 ICS you can scan files directly to your computer and various applications using EPSON Smart Panel, scan with advanced settings in EPSON TWAIN, and set up the  Scan button for one-touch scanning.

## Placing Your Original Document

1. Raise the document cover and place your document face-down on the document table glass.
2. Position the document so the horizontal and vertical edges are aligned with the guides on the top and left side of the document table. Be sure to leave a small gap because an area of 0.2 inch (5 mm) out from the guides is not scanned.

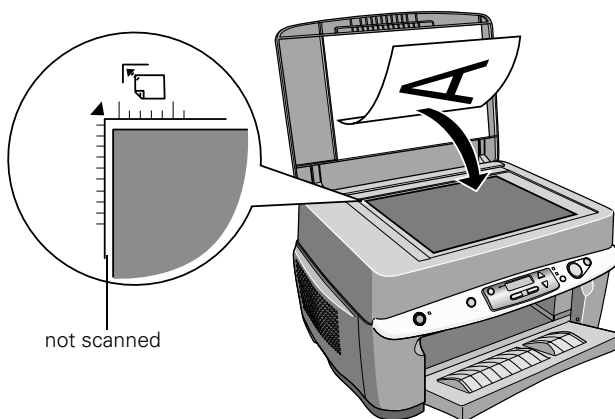

3. Close the document cover slowly. Be careful not to move the document.



If you place your document against the guides, the document edges next to the guides won't be scanned.

# Scanning to a File in EPSON Smart Panel

Smart Panel is a simple way to scan directly to a file in just a few steps.

1. Place the document face-down on the glass, in the top, left corner.
2. Click Start > All Programs or Programs > EPSON Smart Panel.

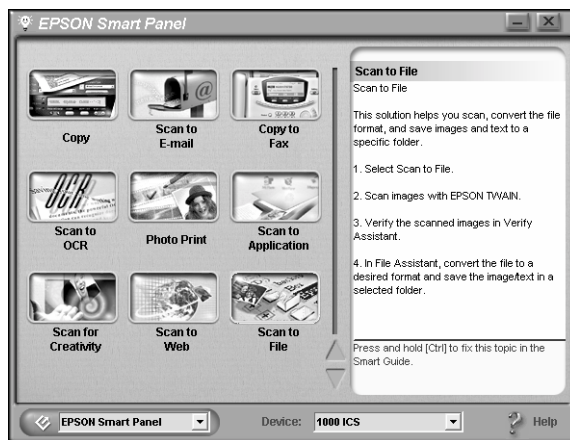

3. Click the Scan to File button.

Smart Panel starts EPSON TWAIN, which automatically scans your document.

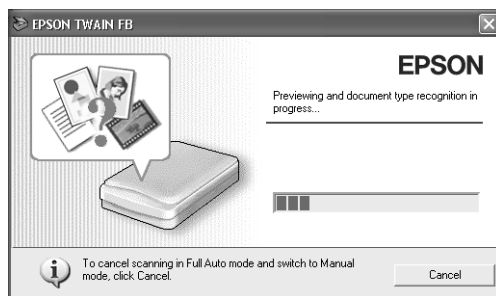

4. In the following screen, double-click a photo to make sure it scanned properly. To rename the image, click the file name below it and type in a new name.



5. Click Finish. (Or click Scan More to scan additional images.)

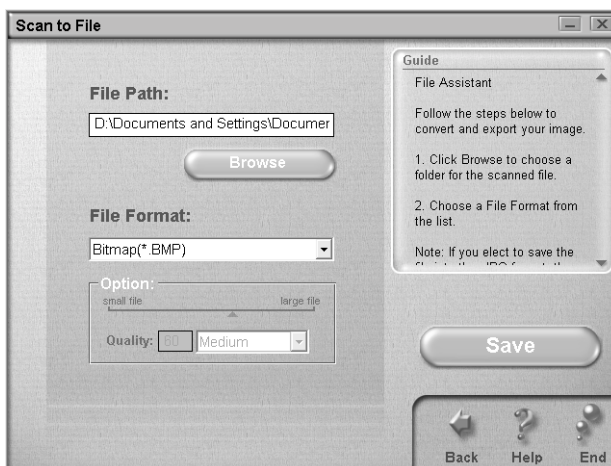



6. Select a folder and file format, then click Save to save your file.



# One-Touch Scanning

You can use your  Scan button to automatically scan a photo into an imaging application, scan a document to convert it into editable text, or scan to e-mail, fax, or a photo sharing web site.

The following example explains how to set up the  Scan button so you can scan files to upload to the EPSON PhotoCenter<sup>SM</sup> photo sharing web site. If you don't have an EPSON PhotoCenter account, you can sign up for one on the Internet at <http://photo.epson.com>. EPSON PhotoCenter is a great way to share photos with friends and family with your own private Internet photo albums. After you've signed up, follow the steps below.

1. Connect to the Internet.
2. Place the photo face-down on the glass, in the top, left corner.
3. Double-click the  EPSON Smart Panel icon on your desktop.

You'll need to go through the scanning process manually once, to set the defaults for your automatic scans.

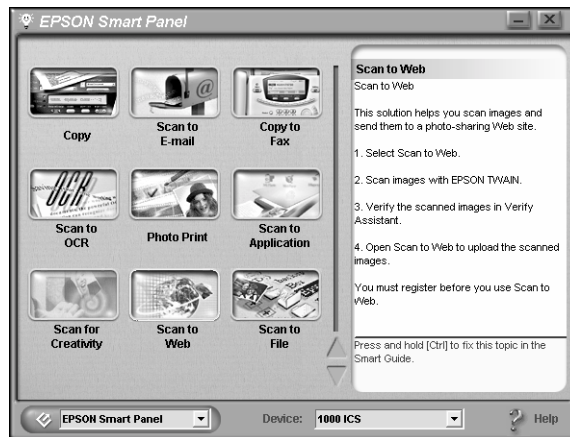

4. Click the Scan to Web button.

Smart Panel starts EPSON TWAIN, which automatically scans your document.

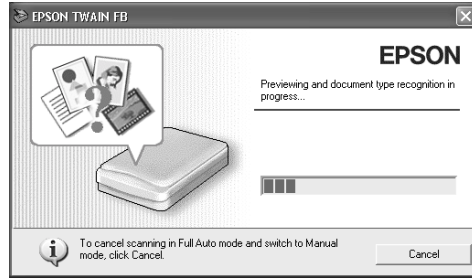

5. In the next screen, double-click a photo to make sure it scanned properly. To rename the image, click the file name below it and type in a new name.
6. When you see the upload screen, enter your account name and password, then click Upload. Scan to Web uploads the photo.

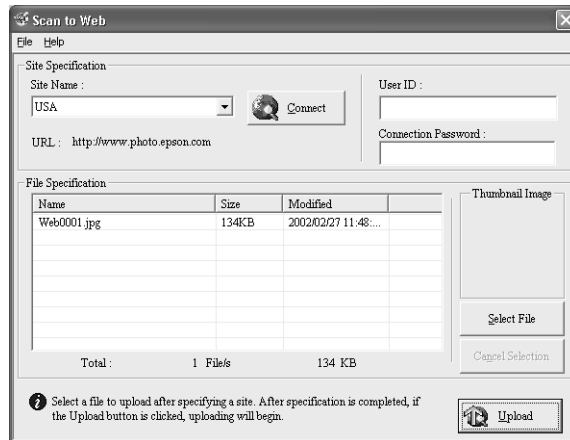

Now you are ready to use the  Scan button to automatically scan your photos so you can upload them to the EPSON PhotoCenter site.

7. Close the Scan to Web window and the EPSON Smart Panel window.
8. Place a new photo on the glass and press the  Scan button.

Your image is scanned, then Scan to Web opens with your file, ready for uploading.

9. Click Upload to upload your photo.

Connect to the EPSON PhotoCenter site to view, organize, and edit your photos at any time.

# Advanced Scanning With EPSON TWAIN

Scans can be performed from within a TWAIN-compliant host application—the application into which you plan to import the scan, such as Adobe® Photoshop® or EPSON Smart Panel. You have to start this application before you can access EPSON TWAIN, the scanner driver for your EPSON 1000 ICS. Then you need to select the EPSON TWAIN driver as the source (the steps may vary, depending on your application).

1. Start your application.
2. Select the scanner source. Open the File menu and choose Select Source, Import, or Acquire.

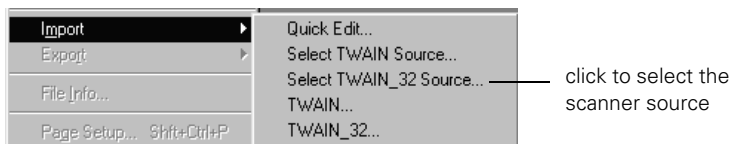

3. Select EPSON TWAIN FB and click Select or OK.

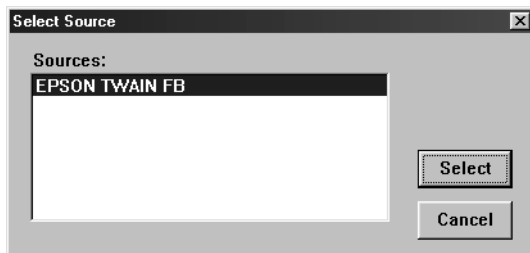

4. Start EPSON TWAIN for scanning. Open the File menu and choose Import or Acquire and if necessary, select TWAIN\_32 or EPSON TWAIN FB.

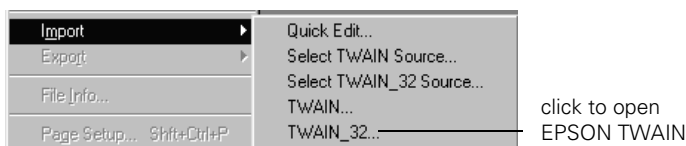

If your computer fails to recognize the EPSON 1000 ICS, you won't see EPSON TWAIN when you try to select a scanner source from your host application. In addition, an error message may appear. If this happens, turn off your computer and scanner, and then turn the scanner back on. Then restart the computer.

5. Click Cancel when you see the following screen.

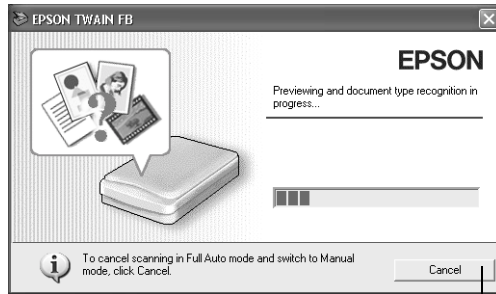

click Cancel

6. On the next screen, click the Manual mode button.

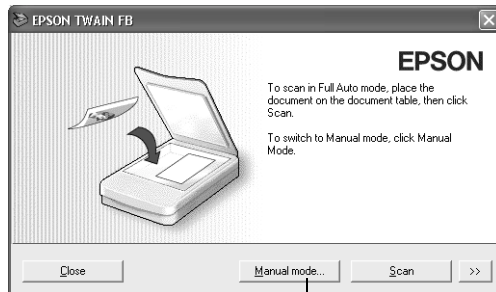

click Manual mode

7. You see the EPSON TWAIN settings dialog box:

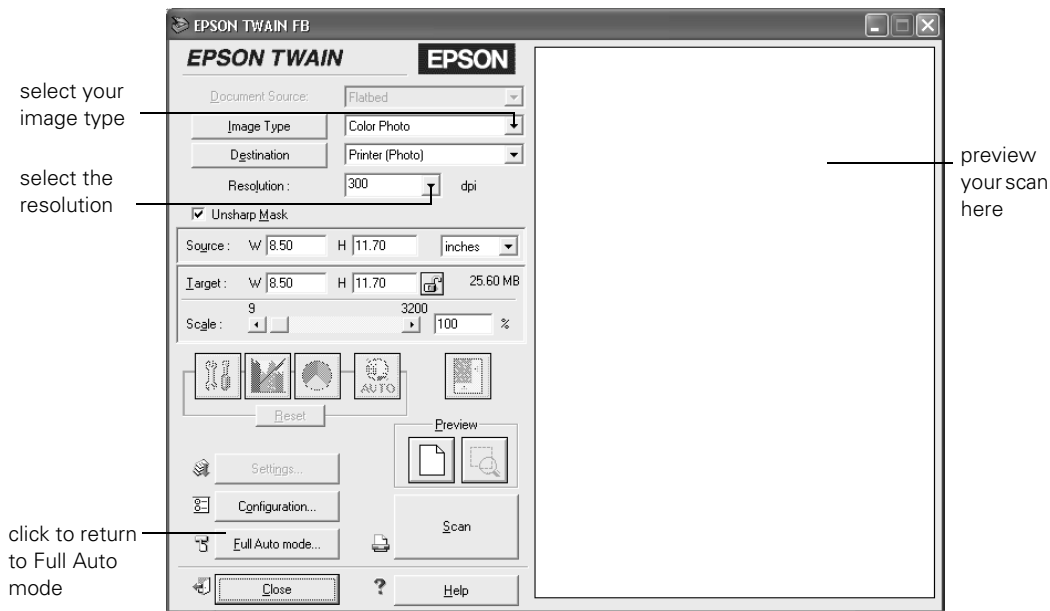

8. Make the changes you want to adjust the image, then click the Scan button.



The most important thing to remember when scanning is to select the correct image type and best resolution for your scan. For more detailed information on making settings in your EPSON TWAIN driver, see your electronic *Reference Guide*, as described on page 2.

To switch back to Full Auto mode, click the Full Auto mode button. Your image will be automatically scanned and optimized.



Depending on the image you want to scan, you may not get the expected scanned image. In this case, scan the image in the Manual mode.

# Maintenance

This section gives you basic maintenance instructions and tells you how to transport your EPSON 1000 ICS safely.

## Cleaning the Print Head

If your printouts are unexpectedly light, or dots or lines are missing, you may need to clean the print head. This unclogs the nozzles so they can deliver ink properly. Print head cleaning uses ink, so clean it only if quality declines.



When you don't turn on your EPSON 1000 ICS for a long time, the print quality can decline. It's a good idea to turn on your EPSON 1000 ICS at least once a month to maintain good print quality.

1. Make sure the EPSON 1000 ICS is turned on but not printing, and the Error light is off. (If the Error light is flashing or on, you may need to replace an ink cartridge; see page 27 for details.)

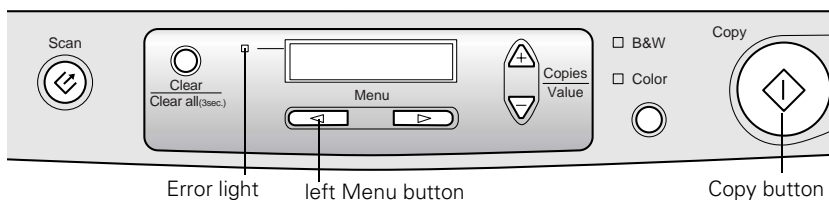



2. Press the left Menu button on the control panel several times until you see Cleaning and then press the  Copy button.

Cleaning takes about 30 seconds, during which the EPSON 1000 ICS makes some noise and the  Operate light flashes.



Never turn off the EPSON 1000 ICS while the  Operate light is flashing, unless the EPSON 1000 ICS hasn't moved or made noise for more than 5 minutes.

3. When the  Operate light stops flashing, run a nozzle check to confirm the print head nozzles are clean: make sure paper is loaded in the EPSON 1000 ICS and press the left Menu button several times until you see Nozzle Check, and then press the  Copy button. The nozzle check pattern prints.
4. Examine the nozzle check pattern you print. It should look something like this:

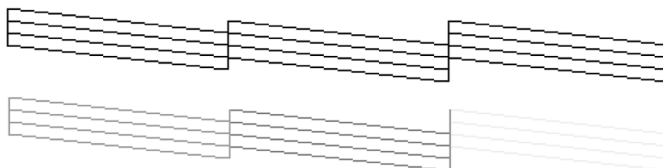

Each staggered horizontal and straight vertical line should be complete, with no gaps in the dot pattern. If your printout looks okay, you're done.

5. If you see any white lines or gaps, clean the print head again.

If you don't see any improvement after cleaning three or four times, check the solutions beginning on page 39. You can also turn the EPSON 1000 ICS off and wait overnight—this allows any dried ink to soften—and then try cleaning the print head again.

---

## Aligning the Print Head

If your printouts contain misaligned vertical lines, you may need to align the print head. You can align the print head directly from the EPSON 1000 ICS control panel.



Load plain paper that's at least 8.27 inches (210 mm) wide to prevent ink from spraying inside the EPSON 1000 ICS and smudging your printouts.

1. Make sure the EPSON 1000 ICS is turned on and plain letter-size paper is loaded.

2. Press the left Menu button on the control panel several times until you see Print Head Alignment and then press the  Copy button to print a test page.

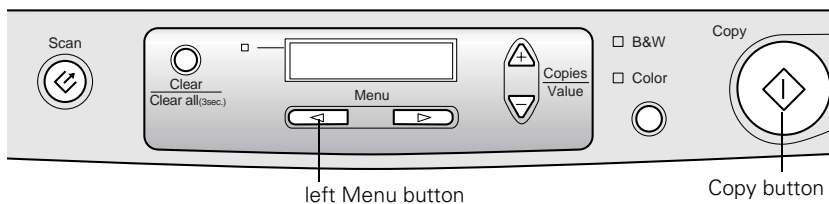

3. On the test page, select the pattern with the two vertical lines most precisely printed on top of each other. You may need to use a magnifying glass or loupe.

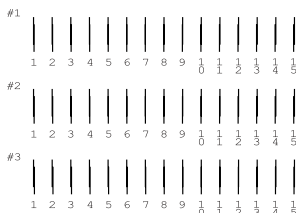

Select one pattern each for rows 1, 2, and 3.

4. Use the Value buttons to select the number of the best pattern for the first row, then press the  Copy button. Repeat this step for the second and third rows.
5. If pattern 8 was the best aligned in each row, your print head is properly aligned. If other patterns were better aligned, repeat the steps above.

---

## Replacing an Ink Cartridge

If the Error light on the EPSON 1000 ICS is flashing and you see an ink low or ink out message, or you see that your ink levels are low in the status monitor that appears on your screen, you may need to replace one of the cartridges.



## Checking the Ink Supply

To check your ink supply, do one of the following:

- Press one of the Menu buttons on the EPSON 1000 ICS control panel several times until you see Ink Levels. This gives you an approximate percentage of ink remaining in each cartridge.
- In Windows, double-click the  printer icon on your taskbar (in the lower right corner of your screen). If one of your cartridges is low, you'll see a window like this one:

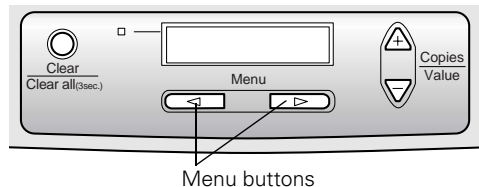

If you have multiple printers installed, you may not see this window. To get the ink status, access your printer settings as described on page 10, click the Utility tab, and then click EPSON Status Monitor.

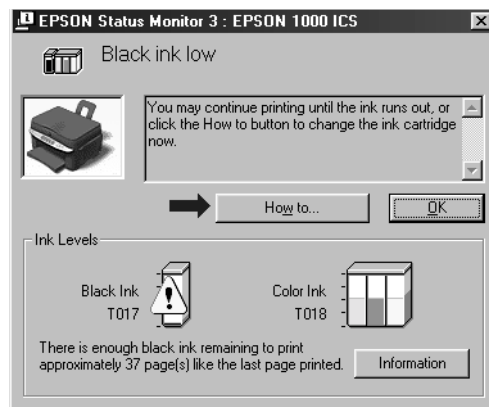

When a cartridge is more than six months old, you may need to replace it if printouts don't look their best. If the quality doesn't improve after cleaning and aligning the print head, you can replace the cartridge.

## Purchasing Ink Cartridges

Use EPSON ink cartridges within six months of installing them and before the expiration date on the package. Look for ink cartridge packages labelled T017 (black) or T018 (color).



To ensure good results, use genuine EPSON ink cartridges and do not refill them. Other products may cause damage to your EPSON 1000 ICS not covered by EPSON's warranty.

When you need new ink cartridges, contact your dealer, or call the EPSON Store<sup>SM</sup> at (800) 873-7766 or visit [www.epsonstore.com](http://www.epsonstore.com) (U.S. sales only). In Canada, please call (800) 463-7766 for dealer referral.

## Ink Cartridge Precautions



Keep ink cartridges out of the reach of children and do not drink the ink.

If ink gets on your hands, wash them thoroughly with soap and water. If ink gets in your eyes, flush them thoroughly with water.

To avoid damaging the EPSON 1000 ICS, never move the print head by hand.

You cannot print if either ink cartridge is empty. Leave the empty cartridge installed in the EPSON 1000 ICS until you have obtained a replacement. Otherwise the ink remaining in the print head nozzles may dry out.

## Removing and Installing Ink Cartridges

Be sure you have a new ink cartridge before you begin. Once you start the ink cartridge replacement procedure, you must complete all the steps in one session.

1. Make sure the EPSON 1000 ICS is turned on and not printing. The control panel tells you which ink cartridge is low or empty.
2. Press the left Menu button several times until you see Change Cartridge and then press the  Copy button. The ink cartridges move to the center.

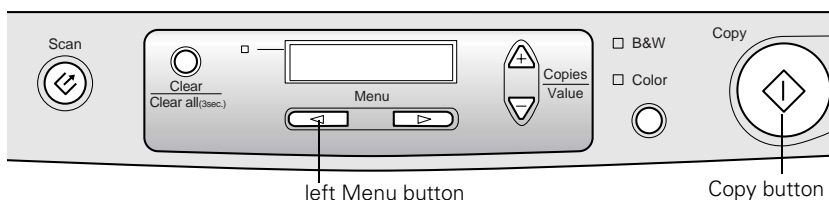

3. Press the release button and lift up the scanner.

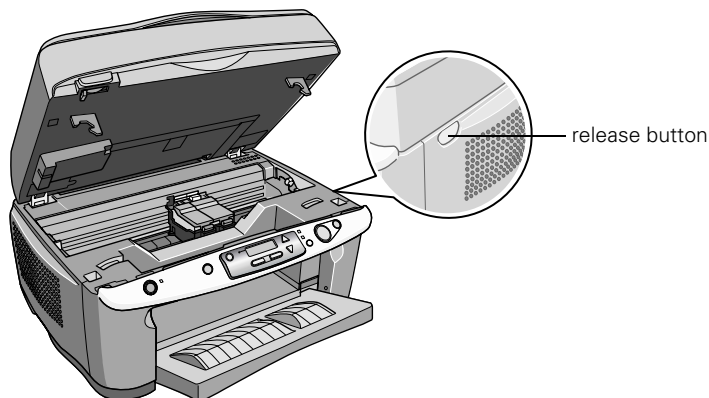

4. Pull up the ink cartridge clamp. (The color cartridge is on the right and the black is on the left.) The cartridge rises up from its holder.

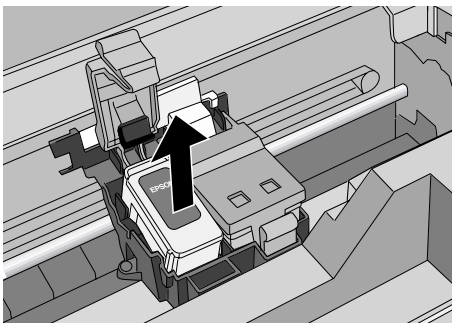

5. Lift the cartridge out of the EPSON 1000 ICS and dispose of it carefully.
6. Unwrap the new ink cartridge. Then remove *only* the yellow tape seal on top.



You must remove the yellow tape from the top of the cartridge or you will permanently damage it.

Don't touch the green circuit board on the back of the cartridge; you may inhibit normal operation and printing.

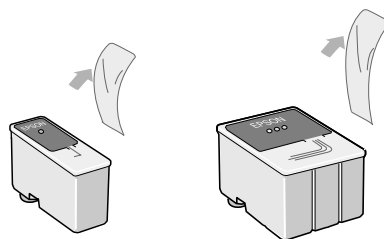

black cartridge

color cartridge

7. Tilt the new cartridge toward you slightly as you insert it. Lower the cartridge so that the tabs rest on the hooks.

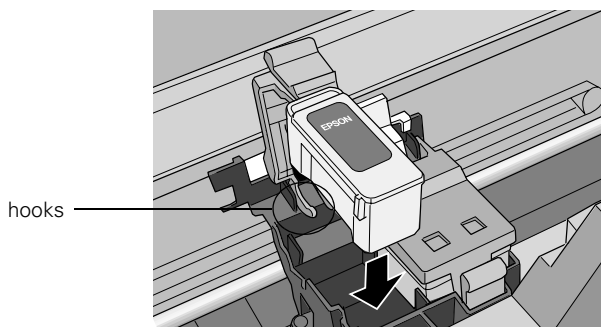

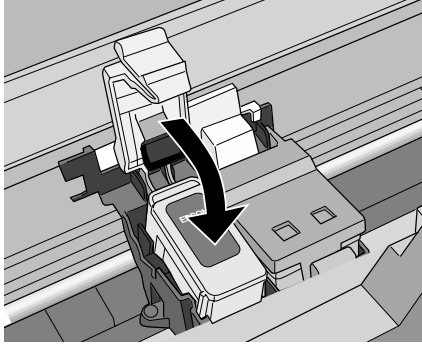

Don't place the cartridge under the hooks; you may damage the clamp when you close it.

8. Press down firmly on the ink cartridge clamp until it snaps in place.



If you need to replace the other ink cartridge, repeat steps 4 through 8 before continuing with step 9.

9. Carefully lower the scanner and press it down until it clicks into place. Press the  Copy button. The EPSON 1000 ICS begins charging the ink delivery system. The  Operate light flashes and the EPSON 1000 ICS makes noise. Charging takes about half a minute. When it's finished, the  Operate light stops flashing and stays on, and the Error light goes out.



Never turn off the EPSON 1000 ICS while the  Operate light is flashing, unless the EPSON 1000 ICS hasn't moved or made noise for more than 5 minutes.

---

## Cleaning the EPSON 1000 ICS

To keep your EPSON 1000 ICS operating at its best, you should clean it periodically.

1. Turn off the EPSON 1000 ICS, unplug the power cord, and disconnect the USB cable.
2. Remove all paper, then use a soft brush to clean any dust or dirt from the sheet feeder.
3. Clean the exterior with a soft, damp cloth.

4. Press the release button, lift up the scanner, then clean ink out of the interior with a soft, damp cloth.

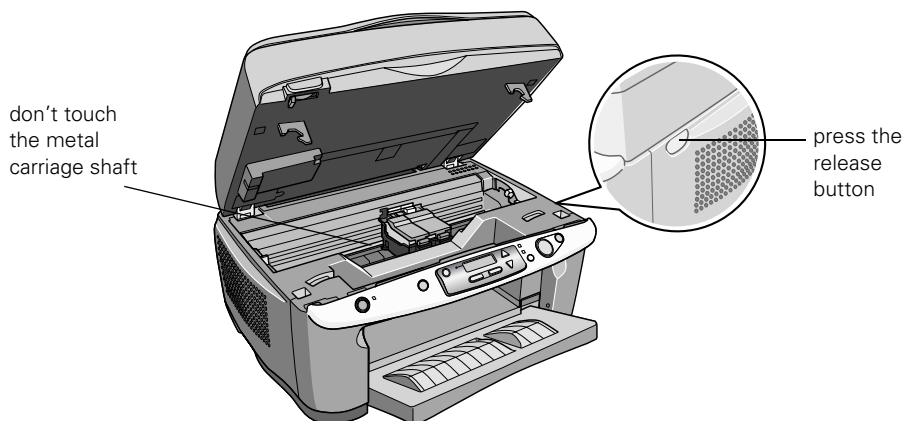

5. Carefully lower the scanner and press it down until it clicks into place.
6. If the document table glass gets dirty, clean it with a soft, dry, lint-free cloth. Paper towels are not recommended for cleaning the glass. If the glass is stained with grease or other hard-to-remove material, use a small amount of glass cleaner on a soft cloth to remove it. Wipe off any remaining liquid with a dry cloth.
7. Be sure there's no dust on your document table. Dust can cause white spots to appear in your scanned image.



Don't touch the gears inside the EPSON 1000 ICS.



Be careful not to wipe the metal carriage shaft.

Never use a hard or abrasive brush, or alcohol or thinner for cleaning; they can damage the printer components, document table, and case.

Don't get water on the components and don't spray lubricants or oils inside the EPSON 1000 ICS.

Don't use any cleaning sheets included with special paper; they may jam inside the EPSON 1000 ICS.

# Transporting the EPSON 1000 ICS

If you move your EPSON 1000 ICS some distance, you need to prepare it for transportation in its original box or one of a similar size.



To avoid damage, always leave the ink cartridges installed when transporting the EPSON 1000 ICS.

1. Press the  Operate button to turn on the EPSON 1000 ICS and wait until the scanner carriage moves to the home position (toward the left side) and the print head locks in the far right position, then turn it back off.
2. Unplug the power cord from the electrical outlet. Then disconnect the USB cable.
3. Remove any paper from the EPSON 1000 ICS and remove the paper support.
4. Press the release button and lift up the scanner.
5. If you still have the packing insert, slide it down into the area beside the ink cartridge holder and tape it to the EPSON 1000 ICS case. If you don't have the insert, just tape the cartridge holder to the EPSON 1000 ICS case.

move the transportation lock to the locked position (right)

tape the ink cartridge holder to the EPSON 1000 ICS case

release button

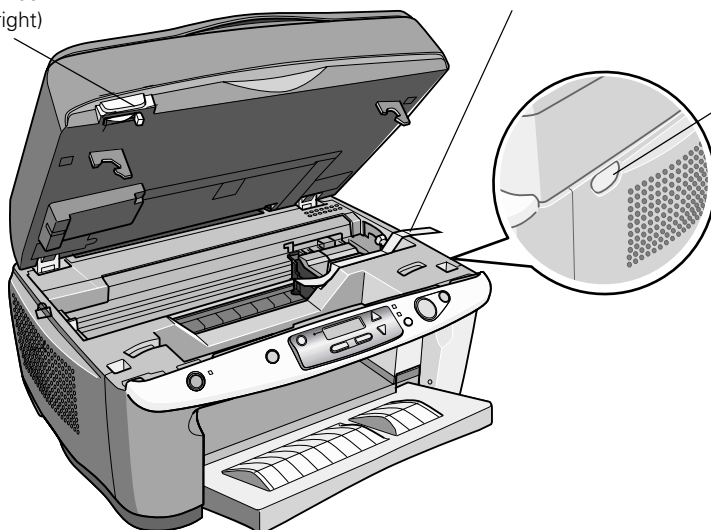



Be sure to remove the tape and packing insert after installing the EPSON 1000 ICS in its new location.

6. Slide the transportation lock right to the locked position.
7. Push the scanner down carefully until it clicks back into place, then close the output tray.
8. Repack the EPSON 1000 ICS and its attachments in the original box using the protective materials that came with them.

Keep the EPSON 1000 ICS level as you transport it.

After transporting the EPSON 1000 ICS, remove the tape securing the print head, unlock the transportation lock, and make a test copy. If you notice a decline in quality, clean the print head (see page 25); if output is misaligned, align the print head (see page 26).

# Problem Solving

This section gives you the basics for diagnosing and solving problems.

- First see “Diagnosing Problems” on page 37 to help determine what the cause of the problem may be.
- Then see “Problems and Solutions” on page 39 for solutions to common setup, software, print quality, paper feeding, or other problems.



It's a good idea to check EPSON's web site periodically for possible updates to your software. Visit <http://support.epson.com> and check the section for your product to see if there is new software available for downloading to your computer.

---

## Identifying Parts

If you need help identifying the parts of the unit, refer to the illustrations here and on the next page:

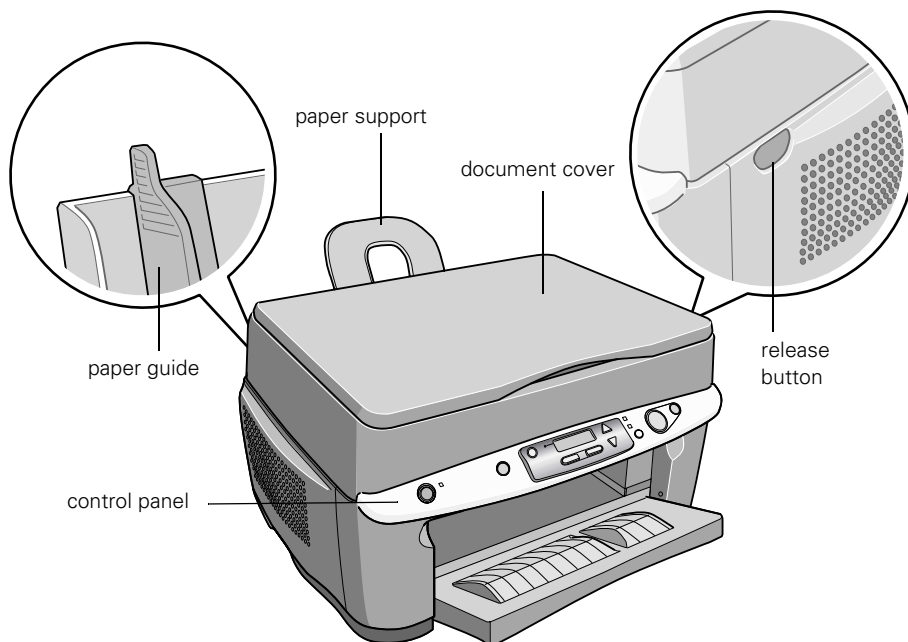



transportation lock  
(unlock before using)

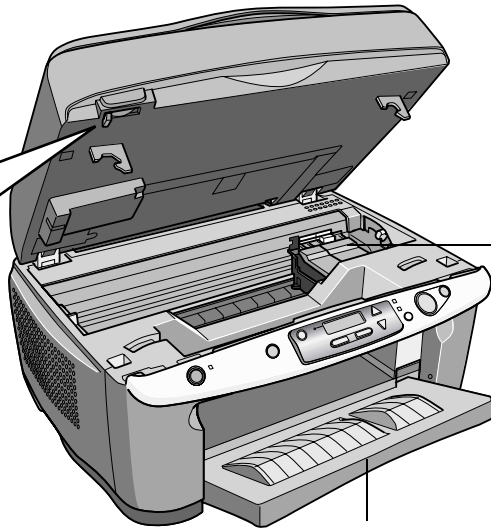
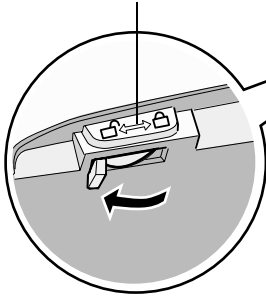

ink cartridge holders  
(do not remove)

output tray

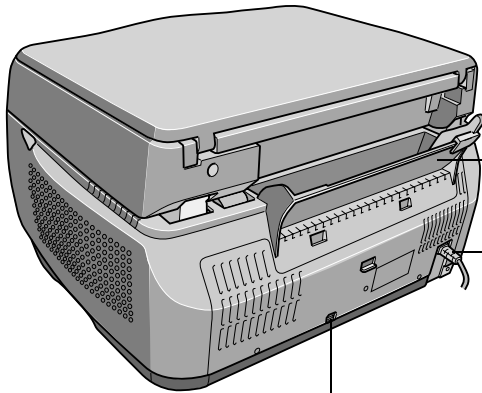

sheet feeder

power cord

USB port

# Diagnosing Problems



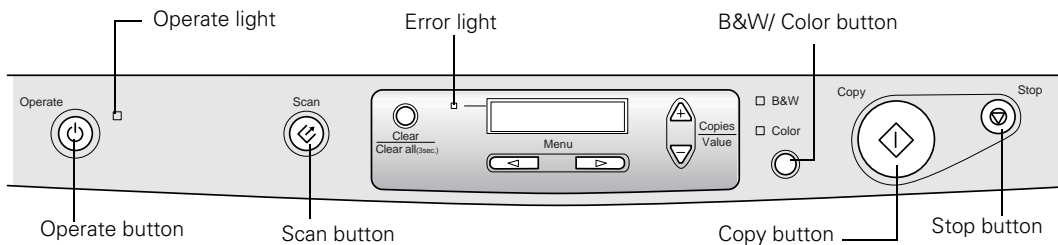

You can diagnose some problems by checking the printer's control panel, as described below, or printing a nozzle check, as described on page 39.

## Checking the Control Panel Error Messages



Here is a list of control panel error messages and what you can do when you see them.

Error Message	Solution
No color and black ink cartridge --> Press the Copy button to install new color (T018) and black (T017) ink cartridges.	There are no ink cartridges in the EPSON 1000 ICS or they are installed incorrectly. See page 29 to install ink cartridges.
No black ink cartridge --> Press the Copy button to install a new black ink cartridge (T017).	There is no black ink cartridge in the EPSON 1000 ICS or it is installed incorrectly. See page 29 to install an ink cartridge.
No color ink cartridge --> Press the Copy button to install a new color ink cartridge.	There is no black ink cartridge in the EPSON 1000 ICS or it is installed incorrectly. See page 29 to install an ink cartridge.
Color and black ink out --> Press the Copy button to begin replacing the color (T018) and black (T017) ink cartridges.	Both ink cartridges have run out of ink. See page 29 to replace both ink cartridges.
Black ink low	Obtain a replacement ink cartridge.
Color ink low	Obtain a replacement ink cartridge.
Black ink out --> Press the Copy button to begin replacing the black ink cartridge (T017).	The black ink cartridge has run out of ink. See page 29 to replace the ink cartridge.

Error Message	Solution
Color ink out -- > Press the Copy button to begin replacing the color ink cartridge (T018).	The color ink cartridge has run out of ink. See page 29 to replace the ink cartridge.
Ink cartridge error -- > Press the Copy button to begin replacing the ink cartridge.	There is something wrong with the ink cartridge. See page 29 to replace the ink cartridge.
Ink cartridge is not EPSON genuine ink; therefore quality may suffer. Press the Copy button to continue copying, or press the Clear button to suppress this message and to continue copying.	Press the  Copy button to continue printing or copying. Press the Clear button to prevent this message from reappearing.
Paper jam -- > Press the Copy button and clear the paper jam by hand if necessary.	Paper is jammed or has misfed. Press the  Copy button to clear the jam. If it is still jammed, see page 43.
Paper out -- > Load paper in the sheet feeder and press the Copy button.	Load paper in the sheet feeder, then press the  Copy button to continue printing.
Scanner unit open -- > Close the scanner unit.	Carefully lower the scanner and press it down until it clicks securely into place.
Scanner error -- > Turn off then on. If necessary call your service center.	Press the  Operate button to turn off the EPSON 1000 ICS. Check the transportation lock and unlock it, if necessary (see page 33). Turn on your EPSON 1000 ICS again. If the error message still appears, contact your dealer or EPSON as described on page 49.
Printer error -- > Turn off then on. If necessary call your service center.	Press the  Operate button to turn off the EPSON 1000 ICS, then press it to turn it back on. If the message still appears, contact your dealer or EPSON as described on page 49.

## ***Printing a Nozzle Check***

You can print a nozzle check to determine whether a problem comes from the EPSON 1000 ICS itself or some other source.

1. Make sure letter-size or larger paper is loaded in the sheet feeder.
2. Press the left Menu button on the control panel until you see Nozzle Check.
3. Press the  Copy button.

If the check page prints, the problem probably lies in your software settings, the interface cable, or your computer. If the check page doesn't print, you may have a problem with your printer. Try the suggestions in "Problems and Solutions" below.

---



## **Problems and Solutions**

Below are some troubleshooting tips for your EPSON 1000 ICS and its software.

### ***Setup and Software Installation Problems***

---

#### **The EPSON 1000 ICS makes noise after ink cartridge installation.**

- The first time you install ink cartridges, the EPSON 1000 ICS must charge its ink delivery system. Wait until charging finishes (the  Operate light stops flashing) before you turn off the EPSON 1000 ICS or it may charge improperly and use excess ink the next time you turn it on. If the EPSON 1000 ICS stops moving or making noise, but the  Operate light is still flashing after 5 minutes, turn it off. If the light is still flashing when you turn it back on, see "Where To Get Help" on page 49.
- Make sure the ink cartridge clamps are locked down completely and that no packing material remains in the printer. Turn off the printer, wait a moment, then turn it back on to clear the error.

---

**You cancelled the software installation before it was complete, or you connected the EPSON 1000 ICS before starting the software installation.**

Your EPSON software may be incorrectly installed. See page 48 to uninstall your software. Make sure you follow the steps on your *Start Here* poster carefully when you reinstall your software. You need to connect the EPSON 1000 ICS at the correct time during installation so that it is detected by the driver.

---

**You're having problems installing the software.**

- Make sure your system meets the requirements beginning on page 51. Close your other applications, including any screen savers and virus protection software and install again.
- Make sure that the Universal Serial Bus (USB) Controller is working properly in Device Manager; see your computer documentation. If it is not working, contact your computer dealer.
- If you see an error message or the software doesn't install correctly on Windows XP or Windows 2000, you may not have software installation privileges.
- If you're printing over a network, see your electronic *Reference Guide* for instructions on configuring your EPSON 1000 ICS for use on a network.
- It takes several minutes to install the software. Don't cancel the installation or open any other programs during the installation process.

## ***Printing and Copying Problems***

---

**Only the  Operate light is on, but nothing prints.**

- Make sure the USB cable is connected securely and that the cable meets the system requirements on page 51.
- Run a nozzle check as described on page 39. If the check page prints, make sure your EPSON 1000 ICS software is installed correctly.
- If you're printing on a network, you need to set up your EPSON 1000 ICS for network printing, as described in your electronic *Reference Guide*.

---

**It sounds like the EPSON 1000 ICS is printing, but nothing prints.**

Make sure the print head nozzles are not clogged. To clean the print head, see page 25.

---

**Your EPSON 1000 ICS makes noise when you turn it on or after it has been sitting for a while.**

Your EPSON 1000 ICS is performing routine maintenance.

---

**Printing or copying is too slow.**

Make sure your system meets the requirements listed on page 51. If you're printing a high-resolution image, you need more than the minimum requirements listed.

You may also need to:

- Clear space on your hard disk or run a defragmentation utility.
- Close open applications that you're not using.
- Increase your system's memory (RAM).

For the fastest printing, try the following:

- Choose Black ink in your printer driver (see page 9) or the B&W setting on the Copy control panel (see page 4) if your document doesn't include color.
  - In the printer software's Advanced dialog box, turn High Speed on.
- 

**The margins are incorrect.**

- Make sure the paper settings in your printer software are correct for your paper size. See the electronic *Reference Guide* (as described on page 2) for instructions.
  - Check your software documentation for instructions on selecting the correct margins for your paper size. The margins must be within the printable area of the page. See "Printer Specifications" in your electronic *Reference Guide* (as described on page 2) for more information.
- 

**The printer prints blank pages.**

- Make sure the paper settings in the printer software are correct for your paper size. See your electronic *Reference Guide* as described on page 2.
- The print head nozzles may need cleaning; see page 25 for instructions.

## Scanning Problems

---

**Your system doesn't recognize the EPSON 1000 ICS.**

Make sure your EPSON 1000 ICS is connected to your computer and plugged into a power source.

---

**The fluorescent lamp isn't on.**

- The EPSON 1000 ICS has a power saving function (sleep mode); it comes on when you start scanning.
  - Make sure the EPSON 1000 ICS is plugged into a power outlet.
- 

**The EPSON 1000 ICS doesn't scan.**

- Wait until the fluorescent lamp stays on (ready for scanning). You may need to preview your scan to make the lamp come on.
  - If you are using a USB hub, try connecting the EPSON 1000 ICS directly to the computer's USB port. Use only the USB cable that came with your EPSON 1000 ICS.
  - If you see your EPSON 1000 ICS in the Windows Control Panel, but you can't scan, uninstall and reinstall its software; see page 48.
- 

**The EPSON 1000 ICS scanning software doesn't work properly.**

- Make sure your computer meets the system requirements listed on page 51 and supports the software applications you're using.
- Check if your computer has enough memory for your software. If you're running other software at the same time, the computer may not have enough memory. (See your software and computer manuals.) Try closing any open applications, including screen savers and virus protection programs.
- If you are scanning a large image or scanning at a high resolution, your computer may not have enough memory to process the image.
- Check your software installation. If all else fails, uninstall your software, then reinstall it; see page 48.

## ***Problems with Paper Feeding***

---

**Too many copies are printing.**

Make sure that neither the Copies setting in your printer software, nor the Copies setting in your application is set for multiple copies.

---

**Paper doesn't eject fully or is wrinkled.**

- If the paper doesn't eject fully, you may have set the wrong paper size. Press the  Copy button to eject the paper. Then select the correct paper size in your application or printer software.
  - If it's wrinkled when it ejects, the paper may be damp or too thin.
- 

**Paper doesn't feed correctly or jams in the printer.**

- If paper doesn't feed, remove it from the sheet feeder. Then reload it against the right edge and slide the left edge guide against the other side.
- If paper jams, turn off your printer, open the cover, and remove any paper that's inside, including any small pieces that may have torn off. Carefully reload paper and press the  Copy button.
- If multiple pages feed at once, remove the paper and fan the edges of the stack to separate the sheets. Then carefully reload it.

If your paper loads incorrectly or jams frequently:

- Use new, smooth, high-quality paper, loaded printable side up.
- Don't load paper above the arrow mark on the left edge guide.
- Place the paper against the right edge and slide the left edge guide against it, but not too tightly.



## Print Quality Problems

---

**You see banding (light lines).**



- The print head nozzles may need cleaning; see page 25 for instructions.
- Make sure the Media Type setting matches the paper you loaded. See page 16 for guidelines.
- Make sure the printable side of the paper is face-up. It is usually whiter or shinier.
- The ink cartridges may be old or low on ink. To replace an ink cartridge, see page 27.
- Try using Automatic mode; see page 9.
- Run the Print Head Alignment utility; see page 26.

**Your printout is blurry or smeared.**



- Make sure your paper isn't damp, curled, or loaded face-down (the printable side should be face-up). If it's damp or curled, reload a new stack of paper.
- Use a support sheet with special paper or try loading your paper one sheet at a time.
- Make sure your paper meets the specifications listed in your electronic *Reference Guide*.
- Run the Print Head Alignment utility. See page 26 for instructions.
- Remove each sheet from the output tray as soon as it's finished printing.
- In the printer software's Advanced dialog box, turn High Speed off.

**Your printout is grainy.**

- Try using a higher quality paper.
- Set the Quality/Speed slider to Quality; see page 9 for details.
- Run the Print Head Alignment utility. See page 26 for instructions.
- You may need to increase the image resolution or print it in a smaller size; see your software documentation.

---

**Your printout is faint or has gaps.**



- The print head nozzles may need cleaning; see page 26 for instructions.
- The ink cartridges may be old or low on ink. To replace an ink cartridge, see page 27.
- Make sure the Media Type setting matches the paper you loaded. See page 16 for guidelines.
- Make sure your paper isn't damaged, old, dirty, or loaded face-down. If it is, reload a new stack of paper with the printable side up; it is usually whiter or shinier than the other side.

---

**You see wrong or missing colors.**

- Make sure the Ink setting is set to COLOR for color images and your application is set for color printing.
- The print head nozzles may need cleaning; see page 25 for instructions.
- The ink cartridges may be old or low on ink. To replace an ink cartridge, see page 27.
- If you're printing a high-resolution image, turn off PhotoEnhance, as described on page 11. Also check if you're using a special effect that alters image colors, such as Sepia.
- Try using Automatic mode. See page 9 for instructions.
- Your printed colors can never exactly match your on-screen colors. However, you can use a color management system to get as close as possible. For information, see your electronic *Reference Guide* (as described on page 2).

---

**You see incorrect characters.**

- Make sure the USB cable is securely connected and that the cable meets the system requirements on page 51. Then try printing again.
- Make sure your EPSON 1000 ICS is selected in your application, or as the Windows default printer.
- If you're using a switch box with your EPSON 1000 ICS, connect the EPSON 1000 ICS directly to your computer and try printing again.

---

**The image size or position is incorrect.**

Make sure the paper and/or layout options are set correctly. See your electronic *Reference Guide* (as described on page 2) for more information.

---

**The image is inverted, as if viewed in a mirror.**

Turn off Flip Horizontal in the printer software or the mirror setting in your application software. (If you're printing on EPSON Iron-On Cool Peel Transfer Paper, the image should be inverted so it looks correct when it's ironed on.)

## ***Scan Quality Problems***

---

**Your scanned image is blurry or distorted.**

- Check the position and condition of your document. Make sure the document is placed flat against the document table glass. If only part of the image is blurred, part of your document may be wrinkled or warped.
  - Try scanning at a higher resolution. See page 22 for recommended settings.
  - Make sure the document table glass is clean; see page 31.
  - Make sure the EPSON 1000 ICS is not tilted or placed on an unstable or uneven surface.
- 

**Your image is too dark.**



- Try adjusting the brightness with your application software. Also check the brightness and contrast values of your display screen.
- The dark area around film, such as the frame of the film holder, is perceived as white—altering the exposure of the scanning area and causing your scans to appear darker. Set the correct color by adjusting the marquee (frame border) so none of the film holder is selected. See your electronic *Reference Guide* (as described on page 2).

---

**The image does not look the same as the original.**

- Your software settings are not correct for your document type. Try different combinations of image settings using your scanner software.
- Because your monitor and printer use different technologies to represent colors, your printed colors cannot exactly match the colors you see on your screen. If you increase your monitor's color palette, you can view a greater range of colors.

---

**The edges of the document are not scanned.**



- The document table has non-readable areas around the edges. If your document extends beyond the limits marked on the document table edge guides, reposition your document so it is within the readable area.
- Check the position of your source document. Adjust your document's position so that the image is within the glass area.

---

**The scanner doesn't recognize your image type when scanning in Full Auto mode.**

Try scanning the image again. If that doesn't work, scan in Manual mode (see page 22 for instructions).

---

**The file size is too big.**

Adjust your scan settings. Try selecting a lower resolution (dpi), saving the file in a different format, or scan only part of the image. 300 dpi is typically an adequate resolution for images that will be printed.

---

**The printed image is larger or smaller than the original size.**

You have changed the resolution or scaled your image. The image size settings in your software determine the size of the printed image.

---

**A dotted line appears in the image.**

- If this happens on both your screen and printout, clean the document table as described on page 31.
- If the line is just on your printout, you may need to clean your print head, see page 25.

# Uninstalling and Reinstalling Your Software

## For Windows XP or 2000 users:

1. Make sure your EPSON 1000 ICS is plugged in and connected to your computer.
2. In Windows XP, click Start, right-click My Computer, and then click Properties. In Windows 2000, right-click My Computer, and then click Properties.
3. In the System Properties dialog box, select the Hardware tab, then click Device Manager.
4. Click the plus (+) sign next to Other devices or Imaging devices. If a question (?) mark or an exclamation (!) mark appears next to the EPSON 1000 ICS name, right-click the name, and then select Uninstall.
5. Click Start > Programs or All Programs > EPSON Smart Panel > Uninstall EPSON Smart Panel and follow the instructions on the screen.
6. When the Smart Panel uninstall is complete, click Start > Settings > Control Panel or Start > Control Panel. Double-click Add/Remove Programs.
7. Choose EPSON Copy Utility, then click Add/Remove or Change/Remove and follow the instructions on the screen to remove the Copy Utility, then click OK.
8. Follow the installation steps on the *Start Here* poster to reinstall your software.



## For Windows Me or 98 users:

1. Disconnect the USB cable from the EPSON 1000 ICS.
2. Click Start > Programs > EPSON Smart Panel > Uninstall EPSON Smart Panel and follow the instructions on the screen.
3. When the Smart Panel uninstall is complete, click Start > Settings > Control Panel. Double-click Add/Remove Programs.
4. Choose EPSON Copy Utility, then click Add/Remove or Change/Remove and follow the instructions on the screen to remove the Copy Utility, then click OK.
5. Follow the installation steps on the *Start Here* poster to reinstall your software.

# Where To Get Help

## *EPSON Technical Support*

EPSON provides technical assistance 24 hours a day through the electronic support services and automated telephone services listed in the following table:

Service	Access
World Wide Web	From the Internet, you can reach EPSON Support at <a href="http://support.epson.com">http://support.epson.com</a> . At this site, you can download drivers and other files, look at product documentation, access troubleshooting information, and receive technical advice through e-mail.
Automated Telephone Services	A variety of automated help services are available 24 hours a day, seven days a week. To use these services, you must have a touch tone telephone and call (800) 922-8911. Your SoundAdvice <sup>SM</sup> Express Code is 70380. Use this code to quickly select the EPSON 1000 ICS in SoundAdvice.

To speak to a technical support representative, dial:

- U.S.: (562) 276-4382, 6 AM to 6 PM, Pacific Time, Monday through Friday
  - Canada: (905) 709-3839, 6 AM to 6 PM, Pacific Time, Monday through Friday
- Toll or long distance charges may apply.

Before you call, please have the following information ready:

- Product name (EPSON 1000 ICS)
- Product serial number (located on the back)
- Proof of purchase (such as a store receipt) and date of purchase
- Computer configuration
- Description of the problem

You can purchase ink cartridges, paper, manuals, and accessories from EPSON. Call the EPSON Store at (800) 873-7766 or visit [www.epsonstore.com](http://www.epsonstore.com) (U.S. sales only). In Canada, please call (800) 463-7766 for dealer referral.

## ***Software Technical Support***

<b>Software</b>	<b>Telephone</b>	<b>Fax</b>	<b>Online and E-mail</b>
EPSON TWAIN driver	U.S. (562) 276-4382  Canada (905) 709-3839	(800) 922-8911 fax-on-demand system	<a href="http://support.epson.com">http://support.epson.com</a>
EPSON Smart Panel	(510) 445-8616	(510) 445-8601	<a href="mailto:tech@newsoftinc.com">tech@newsoftinc.com</a>
ArcSoft PhotoImpression	(510) 440-9901 8:30 AM to 5:30 PM, PST, Monday through Friday	(510) 440-1270	<a href="http://www.arcsoft.com">www.arcsoft.com</a> <a href="mailto:support@arcsoft.com">support@arcsoft.com</a>

# Requirements and Notices

This chapter includes system requirements, safety instructions, legal notices, and other important information.

## Windows System Requirements

To use your EPSON 1000 ICS and its software, your system should have:

- An IBM® compatible PC with the following operating system requirements

Operating system	Minimum requirements	Recommended
Windows XP	Pentium® 233 processor 64MB RAM SVGA display	Pentium 300 MHz processor, or faster 128MB RAM, or more SVGA display, or better
Windows 2000	Pentium 166 processor 64MB RAM VGA display	
Windows Me	Pentium 166 processor 64MB RAM VGA display	
Windows 98	Pentium 166 processor 64MB RAM VGA display	

- Microsoft Windows XP, Windows 2000, Windows Me, or Windows 98
- At least 300MB of free hard disk space
- Double-speed (2X) CD-ROM drive (quad-speed [4X] or faster recommended) or DVD drive for installing the software
- Windows-compliant USB port and a shielded USB “AB” cable from Series A (computer) to Series B (printer), up to 6.5 ft. (2 meters) long.



Using an improperly shielded USB cable—especially a cable more than 6.5 ft. (2 meters) long—may cause the printer to malfunction.



---

# ENERGY STAR Compliance

As an ENERGY STAR Partner, EPSON has determined that this product meets the ENERGY STAR guidelines for energy efficiency. The EPA ENERGY STAR office equipment program is a voluntary partnership with the computer and office equipment industry to promote the introduction of energy-efficient personal computers, monitors, printers, fax machines, and copiers in an effort to reduce air pollution caused by power generation.



---

## Important Safety Instructions

Before using your EPSON 1000 ICS, read the following safety instructions to make sure you use the EPSON 1000 ICS safely and effectively:

- Be sure to follow all warnings and instructions marked on the EPSON 1000 ICS.
- Use only the type of power source indicated on the EPSON 1000 ICS's label.
- Connect all equipment to properly grounded power outlets. Avoid using outlets on the same circuit as air control systems or other high-load devices that regularly switch on and off.
- Place the EPSON 1000 ICS near a wall outlet where the plug can be easily unplugged.  
*Placez l'imprimante près d'une prise de contact où la fiche peut être débranchée facilement.*
- Do not let the power cord become damaged or frayed.
- If you use an extension cord with the EPSON 1000 ICS, make sure the total ampere rating of the devices plugged into the extension cord does not exceed the cord's ampere rating. Also, make sure the total ampere rating of all devices plugged into the wall outlet does not exceed the wall outlet's ampere rating.
- Avoid electrical outlets controlled by wall switches or automatic timers.
- Keep your EPSON 1000 ICS and computer system away from potential sources of electromagnetic interference, such as loudspeakers or cordless telephone base units.
- Avoid locations that are subject to rapid changes in heat or humidity, shocks or vibrations, or dust.
- Leave enough room around the EPSON 1000 ICS for sufficient ventilation.
- Do not place the EPSON 1000 ICS near a radiator or heating vent or in direct sunlight.
- Place the EPSON 1000 ICS on a flat, stable surface that extends beyond the EPSON 1000 ICS base in all directions. The EPSON 1000 ICS will not operate properly if it is tilted or at an angle. Leave enough space in front of the EPSON 1000 ICS for the paper to be fully ejected.
- Turn off and unplug the EPSON 1000 ICS before cleaning. Clean with a damp cloth only. Do not spill liquid on the EPSON 1000 ICS.



Always turn the EPSON 1000 ICS off using the ⏻ Operate button. The ⏻ Operate light flashes briefly and then goes out. Don't switch off the power strip, or unplug the EPSON 1000 ICS until the ⏻ Operate light is off.

- Do not block or cover the openings in the EPSON 1000 ICS's case or insert objects through the slots.
- Except as specifically explained in this manual, do not attempt to service the EPSON 1000 ICS yourself.
- Unplug the EPSON 1000 ICS and refer servicing to qualified service personnel under the following conditions:
- If the power cord or plug is damaged; if liquid has entered the EPSON 1000 ICS; if the EPSON 1000 ICS has been dropped or the case damaged; if the EPSON 1000 ICS does not operate normally or exhibits a distinct change in performance. Adjust only those controls that are covered by the operating instructions.
- Before transporting the EPSON 1000 ICS, make sure the print head is capped in the far right position and the ink cartridges are in place. Also make sure the scanner carriage is secured with the transportation lock.

## ***Ink Cartridge Safety Instructions***

- Leave the ink cartridges installed. Removing the cartridges can dehydrate the print head and may prevent the EPSON 1000 ICS from printing.
- Keep ink cartridges out of the reach of children and do not drink the ink.
- Be careful when you handle used ink cartridges; there may be ink remaining around the ink supply port. If ink gets on your skin, wash it off with soap and water. If it gets in your eyes, flush them immediately with water.
- Do not put your hand inside the EPSON 1000 ICS or touch the cartridge during printing.
- Do not move the print head by hand; otherwise you may damage the EPSON 1000 ICS.
- Install the ink cartridge immediately after you remove it from its package. Leaving the cartridge unpacked for a long time before use may result in reduced print quality.
- Do not use an ink cartridge beyond the date printed on the cartridge package. For best results, use up the ink cartridges within six months of first installing them.
- Store ink cartridges in a cool, dark place. Store each ink cartridge so that the bottom of its package faces down.
- After bringing an ink cartridge inside from a cold storage site, allow it to warm up at room temperature for at least three hours before using it.
- Do not remove or tear the label or shake an ink cartridge; this can cause leakage.
- Do not dismantle the ink cartridges or try to refill them. This could result in damage to the print head.
- Do not touch the green IC chip on the side of the cartridge. This may affect normal operation and printing.

- In this ink cartridge, the IC chip retains a variety of cartridge-related information, such as the amount of ink remaining, so that a cartridge may be removed and reinserted freely. However, each time a cartridge is inserted, some ink is consumed because the EPSON 1000 ICS automatically performs a reliability check.
- If you remove an ink cartridge for later use, protect the ink supply area from dirt and dust and store it in the same environment as the EPSON 1000 ICS. Note that there is a valve in the ink supply port, making covers or plugs unnecessary, but care is needed to prevent the ink from staining items that the cartridge touches. Do not touch the ink cartridge ink supply port or surrounding area.

---

## FCC Compliance Statement

### For United States Users

This equipment has been tested and found to comply with the limits for a Class B digital device, pursuant to Part 15 of the FCC Rules. These limits are designed to provide reasonable protection against harmful interference in a residential installation. This equipment generates, uses, and can radiate radio frequency energy and, if not installed and used in accordance with the instructions, may cause harmful interference to radio or television reception. However, there is no guarantee that interference will not occur in a particular installation. If this equipment does cause interference to radio and television reception, which can be determined by turning the equipment off and on, the user is encouraged to try to correct the interference by one or more of the following measures:

- Reorient or relocate the receiving antenna.
- Increase the separation between the equipment and receiver.
- Connect the equipment into an outlet on a circuit different from that to which the receiver is connected.
- Consult the dealer or an experienced radio/TV technician for help.

### WARNING

The connection of a non-shielded equipment interface cable to this equipment will invalidate the FCC Certification of this device and may cause interference levels which exceed the limits established by the FCC for this equipment. It is the responsibility of the user to obtain and use a shielded equipment interface cable with this device. If this equipment has more than one interface connector, do not leave cables connected to unused interfaces. Changes or modifications not expressly approved by the manufacturer could void the user's authority to operate the equipment.

### For Canadian Users

This Class B apparatus complies with Canadian ICES-003.

Cet appareil numérique de la classe B est conforme à la norme NMB-003 du Canada.

---

# Declaration of Conformity

According to 47CFR, Part 2 and 15 for: Class B Personal Computers and Peripherals; and/or CPU Boards and Power Supplies used with Class B Personal Computers:

We: EPSON AMERICA, INC.  
Located at: MS 3-13  
3840 Kilroy Airport Way  
Long Beach, CA 90806  
Telephone: (562) 290-5254

Declare under sole responsibility that the product identified herein, complies with 47CFR Part 2 and 15 of the FCC rules as a Class B digital device. Each product marketed is identical to the representative unit tested and found to be compliant with the standards. Records maintained continue to reflect the equipment being produced can be expected to be within the variation accepted, due to quantity production and testing on a statistical basis as required by 47CFR §2.909. Operation is subject to the following two conditions: (1) this device may not cause harmful interference, and (2) this device must accept any interference received, including interference that may cause undesired operation.

Trade Name: EPSON  
Type of Product: Multifunction printer  
Model: C132A

---

## Epson America, Inc. Limited Warranty

**What Is Covered:** Epson America, Inc. (“Epson”) warrants to the first retail purchaser that the EPSON product covered by this limited warranty statement, if purchased and used in the United States or Canada, conforms to the manufacturer’s specifications and will be free from defects in workmanship and materials for a period of one (1) year from the date of original purchase. Epson also warrants that the consumable ink cartridges enclosed with the product will perform to the manufacturer’s specified usage, which usage may expire before the expiration of the limited warranty for the EPSON product. For warranty service, you must provide proof of the date of original purchase.

**What Epson Will Do To Correct Problems:** Should your EPSON product prove defective during the warranty period, please call the EPSON Connection<sup>SM</sup> at (562) 276-4382 (U.S.) or (905) 709-3839 (Canada) for warranty repair instructions and return authorization. An Epson service technician will provide telephone diagnostic service to determine whether the product requires service. If service is needed, Epson will, at its option, exchange or repair the product without charge for parts or labor. If Epson authorizes an exchange for the defective unit, Epson will ship a replacement product to you, freight prepaid, so long as you use an address in Canada or the U.S. (excluding Puerto Rico and U.S. Possessions). Shipments to other locations will be made freight collect. You are responsible for securely packaging the defective unit and returning it to Epson within five (5) working days of receipt of the replacement. Epson requires a debit or a credit card number to secure the cost of the replacement product in the event that you fail to return the defective one. If your product is being repaired, Epson

will direct you to send your product to Epson or its authorized service center, where the product will be fixed and sent back to you. You are responsible for packing the product and for all costs to and from the Epson authorized service center. When warranty service involves the exchange of the product or a part, the item replaced becomes Epson property. The replacement product or part may be new or refurbished to the Epson standard of quality, and, at Epson's option, may be another model of like kind and quality. Epson's liability for replacement of the covered product will not exceed the original retail selling price of the covered product. Exchange products and parts assume the remaining warranty period of your original product covered by this limited warranty.

**What This Warranty Does Not Cover:** This warranty covers only normal use in the United States and Canada. This warranty is not transferable and will not apply to products purchased from an end user. This warranty does not cover any color change or fading of prints or reimbursement of materials or services required for reprinting. This warranty does not cover damage to the EPSON product caused by parts or supplies not manufactured, distributed or certified by Epson. This warranty does not cover ribbons, ink cartridges or third party parts, components, or peripheral devices added to the EPSON product after its shipment from Epson, e.g., dealer or user-added boards or components. Epson is not responsible for warranty service should the Epson label or logo or the rating label or serial number be removed or should the product fail to be properly maintained or fail to function properly as a result of misuse, abuse, improper installation, neglect, improper shipping, damage caused by disasters such as fire, flood, and lightning, improper electrical current, software problems, interaction with non-Epson products, or service other than by an Epson Authorized Servicer. If a claimed defect cannot be identified or reproduced, you will be held responsible for the costs incurred.

THE WARRANTY AND REMEDY PROVIDED ABOVE ARE EXCLUSIVE AND IN LIEU OF ALL OTHER EXPRESS OR IMPLIED WARRANTIES INCLUDING, BUT NOT LIMITED TO, THE IMPLIED WARRANTIES OF MERCHANTABILITY, NON-INFRINGEMENT OR FITNESS FOR A PARTICULAR PURPOSE. SOME LAWS DO NOT ALLOW THE EXCLUSION OF IMPLIED WARRANTIES. IF THESE LAWS APPLY, THEN ALL EXPRESS AND IMPLIED WARRANTIES ARE LIMITED TO THE WARRANTY PERIOD IDENTIFIED ABOVE. UNLESS STATED HEREIN, ANY STATEMENT OR REPRESENTATIONS MADE BY ANY OTHER PERSON OR FIRM ARE VOID. EXCEPT AS PROVIDED IN THIS WRITTEN WARRANTY, NEITHER EPSON AMERICA, INC. NOR ITS AFFILIATES SHALL BE LIABLE FOR ANY LOSS, INCONVENIENCE, OR DAMAGE, INCLUDING DIRECT, SPECIAL, INCIDENTAL OR CONSEQUENTIAL DAMAGES, RESULTING FROM THE USE OR INABILITY TO USE THE EPSON PRODUCT, WHETHER RESULTING FROM BREACH OF WARRANTY OR ANY OTHER LEGAL THEORY.

In Canada, warranties include both warranties and conditions.

Some jurisdictions do not allow limitations on how long an implied warranty lasts, and some jurisdictions do not allow the exclusion or limitation of incidental or consequential damages, so the above limitations and exclusions may not apply to you. This warranty gives you specific legal rights and you may have other rights which vary from jurisdiction to jurisdiction.

Epson America, Inc. • P.O. Box 93012 • Long Beach, CA 90809-3012

# Index

## A

Accessories, 49  
Advanced print settings, 13  
Advanced scanning, 22 to 24  
Aligning print head, 26 to 27  
Automatic mode, 9

## B

Banding, 15, 44  
Blank pages, 41  
Blurry image, 44, 46  
Brightness problems, 46  
Browser, 2

## C

Cable, 51  
Characters, incorrect, 45  
Checking EPSON 1000 ICS, 39  
Cleaning  
    EPSON 1000 ICS, 31  
    print head, 25 to 26  
    sheets, 16, 32  
Colors, incorrect, 45 to 47  
Control panel copy settings, 4  
Controlling printing, 10 to 11  
Copies setting, 43  
Copying  
    control panel settings, 4  
    from computer, 5 to 6  
    stand-alone, 3 to 4  
    with Smart Panel, 5 to 6  
Correcting color, 46  
Custom project types, 12 to 13

## D

Dark image, 46  
Declaration of Conformity, 55  
Default settings, 10  
Digital Camera Correction setting, 12  
Document position, 17, 47  
Documentation, 1 to 2

## E

Economy setting, 12  
Electronic manual, 2  
ENERGY STAR, 52  
Envelopes, 15  
EPSON  
    accessories, 49  
    papers, 14 to 16  
    Store, 28  
    warranty, 55 to 56  
Error messages, 37 to 38

## F

Faint images, 45  
FCC statement, 54  
File size, 47  
Filters, 12  
Flip Horizontal setting, 46  
Fluorescent lamp, 42

## G

Gamma setting, 13  
Glossy paper and film, 16  
Glossy Photo Paper, 14, 16  
Grainy printouts, 44  
Graph setting, 12

## H

Help, 49 to 50  
High Quality Ink Jet Paper, 16  
High Speed setting, 41, 44  
High-resolution images, 12, 45

## I

ICM (Image Color Matching) setting, 13  
Image quality problems, 44 to 47  
Incorrect characters, 45  
Incorrect colors, 45 to 47  
Ink cartridge  
    level of ink in, 11, 28  
    ordering, 28  
    replacing, 27 to 31  
    safety instructions, 29 to 31, 53 to 54  
Ink Jet Transparencies, 16  
Ink level, 11, 28  
Ink setting, 9  
Inverted image, 46  
Iron-On Cool Peel Transfer Paper, 16, 46

## L

Lamp, fluorescent, 42  
Layout problems, 46  
Letterhead, 7  
Low-resolution images, 12

## M

Maintaining EPSON 1000 ICS, 25 to 32  
Margin problems, 41  
Matte Paper - Heavyweight, 14, 16  
Media Type setting, 9, 16  
Mirror images, 46  
Monitoring ink level, 11, 28  
Moving EPSON 1000 ICS, 33 to 34

## N

Network printing, 40  
Noise, 39 to 41  
Nozzle Check, 26  
Nozzle check, 39

## P

Panoramic Photo Paper, 14  
Paper  
    EPSON, 14 to 16  
    feeding problems, 43  
    loading, 7, 14, 15  
    size, 11  
Parts, 35 to 36  
Photo Paper, Glossy, 16  
Photo Quality Glossy Paper or Film, 16  
Photo Quality Ink Jet Paper, 16  
Photo Stickers, 16  
PhotoEnhance, 12  
Placing documents on scanner, 17  
Premium Glossy Photo Paper, 16  
Preprinted paper, 7  
Previewing, 11  
Print dialog box, 8, 10  
Print head  
    aligning, 26 to 27  
    cleaning, 25 to 26  
Print quality problems, 44 to 46  
Printer  
    check, 26, 39  
    noise, 39 to 41  
    status, 11  
Printing  
    advanced, 13  
    controlling, 10 to 11  
    with custom project types, 12 to 13  
    with PhotoEnhance, 12  
Problems  
    installing software, 40  
    paper feeding, 43  
    print quality, 44 to 46  
    setting up EPSON 1000 ICS, 39 to 40  
Progress Meter, 11  
Project types, custom, 12 to 13

## Q

Quality/Speed setting, 9

## R

Reference Guide, 2

## S

Safety instructions, 52 to 54

Saving settings, 13

Scanning

advanced, 22 to 24

problems, 46 to 47

TWAIN, 22 to 24

Smears, 44

Software

installation problems, 40

uninstalling, 48

Special effects, 13

Special papers, 14 to 16

sRGB (standard Red Green Blue) setting, 13

Support, 49 to 50

System requirements, 51

## T

Technical support, 49 to 50

Text/Graph setting, 12

Transfer Paper, Iron-On Cool Peel, 16, 46

Transparencies, 16

Transporting EPSON 1000 ICS, 33 to 34

Troubleshooting

copying, 40 to 41

image quality, 44 to 47

paper jams, 43

printing, 40 to 41, 44 to 46

scanning, 42, 46 to 47

TWAIN instructions, 22 to 24

## U

USB, 51

Utilities

Nozzle Check, 26

Print Head Alignment, 26 to 27

## W

Warranty, 55 to 56

Watermark, 11

Windows

default settings, 10

printer status, 11

system requirements, 51



# How To Order EPSON Ink and Paper

To order EPSON ink cartridges, paper, and other printing media, contact your dealer or call EPSON at (800) 873-7766 or visit the EPSON Store at [www.epsonstore.com](http://www.epsonstore.com) (U.S. sales only). In Canada, please call (800) 873-7766 for dealer referral.



## EPSON Ink Cartridges

Black            T017  
 Color            T018

## EPSON Papers

Paper name	Size	Part number
EPSON Premium Bright White Paper	Letter (8.5 x 11 inches)	S041586
EPSON Photo Quality Ink Jet Paper	Letter (8.5 x 11 inches)	S041062
	A4 (8.3 x 11.7 inches)	S041061
	Legal (8.5 x 14 inches)	S041067
EPSON High Quality Ink Jet Paper	Letter (8.5 x 11 inches)	S041111
	A4 (8.3 x 11.7 inches)	S041117
EPSON Photo Quality Ink Jet Cards	A6 (4.1 x 5.8 inches)	S041054
EPSON Glossy Photo Paper	4 x 6 inches	S041134
	Letter (8.5 x 11 inches)	S041141/S041271/ S041272
	A4 (8.3 x 11.7 inches)	S041140
	Panoramic (8.3 x 23 inches)	S041145
EPSON Photo Stickers Kit (CD-ROM/paper)	A6 (4.1 x 5.8 inches)	S041144-KIT
EPSON Photo Stickers (refill)	A6 (4.1 x 5.8 inches)	S041144
EPSON Photo Quality Glossy Film	Letter (8.5 x 11 inches)	S041072
	A4 (8.3 x 11.7 inches)	S041071
	A6 (4.1 x 5.8 inches)	S041107
EPSON Ink Jet Transparencies	Letter (8.5 x 11 inches)	S041064
	A4 (8.3 x 11.7 inches)	S041063
EPSON Photo Quality Self Adhesive Sheets	A4 (8.3 x 11.7 inches)	S041106
EPSON Iron-On Cool Peel Transfer Paper	Letter (8.5 x 11 inches)	S041153/S041155
EPSON Photo Quality Glossy Paper	Letter (8.5 x 11 inches)	S041124
	A4 (8.3 x 11.7 inches)	S041126
EPSON Matte Paper - Heavyweight	Letter (8.5 x 11 inches)	S041257
EPSON Double-Sided Matte Paper	Letter (8.5 x 11 inches)	S041568
EPSON Premium Glossy Photo Paper	Letter (8.5 x 11 inches)	S041286
EPSON Premium Semigloss Photo Paper	Letter (8.5 x 11 inches)	S041334
EPSON Glossy Photo Greeting Card Kit	Letter (8.5 x 11 inches)	S041267

The availability of paper types varies by location.