

EPSON

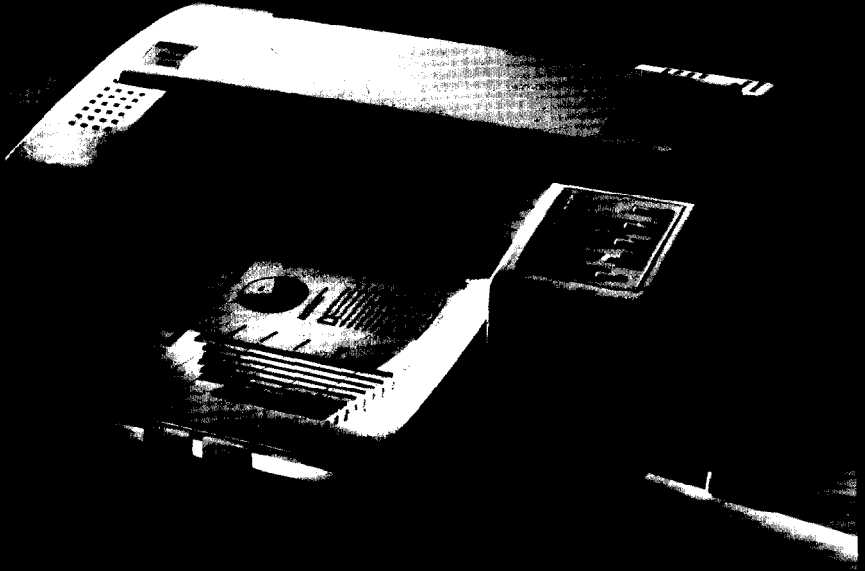

unpacking

U S E R'S

GUIDE

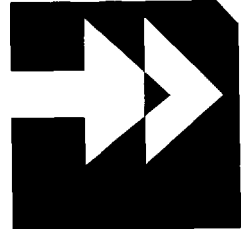

Stylus.800+

400282000DO
101-00

EPSON®

48-NOZZLE INK JET PRINTER

Stylus™ 800+

All rights reserved. No part of this publication may be reproduced, stored in a retrieval system, or transmitted in any form or by any means, mechanical, photocopying, recording, or otherwise, without the prior written permission of Seiko Epson Corporation. No patent liability is assumed with respect to the use of the information contained herein. Neither is any liability assumed for damages **resulting** from the use of the information contained herein.

Neither Seiko Epson Corporation nor its affiliates shall be liable to the purchaser of this product or third parties for damages, losses, costs, or expenses incurred by purchaser or third parties as a result of: accident, misuse, or abuse of this product or unauthorized modifications, repairs, or alterations to this product, or (excluding the US) failure to strictly comply with Seiko Epson Corporation's operating and maintenance instructions.

Seiko Epson Corporation shall not be liable against any damages or problems arising from the use of any options or any consumable products other than those designated as Original Epson Products or Epson Approved Products by Seiko Epson Corporation.

Epson and Epson **ESC/P** are registered trademarks and Epson **ESC/P 2** is a trademark of Seiko Epson Corporation.

CompuServe is a registered trademark of CompuServe Information Service.

Helvetica and Times are trademarks of Linotype AG and/or its subsidiaries.

Copyright ©1994 by Seiko Epson Corporation
Nagano, Japan

User's Guide

Tips for Printing on Single Sheets

There are a few things you should know about printing on single sheets as opposed to continuous paper. When you print on single sheets, you may notice that your printer prints the first page of your file correctly but then prints too low on the next page, or that it prints the last few lines from one page onto the next.

These differences in print position are easy to adjust; you can simply change some of the settings in your application program as described below to get the right results.

1. When you install an application program, it normally asks you what printer you are using. Make sure you choose the correct printer. See Chapter 1 for the right printer to choose.
2. Many programs include an option to set the maximum lines per page. If your program has a lines-per-page setting and you are using 8.5x11-inch paper, set the lines per page to 61; for A4, try 65.

Note:

To find the right lines-per-page setting for paper that is not 8.5x11, create a test document using your application program. Set your top and bottom margins to 0 and then create a file of numbered lines from 1 to 66. When you print your file, notice the last number printed on the first page. This is your maximum lines-per-page setting.

3. If your program doesn't have a lines-per-page setting, try decreasing the top margin or increasing the bottom margin, or both, until you get the results you want.
4. You can also try adjusting the form length setting. For an 8.5x11-inch page, try setting the form length at 10 inches (10.5 inches for A4).
5. Some programs also let you indicate whether you are using single sheets or continuous paper. Make sure you choose single sheets.

Contents

Introduction

Features	1
Energy Star Compliant	1
Where to Get Help for United States Users.....	2
For United Kingdom Users	4
Important Safety Instructions	6

Chapter 1 Setting Up Your Printer

About Your Ink Jet Printer	1-2
A few precautions	1-2
Choosing the right paper	1-3
Unpacking the Printer	1-4
Attaching the paper support	1-5
Choosing a Place for the Printer	1-6
Plugging in the Printer	1-7
Installing the Ink Cartridge	1-8
Testing the Printer	1-13
Loading paper in the paper feeder	1-13
Running the self test	1-14
Connecting the Printer to Your Computer.....	1-15
Setting Up Your Software Programs.....	1-17
Tips for Using the Paper Feeder	1-18

Chapter 2 Using Other Printer Functions

Loading Paper Manually	2-2
Paper size	2-2
Printing on single sheets	2-2
Printing on envelopes	2-4
Operating the Control Panel	2-6
Indicator lights	2-6
Buttons	2-7

Controlling the Page with Micro Feed	2-8
Adjusting the loading position	2-9
Adjusting the print position	2-10
Selecting Character Fonts	2-11
Scalable Fonts	2-12
Condensed printing	2-12
Using the Default-Settings Mode	2-13
Default settings descriptions	2-14
Changing the default settings	2-15

Chapter 3 Maintenance and Troubleshooting

Replacing the Ink Cartridge	3-2
Cleaning the Print Head	3-3
Cleaning the Printer	3-4
Transporting the Printer	3-4
Troubleshooting	3-5
Power supply	3-5
Printing	3-6
Paper handling	3-10

Appendix

Technical Specifications	A-2
Printer specifications	A-2
Interface specifications	A-7
Initialization	A-11
Command Summary	A-13
Sending printer commands	A-13
Using the command summary	A-13
General operation	A-13
Paper feeding	A-14
Page format	A-14
Print position motion	A-15
Font selection	A-15
Font enhancement	A-17
Spacing	A-17
Character handling	A-18

Bit image	A-20
Graphics	A-21
Character Tables	A-21

Glossary

Index

Printer Parts

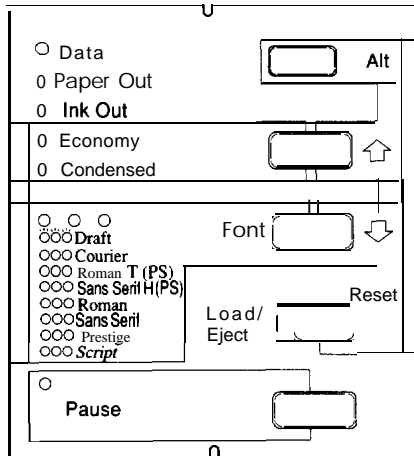
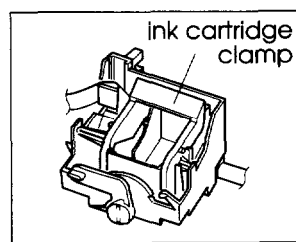
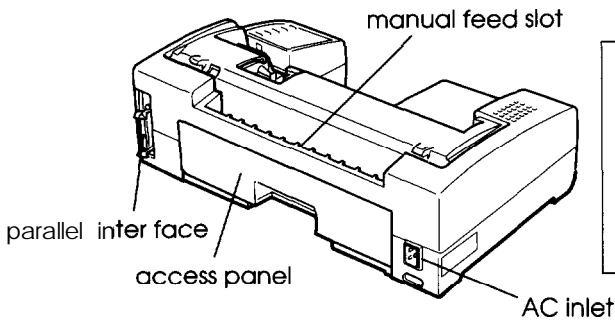
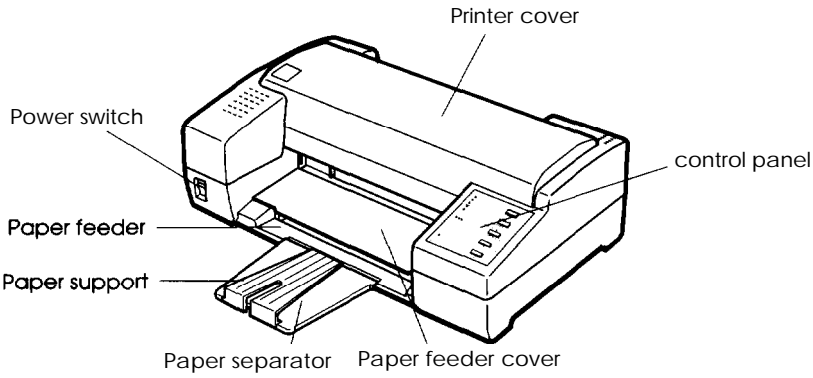

Introduction

Your new Epson® printer is a 48-nozzle ink jet printer, ideal for quiet, high-speed printing.

Features

Your printer offers the following features:

- ❑ High print quality. Epson's new ink jet technology delivers crisp 360 x 360 dots per inch (dpi) text and graphics.
- ❑ Fast printing speed. You can print up to 198 characters per second in 12-cpi letter quality (LQ) mode.
- ❑ Quiet printing. Ink jet technology helps maintain a quiet working environment.
- ❑ Compact, streamlined design. Suited to the office or home environment, its small footprint conserves your work space.
- ❑ Epson ESC/P 2™. This enhanced printer control language adds scalable fonts and improved graphics capability.
- ❑ Convenience. Drop-in ink cartridge prints up to 700 pages at 1000 characters/page.

Energy Star Compliant



Your Epson Stylus 800+ printer complies with the U.S. Environmental Protection Agency's Energy Star program, which promotes the manufacture of energy-efficient printers, computers, and monitors.

The EPA estimates that if all desktop computers, printers, and other peripheral devices met Energy Star standards, energy cost savings would exceed \$1 billion annually and carbon dioxide emissions would be reduced by 20 million tons.

The Energy Star emblem does not represent EPA endorsement of any product or service.

Where to Get Help for United States Users

Epson America provides local customer support and service through a nationwide network of authorized Epson dealers and Service Centers.

Epson also provides the following support services through the Epson ConnectionSM at (800) 922-8911:

- Assistance in locating your nearest Authorized Epson Reseller or Service Center
- Technical assistance with the installation, configuration, and operation of Epson products
- Sales of the ESC/P reference manual, which contains comprehensive information on ESC/P2
- Epson technical information library fax service
- Product literature with technical specifications on our current and new products
- Sales of ribbons, supplies, parts, documentation, and accessories for your Epson product
- Customer Relations

CompuServe® On-line Support

The fastest way to access helpful tips, specifications, drivers, application notes, and bulletins is through the Epson America Forum on CompuServe.

If you are not currently a member of CompuServe, you are eligible for a free introductory membership as an owner of an Epson product. This membership entitles you to:

- ❑ An introductory \$15 credit on CompuServe
- ❑ Your own user ID and password
- ❑ A complimentary subscription to CompuServe Magazine, CompuServe's monthly publication

To take advantage of this offer, call (800) 848-8199 in the United States and Canada and ask for representative #529. In other countries, call (614) 529-1611 or your local CompuServe access number.

If you are already a CompuServe member, simply type GO EPSON at the menu prompt to reach the Epson America Forum.

For United Kingdom Users

*Epson **product** guarantee*

Under the law, goods sold must comply with their description and must be of merchantable quality and fit for their purpose or correspond with any sample.

This guarantee does not affect the seller's legal obligation or the rights of the consumer in the "consumer transactions" under any Statute, including Sections 12 to 15 of the Sales of Goods Act, 1979.

All Epson Products, other than OEM products, are fully guaranteed against faulty operation or performance for a period of ONE YEAR from the date of purchase by the user of the product.

All claims under this guarantee **MUST** be supported by evidence of purchase, normally the bill of sale invoice, and it is the responsibility of the claimant to furnish such proof. Epson (UK) Limited do not issue or operate any form of guarantee registration card.

Claims are made by the user returning the product to the supplier from whom it was purchased or, if this is impractical, to any Epson supplier who also handles the same product. In the event of any difficulty, users are requested to contact the Service **Co-ordinator** Manager at Epson (UK) Limited.

This guarantee covers the cost of both the parts and **labour** required to correct any malfunction of the equipment, but specifically excludes wear and tear, consumables, physical damage due to incorrect use or misuse and damage or faulty operation due to unauthorized and inexpert repair.

The guarantee is restricted to the performance of the product alone, and Epson (UK) Limited does not accept responsibility for any consequential loss or damage, nor claimed or implied performance, when the product is used in any combination with other equipment or program software.

Product guarantee may be invalidated as a result of excessive or inappropriate use, use in adverse environment or conditions outside the specifications or if the product has been subjected to unapproved modifications.

The guarantee does not cover visits to the user's premises or the repair of commissioning of the product on site.

Use of options

Epson (UK) Limited shall not be liable against any damages or problems arising from the use of any options or consumable products other than those designated as Original Epson Products or Epson Approved Products by Epson (UK) Limited.

Safety information



Warning: This appliance must be earthed. Refer to rating plate for voltage and check that the appliance voltage corresponds to the supply voltage.

Important: The wires in the mains lead fitted to this appliance are coloured in accordance with the following code:

Green and yellow — Earth
Blue — Neutral
Brown — Live

As the colours of the wires in the mains lead of this appliance may not correspond with the coloured markings identifying the terminals on your plug, proceed as follows:

The green and yellow wire must be connected to the terminal in the plug which is marked with the letter E or with the earth symbol (\perp) or coloured green or green and yellow.

The blue wire must be connected to the terminal in the plug marked with the letter N or coloured black.

The brown wire must be connected to the terminal in the plug marked with the letter L or coloured red.

If damage occurs to the plug, replace the cord set or consult a qualified electrician.

Replace fuses only with a fuse of the correct size and rating.

Important Safety Instructions

1. Read all of these instructions before you set up your printer.
2. Follow all warnings and instructions marked on the printer.
3. Unplug this printer from the wall outlet before you clean it. Use a damp cloth for cleaning and do not use liquid or aerosol cleaners.
4. Do not use your printer near water or spill any liquid on it.
5. Do not place your printer on an unstable cart, stand, table, or other surface that may allow the printer to fall.

6. Do not block any slots or openings in the cabinet. These are provided for the ventilation necessary to ensure reliable operation and protection from overheating. Placing the printer on a bed, sofa, rug, or other similar surface may block the openings. Also, do not place the printer in a built-in installation, such as a bookcase, unless proper ventilation is provided.
7. Never place the printer near or over a radiator or heat register.
8. Use the type of power source indicated on the label. If you are not sure of the type of power available, consult your dealer or local power company.
9. This printer may be equipped with a plug having a third (grounding) pin, which fits only into a grounding-type outlet. This is a safety feature. If you are unable to insert the plug into the outlet, have an electrician replace your obsolete outlet. Do not defeat the purpose of the grounding-type plug.
10. Do not put your printer where the cord will be walked on.
11. If you use an extension cord, make sure that the total of the ampere ratings on the products plugged into the extension cord does not exceed the extension cord's ampere rating. Also, make sure that the total of all products plugged into the wall outlet does not exceed 15 amperes.
12. Never push objects of any kind into your printer as they may touch dangerous voltage points or short out parts that could result in a risk of fire or electric shock.

13. Except as specifically explained in the user's manual, do not attempt to repair the printer yourself. Opening or removing those covers that are marked "Do Not Remove" may expose you to dangerous voltage points or other risks. Refer all servicing in those compartments to service personnel.
14. Unplug this printer from the wall outlet and have it repaired by a qualified service person under the following conditions:
 - A. When the power cord or plug is damaged or frayed.
 - B. If liquid has been spilled into it.
 - C. If it has been exposed to rain or water.
 - D. If it does not operate normally when the operating instructions are followed. Adjust only those controls that are covered by the operating instructions since improper adjustment of other controls may result in damage and will often require extensive work by a qualified technician to restore the printer to normal operation.
 - E. If it has been dropped or the cabinet has been damaged.
 - F. If it exhibits a distinct change in performance, indicating a need for service.

Chapter 1

Setting Up Your Printer

About Your Ink Jet Printer	1-2
A few precautions	1-2
Choosing the right paper	1-3
Unpacking the Printer	1-4
Attaching the paper support	1-5
Choosing a Place for the Printer	1-6
Plugging in the Printer	1-7
Installing the Ink Cartridge	1-8
Testing the Printer	1-13
Loading paper in the paper feeder	1-14
Running the self test	1-14
Connecting the Printer to Your Computer	1-15
Setting Up Your Software Programs	1-17
Tips for Using the Paper Feeder.....	1-18

About Your Ink Jet Printer

If you're new to ink jet printers, you may wonder how they differ from dot matrix or laser printers. Two noticeable benefits of this technology are high print quality and quiet printing.

An ink jet printer produces cost-effective, quality print results. When you use the right paper, you get crisp, laser-sharp printouts usually associated with laser printers. And the ink cartridge inside your printer is easier to replace and more affordable than the toner cartridges used by lasers.

Inside the ink jet print head, tiny spray units, or jets, draw ink from the cartridge and then propel them onto the page in the form of characters or graphics. Because the print head doesn't strike the page as it prints, it is much quieter than an impact printer such as a dot-matrix.

A few precautions

Even if you are familiar with other types of printers, be sure to read through the following list of precautions to operate your ink jet printer safely and efficiently:

- cl Under normal circumstances, ink will not come out of the cartridge. If it does get on your skin, wash it off with soap and water. If it gets in your eyes, flush them immediately with water.
- ❑ Keep the ink cartridges out of the reach of children.
- ❑ Do not dismantle the ink cartridges or try to refill them.
- ❑ Once you install the ink cartridge, do not open the clamp or remove the ink cartridge except to replace it with a new one. The cartridge may become unusable otherwise.
- ❑ Install the ink cartridge immediately after you remove it from its package. Leaving the cartridge unpacked for a long time before use may result in poor print quality.

- ❑ Do not use an ink cartridge beyond its rated life expectancy. Ink cartridges are good up to the date printed on the cartridge carton.
- ❑ When moving the ink cartridge from a cold place to a warm one, let it sit for about one hour until the ink warms to the new temperature.
- ❑ Do not turn off the printer while printing or before the print head is capped. (The print head is capped when it is in the far right position.) The print head caps automatically if the printer receives no data for several seconds. You can also cap the print head by pressing the Pause button.
- ❑ Do not put your hand inside the printer or touch the cartridge during printing.
- ❑ Before transporting the printer, make sure the print head is capped, and do not remove the ink cartridge.

Choosing the right paper

One of the keys to getting great results with your ink jet printer is selecting the right paper. Paper absorbency is an especially important consideration. With paper that is too absorbent, the ink can bleed slightly, causing characters to blur. However, with paper that is not absorbent enough, the ink may take too long to dry and smear easily.

The finish and thickness of the paper are also important. Avoid paper that has a rough finish or a slick, coated finish. Also, avoid paper that is too thick or too thin. See the paper specifications in the Appendix for more information.

Most correspondence-quality paper works in your printer without problems. However, it is a good practice to test any paper or envelopes in your printer before buying large quantities.

To test a supply of paper, take a single sheet from the package and load it in the printer. Perform the self test and check the results. You should test both sides of the paper to determine which gives you the best quality printing. If the ink does not bleed or smear, the paper should be suitable for use with your printer.

Because the drying speed for the ink depends on the pattern being printed, the type of paper used, and the temperature and humidity, some smudging or streaking may occur under certain conditions. If the ink does not dry quickly enough, try removing sheets one at a time as they finish printing.

Note:

Ink jet printers are particularly sensitive to the condition of your paper. Keep unused paper in its original packaging material and store it in a cool, dry place.

Unpacking the Printer

Your printer box should include these items:

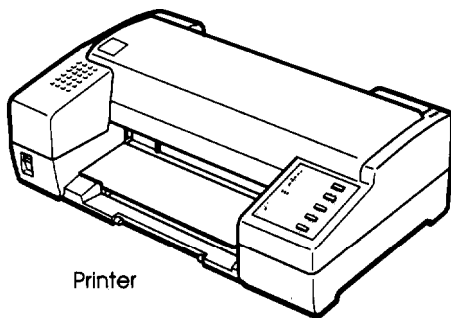

Printer

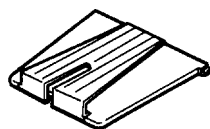

Paper support

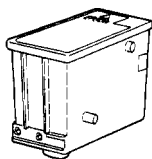

Ink cartridge



Power cord

In some locations, the power cord comes attached to the printer. The shape of the AC plug varies by country; be sure the plug included is the right shape for your location.

You must remove all packing and protective materials packed with your printer before you can set it up and turn on the power. Follow the directions on the Notice Sheet (inserted in your printer) to remove these materials.

Save all of the packaging and the protective materials in case you ever need to transport the printer.

Attaching the paper support

You should install the paper support before you begin using the printer. To install it, push the paper support notches onto the mounting posts on the printer case.

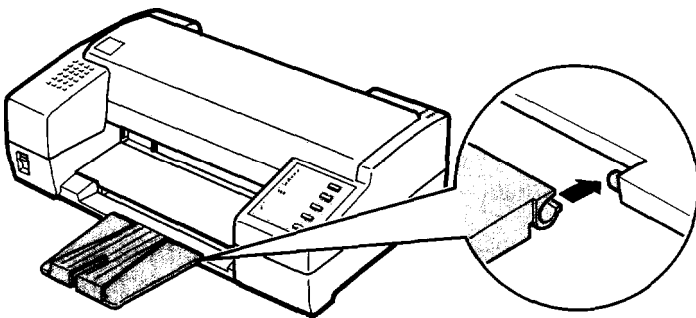

Choosing a Place for the Printer

When selecting a location for your printer, follow these guidelines:

- Place the printer on a flat, horizontal, stable surface. If the printer is tilted or at an angle, it cannot operate properly.
- Place the printer close enough to the computer for the interface cable to reach it easily.
- Leave adequate room for easy operation and maintenance.
- Avoid using or storing the printer in places subject to rapid changes in temperature and humidity. Also keep it away from direct sunlight, strong light sources, or heat generating devices.
- Avoid places subject to shocks and vibrations.
- Place the printer where you can easily unplug the power cord.
- Avoid electrical outlets controlled by wall switches or automatic timers. Also, avoid outlets on the same circuit as large motors or other appliances that can cause fluctuations in line voltage.
- Keep the entire computer system away from potential sources of electromagnetic interference, such as loudspeakers or the base units of cordless telephones.
- Use a grounded power outlet; do not use an adapter plug.

If you plan to use a printer stand, follow these guidelines:

- Use a stand that supports at least 9.6 kg (21.2 lbs).
- Never use a stand that tilts the printer. It should always be kept level.
- Place cables so they do not interfere with paper feeding; secure them to a leg of the stand if possible.

Plugging in the Printer

1. Make sure that the power switch is turned off. It is off when the 0 side of the switch is pressed down.

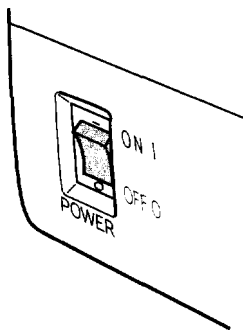

2. Check the label on the back of the printer to make sure the voltage required by the printer matches that of your electrical outlet. Also, make sure that you have the correct power cable for your power source.



Caution:

It is not possible to adjust the printer for use at another voltage. If the rated voltage and your outlet voltage do not match, contact your dealer for assistance. Do not plug in the power cord.

3. If the power cord is not attached to the printer, connect it to the AC inlet on the back of the printer.
4. Plug the power cord into a properly grounded electrical outlet.

Installing the Ink Cartridge

Each ink cartridge contains enough ink to print about 700 pages. The exact number of pages a single cartridge can print varies according to the amount of text and graphics on each page.



Caution:

The ink cartridge is a self-contained unit. Under ordinary use, ink will not leak from the cartridge. If ink does get on your hands, wash them thoroughly with soap and water. If ink gets into your eyes, flush them immediately with water.

The first time you use your new printer, you need to charge the ink delivery system with ink. You need to perform this operation only once.

To prolong the life of your ink cartridge..

- ┘ Always wait until the print head stops moving before you turn off the printer. (To stop printing quickly, press Pause and then turn off the printer.)
- ┘ Never remove the ink cartridge except to replace it **with a** new one.
- ┘ Perform the cleaning cycle only if print quality has declined.
- ┘ **Don't** move the print head by hand.
- ┘ Leave the cartridge sealed until just before you install it.

Install **the ink cartridge** as follows:

1. Make sure the printer is turned off.
2. Hold down both the **Alt** and **Pause** buttons while you turn on the printer. Release the buttons after the printer starts initializing.

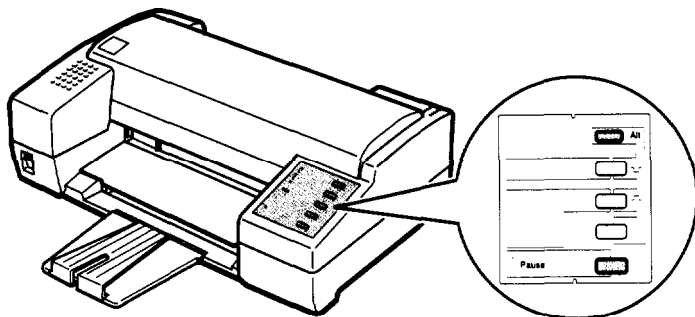

The print head moves to the ink cartridge replace position automatically.

3. Open the printer cover.

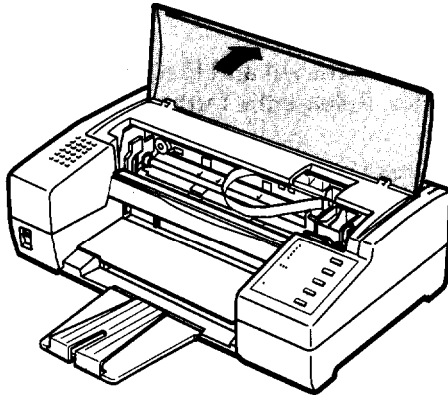

4. Pull the top of the ink cartridge clamp towards you to open it.

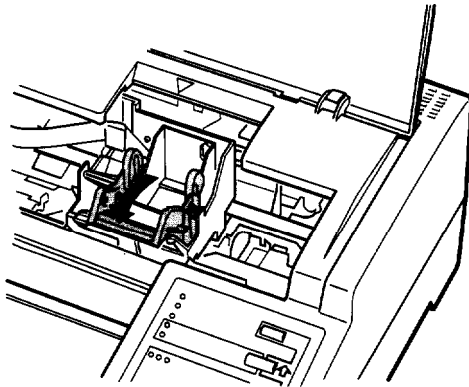

5. Open the foil package containing the ink cartridge and remove it from the protective cardboard. Make sure to remove the tape seal from the ink cartridge.

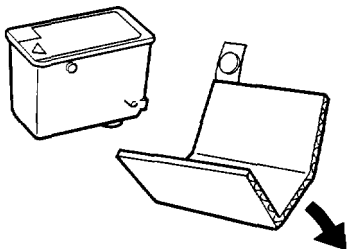

6. Lower the cartridge into the holder with the label face up and the arrow mark on the cartridge towards the arrow mark on the printer case.

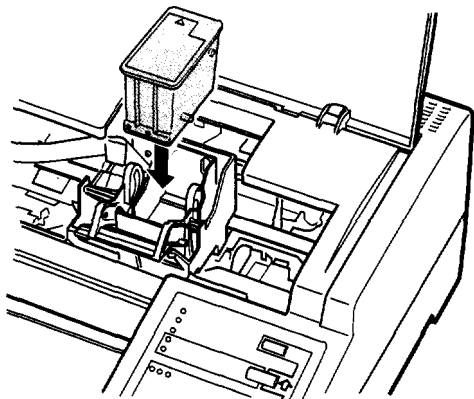

7. Push the ink cartridge clamp towards the back of the printer to secure the cartridge.

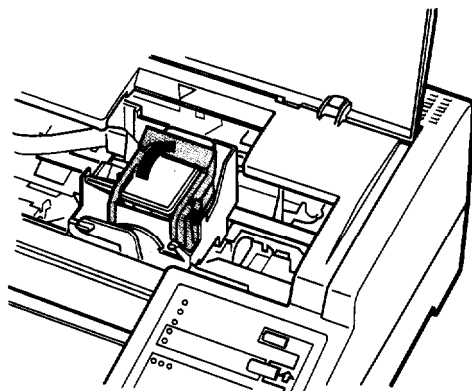

8. Press the **Alt** button again to charge the ink delivery system. It takes about one minute. The **Pause** light flashes throughout the cycle and turns off when the ink charging has finished.



Caution:

Do not turn off or reset the printer until the ink-charging cycle is complete.

9. Close the printer cover.

Testing the Printer

After you charge the ink delivery system, you can use the built-in self test to make sure the printer is working properly. You can run the self test with paper from the built-in paper feeder or by feeding a sheet manually. This section describes loading paper in the paper feeder.

Loading paper in the paper feeder

1. Open the paper feeder cover and lift the paper separator.

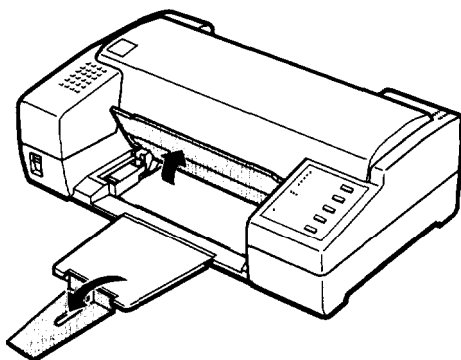

2. Fan a stack of letter-size or A4 paper; then tap it on a flat surface to even the edges.

Note:

The paper feeder holds up to 100 sheets (64 g/m² or 16 lb maximum).

3. Insert a stack of paper all the way into the paper feeder with the printable surface face-down. Align the right edge of the stack with the right edge of the paper feeder. Then move the left edge guide to match the width of your paper, as shown below.

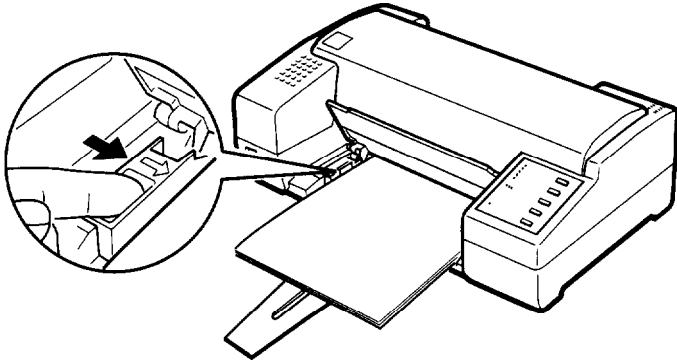

4. Close the paper feeder cover and lower the paper separator to secure the paper stack.

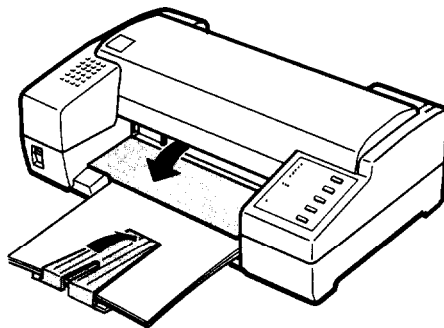

Now you are ready to run the self test. For more about printing with the paper feeder, be sure to read “Tips for Using the Paper Feeder” at the end of this chapter.

Running the self test

1. Make sure the printer is turned off.

2. While holding down the FONT button, turn on the printer. (Hold down the button until the printer starts working; it takes a few seconds.) It loads a sheet of paper automatically from the paper feeder and begins the self test.

The printer prints characters in each font, in the order the fonts appear on the control panel. Here is part of a typical self test:

Courier

```
!"#$%&'()*+,-./0123456789:;<=>?@ABCDEFGHIJKLMNOPQR  
!"#$%&'()*+,-./0123456789:;<=>?@ABCDEFGHIJKLMNOPQRS  
!"#$%&'()*+,-./0123456789:;<=>?@ABCDEFGHIJKLMNOPQRSTI  
#$%&'()*+,-./0123456789:;<=>?@ABCDEFGHIJKLMNOPQRSTU  
$%&'()*+,-./0123456789:;<=>?@ABCDEFGHIJKLMNOPQRSTUV  
%&'()*+,-./0123456789:;<=>?@ABCDEFGHIJKLMNOPQRSTUVW  
&'()*+,-./0123456789:;<=>?@ABCDEFGHIJKLMNOPQRSTUVWX  
Roman T  
'()*+,-./0123456789:;<=>?@ABCDEFGHIJKLMNOPQRSTUVWXYZ[^\`_`abcdefghijklmnopqrstuvwxyz  
()*+,-./0123456789:;<=>?@ABCDEFGHIJKLMNOPQRSTUVWXYZ[^\`_`abcdefghijklmnopqrstuvwxyz  
)*+,-./0123456789:;<=>?@ABCDEFGHIJKLMNOPQRSTUVWXYZ[^\`_`abcdefghijklmnopqrstuvwxyz
```

3. The self test continues until the paper in the paper feeder runs out or you press the Pause button. To stop the test, press the Pause button. To resume the test, press the Pause button again.
4. To end the self test, press the Pause button to stop printing and then press the Load/Eject button to eject the paper.
5. Turn off the printer.

Connecting the Printer to Your Computer

If the self test prints correctly, you are ready to connect your printer to the computer. You need a shielded twisted-pair parallel cable to connect your computer to the printer's built-in parallel interface.

Follow these steps:

1. Make sure both the printer and computer are turned off.
2. Plug the cable connector securely into the printer's interface connector.
3. Squeeze the wire clips together until they lock in place on both sides. If your cable has a ground wire, connect it to the ground connector above the interface connector.

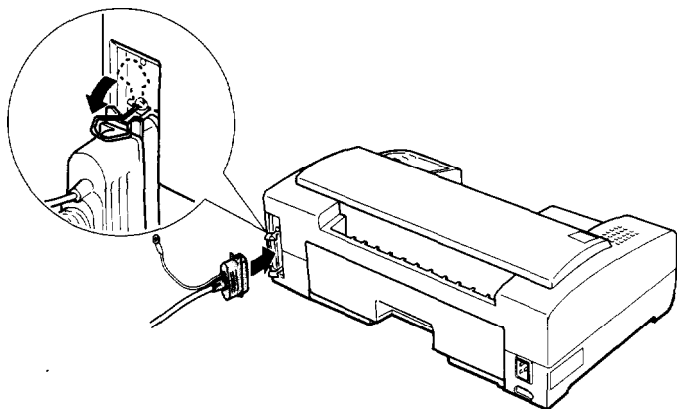

4. Plug the other end of the cable into the computer's parallel interface. If there is a ground wire at the computer end of the cable, connect it to the ground connector at the back of the computer.

Setting Up Your Software Programs

Most application programs let you specify the type of printer you use so that the program can take full advantage of the printer's features. Many of these programs provide an installation or setup menu that presents a list of printers.

To take full advantage of your printer's features, including ESC/P 2, choose one of the first six printers on the list below. If none of these is listed, contact your software manufacturer for an update that includes one of these. Until you receive an update, choose another printer as close to the top of the list as possible.

Stylus 800+	ESC/P 2	SQ-850/2550	ESC/P
Stylus 800		LQ-850+/1050+	
SQ-870/1170		LQ-550/1010	
LQ-870/1170		LQ-500	
LQ-570/1070		LQ-2550	
LQ-100		LQ-800/1000	
		LQ-1500	

If none of these printers is listed among your program's options, select the first one available from the following: LQ, EX, FX, LX, RX, MX, Epson printer, Standard printer, and Draft printer.

After you select the most appropriate printer as described above, you may want to create and print a sample file with the fonts and formats that you use most often. Printing the sample file shows you how the printer works with your application program.

If the printing results are not what you expect, see "Troubleshooting" in Chapter 3 or consult your computer or software manual.

Tips for Using the Paper Feeder

Following the tips below will give you the best performance when printing with the paper feeder.

- ❑ Load paper into the paper feeder before you turn on the printer and send data. When the printer receives data from the computer, it loads a single sheet automatically and begins to print.
- ❑ If the printer runs out of paper during a print job, reload the paper feeder and then press the Load/Eject button to continue printing.
- ❑ Press the Load/Eject button if you need to eject a sheet of loaded paper.
- ❑ You can switch to manual loading to feed single sheets or envelopes without removing the paper supply from the paper feeder. For instructions, see “Loading Paper Manually” in Chapter 2.
- ❑ You can adjust the loading and print positions with the printer’s micro feed feature. See “Controlling the Page with Micro Feed” in Chapter 2. Because most application programs take care of the top and bottom margins, you should usually adjust the margins by using your programs, taking the printer’s default loading position into account.
- ❑ The default page length for paper loaded from the paper feeder is 61 lines (letter-size paper) and 65 lines (A4-size paper). You can change it using your application program or printer commands, if necessary. See the Appendix for more about printer commands.
- ❑ If the ink does not dry fast enough, try removing sheets one at a time as they finish printing.

Chapter 2

Using Other Printer Functions

Loading Paper Manually	2-2
Paper sizes	2-2
Printing on single sheets	2-2
Printing on envelopes	2-4
Operating the Control Panel	2-6
Indicator lights	2-6
Buttons	2-7
Controlling the Page with Micro Feed	2-8
Adjusting the loading position	2-9
Adjusting the print position	2-10
Selecting Character Fonts	2-11
Scalable Fonts	2-12
Condensed printing	2-12
Using the Default-Settings Mode	2-13
Default settings descriptions	2-14
Changing the default settings	2-15

Loading Paper Manually

You can load single sheets of paper or envelopes from the manual feed slot without removing the paper supply from the paper feeder.

Note:

The instructions in this section describe loading paper by hand in the manual feed slot. If you want instructions for using the paper feeder, see page 1-1 8 in Chapter 1.

Paper sizes

You can use the manual feed slot to load single sheets of paper from 182 mm (7.1 inches) to 216 mm (8.5 inches) wide and from 257 mm (10.1 inches) to 297 mm (11.7 inches) long.

You can also load the following envelope sizes from the manual feed slot:

- Envelope No. 6, 166 mm (6.5 inches) wide x 92 mm (3.6 inches)
- Envelope No. 10, 240 mm (9.5 inches) wide x 104 mm (4.1 inches)

Printing on single sheets

Follow these steps to load a single sheet in the manual feed slot:

1. Turn on the printer.

2. Insert a single sheet of paper into the slot until it meets resistance, aligning the right edge of the paper with the arrow mark on the printer. The printer automatically loads the sheet.

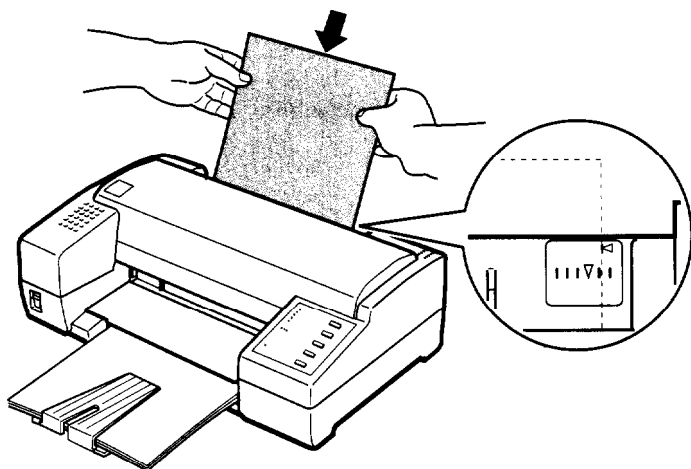

Note:

If the sheet does not load straight, press the Load/Eject button to eject it. Then try loading it again.

3. Send data from the computer to the printer. When the printer receives the data, it begins printing.

When the printer finishes printing, it ejects the sheet automatically. If the sheet does not come all the way out, press the Load/Eject button.

4. You can print as many sheets as you like from the manual slot. When you want to switch to the paper feeder, press the Load/Eject button and do not insert a sheet into the manual slot. The printer then loads a sheet of paper from the paper feeder.

Note:

If the ink does not dry fast enough, try removing sheets one at a time as they finish printing.

Printing on envelopes

You can also use the manual feed slot to print on individual envelopes.

1. Turn on the printer and open the printer cover.
2. Turn the paper-thickness lever clockwise as far as it will go.

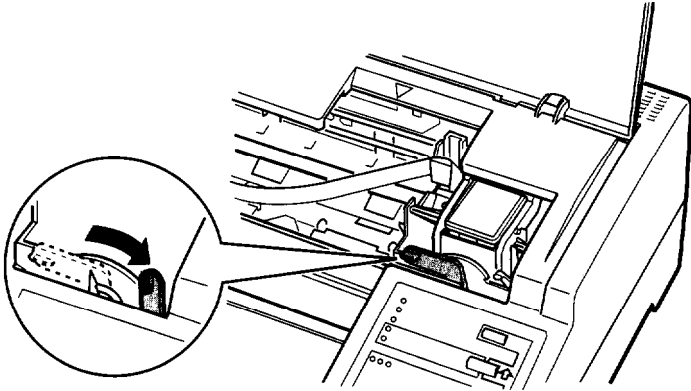

3. Close the printer cover.

4. Insert an envelope into the manual feed slot with the wide end at the top entering the printer first, and the printable side face-up, until it meets resistance. The printer loads the envelope to the print position automatically.

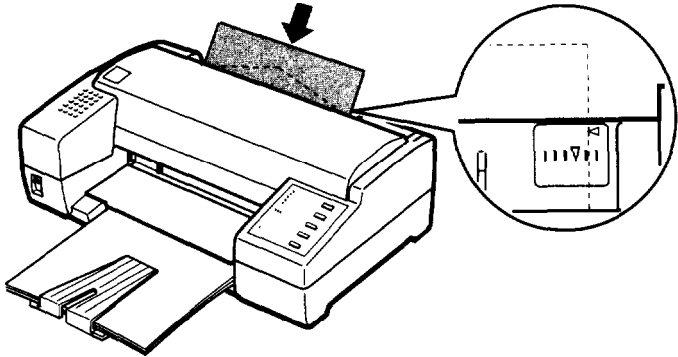

5. Send data from your computer. The printer ejects the envelope automatically when it is finished printing.

Note:

- Make sure your application program keeps the printing entirely within the printable area of the envelope. For a description of the printable area, see the Appendix.*
- Use envelopes only under normal operating conditions.*
- If** the ink is not drying fast enough, try removing envelopes one at a time as they finish printing.*

6. To switch back to the paper feeder, turn the paper-thickness lever counterclockwise as far as it will go. Then press the Load/Eject button to load from the paper feeder.

Operating the Control Panel

The printer control panel gives you easy control over most common printer operations. It consists of indicator lights and buttons.

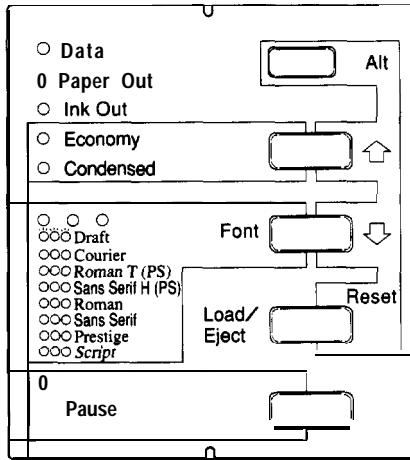

Indicator lights

Pause

On when printing is paused

Font

Indicate the current font setting. These three lights go on and off when you press the FONT button. The font menu on the control panel helps you determine which font is selected. For instructions on selecting fonts, see page 2-11.

Condensed

On when the condensed printing mode is selected. When this mode is selected, the printer prints a condensed version of selected fonts. See page 2-12 for more information.

Economy

On when the economy printing mode is selected. When this mode is selected, the printer uses fewer dots per character. The print speed is the same in both economy and LQ mode, but the economy mode uses less ink. This mode is ideal for rough drafts and editing work.

Ink Out

On when the ink cartridge runs out of ink. Rapid flashing indicates the ink is low. For instructions on replacing the ink cartridge, see page 3-2.

Paper Out

On when the printer runs out of paper. Rapid flashing indicates a paper jam.

Data

On when data remains in the printer's memory.

Buttons

Pause

Press this button to stop printing temporarily. Press it again to resume printing.

load/Eject

Press the Load/Eject button to load or eject a sheet of paper. If you have been printing from the manual feed slot, pressing this button switches paper loading back to the paper feeder.

Font

Press this button to cycle through the font choices on the font menu. The Font lights indicate the current selection.

Economy/Condensed

Press the Economy/Condensed button to select economy printing or condensed mode. Press it again to turn your selection off. The indicator light goes on or off next to the mode you select.

Alt

Hold down this button for several seconds to move the print head to the ink cartridge replace position when the printer is paused.

The Alt button also alters the functions of the other buttons. Hold down the Alt button and press another button to change the functions as follows:

PRINT HEAD CLENGING (Alt + Pause)

Starts print head cleaning cycle. See “Cleaning the Print Head” on page 3-3 for details.

Reset (Alt + Load/Eject)

Clears the printer’s buffer and initializes the printer settings to their factory settings. See “Initialization” on page A-11 for details.

MICRO FEED:

(Alt + Font)

Feeds paper forward in 1 /180-inch increments.

(Alt + Economy/Condensed)

Feeds paper backward in 1/180-inch increments. See “Controlling the Page with Micro Feed,” below for details.

Controlling the Page with Micro Feed

You can use the printer’s micro-feed feature to adjust the paper loading position or to adjust the current print position during a print job.

When you adjust the loading position for single-sheet paper, the printer remembers the new position only until you turn off the power. The loading position returns to the factory setting when the power is turned on again.

Adjusting the loading position

The loading position is the position of the paper when **the** printer loads it from the paper feeder or the manual feed slot. If printing is too high or low on the page, you can change the loading position with the micro-feed feature as follows:

1. Make sure the printer is turned on.
2. Load a sheet of paper from the paper feeder by pressing the Load/Eject button, or from the manual feed slot by inserting it into the slot.
3. Open the paper feeder cover.
4. As soon as the paper is loaded, hold down the **Alt** button and press the **Economy/Condensed** button to move the loading position up 1/180 inch, or the **Font** button to move the loading position down 1 / 180 inch. Continue pressing the appropriate buttons until you reach the position you want.

The pointer on the print head indicates the base line of printed characters. (You may have to experiment a few times to get **the** results you **want**.)

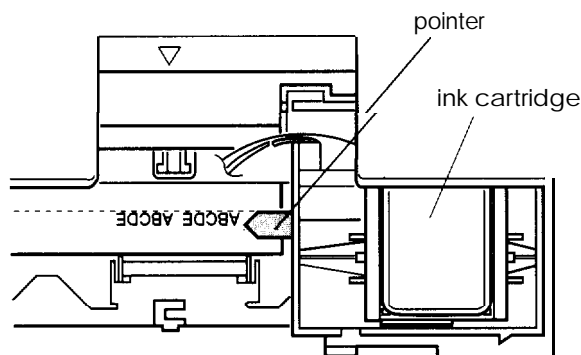

5. Close the paper feeder cover.
6. Send data from the computer to start printing.

Note:

- ❑ *The printer has a minimum and maximum loading position. If you try to move the loading position beyond these limits, the printer beeps and the paper stops moving.*
- ❑ *When the paper reaches the factory-set loading position, the printer beeps. Use the factory setting as a reference point when adjusting the loading position.*

Adjusting the print position

The print position is the position on the page where the print head actually prints during a print job. If you want to change the current print position, you can use the micro-feed feature as follows:

1. Press the Pause button to stop printing; the Pause light comes on.
2. Hold down the Alt button and press the Economy/Condensed (up) or Font (down) button to adjust the print position on the page.
3. Press the Pause button again to resume printing. (You may have to experiment a few times to get the results you want.)

Note:

The printer has a limit — 8.0 mm (0.31 inch) — to the amount you can move the print position backwards using micro feed. Feeding stops when you reach this limit.

Selecting *Character Fonts*

Your printer has eight built-in character fonts including two new Epson fonts: the Epson Roman T and Epson Sans Serif H. (Roman T is similar to the Times™ font; Sans Serif H is similar to Helvetica™.)

Press the FONT button to select from the eight fonts listed on the control panel. The three Font lights come on (○), flash (◐), or go off (●) to indicate the active font.

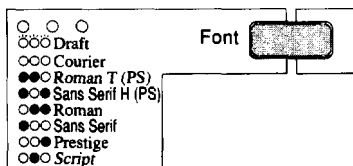

The table below lists the available fonts and shows how the Font lights appear for each selection.

Font lights	Fonts	Sample
◐ ◐ ◐	Epson Draft	ABCDEFGHIj k l m 0 1 2 3 4 5 6 7 8 9
○ ○ ○	Epson Courier	ABCDEFGHIj k l m 0 1 2 3 4 5 6 7 8 9
● ● ○	Epson Roman T	ABCDEFGHIj k l m 0 1 2 3 4 5 6 7 8 9
● ○ ●	Epson Sans Serif H	ABCDEFGHIj k l m 0 1 2 3 4 5 6 7 8 9
○ ● ●	Epson Roman	ABCDEFGHIj k l m 0 1 2 3 4 5 6 7 8 9
● ○ ○	Epson Sans Serif	ABCDEFGHIj k l m 0 1 2 3 4 5 6 7 8 9
○ ○ ●	Epson Prestige	ABCDEFGHIj k l m 0 1 2 3 4 5 6 7 8 9
○ ● ○	Epson Script	ABCDEFGHIj k l m 0 1 2 3 4 5 6 7 8 9

○ on ● off ◐ flashing

Note:

- Roman T and Sans Serif H fonts are available in proportional spacing only.
- Font selections you make with your application program usually override these control panel selections. For best results, use your application program to select fonts.

Scalable Fonts

The size of the Roman, Sans Serif, Roman T, and Sans Serif H fonts can be selected from 8 to 32 points in 2-point increments by using your application program or by sending an ESC/P 2 command. See the documentation that came with your application program for information on selecting the size of scalable fonts. See the Appendix of this manual for a list of ESC/P 2 commands.

Roman			
Epson	Epson	Epson	Epson
Roman T			
Epson	Epson	Epson	Epson
Sans Serif			
Epson	Epson	Epson	Epson
Sans Serif H			
Epson	Epson	Epson	Epson

Condensed printing

Condensed printing reduces the size of characters to approximately 60 percent of their normal width, allowing more characters to fit on a line. This is useful for spreadsheets and other applications where you need to print the maximum amount of information on a page.

You can condense the current font by pressing the Economy/Condensed button. (Epson Roman T and Epson Sans Serif H cannot be condensed.) You can condense printing that is 10 cpi, 12 cpi, and proportionally spaced. You cannot condense 15-cpi printing.

Note:

If your application program controls character fonts and can select the condensed mode, you should select condensed mode through the program rather than with the control panel. Program or command settings usually override control panel settings.

Using the Default-Settings Mode

Your printer comes with a series of internal settings that control a variety of printer functions, such as print direction and auto line feed. Because these settings take effect each time you turn on the printer, they are called default settings.

The factory default settings are designed to meet the needs of most users, so you may not need to change them. The table below lists all the features you can select in the default-settings mode.

For a detailed description of each setting, see “Default Settings Descriptions.” To change a setting, see “Changing the default settings” on page 2-15.

Setting	Options
Character table	Availability varies by country. See pages 2-16 and A-22 for details.
Auto print direction	On, Off
Network interface mode	On, Off
Mixed text/graphics mode	On, Off
Auto line feed	On, Off

Note:

Most application programs control the character table and auto line feed. If your application program controls these features, you may never need to set them with the control panel.

Default settings descriptions

Character table

Character tables contain the characters and symbols used by different languages. The printer prints text with the selected character table. When you select this feature, the font lights on the control panel go on or off to indicate the current selection.

Auto print direction

The printer ordinarily prints text bidirectionally for speed and prints graphics characters unidirectionally for precise vertical alignment.

When auto print direction is set to on, the printer switches automatically between bidirectional (for text data) and unidirectional motion (for graphics data). When this feature is set to off, the print head motion is controlled by your software.

Network interface mode

If your printer is connected to a single computer, leave this feature off. If you want to use the printer in a network environment and share it among multiple computers, set this feature to on.

When this feature is set to on, data may be present in the printer's buffer even though the printer is not continuously printing. Always make sure the data light is off before turning off the printer.

Mixed text/graphics mode

This feature is for software that has problems printing scalable font text combined with graphics. Leave the mixed text/graphics mode set to off if you do not notice any problems in your printout.

Auto line feed

When the auto line feed feature is on, each carriage return (CR) code is accompanied by a line feed (LF) code. If your printed text is unexpectedly double-spaced, set this feature to off. If text lines print on top of each other, set it to on.

Changing the default settings

To change the printer's default settings, you press the control panel buttons; the control panel lights show your selections.

Follow the steps below to make your changes:

1. Make sure the printer is **turned off** and paper is loaded in the paper feeder.
2. Hold down the Economy/Condensed button and **turn on** the printer to enter the default-settings mode. (Hold down the button until the printer starts working; it takes a few seconds.)

The printer loads a sheet of paper and prints a brief summary and instructions. It instructs you to select the language that you want messages printed in (English, French, German, Italian, or Spanish).

3. Press the **Font** button until the **Font** lights indicate the language of your choice; then press the **Alt** button to make your selection.

Language	Font light
English	● ● ○
French	● ○ ●
German	○ ● ●
Italian	● ○ ○
Spanish	○ ○ ●

○ on ● □ ×

After you press the **Alt** button, the printer prints the current default settings and the next instruction in the language you selected. Wait until printing is finished, then go to the next step.

- To move to the feature you want to change, press the **Alt** button until the **Data**, **Paper Out**, and **Ink Out** lights indicate the appropriate selection.

Default-setting menu	Data light	Paper Out light	Ink Out light
Character table	●	●	○
Auto print direction	●	●	⦿
Network interface mode	●	○	●
Mixed text/graphics mode	●	○	○
Auto line feed	●	○	⦿

○ on ● off ⦿ flashing

For example, if you want to change the character table setting, press the **Alt** button until the **Data** and **Paper Out** lights are off and the **Ink Out** light is on.

- Next, press the **Font** button to change the setting.

As you move from setting to setting, the **Font** lights turn on (○), off (●), and flash (⦿) to show your selection, as indicated in the printed sample. The next page shows a typical sample printout.

Character table ITALIC U.S.A
 Auto print direction ON
 Network I/F mode OFF
 Mixed text/graphics mode OFF
 Auto line feed OFF

--- Using the default setting mode ---

- (Step1) Select menu(a)-(e) by pressing the ALT switch.
 DATA, PAPER OUT, and INK OUT LEDs show menu selected at that time.
 (Step2) Change setting value by pressing the FONT switch.
 FONT LEDs show setting value selected at that time.
 (Step3) Repeat (Step1) and (Step2) according to following guide printing.
 (Step4) Turn off the printer to finish setting.

--- LEDs means follows ---

	o DATA	o LED On
menu	o PAPER OUT	o LED Blink
c	o INK OUT	o LED Off
setting value	ooo FONT	

MENU (CHANGE BY ALT)	SETTING VALUE (CHANGE By FONT)	MENU (CHANGE BY ALT)	SETTING VALUE (CHANGE BY FONT)
(a)Character table • • o	ITALIC	(b)Auto print direction • • o	On ●●
	U.S.A ●●		Off ●●o
	FRANCE • *a ●●o		
	GERMANY ●●o		
	U.K. ●●o		
	DENMARK1 ●●o	(c)Network I/F mode • o •	Off ●●
	SWEDEN ●●o		On ●●o
	ITALY ●●o		
	SPAIN1 ●●o		
	PC437 ●●o		
	PC850 ●●o	(d)Mixed text / graphics mode • o o	Off ●●
	PC860 ●●o		On ●●o
	PC863 ●●o		
	PC865 ●●o		
	PC861 ●●o		
	BRASC11 ●●o	(e)Auto linefeed • o o	Off ●●
	Abicomp ●●o		On ●●o

6. Repeat steps 4 and 5 to make all of your changes.
7. To exit the default-settings mode, turn the printer off.

Note:

- ❑ *You may exit the default-settings mode any time by turning off the printer. Any changes you have made remain in effect until you change them again.*
- ❑ *If you want to check the new default settings, enter the default-settings mode again and **print** the current settings. After you check them, turn the printer off to exit without making changes.*

Chapter 3

Maintenance and Troubleshooting

Replacing the Ink Cartridge	3-2
Cleaning the Print Head	3-3
Cleaning the Printer	3-4
Transporting the Printer	3-4
Troubleshooting	3-5
Power supply	3-5
Printing	3-6
Paper handling	3-10

Replacing the Ink Cartridge

When the Ink Out light on the control panel flashes, the ink in the ink cartridge is low. The printer will continue printing **until** the cartridge is completely empty. When it is out of ink, the printer stops and the Ink Out light stays on. Printing will not resume until you insert a new cartridge.

It's a good idea to keep a spare ink cartridge on hand. Use Epson ink cartridge SO20025 to ensure proper operation and preserve the life of the print head. Other brands of ink may clog the print head or damage it.

Follow these steps to remove the empty cartridge:

1. Make sure the printer stops printing and both the Ink Out and Pause lights stay on. Then open the printer cover.
2. Hold down the **Alt** button for several seconds and release the button when the print head moves to the ink cartridge replace position.
3. Pull the ink cartridge clamp toward you to release the cartridge. (The clamp pushes the ink cartridge up so it is easy to grasp.)

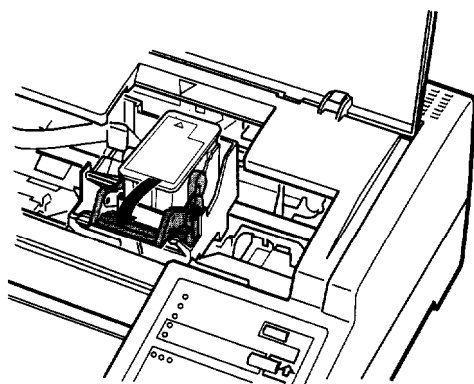

4. Lift the cartridge out of the printer and dispose of it properly. Do not take the used cartridge apart or try to refill it.



Caution:

If ink does get on your hands, wash them thoroughly with soap and water. If ink gets into your eyes, flush them immediately with water.

5. Turn to page 1-11 and follow the steps there to install the new cartridge.

Note:

When you replace the cartridge, the printer will not recharge the ink delivery system again. However, the print head may start moving as the printer performs normal maintenance procedures. This can take up to 40 seconds to complete.

Cleaning the Print Head

If print quality diminishes, use the printer's built-in print-head cleaning cycle to ensure that the nozzles are delivering ink properly. To avoid wasting ink, clean the print head only if print quality declines.

Follow these steps:

1. Make sure the printer is **turned** on and the Pause light is on. If the Pause light is not on, press the Pause button to pause the printer.
2. Hold down the **Alt** button and press the Pause button for two seconds.

The cleaning cycle takes about **40** seconds. The Pause light flashes throughout the cycle and then stays on when the cleaning cycle is finished.

3. Press the Pause button to resume printing.

Cleaning the Printer

To keep your printer operating at its best, you should clean it thoroughly several times a year.

1. Make sure the printer is **turned off**.
2. Remove any paper from the paper feeder.
3. Use a soft brush to carefully brush away all dust and dirt.
4. If the outer case or the inside of the paper feeder is dirty, **clean** it with a soft, clean cloth dampened with mild detergent. Keep the printer cover closed to prevent water from getting inside the printer.
5. If the inside of the printer accidentally gets soiled with ink, wipe it off with a damp cloth.



Caution:

- Never use alcohols or thinners to clean the printer; these chemicals can damage the components as well as the case.*
- Be careful not to get water on the printer mechanism or electronic components.*
- Do not use a hard or abrasive brush.*
- Do not spray the inside of the printer with lubricants; unsuitable oils can damage the mechanism. Contact your dealer or a qualified service person if lubrication is needed.*

Transporting the Printer

If you need to transport your printer some distance, carefully repack it using the original box and packing materials as follows:

1. Open the printer cover and make sure **that** the print head is capped in the far right position. If the print head is not capped, **turn on the** printer to cap it. Then, **turn off** the printer.

Note:

Do not remove the ink cartridge when transporting.

2. Unplug the power cord from the electrical outlet; then disconnect the interface cable from the printer.
3. Remove the paper from the paper feeder.
4. Attach the protective material to the printer.
5. Repack the printer and power cord and place them in the original box.
6. Keep the printer flat in the box during transport.
7. If the print quality is poor after transport, clean the print head. See “Cleaning the Print Head.”

Troubleshooting

Most problems you may encounter while operating your printer have simple solutions. Find your problem in this section and follow the recommended steps. If you cannot solve your problem, contact your dealer or a qualified service person for assistance.

Power supply

The printer does not work or control panel lights are off.

Check that the power cord is properly plugged into the electrical outlet.

Check that the side of the power switch with the vertical bar (I) is pressed down to turn on the printer.

If the electrical outlet is controlled by an outside switch or automatic timer, use a different outlet.

Plug another electrical device into the outlet to determine whether it is working.

The lights come on briefly but then go off and stay off.

Check that the printer's voltage rating matches the voltage of your electrical outlet. If the voltages do not match, unplug the printer and contact your dealer immediately. Do not reconnect the power cord to an electrical outlet.

Printing

All lights on the control panel are on but nothing prints.

Contact your dealer.

Printing stops and the printer beeps five times.

A carriage error occurred. Turn off the printer. After a few seconds turn it on again.

The Ink Out light flashes.

The ink cartridge is almost out of ink. Get ready to replace the ink cartridge.

The Ink Out light is on and the printer beeps three times; the printer does not print.

The ink cartridge may be empty, or not installed at all. Replace the ink cartridge with a new one.

Printing stops and the Pause light is on.

Printing was temporarily suspended. Press the Pause button to continue.

The Pause light is off but nothing prints.

The interface cable may not be plugged in securely. Check both ends of the cable between the printer and the computer. Make sure your interface cable meets both the printer and computer specifications.

Make sure that your software is properly set up for your printer.

Printed output is not as expected.

If the printer does not print correctly, try the self test described in Chapter 1. If the self test works properly, the printer is all right, and the problem probably lies in the computer, the application program, or the interface cable. If the self test does not work, contact your dealer or a qualified service person.

Check the printer settings within your software program.

Use the hex dump mode to pinpoint communication problems between the printer and your application program. To enter the hex dump mode, hold down the Load/Eject and Font buttons and turn on the printer. (Hold down the buttons until the printer starts working; it takes a few seconds.) Then send data from the computer. The printer prints the exact codes it receives from the computer in hexadecimal format. You can analyze this information to isolate problems.

The printer sounds like it is printing, but nothing prints.

The print head nozzles may be clogged. Hold down the Alt button and press the Pause button for two seconds to clean the print head. See “Cleaning the Print Head” earlier in this chapter.

Dots are missing in printed characters or graphics.

The print head nozzles may be clogged. Hold down the Alt button and press the Pause button for two seconds to clean the print head. See “Cleaning the Print Head” earlier in this chapter.

Set the Mixed text/graphics mode to on in the default-settings mode. See “Using the Default-Settings Mode” in Chapter 2.

Set the Network interface mode to on in the default-settings mode. See “Using the Default-Settings Mode” in Chapter 2.

The printed image is light or faint.

The print head nozzles may be clogged. Hold down the Alt button and press the Pause button for two seconds to clean the print head. See “Cleaning the Print Head” earlier in this chapter.

The paper-thickness lever may not be set correctly. The raised position for envelopes may cause faint printouts if used for plain paper. For details on the paper-thickness lever, see “Loading Paper Manually” in Chapter 2.

Your paper may be moist or damp. Ink jet printers are sensitive to moisture absorbed by the paper. Do not store your paper in a damp or humid environment.

You may have selected the economy printing mode. To exit this mode, press the Economy/Condensed button until the Economy light goes off.

The printed image is blurred.

You may not be using the correct type of paper. Although most types of business-correspondence-quality paper work well with your printer, you should always test the paper you want to use before buying it in large quantities. See Chapter 1 for tips on choosing the right paper.

You may not be printing on the correct side of the paper. Test both sides to determine which side gives you **the** best print quality.

Your paper may be moist or damp. Do not store your paper in a damp or humid environment.

The tpestyles or characters set with your software do not print.

Check that the program is correctly configured for your printer.

The font selected on the control panel does not print.

Your software settings may be overriding the control panel setting. Check the font settings in your software.

The wrong characters are printed.

The wrong character table is selected. Change the character table as described in “Using the Default-Settings Mode” in Chapter 2.

Printing starts too high or too low on the page.

Adjust the top margin using your application program or use the printer’s micro feed feature to make minor adjustments to the loading position. See “Controlling the Page with Micro Feed” in Chapter 2.

All the text prints on the same line.

Set auto line feed to on in the default-settings mode so that the printer automatically adds a line-feed code to each carriage return. See “Using **the** Default-Settings Mode” in Chapter 2.

The text prints an extra blank line between each text line.

Set auto line feed to off in the default-settings mode so that two line-feed signals are not sent. See “Using the Default-Settings Mode” in Chapter 2.

Line spacing is incorrect. Adjust the line-space setting with your software.

Printed page length is not as expected.

The page length setting may not match the length of the paper loaded in the printer. Change the page length setting within your software to match to the paper you are using.

Paper handling

The printer does not print; the Paper Out light is on and the printer beeps three times.

No paper is loaded in the printer. Load paper in the paper feeder or from the manual feed slot.

Single sheets do not feed properly from the paper feeder.

Too many sheets are loaded in the paper feeder. Remove the paper from the paper feeder and reload up to 100 sheets.

The paper is too thick or too thin to be fed. Make sure that the paper you are using meets the specifications. Some paper types require manual feeding. See “Technical Specifications” in the Appendix.

The printer loads more than one sheet at a time.

The paper is too thin. Make sure that the paper you are using meets the specifications. Some paper types require manual feeding. See “Technical Specifications” in the Appendix.

The ejected paper is wrinkled.

The paper is too thin or is damp. Make sure that the paper you are using meets the specifications. See “Technical Specifications” in the Appendix. Do not store your paper in a damp or humid environment.

The paper does not fully eject.

Use the Load/Eject button to eject the page.

The paper may be too long to be loaded from the manual feed slot. Use paper that is within the specified size. See “Technical Specifications” in the Appendix.

Paper is loaded crookedly from the manual feed slot.

Use the Load/Eject button to eject the page. Then insert a new sheet straight into the manual feed slot.

The paper is jammed inside the printer.

To clear a paper jam follow the steps below.

1. Open the printer cover and the paper feeder cover.
2. Pull the access panel away from the rear of the printer, as shown below.

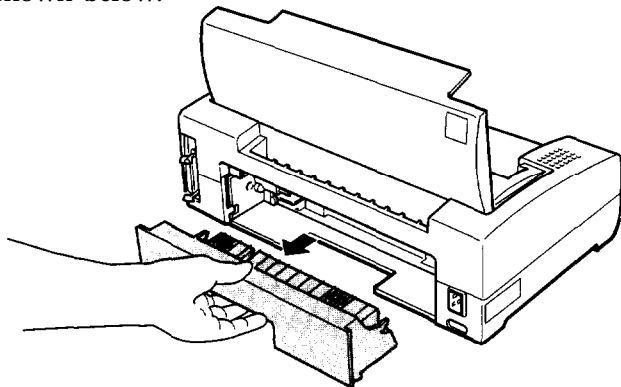

3. Pull the paper out gently. If the paper tears, make sure you remove any remaining pieces.

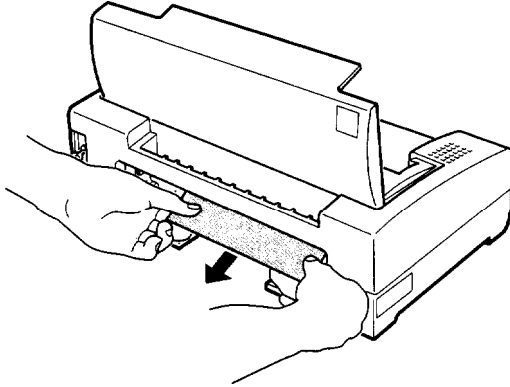

4. If the paper is caught in the paper ejection area, gently pull it out of the printer.
5. Push the access panel back onto the rear of the printer and close the printer cover and the paper feeder cover.

Preventing paper feed and paper jam problems

If you have frequent paper feed or paper jam problems, refer to this checklist of corrective measures:

- Use a higher-quality paper, one that is not too thin or rough. Some types of paper require manual feeding. See Chapter 2.
- Fan the stack of paper and then tap it on an edge to align it before you load it.
- Be sure that you do not load too much paper in the paper feeder. You can load up to 100 pages.
- Try turning the stack of paper over in the paper feeder. Most packages of paper indicate the best side to print on with an arrow on the end of the package. Make sure the best side is loaded face down.

Appendix

Technical Specifications	A-2
Printer specifications	A-2
Interface specifications	A-7
Initialization	A-11
Command Summary	A-13
Sending printer commands	A-13
Using the command summary	A-13
General operation	A-13
Paper feeding	A-14
Page format	A-14
Print position motion	A-15
Font selection	A-15
Font enhancement	A-17
Spacing	A-17
Character handling	A-18
Bit image	A-20
Graphics	A-21
Character Tables	A-21

Technical Specifications

Printer specifications

Printing

Printing method: Drop on demand 48-nozzle ink jet matrix

Printable columns and printing speed:

Character pitch	Printable columns	Printing speed	Draft
10 cpi	80	165 cps	250 cps
12 cpi	96	198 cps	300 cps
15 cpi	120	248 cps	375 cps
17 cpi (10 cpi condensed)	137	283 cps	429 cps
20 cpi (12 cpi condensed)	160	330 cps	500 cps

cpi: characters per inch

cps: characters per second

Maximum Resolution: 360 x 360 dpi text, graphics

Printing direction: Bidirectional with logic-seeking for text and graphics. (The auto print direction can be set in the default-settings mode.)

Line spacing: 1/6 inch, 1/8 inch, or programmable in 1/360-inch increments

Paper feed speed: 82 milliseconds per 1/6-inch line

Input buffer: 8 KB when mixed text/graphics option in default-settings mode is set to ON

32 KB when mixed text/graphics option in default-settings mode is set to OFF

Bitmap fonts:

Font	10 cpi	12 cpi	15 cpi	Proportional
Epson Draft	○	○	○	-
Epson Roman	○	○	○	○
Epson Sans Serif	○	○	○	○
Epson Courier	○	○	○	-
Epson Prestige	○	○	○	-
Epson Script	○	○	○	-

Select other font/pitch combinations using ESC/P 2 commands. See the command summary later in this chapter for a list of commands.

Scalable fonts:

Font	Min pt	Max pt	Increments
Epson Roman	8	32	2 pt
Epson Sans Serif	8	32	2 pt
Epson Roman T	8	32	2 pt
Epson Sans Serif H	8	32	2 pt

Note: Roman T and Sans Serif H cannot be printed with the following character tables: PC437 Greek, PC852, PC853, PC857, PC869, MAZOWIA, Code MJK, ISO8859-7, ISO Latin 1T, Bulgaria. The Roman font is substituted.

Paper

Single sheets (Paper feeder):

Width	210 to 216 mm (8.2 to 8.5 inches)
Length	279 to 297 mm (11.0 to 11.7 inches)
Thickness	0.065 to 0.14 mm (0.0026 to 0.0055 inches)
Weight	64 to 90 g/m ² (18 to 24 lb) □ Use 90 g/m ² (24 lb) paper under normal temperature and humidity conditions.
Quality	Bond paper, plain paper

Single sheets (Manual insertion):

Width	182 to 216 mm (7.1 to 8.5 inches)
Length	257 to 297 mm (10.1 to 11.7 inches)
Thickness	0.065 to 0.11 mm (0.0026 to 0.0043 inches)
Weight	52 to 90 g/m ² (14 to 24 lb)
Quality	Bond Paper, plain paper

Note:

Use recycled paper under normal temperature and humidity conditions only. Poor quality paper may reduce print quality, as well as cause paper jams and other problems. If you encounter problems, switch to a higher grade of paper.

Envelopes (Manual insertion):

Size	No. 6	166 x 92 mm (6.5 x 3.6 inches)
	No. 10	240 x 104 mm (9.5 x 4.1 inches)
Thickness		0.16 to 0.52 mm (0.0063 to 0.0197 inches)
Weight		45 to 90 g/m ² (12 to 24 lb)
		<input type="checkbox"/> Use envelopes only under normal temperature and humidity conditions. <input type="checkbox"/> Insert envelopes long side first; use the manual feed slot only.
Quality		Bond paper, plain paper, air mail
		<input type="checkbox"/> Difference in thickness within printable area must be less than 0.25 mm.

Printable area:

Single sheets (paper feeder and manual insertion)

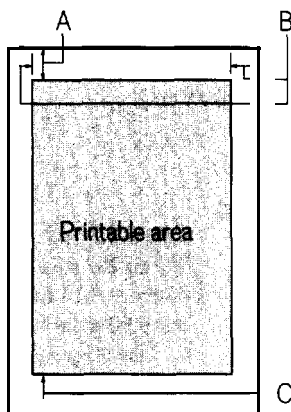

(See page A-5 for the values of A, B, and C.)

Envelopes:

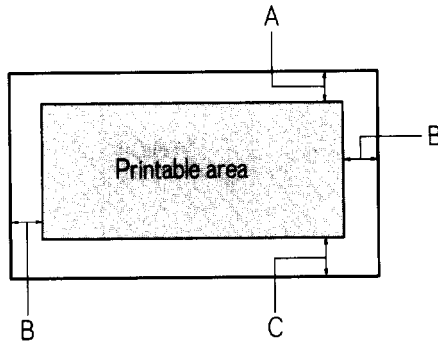

- A The minimum top margin is 3.0 mm (0.12 inches).
- B The minimum left and right margins is 3.0 mm (0.12 inches).
- C The minimum bottom margin is 13.0 mm (0.51 inches).

Mechanical

Paper-feed method:	Friction
Ink cartridge (S020025):	
Color:	Black
Print capacity:	Approximately 0.7 million characters in letter quality mode
Cartridge life:	2 years from production date (The cartridge life may vary, depending on how often you use the print head cleaning function.)
Temperature:	Storage: -30 to 40°C (-22 to 104°F) Transit: -30 to 60°C (-22 to 140°F) 1 month at 40°C (104°F) 120 hours at 60°C (140°F) Freezing: -3°C (26.6°F) thaws in approx 2 hours at 25°C (77°F)
MTBF:	4,000 power-on hours
Total print volume:	75,000 pages

Print head life:	1,000 million dots per nozzle								
Dimensions and weight:	<table> <tr> <td>Height</td> <td>154 mm (6.0 inches)</td> </tr> <tr> <td>Width</td> <td>435 mm (17.1 inches)</td> </tr> <tr> <td>Depth</td> <td>264 mm (10.4 inches) (no paper)</td> </tr> <tr> <td>Weight</td> <td>4.8 kg (10.6 lb)</td> </tr> </table>	Height	154 mm (6.0 inches)	Width	435 mm (17.1 inches)	Depth	264 mm (10.4 inches) (no paper)	Weight	4.8 kg (10.6 lb)
Height	154 mm (6.0 inches)								
Width	435 mm (17.1 inches)								
Depth	264 mm (10.4 inches) (no paper)								
Weight	4.8 kg (10.6 lb)								

Electrical

120 V model:

Rated voltage:	AC 120 V
Input voltage range:	AC 103.5 to 132 V
Rated frequency range:	50 to 60 Hz
Input frequency range:	49.5 to 60.5 Hz
Rated current:	0.5 A
Power consumption:	Approx. 13 W (during self-test printing in LQ mode at 10 cpi)

220-240 V model:

Rated voltage:	AC 220 to 240 V
Input voltage range:	AC 198 to 264 V
Rated frequency range:	50 to 60 Hz
Input frequency range:	49.5 to 60.5 Hz
Rated current:	0.3 A
Power consumption:	Approx. 13 W (during self-test printing in LQ mode at 10 cpi)

Note:

Check the label on the back of the printer for the voltage of your printer.

Environmental

Temperature:	<table> <tr> <td>Operation:</td> <td>10 to 35°C (50 to 95°F)</td> </tr> <tr> <td>Storage:</td> <td>-20 to 60°C (-4 to 140°F)</td> </tr> </table>	Operation:	10 to 35°C (50 to 95°F)	Storage:	-20 to 60°C (-4 to 140°F)
Operation:	10 to 35°C (50 to 95°F)				
Storage:	-20 to 60°C (-4 to 140°F)				

Humidity (without condensation): Operation: 20 to 80% RH
Storage: 5 to 85% RH

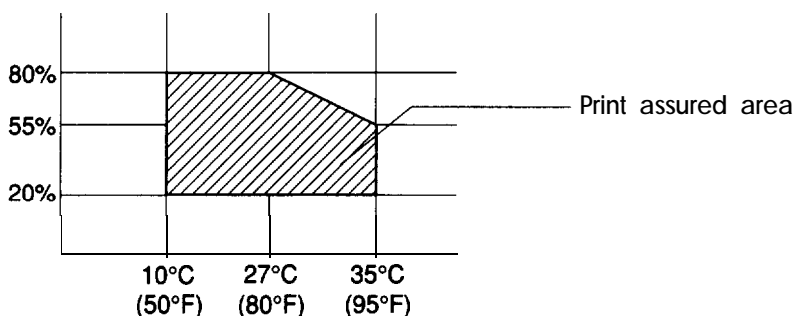

Safety approvals

Safety standards:

US model:

European model:

UL1950 with D3, CSA22.2 #220

EN 60950 (TÜV)

IEC 950 (SEMKO, DEMKO, NEMKO, SETI)

R.F.I.:

US model:

European model:

FCC Part 15 Subpart B class B

Vfg. 243 (VDE 0878 part 3, part 30)

EN 55022 (CISPR Pub 22) class B

Interface specifications

Your printer is equipped with an 8-bit parallel interface.

Specifications and pin assignments

The built-in parallel interface has the following characteristics:

Data format:

8-bit parallel

Synchronization:

$\overline{\text{STROBE}}$ pulse

Handshake timing:

BUSY and $\overline{\text{ACKNLG}}$ signals

Signal level:

TTL compatible

Connector:

36-pin 57-30360 Amphenol connector
or equivalent

The table below provides the connector pin assignments and describes their respective interface signals.

Signal Pin	Return Pin	Signal	Direction	Description
1	19	STROBE	IN	STROBE pulse to read data. Pulse width must be more than 0.5 microseconds at the receiving terminal.
2	20	DATA 1	IN	These signals represent information of bits 1 to 8 of parallel data, respectively. Each signal is at HIGH level when data is logical 1 and LOW when it is logical 0.
3	21	DATA 2	IN	
4	22	DATA 3	IN	
5	23	DATA 4	IN	
6	24	DATA 5	IN	
7	25	DATA 6	IN	
8	26	DATA 7	IN	
9	27	DATA 8	IN	
10	28	ACKNLG	OUT	About a 10-microsecond pulse. LOW indicates that data has been received and that the printer is ready to accept more data.
11	29	BUSY	OUT	A HIGH signal indicates the printer cannot receive data. The signal goes HIGH in the following cases: 1) During data entry (for each character) 2) During printing 3) During an error state
12	30	PE	OUT	A HIGH signal indicates the printer is in a paper-out state or in an error state.
13	-	SLCT	OUT	Pulled up to 5 V through 1.0 k Ω resistance
14		AUTO FEED XT	IN	When this signal is LOW, the paper is automatically fed one line after printing. (The signal level can be fixed to this by setting Auto Line Feed to on in the default-settings mode.)

Signal Pin	Return Pin	Signal	Direction	Description
15	-	NC	-	Not used
16	-	GND	-	Logic ground level
17	-	CHASSIS GND	-	Printer's chassis ground, which is isolated from the logic ground
18	-	NC	-	Not used
19-30	-	GND	-	Twisted-pair return signal ground level
31	16	$\overline{\text{INIT}}$	IN	When this level becomes LOW, the printer controller is reset to its power-on state and the print buffer is cleared. This level is normally HIGH: its pulse width must be more than 50 microseconds at the receiving terminal.
32	-	$\overline{\text{ERROR}}$	OUT	This level becomes LOW when the printer is: 1) out of paper 2) in an error state
33	-	GND	-	Same as for pins 19-30
34	-	NC	-	Not used
35	-	-	OUT	Pulled up to 5 V through 1.0 k Ω resistance
36	-	NC	-	Not used

Note:

- ❑ The column heading "Direction" refers to the direction of signal flow as viewed from the printer.
- ❑ "Return" denotes the twisted-pair return, to be connected at signal ground level. For the interface wiring, be sure to use a twisted-pair cable for each signal and to complete the connection on the return side.
- ❑ All interface conditions are based on the TTL level. Both the rise and fall times of each signal must be less than 0.2 microseconds,

Interface timing

The figure below shows the timing for the parallel interface.

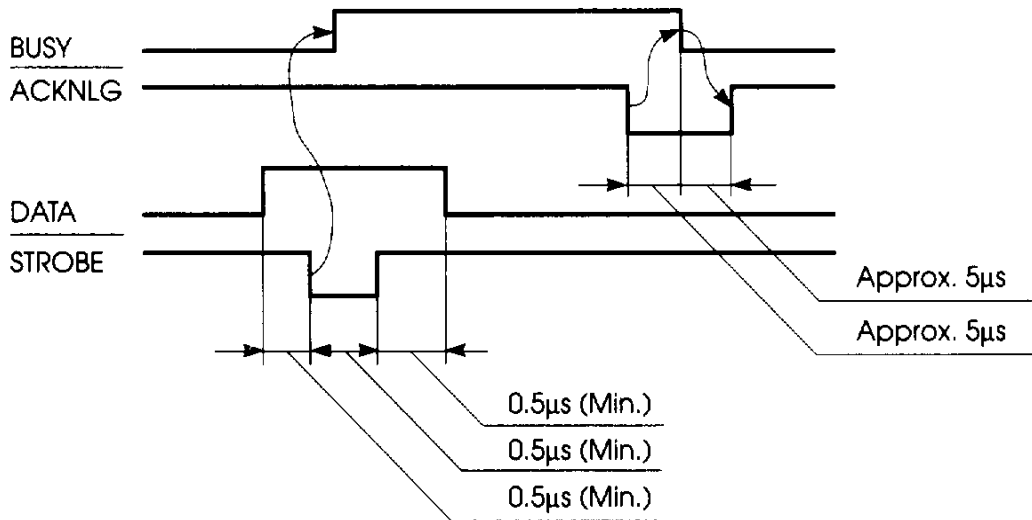

Initialization

The printer can be initialized (returned to a fixed set of conditions) in three ways:

Hardware initialization	<ul style="list-style-type: none">• The power is turned on, _____• The printer receives an INIT signal from the parallel interface (pin 31 goes LOW). <p>The following condition then results:</p> <ol style="list-style-type: none">1) The printer mechanism is initialized.2) The input data buffer is cleared.3) The download character set is cleared.4) The print buffer is cleared.5) The default values are set.
Software initialization	<ul style="list-style-type: none">• Software sends the ESC @ (initialize the printer) command. <p>The following condition then results:</p> <ol style="list-style-type: none">1) The print buffer is cleared.2) The default values are set. (The last panel settings are maintained.)
Control panel initialization	<ul style="list-style-type: none">• Hold down the ALT button and press the LOAD/EJECT button. <p>The following results:</p> <ol style="list-style-type: none">1) The input data buffer is cleared.2) The print buffer is cleared.3) The default values are set. (The last panel settings are kept.)

Default settings

The table below shows the default settings that take effect when the printer is initialized.

Item	Default setting
Top-of-form position	Current paper position
Page length	Single sheets: 65 lines for A1-size paper 61 lines for letter-size paper 22 inches for manual insertion
Left and right margins	Cancelled
Line spacing	1/6-inch line spacing
Character size	10.5 point
Vertical tab position	Cleared
Horizontal tab positions	Every eight characters
Font selection	Lost font selected on control panel
Special printing effects	Cancelled (except condensed printing)
Download character set	Hardware initialization: cleared Software/control panel Initialization: deselected only

In addition, hardware and control panel initialization clears the data buffer.

Command Summary

Sending printer commands

Most actions your printer performs are handled by your software. Software commands instruct the printer to print in a particular typeface, feed the paper a certain amount after printing each line, start printing a particular place on the page, and so on.

Some software programs let you send these commands yourself. This allows you to enhance your printing in ways that may not normally be available through the software. For example, some word processing programs do not offer italics, but by inserting a command in your document, you can use italics anywhere you like. The commands your printer recognizes are listed in this command summary.

How you format commands depends on the software you are using. Some software programs accept only the decimal format, while others let you type in ASCII characters. (Some programs don't let you insert printer commands at all.) In addition, your software probably specifies certain punctuation you must use to enter the command. If your software allows you to send commands to the printer, the software manual should explain exactly what format and punctuation are required.

Using the command summary

The following section lists and describes all the commands by topic. If a command has no parameters, it is merely listed. If it has parameters, they are explained. The parameters are indicated by lowercase letters, usually n. The examples below show how the parameters are indicated.

ESC@ is a command with no parameters.

ESC U1/0 is a command that uses 1 to turn the feature on and 0 to turn it off.

ESC \$ n1n2 is a command with two parameters.

ESC D n is a command with a variable number of parameters.

General operation

ASCII	Dec.	Hex.	Description
ESC @	64	40	Initialize Printer

ASCII	Dec.	Hex.	Description
ESC U I/O	85	55	Turn Unidirectional Mode On/Off
ESC EM n	25	19	Control Paper Loading/Ejecting n = "R" Eject a sheet

Paper feeding

ASCII	Dec.	Hex.	Description
CR	13	0D	Carriage Return
FF	12	0C	Form Feed
LF	10	0A	Line Feed
ESC 0	48	30	Select 1/8-inch Line Spacing
ESC 2	50	32	Select 1/6-inch Line Spacing
ESC 3 n	51	33	Set n/180-inch Line Spacing
ESC + n	43	2B	Set n/360-inch Line Spacing

Page format

ASCII	Dec.	Hex.	Description
ESC (c nn	40 99	28 63	Set Page Format ESC (c 4 0 m1 m2 n1 n2 m = m1 + m2 x 256 m: Top margin in defined units n = n1 + n2 x 256 n: Bottom margin in defined units
ESC (C nn	40 67	28 43	Set Page Length in Defined Unit ESC (C 2 0 n1 n2 n = n1 + n2 x 256 n: Number of defined units
ESC C n	67	43	Set Page Length In Lines n = Number of lines
ESC C 0 n	67	43	Set Page Length in Inches n = Number of inches
ESC l n	108	6C	Set Left Margin n = Left margin column
ESC Q n	81	51	Set Right Margin n = Right margin column

Print position motion

ASCII	Dec.	Hex.	Description
ESC \$ n1 n2	36	24	Set Absolute Horizontal Print Position $n = n1 + n2 \times 256$ n: Specifies print position from left margin in defined units <ul style="list-style-type: none"> • Before you define the unit, the default is 1/60 inch for this command.
ESC \ n1 n2	92	5C	Set Relative Horizontal Print Position $n = n1 + n2 \times 256$ n: Moves current print position in defined units <ul style="list-style-type: none"> * Before you define the unit, the default is 1/120 inch in draft and 1/180 inch in LQ for this command.
ESC (V nn	40 86	28 56	Set Absolute Vertical Print Position ESC (V 2 0 n1 n2 $n = n1 + n2 \times 256$ n: Specifies print position from top margin in defined units
ESC (v nn	40 118	28 76	Set Relative Vertical Print Position ESC (v 2 0 n1 n2 $n = n1 + n2 \times 256$ n: Moves current print position in defined units
ESC D nn	68	44	Set Horizontal Tabs Up to 32 tabs entered in ascending order Terminated by 0
HT	9	09	Tab Horizontally
ESC B nn	66	42	Set Vertical Tabs Up to 16 tabs; lost n should be 0
VT	11	0B	Tab Vertically
ESC J n	74	4A	Advance paper n/180 inch

Font selection

ASCII	Dec.	Hex.	Description
ESC k n	107	6B	Select Typeface $n = 0$: Roman 4: Script 1: Sons Serif 10: Roman T 2: Courier 11: Sons Serif H 3: Prestige

ASCII	Dec.	Hex.	Description
ESC X n n	88	58	Select Font by Pitch and Point ESC X m n1 n2 m : Set pitch to 360/m cpi m = 0 : No change in pitch m = 1 : Select proportional m = 0, 1, 18, 21, 24, 30, 36, 42, 48, 60, or 72 n = n1 + n2 x 256 n : Set point size in 0.5 points Total points = (n1 + n2 x 256) x 0.5 n = 0 : No change in point n = 0, 16, 21, 24, 28, 32, 36, 40, 44, 48, 52, 56, 60, or 64 (for Roman, Sons Serif Roman T, and Sons Serif H.) n = 0, 21, 42 (for other typefaces) . Cancel ESC X with ESC P, M g, p, l, or @
ESC P	80	50	Select 10.5 point, 10 cpi
ESC M	77	4D	Select 10.5 point, 12 cpi
ESC g	103	67	Select 10.5 point, 15 cpi
ESC p l / O	112	70	Turn Proportional Mode On/Off
ESC x n	120	78	Select LQ or Draft n = 0 : Draft 1 : LQ
ESC 4	52	34	Select <i>Italic</i> Font
ESC 5	53	35	Cancel <i>Italic</i> Font
ESC E	69	45	Select Bold Font
ESC F	70	46	Cancel Bold Font
ESC ! n	33	21	Master Select To find the value of n , odd together the numbers of the font attributes and enhancements you want to combine from the list below: n = 0 : 10 cpi 16: Double-strike 1 : 12 cpi 32: Double-width 2 : Proportional 64: <i>Italic</i> 4 : Condensed 128: Underline 8 : Bold

Font enhancement

ASCII	Dec.	Hex.	Description
SI	15	0F	Select Condensed Printing
DC2	18	12	Cancel Condensed Printing
so	14	0E	Select Double-Width Printing (one line)
ESC W I/O	87	57	Turn Double-Width Printing On/Off
DC4	20	14	Cancel Double-Width Printing (one line)
ESC w I/O	119	77	Turn Double-Height Printing On/Off
ESC G	71	47	Select Double-Strike Printing
ESC H	72	48	Cancel Double-Strike Printing
ESC S 0	83	53	Select Superscript Printing
ESC S 1	83	53	Select Subscript Printing
ESC T	84	54	Cancel Superscript/Subscript Printing
ESC (- nn	40 45	28 2D	Select Line/Score ESC (- 3 0 1 n1 n2 n1 = 1: Underline 2: Strikethrough 3: Overscore n2 = 0: Cancel score line selected by n1 1: Single continuous line 2: Double continuous line 5: Single broken line 6: Double broken line
ESC - I/O	45	2D	Turn Underline On/Off
ESC q n	113	71	Select Character Style n = 0: Normal style 1: Outline 2: Shadow 3: Outline with shadow

Spacing

ASCII	Dec.	Hex.	Description
ESC SP n	32	20	Set Intercharacter Space n = Number of units of space added to the space between characters Units are 1 /120 inch (draft) and 1 /180 inch (LQ and proportional)

ASCII	Dec.	Hex.	Description
ESC (U n n	40 85	28 55	Define Unit ESC (U 1 On Define positioning unit as n/3600 inch n = 10, 20, 30, 40, 50, or 60 n = 10: default
ESC c n1 n2	99	63	Set Horizontal Motion Index (HMI) Select Pitch in n/360-inch units Total units = n1 + n2 x 256

Character handling

ASCII	Dec.	Hex.	Description
ESC (t n n	40 116	28 74	Assign Character Table ESC (t 3 0 d1 d2 d3 Assign Character Table set with d2 and d3 to table d1 d1 = 0, 1, 2, 3, 48, 49, 50, or 51 d2 d3 Character Table 0 0 Italic 1 0 PC437 (USA) 1 16 PC 437 Greek (Greek)* 3 0 PC 850 (Multilingual) 5 0 PC 853 (Turkish)* 6 0 PC 855 (Cyrillic)* 7 0 PC 860 (Portuguese)' 8 0 PC 863 (Canada-French)* 9 0 PC 865 (Norway)' 10 0 PC 852 (East Europe)'' 11 0 PC 857 (Turkish)* 14 0 PC 866 (Russian)' 15 0 PC 869* 24 0 PC 861* 25 0 BRAScii(Brazilian Portuguese)' 26 0 Abicomp(Brazilian Portuguese)* 27 0 PC 869* 28 0 Code MJK 29 112 ISO 8859-7* 31 0 ISO Latin 1T 32 0 Bulgaria' 'Availability varies by country.
ESC t n	116	74	Select Character Table Select character table n assigned by ESC (t n = 0, 1, 2, 3, 48, 49, 50, or 51

ASCII	Dec.	Hex.	Description
ESC † n	116	74	n = 2: Remaps download characters from 0 – 127 to 128 – 255 (unless a character table has been assigned to 2 with the ESC († command)
ESC R n	82	52	Select an International Character Set n = 0: USA 1: France 2: Germany 3: UK 4: Denmark I 5: Sweden 6: Italy 7: Spain I 8: Japan 9: Norway 10: Denmark 11: Spain II 12: Latin America 13: Korea 64: Legal
ESC & n n	38	26	Define User-Defined Character ESC & 0 n1 n2 d0 d1 d2 data n1 = First character number n2 = Last character number d0 = Left space of character d1 = Body width of character d2 = Right space of character data: 3 bytes required for each character; super/subscript requires only 2 bytes per character
ESC : 0 n 0	58	3A	Copy ROM to RAM n = 0, 1, 2, 3, 4, 10, or 11 n: Typeface (see list in ESC k command description)
ESC % n	37	25	Select User-Defined Set n = 0: Normal set 1: User-defined set
ESC 6	54	36	Enable Printing of Upper Control Codes This command enables the printing of codes 128–159 (if current table has characters in those locations).
ESC 7	55	37	Enable Upper Control Codes Cancels ESC 6
ESC (^ n n	40 94	28 5E	Print Data as Characters ESC (^ n1 n2 data n = n1 + n2 x 256 n: Amount of data data: The following n bytes of data printed as characters

Bit image

ASCII	Dec.	Hex.	Description
ESC . nn	42	2A	Select Bit Image ESC * m n1 n2 data n = n1 + n2 x 256 n: Total columns Total data = (n1 + n2 x 256) x † † = Number of data bytes per column

m	Horizontal density (dpi)	Vertical density (dpi)	Pins	Adjacent dots print	†
0	60	60	8	Yes	1
1	120	60	8	Yes	1
2	120	60	8	No	1
3	240	60	8	No	1
4	80	60	8	Yes	1
6	90	60	8	Yes	1
32	60	180	24	Yes	3
33	120	180	24	Yes	3
38	90	180	24	Yes	3
39	180	180	24	Yes	3
40	360	180	24	Yes	3
71	180	360	48	Yes	6
72	360	360	48	No	6
73	360	360	48	Yes	6

Graphics

ASCII	Dec.	Hex.	Description
ESC (G nn	40 71	28 47	Select Graphics Mode ESC (G 1 On n = 1 or 49 . Cancel Graphics mode with ESC @
ESC nn	46	2E	Print Raster Graphics ESC . c v h m n1 n2 data c = 0: Full graphics mode 1: Compressed mode v = 10, 20: Dot density for vertical in 3600/v DPI h = 10, 20: Dot density for horizontal in 3600/h DPI m: Number of vertical dots 1 ≤ m ≤ 24 n: Number of horizontal dots Total dots = n1 + n2 × 256 . The following combination is not allowed: v = 10 and h = 20

Character Tables

These character tables are selected with the default-setting mode or by using a command.

All tables except the italic character table are the same as the PC437 table for hex codes 00 through 7F, so only the PC437 and italic tables are shown completely. The rest of the tables show only the characters for hex codes 80 through FF.

The availability of the tables with * after the table name varies by country.

PC437

CODE	0	1	2	3	4	5	6	7	8	9	A	B	C	D	E	F
0	NUL			0	@	P	`	p	Ç	É	á	⌘	L	⌞	a	≡
1			!	1	A	Q	a	q	Û	æ	í	⌘	⌞	⌞	β	±
2		DC2	"	2	B	R	b	r	é	Æ	ó	⌘	⌞	⌞	⌞	±
3			#	3	C	S	c	s	â	ô	ú	⌘	⌞	⌞	⌞	±
4		DC4	\$	4	D	T	d	t	ä	ö	ñ	⌘	⌞	⌞	⌞	±
5		S	%	5	E	U	e	u	à	ò	ñ	⌘	⌞	⌞	⌞	±
6			&	6	F	V	f	v	â	ô	ñ	⌘	⌞	⌞	⌞	±
7			'	7	G	W	g	w	ç	ù	Q	⌘	⌞	⌞	⌞	±
8			(8	H	X	h	x	è	ÿ	Ö	⌘	⌞	⌞	⌞	±
9	HT	EM)	9	I	Y	i	y	è	ÿ	Ö	⌘	⌞	⌞	⌞	±
A	LF		*	A	J	Z	j	z	è	ÿ	Ö	⌘	⌞	⌞	⌞	±
B	VT	ESC	+	B	K	[k	{	è	ÿ	Ö	⌘	⌞	⌞	⌞	±
C	FF		,	C	L]	l	}	è	ÿ	Ö	⌘	⌞	⌞	⌞	±
D	CR		=	D	M	^	m	~	è	ÿ	Ö	⌘	⌞	⌞	⌞	±
E	SO		>	E	N	~	n		è	ÿ	Ö	⌘	⌞	⌞	⌞	±
F	SI		/	F	O	_	o		è	ÿ	Ö	⌘	⌞	⌞	⌞	±

PC850

CODE	8	9	A	B	C	D	E	F
0	Ç	É	á	⌘	L	ö	6	—
1	Û	æ	í	⌘	⌞	ö	β	±
2	é	Æ	ó	⌘	⌞	ö	ö	±
3	â	ô	ú	⌘	⌞	ö	ö	±
4	ä	ö	ñ	⌘	⌞	ö	ö	±
5	à	ò	ñ	⌘	⌞	ö	ö	±
6	â	û	a	⌘	⌞	ö	ö	±
7	ç	ù	Q	⌘	⌞	ö	ö	±
8	è	ÿ	Ö	⌘	⌞	ö	ö	±
9	è	ÿ	Ö	⌘	⌞	ö	ö	±
A	è	ÿ	Ö	⌘	⌞	ö	ö	±
B	è	ÿ	Ö	⌘	⌞	ö	ö	±
C	è	ÿ	Ö	⌘	⌞	ö	ö	±
D	è	ÿ	Ö	⌘	⌞	ö	ö	±
E	è	ÿ	Ö	⌘	⌞	ö	ö	±
F	è	ÿ	Ö	⌘	⌞	ö	ö	±

PC860 .

PC863 *

CODE	8	9	A	B	C	D	E	F
0	Ç	È	á	⋯	⊥	⊥	α	≡
1	Û	É	í	⋯	⊥	⊥	β	±
2	é	À	ó	⋯	⊥	⊥	Γ	≠
3	â	Ê	ú	⋯	⊥	⊥	Π	≤
4	ã	Ë	ñ	⋯	⊥	⊥	Σ	√
5	à	Ò	Ñ	⋯	⊥	⊥	σ	∫
6	Ç	Ù	á	⋯	⊥	⊥	μ	÷
7	È	Ì	ó	⋯	⊥	⊥	τ	·
8	É	Ï	ô	⋯	⊥	⊥	θ	°
9	Ê	Ö	õ	⋯	⊥	⊥	ω	·
A	È	Û	ñ	⋯	⊥	⊥	δ	·
B	É	Ï	ó	⋯	⊥	⊥	ε	·
C	Ê	Ö	õ	⋯	⊥	⊥	ø	·
D	È	Û	ñ	⋯	⊥	⊥	ø	·
E	É	Ï	ó	⋯	⊥	⊥	ε	·
F	Ê	Ö	õ	⋯	⊥	⊥	ε	·

CODE	8	9	A	B	C	D	E	F
0	Ç	È	á	⋯	⊥	⊥	α	≡
1	Û	É	í	⋯	⊥	⊥	β	±
2	é	À	ó	⋯	⊥	⊥	Γ	≠
3	â	Ê	ú	⋯	⊥	⊥	Π	≤
4	ã	Ë	ñ	⋯	⊥	⊥	Σ	√
5	à	Ò	Ñ	⋯	⊥	⊥	σ	∫
6	Ç	Ù	á	⋯	⊥	⊥	μ	÷
7	È	Ì	ó	⋯	⊥	⊥	τ	·
8	É	Ï	ô	⋯	⊥	⊥	θ	°
9	Ê	Ö	õ	⋯	⊥	⊥	ω	·
A	È	Û	ñ	⋯	⊥	⊥	δ	·
B	É	Ï	ó	⋯	⊥	⊥	ε	·
C	Ê	Ö	õ	⋯	⊥	⊥	ø	·
D	È	Û	ñ	⋯	⊥	⊥	ø	·
E	É	Ï	ó	⋯	⊥	⊥	ε	·
F	Ê	Ö	õ	⋯	⊥	⊥	ε	·

PC865*

PC861*

CODE	8	9	A	B	C	D	E	F
0	Ç	È	á	⋯	⊥	⊥	α	≡
1	Û	É	í	⋯	⊥	⊥	β	±
2	é	À	ó	⋯	⊥	⊥	Γ	≠
3	â	Ê	ú	⋯	⊥	⊥	Π	≤
4	ã	Ë	ñ	⋯	⊥	⊥	Σ	√
5	à	Ò	Ñ	⋯	⊥	⊥	σ	∫
6	Ç	Ù	á	⋯	⊥	⊥	μ	÷
7	È	Ì	ó	⋯	⊥	⊥	τ	·
8	É	Ï	ô	⋯	⊥	⊥	θ	°
9	Ê	Ö	õ	⋯	⊥	⊥	ω	·
A	È	Û	ñ	⋯	⊥	⊥	δ	·
B	É	Ï	ó	⋯	⊥	⊥	ε	·
C	Ê	Ö	õ	⋯	⊥	⊥	ø	·
D	È	Û	ñ	⋯	⊥	⊥	ø	·
E	É	Ï	ó	⋯	⊥	⊥	ε	·
F	Ê	Ö	õ	⋯	⊥	⊥	ε	·

CODE	8	9	A	B	C	D	E	F
0	Ç	È	á	⋯	⊥	⊥	α	≡
1	Û	É	í	⋯	⊥	⊥	β	±
2	é	À	ó	⋯	⊥	⊥	Γ	≠
3	â	Ê	ú	⋯	⊥	⊥	Π	≤
4	ã	Ë	ñ	⋯	⊥	⊥	Σ	√
5	à	Ò	Ñ	⋯	⊥	⊥	σ	∫
6	Ç	Ù	á	⋯	⊥	⊥	μ	÷
7	È	Ì	ó	⋯	⊥	⊥	τ	·
8	É	Ï	ô	⋯	⊥	⊥	θ	°
9	Ê	Ö	õ	⋯	⊥	⊥	ω	·
A	È	Û	ñ	⋯	⊥	⊥	δ	·
B	É	Ï	ó	⋯	⊥	⊥	ε	·
C	Ê	Ö	õ	⋯	⊥	⊥	ø	·
D	È	Û	ñ	⋯	⊥	⊥	ø	·
E	É	Ï	ó	⋯	⊥	⊥	ε	·
F	Ê	Ö	õ	⋯	⊥	⊥	ε	·

BRASCI1*

CODE	8	9	A	B	C	D	E	F
0	NUL		°	À	Ð	à	ð	
1			±	Á	Ñ	á	ñ	
2	DC2		ϕ	Â	Ò	â	ò	
3			£	Ã	Ó	ã	ó	
4	DC4		□	Ä	Ô	ä	ô	
5			¥	Å	Õ	å	õ	
6			¦	Æ	Ö	æ	ö	
7			§	Ç	Ø	ç	ø	
6			¨	È	Ù	è	ù	
9	HT	EM	©	É	Ú	é	ú	
A	LF		ª	Ê	Û	ê	û	
B	VT	ESC	«	Ë	Ü	ë	ü	
C	FF		»	Ì	Ý	ì	ý	
D	CR		¬	Í	Þ	í	þ	
E	SO		®	Î	ß	î	ÿ	
F	SI		¯	Ï	β	ï	ÿ	

Abicom1*

CODE	8	9	A	B	C	D	E	F
0	NUL			Ò	ì	ò		
1			A	6	à	6		
2	DC2		À	6	á	6		
3			A	6	â	a		
4	DC4		À	6	ã	6		
5			À	6	ä	æ		
6			Ç	6	ç	ù		
7			È	6	è	ú		
8			É	6	é	û		
9	HT	EM	Ê	6	ê	ü		
A	LF		Ë	6	ë	ÿ		
B	VT	ESC	Ì	6	ì	β		
C	FF		Í	6	í	α		
D	CR		Î	6	î	Ω		
E	SO		Ï	6	ï	ζ		
F	SI		Ñ	6	ñ	±		DEL

PC437 Greek*

CODE	8	9	A	B	C	D	E	F
0	À	Ρ	Ι	⋮	⊥	⊥	ω	Ω
1	Β	Σ	Κ	⋮	⊥	⊥	ά	±
2	Γ	Τ	Λ	⋮	⊥	⊥	έ	≥
3	Δ	Υ	Μ	⋮	⊥	⊥	ή	≤
4	Ε	Φ	Ν	⋮	⊥	⊥	ί	∩
5	Ζ	Χ	Ξ	⋮	⊥	⊥	ό	∪
6	Η	Ψ	Ο	⋮	⊥	⊥	ώ	÷
7	Θ	Ω	Π	⋮	⊥	⊥	ύ	·
8	Ι	α	ρ	⋮	⊥	⊥	ű	°
9	Κ	β	σ	⋮	⊥	⊥	ő	£
A	Λ	γ	ς	⋮	⊥	⊥	á	¥
B	Μ	δ	τ	⋮	⊥	⊥	ä	√
C	Ν	ε	υ	⋮	⊥	⊥	å	n
D	Ξ	ζ	φ	⋮	⊥	⊥	æ	²
E	Ο	η	χ	⋮	⊥	⊥	ä	■
F	Π	θ	ψ	⋮	⊥	⊥	ä	■

PC852*

CODE	8	9	A	B	C	D	E	F
0	Ç	É	Á	⋮	⊥	đ	Ó	~
1	ü	Ł	í	⋮	⊥	Đ	Ö	˘
2	é	í	ó	⋮	⊥	Đ	Ö	˘
3	â	ô	ú	⋮	⊥	È	Ń	˘
4	ä	ö	Å	⋮	⊥	È	Ń	˘
5	û	Ł	ą	⋮	⊥	À	Ń	˘
6	ù	ć	ż	⋮	⊥	À	Ń	˘
7	ç	ś	ź	⋮	⊥	È	Ń	˘
6	ł	ś	ż	⋮	⊥	È	Ń	˘
9	è	Ů	e	⋮	⊥	È	Ń	˘
A	Ó	Ů	t	⋮	⊥	È	Ń	˘
B	ô	í	t	⋮	⊥	È	Ń	˘
C	î	ž	š	⋮	⊥	È	Ń	˘
D	ž	š	š	⋮	⊥	È	Ń	˘
E	À	×	«	⋮	⊥	È	Ń	˘
F	Ć	ć	»	⋮	⊥	È	Ń	˘

PC853*

CODE	8	9	A	B	C	D	E	F
0	Ç	É	á	⋮	⊥	Ó	Ó	-
1	ü	é	í	⋮	⊥	Ó	Ó	±
2	é	é	ó	⋮	⊥	Ó	Ó	±
3	ä	ö	ú	⋮	⊥	Ó	Ó	±
4	ä	ö	ñ	⋮	⊥	Ó	Ó	±
5	ä	ö	ñ	⋮	⊥	Ó	Ó	±
6	ä	ö	ñ	⋮	⊥	Ó	Ó	±
7	ç	è	ì	⋮	⊥	Ó	Ó	±
8	è	è	ò	⋮	⊥	Ó	Ó	±
9	è	è	ò	⋮	⊥	Ó	Ó	±
A	è	è	ò	⋮	⊥	Ó	Ó	±
B	è	è	ò	⋮	⊥	Ó	Ó	±
C	è	è	ò	⋮	⊥	Ó	Ó	±
D	è	è	ò	⋮	⊥	Ó	Ó	±
E	è	è	ò	⋮	⊥	Ó	Ó	±
F	è	è	ò	⋮	⊥	Ó	Ó	±

PC855*

CODE	8	9	A	B	C	D	E	F
0	Ъ	Ь	а	⋮	⊥	Л	Я	-
1	Ъ	Ь	а	⋮	⊥	Л	Я	ы
2	Ъ	Ь	а	⋮	⊥	Л	Я	ы
3	Ъ	Ь	а	⋮	⊥	Л	Я	ы
4	Ъ	Ь	а	⋮	⊥	Л	Я	ы
5	Ъ	Ь	а	⋮	⊥	Л	Я	ы
6	Ъ	Ь	а	⋮	⊥	Л	Я	ы
7	Ъ	Ь	а	⋮	⊥	Л	Я	ы
8	Ъ	Ь	а	⋮	⊥	Л	Я	ы
9	Ъ	Ь	а	⋮	⊥	Л	Я	ы
A	Ъ	Ь	а	⋮	⊥	Л	Я	ы
B	Ъ	Ь	а	⋮	⊥	Л	Я	ы
C	Ъ	Ь	а	⋮	⊥	Л	Я	ы
D	Ъ	Ь	а	⋮	⊥	Л	Я	ы
E	Ъ	Ь	а	⋮	⊥	Л	Я	ы
F	Ъ	Ь	а	⋮	⊥	Л	Я	ы

PC857*

CODE	8	9	A	B	C	D	E	F
0	Ç	É	á	⋮	⊥	Ó	Ó	-
1	ü	é	í	⋮	⊥	Ó	Ó	±
2	é	é	ó	⋮	⊥	Ó	Ó	±
3	ä	ö	ú	⋮	⊥	Ó	Ó	±
4	ä	ö	ñ	⋮	⊥	Ó	Ó	±
5	ä	ö	ñ	⋮	⊥	Ó	Ó	±
6	ä	ö	ñ	⋮	⊥	Ó	Ó	±
7	ç	è	ì	⋮	⊥	Ó	Ó	±
8	è	è	ò	⋮	⊥	Ó	Ó	±
9	è	è	ò	⋮	⊥	Ó	Ó	±
A	è	è	ò	⋮	⊥	Ó	Ó	±
B	è	è	ò	⋮	⊥	Ó	Ó	±
C	è	è	ò	⋮	⊥	Ó	Ó	±
D	è	è	ò	⋮	⊥	Ó	Ó	±
E	è	è	ò	⋮	⊥	Ó	Ó	±
F	è	è	ò	⋮	⊥	Ó	Ó	±

PC866*

CODE	8	9	A	B	C	D	E	F
0	А	Р	а	⋮	⊥	Д	Р	ё
1	А	Р	а	⋮	⊥	Д	Р	ё
2	А	Р	а	⋮	⊥	Д	Р	ё
3	А	Р	а	⋮	⊥	Д	Р	ё
4	А	Р	а	⋮	⊥	Д	Р	ё
5	А	Р	а	⋮	⊥	Д	Р	ё
6	А	Р	а	⋮	⊥	Д	Р	ё
7	А	Р	а	⋮	⊥	Д	Р	ё
8	А	Р	а	⋮	⊥	Д	Р	ё
9	А	Р	а	⋮	⊥	Д	Р	ё
A	А	Р	а	⋮	⊥	Д	Р	ё
B	А	Р	а	⋮	⊥	Д	Р	ё
C	А	Р	а	⋮	⊥	Д	Р	ё
D	А	Р	а	⋮	⊥	Д	Р	ё
E	А	Р	а	⋮	⊥	Д	Р	ё
F	А	Р	а	⋮	⊥	Д	Р	ё

PC869*

CODE	8	9	A	B	C	D	E	F
0	ı	ı			L	T	ç	-
1	ı	ı			L	Y	η	±
2	0	ó			T	ϕ	9	u
3		ú			T	X	ı	φ
4		á			T	ψ	κ	χ
5	Y	á			T	Ω	λ	σ
6	A	Ψ			T	α	μ	ψ
7	·	Ω			T	β	ν	Ψ
8	·	·			T	γ	ο	·
9	·	·			T	ı	π	·
A	·	·			T	ı	ρ	·
B	·	·			T	ı	σ	·
C	·	·			T	ı	τ	·
D	·	·			T	ı	υ	·
E	·	·			T	ı	ω	·
F	·	·			T	ı	ı	·

MAZOWIA.

CODE	8	9	A	B	C	D	E	F
0	ç	ę	ż		L	ł	α	±
1	ü	ę	ó		L	ł	β	±
2	é	ı	ó		T	ł	γ	±
3	ä	ö	ó		T	ł	π	±
4	ä	ö	ó		T	ł	σ	±
5	ä	ö	ó		T	ł	μ	±
6	ä	ö	ó		T	ł	τ	±
7	ä	ö	ó		T	ł	φ	±
8	ä	ö	ó		T	ł	θ	±
9	ä	ö	ó		T	ł	ω	±
A	ä	ö	ó		T	ł	δ	±
B	ä	ö	ó		T	ł	ε	±
C	ä	ö	ó		T	ł	ø	±
D	ä	ö	ó		T	ł	ε	±
E	ä	ö	ó		T	ł	ε	±
F	ä	ö	ó		T	ł	ε	±

Code MJK*

CODE	8	9	A	B	C	D	E	F
0	č	š	á		L	ł	α	±
1	ü	ž	í		L	ł	β	±
2	é	ž	ó		T	ł	γ	±
3	đ	ž	ó		T	ł	π	±
4	ä	ö	ó		T	ł	σ	±
5	đ	ö	ó		T	ł	μ	±
6	č	ü	ó		T	ł	τ	±
7	č	ü	ó		T	ł	φ	±
8	č	ü	ó		T	ł	θ	±
9	č	ü	ó		T	ł	ω	±
A	č	ü	ó		T	ł	δ	±
B	č	ü	ó		T	ł	ε	±
C	č	ü	ó		T	ł	ø	±
D	č	ü	ó		T	ł	ε	±
E	č	ü	ó		T	ł	ε	±
F	č	ü	ó		T	ł	ε	±

ISO 8859-7*

CODE	8	9	A	B	C	D	E	F
0					ı	π	ı	π
1					A	P	α	ρ
2					B	P	β	σ
3					Γ	Σ	γ	τ
4					Δ	Τ	δ	υ
5					E	Υ	ε	φ
6					Z	Φ	ç	χ
7					H	Ψ	η	ψ
6					Θ	Ω	θ	ω
9					I	ı	ı	ı
A					K	ı	ı	ı
B					ı	ı	ı	ı
C					ı	ı	ı	ı
D					ı	ı	ı	ı
E					ı	ı	ı	ı
F					ı	ı	ı	ı

ISO Latin 1T*

Bulgaria .

CODE	B	9	A	B	C	D	E	F
0				.	À	Ñ	à	ñ
1			;	±	Á	Ñ	á	ñ
2			;	±	À	Ò	â	ò
3			;	±	À	Ó	ã	ó
4			;	±	À	Ô	ä	ô
5			;	±	À	Õ	å	õ
6			;	±	À	Ö	æ	ö
7			;	±	Ç	×	ç	÷
8			;	±	È	Ø	é	ø
9			;	±	É	Ù	ê	ù
A			;	±	È	Ú	ë	ú
B			;	±	É	Û	è	û
C			;	±	Ì	Ü	í	ü
D			;	±	Í	Ý	î	ÿ
E			;	±	Î	Ş	ï	ş
F			;	±	Ï	ß	ï	ÿ

CODE	8	9	A	B	C	D	E	F
0	А	Р	а	р	⌈	▒	а	≡
1	Б	С	б	с	└	▒	в	±
2	В	Т	в	т	┌	▒	г	≡
3	Г	У	г	у	└	▒	д	≡
4	Д	Ф	д	ф	┌	▒	е	≡
5	Е	Х	е	х	└	▒	ж	≡
6	Ж	Ц	ж	ц	┌	▒	з	≡
7	З	Ч	з	ч	└	▒	и	≡
6	И	Ш	и	ш	┌	▒	ф	≡
9	Й	Щ	й	щ	└	▒	о	≡
A	К	Ъ	к	ъ	┌	▒	р	≡
B	Л	Ь	л	ь	└	▒	с	≡
C	М	Н	м	н	┌	▒	д	≡
D	Н	Э	н	э	└	▒	в	≡
E	О	Ю	о	ю	┌	▒	е	≡
F	П	Я	п	я	└	▒	ш	≡

Italic

No characters are available for hex code 15 in the italic character table.

CODE	8	9	A	B	C	D	E	F
0	NUL		0	@	P	`	p	
1		!	1	A	Q	a	q	
2	DC2	"	2	B	R	b	r	
3		#	3	C	S	c	s	
4	DC4	\$	4	D	T	d	t	
5		%	5	E	U	e	u	
6		&	6	F	V	f	v	
7		'	7	G	W	g	w	
8		(8	H	X	h	x	
9	HT	EM)	9	I	Y	i	y
A	LF	*	:	J	Z	j	z	
B	VT	ESC	+	;	K	[k	{
C	FF	,	<	L	\	l	!	;
D	CR	-	=	M]	m	}	~
E	S	O	.	>	N	^	n	
F	SI	/	?	0	_	0		

Characters available with the ESC (^) command

To print the characters in the table below, first send the ESC (^) command.

CODE	0	1	7
0			▶
1	⊕	◀	
2	⊙	⋈	
3	♥	!!	
4	♠	⌘	
5	♣		
6	♠	_	
7	•	±	
8	■	↑	↓
9	○		
A	⊗	→	
B	♂	←	
C	♀	↳	
D	♪	↗	
E	♫	↖	
F	⊙	▼	◊

International character sets

You can select one of the following international character sets with the default-settings mode or the ESC R command. For example, when you select “Italic France,” the characters in the “France” row on the table below are used in the italic character table.

The following eight international character sets can be selected with the default-settings mode or with the ESC R command.

Country	ASCII code hex											
	23	24	40	5B	5C	5D	5E	60	7B	7C	7D	7E
USA	#	\$	@	[\]	^	'	{		}	~
France	#	\$	à	°	ç	§	^	'	é	ù	è	¨
Germany	#	\$	§	Ä	Ö	Ü	^	'	ä	ö	ü	ß
UK	£	\$	@	[\]	^	'	{		}	~
Denmark	#	\$	@	Æ	Ø	Å	^	'	æ	ø	å	~
Sweden	#	¤	É	Ä	Ö	Å	Ü	é	ä	ö	å	ü
Italy	#	\$	@	°	\	é	^	ù	à	ò	è	ì
Spain	Pt	\$	@	;	Ñ	¿	^	'	¨	ñ	}	~

The following five additional sets are available only with the ESC R command.

country	ASCII code hex											
	23	24	40	5B	5C	5D	5E	60	7B	7C	7D	7E
Japan	#	\$	@	[¥]	^	'	{		}	~
Norway	#	¤	É	Æ	Ø	Å	Ü	é	æ	ø	å	ü
Denmark II	#	\$	É	Æ	Ø	Å	Ü	é	æ	ø	å	ü
Spain II	#	\$	á	;	Ñ	¿	é	'	í	ñ	ó	ú
Latin America	#	\$	á	;	Ñ	¿	é	ü	í	ñ	ó	ú
Korea	#	\$	@	[₩]	^	'	{		}	~
Legal	#	\$	§	°	'	¨	π	'	©	®	†	™

Glossary

The following definitions apply specifically to printers. If a word is *italicized*, see **that** topic for more information.

ASCII

American Standard Code for Information Interchange. A standardized coding system for assigning numerical codes to letters and symbols.

auto *line feed*

When this feature is selected in the default-setting mode, each carriage-return code (CR) is automatically followed by a line-feed (LF) code.

bidirectional printing

Printing in which the print head prints in both directions. This increases the speed of printing.

bit

A binary digit (0 or 1), which is the smallest unit of information used by a printer or computer.

buffer

The portion of the printer's memory used to store data before printing it.

byte

A unit of information consisting of eight bits.

characters per inch (*cpi*)

A measure of the size of text characters, sometimes referred to as pitch.

*character*tab/e

A collection of letters, numbers, and symbols that provides you with the characters used in a particular language.

condensed printing

Printing in which the width of each character is approximately 60% of the width of standard characters. Useful for fitting wide tables or spreadsheets onto **the** paper.

control code

Special codes used to control printer functions such as performing a carriage return or line feed.

cpi

See *characters per inch*.

default

A value or setting that takes effect when the equipment is turned on, reset, or initialized.

dot matrix

A method of printing in which each letter or symbol is formed by a pattern (matrix) of individual dots.

double-height printing

Printing in which each character is twice as tall as normal.

double-strike printing

Printing in which each character is printed twice.

double-width printing

Printing in which each character is twice as wide as normal.

emphasized printing

Printing in which each character is printed **twice** (darker), with the second slightly to the right of the first.

ESC/P

Abbreviation for Epson Standard Code for Printers. This system of commands gives you software control of your printer from your computer. It is standard for all Epson printers and supported by most application software for personal computers.

ESC/P 2

The enhanced version of the ESC/P printer command language. Commands in this language produce laser-like features, such as scalable fonts and enhanced graphics printing.

font

A font is a style of type designated by a family name.

hex dump

A troubleshooting feature that helps advanced users find the cause of communication problems between the printer and the computer. When the printer is in hex dump mode, it prints each code it receives in hexadecimal notation and ASCII characters. Also called data dump.

initialization

Returns the printer to its defaults (fixed set of conditions).

ink jet

A method of printing in which each letter or symbol is formed by spraying ink onto paper.

interface

The connection between the computer and the printer. A parallel interface transmits data one character or code at a time.

italic

A typestyle in which the characters slant. *This sentence is italicized.*

line feed

A control code that advances the paper one line space.

loading position

The position to which the paper is automatically loaded.

LQ printing

One of two print qualities available on your printer. LQ printing provides better readability and appearance at a reduced print speed.

parallel interface

See *interface*.

printable area

The area of a page on which the printer can print. It is smaller than the physical size of the page due to margins.

proportional printing

Printing in which the width of the character varies from character to character. For example, a capital W receives much more space than a lowercase i. The result looks more like a typeset book than a typewritten draft.

RAM

Random Access Memory. The portion of the printer's memory used as a buffer and for storing user-defined characters. All data stored in RAM is lost when the printer is **turned** off.

reset

To return a printer to its defaults either by sending a command, an INIT signal, or by **turning** the printer off and then back on.

ROM

Read Only Memory. A portion of memory that can only be read and cannot be used for data storage. ROM retains its contents when you **turn** off the printer.

self test

A method for checking the operation of the printer. When you run the self test, the printer prints the characters stored in its ROM.

software program

A software program that helps you carry out a particular task, such as word processing or financial planning.

superscript

Printing in which each character is printed at about two-thirds the normal height in the upper part of the character space.

unidirectional printing

Printing in which the print head prints in one direction only. Unidirectional printing is useful for printing graphics because it allows more precise vertical alignment than bidirectional printing.

user-defined characters

Characters that are defined and stored in the printer by the user. Also called download characters.

Index

Command descriptions are not indexed here. For information on a specific command, see the Appendix.

A

Access panel, 3-11 – 12
Adjusting loading position, 2-9 – 10
Adjusting print position, 2-10
Alt button, 1-10 1-12, 2-8, 2-15
ASCII codes, A-13 – 21
Auto line feed, 2-13 – 14, 2-16 – 17
Auto print direction, 2-13 – 14,
2-16 – 17

B

Back panel, see Access panel
Bidirectional printing, 2-14
Buffer, A-2
Buttons, 2-7 – 8, 2-15 – 16
 Alt, 1-10 1-12, 2-8, 2-15
 Alt + Economy, 2-8 – 10
 Alt + Font, 2-8 – 10
 Alt + Load/Eject, A-11
 Alt + Pause, 1-9
 Condensed, 2-7, 2-12, 2-15
 Economy, 2-7, 2-12, 2-15
 Font, 1-15, 2-7, 2-11, 2-15 – 17
 Load/Eject, 1-15, 1-18, 2-3
 2-5, 2-7
 Pause, 1-9, 1-15, 2-7, 3-2

C

Cable,
 parallel interface, 1-15 – 16
Cartridge, ink, see Ink cartridge
Character
 fonts, 2-7, 2-11 – 12, A-3
 tables, 2-13 – 14, 2-16 – 17, A-3,
 A-21 – 26

Character sets, international, A-19,
 A-29
Choosing paper, 1-3 – 4, A-3 – 4
Cleaning the print head, 3-3
Cleaning the printer, 3-4
Codes
 ASCII, A-13 – 21
 command summary, A-13 – 21
 commands, sending, A-13
 control, A-13 – 21
Computer,
 connecting to, 1-15 – 16
Condensed button, 2-7, 2-12, 2-15
Condensed light, 2-6, 2-12
Condensed printing, 2-12
Configuration, see Software
Connecting the printer, 1-15 – 16
Control codes, A-13 – 21
Control panel, 2-6 – 8, 2-13 – 18
Courier, font, 2-11, A-3
Cover
 paper feeder, 1-13
 printer, 1-10

D

Data light, 2-7, 2-16
Default
 settings, 2-13 – 18, A-12
 settings mode, 2-13 – 18

E

Economy button, 2-7, 2-12, 2-15
Economy light, 2-6
Economy printing, 2-6, 2-12
Eject button, 1-15, 1-18, 2-3, 2-5, 2-7
Ejecting paper, 1-15, 1-18

Envelopes
 loading, 2-4 - 5
 specifications, 2-2, A-4 - 5

Environment
 for printer, 1-6
 specifications, A-6 - 7

Epson Courier, 2-11, A-3
Epson Prestige, 2-11, A-3
Epson Roman, 2-11, A-3
Epson Roman T, 2-11 - 12, A-3
Epson Sans Serif, 2-11 - 12, A-3
Epson Sans Serif H, 2-11 - 12, A-3
Epson Script, 2-11, A-3
ESC/P, Intro-1, 1-17
ESC/P 2, Intro-1, 1-17, 2-12

F

Features, printer, Intro-1

Feeder, paper
 loading, 1-13 - 14
 using, 1-18

Font button, 1-15, 2-7, 2-11, 2-15 - 17
Font light, 2-6, 2-11, 2-17

Fonts
 button, 2-7, 2-11
 changing
 with control panel, 2-11
 with software programs, 2-11,
 A-15
 Epson Courier, 2-11, A-3
 Epson Prestige, 2-11, A-3
 Epson Roman, 2-11 A-3
 Epson Roman T, 2-11 - 12, A-3
 Epson Sans Serif, 2-11 - 12, A-3
 Epson Sans Serif H, 2-11 - 12, A-3
 Epson Script, 2-11, A-3
 lights, 2-6, 2-11, 2-17
 samples, 2-11
 scalable, 2-12, 2-14
 selecting, 2-1 1

Form feed, see Load/Eject button
Form length, ii

G

Graphics, 2-13 - 14, 2-16 - 17

H

Help, where to get for USA users, 2
Humidity, printer environment, A-7

I

Indicator lights, 2-6 - 7
Initialization, A-11 - 12
 default settings, A-12

Ink cartridge
 clamp, 1-10, 1-12
 installing, 1-8 - 12
 life, A-5
 precautions, 1-2 - 3
 replacing, 3-2 - 3
 specifications, A-5
 warning, 1-8, 3-3

Ink Out light, 2-7, 2-16, 3-2

Input buffer, A-2

Interface
 connecting, 1-15 - 16
 specifications, A-7 - 10

International character sets, A-19,
A-29

Italic fonts, A-26

J

Jam paper
 clearing, 3-11 - 12
 preventing, 3-12

L

Language, setting, 2-15
Lever paper-thickness, 2-4
Lights, indicator, 2-6 - 7
Lines per page, ii
Load/Eject button, 1-15, 1-18, 2-3
 2-5, 2-7

Loading paper
envelopes, 2-4 - 5
manually, 2-2 - 3
paper feeder, 1-13 - 14
single sheets, 1-13 - 14, 2-2 - 3
Loading position, adjusting, 2-9 - 10

M

Maintenance, printer, 3-2 - 4
Manual feed slot, 2-2 - 5
Manual insertion, 2-2 - 5
Micro feed
buttons, 2-8
using, 2-8 - 10
Mixed text/graphics mode, 2-13 - 14,
2-16 - 17
Moving printer, 3-4 - 5

N

Network interface mode, 2-13 - 14,
2-16 - 17

P

Page length
manual insertion, A-4
single sheets, A-4
Paper
choosing, 1-3 - 4, A-3 - 4
envelopes, 2-2, 2-4 - 5
feeder, 1-13 - 14
printable area, A-3 - 5
single sheets, 1-18, 2-2 A-3 - 4
size, 2-2, A-3 - 5
specifications, 2-2, A-3 - 5
testing, 1-4
Paper jam
clearing, 3-11 - 12
preventing, 3-11
Paper Out light, 2-7, 2-16
Paper support,
attaching, 1-5
Paper-thickness lever, 2-4

Parallel interface, 1-15, -16, A-7 - 10
Pause button, 1-8, 1-12, 1-15, 2-7,
3-2
Pause light, 2-6
Pausing printing, 1-8, 2-7, 3-2
Place for printer,
choosing, 1-6
Plugging in the printer, 1-7, 3-5 - 6
Port, printer, see Parallel interface
Power
cord, connecting, 1-7
switch, 1-7
turning on/off, 1-7 3-5 - 6
Precautions, ink jet, 1-2 - 3
Prestige, font, 2-11, A-3
Print direction, 2-13 - 14, 2-16, A-2
Print head, cleaning, 3-3
Print quality, 3-3, 3-8 - 10
Printing position, adjusting, 2-10
Print speed, A-2
Printable area, 2-13 - 14, 2-16,
A-3 - 5
Printer commands, A-13 - 21
Printer status, see Indicator lights
Printing
envelopes, 2-4 - 5
loading paper, 1-13 - 14
manual, 2-2 - 5
self test, 1-14 - 15
single sheets, ii, 2-2 - 3
tips, 1-18
Printing position, adjusting, 2-10
Problems, see Troubleshooting

Q

Quality, print, 3-3, 3-8 - 10

R

Repacking printer, 3-4 - 5
Replacing ink cartridge, 3-2 - 3
Resetting printer defaults, 2-8, A-11
Roman, font, 2-II - 12, A-3
Roman T, font, 2-II - 12, A-3

S

- Safety
 - approvals, A-7
 - information, Intro-5 – 8,
1-2-3
- Sans Serif, font, 2-II - 13, A-3
- Sans Serif H, font, 2-II - 12, A-3
- Scalable fonts, 2-12,2-14
- Script, font, 2-11, A-3
- Self test, 1-13 – 15
- Service, where to get, Intro-2
- Settings
 - changing, 2-15
 - description, 2-13
 - fonts 2-11
 - printer defaults, 2-12
- Single sheets, ii, 2-2 – 3
- Sizes, paper, 2-2, A-3 – 5
- Software
 - controlling printer with, 1-17
 - printer menu, 1-17
 - setting up, 1-17
- Specifications, A-2 – 7
- Speed, printing, A-2
- Status lights, see Indicator lights

T

- Temperature,
 - printer environment, A-6
- Testing paper, 1-4
- Testing the printer, 1-13 – 15
- Toll-free number, USA, Intro-2
- Transporting the printer, 3-4 – 5
- Troubleshooting, 3-3,3-5 – 12
 - paper handling, 3-10 – 11
 - paper jams, 3-11 – 12
 - power supply, 3-5 – 6
 - print quality, 3-3,3-8 – 10
 - printing, 3-6 – 7
- Typestyles, see Fonts

U

- Unidirectional printing, 2-14
- Unpacking the printer, 1-4

V

- Voltage, 1-7, A-6
 - caution, 1-7
 - power supply, 3-5 – 6, A-6

W

- Weight, printer, A-6
- Where USA users can get help, 2

FCC Compliance Statement

For United States Users

This equipment has been tested and found to comply with the limits for a Class B digital device, pursuant to Part 15 of the FCC Rules. These limits are designed to provide reasonable protection against harmful interference in a residential installation. This equipment generates, uses, and can radiate radio frequency energy and, if not installed and used in accordance with the instructions, may cause harmful interference to radio or television reception. However, there is no guarantee that interference will not occur in a particular installation. If this equipment does cause interference to radio and television reception, which can be determined by turning the equipment off and on, the user is encouraged to try to correct the interference by one or more of the following measures.

- Reorient or relocate the receiving antenna.
- Increase the separation between the equipment and receiver.
- Connect the equipment into an outlet on a circuit different from that to which the receiver is connected.
- Consult the dealer or an experienced radio/TV technician for help.

WARNING

The connection of a non-shielded equipment interface cable to this equipment will invalidate the FCC Certification of this device and may cause interference levels which exceed the limits established by the FCC for this equipment. It is the responsibility of the user to obtain and use a shielded equipment interface cable with this device. If this equipment has more than one interface connector, do not leave cables connected to unused interfaces. Changes or modifications not expressly approved by the manufacturer could void the user's authority to operate the equipment.

For Canadian Users

This digital apparatus does not exceed the Class B limits for radio noise emissions from digital apparatus as set out in the radio interference regulations of the Canadian Department of Communications.

Le présent **appareil numérique n'émet pas de bruits radioélectriques dépassant les limites applicables aux appareils numériques de Classe B prescrites dans le règlement sur le brouillage radioélectrique édicté par le Ministère des Communications du Canada.**

printing

l o a d i n g p a p e r

ink jet printing

normal and summary