

**EPSON®**



EQUITY 3865X/20 PLUS

U s e r s G u i d e

**EPSON®**

**EQUITY 386SX/20 PLUS  
USER'S GUIDE**

**X-EQ386-20PLUS**

## **FCC COMPLIANCE STATEMENT FOR AMERICAN USERS**

**This equipment has been tested and found to comply with the limits for a class B digital device, pursuant to Part 15 of the FCC Rules. These limits are designed to provide reasonable protection against harmful interference in a residential installation. This equipment generates, uses and can radiate radio frequency energy and, if not installed and used in accordance with the instructions, may cause harmful interference to radio or television reception. However, there is no guarantee that interference will not occur in a particular installation. If this equipment does cause interference to radio and television reception, which can be determined by turning the equipment off and on, the user is encouraged to try to correct the interference by one or more of the following measures:**

- **Reorient or relocate the receiving antenna**
- **Increase the separation between the equipment and receiver**
- **Connect the equipment into an outlet on a circuit different from that to which the receiver is connected**
- **Consult the dealer or an experienced radio/TV technician for help.**

### **WARNING**

**The connection of a non-shielded equipment interface cable to this equipment will invalidate the FCC Certification of this device and may cause interference levels which exceed the limits established by the FCC for this equipment. It is the responsibility of the user to obtain and use a shielded equipment interface cable with this device. If this equipment has more than one interface connector, do not leave cables connected to unused interfaces.**

**Changes or modifications not expressly approved by Epson America, Inc., could void the user's authority to operate the equipment.**

## **FOR CANADIAN USERS**

**This digital apparatus does not exceed the Class B limits for radio noise emissions from digital apparatus as set out in the radio interference regulations of the Canadian Department of Communications.**

**Le présent appareil numérique n'émet pas de bruits radioélectriques dépassant les limites applicables aux appareils numériques de Classe B prescrites dans le règlement sur le brouillage radioélectrique édicté par le Ministère des Communications du Canada.**

## IMPORTANT NOTICE DISCLAIMER OF WARRANTY

Epson America makes no representations or warranties, either express or implied, by or with respect to anything in this manual, and shall not be liable for any implied warranties of merchantability and fitness for a particular purpose or for any indirect, special, or consequential damages. Some states do not allow the exclusion of incidental or consequential damages, so this exclusion may not apply to you.

## COPYRIGHT NOTICE

All rights reserved. No part of this publication may be reproduced, stored in a retrieval system, or transmitted, in any form or by any means, electronic, mechanical, photocopying, recording, or otherwise, without the prior written permission of Epson America, Inc. No patent liability is assumed with respect to the use of information contained herein. While every precaution has been taken in the preparation of this publication, Epson America assumes no responsibility for errors or omissions. Nor is any liability assumed for damages resulting from the use of the information contained herein. Further, this publication and features described herein are subject to change without notice.

## TRADEMARKS

Epson is a registered trademark of Seiko Epson Corporation.

Equity is a registered trademark of Epson America, Inc.

General notice: Other product names used herein are for identification purposes only and may be trademarks of their respective companies.

# IMPORTANT SAFETY INSTRUCTIONS

1. Read all of these instructions and save them for later reference.
2. Follow all warnings and instructions marked on the product.
3. Unplug this product from the wall outlet before cleaning. Do not use liquid cleaners or aerosol cleaners. Use a damp cloth for cleaning.
4. Do not use this product near water.
5. Do not place this product on an unstable cart, stand, or table. The product may fall, causing serious damage to the product.
6. Slots and openings in the cabinet and the back or bottom are provided for ventilation; to ensure reliable operation of the product and to protect it from overheating, these openings must not be blocked or covered. The openings should never be blocked by placing the product on a bed, sofa, rug, or other similar surface. This product should never be placed near or over a radiator or heat register. This product should not be placed in a built-in installation unless proper ventilation is provided.
7. This product should be operated from the type of power source indicated on the marking label. If you are not sure of the type of power available, consult your dealer or local power company.
8. This product is equipped with a 3-wire grounding-type plug, a plug having a third (grounding) pin. This plug will only fit into a grounding-type power outlet. This is a safety feature. If you are unable to insert the plug into the outlet, contact your electrician to replace your obsolete outlet. Do not defeat the purpose of the grounding-type plug.
9. Do not locate this product where the cord will be walked on.
10. If an extension cord is used with this product, make sure that the total of the ampere ratings on the products plugged into the extension cord do not exceed the extension cord ampere rating. Also, make sure that the total of all products plugged into the wall outlet does not exceed 15 amperes.

11. Never push objects of any kind into this product through cabinet slots, as they may touch dangerous voltage points or short out parts that could result in a risk of fire or electric shock. Never spill liquid of any kind on the product.
12. Except as specifically explained in the User's Manual, do not attempt to service this product yourself. Opening or removing those covers that are marked "Do Not Remove" may expose you to dangerous voltage points or other risks. Refer all servicing in those compartments to service personnel.
13. Unplug this product from the wall outlet and refer servicing to qualified service personnel under the following conditions:
  - A. When the power cord or plug is damaged or frayed.
  - B. If liquid has been spilled into the product.
  - C. If the product has been exposed to rain or water.
  - D. If the product does not operate normally when the operating instructions are followed. Adjust only those controls that are covered by the operating instructions, since improper adjustment of other controls may result in damage and will often require extensive work by a qualified technician to restore the product to normal operation.
  - E. If the product has been dropped or the cabinet has been damaged.
  - F. If the product exhibits a distinct change in performance, indicating a need for service.

---

# ***Contents***

## **Introduction**

---

|  |   |
|--|---|
| Optional Equipment .....                   | 2 |
| Operating Systems and Other Software ..... | 3 |
| VGA Utilities .....                        | 3 |
| How to Use This Manual .....               | 4 |
| Where to Get Help .....                    | 5 |

## **Chapter 1 Setting Up Your System**

---

|  |      |
|--|------|
| 1 Choosing a Location .....                  | 1-1  |
| 2 Removing the Protector Card .....          | 1-3  |
| 3 Connecting a Monitor .....                 | 1-4  |
| Using the VGA Interface .....                | 1-4  |
| Using a Display Adapter Card .....           | 1-7  |
| 4 Connecting a Printer or Other Device ..... | 1-8  |
| Using the Parallel Interface .....           | 1-8  |
| Using the Serial Interface .....             | 1-11 |
| 5 Connecting the Keyboard .....              | 1-12 |
| 6 Connecting the Mouse .....                 | 1-13 |
| 7 Connecting the Power Cord .....            | 1-15 |
| 8 Turning On the Computer .....              | 1-16 |
| Turning Off the Computer .....               | 1-18 |

## **Chapter 2 Running the Setup Program**

---

|  |     |
|--|-----|
| Automatic Configuration .....          | 2-2 |
| Starting the Setup Program .....       | 2-2 |
| Continuing From an Error Message ..... | 2-4 |
| Moving the Cursor Block .....          | 2-5 |

|   |      |
|---|------|
| Setting the Display Adapter Type. . . . .           | 2-6  |
| Setting the Power-on Password. . . . .              | 2-9  |
| Setting the Memory Caching . . . . .                | 2-11 |
| Setting the Processor Speed . . . . .               | 2-12 |
| Setting the Keyboard and Speaker Options . . . . .  | 2-14 |
| Setting the Real-time Clock. . . . .                | 2-16 |
| Setting the Hard Disk Drive Configuration . . . . . | 2-19 |
| Hard Disk Drive Types . . . . .                     | 2-23 |
| Setting the Diskette Drive Type(s). . . . .         | 2-25 |
| Setting the Serial/Parallel Interfaces. . . . .     | 2-26 |
| Reviewing Your Settings . . . . .                   | 2-28 |
| Leaving the Setup Menu . . . . .                    | 2-30 |

### Chapter 3    **Using Your Computer**

---

|   |      |
|---|------|
| Installing MS-DOS or Another Operating System . . . . . | 3-1  |
| Copying the Reference Diskette Files. . . . .           | 3-2  |
| <b>Special Keys</b> on the Keyboard . . . . .           | 3-3  |
| Stopping a Command or Program. . . . .                  | 3-5  |
| Resetting the Computer . . . . .                        | 3-5  |
| Using a Power-on Password . . . . .                     | 3-7  |
| Changing a Power-on Password . . . . .                  | 3-8  |
| Deleting a Power-on Password . . . . .                  | 3-9  |
| Using Disks and Disk Drives . . . . .                   | 3-10 |
| How Disks Store Data . . . . .                          | 3-10 |
| Types of Diskette Drives . . . . .                      | 3-12 |
| Caring for Diskettes and Diskette Drives.. . . . .      | 3-14 |
| Write-protecting Diskettes . . . . .                    | 3-16 |
| Using a Single Diskette Drive System . . . . .          | 3-18 |
| Inserting and Removing Diskettes . . . . .              | 3-19 |
| Formatting Diskettes . . . . .                          | 3-21 |
| Making Backup Copies . . . . .                          | 3-21 |
| Using a Hard Disk Drive. . . . .                        | 3-22 |



## Chapter 4 **Enhancing System Operations**

---

|  |      |
|--|------|
| Using AUTOEXEC.BAT and Other Batch Files. .... | 4-1  |
| Changing the Processor Speed .....             | 4-2  |
| Entering Keyboard Commands. ....               | 4-4  |
| Using the ESPEED Program .....                 | 4-5  |
| Reassigning the Diskette Drives .....          | 4-7  |
| Using the AFDD Program .....                   | 4-8  |
| Using Your Computer as a Network Server .....  | 4-9  |
| Using a Password in Network Server Mode .....  | 4-10 |
| Using Expanded Memory Beyond 640KB. ....       | 4-11 |
| Using Special VGA Features.....                | 4-12 |

## Chapter 5 **Accessing Internal Components**

---

|                                 |      |
|---------------------------------|------|
| Removing the Cover .....        | 5-2  |
| Removing the Subassembly .....  | 5-5  |
| Replacing the Subassembly ..... | 5-8  |
| Replacing the Cover .....       | 5-16 |

## Chapter 6 **Installing and Removing Options**

---

|                                     |      |
|-------------------------------------|------|
| Changing the Jumper Settings .....  | 6-2  |
| Moving a Jumper.....                | 6-4  |
| Installing an Option Card .....     | 6-5  |
| Removing an Option Card .....       | 6-9  |
| Adding Memory Modules .....         | 6-10 |
| Installing Memory Modules .....     | 6-11 |
| Removing Memory Modules.....        | 6-15 |
| Installing a Math Coprocessor ..... | 6-19 |
| Removing a Math Coprocessor.....    | 6-22 |
| Post-installation Setup .....       | 6-23 |

## Chapter 7 Installing and Removing Disk Drives

---

|   |      |
|---|------|
| Using the Correct Drive Bay . . . . .                         | 7-2  |
| How to Use This Chapter . . . . .                             | 7-3  |
| Setting the Hard Disk Drive Jumpers . . . . .                 | 7-4  |
| Setting the Jumpers for Two Hard Disk Drives . . . . .        | 7-4  |
| Changing the Jumper Settings . . . . .                        | 7-5  |
| Installing a Hard Disk in the Vertical Position. . . . .      | 7-7  |
| Removing the Mounting Frames From the Drive . . . . .         | 7-8  |
| Removing and Attaching the Mounting Plate . . . . .           | 7-10 |
| Installing the Drive . . . . .                                | 7-12 |
| Attaching the Cable to the Bottom of the Subassembly. . . . . | 7-19 |
| Removing a Hard Disk From the Vertical Position . . . . .     | 7-21 |
| Installing or Removing a Disk Drive in the                    |      |
| Horizontal Position . . . . .                                 | 7-23 |
| Installing a Disk Drive in the Horizontal Position. . . . .   | 7-24 |
| Removing a Disk Drive From the Horizontal Position . . . . .  | 7-33 |

## Appendix A Troubleshooting

---

|   |      |
|---|------|
| Identifying Your System . . . . .       | A-1  |
| Error Messages . . . . .                | A-2  |
| The Computer Won't Start. . . . .       | A-5  |
| The Computer Does Not Respond . . . . . | A-6  |
| Password Problems . . . . .             | A-8  |
| Removing a Password . . . . .           | A-9  |
| Setting a New Password . . . . .        | A-11 |
| Keyboard Problems . . . . .             | A-12 |
| Monitor Problems . . . . .              | A-13 |
| Diskette Problems . . . . .             | A-15 |
| Diskette Drive Problems . . . . .       | A-18 |
| Hard Disk Problems . . . . .            | A-19 |
| Installing the Drive . . . . .          | A-20 |
| Preparing the Drive . . . . .           | A-21 |
| Accessing Data on the Drive . . . . .   | A-22 |

|                                 |      |
|---------------------------------|------|
| Software Problems .....         | A-23 |
| Printer Problems .....          | A-24 |
| Option Card Problems .....      | A-25 |
| Mouse Problems .....            | A-26 |
| Memory Module Problems .....    | A-27 |
| Math Coprocessor Problems ..... | A-27 |

## Appendix B **Physically Formatting a Hard Disk**

---

|  |      |
|--|------|
| Choosing the Type of Format .....                | B-2  |
| Reformatting a Used Disk .....                   | B-3  |
| Formatting a New Disk .....                      | B-4  |
| Selecting an Option .....                        | B-4  |
| Starting the Formatting Process .....            | B-4  |
| Option 1, Format .....                           | B-5  |
| Modifying the Defective Track Table .....        | B-7  |
| Formatting the Disk .....                        | B-9  |
| Option 2, Destructive Surface Analysis .....     | B-10 |
| Option 3, Non-destructive Surface Analysis ..... | B-12 |
| Exiting the Hard Disk Format Menu .....          | B-13 |

## Appendix C **Performing System Diagnostics**

---

|                                   |      |
|-----------------------------------|------|
| Starting System Diagnostics ..... | C-2  |
| Selecting an Option .....         | C-4  |
| Modifying the Device List .....   | C-5  |
| Selecting a Test .....            | C-6  |
| Resuming From an Error .....      | C-8  |
| Error Codes and Messages .....    | C-12 |

## Appendix D Specifications

---

|                                  |     |
|----------------------------------|-----|
| CPU and Memory .....             | D-1 |
| Controllers .....                | D-2 |
| Interfaces .....                 | D-2 |
| Power Supply .....               | D-3 |
| Mass Storage .....               | D-3 |
| Keyboard .....                   | D 4 |
| Environmental Requirements ..... | D-4 |
| Physical Characteristics .....   | D-5 |

## Glossary

---

## Index

---

---

## ***Introduction***

The Epson® Equity®' 386SX/20 PLUS is a high-performance personal computer which offers exceptional speed and convenience in a compact design. It includes 2MB of internal memory, a built-in VGA (video graphics array) display adapter, built-in parallel and serial interfaces, and an IBM®PS/2™ compatible mouse port.

The built-in interfaces allow you to connect most of your peripheral devices directly to the computer, so you do not have to install option cards. If you need to install additional devices, such as a modem or networking card, you can use the four standard option slots (three 16-bit and one 8-bit) inside the computer.

Your system can support up to three internal drives: either two diskette drives and one hard disk drive, or one diskette drive and two hard disk drives.

The Equity 3865X/20 PLUS offers several other features to enhance its speed and versatility:

- ❑ Memory caching. Portions of your system memory are copied to a high-speed cache buffer so your computer can access programs and data very quickly.
- ❑ Shadow RAM. Your system ROM (read-only memory) and video ROM are copied into the computer's RAM (random access memory) to further accelerate system performance.
- ❑ Super VGA mode. The built-in VGA adapter and VGA drivers (included) provide graphics resolutions up to 800 x 600 in 16 colors or 640 x 480 in 256 colors on compatible VGA monitors.

- ❑ Continuous Edge Graphics™ (CEG™) technology (provided by Edsun™). The built-in CEG chip refines the jagged lines of images on a CRT screen by giving a standard 640 x 480 VGA screen the effective resolution of 2048 x 2048 and boosting the palette from 256 to 750,000 colors. When used with the appropriate application software and device drivers, this technology gives you a clearer, more accurate representation of graphics and text.

---

## ***Optional Equipment***

You can easily upgrade your computer by installing additional memory and adding optional devices compatible with the IBM Personal Computer, PC XT,™ or PC AT™

By adding memory modules to the main system board, you can expand the computer's memory up to 14MB. Memory modules are efficient because your computer can access memory on modules faster than memory on an option card. Also, they eliminate the need to use an option slot to add memory to your system. If necessary, you can add additional memory to your system by using an option card to bring your total memory to 16MB.

You may also want to install the Intel®80387SX (20MHz) math coprocessor to speed up calculations in certain application programs.

Check with your authorized Epson dealer to see which options are available.

---

## ***Operating Systems and Other Software***

You may have a version of MS-DOS® to use with your computer. Epson has enhanced MS-DOS by adding two time-saving utilities-HELP and MENU-that make it easier to use. The HELP program lets you display information about any MS-DOS command on the screen. MENU provides an easy way to run many of the MS-DOS commands.

### Note

MS-DOS is not the only operating system you can use with your computer. You can run practically any operating system compatible with MS-DOS, OS/2, Unix® or XENIX®. See the documentation that came with your operating system to install and run it on your computer.

You can use virtually any application program designed for the IBM PC, PC XT, PC AT, or compatible computers on your Equity 386SX/20 PLUS. You may also use powerful software, such as Microsoft® Windows/386.

---

## ***VGA Utilities***

Epson has provided special VGA utilities and device drivers that you can use with certain standard VGA and multi-frequency monitors. With these drivers, you can use super VGA features such as 16-color graphics mode resolutions up to 800 x 600, 256-color resolutions up to 640 x 480, and 132-column text mode. See your VGA Utilities booklet for complete information.

Epson also provides special device drivers that let you take advantage of the Edsun CEG technology. These drivers instruct specific applications to recognize the extra colors and higher resolutions made available by CEG. See your CEG Utilities booklet for instructions.

---

## ***How to Use This Manual***

This manual explains how to set up and operate your computer, install options, and run diagnostics checks. The illustrations show a computer with a 5¼-inch diskette drive, but instructions for using a 3½-inch drive are also included.

### **Note**

Although this manual provides tips for using MS-DOS, it does not explain how to use an operating system. See your operating system manuals for comprehensive instructions on installing and using the operating system.

You do not need to read everything in this book; see the following chapter summaries.

Chapter 1 provides simple step-by-step instructions for setting up your system. On the back cover foldout are illustrations showing the different parts of your computer; refer to these as you set up your system.

Chapter 2 describes how to run the Setup program to define your computer's configuration. Do this before you use your computer. You may need to do it again later if you change the configuration.

Chapter 3 provides instructions for important operating procedures, such as using and caring for disks and disk drives.

Chapter 4 describes specialized features you can use to enhance your system's performance.

Chapter 5 contains instructions for removing the cover and subassembly and then replacing the subassembly and cover.

Chapter 6 describes some of the options you can use in your computer and contains instructions for setting jumpers and installing options.



Chapter 7 explains how to install and remove a hard disk or diskette drive.

Appendix A contains troubleshooting tips.

Appendix B describes how to perform a hardware-level format on a hard disk. You need to do this only if you have installed a new hard disk that has never received this low-level format, or if you are having serious problems with the disk

Appendix C outlines the system diagnostic checks. If you are having trouble with any part of the hardware, you may want to run some of these.

Appendix D gives the computer's technical specifications.

At the end of the manual, you'll find a glossary and an index.

---

## ***Where to Get Help***

Customer support and service for Epson products are provided by a network of authorized Epson dealers and Customer Care Centers throughout the United States. Epson America provides product information and support to its dealers and Customer Care Centers.

Therefore, we ask that you contact the business where you purchased your Epson product to request assistance. If the people there do not have the answer to your question, they can obtain it through our toll-free dealer support program. Epson is confident that this policy will provide you with the assistance you need.

Call the Epson Consumer Information Center at (213) 782-2600 for the the location of your nearest Epson dealer or the nearest Customer Care Center. To locate or purchase accessories or supplies, contact your nearest Epson dealer.

## ***Setting Up Your System***

Setting up your Equity 386SX/20 PLUS personal computer is easy. Just follow the eight steps in this chapter. As you set up your computer, you may want to leave this manual's back cover foldout open so you can refer to the illustrations identifying the different parts.

### Note

The illustrations in this manual show the computer with a **5<sup>1</sup>/<sub>4</sub>-inch** diskette drive. If your system has a **3<sup>1</sup>/<sub>2</sub>-inch** diskette drive instead, and you need additional instructions, see Chapter 3.

## **1** ***Choosing a Location***

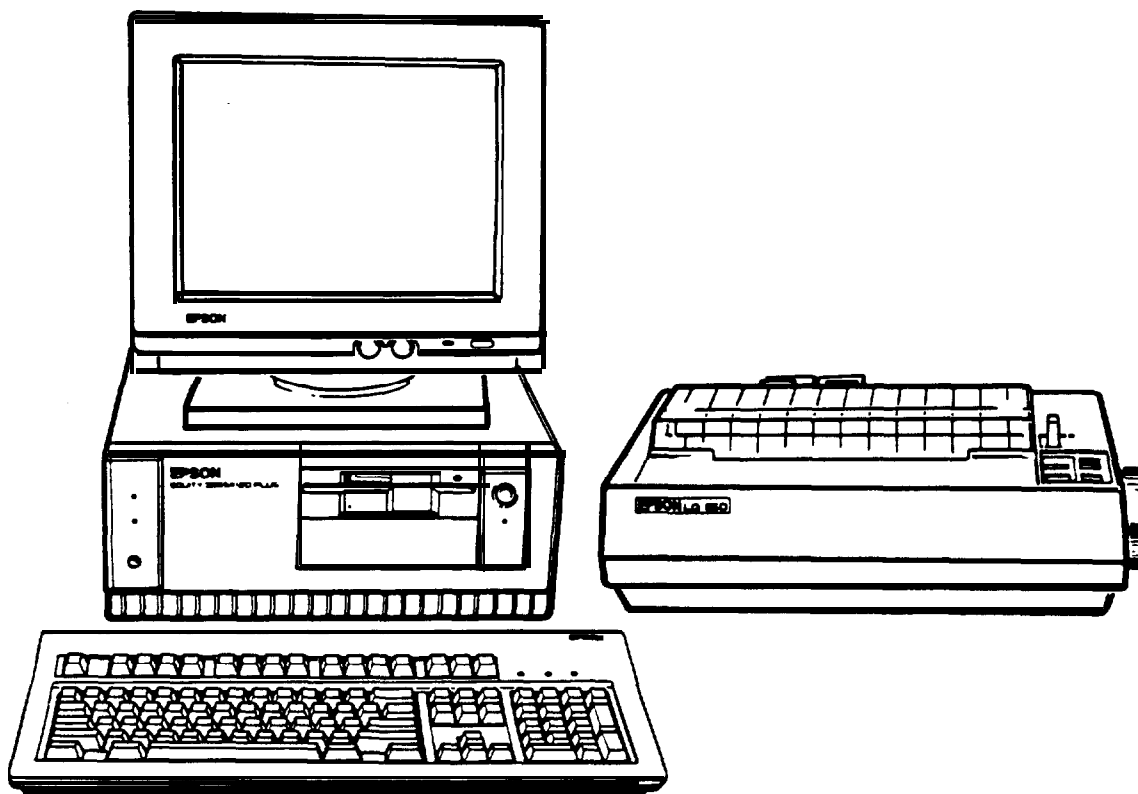

Before you set up your computer, it's important to choose a safe, convenient location that provides the following:

- ❑ A large, sturdy surface. The desk or table should be strong enough to support the weight of your system and all of its components. Select a location that allows plenty of space so you can work comfortably.
- ❑ A flat, hard surface. Soft surfaces like beds and carpeted floors attract static electricity, which can erase data on your disks and damage the computer's circuitry. Soft surfaces also prevent proper ventilation.
- ❑ Good air circulation. Air must be able to move freely under the system and behind it. Leave several inches of space around the computer.
- ❑ Moderate environmental conditions. Protect your computer from extremes in temperature, humidity, dust, and smoke. Avoid direct sunlight or any other source of heat. High humidity also hinders operation, so select a cool, dry area.
- ❑ Appropriate power sources. To prevent static charges, connect all your equipment to 120-volt grounded outlets. You need one outlet for the computer, one for the monitor, and additional outlets for a printer and any other peripherals.
- ❑ No electromagnetic interference. Locate your system away from any electrical device, such as a telephone, which generates an electromagnetic field.

## 2 *Removing the Protector Card*

If you have a 5 <sup>1</sup>/<sub>4</sub>-inch diskette drive, there is a protector card in the diskette slot. This card is inserted at the factory to protect the read/write heads in the drive. To remove it, flip the latch up to pop the card out part way, then pull it out, as shown below.

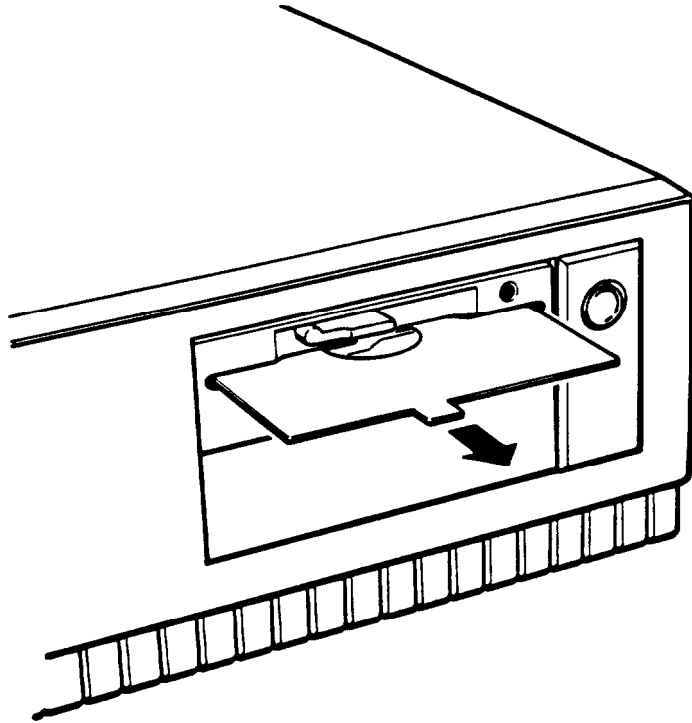

(If you have a second 5 <sup>1</sup>/<sub>4</sub>-inch diskette drive, be sure to remove the protector card from that drive as well.)

Save the protector card. If you transport your computer, you may want to insert the card into your diskette drive prior to shipping. This will protect the read/write heads during transportation.

# 3 Connecting a Monitor

The procedure you use to connect your monitor to the computer depends on the type of monitor you have. If you have a VGA monitor (or a multi-frequency monitor with an analog connector), you can connect it to the computer's built-in VGA port. See "Using the VGA Interface" below. If you have any other type of monitor, see "Using a Display Adapter Card" below.

## *Using the VGA Interface*

Follow these steps to connect your VGA monitor to the VGA port on the computer:

1. Make sure your monitor is turned off.
2. Place your monitor on top of or near the computer. For easy access, turn the monitor and computer around so the backs of both components are facing you.
3. If necessary, connect the monitor cable to the monitor. (Your monitor may have a permanently attached cable.)

4. Examine the connector end of the monitor cable, and position the plug to match the orientation of the monitor interface (marked with a monitor icon). Then insert the plug into the port (the connector should fit in easily when properly oriented), as shown below.

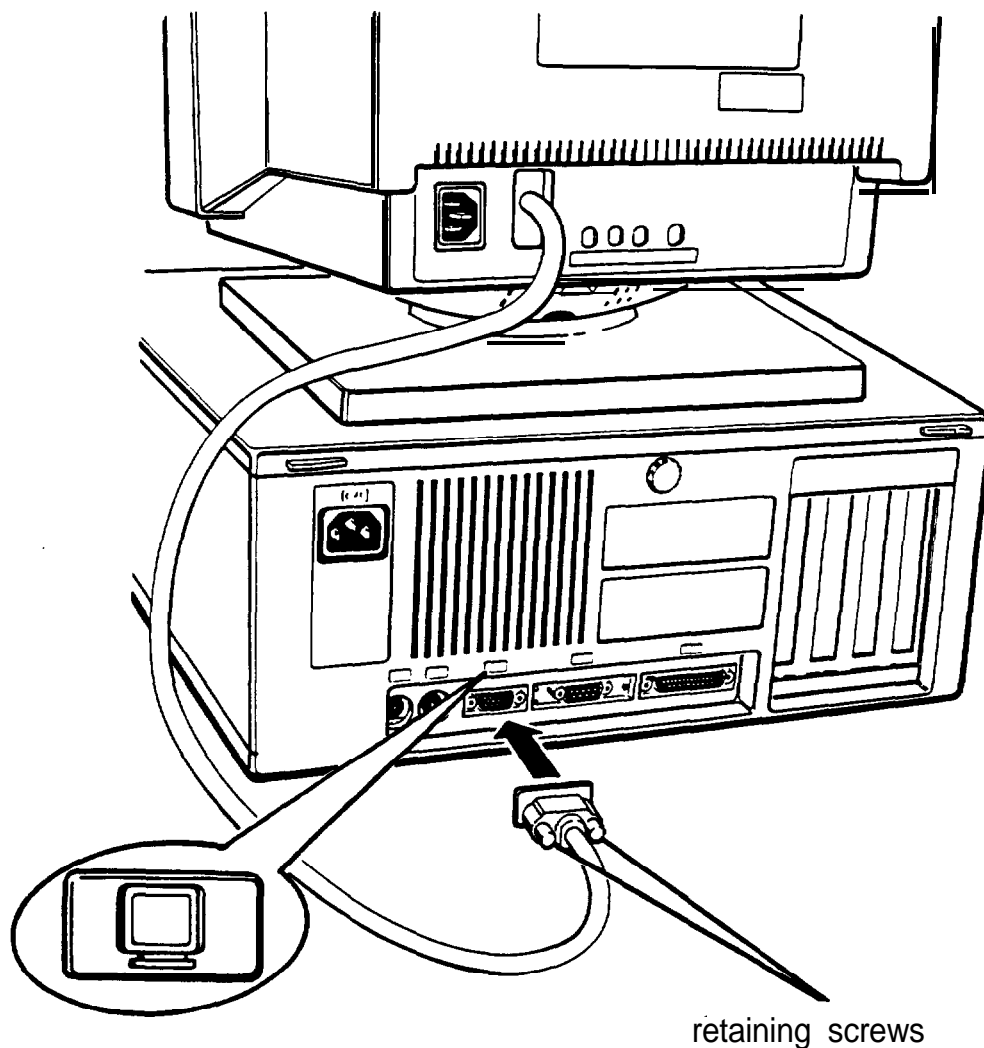

#### Caution

To avoid damaging the connector, take care not to bend the **pins** when inserting the plug.

5. If the connector has retaining screws, tighten them by hand or with a screwdriver, depending on the screw type.

6. If necessary, plug the monitor power cord into the monitor's power inlet, as shown below.

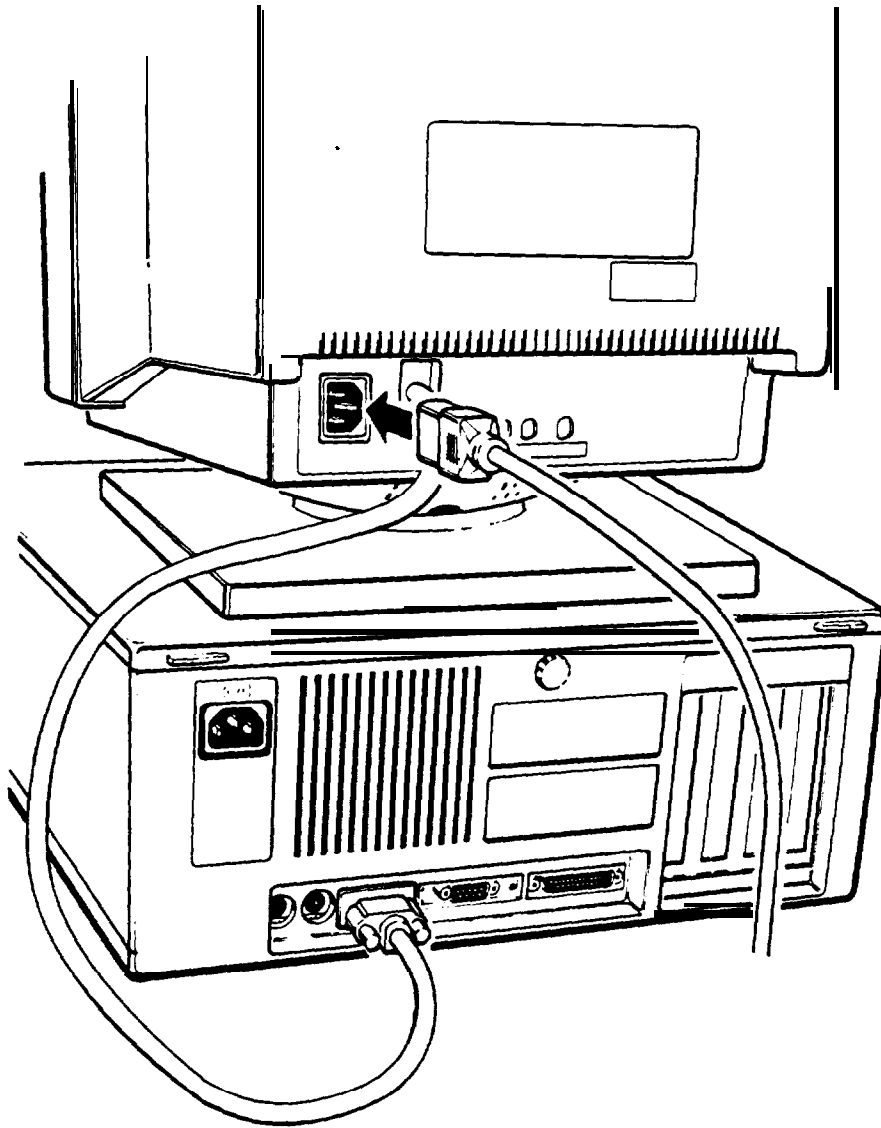

7. Plug the other end of the power cord into an electrical outlet.

## ***Using a Display Adapter Card***

If you are using a non-VGA monitor, you'll need to install a display adapter (video) card in one of the computer's option slots before you can connect the monitor. (Your dealer may have already installed the video card for you.)

If the video card has not yet been installed, you'll need to follow the instructions in Chapter 6 to install it. But first, check the following table to make sure your display adapter card and monitor are properly matched.

Monitor/video card compatibility

| Monitor      | Video card  |
|--------------|---|
| Monochrome   | Monochrome display adapter (MDA)<br>Multi-mode graphics adapter (MGA)<br>Enhanced graphics adapter (EGA)<br>Hercules® graphics card |
| Color or EGA | Color graphics adapter (CGA)<br>Multi-mode graphics adapter (MGA)<br>Enhanced graphics adapter (EGA)                                |

- CGA monitors do not support EGA modes.

When you are installing the video card, check to make sure any switches or jumpers on the card are set properly. For example, you may need to change a switch setting to select color or monochrome. See the documentation that came with your monitor or video card for instructions.



## Note

If you install an EGA or VGA display adapter card or if you install another type of card that you want to be the primary display adapter, you must set jumper J2 on the main system board to disable the built-in VGA interface.

If you install one or more cards, you also may need to set jumper J1 to tell the computer the type of monitor you are using: monochrome or color. If you have two types of cards, set the jumper to indicate which one is your primary monitor type. See Chapter 6 for instructions on changing jumper settings.

Once you have installed your video card, return to this section to connect your monitor to the computer. If your monitor came with its own manual, follow the instructions there. Otherwise, you can follow the steps in ‘Using the VGA Interface’ above; just insert your monitor connector into the video card port instead of the built-in VGA port.

## **4** *Connecting a Printer or Other Device*

Your computer has both parallel and serial interfaces. To connect a printer or other peripheral device to one of these interfaces, follow the instructions below. Of course, Epson offers a full range of printers; ask your dealer for more information.

### ***Using the Parallel Interface***

The parallel interface on your computer is Centronics® compatible and uses a DB-25S connector.

To connect your printer and computer, you need an IBM compatible printer cable. If you are not sure which one you need, check with your Epson dealer.

Once you have the correct printer cable, follow these steps:

1. Place the printer next to the computer with the back panels of both components facing you.
2. One end of the printer cable has a 25-pin, D-shell connector. Position the plug to match the orientation of the parallel interface (marked with a special icon). Then insert the connector into the port, as shown below. If the plug has retaining screws, tighten them by hand or with a screwdriver, depending on the screw type.

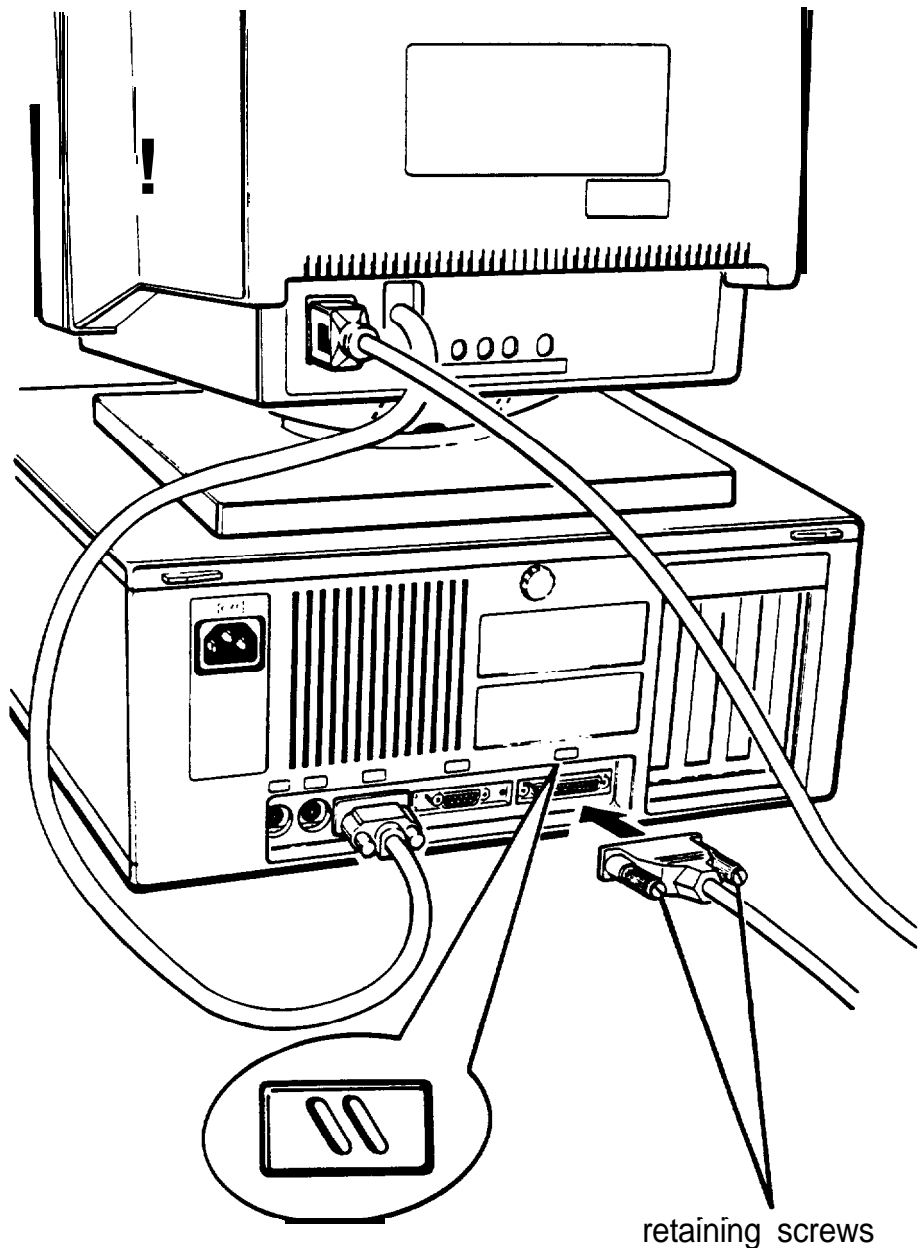

3. Connect the other end of the cable to the printer, as shown below. To secure the cable, squeeze the clips at each side of the printer port and push them into place.

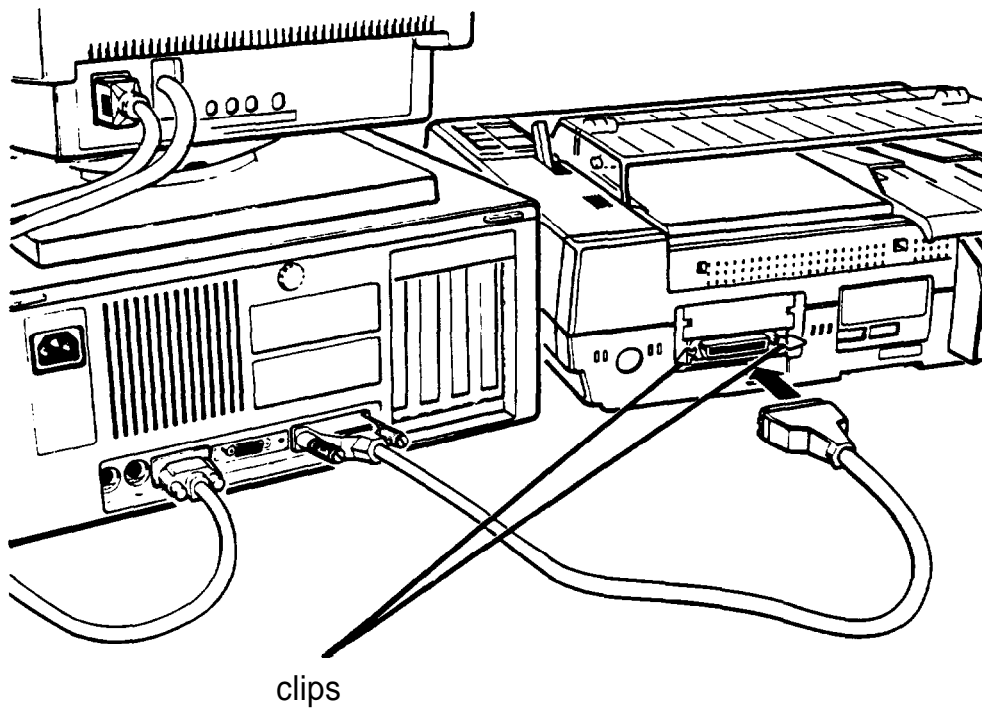

4. Plug the printer's power cord into a 120-volt, grounded electrical outlet.

## ***Using the Serial Interface***

If you have a printer, a modem, or other peripheral with a serial interface, you can connect it to the serial (RS-232C) port on the back of the computer.

The serial port uses a DB-9P connector, so be sure you have a compatible cable. To connect a serial device, follow the same steps as above for connecting a parallel device but insert the connector into the serial port, marked with a special icon, as shown below.

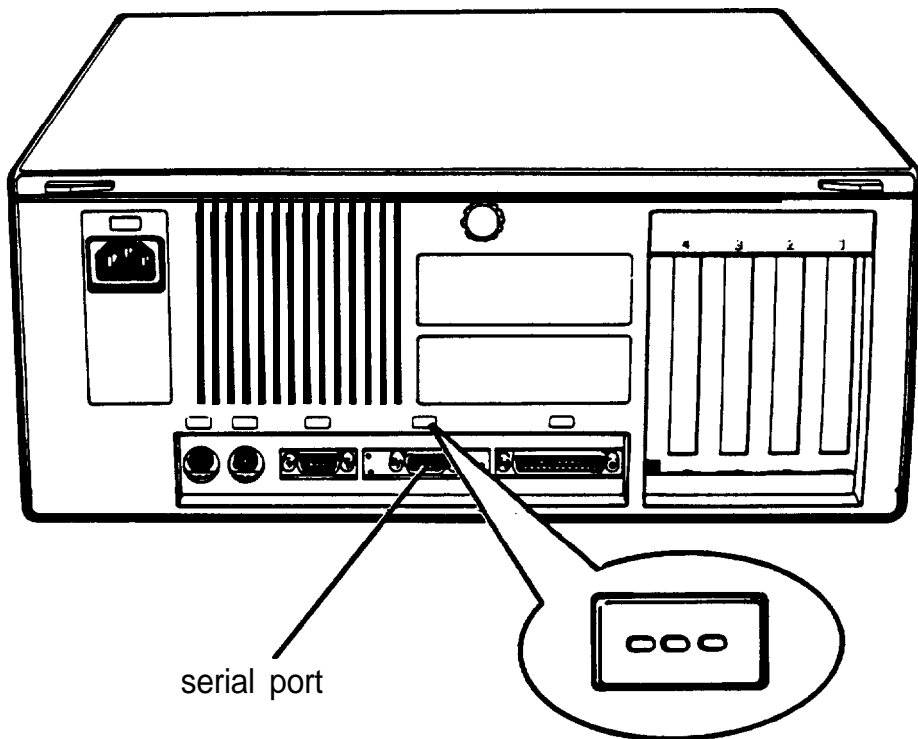

### ***Note***

You need to ensure that the serial port is set up so it functions properly. If you are using the port for a serial printer, you need to redirect printer output to the serial port instead of the parallel port. To do this, you can use the MS-DOS `MODE` or `SETMODE` command or the `MENU` utility. See your MS-DOS Reference Manual for instructions.

# 5 *Connecting the Keyboard*

Follow these steps to connect the keyboard:

1. Hold the keyboard cable connector so the arrow indicator on the housing faces up. Insert the plug into the appropriate socket, marked with a keyboard icon, as shown below.

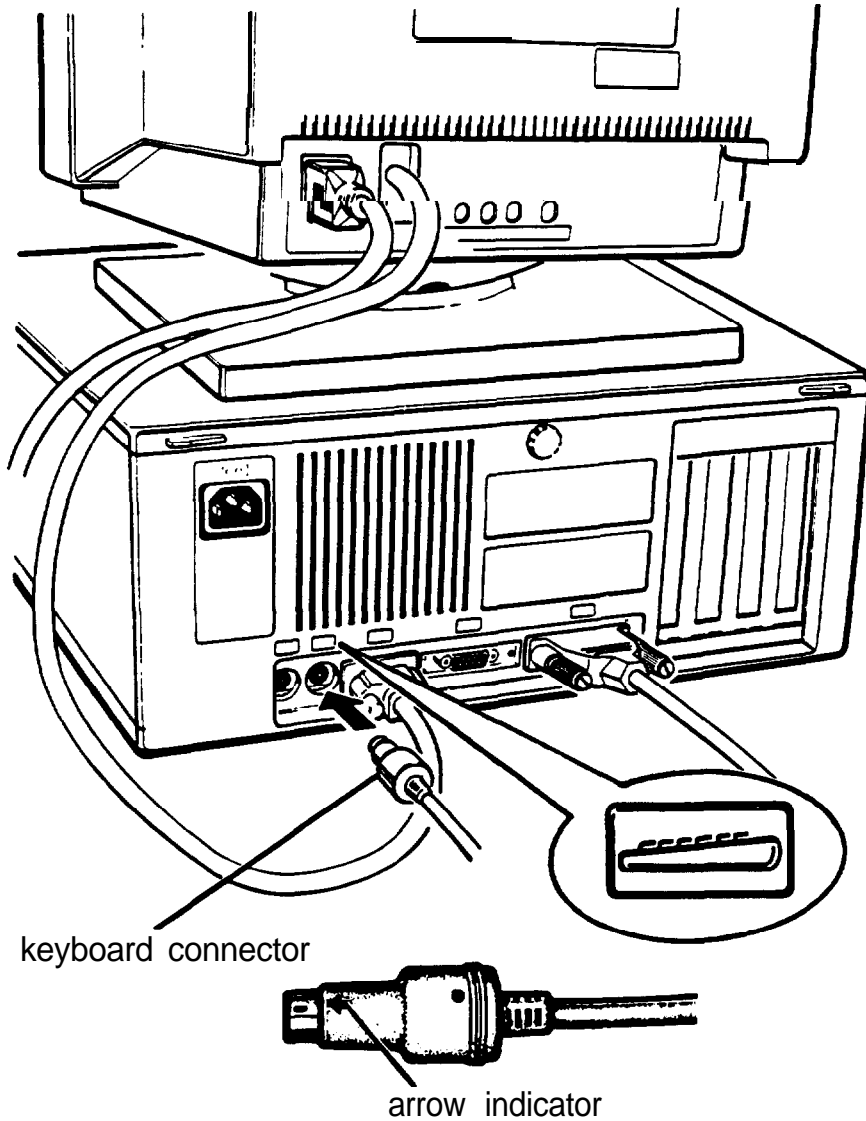

## **Caution**

Although the keyboard and mouse connectors are physically identical, they cannot be used interchangeably. Be sure to insert the keyboard plug into the keyboard socket.

2. You can raise the keyboard by adjusting the legs on the bottom. To change the angle of the keyboard, turn it over and flip each leg upward until it locks into place, as shown below.

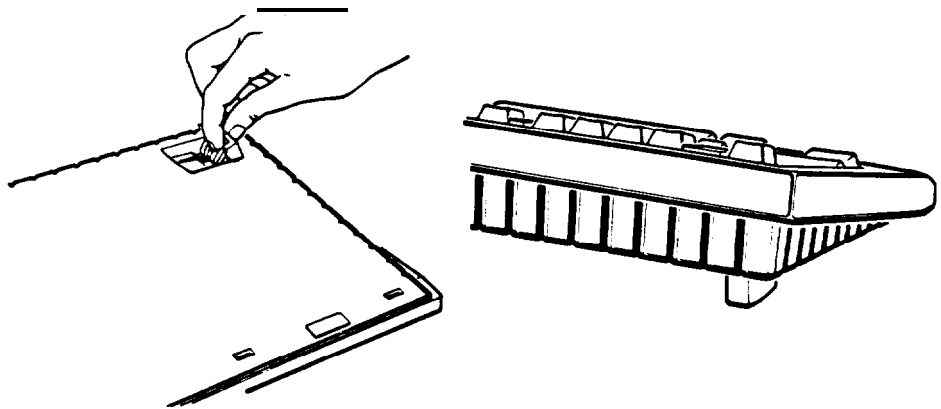

## **6** *Connecting the Mouse*

Your computer has an auxiliary port for an IBM PS/2 compatible mouse that uses a miniature DIN (6-pin) connector. If you have purchased a mouse with this type of connector (or adapter), you can connect it to the built-in port on your computer.

If you purchased a mouse with a serial connector, you can connect it to the built-in serial port on your computer.

If you have another kind of mouse that requires a different interface port, you need to install an option card to provide the interface.

To connect a mouse to the built-in mouse port, hold the mouse plug so it is oriented properly with the computer socket. Insert the plug into the appropriate socket, marked with a mouse icon, as shown in the following illustration.

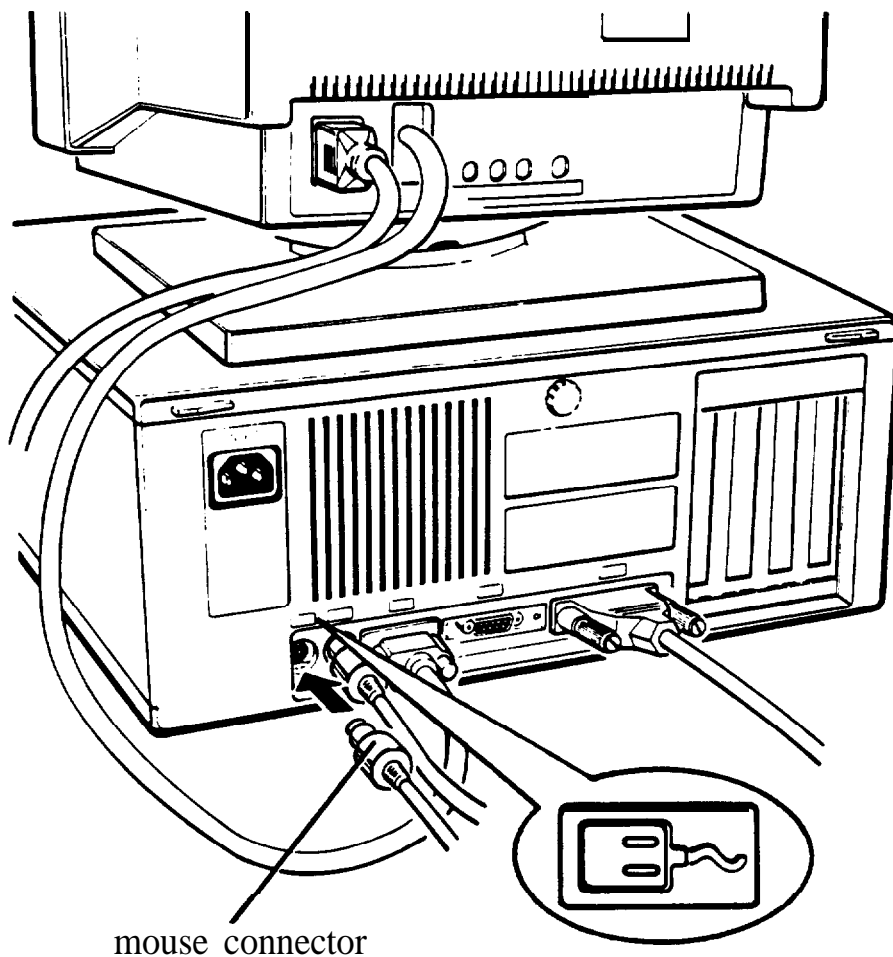

mouse connector

### **Caution**

**Although the mouse and keyboard connectors are physically identical, they cannot be used interchangeably. Be sure to insert the mouse plug into the mouse port.**

Once you have connected a mouse, you may need to add commands to your MS-DOS CONFIG.SYS and **AUTOEXEC.BAT** files to enable your computer to use a mouse. See your MS-DOS Reference Manual and the manual that came with your mouse for instructions.

# 7 *Connecting the Power Cord*

Follow these steps to connect the power cord:

1. Plug the power cord into the AC power inlet on the back panel, as shown below.

## **WARNING**

To avoid an electric shock, be sure to plug the cord into the computer before plugging it into the wall socket.

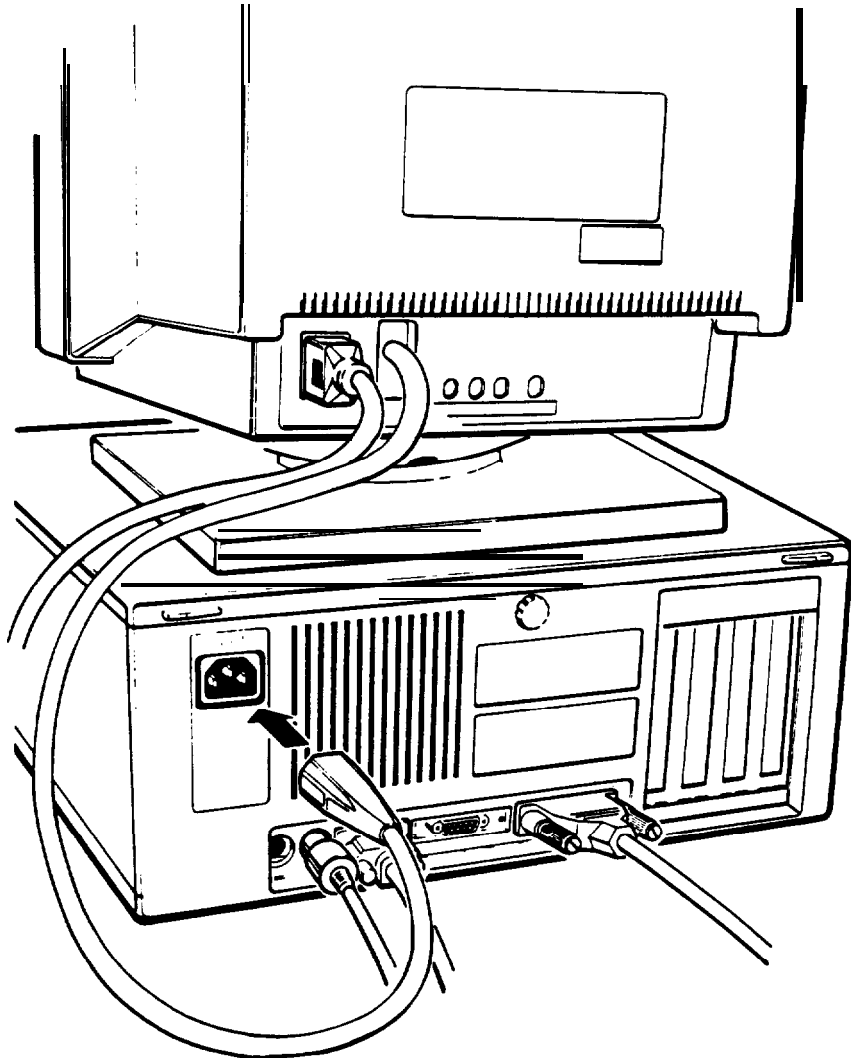

2. Plug the other end of the power cord into a 120-volt, grounded electrical outlet.



# 8 *Turning On the Computer*

After you set up your system, you're ready to turn on the power. But first, read the following safety rules to avoid accidentally damaging your computer or injuring yourself:

- ❑ Do not unplug cables from the computer when the power is on.
- ❑ Never turn on the computer with a protector card in the diskette drive.
- ❑ Never turn off or reset your computer while a disk drive light is on. This can destroy data stored on disk or make an entire disk unusable.
- ❑ Always wait at least five seconds after you turn off the power before you turn it on again. Turning the power off and on rapidly can damage the computer's circuitry.
- ❑ Do not leave a beverage on top of or next to your system or any of its components. Spilled liquid can damage the circuitry of your equipment.
- ❑ Always turn off the power, disconnect the computer's power cord, and wait five seconds before you remove the cover. Only remove the cover to access optional devices or change jumper settings.

Follow these steps to turn on your system:

1. Make sure the power cord is plugged into the AC power inlet on the back panel of the computer and into a 120-volt, grounded electrical outlet.
2. Turn your computer around so the front panel faces you and place your other system components in an arrangement that suits you. (See step 1, "Choosing a Location," for a typical arrangement.)

3. Turn on the monitor, printer, and any other peripheral devices connected to the computer.
4. To turn on the computer, press the power button located on the right side of the front panel, as shown below.

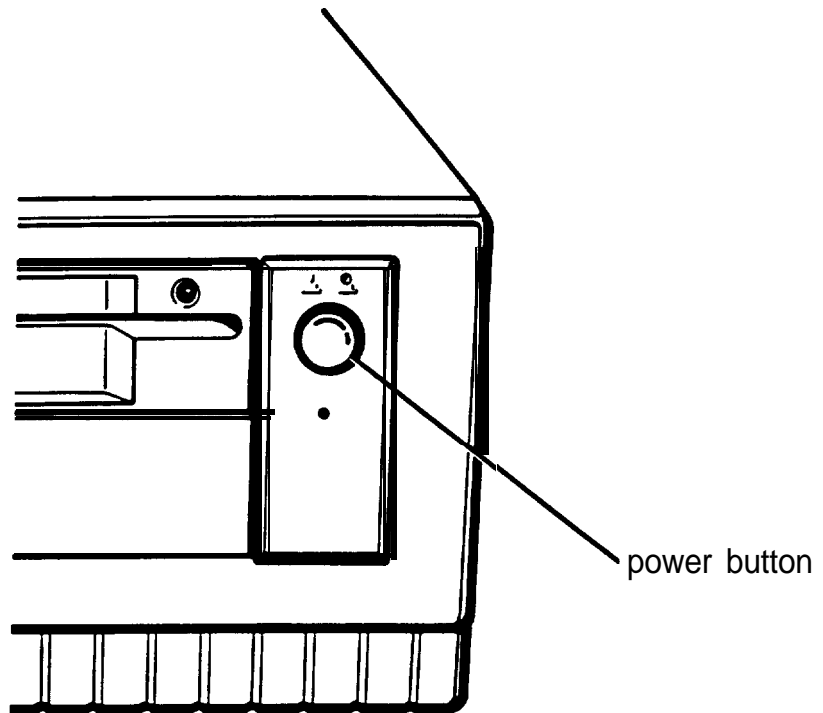

The power indicator below the button lights up. After a few seconds, the computer starts to perform a diagnostic self test—a series of checks it completes each time you turn it on to make sure everything is working correctly.

#### Note

If you or your dealer have made a major change to your system, such as adding a disk drive, you may need to wait as long as five minutes for your computer to complete power-on diagnostics the first time you turn it on. The more extensive the changes are, the longer the diagnostics take.

When the system has successfully completed its self test, you see a prompt to insert a system diskette. (Do not insert a diskette at this point.)

If necessary, use the controls on your monitor to adjust the brightness and contrast until characters on the screen are clear and at a comfortable level of intensity. If your monitor has horizontal and vertical hold controls, you may need to use them to stabilize the display.

### ***Turning Off the Computer***

When you are ready to turn off your system, reverse the sequence of steps you followed to turn it on. Turn off the computer first, then turn off the monitor and any peripherals.

Now go on to Chapter 2 and follow the instructions to run the Setup program.

### ***Running the Setup Program***

The first time you use your Equity 386SX/20 PLUS, you need to run the Setup program on the Reference diskette to define the computer's configuration. This is a simple procedure you must do at least once. (You may need to do it again later, if you change the configuration.)

The Setup program automatically configures parts of your system and lets you set (or change) the following for your computer:

- Display adapter type
- Power-on password
- Memory caching
- Processor speed
- Keyboard and speaker options
- Real-time clock's time and date
- Hard disk drive configuration
- Diskette drive type(s)
- Serial and parallel port settings.

The configuration you define with the Setup program is stored in the computer's CMOS RAM, which is backed up by a battery. Whenever you turn on the computer, it searches the CMOS RAM for the correct installation information. If the computer discovers a difference between the information in the CMOS RAM and its actual configuration, it prompts you to run the Setup program.

---

## ***Automatic Configuration***

The Equity 386SX/20 PLUS automatically defines your system's memory configuration and recognizes a math coprocessor, if you have installed one. It also detects and configures most of the devices you have installed in your system. Therefore, you may not need to change any default settings in the Setup program. However, you should check each option on the Setup menu to verify that the settings are correct for your configuration.

The computer automatically configures the 2MB of memory that comes with your system as 640KB of base memory and 1280KB of extended memory. If you install even more memory, Setup configures it as extended memory also.

---

## ***Starting the Setup Program***

Follow these steps to start the Setup program:

1. Make sure your computer is turned off.
2. Insert the Reference diskette in drive A as shown in the following illustration. Make sure the label is facing up and the read/write slot is pointed toward the drive.

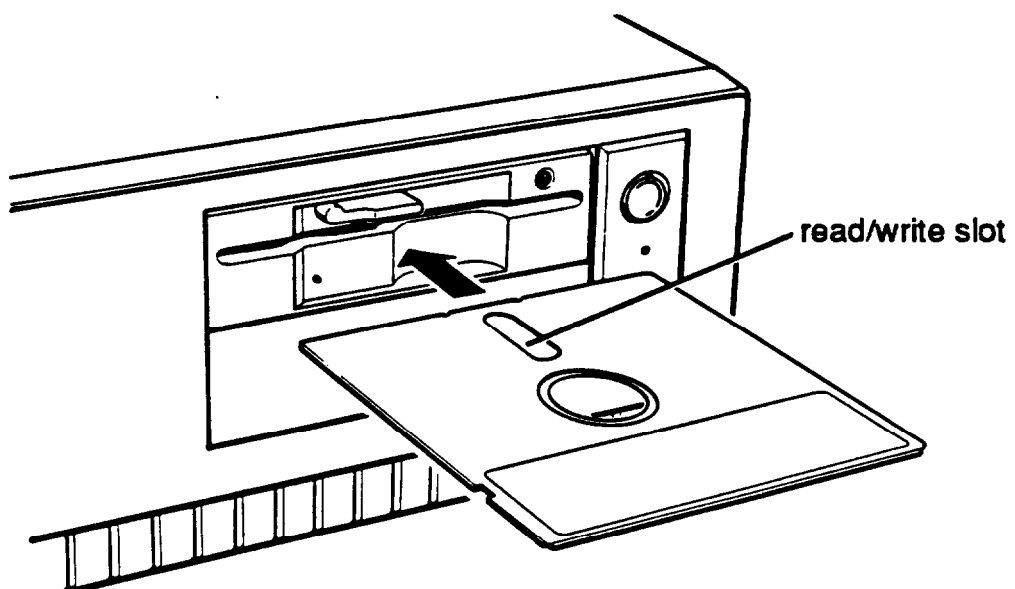

Slide the diskette into the drive until it is in all the way. Then turn the latch down to lock it in a vertical position. (For more instructions on inserting and removing diskettes, including 3 1/2-inch diskettes, see Chapter 3.)

3. Turn on your system. (Remember to turn on your monitor and any peripherals before you turn on the computer.) The screen displays the Operation Menu:

| OPERATION MENU |                                  |
|----------------|----------------------------------|
| 1              | - Setup                          |
| 2              | - <b>Format</b> hard disk        |
| 3              | - System diagnostics             |
| 4              | - Prepare hard disk for moving   |
| 0              | - Exit to DOS for more utilities |

If an error message appears when you turn on the computer, see “continuing From an Error Message,, below.

4. The Setup option is highlighted. To select it, press Enter. The screen displays the main Setup menu:

|                  |
|------------------|
| Exit             |
| Display          |
| Password         |
| Cache memory     |
| Processor speed  |
| Keyboard / Sound |
| Real-time clock  |
| Hard disk drive  |
| Diskette drive   |
| Serial/Parallel  |

## ***Continuing From an Error Message***

If your computer has never been set up, you may see an error message and prompt(s), such as the following:

```
162 - System options not set
      (Run SETUP in REFERENCE DISK)
```

```
(Resume = "F1" key)
```

If you see an error message like this one, follow these steps:

1. Press **F1**. The computer beeps and the screen displays an error message and prompt, such as the following:

```
          Error(s) detected
          ◆ Incorrect configuration

          Set default value ? ( Y / N )
```

The error message beside the diamond indicates the condition causing the error. There may be more than one error listed in the message. Here are some of the error messages you may see:

```
Time is invalid
HDD and/or HDC failed initialization
Memory size is incorrect, correction made
Cacheable range is adjusted
Incorrect configuration
Checksum is incorrect
HDD is incorrect
```

Some errors, such as `Time is invalid`, do not allow you to set a default value, so the screen does not display the `Set default value` prompt. If you see one of these errors, press `Esc`; the screen displays the main Setup menu so you can enter a new setting.

2. Be sure **Y** is highlighted and press Enter. The Setup program changes the setting that caused the error to a setting that is more likely to match your configuration. The screen displays the main Setup menu:

```
Exit
Display
Password
Cache memory
Processor speed
Keyboard / Sound
Real-time clock
Hard disk drive
Diskette drive
Serial/Parallel
```

You should check all the settings in the Setup program to make sure they are correct for your system. The default value for the setting that caused the error may not be the correct one for your configuration.

#### Note

If you choose **N** or press Esc instead of selecting **Y** to set a default value, the Setup program does not change the setting that caused the error and the screen displays the main Setup menu. Be sure to correct this setting before you exit Setup.

### ***Moving the Cursor Block***

Use ↓ and ↑ to move the cursor block (the highlighted bar) through the options on the main Setup menu. After you highlight the option you want, press Enter to select it.



## Note

If the arrow keys on the numeric keypad do not appear to work, num lock mode may be enabled (turned on). If the **Num Lock** indicator in the upper right corner of the keyboard is lit, press **Num Lock** once to turn it off and enable the arrow keys on the numeric keypad. If you need to enter numbers while using the Setup program and you want to use the numeric keypad, press **Num Lock** to turn it back on.

Follow the instructions in the rest of this chapter to use the Setup program to define your computer's configuration.

---

## ***Setting the Display Adapter Type***

The Setup program can usually detect the exact type of display adapter you are using with your computer. If you have connected a VGA monitor to the built-in VGA port, Setup automatically sets the display adapter type. (With this option you select the type of display adapter you are using—not the type of monitor.) If you have installed a display adapter card—or you just want to check the display adapter setting—follow these steps.

## Note

If you have installed an EGA or VGA display adapter card, or another type of card that you want to be the primary display adapter, you must set jumper J2 on the main system board to disable the built-in VGA interface.

If you have installed one or more video cards, you also may need to set jumper J1 to tell the computer the type of monitor you are using: either monochrome or color. If you have two types of cards, set the jumper to indicate which one is your primary monitor type. See Chapter 6 for instructions on changing jumper settings.

1. At the main Setup menu, highlight **Display**. A submenu appears identifying the current display adapter type, such as the following:

```
VGA
```

If the display adapter type is correct for your system, you can skip this section.

2. To change the display adapter setting, press **Enter**. The cursor block moves into the submenu and you see an additional menu on the right side:

```
CGA          40 column
CGA          80 column
Monochrome  80 column
EGA,MCGA,VGA or other
Remap VGABIOS at C000
```

3. Press **Enter** to move the cursor block into this submenu and then use **↑** or **↓** to highlight the option that matches your display adapter type. If you are not sure which one to choose, follow these guidelines:

- If you are using the built-in VGA adapter or have installed a VGA, EGA, or MCGA card, select **EGA,MCGA,VGA or other**.
- If you have a color graphics adapter (CGA) or a multi-mode graphics adapter (MGA) attached to an RGB (color) monitor, select **CGA 80 column**. (Also set the color/mono switch on the MGA card to color.)

- ❑ If you have a composite color monitor, such as a color television with a video input, try selecting CGA 80 Column. If the resulting resolution is poor, run Setup again and select CGA 40 column.
- ❑ If you have a monochrome display adapter (MDA), an MGA, or a Hercules MGA attached to a monochrome monitor, choose Monochrome 80 column. (Also set the color/mono switch on the MGA card to mono.)
- ❑ If you have any other combination of monitor and display adapter card, select EGA, MCGA, VGA or other. In addition, consult the documentation supplied with your display adapter card.
- ❑ If you are using IBM 3270 emulation software or Banyan 386 network software, select Remap VGABIOS at C000. To remap the VGA BIOS back to E000, rerun Setup and select EGA, MCGA, VGA or other.

#### Note

If you have two display adapters of different types, select the setting for the one you want to be your primary display adapter. The other one is your secondary adapter. A message appears at power-on telling you whether you are currently using your primary or secondary adapter.

4. After you highlight the appropriate display adapter type, press **Enter**. The screen displays your new setting.
5. Highlight **\*\*\* SAVE SETTING \*\*\*** and press **Enter** to return to the main Setup menu.

---

## ***Setting the Power-on Password***

A power-on password is a feature that lets you control who can access your system. However, you do not need to set a power-on password to use your computer. If you do not want to set a password, skip this section.

Once you set a power-on password, you must enter it at the key prompt () every time you turn on your computer or press **RESET**. If you cannot enter it correctly, the computer does not respond to your keyboard entries. Therefore, if you set a power-on password, be sure to remember it or write it down and keep it in a safe place.

If you want to use your computer as a network server, you can set your password to operate in network server mode. (See “Using Your Computer as a Network Server” in Chapter 4 for more information.)

Follow these steps to set a power-on password and turn on network server mode (if necessary):

1. At the main Setup menu, highlight **Password**. This submenu appears:

```
Power-on password
Network server mode OFF
```

2. Press **Enter**. The cursor block moves to **Power-on password**.
3. Press **Enter**. The cursor block moves to an empty box:

```
—
```

## Note

If a password already exists, this message appears:

Power-on password already installed

The Setup program does not allow you to enter a new password if you have already set one. However, you can easily change or delete the current password if you know it. See "Using a Power-on Password" in Chapter 3 for instructions.

4. To enter a password, type any combination of characters (including letters, numbers, and blank spaces) up to a total of seven characters. You can use the backspace key to delete mistakes.

Do not use characters requiring the **Shift** key, such as @, \$, or \* in your password. The computer does not recognize the **Shift** key when you use your password to access the system.

## Caution

Be sure to remember the password you enter or write it down and keep it in a safe place. If you cannot remember your password, you will not be able to access the computer the next time you turn it on.

If you want to return to the password submenu without saving any changes, press Esc.

5. After you enter a password, press **Enter** to return to the password submenu.
6. If you want to change the network server mode setting, highlight `Network server mode`. To turn network server mode on or **off**, press **Enter**.

You must set a power-on password to turn on network server mode. If you did not yet enter a password, this message appears:

Set a power-on password first

To enter a password, highlight Power-on password and follow steps 3 through 5 above.

7. After you enter a power-on password and turn network server mode on or off, highlight `**** SAVE SETTINGS ****` and press **Enter** to return to the main Setup menu.

#### Note

If you forget your password, there is a way to disable the password function. See “Password Problems” in Appendix A for instructions.

---

## ***Setting the Memory Caching***

Memory caching allows your system to work much faster. When you cache memory, the computer copies information from memory into a high-speed cache buffer. Your system can find information more quickly in the cache buffer than when it looks for it in the system memory. This greatly improves the speed at which your system performs.

#### Note

Caching is active only when your computer is operating at 20 MHz (high) speed.

The Setup program allows you to enable or disable memory caching. The default setting is enabled for all the memory currently installed in your system.

To check or change the memory cache setting, follow these steps:

1. At the main Setup menu, highlight Cache memory. The current status appears:

Cache is enabled

If your memory cache setting is correct, you can skip the rest of this section.

2. To change the setting, press **Enter**. The cursor block moves into the submenu.
3. Press **Enter** to change the Cache setting from enabled to disabled, or vice versa.
4. Highlight \* \* \* SAVE SETTING \*\* \* and press **Enter** to return to the Setup menu.

---

## ***Setting the Processor Speed***

Your computer's processor can operate at two speeds: high or low. High speed is 20 **MHz** and low speed simulates 8 MHz. The processor is set to operate at high speed (where it can access memory faster) unless you change it to low or set the speed to change automatically (when necessary).

When the computer is running at high speed, the **TURBO** indicator on the front panel is illuminated.

You should use high speed for almost everything you do since your programs work faster on high speed. However, certain application programs have specific timing requirements for diskette access and can run only at a slower speed; check your application program manual.

When you set the processor to change speed automatically, the computer switches to low whenever it needs to access a diskette drive and runs at high for all other operations.

#### Note

You may not want to use the automatic setting for certain copy-protected programs. See “Changing the Processor Speed” in Chapter 4 for more information.

This section describes how to set the processor speed in the Setup program. You can also change the speed using keyboard commands or by running the ESPEED program. See “Changing the Processor Speed” in Chapter 4 for more details.

Follow these steps to set your processor speed:

1. At the main Setup menu, highlight **Processor speed**. The current status appears:

```
Speed: High  I
```

If the displayed setting is correct, skip this section.

2. To change the processor speed, press **Enter**. The cursor moves into the submenu and you see another menu:

```
High
Automatic
Low
```

(High is 20 MHz, Low simulates 8 MHz, and Automatic tells the computer to switch from high to low when accessing a diskette drive.)

3. Press **Enter** to move the cursor block into the option menu.



4. Use ↑ or ↓ to highlight the speed you want and press **Enter**.
5. Highlight \* \* **SAVE SETTING** \*\* and press **Enter** to return to the main Setup menu.

---

## ***Setting the Keyboard and Speaker Options***

The Keyboard/Sound option lets you control these three features in your computer:

- Speaker
- Initial num lock mode
- Keyboard repeat rate.

Your computer has a built-in speaker that you can turn on or off. When the speaker is enabled (on), it beeps when you perform certain operations. Because the speaker serves a useful purpose in many applications, the default setting is enabled; however, you may prefer to disable it.

The initial num lock option in the Setup program determines whether num lock is on or off when you turn on your computer. When num lock mode is on, you can use the numeric keys on the keypad to enter numbers.

If num lock mode is on, you can turn it off by pressing **Num Lock**. The **Num Lock** light (on the keyboard) goes out and the function is disabled until you turn the computer off or until you press **Num Lock** again. The next time you turn on your computer, num lock returns to the setting you selected in the Setup program.

## Note

If you are using the keyboard that came with your computer (or another IBM AT compatible keyboard), the default for the initial num lock setting is ON. If you are using a keyboard that has 83 or 84 keys, the initial num lock default setting is OFF.

The keyboard repeat rate option lets you change the speed at which your keyboard repeats a character when you hold down a key. The default setting is Normal, but you can make the rate faster or slower.

Follow these steps to check or change the speaker and keyboard options:

1. At the main Setup menu, highlight Keyboard/Sound. The current settings appear:

|                  |         |
|------------------|---------|
| Speaker          | Enabled |
| Initial num lock | ON      |
| KB repeat rate   | Normal  |

If the displayed settings are appropriate for you, skip this section.

2. To change any of the settings, press **Enter**. The cursor block moves into the submenu and the **Speaker** option is highlighted.
3. To enable or disable the speaker (turn it on or off), press **Enter**.
4. To turn the initial num lock setting on or off, highlight **Initial num lock** and press **Enter**.

5. To change the keyboard repeat rate, highlight KB repeat rate. You see the following option menu:

|        |
|--------|
| Slow   |
| Normal |
| Fast   |

6. Press **Enter** to move the cursor block into the menu.
7. Use **↑** or **↓** to highlight the speed you want and press **Enter**.
8. Highlight \* \* \* **SAVE SETTINGS** \* \* \* and press **Enter** to return to the main Setup menu.

---

## ***Setting the Real-time Clock***

The real-time clock in your computer continuously tracks the time and date—even when the computer is turned off. The first time you run Setup, use the `Real-time clock` option to set the time and date for your computer. You may need to use this option again later to adjust your clock for daylight savings time. The computer automatically changes the date for leap years.

### Note

Another way to change the real-time clock's time and date is with the MS-DOS `TIME` and `DATE` commands. See your MS-DOS Reference Manual for instructions.

Follow these steps to set the real-time clock:

1. At the main menu, highlight Real-time clock. If the time and date have been set previously, *the* current settings appear:

|      |            |
|------|------------|
| Time | 09:16:52   |
| Date | 01-29-1991 |

If the time and date are correct, you can skip the rest of this section. If the time and date are incorrect, go to step 2 below.

If the time and date have never been set, the submenu contains a template for you to fill in:

|      |            |
|------|------------|
| Time | xx:xx:xx   |
| Date | xx-xx-xxxx |

2. Press **Enter** to move the cursor block into the submenu.
3. To set or change the time, press **Enter** again. You see this box:

|          |
|----------|
| hh:mm:ss |
|----------|

(hh stands for hours, mm stands for minutes, and s s stands for seconds.)

4. Using a 24-hour clock, enter the time in the exact format shown in the box. Type two digits for each part; the Setup program automatically inserts the colons (:). For example, to set the time to 130 p.m., you would type the following:

133000

You can use the backspace key to make corrections. When the time is correct, press **Enter**. If you enter an invalid time—for example, a number greater than 23 for the hours or greater than 59 for the minutes or seconds—the computer ignores your entry. Try again.

5. To set or change the date, highlight **Date** and press **Enter**. YOU see this box:

|                 |
|-----------------|
| mm-dd-yyyy<br>- |
|-----------------|

(mm stands for month, dd stands for day, and yyyy stands for year.)

6. Enter the date in the exact format shown in the box. Use two digits for the month and day, and four digits for the year; the Setup program automatically inserts the hyphens. For example, to set the date for January 29, 1991, you would type the following:

01291991

You can use the backspace key to make corrections. When the date is correct, press **Enter**. If you enter an invalid date—for example, a number greater than 12 for the month or greater than the number of days in that month—the computer ignores your entry. Try again.

7. Press **↑** once or twice to return to the main Setup menu.

#### Note

The Setup program automatically saves the time and date when you press **Enter** after typing each one. If you then exit the Setup program without saving your changes, the new time and date still take effect.

---

## ***Setting the Hard Disk Drive Configuration***

If your computer came with a factory-installed hard disk, your hard disk configuration has already been set and you can skip this section.

If you installed or removed a hard disk, follow these steps to set the computer's hard disk configuration:

1. At the main menu, highlight **Hard disk drive**.  
Your current settings appear, such as the following:

|          |      |    |
|----------|------|----|
| Drive 1: | Type | 60 |
| Drive 2: | None |    |

The `Type` number indicates the type of hard disk installed in your computer. See your hard disk documentation for the correct drive type number. (If that documentation does not give the drive type number, it may list the drive's parameters which you can use to identify the drive type number.) Then consult the Hard Disk Drive Types table on page 2-23 for a list of the types you can use in your computer.

The `None` after Drive 2 indicates that there is no second hard disk.

If the displayed settings match your hard disk configuration, skip the rest of this section.

If a setting is incorrect, or if you want to see more details about your hard disk configuration, go to step 2.

2. Press **Enter**. You see a menu such as the following:

| Change settings           |                        |
|---------------------------|------------------------|
| ** SAVE SETTINGS **       |                        |
| Drive 1: Type 60          | Drive 2: None          |
| Number of cylinders 776   | Number of cylinders 0  |
| Number of heads 8         | Number of heads 0      |
| Number of sectors 33      | Number of sectors 0    |
| Precomp. cylinder None    | Precomp. cylinder 0    |
| Landing zone 775          | Landing zone 0         |
| Total capacity (MB) 100.0 | Total capacity (MB) .0 |

The submenu lists the settings you can change for each drive: the number of cylinders, the number of read/write heads, the number of sectors, the precompensation cylinder, and the landing zone (the cylinder on which you park the heads when moving the computer). It also displays the total storage capacity in megabytes.

3. If you want to change the settings for drive 1 (which is drive C on most computers), press **Enter** to highlight Drive 1: . If you want to change the settings for drive 2, press **Enter** and then **→** to highlight Drive 2: .
4. Press **Enter** again. You see this submenu:

|              |
|--------------|
| None         |
| Type 60      |
| User defined |

5. If you have disconnected the drive or if the drive does not exist, highlight **None** and press **Enter**. All the drive settings become 0. Go to step 8.

If your hard disk matches one of the drive types listed in the Hard Disk Drive Types table, go to step 6.

If your hard disk does not match one of the drive types listed in the Hard Disk Drive Types table, go to step 7.

6. Highlight Type and press **Enter**. The current type number appears:

```
┌──────────────────┐
│ Type 60          │
└──────────────────┘
```

Now select the drive type number that matches your hard disk configuration in the Hard Disk Drive Types table.

You can enter the drive type in one of two ways:

- You can type the drive type number and press **Enter**. The screen displays the new number and settings.
- You can use the cursor keys to scan through the drive type numbers. This is a handy way to verify new hard disk settings before you press **Enter** because the settings list is updated as you display each new type.

After you select the appropriate drive type number, press **Enter**. The screen displays the new number and hard disk settings. Go to step 8.

7. If the configuration of the hard disk does not match one of the drive types listed in the Hard Disk Drive Types table, highlight `User de fined` and press **Enter**. You see the following:

```
┌──────────────────────────────────────────────────────────┐
│ Number of cylinders          776                          │
└──────────────────────────────────────────────────────────┘
```

The same parameter is highlighted on the submenu above. Enter the correct number of cylinders and press **Enter**.



The information for `Number of cylinders` is automatically updated on the submenu above and you see the next parameter, `Number of heads`. Enter the correct number of read/write heads for the hard disk and press **Enter**.

Follow this same procedure for each remaining item in the settings list (the number of sectors, the precompensation cylinder, and the landing zone).

If you enter a parameter incorrectly, press **↑** or **↓** to highlight the parameter and then enter it again.

The Setup program does not allow you to enter the total storage capacity; it calculates the storage capacity for you based on what you enter for the number of cylinders, heads, and sectors.

After you type the landing zone number and press **Enter**, the cursor block returns to the Drive submenu heading.

8. If you want to change the hard disk type for another drive, press **→** or **←** and return to step 4.
9. When the hard disk drive settings are correct, press **↑** to move the cursor block into the top submenu. Highlight **\*\* SAVE SETTINGS \*\*** and press **Enter** to save your hard disk drive configuration.

## Hard Disk Drive Types

The following table lists the types of hard disk drives you can use in your computer. Check this table and the documentation supplied with your hard disk to find the correct number for the type of hard disk drive(s) installed in your computer. You need to enter this number when you set the hard disk drive configuration in the Setup program.

Hard disk drive types

| Type no. | Type   | Cylinders | Heads | Sectors | Precomp | landing zone | MB    | Drive name        |
|----------|--------|-----------|-------|---------|---------|--------------|-------|-------------------|
| 00       |        |           |       |         |         |              |       | No fixed disk     |
| 01       | ST-506 | 306       | 4     | 17      | 128     | 305          | 102   | (Used by ESDI)    |
| 02       | ST-506 | 615       | 4     | 17      | 300     | 615          | 20.4  | (1)               |
| 03       | ST-506 | 615       | 6     | 17      | 300     | 615          | 30.6  |                   |
| 04       | ST-506 | 940       | 8     | 17      | 512     | 940          | 62.4  |                   |
| 05       | ST-506 | 940       | 6     | 17      | 512     | 940          | 46.8  |                   |
| 06       | ST-506 | 615       | 4     | 17      | -       | 615          | 20.4  |                   |
| 07       | ST-506 | 462       | 8     | 17      | 256     | 511          | 30.7  |                   |
| 08       | ST-506 | 733       | 5     | 17      | -       | 733          | 30.4  |                   |
| 09       | ST-506 | 900       | 15    | 17      | -       | 901          | 112.1 |                   |
| 10       | ST-506 | 820       | 3     | 17      | -       | 820          | 20.4  |                   |
| 11       | ST-506 | 855       | 5     | 17      | -       | 855          | 35.5  |                   |
| 12       | ST-506 | 855       | 7     | 17      | -       | 855          | 49.7  |                   |
| 13       | ST-506 | 306       | 8     | 17      | 128     | 319          | 20.3  |                   |
| 14       | ST-506 | 733       | 7     | 17      | -       | 733          | 42.6  |                   |
| 15       |        |           |       |         |         |              |       | -reserved-        |
| 16       | ST-506 | 612       | 4     | 17      | 0       | 663          | 20.3  |                   |
| 17       | ST-506 | 977       | 5     | 17      | 300     | 977          | 40.5  | CDC 94205-51(2)   |
| 18       | ST-506 | 977       | 7     | 17      | -       | 977          | 56.8  |                   |
| 19       | ST-506 | 1024      | 7     | 17      | 512     | 1023         | 59.5  |                   |
| 20       | ST-506 | 733       | 5     | 17      | 300     | 732          | 30.4  | Toshi baMK- 133FA |
| 21       | ST-506 | 733       | 7     | 17      | 300     | 732          | 42.6  | Toshi baMK- 134FA |
| 22       | ST-506 | 733       | 5     | 17      | 300     | 733          | 30.4  |                   |
| 23       | ST-506 | 306       | 4     | 17      | 0       | 336          | 102   |                   |
| 24       | ST-506 | 612       | 4     | 17      | 305     | 663          | 20.4  |                   |
| 25       | ST-506 | 306       | 4     | 17      | -       | 340          | 10.2  |                   |
| 26       | ST-506 | 612       | 4     | 17      | -       | 670          | 20.4  |                   |
| 27       | ST-506 | 698       | 7     | 17      | 300     | 732          | 40.6  |                   |
| 28       | ST-506 | 976       | 5     | 17      | 488     | 977          | 40.5  |                   |
| 29       | ST-506 | 306       | 4     | 17      | 0       | 340          | 10.2  |                   |

## Hard disk drive types (continued)

| Type no.     | Type   | Cylinders | Heads | Sectors | Precomp | Landing zone | MB    | Drive name            |
|--------------|--------|-----------|-------|---------|---------|--------------|-------|-----------------------|
| 30           | ST-506 | 611       | 4     | 17      | 306     | 663          | 20.4  |                       |
| 31           | ST-506 | 732       | 7     | 17      | 300     | 732          | 42.6  |                       |
| 32           | ST-506 | 1023      | 5     | 17      | -       | 1023         | 42.5  |                       |
| <b>33-40</b> |        |           |       |         |         |              |       | none                  |
| 41           | ESDI   | 1022      | 5     | 34      | -       | 1022         | 84.8  | CDC94216-106(3)       |
| 42           | ESDI   | 1022      | 5     | 36      | -       | 1022         | 89.8  | CDC94216-106          |
| 43           | ST-506 | 1024      | 8     | 17      | 512     | 1023         | 68.0  | (4)                   |
| 44           | ESDI   | 828       | 10    | 34      | -       | 828          | 137.5 | Toshiba MK-156F       |
| 45           | ST-506 | 1024      | 5     | 17      | 512     | 1023         | 42.5  | (5)                   |
| 46           | ST-506 | 615       | 8     | 17      | 128     | 618          | 40.8  | NEC D5147H .          |
| 47           |        |           |       |         |         |              |       | none                  |
| 48           | ST-506 | 820       | 6     | 17      | -       | 820          | 40.8  | Seagate ST251         |
| 49           | ST-506 | 830       | 10    | 17      | -       | 830          | 68.9  | Toshiba MK56FB        |
| 50           | ST-506 | 1024      | 9     | 17      | -       | 1023         | 76.5  | Seagate ST4096        |
| 51           | ESDI   | 828       | 7     | 34      | -       | 828          | 96.2  | Toshiba MK-154F       |
| 52           | ESDI   | 967       | 5     | 36      | -       | 967          | 85.0  | CDC94166-101          |
| 53           | ESDI   | 967       | 7     | 36      | -       | 967          | 119.0 | CDC94166-141          |
| 54           | ESDI   | 967       | 9     | 36      | -       | 967          | 153.0 | CDC94166-182          |
| 55           | ESDI   | 1022      | 7     | 34      | -       | 1022         | 118.8 | Micropolis1354A       |
| 56           | ESDI   | 967       | 5     | 34      | -       | 967          | 80.3  | CDC 94166-101(3)      |
| 57           | ESDI   | 967       | 7     | 34      | -       | 967          | 112.4 | CDC 94166-141 (3)     |
| 58           | ESDI   | 967       | 9     | 34      | -       | 967          | 144.5 | CDC94166-182(3)       |
| 59           | AT     | 980       | 5     | 17      | -       | 979          | 40.7  | Conner CP-344         |
| 60           | AT     | 776       | 8     | 33      | -       | 775          | 100   | Conner CP-3104        |
| 61           | AT     | 745       | 4     | 28      |         | 744          | 40.5  | Mini8051A native mode |
| 62           | AT     | 965       | 5     | 17      | -       | Auto         | 40    | Quantum 40AT(6)       |
| 63           | AT     | 965       | 10    | 17      | -       | Auto         | 80    | Quantum pro 80AT(6)   |
| 64-255       |        |           |       |         |         |              |       | none                  |

### Notes

1. Miniscribe 8425F, Seagate ST125
2. Conner CP-3044 or Miniscribe 8051A can be used as type 17
3. For Western Digital ESDI HDC or Drive Maker default setting
4. Micropolis 1325, Ataal 3085, Lanstor Lan64, Maxtor XT1085, Newbury NDR1085
5. **Micropolis 1323A, Miniscribe 3035, Microscience HH1050, Seagate ST4053**
6. The landing zone value is 964

The factory-installed hard disk drive type for the Equity 386SX/20 PLUS is number 60(100MB).

---

## ***Setting the Diskette Drive Type(s)***

Your Equity 386SX/20 PLUS probably came with one factory-installed diskette drive. If you added a second diskette drive or removed one, you may need to change the diskette drive settings to match your configuration. If you haven't made any changes, you can verify your drive type settings. Follow these steps:

1. At the main menu, highlight **Diskette drive**. The current settings appear:

|          |        |
|----------|--------|
| Drive A: | 1.2 MB |
| Drive B: | None   |

If the diskette drive types on the screen match your diskette drive configuration, you can skip the rest of this section.

2. To change a setting, press **Enter**. The cursor block moves into the diskette drive submenu and you see the following:

|                      |
|----------------------|
| Not installed        |
| 360 KB drive         |
| 720 KB drive (3.5")  |
| 1.2 MB drive         |
| 1.44 MB drive (3.5") |

You also see the message **Selected drive light is ON**. This tells you that the light on the diskette drive currently selected is on.

3. If you want to change the drive A settings, be sure **Drive A:** is highlighted and press **Enter**. If you want to change the drive B settings, highlight **Drive B :** and press **Enter**. The cursor block moves into the submenu.

4. Use ↓ or ↑ to highlight the correct capacity for your diskette drive and press **Enter**. The screen displays the type you selected.

If you want to enter the type for another diskette drive, return to step 3.

5. When the diskette drive settings are correct, highlight **\*\* SAVE SETTINGS \*\*** and press **Enter**. The cursor block returns to the main Setup menu and you see the updated information for drives A and B.

---

## ***Setting the Serial/Parallel Interfaces***

The serial and parallel interfaces in your computer are set to act as the primary ports. If you have not added an additional serial or parallel port, you can skip this section.

If you install an option card with its own serial or parallel port, you may want to designate the built-in port as secondary and the additional port as primary. The Setup program lets you choose which port is primary and which is secondary so there is no conflict between the built-in port and the additional port. Here are some guidelines:

- If you install an option card with a port pre-set as primary by the manufacturer, you must designate it as the primary port and make the computer's built-in port the secondary port.
- If you install an option card or peripheral with a port that is not pre-set, you can designate it as the primary or secondary port.
- If you install two option cards with ports, designate one as the primary port and the other as the secondary port and disable the built-in port.

Follow these steps to change your built-in serial and parallel interface settings:

1. At the main menu, highlight **Serial/Parallel**. The current settings for each port appear:

|          |         |
|----------|---------|
| Serial   | Primary |
| Parallel | Primary |

2. Press **Enter** to move the cursor block into the submenu. You see this additional option menu:

|           |
|-----------|
| Disabled  |
| Primary   |
| Secondary |

3. If you want to change the serial port setting, be sure **Serial** is highlighted and press **Enter**. If you want to change the parallel port setting, highlight **Parallel** and press **Enter**. The cursor block moves into the submenu.
4. Use **↓** or **↑** to highlight the appropriate setting for the port you selected and press **Enter**. The screen displays the new setting.

#### Note

If you add an option card with a parallel or serial port and highlight a setting that causes a conflict between your built-in port and the port on the option card, you see this message:

Conflict with option card

Highlight a setting that is appropriate for your system configuration and press **Enter**.

If you want to change the setting for the other port, return to step 3.

5. When the serial and parallel port settings are correct, highlight **\*\*\* SAVE SETTINGS \*\*\*** and press **Enter**. The cursor block returns to the main Setup menu and you see your updated serial and parallel interface settings.

---

## ***Reviewing Your Settings***

When you finish using the Setup program to define your computer's configuration, use **↑** to highlight **Exit** at the main Setup menu and press **Enter**. The following Setup summary appears on the screen:

|                 |                        |                                |
|-----------------|------------------------|--------------------------------|
| Cache           |                        | enabled                        |
| Memory          | Base memory            | 640Kb                          |
|                 | Extended <b>memory</b> | 1280Kb                         |
| Password        | Power-on password      | not installed                  |
|                 | Network server mode    | OFF                            |
| Display type    | Detected VGA           | <b>EGA, MCGA, VGA</b> or other |
| Processor speed |                        | High                           |

|   |
|---|
| <p><b>Change settings</b><br/><b>Exit without saving</b><br/><b>** EXIT AND SAVE **</b></p> |
|---|

There are two more **Setup** summary screens you need to check. To display the next screen, press **PgDn**. You see the following:

|                      |          |               |
|----------------------|----------|---------------|
| Real-time clock      | Time     | 13:40:38      |
|                      | Date     | 01-29-1991    |
| Coprocessor          |          | not installed |
| Diskette drive       | Drive A: | 1.2 MB        |
|                      | Drive B: | None          |
| Speaker              |          | Enabled       |
| Initial num lock     |          | <b>ON</b>     |
| Keyboard repeat rate |          | Normal        |
| Serial               |          | Primary       |
| Parallel             |          | Primary       |

**Change settings**  
**Exit without saving**  
**\*\* EXIT AND SAVE \*\***

If you have never set the real-time clock, the entry at the top of the screen flashes to remind you to set the time and date. See “Setting the Real-time Clock,” above, for instructions.

To view the last Setup summary screen, press **PgDn**. You see your hard disk drive configuration(s):

|                     |           |                     |      |
|---------------------|-----------|---------------------|------|
| Hard disk drive     |           |                     |      |
| Drive 1:            | Type 60   | Drive 2:            | None |
| Number of cylinders | 776       | Number of cylinders | 0    |
| Number of heads     | 8         | Number of heads     | 0    |
| Number of sectors   | <b>33</b> | Number of sectors   | 0    |
| Precomp. cylinder   | None      | Precomp. cylinder   | 0    |
| Landing zone        | 775       | Landing zone        | 0    |
| Total capacity (MB) | 100.0     | Total capacity (MB) | .0   |

**Change settings**  
**Exit without saving**  
**\*\* EXIT AND SAVE \*\***



Check each Setup summary screen to see if all the information is correct. YOU can press **PgUp** to display the previous screen or **PgDn** to display the next screen. If anything is incorrect, be sure **Change settings** is highlighted and then press **Enter**. The main Setup menu appears and you can change the appropriate settings.

---

## ***Leaving the Setup Menu***

If you did not change any settings or you want to cancel the changes you made, highlight **Exit without saving** at a Setup summary screen and press **Enter**. The Operation Menu appears. (If you changed the time or date, the new setting takes effect even if you exit the Setup program without saving your changes.)

If you want to save the settings you entered, highlight **\*\* EXIT AND SAVE \*\*** and press **Enter** at a Setup summary screen. The Setup program stores the new settings and resets the computer using the new configuration. If you have set a password, you need to enter it at the key prompt. (See “Using a Power-on Password” in Chapter 3 for instructions.) The Operation. Menu appears.

If you have just run Setup for the first time, remove the Reference diskette from the drive and turn off your system. Then follow the instructions in your MS-DOS Installation Guide to install MS-DOS. (If you are using a different operating system, follow the installation instructions in that manual.)

Once you have installed MS-DOS, you should always boot the computer from the hard disk or the MS-DOS Startup diskette when you are finished running Setup. First remove the Reference diskette from drive A. If you do not have a hard disk, insert the Startup diskette. Then reset your computer to make sure it performs all the commands in the CONFIG.SYS and AUTOEXEC.BAT files.

If the computer displays an error message while it is starting up, run the Setup program again and check the setting the error message indicates. If the computer still displays an error message after you check your Setup program settings, see Appendix A or C, or ask your dealer for assistance.

*Note*

Be sure to make a backup copy of your Reference diskette after you run the Setup program and install MS-DOS. See your MS-DOS Reference Manual for instructions on how to copy diskettes.

### ***Using Your Computer***

This chapter briefly describes the following procedures for using your computer:

- Installing MS-DOS or another operating system
- Copying the Reference diskette files
- Using special keys on the keyboard
- Stopping a command or program
- Resetting the computer
- Using a power-on password
- Using disks and disk drives.

---

### ***Installing MS-DOS or Another Operating System***

After you connect the components of your system and run the Setup program, you must install the operating system on your computer. If you are installing MS-DOS, follow the instructions in your MS-DOS Installation Guide. If you are installing another operating system, see the manual that comes with it for instructions. The instructions in this manual assume that you are using MS-DOS with your computer.

#### Note

Be sure to make backup copies of your original operating system diskettes.

---

## ***Copying the Reference Diskette Files***

If you have a hard disk, you'll probably want to copy some of the files on your Reference diskette to the hard disk. This allows you to run the programs directly from your hard disk instead of having to insert a diskette. Use the COPY command (described in your MS-DOS Reference Manual) to copy the following files from the Reference diskette to your hard disk:

AFDD.EXE  
ESPEED.EXE  
HDSIT.COM  
HDSIT.VER  
ROMBIOS.COM

The Reference diskette also contains files for the Setup program and the System diagnostics program. However, you should always run these programs from the Reference diskette in drive A; so do not copy these files to your hard disk.

### **Note**

Be sure to make backup copies of your Reference diskette. See your MS-DOS Reference Manual for instructions.

## Special Keys on the Keyboard

Certain keys on your keyboard serve special functions when your computer is running MS-DOS or application programs. The keyboard layout is shown below, and special keys are described in the table.

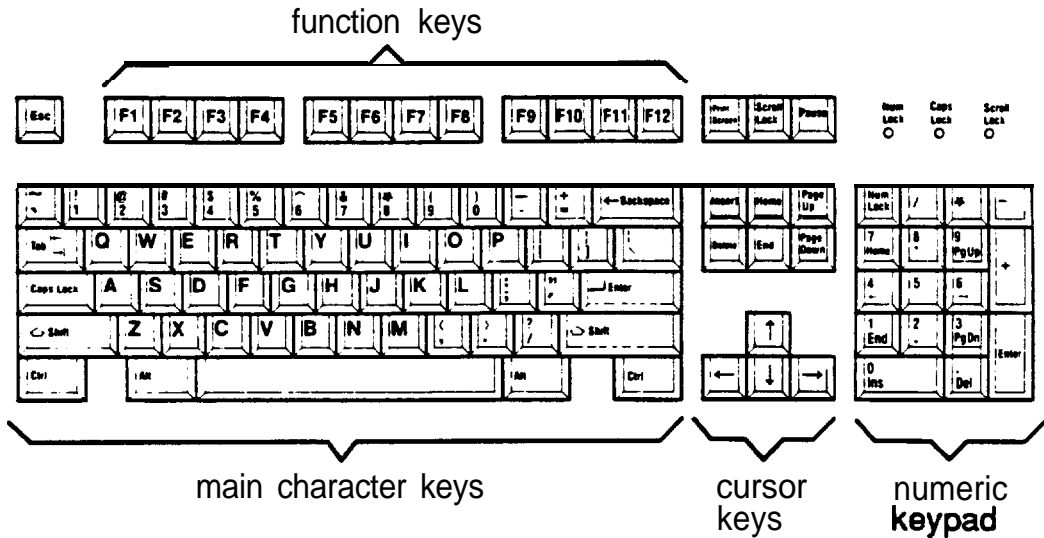

### Key functions

| Key  | Purpose   |
|--|---|
| <br>Tab | Moves the cursor one tab to the right in normal mode and one tab to the left in Shift mode.   |
| Caps Lock  | Changes the letter keys from lower- to uppercase; changes back to lowercase when pressed again. The numeric/symbol keys on the top row of the keyboard and the symbol keys in the main part of the keyboard are not affected. |
| Shift  | Produces uppercase characters or the top symbols on the keys when used with the main character keys. Produces lowercase characters when the Caps Lock function is on.   |
| Ctrl   | Works with other keys to perform special (control) functions, such as editing operations in MS-DOS and various application programs.  |

## Key functions (continued)

| Key   | Purpose   |
|---|---|
| <b>Alt</b>  | <b>Works</b> with other keys to enter alternate character <b>codes</b> or functions.  |
| ← Backspace   | <b>Moves</b> the cursor back one space, deleting the character to the left of the cursor.   |
| <b>J Enter</b>  | Ends a line of keyboard input or executes a command.  |
| Insert (Ins)  | Turns the Insert function on and off.   |
| <b>Delete (Del)</b>   | Deletes the character marked by the cursor.   |
| <b>Home, End</b><br>Page UP (PgUP)<br>Page Down (PgDn)<br>← ↓ → | Control cursor location.  |
| Num Lock  | Changes the function of the numeric/cursor keys from entering numbers to positioning the cursor; changes back when pressed again. |
| <b>Esc</b>  | Cancel the current command line or operation.   |
| <b>F1-F12</b>   | <b>Perform</b> special functions within application programs.   |
| <b>Print Screen</b><br>(PrtSc)                                  | Prints the screen display on a line printer.  |
| SYS Rq (Req)  | Generates the System Request function in some application programs (used with <b>Alt</b> ).                                       |
| <b>Scroll Lock</b>  | Controls scrolling in some applications.  |
| Pause   | Suspends the current operation.   |
| <b>Break</b>  | Terminates the current operation (when used with Ctrl).   |

The **Caps Lock**, **Num Lock**, and **Scroll Lock** keys work as toggles; press the key once to turn on a function and again to turn it off. When the function is enabled, the corresponding light in the upper right corner of the keyboard is on.

---

## ***Stopping a Command or Program***

You may sometimes need to stop a command or program while it is running. Many programs provide a command you can use to cancel or even undo an operation. If you have entered an **MS-DOS** command that you want to stop, try one of the following commands:

- ❑ Hold down the Ctrl key and press C.
- ❑ Hold down the Ctrl key and press **Break**.

These methods may also work in your application program. If not, you may need to reset the computer as described below.

### **Caution**

It is best not to turn off the computer to stop a program or command. If you created new data and have not yet stored it, the data will be erased if you turn off the computer. The computer stores your data in its memory area (RAM) until you save **it**; but the data is erased each time you turn off or reset the computer.

---

## **Resetting the Computer**

Occasionally, you may want to clear the computer's current settings or its memory without turning it off. You can do this by resetting the computer.

For example, if an error occurs and the computer does not respond to your keyboard entries, you can reset it to reload MS-DOS and try again. However, resetting erases any data in memory that you have not saved; so reset only if necessary.

## Caution

Do not reset the computer as a means to exit a program. Some programs classify and store new data when you exit a program in the normal manner. If you reset the computer without properly exiting a program, you may lose data.

To reset the computer, MS-DOS must be either on the hard disk or on a diskette in drive A; so if you do not have a hard disk, insert the **MS-DOS** Startup diskette in drive A.

There are two ways to reset the computer:

- ❑ If you are using MS-DOS, hold down **Ctrl** and **Alt** and press the **Del** key. The screen goes blank for a moment and then the computer should reload MS-DOS. If it doesn't, try the next method.
- ❑ Press the **RESET** button on the front panel. This method works even when the computer does not respond to your keyboard entries.

If resetting the computer does not correct the problem, you probably need to turn it off and reboot it. Remove any diskette(s) from the diskette drive(s). Turn off the computer and wait five seconds. If you do not have a hard disk, insert the MS-DOS Startup diskette in drive A. Then turn on the computer.



---

## ***Using a Power-on Password***

If you set a power-on password when you ran the Setup program, you must enter it every time you turn on the computer or press the **RESET** button. Follow these steps to use your password:

1. If you do not have a hard disk, insert your MS-DOS Startup diskette in drive A.
2. Turn on the computer or press **RESET**. The screen displays a key prompt:

3 

3. At the key prompt, type your power-on password. The key turns when you type a character, but the screen does not display the characters you type. Then press **Enter**.

After you type the password correctly and press **Enter**, a happy face character appears. Then the computer loads MS-DOS.

### **Note**

If you turned on network server mode when you ran the Setup program, you need to use a different procedure to enter your password. See "Using Your Computer as a Network Server" in Chapter 4.

You have three chances to enter the correct password. If you do not enter the correct password at the key prompt, another key prompt appears. If you do not enter the correct password at the second and third key prompts, the screen displays a zero, the keyboard locks up, and you cannot use the computer. Press **RESET** and try to enter the correct password again. (See "Resetting the Computer," above, for instructions.)

## Note

If you do not know the correct password, see “Password Problems” in Appendix A.

## ***Changing a Power-on Password***

To change your power-on password, follow these steps:

1. If you do not have a hard disk, insert your MS-DOS Startup diskette in drive A.
2. Turn on the computer or press **RESET**. At the key prompt, enter your current power-on password followed by a forward slash (/). After the slash, enter the new password you want to use. For example, if your current password is 123 and you want to change it to ABC, type:

123/ABC

Do not use characters requiring the **Shift** key, such as **@, \$, or \***, in your new password. The computer does not recognize the **Shift** key when you use your password to access the system.

The screen does not display what you type.

### **Caution**

Be sure to remember the new power-on password you enter or write it down and keep it in a safe place. If you cannot remember the password you enter now, you will not be able to access your computer the next time you turn it on.

3. Press **Enter**. A happy face character appears and then the computer loads MS-DOS.

Next time you turn on the computer or press **RESET**, use the new password.

### ***Deleting a Power-on Password***

To delete your power-on password, follow these steps:

1. If you do not have a hard disk, insert your MS-DOS Startup diskette in drive A.
2. Turn on the computer or press **RESET**. At the key prompt, enter your current password followed by a forward slash. For example, if your password is 123, type:

1 2 3 /

3. Press **Enter**. A happy face character appears and then the computer loads MS-DOS.

The next time you turn on the computer or press **RESET**, it does not request a password and loads MS-DOS immediately.

#### **Note**

You need to know the password in order to delete it using this method. If you do not know the password, see “Password Problems” in Appendix A.

---

## ***Using Disks and Disk Drives***

The disk drives in your computer allow you to store data on disk, and then retrieve and use your stored data. This section explains how disks work and tells you how to:

- Use different types of diskettes and diskette drives
- Care for your diskettes and diskette drives
- Write-protect diskettes
- Use a single diskette drive system
- Insert and remove diskettes
- Format diskettes
- Make backup copies
- Use a hard disk drive.

### ***How Disks Store Data***

Diskettes are made of flexible plastic coated with magnetic material. This plastic is enclosed in a square jacket that is either slightly flexible (**5<sup>1</sup>/<sub>4</sub>-inch** diskette) or hard (**3<sup>1</sup>/<sub>2</sub>-inch** diskette).

Unlike a diskette, a hard disk is rigid and fixed in place. It is sealed in a protective case to keep it free of dust and dirt. A hard disk stores data the same way that a diskette does, but it works much faster and has a much larger storage capacity.

All disks are divided into data storage compartments by sides, tracks, and sectors. Double-sided diskettes store data on both sides. On each side are concentric rings, called tracks, on which the computer stores your data.

A disk is further divided by sectors, which are similar in shape to pie slices. The figure below provides a simple representation of tracks and sectors.

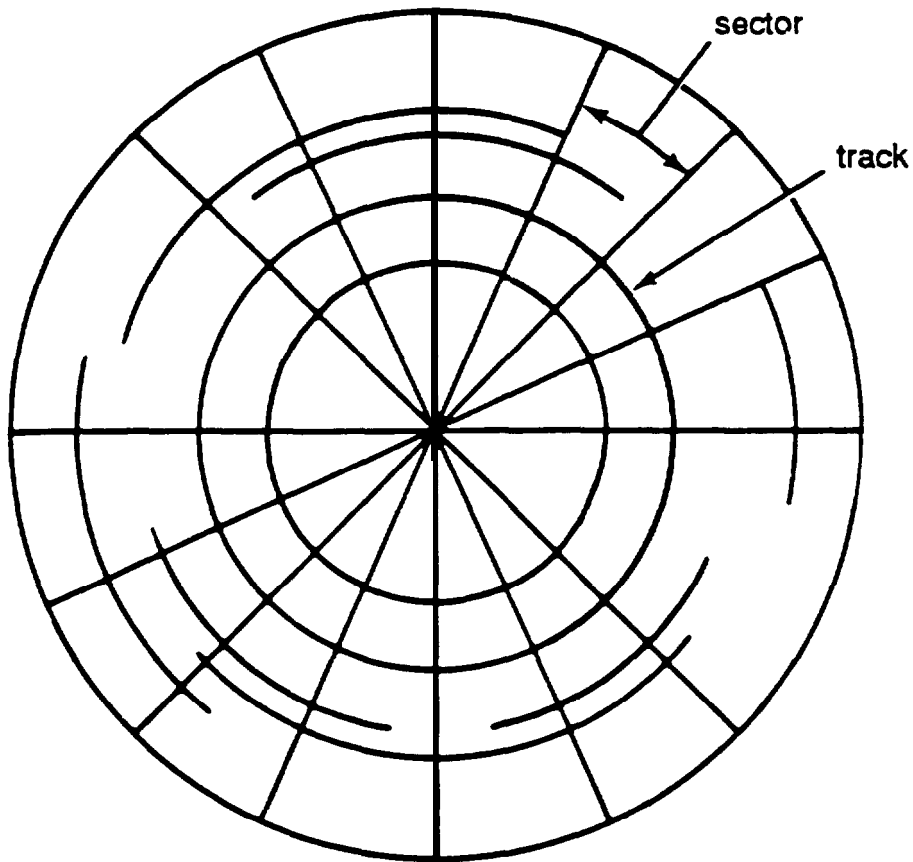

Double-sided, double-density diskettes have either 40 or 80 tracks on each side, and double-sided, high-density diskettes have 80 tracks on each side. Diskettes can have 8,9,15, or 18 sectors per track.

A hard disk consists of two or more platters stacked on top of one another and thus has four or more sides. In addition, a hard disk has many more tracks per side than a diskette, but the number of tracks depends on the capacity of the hard disk. The number of sectors depends on the type of hard disk.

Your computer uses the read/write heads in a disk drive to store and retrieve data on a disk. To write to a disk, the computer spins it in the drive to position the disk so that the area where the data is to be written is under the read/write head. A diskette has an exposed area where the read/write head can access it.

Because data is stored magnetically, you can retrieve it, record over it, and erase it—just as you play, record, and erase music on a cassette tape.

### ***Types of Diskette Drives***

The following list describes the four types of diskette drives you can use in your computer and which diskettes to use with them:

- ❑ 1.2MB drive—Use **5 1/4-inch**, double-sided, high-density, 96 TPI (tracks per inch), 1.2MB diskettes. These diskettes contain 80 tracks per side, 15 sectors per track, and hold up to 1.2MB of information, which is approximately 500 pages of text.

#### Note

MB stands for megabyte, which equals 1024KB (or 1,048,576 bytes). KB stands for kilobyte, which equals 1024 bytes. Each byte represents a single character, such as A, \$, or 3.

- ❑ 1.44MB drive—Use **3 1/2-inch**, double-sided, high-density, 135 TPI, 1.44MB diskettes. These diskettes contain 80 tracks per side, 18 sectors per track, and hold up to 1.44MB of information, which is approximately 600 pages of text.

- ❑ 360KB drive-Use **5<sup>1</sup>/<sub>4</sub>-inch**, doubleaided, double-density, 48 TPI, 360KB diskettes. (YOU can also use single-sided, 160KB or 180KB diskettes.) These diskettes contain 40 tracks per side and 8 or 9 sectors per track. With 8 sectors per track, a diskette holds up to 320KB. With 9 sectors per track, a diskette holds up to 360KB of information, which is approximately 150 pages of text.
- ❑ 720KB drive-Use **3<sup>1</sup>/<sub>2</sub>-inch**, double-sided, double-density, 135 TPI, 720KB diskettes. These diskettes contain 80 tracks per side, 9 sectors per track, and hold up to 720KB of information, which is approximately 300 pages of text.

### Note

You must format a new diskette before you can store data on it. See “Formatting Diskettes,” later in this section.

## Drive and diskette incompatibilities

If your computer has more than one type of diskette drive, or if you use different types of diskettes, you need to be aware of certain incompatibilities between the drives and diskettes.

Because of the type and size differences, you cannot use a **3<sup>1</sup>/<sub>2</sub>-inch** diskette in a **5<sup>1</sup>/<sub>4</sub>-inch** drive or vice versa. There are also limitations on using diskettes that are the same size as the drive but have different capacities. The following tables summarize the possibilities and limitations.

### *5<sup>1</sup>/<sub>4</sub>-inch drive/diskette compatibility*

| Drive type | Diskette types it can read from and write to |
|------------|--|
| 360KB      | 360KB, 320KB, 180KB, 160KB                   |
| 1.2MB      | 1.2MB, 360KB*; 320KB*; 180KB*; 160KB*        |

\* If you write to this diskette in a 1.2MB drive, you may not be able to read it or write to it in a 360KB drive later.

### 3 1/2-inch drive/diskette compatibility

| Drive type | Diskette types it can read from and write to |
|------------|--|
| 720KB      | 720KB  |
| 1.44MB     | 1.44MB, 720KB                                |

Because of these incompatibilities, always indicate the diskette type and density when you label your diskettes. (Usually this information appears on the manufacturer's label.)

If you have any combination of the above drives (1.44 MB, 1.2MB, 720KB, or 360KB), you can copy files from one drive to another-using COPY or XCOPY-as long as the correct diskette type is in each drive. You can also use these commands to copy files between a hard disk and any type of diskette. However, you cannot use the MS-DOS DISKCOPY command to copy from one diskette drive to another if the two drives are not the same type. For more about copying files and diskettes, see your MS-DOS Reference Manual.

### ***Caring for Diskettes and Diskette Drives***

Follow these basic precautions to protect your diskettes and avoid losing data:

- If you have a diskette that contains data you don't want to accidentally write over or erase, be sure you write-protect it. This is especially important for your operating system and application program diskettes. See "Write-protecting Diskettes," below, for more details.
- Do not remove a diskette from the diskette drive or reset or turn off the computer while the drive light is on. This light indicates that the computer is copying data to or from a diskette. If you interrupt this process, you can destroy data.
- Remove all diskettes before you turn off the computer.



- ❑ Keep diskettes away from dust and dirt. Small particles of dust or dirt can scratch the magnetic surface, destroy data, and ruin the read/write heads in a diskette drive.
- ❑ Never wipe, brush, or try to clean diskettes in any way.
- ❑ Keep diskettes in a moderate environment. They work best at normal room temperature and in normal humidity. Don't leave diskettes sitting in the sun, or in extreme cold or heat.
- ❑ Keep diskettes away from magnetic fields. (Remember that diskettes store information magnetically.) There are many magnetic sources in your home or office, such as electrical appliances, telephones, and loudspeakers.
- ❑ Do not place diskettes on top of your monitor or near an external hard disk drive.
- ❑ Always hold a **5<sup>1</sup>/<sub>4</sub>-inch** diskette by its protective jacket and never touch the magnetic surface exposed by the read/write slot. The oils on your fingertips can damage it.
- ❑ Do not place anything on top of your diskettes, and be sure they do not get bent.
- ❑ Carefully label your diskettes and indicate the type and density. Attach the label only along the top of a diskette (next to the manufacturer's label). Do not stick several labels on top of one another; too many labels can make it difficult to insert and remove the diskette in the drive.
- ❑ Write on a diskette label before you attach it to the diskette. If you need to write on a label that is already on the diskette, use only a soft-tip pen-not a ballpoint pen or a pencil.
- ❑ Store diskettes in their protective envelopes and in a proper location, such as a diskette container. Do not store diskettes flat or stack them on top of each other.

## ***Write-protecting Diskettes***

You can write-protect a diskette to prevent its data from being altered. When a diskette is write-protected, you can read it and copy data from it, but you cannot store new data on it or delete any files it contains. If you try to change data stored on a write-protected diskette, MS-DOS displays an error message.

To write-protect a **5<sup>1</sup>/<sub>4</sub>-inch** diskette, cover the small, rectangular notch (shown below) with an adhesive write-protect tab. Write-protect tabs usually are included in a new package of blank **5<sup>1</sup>/<sub>4</sub>-inch** diskettes.

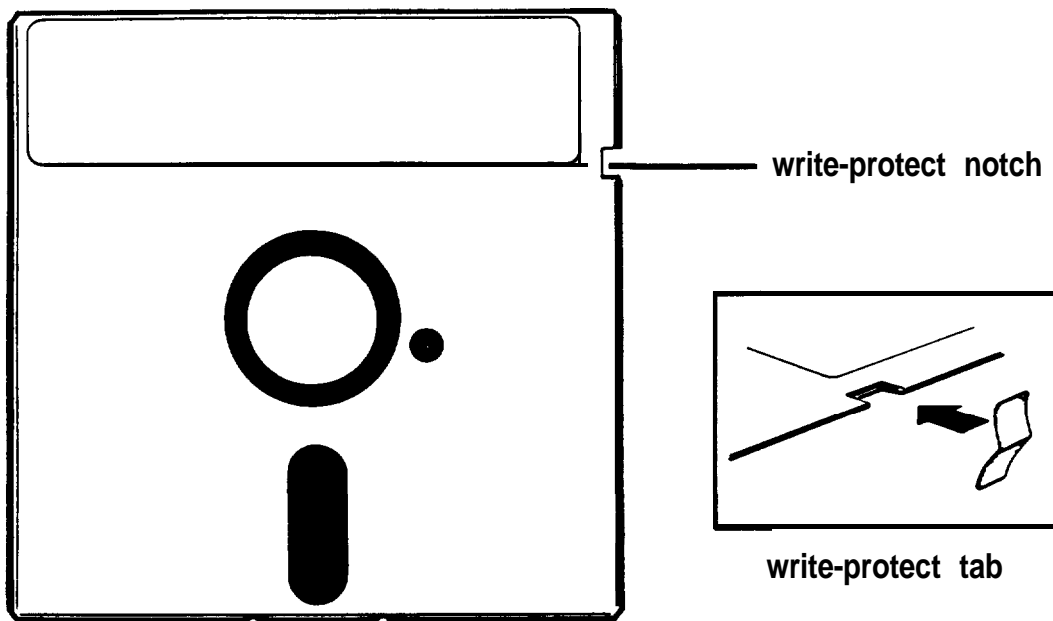

To remove the write protection, peel off the write-protect tab.

On a **3<sup>1</sup>/<sub>2</sub>-inch** diskette, the write-protect device is a small switch on the back of the diskette in the lower right corner, shown below. To write-protect a **3<sup>1</sup>/<sub>2</sub>-inch** diskette, slide the switch toward the edge of the diskette until it clicks into position, exposing a hole in the corner.

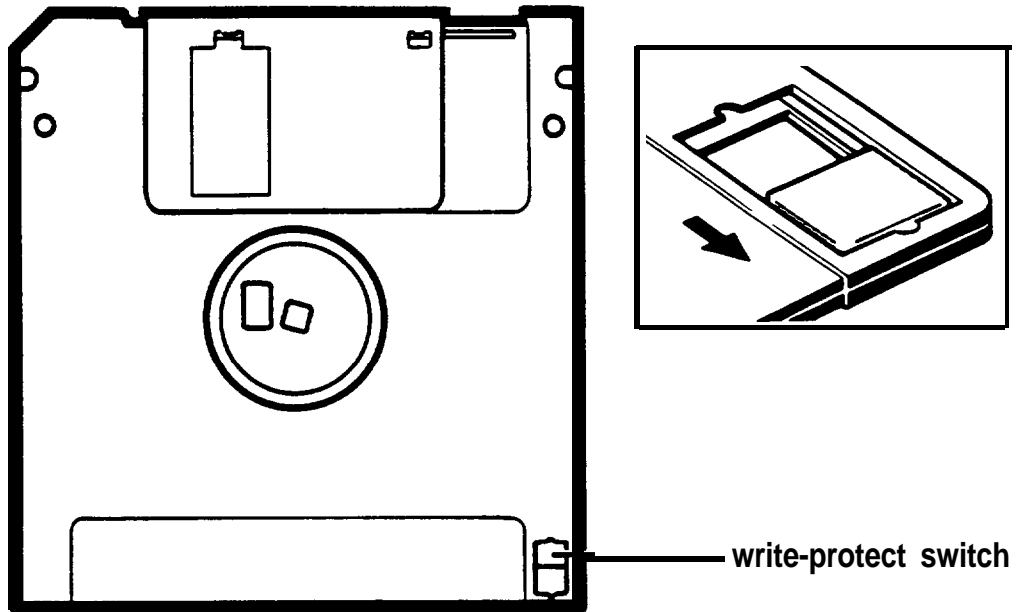

To remove the write protection, slide the switch toward the center of the diskette until it clicks into position and the hole is covered.

#### Note

Some program diskettes have no notch or switch so they are permanently write-protected. This protects them from being accidentally erased or altered.

## ***Using a Single Diskette Drive System***

MS-DOS expects the computer to have at least two diskette drives and displays prompts and messages accordingly. Usually, MS-DOS recognizes the first diskette drive (the top drive) as A and a second diskette drive as B. If you have only one diskette drive, MS-DOS can treat it as both A and B when you need to perform operations that normally require two diskette drives.

For example, if you enter a command to copy data from A to B, MS-DOS copies the data from the first diskette you place in the drive (which would be drive A) to the computer's memory. Then MS-DOS prompts you to insert another diskette (for drive B) and copies the data from memory to the new diskette. When copying is complete, you see a prompt to insert the original diskette (A).

Because you may often swap diskettes this way, it is important to remember which diskette is which. It is also a good idea to write-protect your original diskette. See "Write-protecting Diskettes," above.

If you have a hard disk and one diskette drive, you can load the operating system and application programs from the hard disk, create and store your data there, and use the diskette drive just for copying data to or from diskettes.

However, if you have only one diskette drive and no hard disk, you need to use that drive to load the operating system as well as any application program you are using. First, insert the operating system diskette (the Startup diskette, for example) in drive A and load the operating system; this copies it to the computer's memory (RAM) so you do not need to leave the system diskette in the drive. Then remove the system diskette and insert your application program diskette to load that data into memory, too. See your application program manual for detailed instructions.

## Note

You can load MS-DOS from an application program diskette if that diskette contains the operating system. See your MS-DOS Reference Manual for information about creating a system diskette.

## ***Inserting and Removing Diskettes***

If you have a **5<sup>1</sup>/<sub>4</sub>-inch** diskette drive, insert a diskette as follows: hold the diskette with the label facing up and the read/write slot leading into the drive, as shown below.

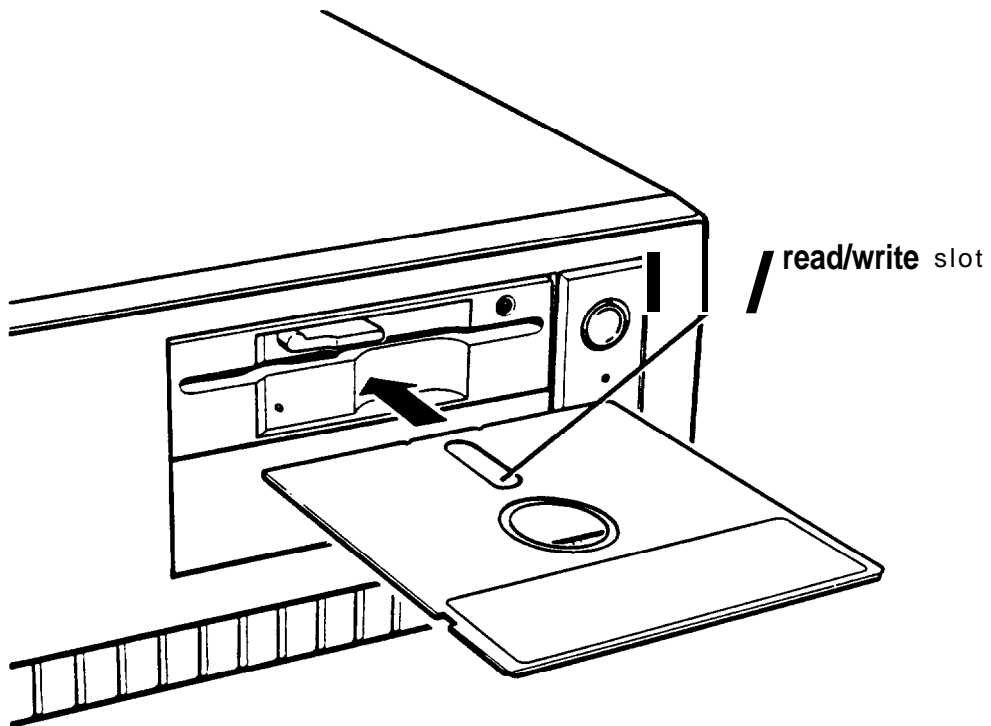

Slide the diskette into the slot until it is in all the way. Then turn the latch down to lock it in a vertical position. This keeps the diskette in place and allows the read/write heads in the diskette drive to access the diskette.

When you want to remove a diskette, first make sure the disk drive light is off. Then flip up the latch and carefully pull out the diskette. Place it in its protective envelope and store it in a proper location, such as a diskette container.

If you have a 3 1/2-inch diskette drive, insert the diskette with the label facing up and the metal shutter leading into the drive as shown in the following illustration. Slide the diskette into the drive until it clicks into place.

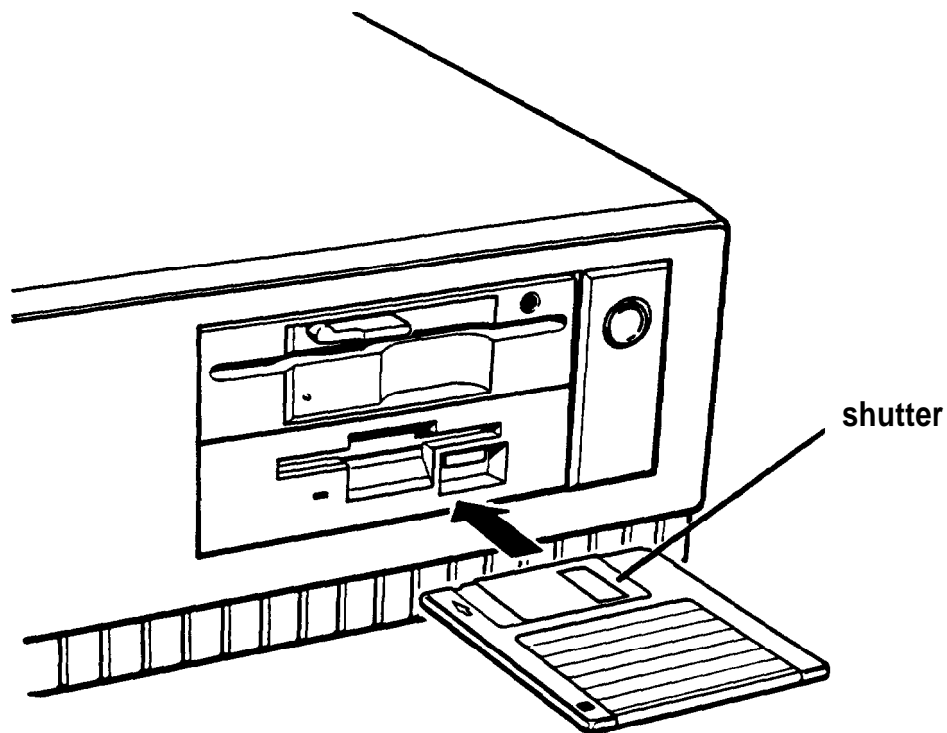

When you want to remove the diskette, make sure the drive light is off; then press the release button. When the diskette pops out, remove it and store it properly.

### **Caution**

Never remove a diskette or reset or turn off the computer while a diskette drive light is on. You could lose your data. **Also, be sure to** remove all diskettes before you turn off the computer.

## ***Formatting Diskettes***

Before you can store data on a new diskette, you must format it using the `FORMAT` command. Formatting prepares the diskette so that MS-DOS can write data on it. You need to do this only once, before you use the diskette for the first time.

You can also reformat previously used diskettes to store new data. This process erases all the data on the diskette, so be sure you do not want to save any of the files on a diskette before you format it. See your MS-DOS Reference Manual for instructions on using the `FORMAT` command.

## ***Making Backup Copies***

It is important to make copies of all your data and system diskettes. Make backup (or working) copies of all diskettes that contain programs, such as your MS-DOS diskettes and the original Reference diskette that came with your computer. Then use only the copies. Store the original diskettes in a safe place away from your working diskettes. Also, copy your data diskettes regularly, whenever you revise them (to keep them up-to-date) and store them away from your originals.

If you have a hard disk, you'll probably use it to store the programs and data files you use regularly. Keep backup copies of all your files on diskettes.

You can copy your data in several ways:

- You can use the `COPY` or `XCOPY` command to copy individual files or groups of files.
- You can use the `DISKCOPY` command to make an exact duplicate of a diskette.

- ❑ You can use the BACKUP command to back up hard disk files to diskettes. Because BACKUP can split large files across two or more diskettes, it makes more efficient use of diskette space than COPY or XCOPY.

See your MS-DOS Reference Manual for instructions on using these commands.

## ***Using a Hard Disk Drive***

Using a hard disk is similar to using a diskette. However, the hard disk provides several advantages:

- ❑ A 40MB hard disk can store as much data as approximately thirty-three 1.2MB diskettes or thirty 1.44MB diskettes, and a 100MB hard disk can store as much data as approximately eighty-two 1.2MB diskettes or seventy 1.44MB diskettes.
- ❑ Your computer can perform all disk-related operations faster.
- ❑ You can store frequently used programs and data files on the hard disk, eliminating the inconvenience of swapping diskettes to access different files.

The added storage capacity makes it easy to move back and forth between different programs and data files. However, because it is so easy to add programs and files to your hard disk, you may find yourself trying to organize hundreds of files.

MS-DOS lets you keep related files together in directories and subdirectories so they are easy to find and use. See your MS-DOS Reference Manual for instructions on managing your files and directories.

A hard disk must be partitioned and formatted before you can use it. Be sure you have performed the procedures in your MS-DOS Installation Guide to prepare your hard disk for use.



## Backing up the hard disk

While the hard disk is very reliable, it is essential to back up your hard disk files to diskettes in case you lose some data accidentally. Make copies of all your system and application program diskettes before copying the programs to the hard disk. After you create data files on the hard disk, be sure to copy them to diskettes whenever you revise them to keep your backup diskettes up-to-date.

## Caring for your hard disk drive

Follow these precautions to protect your hard disk drive from damage and to avoid losing data:

- Never turn off or reset the computer when the hard disk access light is on. This light indicates that the computer is copying data to or from the hard disk. If you interrupt this process, you can lose data.
- Never attempt to open the hard disk drive. The disk itself is enclosed in a sealed container to protect it from dust.
- Before you **move** your computer even a short distance, you may need to run the HDSIT program to prepare the hard disk for moving, as described below.

## Preparing the hard disk for moving

If you need to move your computer to a new location-whether it is across the country or just across the room-you may want to run the HDSIT program to protect the hard disk during the move.

HDSIT moves the disk drive's read/write heads to a region on the disk surface that does not contain data, and locks them securely in position. This protects the hard disk from being damaged if the computer is bumped accidentally.

Many hard disk drives, including all Epson drives, automatically park their heads when you turn off the computer. If your hard disk drive does not do this, or if you are not sure that it does, be sure to run HDSIT.

Follow these steps to run HDSIT:

1. Exit any program you are using and make sure the MS-DOS command prompt appears on the screen.
2. If you copied HDSIT to your hard disk (as described at the beginning of this chapter), log onto the directory of the hard disk that contains the HDSIT files.

If you did not copy HDSIT to your hard disk, insert the Reference diskette in drive A. Then type A: and press **Enter** to log onto that drive.

3. Type the following and press **Enter**:

HDSIT

You see a message on the screen that tells you the disk drive's read/write heads will remain locked until you reset the computer or turn the power off and on again. The computer locks the heads and disables the keyboard. Remove any diskettes and turn off the computer. You are now ready to move it to the new location.

#### Note

If your computer came with a **5<sup>1</sup>/<sub>4</sub>-inch** diskette drive and you still have the original diskette drive protector card, you may want to insert it into the drive prior to shipping your computer to protect the read/write heads.

### ***Enhancing System Operations***

This chapter tells you how to use the following procedures to enhance the operation of your computer:

- Using AUTOEXEC.BAT and other batch files
- Changing the processor speed
- Reassigning the diskette drives
- Using your computer as a network server
- Using expanded memory beyond 640KB
- Using special VGA features.

---

### ***Using AUTOEXEC.BAT and Other Batch Files***

As you get used to using MS-DOS and your application programs, you may find that there are commands you need to run frequently. You can automate the execution of these commands by listing them in a special file called a “batch” file. When you type the name of the batch file and press **Enter**, MS-DOS executes the commands in the file just as if you had typed each command from the keyboard.

If you have a word processing program that can save a file as a text-only file (sometimes called an ASCII file), you can use that program to create a batch file. You can also use the MS-DOS COPY or EDLIN command to create the file. See your MS-DOS Reference Manual for instructions on creating and using batch files.

One batch file that you may find particularly useful is called AUTOEXEC.BAT. Every time you turn on your computer, MS-DOS looks for the AUTOEXEC.BAT file and automatically executes each of the commands.

When you install MS-DOS, it automatically creates an AUTOEXEC.BAT file for you. To create or modify the file, you can use the same programs that you use to create any other batch file (COPY, EDLIN, or a word processing program that can save a file as a text-only file). However, be sure to name the file AUTOEXEC.BAT and store it in the root directory of the hard disk or diskette from which you load MS-DOS.

See your MS-DOS Reference Manual for more information about your AUTOEXEC.BAT file.

---

## ***Changing the Processor Speed***

Your computer's processor can operate at two speeds: high and low. High speed is 20 MHz and low speed simulates an 8 MHz processor speed. On high, the computer can access memory faster than on low. Your processor is set to operate at high speed unless you change the speed to low or set the speed to change automatically.

### Note

When your computer is operating at high speed, the **TURBO** light on the front panel is illuminated. The **TURBO** light is off when your computer is operating at low speed.

You should use high speed for almost everything you do since your programs will work faster. However, certain application programs have specific timing requirements for diskette access and can run only at the slower speed. See the manual for your program to determine if this is the case.

Some copy-protected programs require the computer to run at low speed while accessing the program on a diskette. These programs also usually require you to leave a key disk-the diskette that contains the copy protection-in the diskette drive. If you use a copy-protected program often, you may want to set your processor speed to change automatically to low speed when accessing the diskette and return to high speed when it is finished.

There are different types of copy-protected programs. Depending on the type you have, you may or may not want to set the processor to automatic speed. Follow these guidelines:

- ❑ If you are using a copy-protected program that can run only on a diskette or that requires a key disk, try to load the program on high speed. If this works, you do not need to set the speed to change automatically. If you can't load the program on high, set the speed to change automatically.
- ❑ If you are using a copy-protected program that does not require a key disk but requires a special procedure to install the program on a hard disk, set the speed to low while you are installing the program. Once it is installed, set the speed to high, where you should be able to leave it while you load and run the program.

If this does not work, try installing and loading the program at low speed and then change to high speed to run it. Do not set the speed to change automatically.

There are three ways to change the processor speed:

- ❑ Run the Setup program on your Reference diskette
- ❑ Enter a keyboard command
- ❑ Run the ESPEED program.

If you frequently use programs that require the processor to operate at low speed or require the automatic speed change when your computer is accessing a diskette, use Setup to change the processor speed. See Chapter 2 for instructions.

If you use these programs only occasionally, you should use the keyboard commands or the ESPEED program (described below) to change the processor speed.

### ***Entering Keyboard Commands***

You can change the processor speed by entering one of the following commands at the MS-DOS prompt:

- |            |  |
|------------|--|
| Ctrl Alt + | Changes the speed to high (20 MHz).  |
| Ctrl Alt - | Changes the speed to low (simulated 8 MHz).                                |
| Ctrl Alt * | Tells the computer to change to low speed when it is accessing a diskette. |

For the +, -, and • characters, press the keys on the numeric keypad. The commands do not work if you use the characters on the main keyboard.

#### Note

You can use the commands listed above while you are running a program. However, if you are running a program that uses one of the same commands for another function, you cannot use that command to change the processor speed. For example, if you are running a program that uses the **Ctrl Alt -** command to move the cursor, you cannot enter **Ctrl Alt -** to change the processor speed to low. When you exit the program, you can enter these commands at the MS-DOS prompt. Another alternative is to use the ESPEED program, described below.

To enter these commands, hold down the **Ctrl** key and the **Alt** key and press the +, -, or \* key located on the *numeric keypad*. The speed setting remains in effect until you press the **RESET** button or turn off the computer, or until you change it again using the Setup program, another keyboard command, or the ESPEED program, described below.

### ***Using the ESPEED Program***

The ESPEED program allows you to change the processor speed to high or low, or set the speed to change automatically. This method is convenient if your application program does not recognize the **Ctrl** keyboard commands or if you want to include the program command in a batch file.

The ESPEED program is provided with your system on the Reference diskette. If you do not have a hard disk, insert your Reference diskette in drive A and log onto drive A before you enter the command to start the program.

If you have a hard disk drive, copy the file ESPEED.EXE from your Reference diskette onto your hard disk-if you have not already done so-and run the program from there. (See “Copying the Reference Diskette Files” in Chapter 3 for more information.)

To run the ESPEED program, type the following at the MS-DOS command prompt and press **Enter**:

```
ESPEED
```

You see the following message:

```
Usage: ESPEED [[/H][L] [/All  
    /High          set High speed (no auto)  
    /Low           set Low speed (no auto)  
    /Auto          set Auto speed
```

The message tells you the switches you should use to set the speed to high, low, or automatic speed. At the MS-DOS prompt, type the ESPEED command again and include the appropriate switch, such as the following:

```
ESPEED /A
```

This command sets the processor speed to change to low speed automatically when the computer **accesses** a diskette.

If you include the switch when you type the initial ESPEED command, the program changes the speed without displaying the command options.

The processor speed you set remains in effect until you press the **RESET** button or turn off the computer, or until you change it using the Setup program, a keyboard command, or the ESPEED program again.

### **Entering the ESPEED command in a batch file**

You may want to run the ESPEED program by including the command in a batch file. For example, if you have a program called SAMPLE which requires an 8 MHz processor speed when the program is running on a diskette, you could include the following commands in a batch file to start the SAMPLE program:

```
ESPEED /A  
SAMPLE
```

You could name the batch file SAMP.BAT. Whenever you need to run the SAMPLE program, insert the program diskette into drive A. Then type SAMP and press **Enter**.

The computer changes the processor speed to automatic and starts the SAMPLE program. When you access the program on the diskette, the speed changes to low and then returns to high when you are finished.



See your MS-DOS Reference Manual for instructions on creating and using batch files.

---

## ***Reassigning the Diskette Drives***

If your system has two diskette drives, they are connected inside your computer so that the top drive is A and the bottom drive is B. Because drive A is the “boot” drive, whenever you want to load the operating system or a bootable program from a diskette, you must insert the diskette into drive A.

If both of your drives are the same type-S/-inch, 1.2MB capacity, for example-you never need to reassign the drives. If your two drives are different types, however, you may need to change the drive letter assignments so you can boot the computer from drive B. For example, you may have a **3<sup>1</sup>/<sub>2</sub>-inch** program disk that you need to use to boot the computer. Or you may have an application program that requires you to leave the **3<sup>1</sup>/<sub>2</sub>-inch** key disk in drive A while you run the program.

For these situations, you can reverse the drive assignments to make the top drive B and the bottom drive A. There are two ways to do this:

- Insert the diskette in the drive you want to boot from and turn on the computer. The drive automatically becomes drive A.
- Run the AFDD program to reassign the drive. See “Using the AFDD Program,” below, for instructions.

Your assignments remain in effect until you press the **RESET** button or turn off the computer, or until you reassign the drives to their original letters. The reassignment remains in effect if you reset the computer from your hard disk by pressing **Ctrl Alt Del**.

## **Using the AFDD Program**

The AFDD program reverses the current diskette drive assignments and resets the system. When you are done using the reversed drive assignments, you can use the AFDD program again to reassign the drives to their original configuration.

The AFDD program is provided with your system on the Reference diskette. If you do not have a hard disk, insert your Reference diskette in drive A and log onto drive A before you enter the command to start the program.

If you have a hard disk drive, copy the file AFDD.EXE from your Reference diskette onto your hard disk (if you have not already done so); then you can run the program from there. See “Copying the Reference and Utility Files” in Chapter 3 for more information.

To run the AFDD program, type the following at the MS-DOS command prompt and press **Enter**:

```
AFDD
```

You see a message such as the following:

|          | New Assign |    | Present |
|----------|------------|----|---------|
| Drive A: | 1.44MB     | <= | 1.2MB   |
| Drive B: | 1.2MB      | <= | 1.44MB  |

```
(S)et and Reboot, Any other key to  
abort ? _
```

If you inserted the Reference diskette to run the AFDD program, remove it now.

If you want to change the drive assignments, press **S**. The system reboots and loads MS-DOS, and the new drive assignments take effect. If you do not want to change the drive assignments, press any other key.

If you are running the AFDD program from a hard disk, you can reassign the drives and reset the computer automatically. Type the following command and press **Enter**:

```
AFDD /S
```

The `/s` switch tells the AFDD program to reset the computer, load MS-DOS, and change the diskette drive assignments without displaying the message.

### Note

You may want to run the AFDD program by including the command in a batch file. See your MS-DOS Reference Manual for instructions on creating and using batch files.

---

## ***Using Your Computer as a Network Server***

If your computer is set up in a network, you may want to use your system as the network server. A network server is the master computer in a network and provides storage space for the other computers connected to it. The network server can write files to and read files from the other computers, making it the most powerful computer in a network.

Even if no one is typing commands at the network server keyboard, the server can process commands sent to it from other computers. When your computer is operating in this special situation, you may want to prevent unauthorized users from entering commands at the network server keyboard. To provide this security, you can enable a power-on password in network server mode.

When you enable a power-on password but do not use network server mode, you enter the password before the computer loads MS-DOS. Once you load **MS-DOS**, anyone can access your system by typing commands on the keyboard. However, if you enable a power-on password and turn on network server mode, you can load MS-DOS before you enter the password. This allows other computers in the network to access the system, but prevents unauthorized users from entering commands at your keyboard and using any network server access privileges.

When you boot the computer in network server mode, you do not see the key prompt (  ) to tell you when to enter the password (as you would if network server mode was turned off). The password prompt is hidden to prevent unauthorized users from knowing that a password is required.

You do not have to set a password or enable network server mode to use your computer as a network server, but it prevents unauthorized access to your computer when it is operating in this special situation.

See “Setting the Power-on Password” in Chapter 2 for instructions on how to set a power-on password and enable network server mode.

### ***Using a Password in Network Server Mode***

When you turn on the computer or press **RESET**, the computer loads MS-DOS and you see either the MS-DOS command prompt or the first screen displayed by your networking software. You do not see the key prompt (  ) even though the computer is now waiting for you to enter the correct password.

Follow these steps to enter your password:

1. Turn on your computer or press **RESET**.
2. Type your password and press **Enter**. The screen does not display what you type.

Now you should be able to use your computer as desired. Press a key such as Enter to see if the keyboard accepts your command. If you entered an incorrect password, the computer does not respond. Type the correct password, press **Enter**, and try using the computer again.

#### Note

You cannot change or delete a power-on password and remain in network server mode. You must run Setup on the Reference diskette to turn off network server mode first. See Chapter 2 for instructions. Then you can change or delete the password by following the instructions in Chapter 3.

If you forget the power-on password, see “Password Problems” in Appendix A.

---

### ***Using Expanded Memory Beyond 640KB***

The Equity 386SX/20 PLUS comes with 2MB of random access memory. MS-DOS and your application programs that run under MS-DOS use the first 640KB of memory. You can use the unused memory above 640KB as extended memory, or you can use it as expanded memory, as described below.

Expanded memory can be used by application programs (such as Lotus® 1-2-3®) that support the Lotus/Intel/Microsoft Expanded Memory Specification (LIM 4.0 EMS). To take advantage of expanded memory, you need to use a memory manager to convert the computer’s extended memory to expanded memory.

If you selected a memory management software package when you bought your Equity 386SX/20 PLUS, you can use the memory manager with either version of MS-DOS. Just follow the instructions included with the package.

If you are using version 4.01 of MS-DOS and you did not get a memory manager, you can use the MS-DOS program EMM386SYS to convert your extended memory to expanded memory. See your MS-DOS Reference Manual for instructions on using EMM386.SYS.

If you are using version 3.3 of MS-DOS and you did not get a memory manager with your system, ask your Epson dealer which expanded memory manager program you should use.

---

## ***Using Special VGA Features***

Your built-in VGA (video graphics array) display adapter supports both standard VGA monitors and multi-frequency monitors with analog connectors in non-interlaced mode. The VGA adapter allows these monitors to operate in all standard VGA modes without requiring any special device drivers.

However, if you want to use super VGA modes, you can install one or more of the device drivers provided on the Utility diskette that came with your system. These drivers allow you to use all of the capabilities of your monitor and your built-in VGA display adapter.

The device drivers provide VGA features such as these:

- 800 x 600 resolution in graphics modes with 16 colors
- Resolutions up to 640 x 480 in graphics modes with 256 colors
- 132-column text mode in 16 colors.

### *Note*

To use graphic display drivers in 800 x 600 resolution, you must have a multi-frequency monitor capable of displaying these resolutions. Standard VGA monitors are not able to display them.

The VGA Utilities diskette that came with your system contains device drivers for various application programs that require them. The diskettes also provide the following special utilities:

- INSTALL**      The **INSTALL** utility automatically loads the necessary drivers for the application, resolution, and colors you select.
- VGAMODE**     The **VGAMODE** utility lets you switch between the various VGA modes.

For more information about the VGA device drivers and the utilities, see the VGA Utilities booklet that came with your computer.

Your built-in VGA display adapter supports Edsun's CEG technology, which refines the jagged lines in the images on the screen. When used with the appropriate application software and device drivers, this technology gives you a clearer, more accurate representation of graphics and text.

The CEG Utilities diskette that came with your system contains the device drivers available for various application programs. The drivers let you take advantage of the CEG technology for specific programs. See your CEG Utilities booklet for details.

### ***Accessing Internal Components***

Your computer is designed so you can easily install optional equipment such as a disk drive, a math coprocessor, or an option card. Chapters 6 and 7 describe how to install options in your computer; but first you must open the computer to access the internal components. Follow the instructions in this chapter when you need to perform these steps:

- Remove the computer's cover
- Remove the subassembly
- Replace the subassembly
- Replace the cover.

Be sure to heed all the cautions and warnings so you do not injure yourself or damage the computer. If you have any reservations about performing these steps yourself, ask your Epson dealer for assistance.

#### Note

You only remove the subassembly to access jumpers or the math coprocessor socket or to install or remove a disk drive. You do not need to remove the subassembly to install an option card or memory modules.



---

## ***Removing the Cover***

Follow these steps to remove the cover from your computer:

1. Turn off the computer and then any peripheral devices (including the monitor and printer).
2. If the monitor is on top of the computer, lift it off and set it to one side.
3. Disconnect the computer's power cable from the electrical outlet and from the back panel. Then disconnect any peripheral device cables that are connected to the computer, including the keyboard cable.
4. Turn the computer around so the back panel is facing you. As shown below, the cover is secured by a large screw. Turn the screw counterclockwise to unlock the cover.

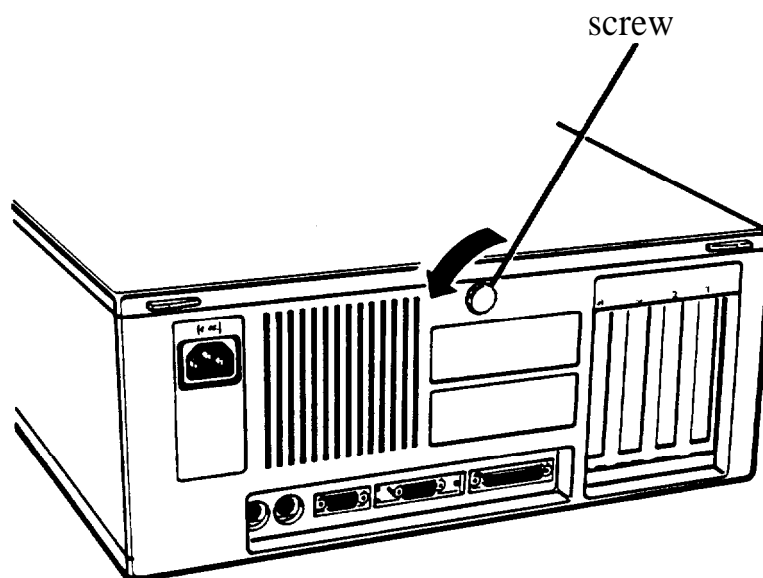

Notice the icons under the screw:

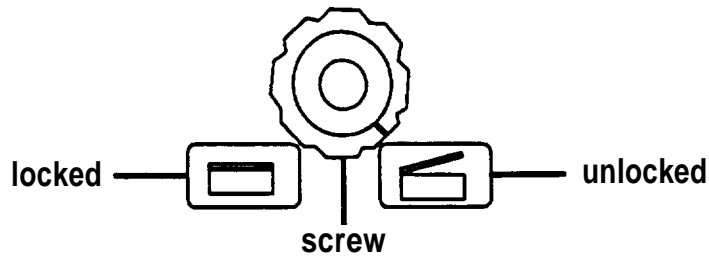

5. The cover is also secured by two latches on the back of the cover near the corners. Press both latches inward and then lift up the cover from the back panel. You might meet some resistance from the grounding tabs along the inside of the cover.

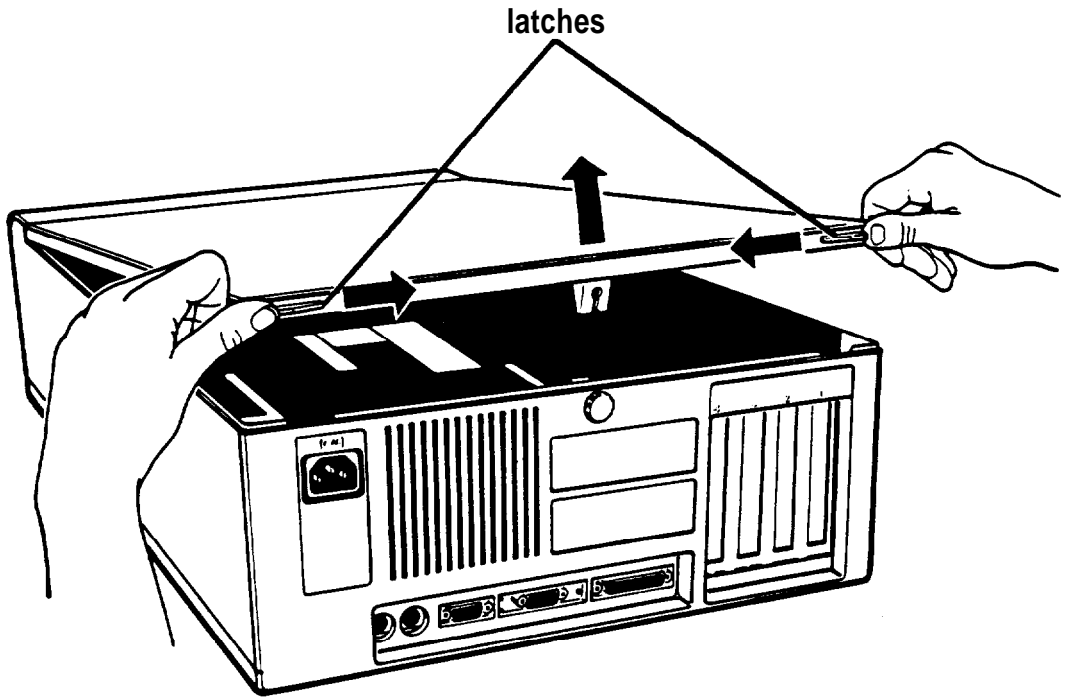

6. Pull the cover away from the front of the computer to completely remove it. Then set it aside.

7. Before you touch any of the components inside, touch the inside of the computer's back panel, as shown below to ground yourself and avoid an electric shock and to avoid damaging the components.

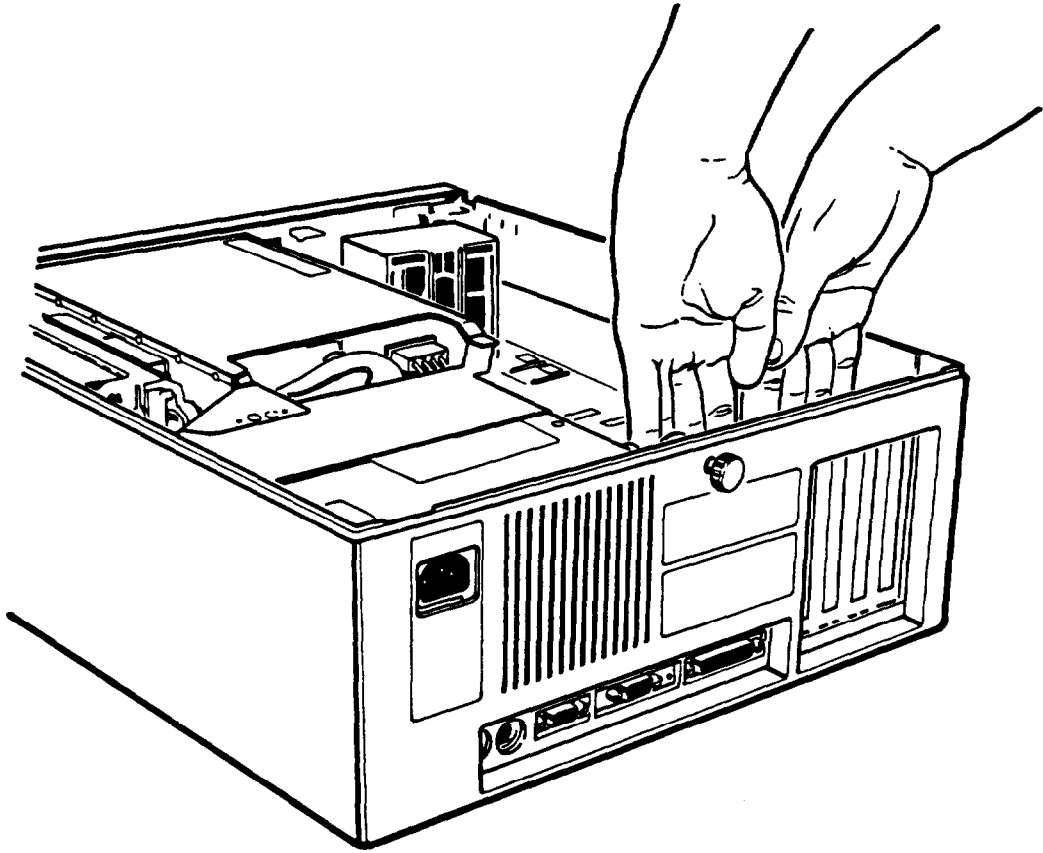

#### WARNING

Be sure to ground yourself to the inside back panel of the computer every time you remove the cover. If you are not properly grounded, you could generate an electric shock when you touch a component.

---

## ***Removing the Subassembly***

In order to install disk drives or access the jumpers or math coprocessor socket on your computer's main system board, you need to remove the subassembly. The subassembly is the large metal casing that holds the horizontal drive bays and the power supply, as shown below.

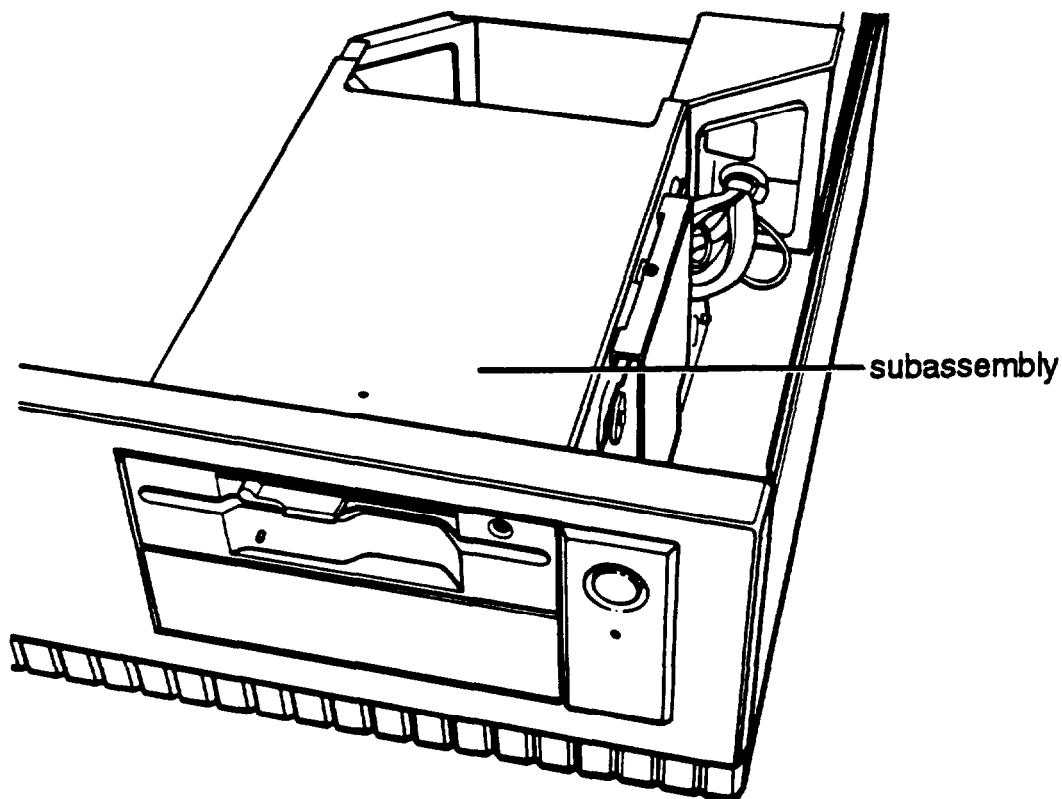

Follow these steps to remove the subassembly:

1. Turn the computer so the front panel is facing you.

2. Remove the front panel from the computer by lifting up slightly on the three clips at the top of the panel and tilting it toward you. Then set it aside.

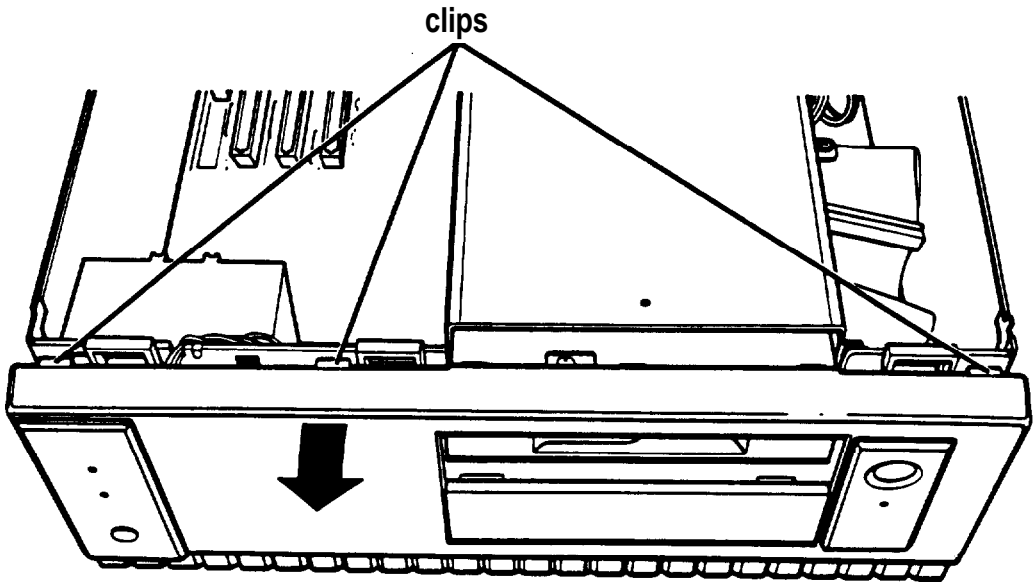

3. To lift the subassembly from the front of the computer, place your thumbs under the diskette drive and grasp the top edge of the computer with the rest of your fingers, as shown below. Then lift up the subassembly with your thumbs.

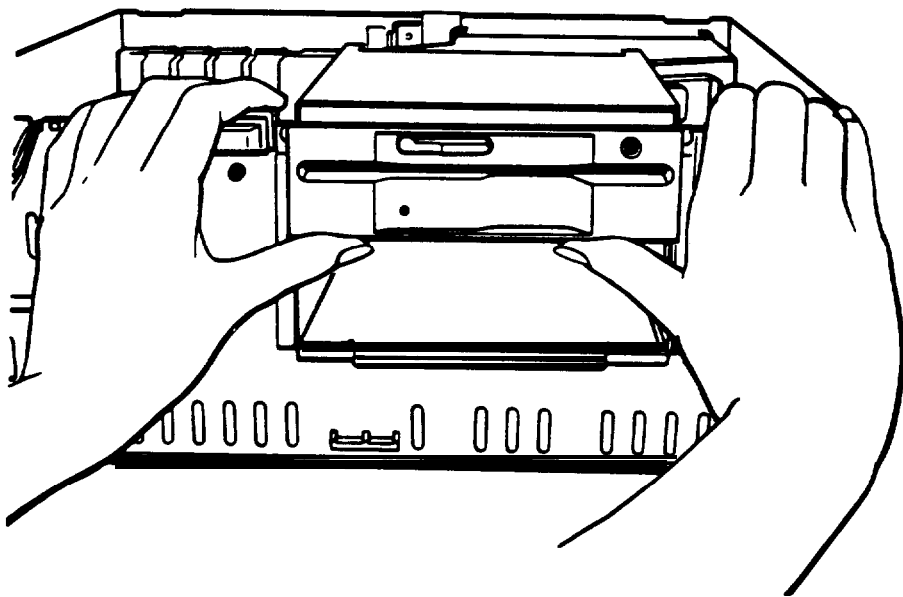

4. Raise the front of the subassembly to a slight angle.

Use one of your hands to hold up the subassembly at an angle or have someone hold it up for you. With your other hand, reach under the subassembly and disconnect the hard disk drive cable attached to the front right side of the main system board, as shown below. Grasp the cable by its plastic connector and pull it straight up to remove it from the socket. Do not pull on the cable.

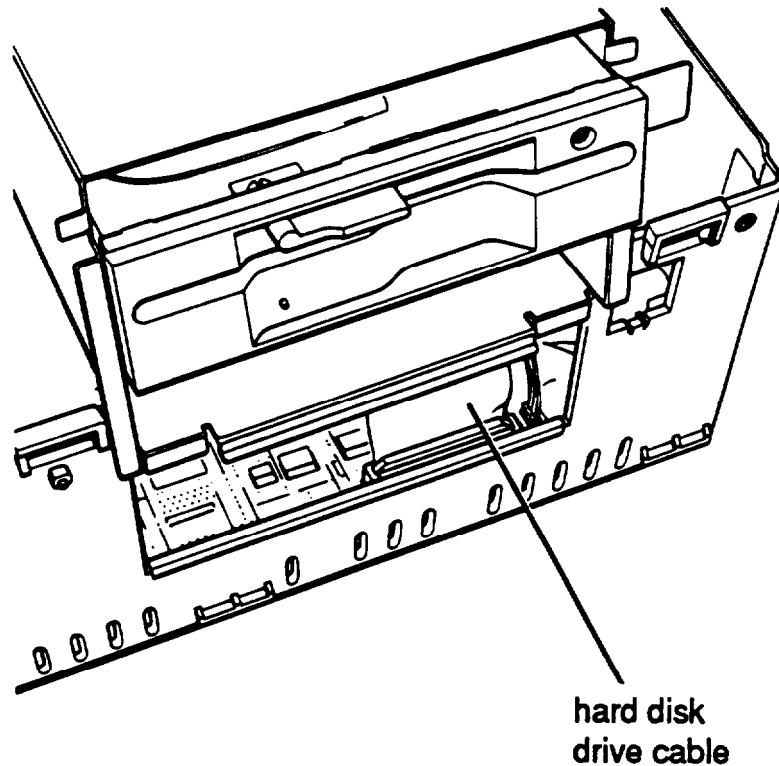

5. The diskette drive cable is connected to the socket just behind the hard disk drive socket. Disconnect this cable in the same manner.

6. Still holding up the subassembly, reach further back underneath it and disconnect the two power supply cables connected to the back right side of the main system board, as shown below. Pull each of the connectors straight up. Do not pull on the cables.

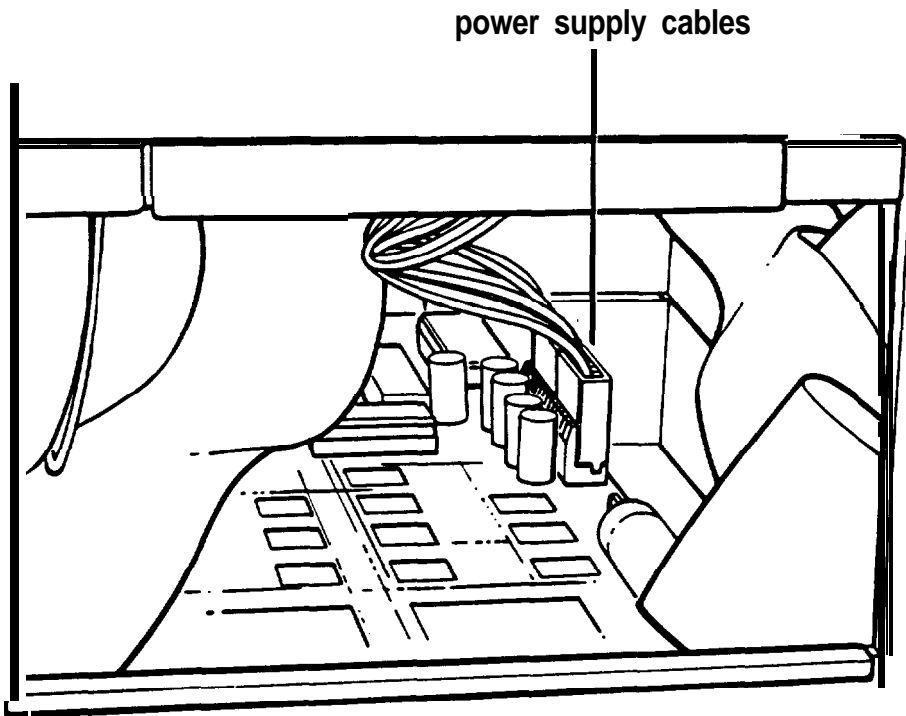

7. Lift the entire subassembly out of the computer and carefully place it on your work surface.

---

### ***Replacing the Subassembly***

Follow the steps below to replace the subassembly inside your computer:

1. Notice that there are four mounting slots on the back of the subassembly: two in the upper corners and two in the lower corners.

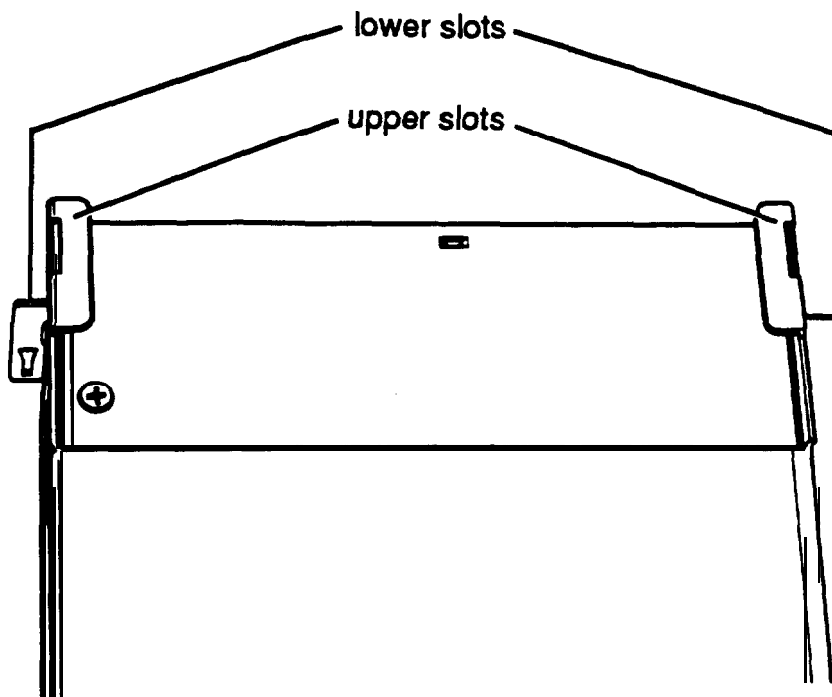

There are four corresponding tabs on the inside back panel of the computer; these tabs fit into the openings in the subassembly slots.

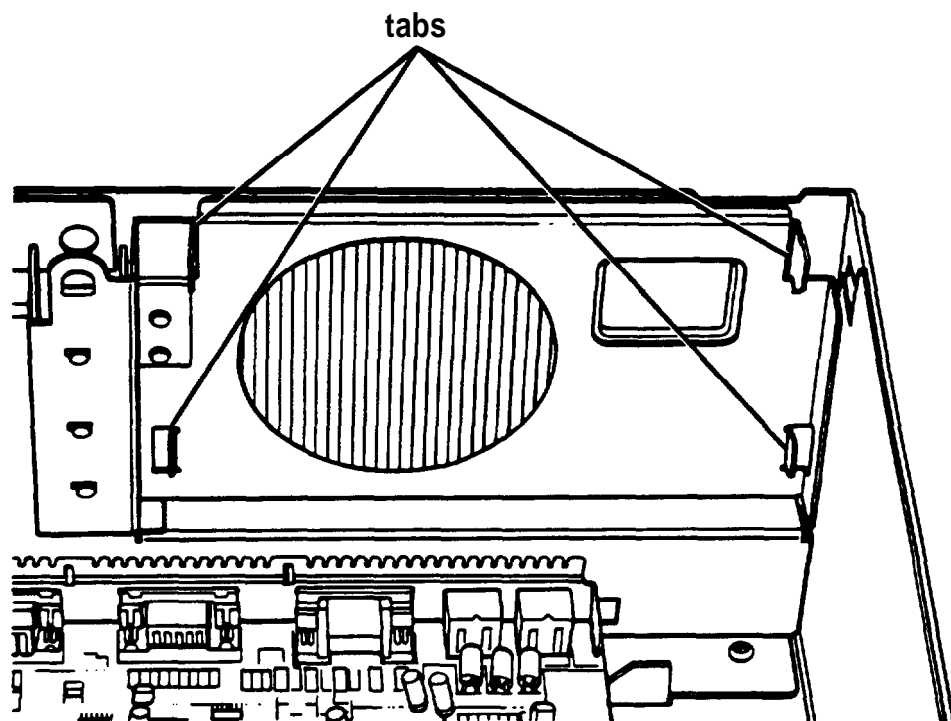



2. Lift up the subassembly from your work surface and lower the back end into the computer, fitting the top tabs in the computer into the openings in the top dots on the subassembly, as shown below.

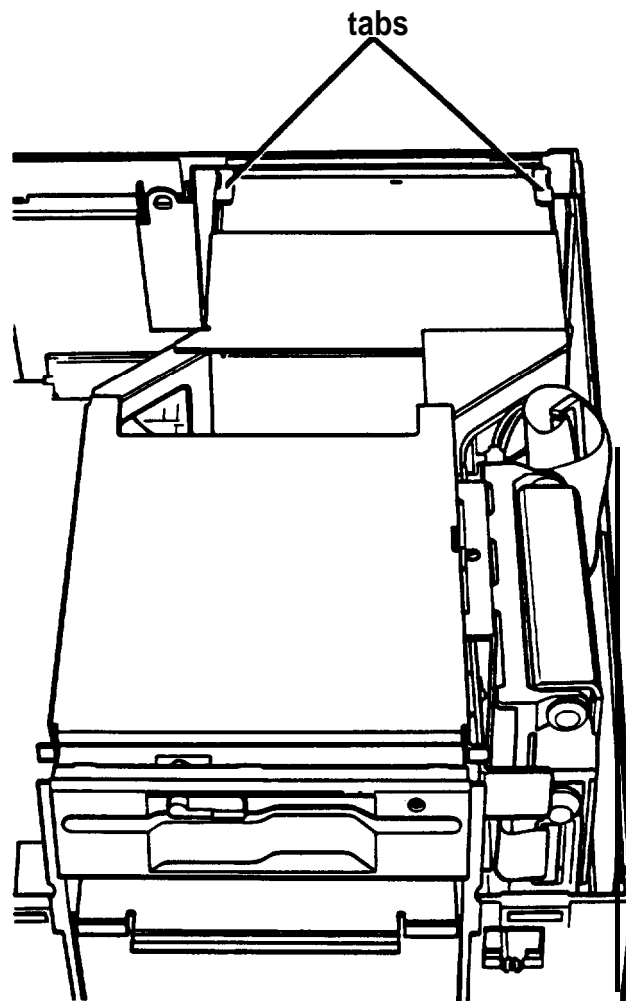

The subassembly is actually resting on the top tabs.

3. Hold up the subassembly at an angle. Reach under it and grasp the two main system board power supply cables leading from the power supply. The cables are labelled P4 and P5.

Each connector has six pin holes and a large tab on one side, as shown below.

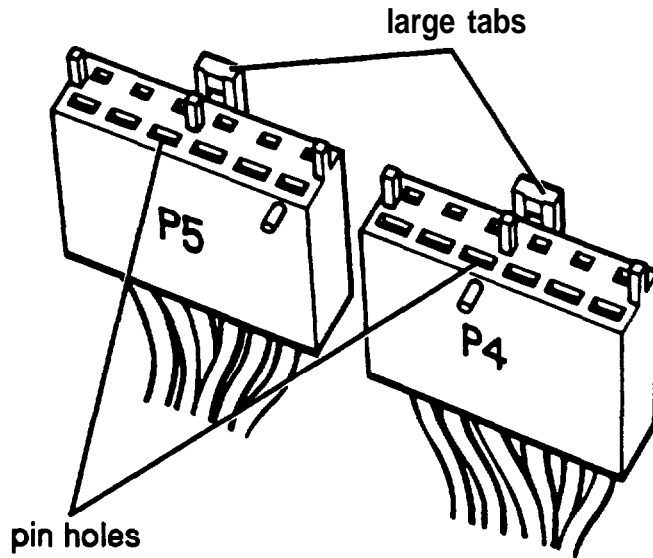

The one 12-pin power supply socket (shown below) on the right side of the main system board (toward the back) holds both of the power supply connectors.

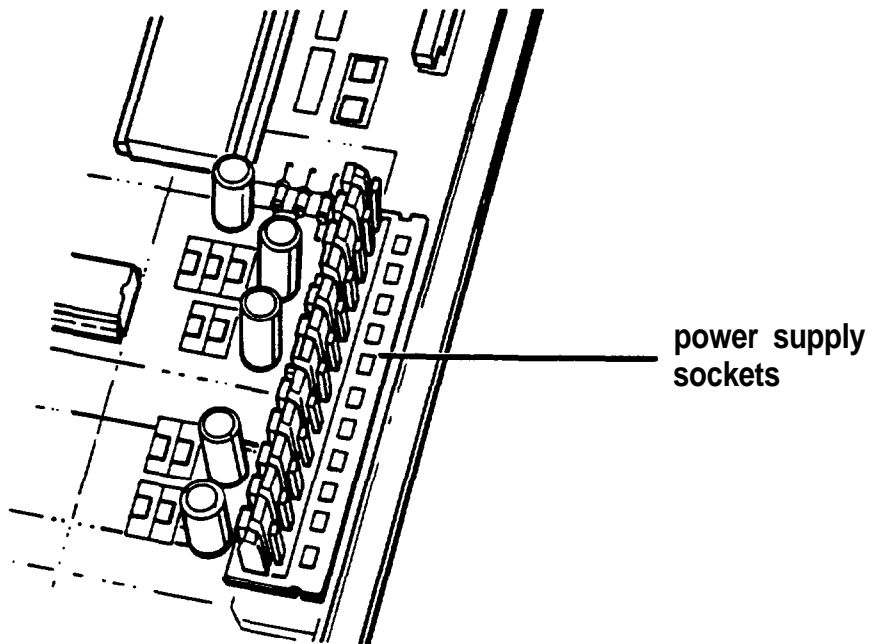

4. Position power supply connector P4 so the large tab on the connector faces the right side of the computer. Beginning with the six pins toward the back of the computer, carefully line up the large pin holes in the connector with the metal pins in the socket. Make sure the holes fit over all six pins and then push the connector onto the pins.

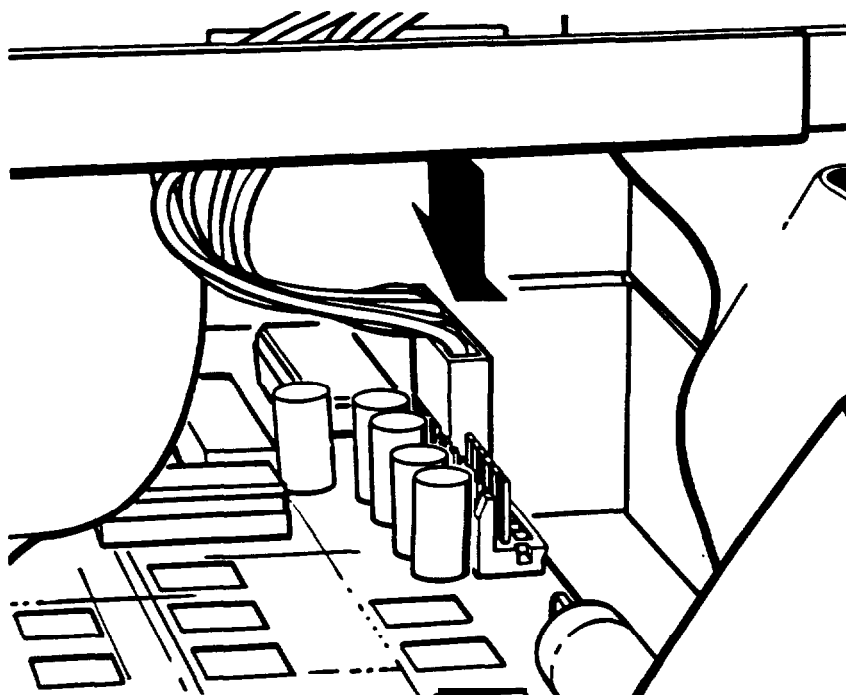

### caution

If you do not correctly align the holes with the pins in the socket, you could severely damage your computer when you push in the connector,

5. Connect power supply connector P5 to the remaining six pins in the socket using the same procedure.
6. Still holding up the front of the subassembly, arrange the ribbon cables leading from the back of the drives underneath the subassembly. The hard disk drive cable may be attached to the bottom of the subassembly.

7. Determine which cable is the hard disk drive cable and which is the diskette drive cable.

Both the diskette drive and hard disk drive sockets on the main system board have a notch on one side. The hard disk drive socket is closest to the front of the main system board and the diskette drive socket is behind it.

8. Connect the diskette drive cable first. As shown below, there is a tab on one side of the connector.

diskette drive connector

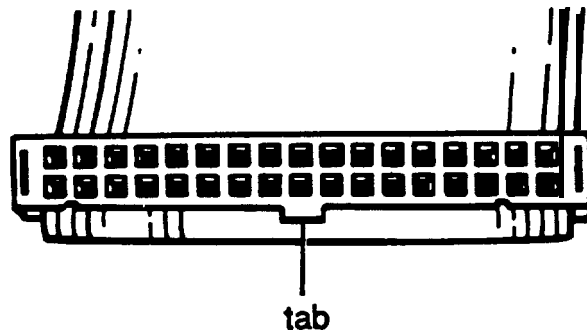

diskette drive socket

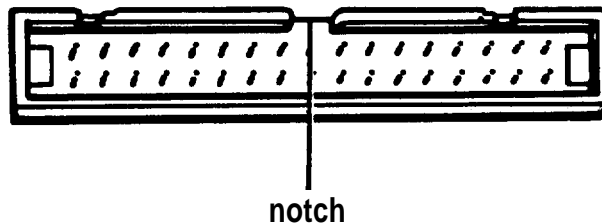

Align the connector with the socket so the tab on the connector lines up with the notch in the socket. Make sure the holes in the connector fit over all the pins in the socket and then push in the connector.

### **Caution**

If you do not correctly align the holes with the pins, you could severely damage your computer when you push in the connector.

9. Now connect the hard disk drive cable in the same manner.
10. Carefully lower the front of the subassembly onto the computer. Make sure that all four tabs on the back of the computer are inserted into the slots on the subassembly as you lower it.
11. Guide the tabs on the front of the subassembly over the opening in the front of the computer so the two small tabs sit behind the opening and the large tab with the curved lip sits over the front of the opening. If necessary, press on the large tab until the subassembly snaps into place.

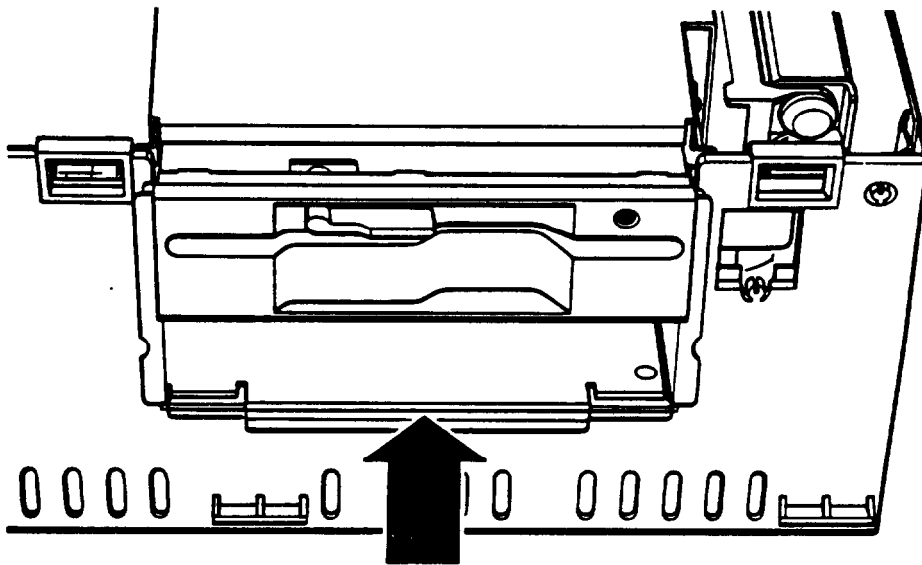

12. To replace the front panel, fit the three ridged tabs on its bottom edge into the three notches on the lower edge of the computer, as shown below.

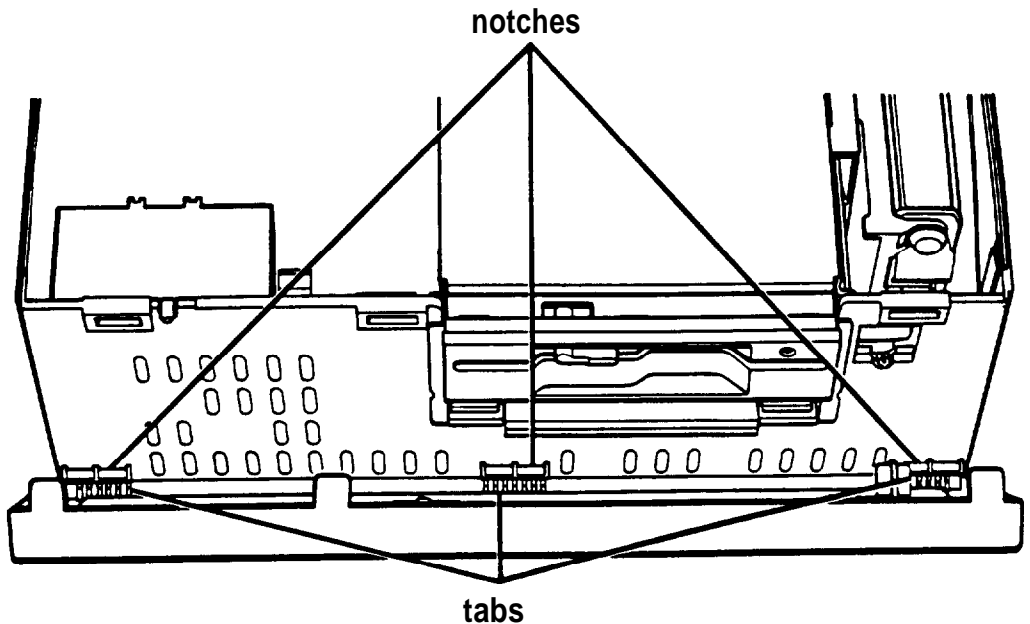

#### Note

If you installed a diskette drive in the horizontal drive bay, you need to remove the slot cover from the front panel. Use a screwdriver to remove the two screws that secure the slot cover to the panel. Store the screws and the slot cover in a safe place.

If you removed a diskette drive from the horizontal drive bay, you need to replace the slot cover in the front panel.

13. Tilt up the front panel until the clips on the top of the panel touch the computer. Then push on the top of the panel until it clicks into place. The diskette drive(s) should be flush with the front panel.

---

## ***Replacing the Cover***

Follow these steps to replace the computer's cover:

1. Facing the back of the computer, hold the cover so that the side with three tabs on the edge points toward the front panel, as shown below.

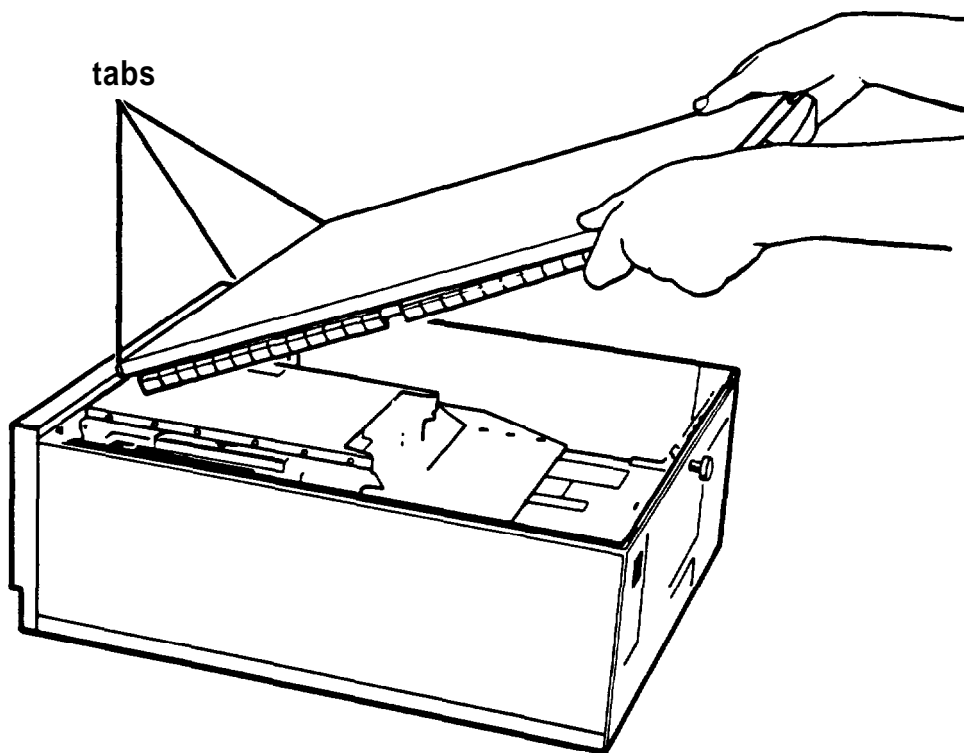

2. Insert the three tabs into the three notches in the back of the front panel of the computer.

3. Lower the back of the cover onto the computer and press down firmly on all edges to form a tight seal.

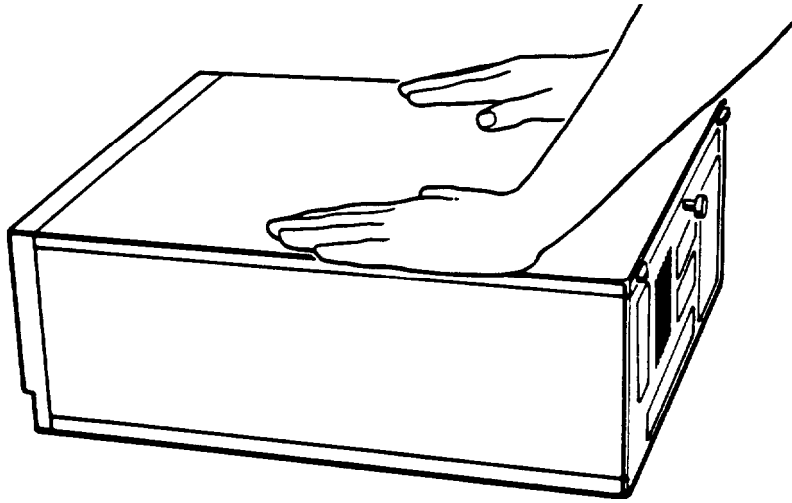

4. Turn the large screw on the back panel clockwise to secure the cover to the computer.
5. Reconnect the computer to the monitor, printer, keyboard, and any other peripheral devices you have.
6. Reconnect the power cable to the back of the computer and to an electrical outlet.



## ***Installing and Removing Options***

You can enhance the performance of your computer by adding a variety of options, including the following:

- ❑ Option cards
- ❑ Memory modules
- ❑ A math coprocessor.

An option card is a circuit board you install in your computer to add a particular function. Most option cards contain a device, such as a modem, or provide an interface, such as a connector to which you connect a monitor. This chapter describes how to install option cards and configure your computer for use with them.

Memory modules-also called SIMMs (single inline memory modules)-allow you to increase the amount of memory in your computer. This chapter describes the types and amounts of SIMMs you can use in your computer. If you want to install memory modules, it is best to ask your dealer to do it for you. You can, however, follow the instructions in this chapter to install them yourself.

### **Note**

It is best to add memory to your computer by installing SIMMs rather than an optional memory card. Using memory modules is more efficient because your computer can access memory installed on memory modules faster than memory installed on a card. Also, you do not need to use one of your options slots.

If you do install a memory card, it will slow the performance of your computer.

A math coprocessor speeds up the numeric calculations your computer performs when using certain application software. If *you* purchase a math coprocessor, it is a good idea to ask your dealer to install it for you, because it can be damaged easily. If you decide to install it yourself, follow the steps in this chapter.

This chapter also explains how to change the jumper settings inside the computer. You need to change jumper settings if you install certain types of options or want to change the way your computer operates.

Before you can change jumper settings or install any of the options mentioned above, you need to remove the cover from the computer. You also need to remove the subassembly that holds your disk drives inside the computer if you need to access the jumpers or the math coprocessor socket. See Chapter 5 for instructions. (You do not need to remove the subassembly to install option cards or memory modules.)

---

## ***Changing the Jumper Settings***

If you change your computer's configuration or need to alter the way it operates, you may need to change a jumper setting inside the computer.

A jumper is a small electrical connector that controls a computer function. The jumper settings in your computer are preset at the factory; however, you can control the features described in the following table by changing the standard settings.

## System board jumper settings

| Jumper number | Jumper setting | Function  |
|---------------|----------------|---|
| J1            | A'<br>B        | Color monitor is installed<br>Monochrome monitor is installed   |
| J2            | A'<br>B        | Enables the built-in VGA display adapter<br>Disables the built-in VGA display adapter so you can use a display adapter on an option card in your computer as your primary adapter |
| J3            | A'<br>B        | Enables the power-on password<br>Disables the power-on password   |

- Factory settings

The illustration below shows the locations of the jumpers on the main system board.

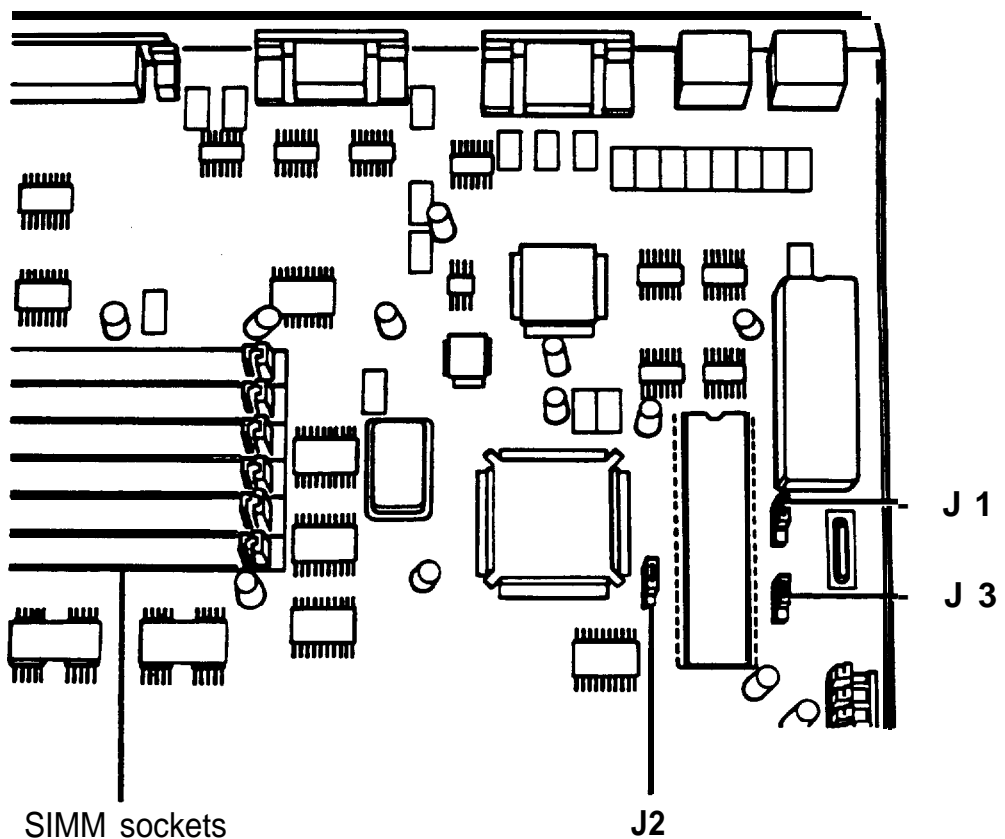

## ***Moving a Jumper***

A jumper's setting is determined by where the jumper is placed on the pins. The jumper either connects pin A and the middle pin (position A) or connects pin B and the middle pin (position B), as shown below. (The letters A and B are shown here for position only. They do not appear on the jumper.)

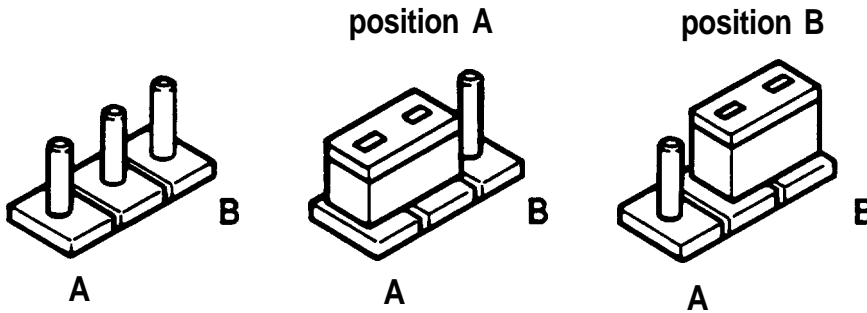

If you need to change any jumper settings, follow these steps:

1. If you have not already done so, remove the cover and the subassembly from the computer. See Chapter 5 for instructions.
2. To move a jumper from one position to the other, use needle-nose pliers or tweezers to pull it off its pins and gently move it to the desired position. Be careful not to lose the jumper.

### **Caution**

Take care not to bend the jumper pins or damage any surrounding components on the main system board.

3. Follow the instructions in Chapter 5 to replace the subassembly and the computer's cover.

---

## ***Installing an Option Card***

Your computer has four standard option slots: three 16-bit slots and one 8-bit access slot. Each slot can accommodate an option card. You can buy option cards from authorized Epson dealers as well as other vendors.

This section explains how to install option cards in your computer. Later on, you may want to remove an option card. If so, see “Removing an Option Card” later in this chapter for instructions.

### Note

After you install or remove an option card, see “Post-installation Setup” at the end of this chapter to configure your computer to operate with or without the option card.

The illustration below shows the four standard option slots inside your computer.

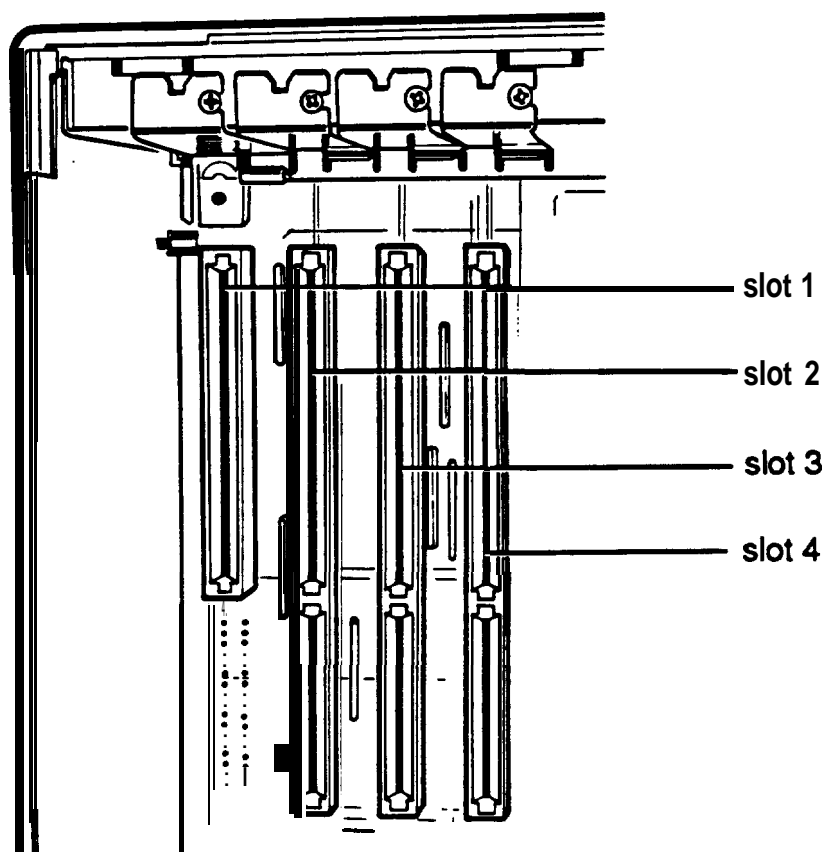

Slot 1 is designed for an 8-bit option card and slots 2 through 4 are designed for 16-bit cards. As you can see below, a 16-bit card has an extra connector along the bottom.

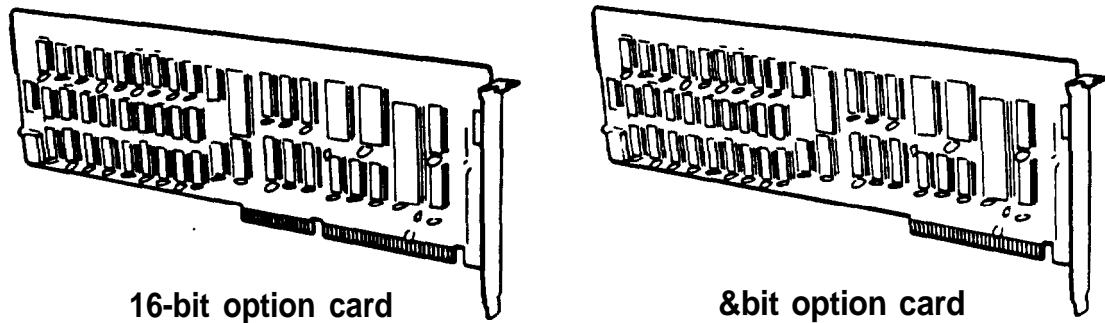

Usually it does not matter which slot an option card occupies as long as the card fits in the slot. For example, you can place some 8-bit cards in a 16-bit slot. However, you must follow these guidelines when deciding which slot to use:

- An 8-bit card with an additional tab along the bottom must go into an 8-bit slot.
- If you install a disk drive that uses a controller card, place the card as close as possible to the drive it is controlling.
- Some option cards must be installed in a specific slot. Consult the instructions that come with the card to see if this is the case.

Follow these steps to install an option card:

1. If you have not already done so, remove the cover from the computer. (See Chapter 5 for instructions.)

#### WARNING

After you remove the cover, touch the inside back panel of the computer to ground yourself and avoid an electric shock.

2. You do not need to remove the subassembly to install an option card. If you install a display adapter card, you may need to change the settings of jumpers J1 and J2. If this is the case, see page 6-2 for instructions.
3. Remove the retaining screw from the top of the metal option slot cover; hold on to the screw as you remove it so it doesn't fall into the computer. Lift out the slot cover.

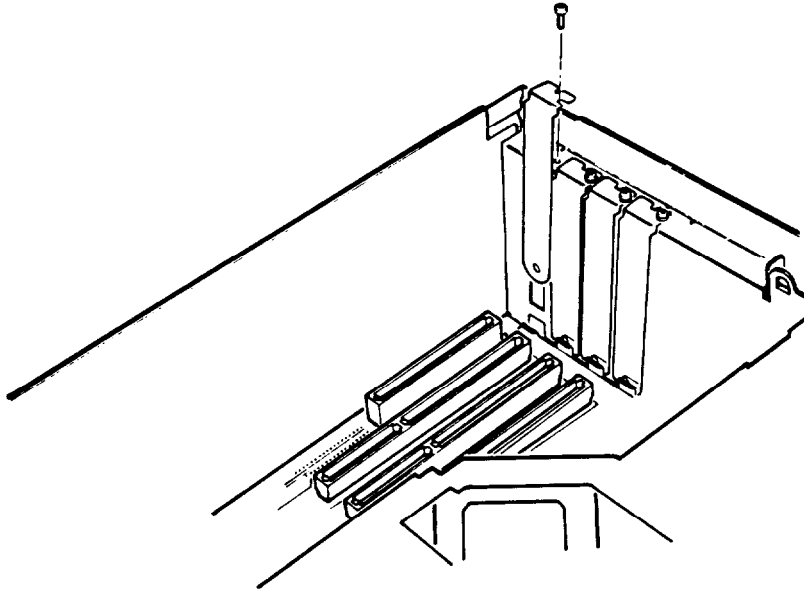

Keep the screw to secure the option card to the computer. Store the slot cover in a safe place in case you remove the option card later.

4. Unpack the option card and adjust any switches or jumpers on it, if necessary. (Check the option card instructions.) When you handle the card, be careful not to touch any of the components on the circuit board, especially the gold-edged connector pins. If you need to set it down before you install it, place it gently on top of its original packing material with the component side facing up. Keep the packing materials in case you remove the card later.

5. Grip the card firmly by the top corners and position it at the top of the slot, as shown below. Make sure the connector pins point down and the component side faces the power supply inside the computer.

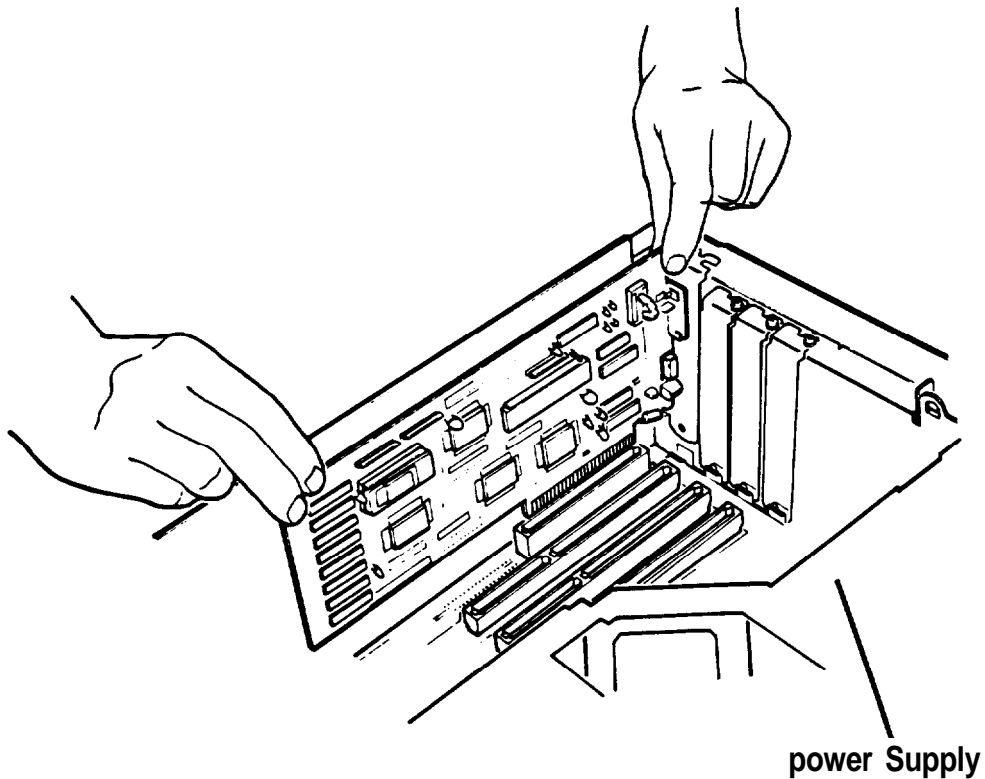

6. Insert the card into the slot, guiding it straight down. Once the connector pins reach the connector slot, push the card downward firmly (but carefully) to insert it fully. You should feel the card fit into place.

If the card does not go in smoothly, do not force it; pull it all the way out and try again, keeping it straight as you insert it. Examine the card to verify that it is fully seated in the slot along the length of the connector.



7. Secure the end of the card to the back of the computer with the retaining screw.

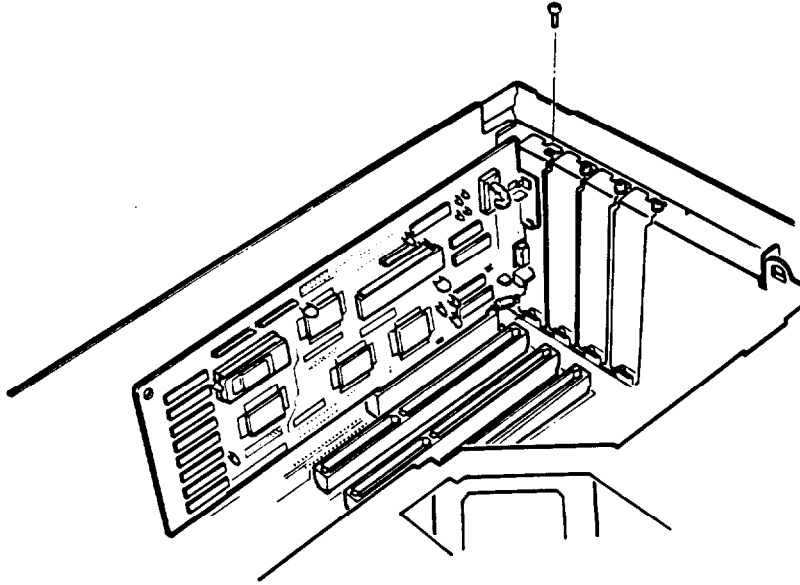

8. Follow the instructions in Chapter 5 to replace the cover.
9. See “Post-installation Setup” at the end of this chapter to configure your computer to operate with the option card.

---

## ***Removing an Option Card***

If you need to remove an option card, follow these steps:

1. First, remove the cover from the computer. See Chapter 5 for instructions.
2. Remove the screw securing the card to the back of the computer and pull it straight up and out of the slot. Either set the card aside by placing it gently on a soft surface with the component side facing up or carefully wrap the card, preferably with the original packing materials, and place it inside its box for safe storage.
3. Cover the end of the empty option slot with the original metal cover and secure it with the retaining screw.

4. If you are removing a display adapter card, you may need to change the settings of jumpers J1 and J2. See page 6-2 for instructions.
5. Replace the cover. See Chapter 5 for instructions.
6. See “Post-installation Setup” at the end of this chapter to configure your computer to operate without the option card.

---

## ***Adding Memory Modules***

Your computer comes with 2MB of memory. By installing SIMMs (single inline memory modules) on the main system board, you can increase the amount of on-board memory in your computer up to 14MB.

### **Caution**

It is best to have your dealer install memory modules for you because they can be damaged easily if installed incorrectly. If you prefer, you can install your own SIMMs by carefully following the instructions in this section. However, you could transmit an electrostatic discharge and damage your components; so read this entire section before you begin.

Before you install SIMMs, check the following guidelines to ensure that they will work properly:

- ❑ Use fast-page mode SIMMs that operate at 80ns (nanosecond) access speed (or faster). Be sure all the SIMMs have the same access speed.
- ❑ Use the correct SIMM configuration to add the amount of memory you want. See “Installing Memory Modules” on the next page.

Once you have the SIMMs you need, you or your dealer can install them in your computer. If you are going to install them yourself, follow the instructions below.

## ***Installing Memory Modules***

There are six SIMM sockets on the main system board organized in three banks consisting of two sockets each. Each socket can contain one SIMM.

You must fill the sockets in any bank you use with the same type of SIMM. The type of SIMMs you can install are 256KB, 1MB, or 4MB.

You can install SIMMs for a total of **12MB** of additional memory, which brings your system total to **14MB** of on-board memory. To install the maximum amount of on-board memory, you would install the following SIMMs in the three banks:



The following is another example of an additional memory configuration:



This configuration adds 4MB plus 512KB for a total 6MB plus 512KB of on-board memory.

### **Note**

When installing SIMMs, the only constraint is that you must install the same type of SIMM in both slots of a bank.

Follow these steps to install the memory modules:

1. Remove the computer's cover. See Chapter 5 for instructions. (YOU do not need to remove the subassembly.)
2. Turn the computer so that the back panel faces your left and the front panel faces your right. The SIMM sockets are located on the main system board just above the option slots, as shown below.

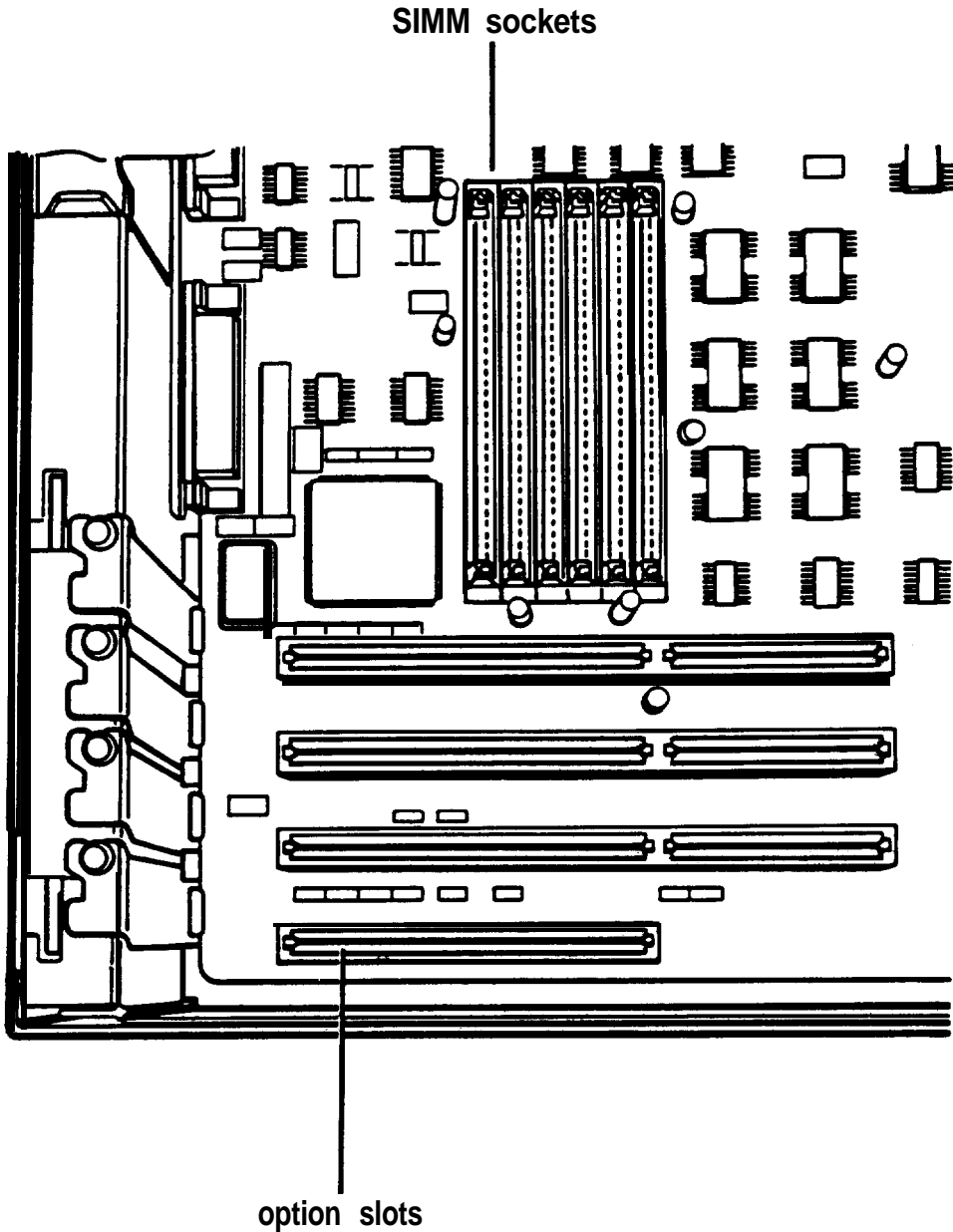

The sockets are labelled as shown below.

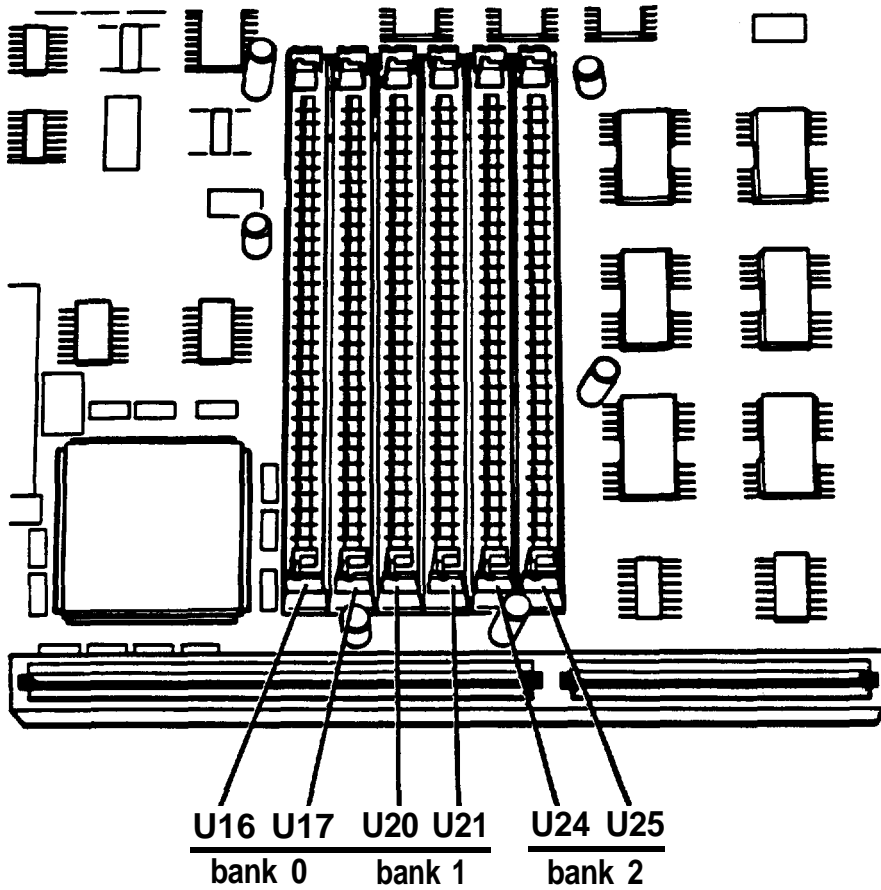

3. If an option card is blocking access to the SIMM sockets, follow the steps on page 6-9 to remove the card(s).
4. Hold the SIMM so the component side is facing to the left and the metal connector pins are facing down.

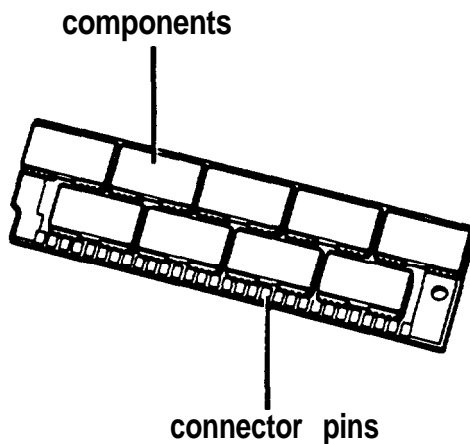

5. To insert the SIMM in the socket, place it on the right side of the tabs at an angle, as show below.

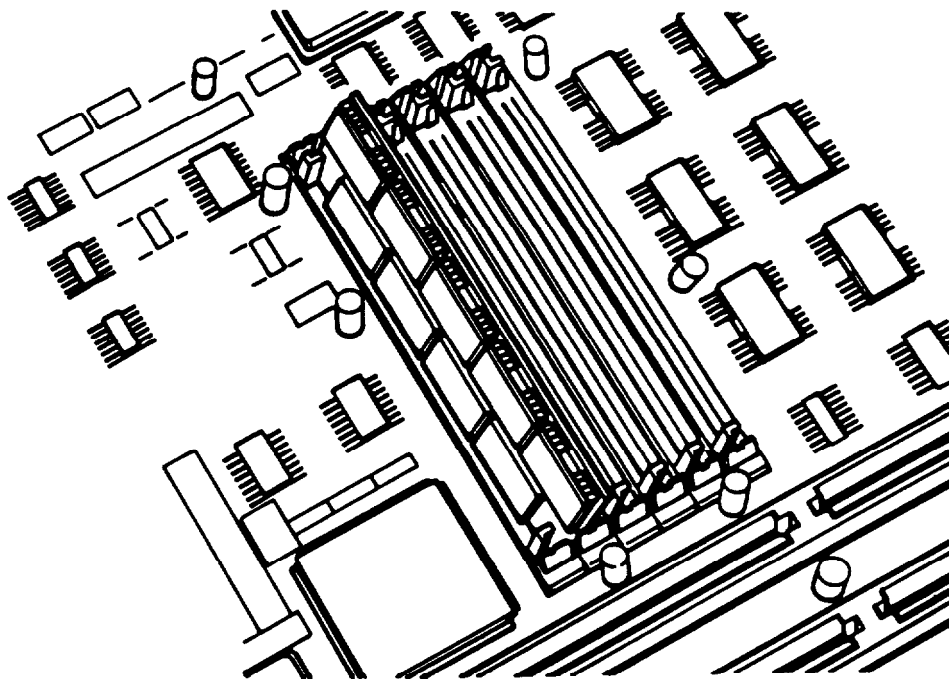

6. Gently push down on the SIMM and, at the same time, turn the top of the SIMM to the left until it is vertical and snaps into place between the tabs and the retaining posts.

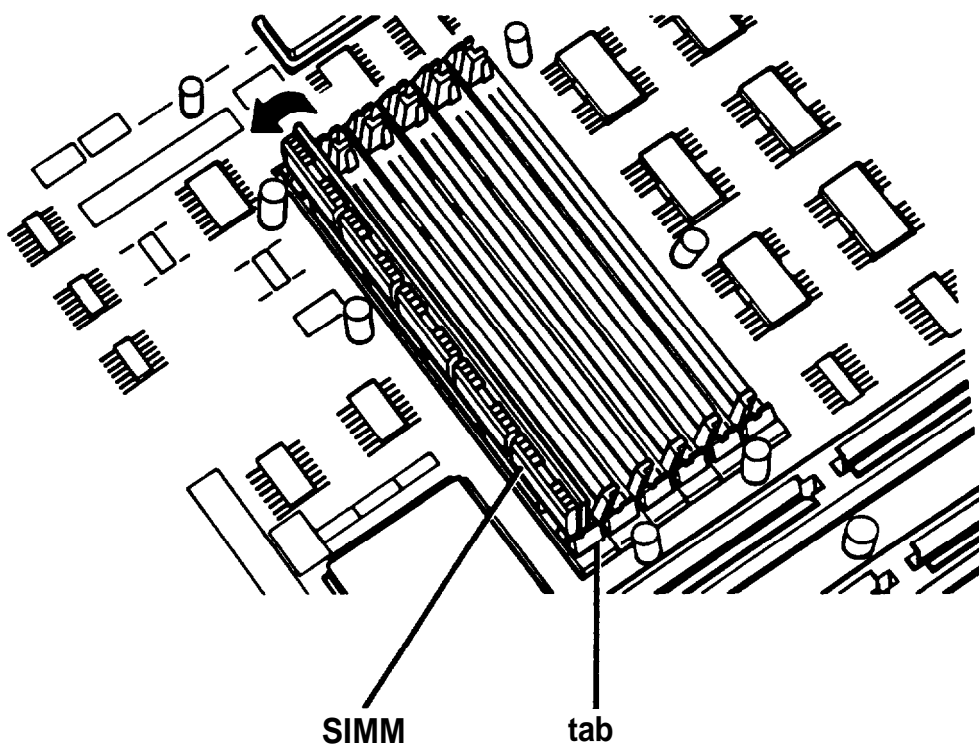

If the SIMM does not go in smoothly, do not force it; pull it all the way out and try again.

Make sure the SIMM is fully inserted into the socket and that the pins on the retaining posts protrude through the holes in both ends.

7. Repeat steps 5 and 6 for each SIMM you want to install.
8. Replace any option card(s) you may have removed to access the SIMM sockets. See “Installing an Option Card” on page 6-5 for instructions.
9. Follow the instructions in Chapter 5 to replace the computer’s cover.
10. See “Post-installation Setup” at the end of this chapter for instructions on configuring your computer for use with your new memory.

## ***Removing Memory Modules***

If you need to remove memory modules from your computer, have your dealer do it for you or follow the steps below. If you remove them yourself, remember that you must remove both SIMMs from a bank.

### **Caution**

It is safer to have your dealer remove SIMMs for you because there is a danger of transmitting an electrostatic discharge and damaging your components.

1. Remove the cover. See Chapter 5 for instructions.

2. Turn the computer so the back panel faces your left and the front panel faces your right. The SIMM sockets are located on the main system board above the option slots, as shown below.

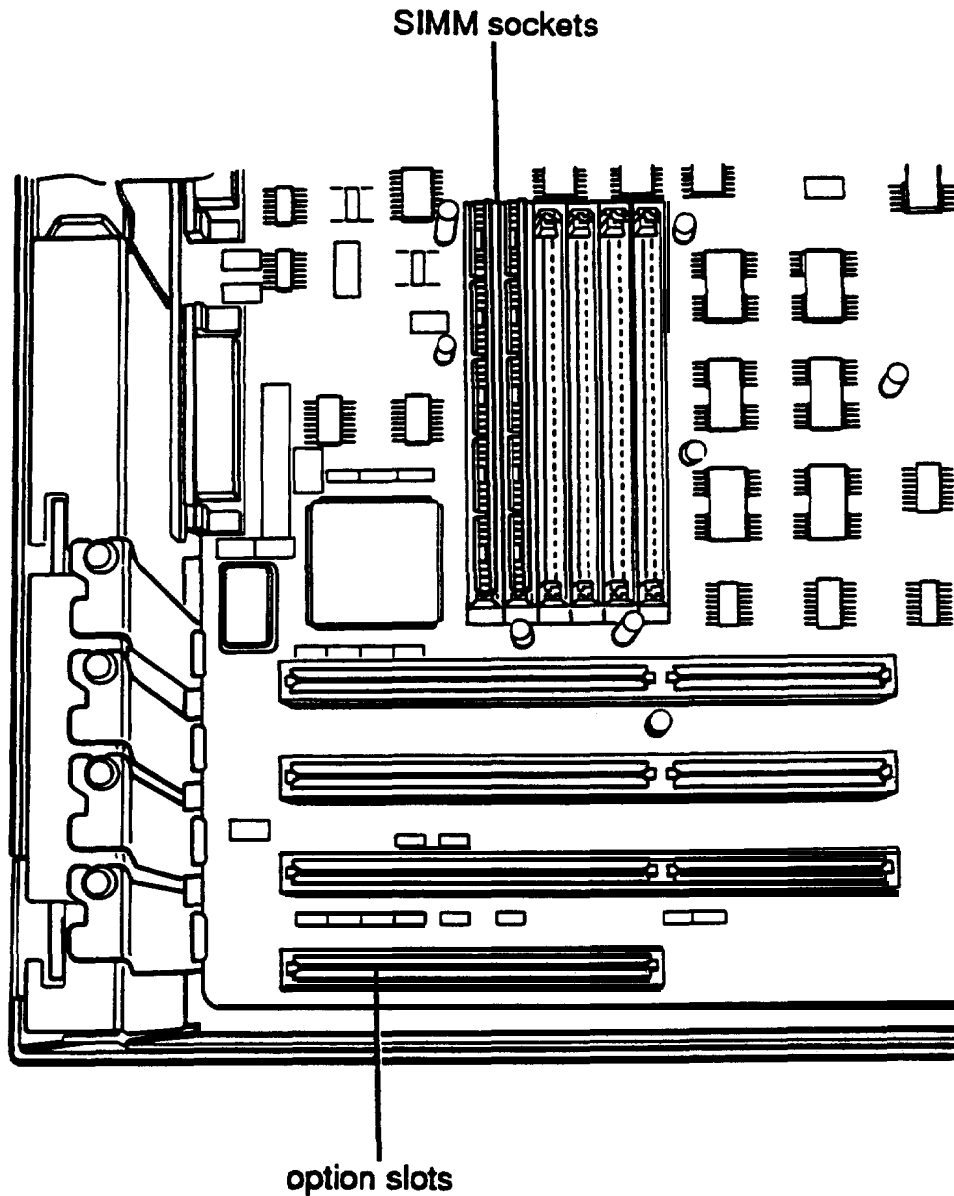



3. If an option card is blocking access to the SIMM sockets, follow the steps on page 6-9 to remove it.
4. Use your fingers or two small screwdrivers to pull away the tabs that secure the SIMM at each end. Be careful not to pull the tabs too far, or they may break.

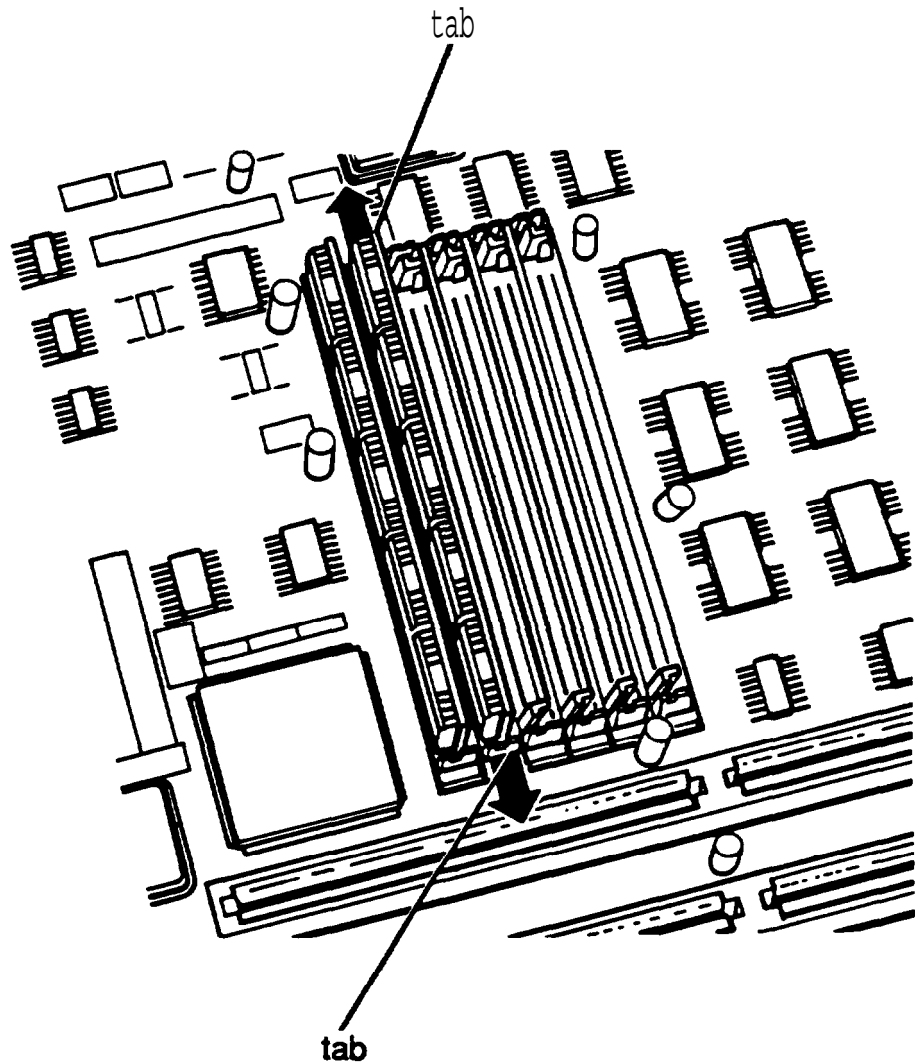

As you pull away the tabs, the SIMM falls to the right at an angle.

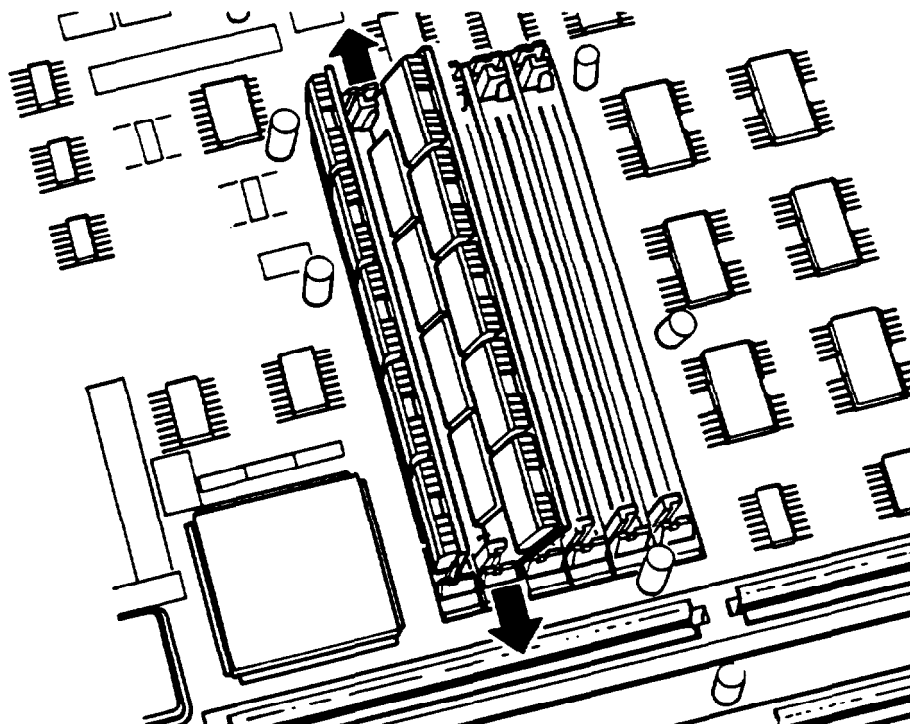

When the SIMM is at an angle, release the tabs and carefully remove it from the socket.

5. Repeat step 4 for each SIMM you need to remove.
6. Replace any option card(s) you may have removed to access the SIMM sockets. See “Installing an Option Card” on page 6-5 for instructions.
7. Follow the instructions in Chapter 5 to replace the computer’s cover.
8. See “Post-installation Setup” at the end of this chapter for instructions on configuring your computer for use with your decreased memory.

---

## ***Installing a Math Coprocessor***

Your computer has a socket on the main system board to accommodate an Intel 80387SX (20MHz) math coprocessor.

A math coprocessor speeds up the numeric calculations your computer performs when using certain application software. It also increases the speed at which graphic images are displayed on your monitor when you use graphics-oriented software.

It is best to have your dealer install a math coprocessor for you; it is a delicate component that can be damaged easily if it is installed incorrectly.

If you install it yourself, be sure to read the manual that came with your math coprocessor, if you received one. Then follow the steps in this section to install it in your computer. However, be sure to read all of the warnings and instructions carefully so you do not injure yourself or damage the coprocessor or your computer.

### **Caution**

To avoid generating static electricity and damaging your math coprocessor, remain stationary as you install it.

The math coprocessor socket is located on the front right side of the main system board, as shown below.

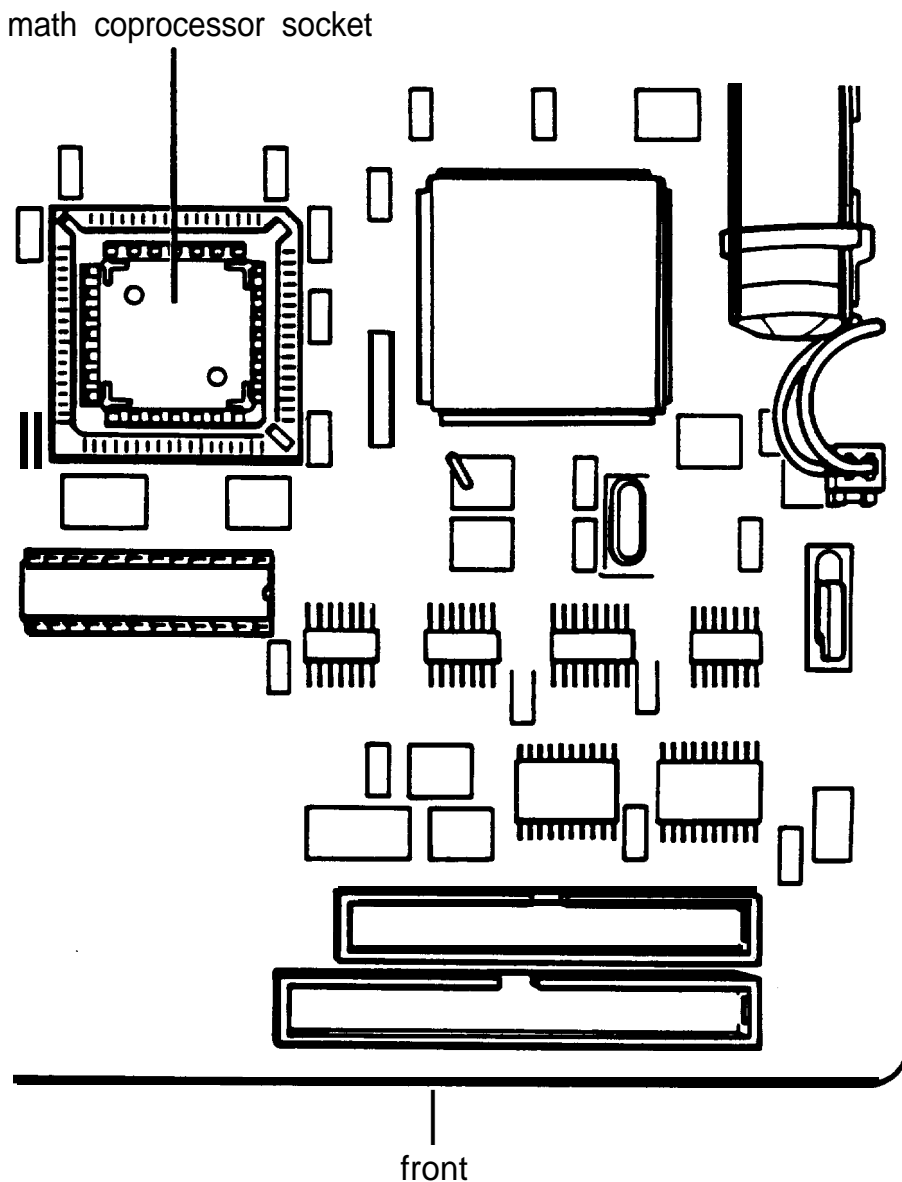

Carefully follow these steps to install an Intel 80387SX math coprocessor:

1. Remove the math coprocessor from its package and set it aside.
2. Remove the computer's cover and the subassembly. See Chapter 5 for instructions.

3. The math coprocessor socket is hollow and square. The upper right corner of the socket is notched, as shown below.

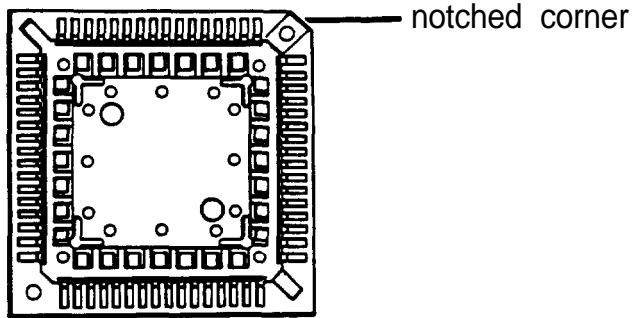

There is also a notched corner on the math coprocessor, as shown below.

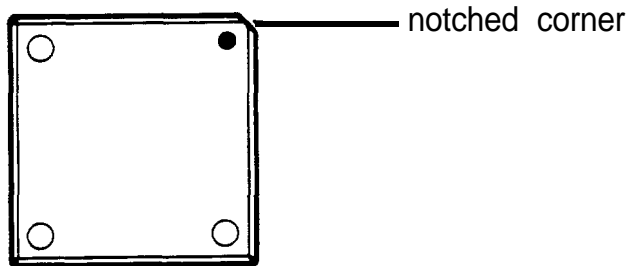

Align the notched corner of the coprocessor with the notched corner of its socket. The notched corners must be aligned for the coprocessor to fit into the socket, so be sure the alignment is correct before you proceed to the next step.

**Caution**

If you insert the math coprocessor in the wrong position, you could permanently damage it.

4. Gently push the coprocessor into the socket, pressing evenly on all sides of the coprocessor. If the coprocessor does not go in smoothly, do not force it; pull it all the way out and try again, keeping it straight as you insert it.

Examine the coprocessor to be sure it is inserted all the way into the socket.

5. Follow the instructions in Chapter 5 to replace the computer's subassembly and cover.
6. See "Post-installation Setup" at the end of this chapter for instructions on configuring your computer for use with your math coprocessor.

---

### ***Removing a Math Coprocessor***

If you need to remove a math coprocessor from your computer, contact your dealer for assistance. You need a special extracting tool to remove the coprocessor without damaging it. Do not attempt to remove it without this tool because you can easily damage it.

After you remove the coprocessor, run the Setup program on your Reference diskette to configure your system for use without it. See Chapter 2 for instructions.

---

## ***Post-installation Setup***

After you install or remove a math coprocessor or memory modules, you need to run the Setup program on your Reference diskette to automatically update the computer's configuration information. If you install or remove any other type of option, such as an option card or a disk drive, you must run Setup to update your settings. For example, if you add a hard disk drive, you need to let the computer know the type of drive you have installed. See Chapter 2 for instructions.

### Note

If you installed additional extended memory and want to use any of it as expanded memory, see "Using Expanded Memory Beyond 640KB" in Chapter 4 for more information.

If you install a hard disk drive that has never received a hardware level format (such as some non-Epson hard disk drives), you need to format the disk. Check the manual that came with your drive, and then, if necessary, follow the instructions in Appendix B to format your new hard disk.

If you have added a hard disk drive and you want to load MS-DOS or another operating system from that drive, you need to install the operating system on it. See your MS-DOS Installation Guide or the documentation that came with your operating system for instructions.

If you install a memory option card, use the setup program that came with it to configure the computer for use with the card. See your memory card manual for instructions.

Additionally, you may need to add some commands in your configuration files. See your MS-DOS Reference Manual and the manual that comes with your option card for instructions.

You may also want to test a newly-installed option. Some options come with their own diagnostics test programs, and you can test others with the diagnostics programs on your Reference diskette. You can use the System diagnostics program on your Reference diskette to test the following:

- System memory
- Math coprocessor
- Serial and parallel ports
- Disk drives
- Monitors and display adapters
- Dot-matrix printers.

See Appendix C for instructions.



## ***Installing and Removing Disk Drives***

This chapter describes how to do the following:

- ❑ Install a hard disk or diskette drive
- ❑ Remove a hard disk or diskette drive
- ❑ Change the hard disk drive jumper settings.

Your system can include up to three drives: either two diskette drives and one hard disk drive or one diskette drive and two hard disk drives. Your computer has two horizontal drive bays and one vertical mounting position to hold the drives, as shown below.

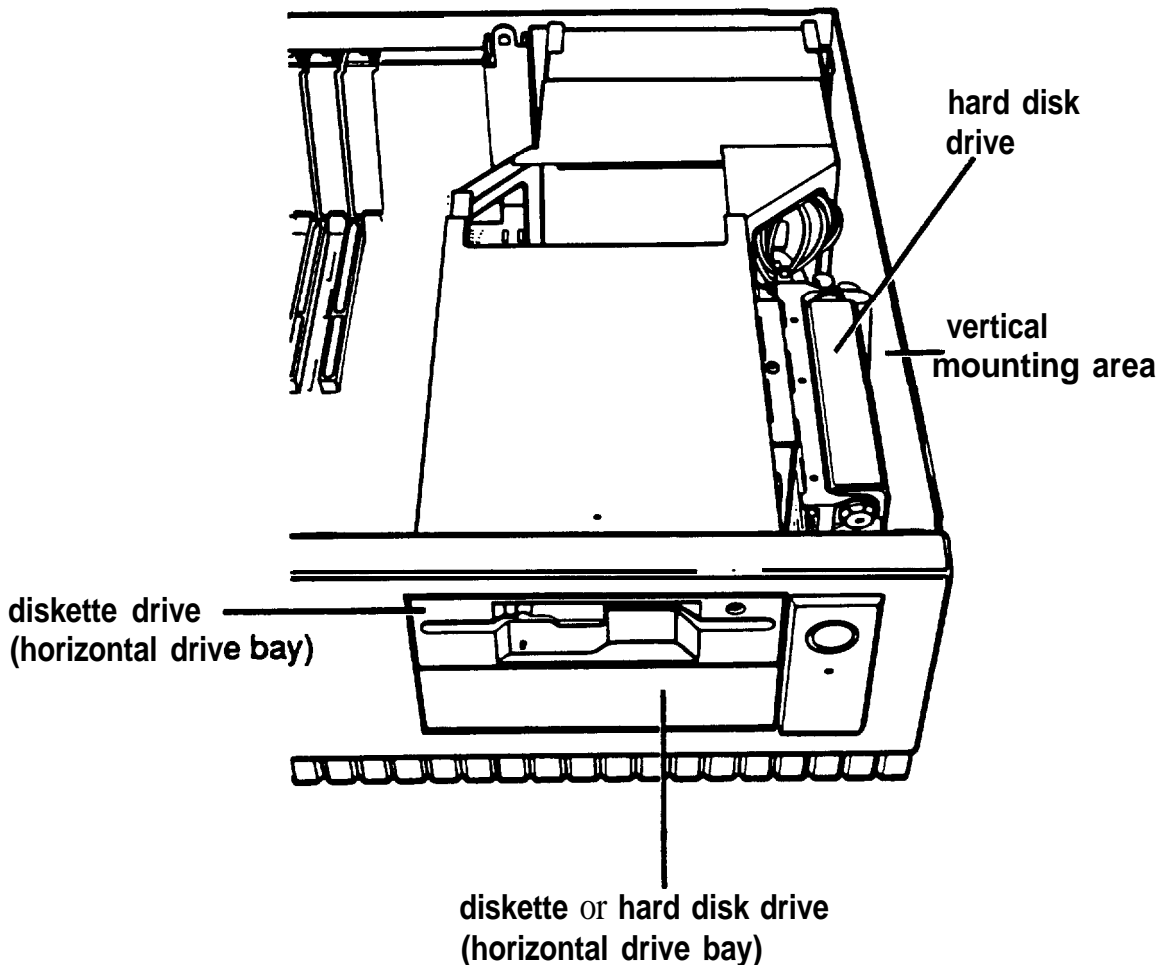

## **Caution**

Installing or removing a disk drive is a complicated procedure, so you may want to ask your dealer to do it for you. If you decide to do it yourself, you must carefully follow all the instructions in this chapter or you could damage your equipment.

---

## ***Using the Correct Drive Bay***

The upper horizontal drive bay probably contains the diskette drive that came with your system. That drive can be one of the following types:

- 5 1/4-inch** diskette drive
- 3 1/2-inch** diskette drive with a **5 1/4-inch** mounting frame installed on it.

You can install an additional drive of one of the following types in the lower horizontal drive bay:

- 5 1/4-inch** diskette drive
- 3 1/2-inch** diskette drive with a **5 1/4-inch** mounting frame installed on it
- 3 1/2-inch** hard disk drive with a pair of **5 1/4-inch** mounting frames installed on it.

Your computer may have come with a hard disk drive already installed in the vertical mounting position. If not, you can install one **3 1/2-inch** hard disk drive in this position.

If you are installing your first hard disk drive, it is best to install it in the vertical mounting position. If you add a second hard disk drive or diskette drive, use the lower horizontal drive bay.

---

## ***How to Use This Chapter***

The instructions in this chapter describe how to install and remove optional Epson diskette and hard disk drives. All drives sold by Epson for the Equity 386SX/20 PLUS are qualified and recommended for use in this system. Your drive may look a bit different from the one illustrated here, but you install it the same way.

If you are installing or removing a non-Epson drive, some of the steps may not apply to your drive; see the documentation that came with the drive for more information.

Each section in this chapter describes a part of the process you may need to perform. Here are the guidelines:

- ❑ Before you perform any of the procedures described here, follow the steps in Chapter 5 to remove the computer's cover and the subassembly.
- ❑ If you are installing a hard disk drive or removing one and leaving another in the computer, follow the steps under "Setting the Hard Disk Drive Jumpers" on page 7-4.
- ❑ If you are removing your only hard disk drive, see "Removing a Hard Disk from the Vertical Position" on page 7-21.
- ❑ If you are installing or removing a diskette drive and you currently have a hard disk drive installed in the vertical mounting position, see "Removing a Hard Disk from the Vertical Position" on page 7-21.
- ❑ If you are installing or removing a diskette drive and you do not have a hard disk drive installed in the vertical mounting position, see "Installing or Removing a Disk Drive in the Horizontal Position" on page 7-23.

- ❑ When you have finished accessing your drives, see the instructions in Chapter 5 to replace the subassembly and the computer's cover.

Additional instructions in each section tell you which steps to perform next.

---

## Setting the Hard Disk Drive Jumpers

You need to check or change the hard disk drive jumper settings if you install or remove any hard disk drives. The jumpers on the drive tell the computer whether you are using one hard disk drive or two.

### Note

You do not need to set these jumpers if you are removing your only hard disk drive.

If you remove one hard disk drive and leave another in your computer, you need to change the jumper settings on the remaining drive to indicate that you now have only one hard disk drive installed.

If you are installing your first hard disk drive and it is the only one you are going to install, see “Changing the Jumper Settings” on the next page to check the jumpers on your drive.

If you'll be using two hard disk drives, see “Setting the Jumpers for Two Hard Disk Drives,” below.

### ***Setting the Jumpers for Two Hard Disk Drives***

If you install two hard disk drives in your system, you must change the jumper settings on each drive to indicate which drive is the “master” drive and which is the “slave” drive.

A master drive is the drive on which you'll install the operating system that the computer loads into its memory each time you turn it on. You can run application programs and store data on both the master drive and the slave drive, but the master drive must contain the operating system.

Follow the instructions in the next section to change the jumper settings on both of your hard disk drives.

### ***Changing the Jumper Settings***

The hard disk drive jumpers are located on the drive's circuit board, near the large cable connector.

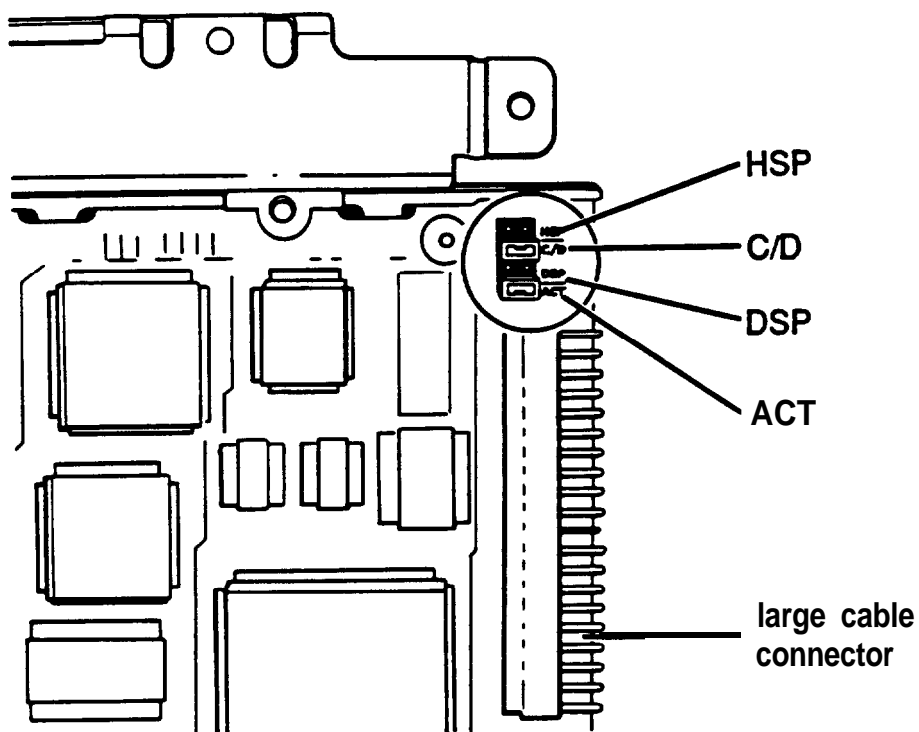

The jumpers on your drive may be in a slightly different location, but you set them the same way.

The following table lists the jumper settings for all the possible hard disk drive configurations.

### Hard disk drive jumper *settings*

| Jumper positions | Drive configurations |                              |                             |
|------------------|----------------------|------------------------------|-----------------------------|
|                  | One hard disk drive  | Two hard disk drives: master | Two hard disk drives: slave |
| HSP              | -                    | -                            | -                           |
| C/D              | X                    | X                            | -                           |
| DSP              | -                    | X                            | -                           |
| ACT              | X                    | X                            | X                           |

X = jumper installed  
- = no jumper installed

To move a jumper from one position to the other, use your fingers, needle-nose pliers, or tweezers to pull it off its pins and gently move it to the other position. Be careful not to drop the jumper or damage the pins as you install it.

If you are going to use only one hard disk drive, the jumpers should be set in positions C/D and ACT. If necessary, change them to these settings. Then see “Installing a Hard Disk in the Vertical Position,” on page 7-7 for instructions on installing your first hard disk drive.

If you’ll be using two hard disk drives, you have a total of four jumpers for eight jumper positions. (Two jumpers are included with each drive, and each drive has four positions.) Install three of the jumpers on the master drive in positions C/D, DSP, and ACT. Install the fourth jumper on the slave drive in position ACT.

If you are installing two hard disk drives at one time, install the drive in the horizontal drive bay first. See “Installing or Removing a Disk Drive in the Horizontal Position,” on page 7-23 for instructions.

If one of your hard disk drives is already installed in the computer, follow the steps under “Removing a Hard Disk From the Vertical Position,, on page 7-21 to remove it. Then set the jumpers on both drives while they are out of the computer.

#### Note

If you are removing one hard disk drive and leaving one in your computer, be sure to set the jumpers on the remaining drive to indicate that you have only one hard disk drive. See the table above for the correct jumper settings. Then follow the instructions under ‘Removing a Hard Disk From the Vertical Position,, on page 7-21 so you can access the jumpers on the drive.

---

## ***Installing a Hard Disk in the Vertical Position***

Follow the instructions in this section to install (or reinstall) a hard disk drive in the vertical mounting position. You may need to perform the following procedures:

- Removing the mounting frames from a new hard disk drive
- Removing the mounting plate from the computer and connecting it to the drive
- Installing the drive
- Attaching the drive cable to the bottom of the subassembly.

If you are installing a new drive in the vertical mounting position, follow all of the steps in this section. If you are reinstalling a drive that you previously removed from this position, see “Installing the Drive” on page 7-12.

## ***Removing the Mounting Frames From the Drive***

Your hard disk drive comes with 5 <sup>1</sup>/<sub>4</sub>-inch mounting frames attached to each side of the hard disk drive, as shown below.

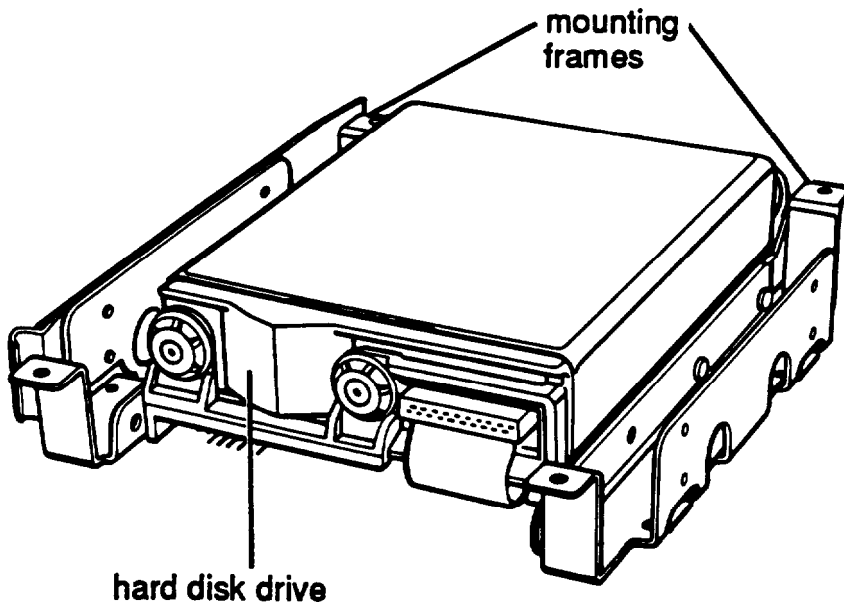

There may be a plastic guide rail on one side. Follow these steps to remove the mounting frames (and guide rail) from the drive:

1. If necessary, remove the screws securing the plastic guide rail and the metal grounding plate to the one mounting frame.

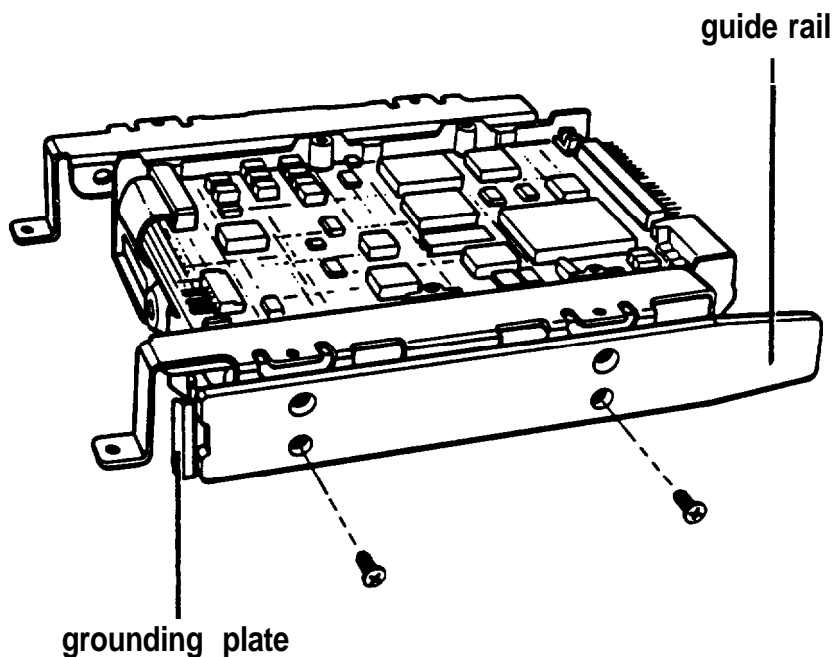



2. Remove the four screws securing the mounting frames to the hard disk drive. There are two screws securing each frame, as shown below.

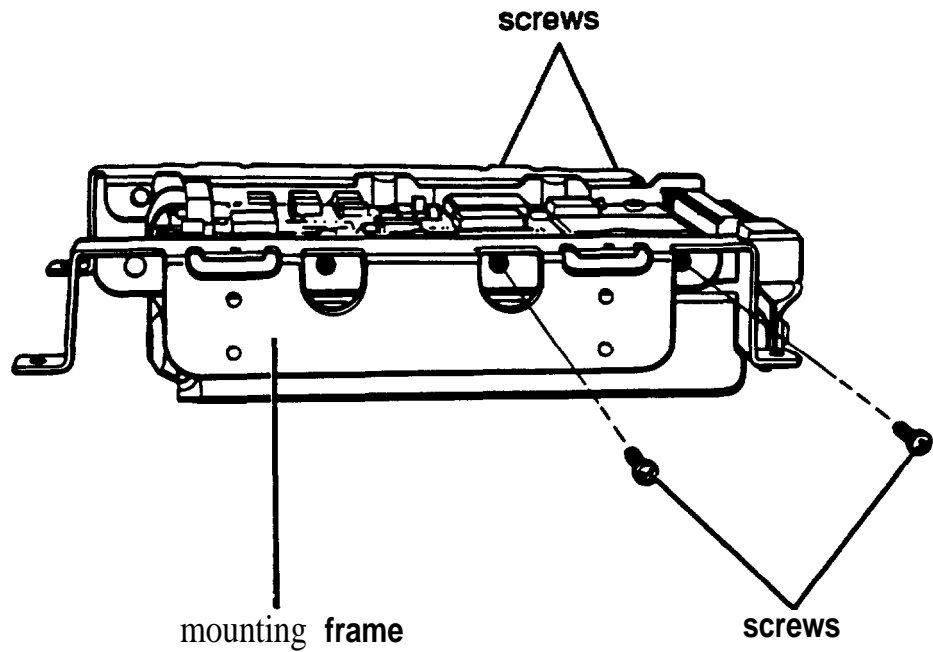

Keep the four screws so you can use them to secure the mounting plate to the hard disk drive. Then set the drive aside with the component side facing up.

## ***Removing and Attaching the Mounting Plate***

If you are installing a new hard disk drive in your computer, you need to attach a hard disk drive mounting plate to the drive. This mounting plate is currently attached to the side of the subassembly, as shown below.

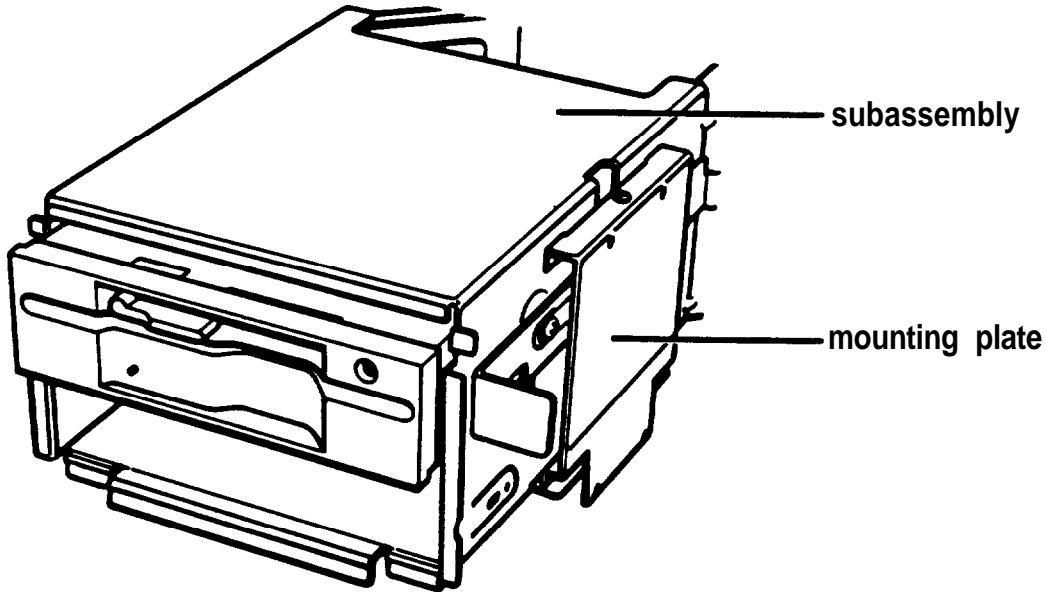

Follow these steps to remove the mounting plate from your computer:

1. Turn the subassembly so that the front panel area is facing you. The vertical mounting area is located on the right side of the subassembly.
2. Using a screwdriver, remove the screw securing the mounting plate to the subassembly and set it aside. Then lift up the mounting plate to remove it.

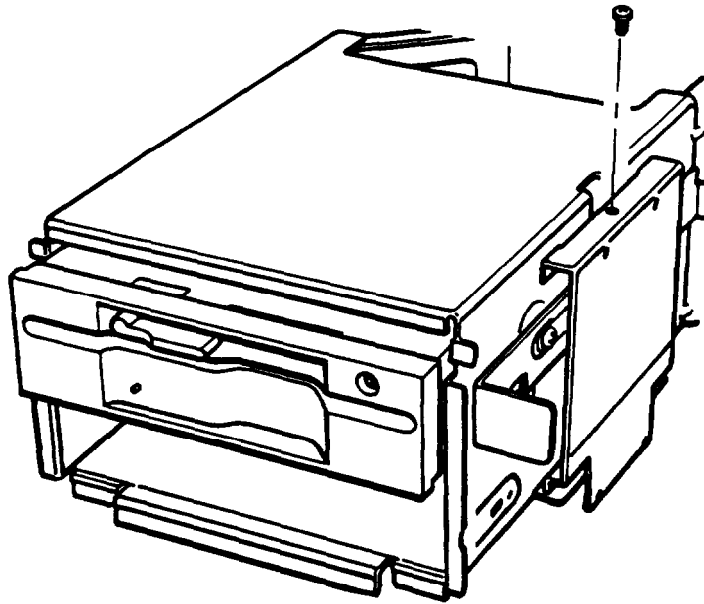

3. Turn your hard disk drive so the components are facing up and the connectors at the back of the drive are facing your right.
4. Place the flat side of the mounting plate on the hard disk drive, as shown below.

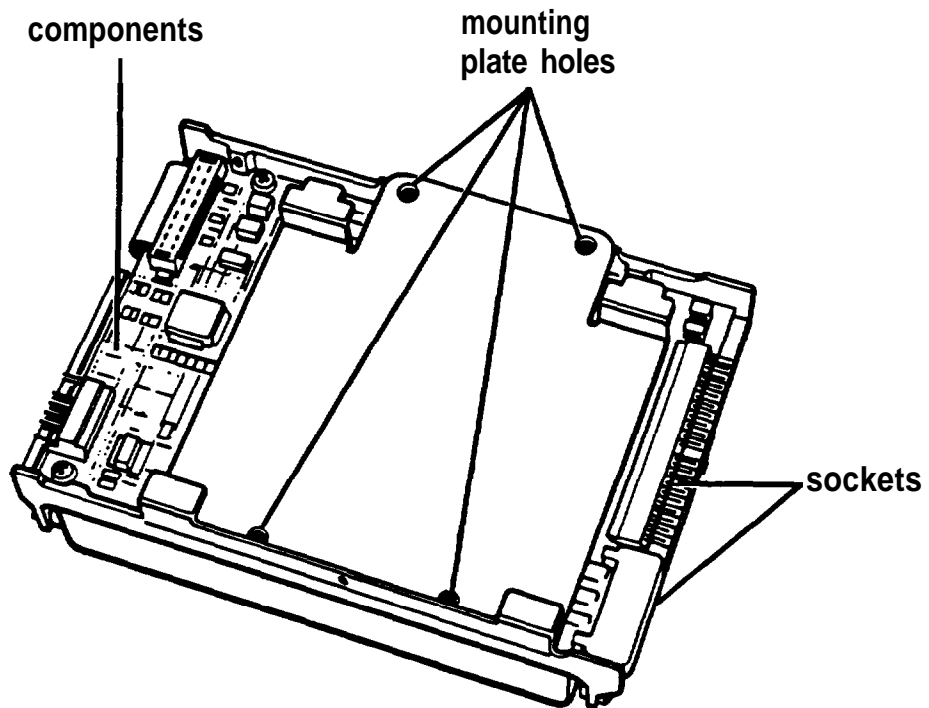

5. Align the four holes on the mounting plate with the four holes on the bottom of the hard disk drive.
6. Locate the four screws that you removed from the 5 1/4-inch mounting frames and use them to secure the mounting plate to the hard disk drive.

## ***Installing the Drive***

If you are going to install or remove a drive in one of the horizontal drive bays, first follow the instructions under “Installing or Removing a Disk Drive in the Horizontal Position,” on page 7-23. Do not install the vertically mounted hard disk drive until you are finished accessing the horizontal drives.

Follow these steps to install the hard disk drive in the vertical mounting position:

1. Place the hard disk drive on the right side of the subassembly with the mounting plate facing up and the ribbon cable and power supply sockets facing the back of the subassembly.

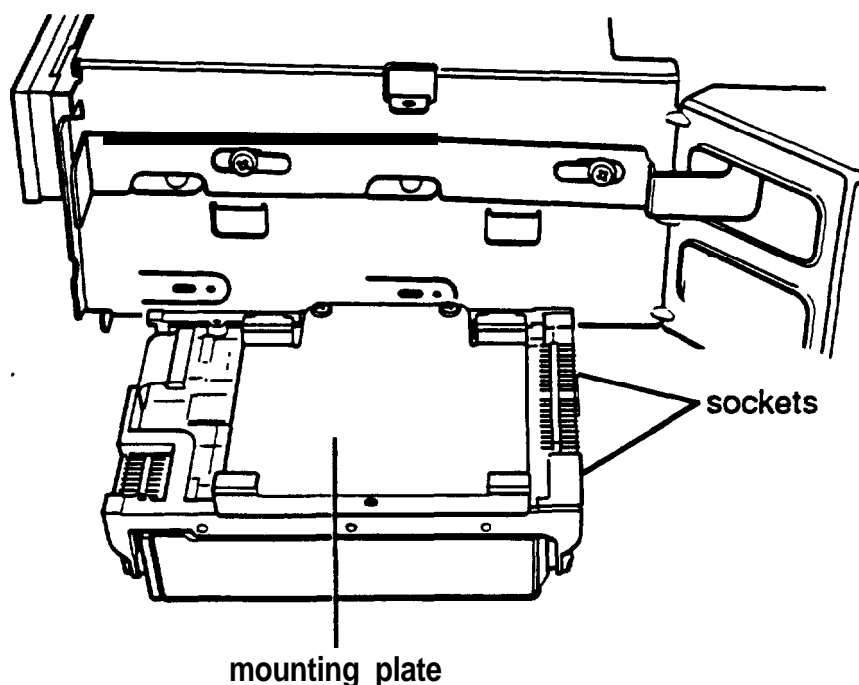

2. Locate the hard disk drive ribbon cable that came in the box with your computer. It is a flat, folded cable with three connectors. (If you are reinstalling a hard disk drive, the ribbon cable is arranged under the subassembly.)

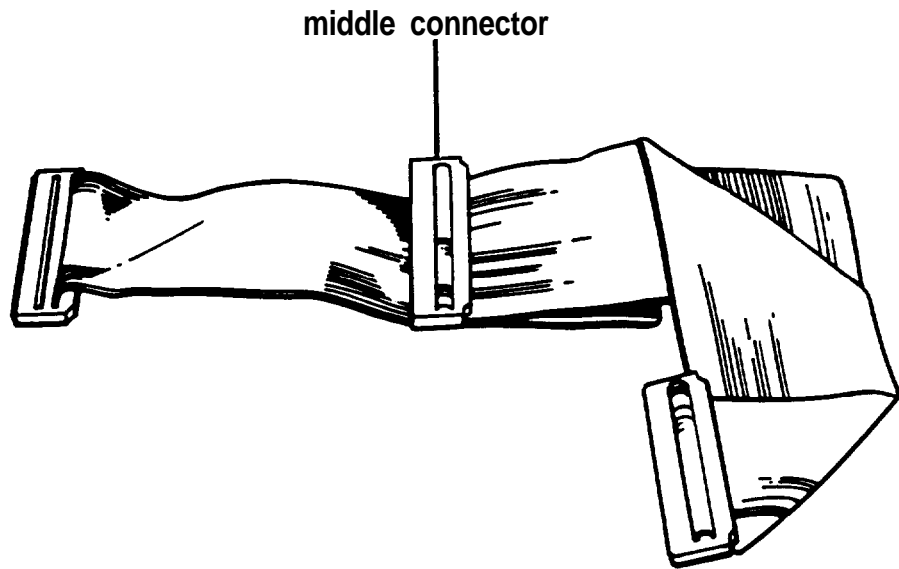

Use the connector in the middle of the cable, indicated in the illustration above.

As shown below, there are two rows of holes in the end of the connector. One of the holes is blocked with a plug.

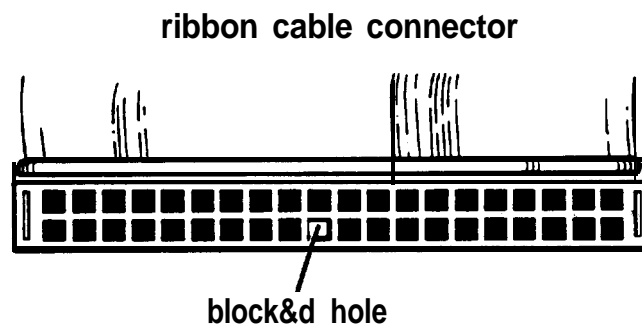

The ribbon cable socket on the back of the drive has two rows of pins. In one of the rows, a pin is missing.

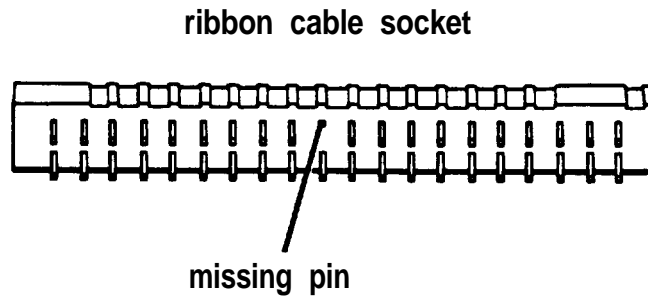

3. Align the connector with the socket so that the row in the connector with the blocked hole lines up with the row in the socket with the missing pin.

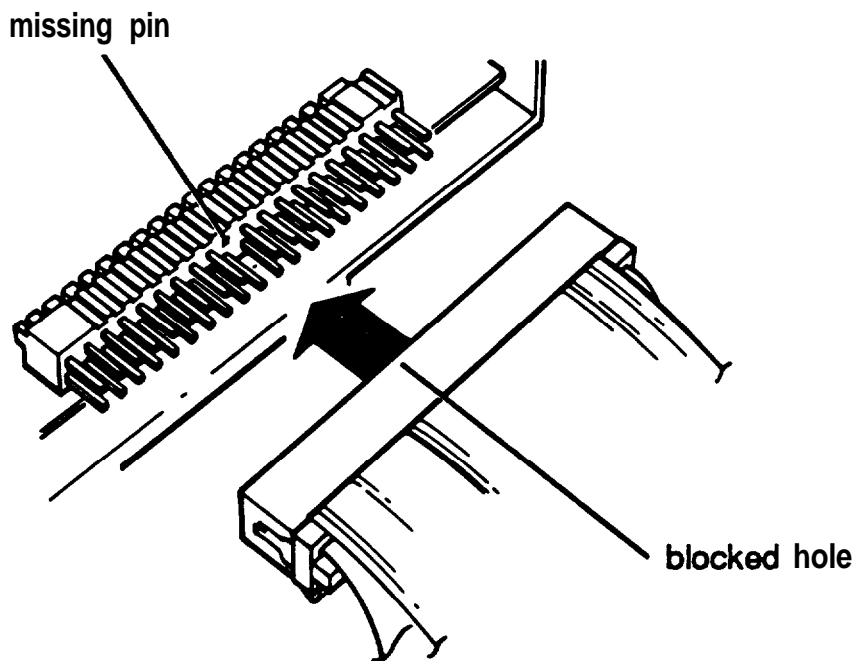

Make sure the holes fit over all the pins and then push the connector onto the pins.

### **Caution**

If you do not correctly align the holes with the pins, you could severely damage your hard disk drive when you push in the connector.

4. Locate one of the power supply cables that lead from the power supply in the computer (behind the horizontal drive bays). The cables are labelled P1, P2, or P3 and have a clear plastic connector on one end. One cable is already attached to the diskette drive; you can use either of the remaining two cables. As shown below, the end of the connector has two notched comers.

power supply cable

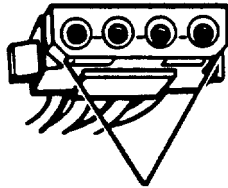

notched corners

power supply socket

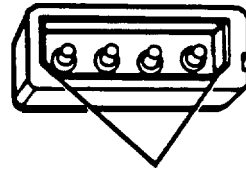

notched corners

The power supply socket is on the back of the hard disk drive, next to the ribbon cable you just connected. The socket also has two notched comers, as shown above.

Pulling the power supply cable through the lower opening on the right side of the subassembly makes it easier to reach the socket on the drive.

5. Line up the connector with the socket so that the notched corners are aligned.

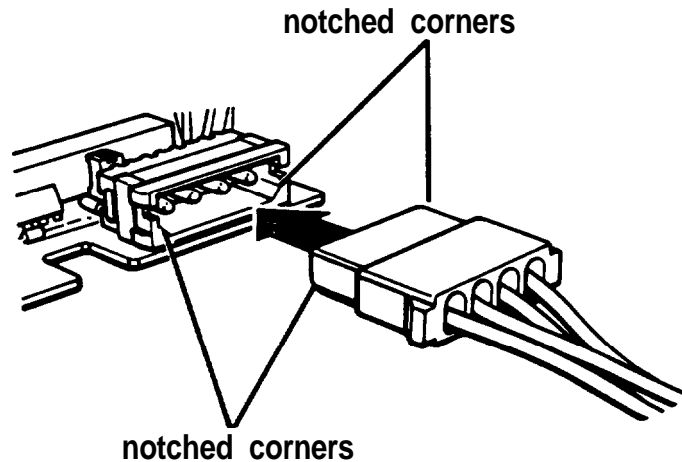

Make sure the holes fit over all the pins **and** then push the connector into the socket.

#### Caution

If you do not correctly align the holes with the pins, you could severely damage your hard disk drive when you push in the connector.



- Pick up the hard disk drive and hold it so the mounting plate is facing the subassembly, as shown below.

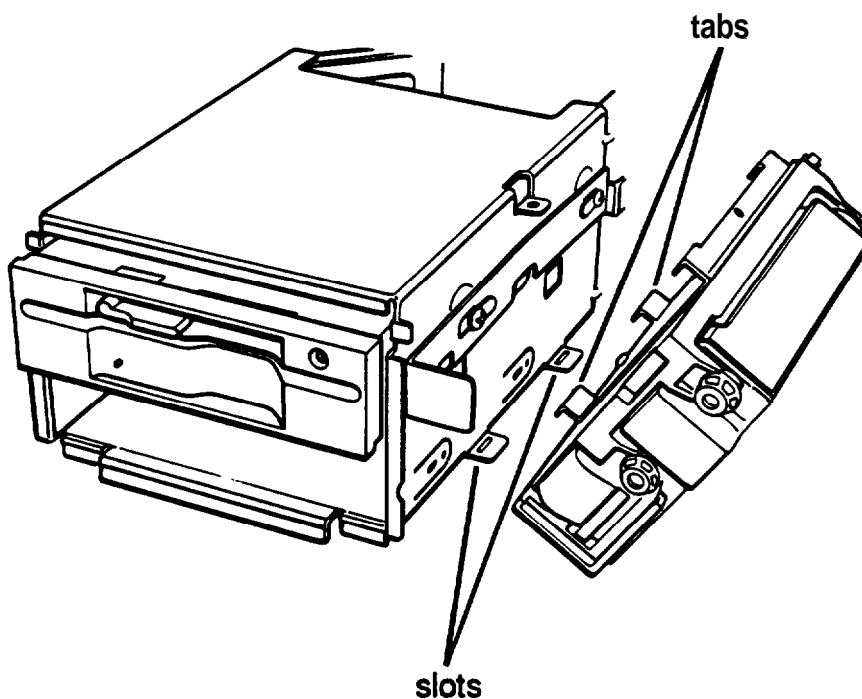

Notice that there are two tabs facing downward on the bottom of the mounting plate. These tabs will fit into two slots in the right side of the subassembly.

7. Hold the subassembly up slightly as you **lower** the **drive** onto it. Keep the cables to the **right** of the drive.

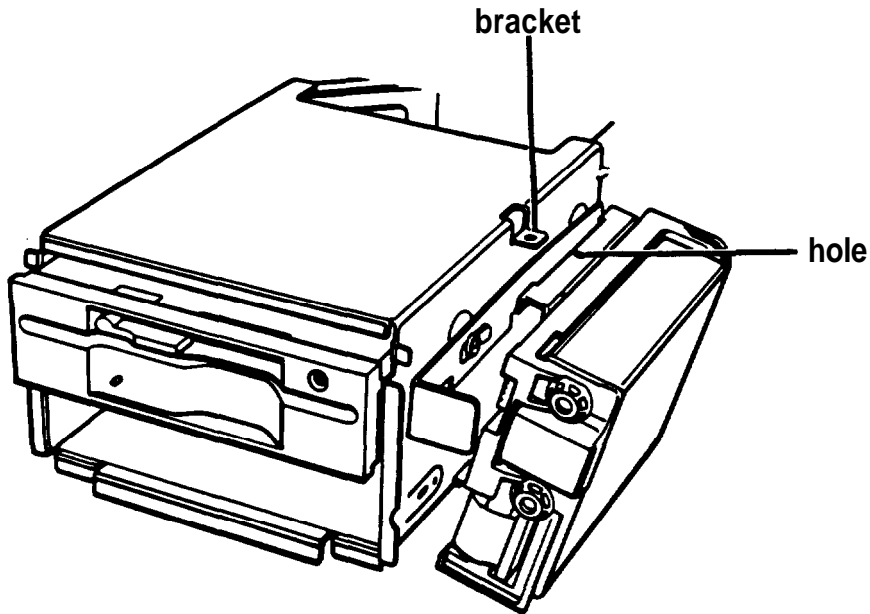

As shown above, fit the tabs on the mounting plate into the slots on the side of the subassembly. Then tilt the drive toward the subassembly and align the retaining screw hole on the mounting plate with the hole in the bracket.

8. Secure the drive to the bracket with the retaining screw.

If you are installing your first hard disk drive, follow the steps in the next section.

If you are reinstalling a hard disk drive, you are ready to replace the subassembly and the computer's cover. See Chapter 5 for instructions.

## ***Attaching the Cable to the Bottom of the Subassembly***

If you are installing your first hard disk drive, follow these steps to attach the drive cable to the bottom of the subassembly so it does not interfere with the components on your main system board:

1. Turn the subassembly over so the bottom side faces up and the hard disk drive is on your left.
2. Lay the hard disk drive cable (attached to your drive) on the subassembly.

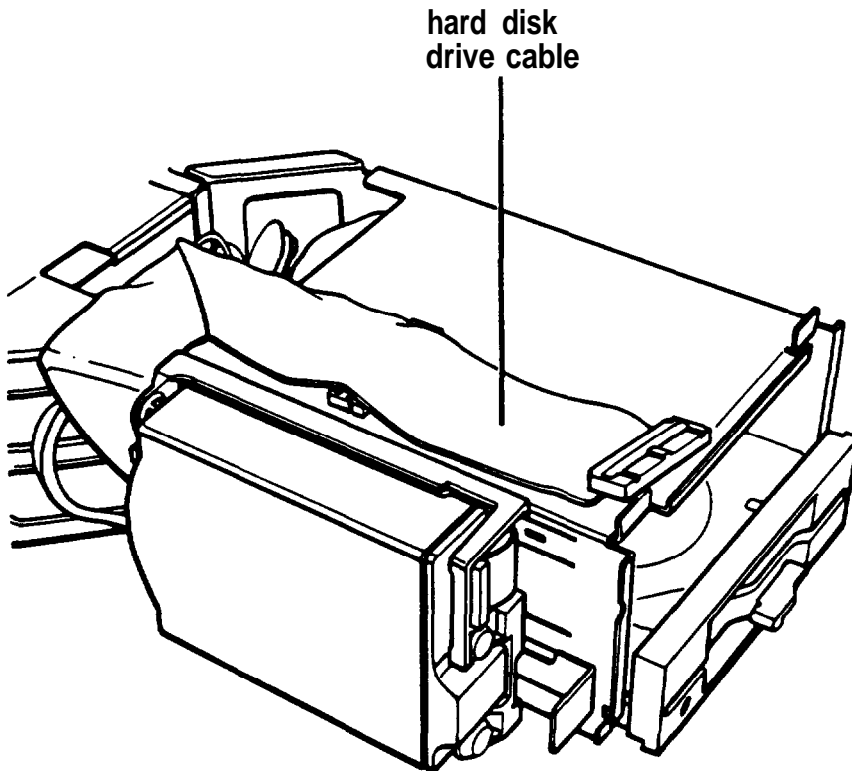

3. Locate the tie wrap and mount that came with your hard disk drive option kit. Slip the tie wrap through the hole in the mount.

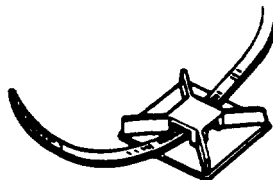

4. Wrap the tie wrap around the cable so that the mount is in between the cable and the subassembly, as shown below.

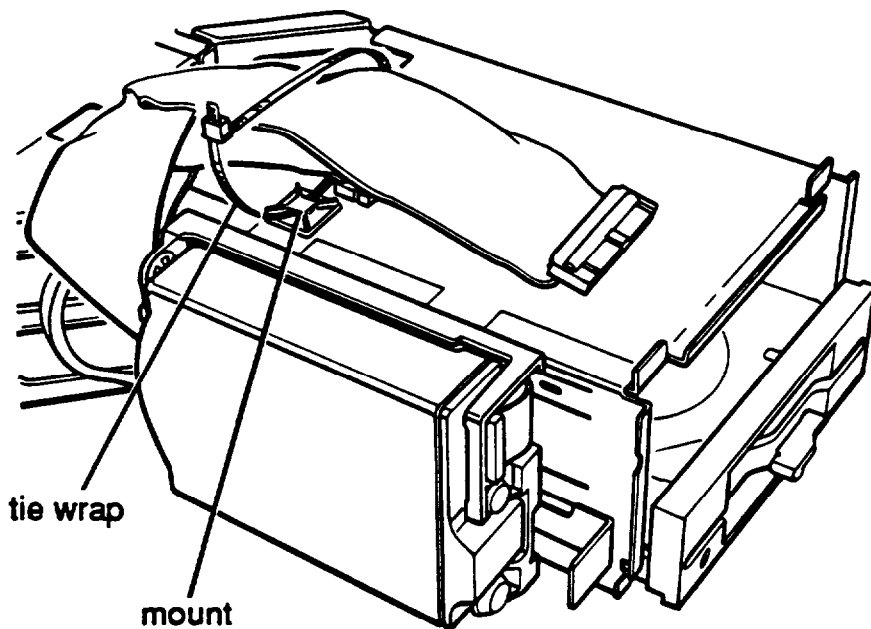

5. Peel the backing off the mount and attach the mount to the subassembly.
6. Turn the subassembly over again.
7. See “Replacing the Subassembly” in Chapter 5 for instructions on replacing the subassembly in your computer. Then see “Replacing the Cover,” also in Chapter 5, for instructions on replacing the computer’s cover.
8. See “Post-installation Setup” in Chapter 6 for instructions on configuring your computer for use with your new hard disk drive.

#### Note

After you change your computer’s drive configuration, the computer may take up to five minutes to complete power-on diagnostics the next time you turn it on.

---

## ***Removing a Hard Disk from the Vertical Position***

You need to remove the hard disk drive from the vertical position in the following cases:

- The drive needs servicing.
- You are replacing the drive.
- You are adding a second drive (either another hard disk drive or a diskette drive) in the lower horizontal position.

Follow these steps:

1. Remove the computer's cover and subassembly, if you have not already done so. See Chapter 5 for instructions.
2. Remove the retaining screw securing the hard disk drive mounting plate to the subassembly and set it aside.

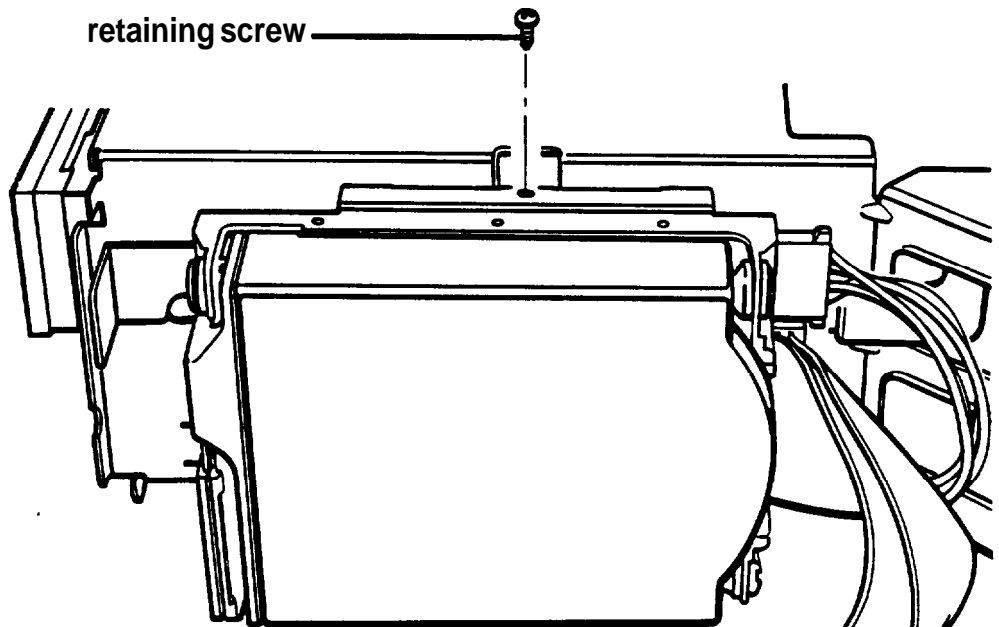

3. Tilt the hard disk drive slightly to the right and lift it up and away from the subassembly. Set the drive next to the subassembly so the component side faces up.

4. Disconnect the power supply connector and the ribbon cable connector from the sockets on the back of the hard disk drive, as shown below. Firmly pull the connectors straight out from the sockets so you do not bend the pins. Do not pull on the cables; pull on the plastic connector.

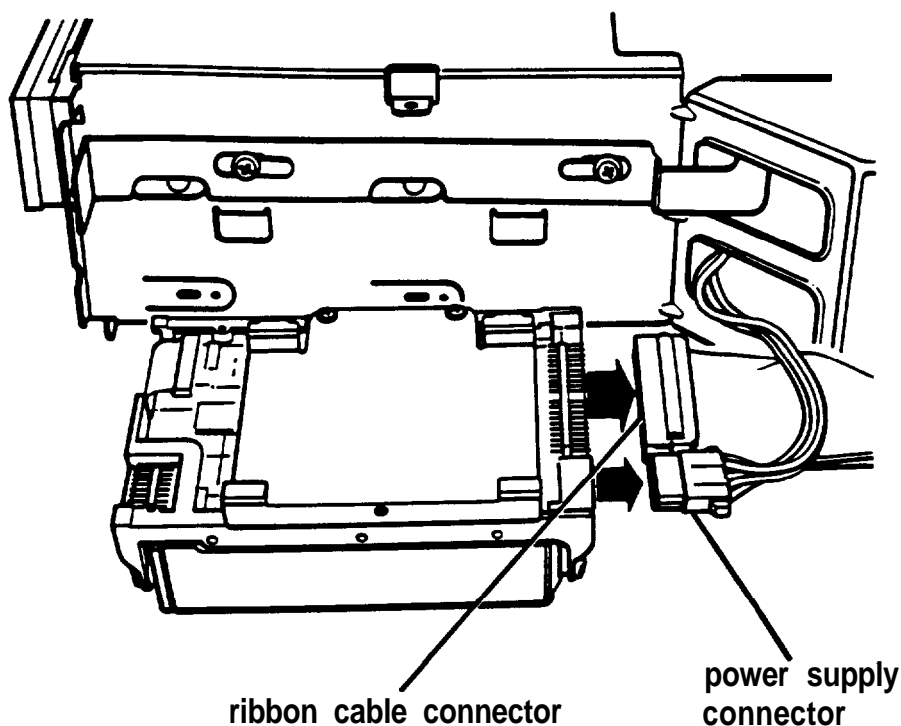

5. If you removed the drive because you are going to install or remove a drive in a horizontal drive bay, follow the instructions under “Installing or Removing a Disk Drive in the Horizontal Position” on page 7-23. Do not perform steps 6 through 11.

If you removed the drive to have it serviced, follow the instructions for “Installing the Drive” starting on page 7-12 after the drive is repaired.

If you are not going to reinstall the drive, go to step 6.

6. Remove the four screws securing the hard disk drive mounting plate to the hard disk drive. Then remove and store the mounting plate along with the screws.

7. Wrap the hard disk drive in its original packing materials and set it aside along with the hard disk drive ribbon cable.
8. Replace the subassembly in the computer, and then replace the computer's cover. See Chapter 5 for instructions.
9. See "Post-installation Setup" in Chapter 6 for instructions on configuring your computer for use without a hard disk drive.

### **Note**

After you change your computer's drive configuration, your system may take up to five minutes to complete power-on diagnostics the next time you turn it on.

---

## ***Installing or Removing a Disk Drive in the Horizontal Position***

This section describes how to install or remove a hard disk drive or a diskette drive in the lower horizontal drive bay. You can use these same instructions if you need to install a different diskette drive in the upper drive bay; however, the illustrations show the lower bay.

If you are installing a second hard disk or diskette drive, you must install it in the lower horizontal drive bay. Your first diskette drive is in the upper bay and your first hard disk is in the vertical mounting position.

If you have a hard disk drive installed in the vertical mounting position, you must remove it before you remove or install a drive in the horizontal drive bay. This enables you to access the mounting holes and screws for the horizontal bay. See "Removing a Hard Disk From the Vertical Position" starting on page 7-21.

## ***Installing a Disk Drive in the Horizontal Position***

Before you perform the following steps, be sure that you have set the jumpers on any hard disk drive(s) that you'll be using. (If necessary, see "Setting, the Hard Disk Drive Jumpers" on page 7-4 for instructions.)

If you are adding a **3 1/2-inch** diskette drive or hard disk drive, you need to make sure that **5 1/4-inch** metal mounting frames are attached to the drive so it fits properly in the drive bay. Epson **3 1/2-inch** drives come with mounting frames already installed. If your drive did not come with frames installed, follow the instructions in the manual that came with the drive to attach them.

The figures in this section show a diskette drive, but you can use the same instructions to install a hard disk drive.

Follow these steps to install a disk drive:

1. If you are installing a **5 1/4-inch** diskette drive, turn it so that the diskette release latch is above the diskette slot.

If you are installing a **3 1/2-inch** diskette drive, turn it so that the diskette release button is on the right and the drive light is on the left.

If you are installing a hard disk drive, turn it so that the side with the components is facing down.



2. There are two or three holes on each side of the disk drive. When you insert the drive, align the appropriate round holes in the drive with the two oval holes on each side of the drive bay, as shown below.

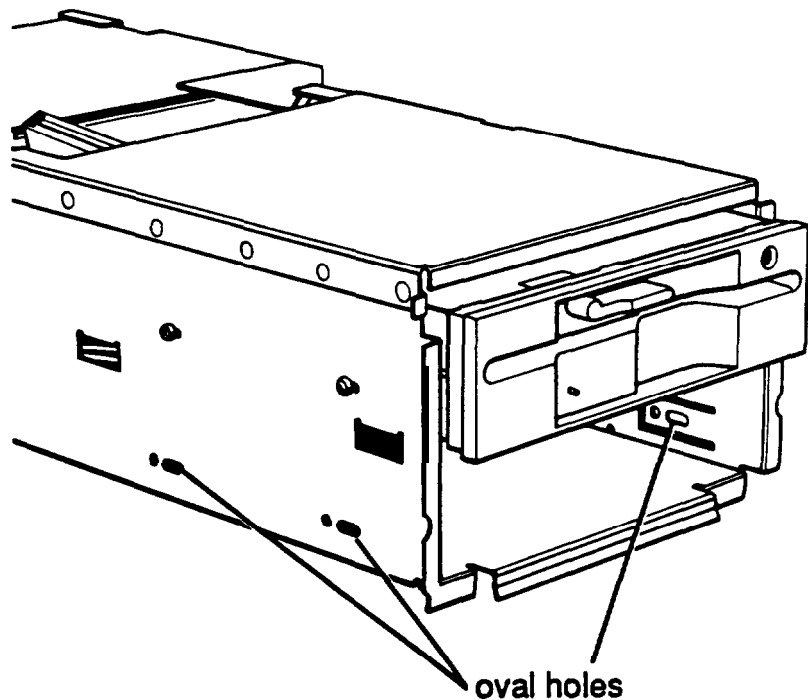

3. Insert the drive into the lower drive bay and slide it toward the back of the subassembly. Watch the oval holes on the side of the drive bay so you can see when the holes on the drive are positioned in the middle of them.

If you are installing a diskette drive, adjust its position so that the front of the drive lines up with the drive in the upper bay. (A hard disk drive fits all the way into the bay.)

4. After you align the drive, insert two screws into the oval holes on each side of the drive bay and tighten them with a screwdriver, as shown below.

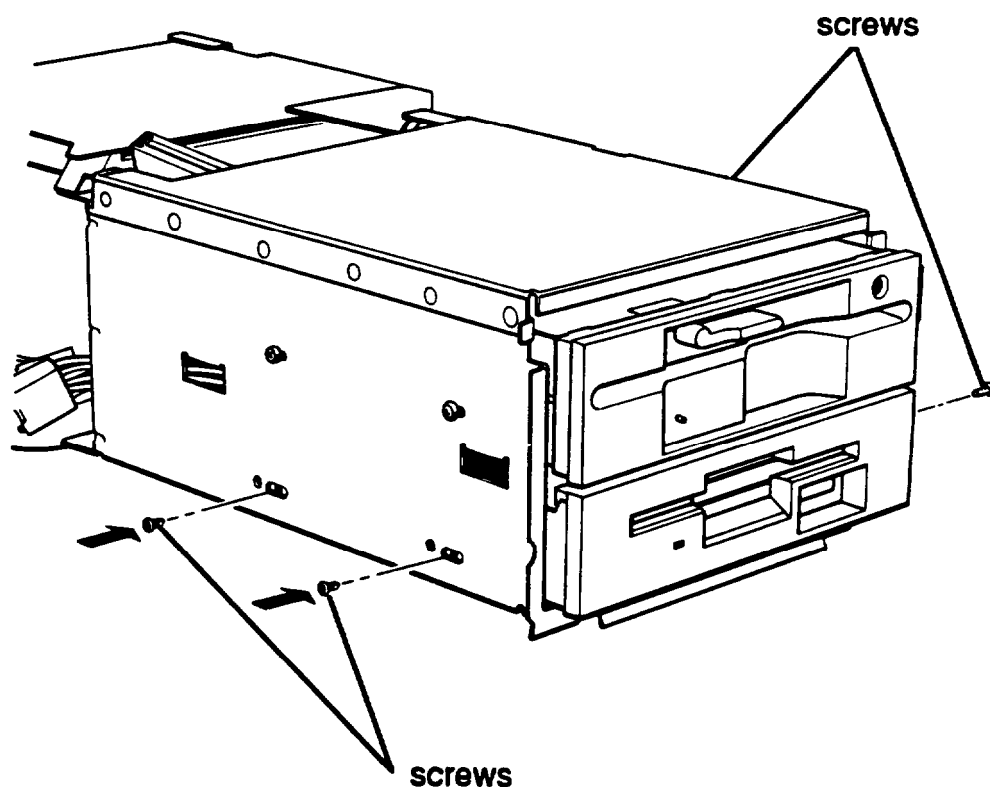

If you are installing a diskette drive, go to “Connecting a diskette drive.”

If you are installing a hard disk drive, go to “Connecting a hard disk drive.”

### **Connecting a diskette drive**

Follow these steps to connect a new diskette drive:

1. If you are installing a diskette drive in the lower drive bay, you may want to turn the subassembly upside down and place it on your work surface. The illustrations here show the cables and connectors as if the subassembly were in the upright position. However, when you install a drive in the lower bay, it is easier to access the cables if you turn the subassembly upside down.

Locate the diskette drive ribbon cable; one end is connected to the top diskette drive and the other end is free. Use the connector in the middle of the cable to connect the second diskette drive. As shown in the next illustration, there is a large slot in this connector with a small plastic divider near one end of the slot.

The interface that protrudes from the back of the drive has gold contacts on both sides. Near one end of the interface, there is a gap to accommodate the plastic divider on the connector.

2. Align the connector with the interface so that the plastic divider on the connector lines up with the gap in the interface.

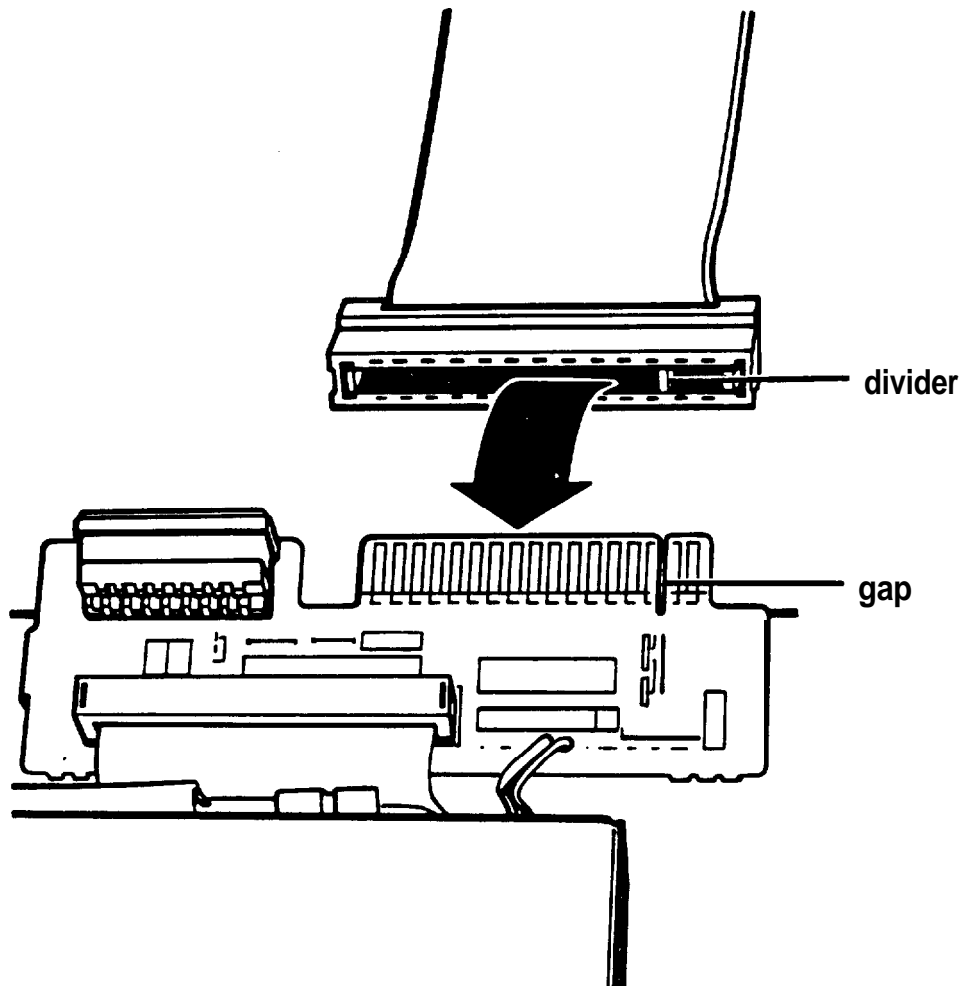

3. Make sure the cable connector fits properly onto the drive interface and then push it onto the interface.

### **Caution**

**If** you do not correctly align the connector, you could severely damage your diskette drive when you push it in.

At this point, you can remove the slot cover from the front panel.

1. Place the front panel face down and use a screwdriver to remove the two screws securing the slot cover to the panel. Lift out the slot cover, as shown below.

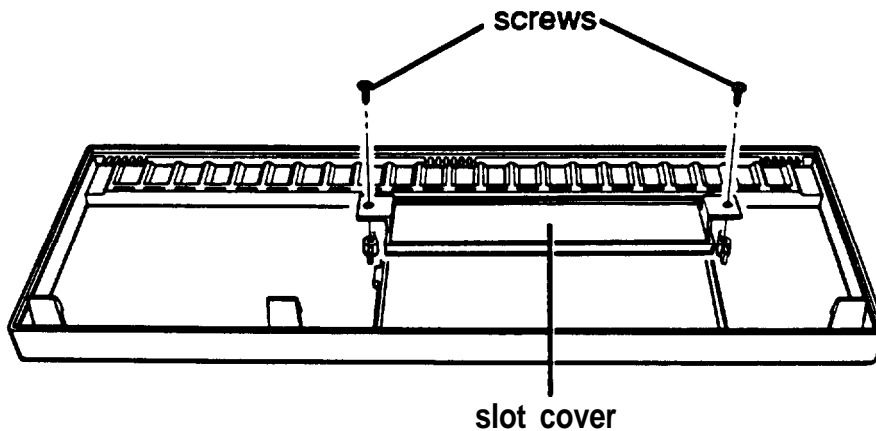

2. Set the front panel, slot cover, and screws aside.

Now go to “Connecting the power cables” for instructions on connecting the power cable.

## **Connecting a hard disk drive**

Follow these steps to connect a hard disk drive in the horizontal bay drive:

1. Before attaching cables to the hard disk drive, turn the subassembly upside down to make it easier to connect the cables.

2. Next, locate the hard disk drive ribbon cable that came with your computer. If you removed a drive from the vertical mounting position, the cable you disconnected from that drive should be strapped to the bottom of the subassembly by a tie wrap. Cut the tie wrap so you can access the connectors.

The hard disk drive ribbon cable has three connectors. The connector on one end goes to the system board. The other two connectors (closest together) go to the hard disk drives. Of these two connectors, you attach the middle one to the hard disk drive in the vertical position and you attach the end one to a hard disk drive in the lower horizontal bay.

As shown in the illustration below, there are two rows of holes in a hard disk drive connector. One of the holes is blocked with a plastic plug.

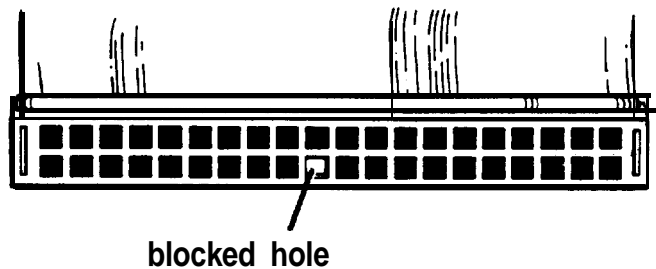

3. Notice the ribbon cable socket on the back of the drive you just installed; you see two rows of pins. In one of the rows, a pin is missing.

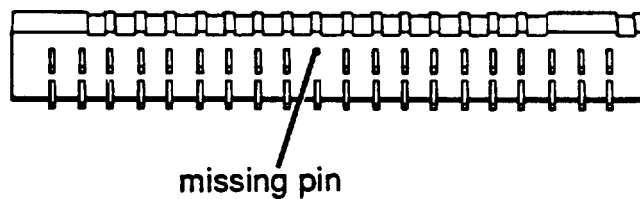

4. Align the ribbon cable connector with the socket on the hard disk drive. Make sure the row in the connector with the blocked hole lines up with the row in the socket with the missing pin, as shown below.

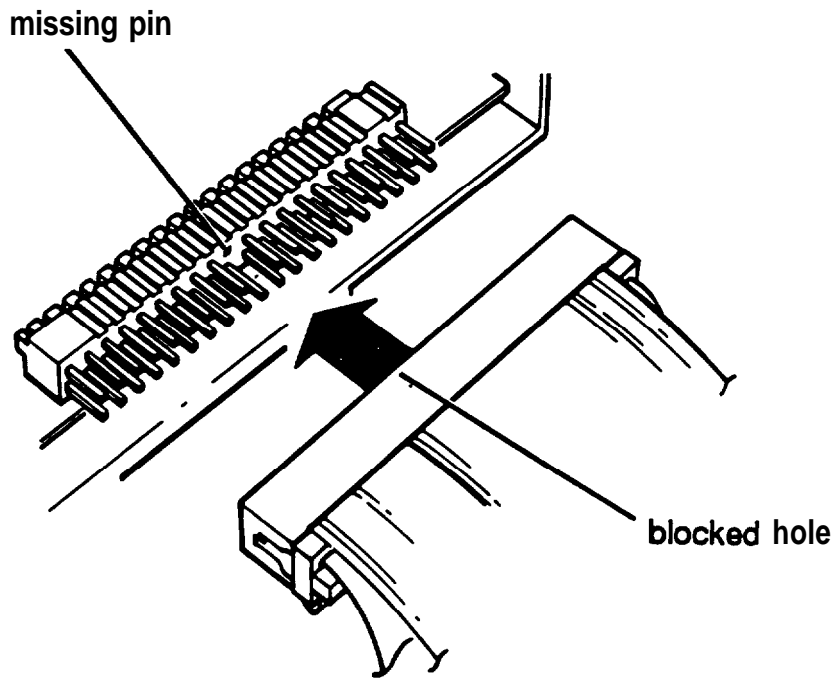

Make sure the holes fit over all the pins **and** then push the connector onto the pins.

### **Caution**

If you do not correctly align the holes with the pins, you could severely damage your hard disk drive when you push in the connector.

Now go to the next section for instructions on connecting the power cable.

## Connecting the power cables

Follow these steps to connect the power supply cable for either a diskette drive or a hard disk drive in the horizontal bay:

1. Looking at the subassembly, locate the power supply cables with clear plastic connectors labelled P1, P2, or P3 that lead from the power supply (behind the horizontal drive bays). (You connect the cables labelled P4 and P5 to the system board later.)

You must connect a power supply cable to each drive you install in your system. You can connect any of these three cables to the new disk drive. One of the cables, usually P1, is already attached to your first diskette drive.

As shown below, the end of the connector has two notched corners. The power supply socket on the back of the drive is next to the ribbon cable connector. The socket also has two notched corners.

power supply cable

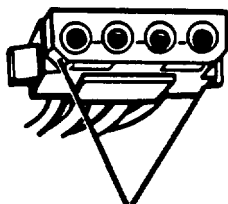

notched corners

power supply socket

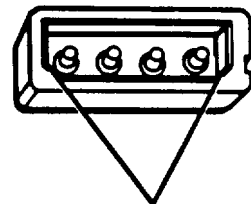

notched corners

2. Position the power supply cable connector so that the notched corners on the connector line up with the notched corners of the power supply socket on your drive.

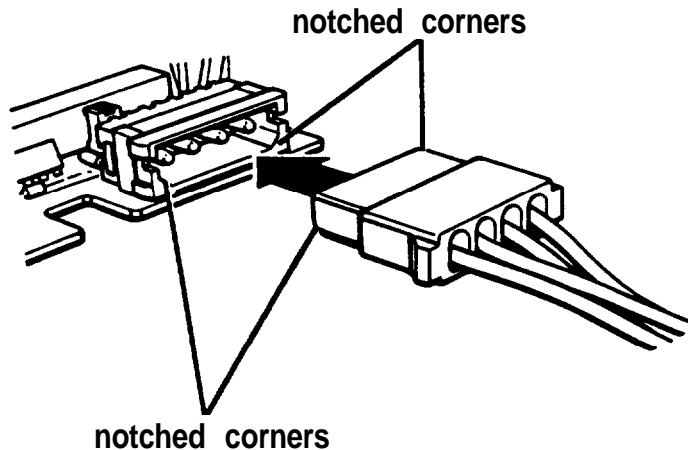

3. Make sure the holes fit over all the pins and then push the connector onto the pins.

#### Caution

If you do not correctly align the holes with the pins, you could severely damage your drive when you push in the connector.

4. Turn the subassembly right side up taking care to arrange the cables under the subassembly.

If you do not need to reinstall a vertically mounted hard disk drive, see 'Replacing the Subassembly' in Chapter 5.

To reinstall a vertically mounted hard disk drive, see "Installing the Drive" on page 7-12 for instructions.



## ***Removing a Disk Drive From the Horizontal Position***

The figures in this section show a diskette drive in the lower horizontal drive bay, but you can use the same instructions to remove a hard disk drive from the lower bay or to remove a diskette drive from the upper bay.

### Note

Before removing a disk drive from the horizontal position, you must remove the drive from the vertical position. See page 7-21.

Follow these steps to remove a drive from a horizontal drive bay:

1. Remove the disk drive ribbon cable from the back of the drive, as shown below.

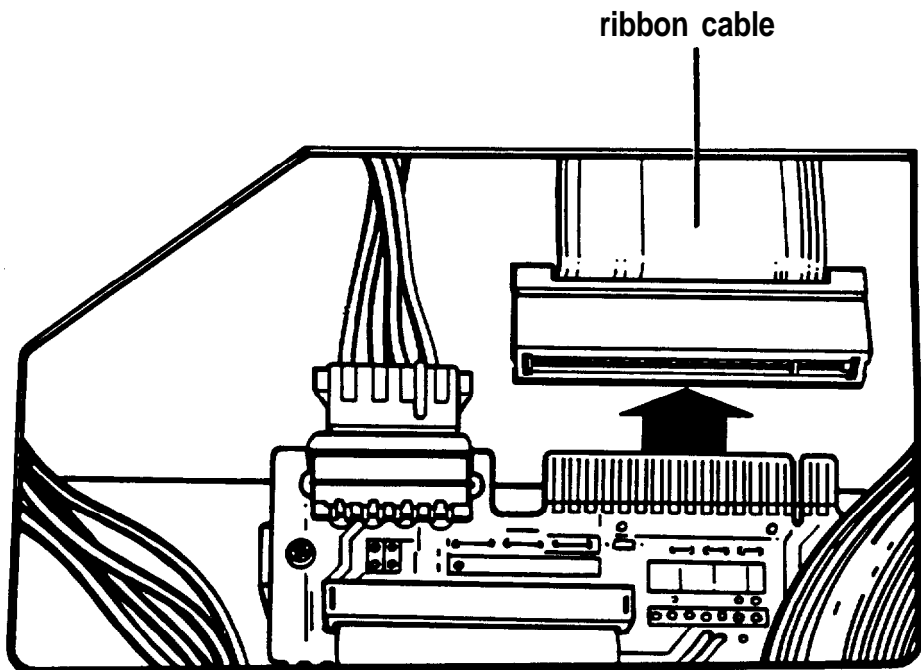

2. Remove the power supply connector from the back of the drive.

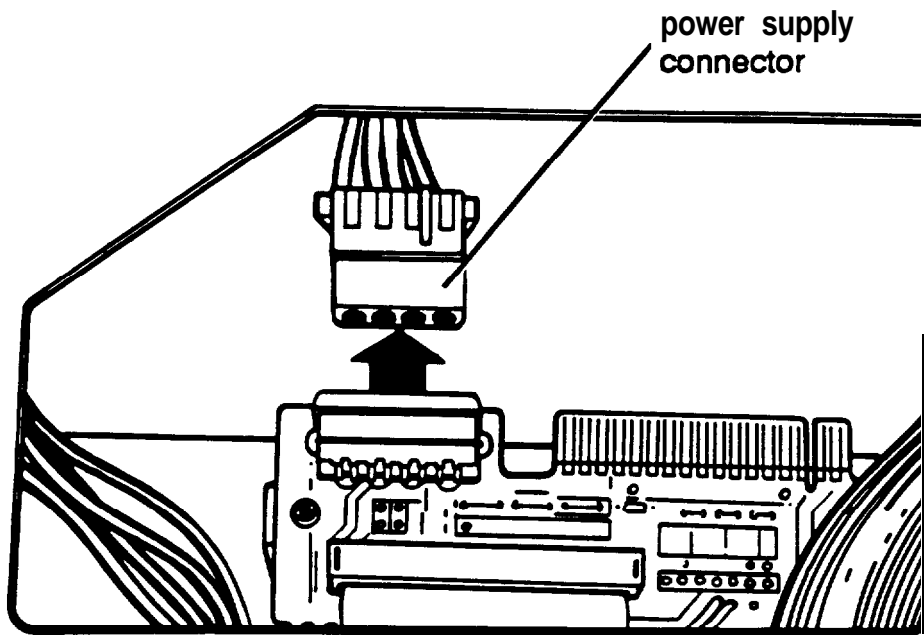

3. Using a screwdriver, remove the screws securing the drive to the drive bay. There are two screws on each side.

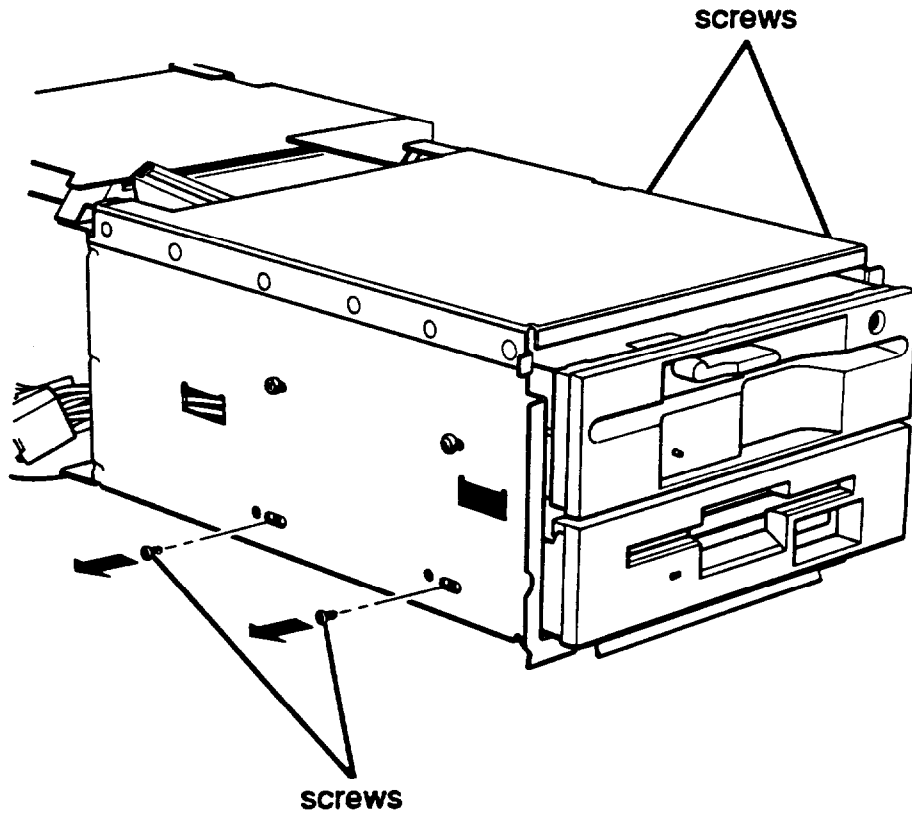

4. Grasp the disk drive from the front of the drive bay, pull it completely out, and set it aside.
5. If you have removed one hard disk drive and are leaving another one in your system, make sure you have set the jumpers on the remaining drive to indicate that you now have only one hard disk drive. (If necessary, see “Setting the Hard Disk Drive Jumpers” on page 7-4 for instructions.)

If you do not need to replace a hard disk drive in the vertical mounting position, see “Replacing the Subassembly” in Chapter 5.

If you need to reinstall a hard disk drive in the vertical mounting position, follow the steps under “Installing the Drive” on page 7-12.

If you have removed a diskette drive and are not replacing it with another diskette drive, or you are replacing it with a hard disk drive, replace the slot cover on the front panel.

## ***Troubleshooting***

You should not encounter any difficulties as you set up and use your computer, but if anything out of the ordinary happens, refer to this appendix. You can correct most problems by adjusting a cable connection, repeating a software procedure, or resetting the computer.

Besides trying the suggestions in this chapter, you can run diagnostics checks on the various components of your computer system. See Appendix C for instructions.

If the suggestions here or in Appendix C do not solve the problem, contact your authorized Epson dealer. Your dealer may be able to solve the problem; if not, he or she can refer you to an Authorized Epson Customer Care Center for service. If necessary, call the Epson Customer Information Center at (213) 782-2600 for the location of your nearest Authorized Epson Customer Care Center.

---

### ***Identifying Your System***

When you contact your dealer or Customer Care Center, be ready to provide the serial number of your computer, its configuration (including the type of disk drives, monitor, and option cards), and the names and version numbers of any software programs you are using. **YOU** can find the serial number on the computer's back panel.

If you are able to use MS-DOS, follow the steps below to obtain your MS-DOS version number and the version number of your computer's ROM BIOS.

If you have a hard disk, follow these steps:

1. At the MS-DOS command prompt, type ROMBIOS and press **Enter**. (You may need to log onto the directory where ROMBIOS.COM is stored.) Write down the version number displayed on your screen.
2. At the MS-DOS command prompt, type VER and press **Enter**. The screen displays the MS-DOS version number. Write down the number so you can give it to your dealer.

If you do not have a hard disk, follow these steps:

1. Insert the Reference diskette in drive A and turn on or reset your computer.
2. At the Operation Menu, select Exit to MS-DOS for more utilities and press **Enter**.
3. At the A> prompt, type ROMBIOS and press **Enter**. Write down the version number displayed on your screen.
4. Remove the Reference diskette and insert your Startup diskette in drive A. Type VER and press **Enter**. The screen displays the MS-DOS version number. Write down the number so you can give it to your dealer.

---

## ***Error Messages***

Your computer's built-in memory (ROM) contains a series of diagnostics programs, called power-on diagnostics, which your computer runs automatically every time you turn it on. These programs check internal devices such as ROM, RAM, the timer, the keyboard controller, and the hard disk drive. The RAM test program displays the total amount of memory currently installed in your system. If the computer finds an error, it displays a specific error number and error message on the screen.

If the error is not serious, you see this prompt :

(Resume = "F1" key)

Write down the error message and code number, and then press F1 to continue. Give the error message and code number to your dealer when reporting a problem.

If the error is serious, the computer cancels further checking and halts system initialization. The error message remains on the screen and the computer locks up. If this happens, contact your dealer as soon as possible. Report this information and both the error message and code number to your dealer.

The following table lists all the error codes and messages that may appear during power-on diagnostics checks. If you receive an error message, look it up in the table below. It directs you to the proper troubleshooting section in this appendix. If you do not see an error message, read the section that covers your problem.

#### Power-on diagnostics error codes and messages

| Error code             | Message                   | Action                   |
|------------------------|---------------------------|--------------------------|
| <b>System board</b>    |                           |                          |
| 101                    | System board error        | Contact dealer           |
| 102                    | System board error        |                          |
| 103                    | System board error        |                          |
| 105                    | <b>System</b> board error |                          |
| 106                    | <b>System</b> board error |                          |
| 107                    | System board error        |                          |
| 108                    | System board error        |                          |
| <b>Real-time clock</b> |                           |                          |
| 161                    | System options not set    | Contact dealer           |
| 162                    | System options not set    | Run Setup; see Chapter 2 |
| 163                    | Time and date not set     | Run Setup; see Chapter 2 |
| 164                    | Memory size error         | Run Setup; see Chapter 2 |

## Power-on diagnostics error codes and messages (continued)

| Error code                               | Message                       | Action  |
|--|-------------------------------|---|
| <b>Memory</b>                            |                               |   |
| <b>171</b>                               | BIOS shadow RAM error         | Contact dealer<br>Run Setup; see<br>Chapter 2                 |
| <b>173</b>                               | <b>Cache</b> options error    |   |
| <b>201</b>                               | Memory error                  |   |
| <b>202</b>                               | <b>Memory address</b> error   |   |
| <b>203</b>                               | Memory address error          |   |
| <b>Keyboard</b>                          |                               |   |
| <b>301</b>                               | Keyboard error                | See “Keyboard<br>Problems”                                    |
| <b>303</b>                               | Keyboard or system unit error |   |
| <b>304</b>                               | Keyboard or system unit error |   |
| <b>Monitor</b>                           |                               |   |
| <b>401</b>                               | CRT error                     | See “Monitor<br>Problems”                                     |
| <b>501</b>                               | CRT error                     |   |
| <b>Diskette drive(s) and controller</b>  |                               |   |
| <b>601</b>                               | Diskette error                | See “Diskette<br>Problems” or<br>“Diskette Drive<br>Problems” |
| <b>Parallel port (printer interface)</b> |                               |   |
| <b>901</b>                               | Parallel port error           | See “Printer<br>Problems”                                     |
| <b>Serial port (RS-232C port)</b>        |                               |   |
| <b>1101</b>                              | Serial port error             | See “Printer<br>Problems”                                     |
| <b>Hard disk drive(s) and controller</b> |                               |   |
| <b>1760</b>                              | Disk 0 parameter failure      | See “Hard Disk<br>Drive Problems”                             |
| <b>1761</b>                              | Disk 1 parameter failure      |   |
| <b>1770</b>                              | Disk 0 parameter error        |   |
| <b>1771</b>                              | Disk 1 parameter error        |   |
| <b>1780</b>                              | Disk 0 failure                |   |
| <b>1781</b>                              | Disk 1 failure                |   |
| <b>1782</b>                              | Disk controller failure       |   |
| <b>1790</b>                              | Disk 0 error                  |   |
| <b>1791</b>                              | Disk 1 error                  |   |

| Error code                 | Message                  | Action               |
|----------------------------|--------------------------|----------------------|
| <b>Auxiliary device(s)</b> |                          |                      |
| 8601                       | Auxiliary device failure | See "Mouse Problems" |
| 8602                       | Auxiliary device failure |                      |
| 8603                       | Auxiliary device failure |                      |

---

## ***The Computer Won't Start***

If your computer does not start when you turn on the power, check the following:

1. Is the power light on? If not, remove any diskettes and turn off the power. Check that the power cord is securely connected to both the AC inlet on the back panel and an electrical outlet. Replace the Reference or MS-DOS Startup diskette, if necessary, and turn on the computer again.

### **Caution**

If you turn off the computer for any reason, always wait at least five seconds before turning it back on. You can damage the computer if you turn it off and on rapidly.

2. If the power light still does not come on, check the electrical outlet for power. Turn off your computer and unplug the power cord from the wall outlet. Plug a lamp into the outlet, and turn it on to see if the outlet supplies power.
3. If the electrical outlet is working and all the connections are secure but your computer still won't start, call your dealer.

### **Note**

If the computer starts but you can't see anything on the screen, see "Monitor Problems," below.



---

## ***The Computer Does Not Respond***

If your computer locks up and does not respond when you type on the keyboard, follow these steps:

1. Some operations take longer than others to complete. For example, the computer takes longer to sort a database than to accept a single typed character. If your computer still does not respond after a reasonable length of time, proceed to the next step.
2. Your computer may take a long time to complete its power-on diagnostics if you have just made a change in your system's configuration. The first time you turn on your computer after making such a change, it can take up to five minutes to finish its self test, depending on what you changed. If the computer does not display the MS-DOS prompt after five minutes, press the **RESET** button and try again. If that doesn't work, insert the Reference diskette in drive A and press the **RESET** button. If the computer still does not boot, contact your Epson dealer.
3. Did you enter the correct password? See "Password Problems," below.
4. Could your software be causing the problem? If you are running an application program, see "Software Problems," later in this appendix.
5. The problem could be caused by your keyboard. See "Keyboard Problems," later in this appendix. If your keyboard is operating properly, proceed to the next step.
6. If you want to stop whatever the computer is doing and return to the MS-DOS command prompt, hold down the **Ctrl** key and press **Break** (or press C). See Chapter 3 for more information on stopping a command or program.

7. If your computer still does not respond, you can reset it using the **Ctrl Alt Del** command. If that command doesn't work, you can reset the computer with the **RESET** button. See "Resetting Your Computer" in Chapter 3 for more information.
8. If resetting the computer does not work, turn off the computer and wait at least five seconds. If you do not have a hard disk drive, insert the MS-DOS Startup diskette in drive A. Then turn on the computer. It should load MS-DOS; if not, contact your Epson dealer.
9. If you installed an EGA or VGA display adapter card, or another type of card that you want to be the primary display adapter, you must set jumper J2 to disable the built-in VGA adapter. Otherwise, you will not see any display on the screen. See "Changing the Jumper Settings" in Chapter 6 for instructions.

If you are using one or more display adapter cards, you may also need to change the setting of jumper J1. This jumper tells the computer whether you are using a color or monochrome monitor. (J1 is set for color at the factory.) If the jumper is set incorrectly, you see one of these messages:

- ❑ 401 CRT error
- ❑ 501 CRT error.

If you are using two different types of video cards, set jumper J1 to the primary monitor type. You may also need to change the setting later if you change the type of monitor you are using. See "Changing the Jumper Settings" in Chapter 6 for instructions.

---

## ***Password Problems***

If you set a power-on password using the Setup program, you must enter this password before you can use the system. When you turn on the computer, the screen displays a key prompt (  ). If you do not enter the correct password, you see an X on the screen. The computer gives you a second and third chance to enter it correctly. If after three tries you have not entered the correct password, the computer locks up and does not respond to your keyboard entries.

### **Note**

If you enabled network server mode when you set a password, you do not see the key prompt. For more information, see "Using Your Computer as a Network Server" in Chapter 4.

If you have any trouble using your password, try the following:

1. If you think you know the correct password, press **RESET** and try again. See Chapter 3 for instructions.
2. If you know the current power-on password but you want to change or delete it, see Chapter 3 for instructions. (You cannot change or delete a power-on password and remain in network server mode.)
3. If you entered a password and then saw the following message, you need to change a jumper setting inside the computer:

TURN OFF POWER AND CORRECT JUMPER  
SETTING TO ENABLE PASSWORD CHECKING

Remove any diskettes, turn off the computer, and follow the instructions under "Changing the Jumper Settings" in Chapter 6 to enable the password function.

4. If you do not know the current power-on password and you do not want to set a new one, see “Removing a Password” below.
5. If you do not know the current power-on password and you want to set a new one, see “Setting a New Password” below.

### ***Removing a Password***

If you have forgotten your password and you do not want to set a new one, there are two ways to remove the current password:

- Disable the existing password
- Disable the password function.

To do either of these procedures, you must reset a jumper on the main system board.

#### **Note**

If you are using network server mode and you remove the password, the computer automatically turns off network server mode.

If you want to be able to set a new password later without having to change the jumper setting again, disable the existing password (not the password function). See “Disabling an existing password,” below, for instructions.

If you disable the password function, you cannot set a new password unless you perform the steps to disable the existing password at that time. If you do not want to use a password anymore, follow the instructions under “Disabling the password function” below.

## Disabling an existing password

If you do not know your power-on password and do not want to set a new one, follow these steps to disable the existing password:

1. Turn off the computer and follow the instructions under “Changing the Jumper Settings” in Chapter 6 to disable the password function (jumper J3).
2. Insert the Reference diskette in drive A and turn on the computer. You do not see the key prompt.
3. When the Operation Menu appears, highlight Set up and press **Enter**. Then see “Setting the Power-on Password” in Chapter 2 and follow the instructions as if you are going to enter a new password. However, when you see the prompt to enter a password, press **Enter** immediately. This clears out the existing password.

Be sure to save the password setting and highlight

**\*\* EXIT AND SAVE \*\*** when you leave Setup.

4. Remove the Reference diskette, turn off the computer, and follow the instructions under “Changing the Jumper Settings” in Chapter 6 to enable the password function (jumper 13).
5. If you do not have a hard disk, insert the MS-DOS Startup diskette in drive A. Turn on the computer again. You do not see the key prompt and the computer loads MS-DOS.

Later, if you want to create a power-on password, run Setup and enter a password. The jumper is already in the correct position.

## Disabling the password function

If you do not want to use a power-on password anymore, you can disable the password function. However, if you want to use the password function later, your old password is still stored as the current password. If you want to be able to easily set a password later, follow the instructions in “Disabling an Existing Password,” above.

To disable the password function, follow the instructions under “Changing the Jumper Settings” in Chapter 6 to change the setting of jumper J3.

## Setting a New Password

If you have forgotten your current power-on password and want to set a new one, follow these steps:

1. Turn off the computer and follow the instructions under “Changing the Jumper Settings” in Chapter 6 to disable the password function (jumper J3).
2. Insert the Reference diskette in drive A and turn on the computer. You do not see the key prompt.
3. When the Operation Menu appears, highlight `Set up` and press **Enter**. Then follow the instructions under “Setting the Power-on Password” in Chapter 2 to enter a new password. (If you want to enable network server mode, highlight `Network Server Mode` and press **Enter** to turn on the function.)

Be sure to save your password setting and highlight  
`** EXIT AND SAVE **` when you leave Setup.

4. After you exit Setup, you see this message:

```
TURN OFF POWER AND CORRECT JUMPER  
SETTING TO ENABLE PASSWORD CHECKING
```

5. Remove the Reference diskette, turn off the computer, and follow the instructions under “Changing the Jumper Settings” in Chapter 6 to enable the password function (jumper J3).
6. If you do not have a hard disk, insert the MS-DOS Startup diskette in drive A. Turn on the computer. You see the key prompt (  ). If you enabled network server mode, you do not see the key prompt. Enter your new password to access the system. (See "Using the Power-on Password" in Chapter 3 or “Using a Password in Network Server Mode” in Chapter 4.)

#### Note

Be sure to remember your new password or write it down and keep it in a safe place. If you forget the password you enter now, you may have to repeat the procedure above the next time you turn on your computer.

---

## ***Keyboard Problems***

If you are having trouble with the keyboard, check the following:

1. If the screen displays one of the following keyboard errors when you turn on or reset the computer, make sure the keyboard is securely connected to the keyboard socket on the back of the computer:
  - 301 Keyboard error
  - 303 Keyboard or system unit error
  - 304 Keyboard or system unit error.

## Note

Be sure the keyboard plug is inserted into the keyboard socket and not the mouse socket.

See “Connecting the Keyboard” in Chapter 1 for instructions.

2. If the cursor keys do not work properly, the num lock function may be on. When num lock is on, the numeric/arrow keys on the numeric keypad work only as numbers. Check to see if the **Num Lock** indicator in the upper right corner of the keyboard is lit; if it is, press the **Num Lock** key to turn off the function.

If you want to change the initial setting of the num lock function when you turn on the computer, see “Using the Keyboard and Speaker Options” in Chapter 2.

3. If nothing happens when you type on the keyboard, see “The Computer Does Not Respond,” above to see if something other than the keyboard is causing the problem.

---

## ***Monitor Problems***

For monitor problems, check the following:

1. If there is no display on the screen, check that the monitor’s power switch is on and that the power light on the monitor is lit. If the power light is on but you still do not see anything on the screen, check the monitor’s brightness and contrast controls.
2. If the power switch is on but the power light is not, turn off the monitor’s power, wait five seconds, and turn the power back on. Wait to see if the screen displays any text.



3. If the monitor's power light still does not come on, check the electrical outlet for power. Turn off your monitor and unplug it from the wall outlet. Plug a lamp into the wall outlet and turn it on to see if the outlet supplies power.
4. If you still do not see anything on the screen, make sure your monitor is connected to the computer properly. See "Connecting a Monitor" in Chapter 1 for more details. Also check the monitor manual for instructions on how to connect it to the computer.
5. Make sure your monitor and display adapter match, and, if you installed a display adapter card, be sure any switches or jumpers on the card are set properly. See "Connecting a Monitor" in Chapter 1 and the documentation that came with your monitor and display adapter card for instructions.
6. Be sure you have chosen the correct display adapter type in the Setup program. See "Setting the Display Adapter Type" in Chapter 2.
7. If you are running an application program, see if you need to set up the program for the type of monitor and display adapter you have. Also make sure you are using the appropriate monitor and display adapter for your software.

#### Note

If your application program requires a monitor that supports graphics but you have a monochrome monitor, the results will be unpredictable.

8. If you installed an EGA or VGA display adapter card, or another type of card that you want to be the primary display adapter, you must set jumper J2 to disable the built-in VGA adapter. Otherwise, you will not see any display on the screen. See "Changing the Jumper Settings" in Chapter 6 for instructions.

If you are using one or more display adapter cards, you may need to change the setting of jumper J1. This jumper tells the computer whether you are using a color or monochrome monitor. (J1 is set for color at the factory.)

If the jumper is set incorrectly, you will see one of these messages:

- 401 CRT error
- 501 CRT error.

If you are using two different types of video cards, set jumper J1 to the primary monitor type. You may also need to change the setting later if you change the type of monitor you are using. See “Changing the Jumper Settings” in Chapter 6 for instructions.

9. If you are still having difficulty with your monitor, run either the Monochrome Display Adapter and CRT check or the Color Graphics Adapter and CRT check, described in Appendix C. If the diagnostics program indicates an error, contact the place where you bought the monitor.

---

## ***Diskette Problems***

You may see the following message if you are having trouble with a diskette or your diskette drive:

601 Diskette error

If you see this message or have trouble accessing data on a diskette, try the following steps:

1. Did you turn down the diskette drive latch on a 5 1/4-inch drive to secure the diskette in the drive? See Chapter 3 for more information.

2. You may have inserted the diskette upside-down or it may not be inserted all the way. Remove the diskette from the drive and reinsert it with the label facing up. Be sure to turn down the diskette drive latch. (See Chapter 3 for detailed instructions on inserting and removing diskettes.)
3. If reinserting the diskette does not solve the problem and you have access to another diskette drive of the same type, place the diskette in the other drive and repeat the operation. If this works, the trouble may be in your diskette drive. See “Diskette Drive Problems,” below.
4. Check to see if you have inserted the right type of diskette. Follow these guidelines:
  - ❑ In a 1.2MB drive, use **5 1/4-inch**, double-sided, high-density, 96 TPI diskettes. You can also use a 360KB diskette, but if you write to it in this drive, you may have trouble using it in a 360KB drive later.
  - ❑ In a 1.44MB drive, use **3 1/2-inch**, double-sided, high-density, 135 TPI diskettes. This type of drive can also read and write to 720KB diskettes.
  - ❑ In a 360KB drive, use **5 1/4-inch**, double-sided, double-density, 48 TPI diskettes. You cannot use 1.2MB diskettes in this drive.
  - ❑ In a 720KB drive, use **3 1/2-inch**, double-sided, double-density, 135 TPI diskettes. You cannot use 1.44MB diskettes in this drive.

See “Types of Diskette Drives” in Chapter 3 for more information.

5. If your diskette is the right type for your drive, see if it is write-protected. On a **5 1/4-inch** diskette, there may be a write-protect tab over the notch on its side or there may be no notch. On a **3 1/2-inch** diskette, the write-protect switch may be set to the write-protect position or there may be no switch. You cannot alter data on a write-protected diskette. (Some application programs do not function properly if the diskette is write-protected. Check the program manual.) See Chapter 3 for more information.
6. Is the diskette formatted? A new diskette must be formatted before you can store data on it. See your MS-DOS Reference Manual for instructions on formatting diskettes.
7. You may have entered an incorrect diskette drive type when you ran the Setup program. Run the Setup program again to check the setting. See Chapter 2 for instructions.
8. Did you receive one of the following MS-DOS error messages?
  - Disk Drive Error: Abort, Ignore, Retry?
  - Disk error reading drive d:
  - Disk error writing drive d:

If you see one of these messages, make sure the diskette is properly inserted in the drive. On a **5 1/4-inch** diskette drive, make sure the drive latch is closed. Try the operation again. If the problem persists, try removing the diskette and reinserting it. This may solve the problem if the diskette was not seated properly in the drive.

If the error message still occurs, you may have a defective diskette. Use the MS-DOS COPY command to copy the files from the bad diskette to a new diskette. (See your MS-DOS Reference Manual for instructions.)

9. If you see no error messages but there is something wrong with the data in a file, MS-DOS or an application program may have updated the storage information on the diskette incorrectly. This is probably the case if you have one of these problems:

- Part of a file is missing
- A file includes parts of other files
- An expected output file is missing.

To make the necessary repairs, use the **MS-DOS** program CHKDSK. See your MS-DOS Reference Manual for instructions.

---

## ***Diskette Drive Problems***

You may see the following message if you are having trouble with a diskette or your diskette drive:

601 Diskette error

If you see this message or have difficulty with a diskette drive, follow these steps:

1. Try running the Diskette Drives and Controller Check described in Appendix C. If the diagnostics program indicates an error, consult your Epson dealer.
2. If the diskette drive is making loud noises, do not attempt any further examination of it. Contact your Epson dealer.

### Note

Diskette drives may make different sounds with different diskettes.

3. If your diskette drive read/write heads are dirty, you may occasionally see this MS-DOS error message:

```
Error Reading Drive d:  
Abort, Retry, or Fail?
```

To clean the read/write heads, use a diskette drive head cleaning kit, available from most computer stores. However, do not use a cleaning kit too often because excessive cleaning can damage your drive heads.

---

## ***Hard Disk Problems***

If you are having problems with the hard disk in your computer, you may see one of the following error messages:

- 1760 Disk 0 parameter failure
- 1761 Disk 1 parameter failure
- 1770 Disk 0 parameter error
- 1771 Disk 1 parameter error
- 1780 Disk 0 failure
- 1781 Disk 1 failure
- 1782 Disk controller failure
- 1790 Disk 0 error
- 1791 Disk 1 error.

The problem could be the result of improper installation, incomplete disk preparation, or corrupted data. The suggestions in this section are divided into three categories:

- ❑ Installing the drive
- ❑ Preparing the drive for use
- ❑ Accessing data on the drive.

Consult the section that seems most likely to cover the problem you are having. For example, if you have been able to use data on your disk in the past but suddenly cannot, see “Accessing Data on the Drive.”

### **Caution**

If your disk has data on it, be very careful before you perform any procedure that may erase data (such as formatting the disk). Consult your dealer if you have any questions. Always be sure to back up your data before reformatting or repartitioning the disk drive. See the descriptions of COPY, XCOPY, and BACKUP in your MS-DOS Reference Manual.

## ***Installing the Drive***

If you are having problems with a newly-installed drive, check the following:

1. If your dealer installed the drive, consult that person about the problem.
2. If you have installed the hard disk in your computer yourself, did you carefully follow all the instructions in Chapter 7 of this manual? Review the instructions and check all the cable connections to make sure you have installed it correctly. Also check the jumper settings on your drive to make sure they are set correctly.

3. If you installed a non-Epson hard disk drive, was it physically formatted by the manufacturer? A blank, new hard disk must be formatted (or “initialized”) before you can partition it and install an operating system on it. This type of format is usually done by the manufacturer; if yours was not, you must do it yourself. If the drive came with its own format utility, use that program; if not, follow the instructions in Appendix B under “Hard Disk Format.”

Note that this physical type of format is different from the software-based type of formatting commands (such as the MS-DOS SELECT or FORMAT commands). See “Preparing the Drive,” below, for more information.

### Caution

Do not perform the low-level format if your disk contains data, unless your dealer advises you to do so.

4. If your computer came with a hard disk drive that you are no longer using, make sure the hard disk drive power cable and the cable that connected the drive to the main system board are disconnected.
5. If you installed a hard disk drive with its controller on a card, did you disable the built-in hard disk drive controller and select the correct drive type through Setup? See Chapter 2 for instructions.

## ***Preparing the Drive***

Before you can store data on a new hard disk (which has already been physically formatted), you must do the following to prepare it for use:

1. Run the Setup program to define your hard disk as part of the computer’s configuration. (See Chapter 2 for instructions.)



2. Partition the drive, format it for MS-DOS, and install MS-DOS. Step-by-step instructions for performing these procedures are provided in your MS-DOS Installation Guide. If you are using another operating system, follow the instructions that came with it.

If you do not prepare the drive correctly, you will not be able to store data on the disk. For example, if you have partitioned the drive and formatted it for MS-DOS (or another operating system) but you do not copy the operating system to the drive, you will not be able to load the operating system from the hard disk when you turn on the computer.

If you are sure the hard disk has been installed properly and you have prepared it for use as described above but you cannot access the drive, review the instructions in your MS-DOS Installation Guide. Make sure you performed each step in the installation process correctly for your configuration.

If you cannot identify the problem, consult your dealer.

### ***Accessing Data on the Drive***

If you have been using your hard disk drive successfully for some time and notice a reduction in performance, the data on the disk may have become fragmented. You may want to back up all your data and then use a disk compaction utility to reorganize the files on your disk. Contact your dealer for information.

If you still have trouble with your hard disk, you can back up your data and physically format the disk. Then you'll need to reinstall MS-DOS and copy your files back onto the disk. See "Hard Disk Format" in Appendix B and your MS-DOS Reference Manual for instructions.

If you cannot access data on your hard disk or you are receiving read/write errors, the disk may have a physical problem. Contact your dealer.

---

## **Software Problems**

If you are having trouble with an application program, try the following solutions:

1. If the application program does not start, check that the program is installed correctly and that you are following the correct procedure for starting the program. If you have a hard disk and the program is stored in a directory on that drive, make sure you are logged onto or specifying the correct directory. If you don't have a hard disk, make sure you have inserted the application program diskette in the top drive (usually drive A).
2. Your computer can run at either high speed (20 MHz) or low speed (simulated 8 MHz). While almost all programs work properly at the faster speed, some must run at the slower speed. Check your software manual to see if this is the case, and change the processor speed if necessary. See "Changing the Processor Speed" in Chapter 4 for instructions and for information on accommodating copy-protected programs.
3. If you have entered an MS-DOS command that you want to stop, there are special key combinations you can type to tell MS-DOS to stop what it is doing. These methods may also work in your application programs.

To interrupt an MS-DOS command while it is executing, try one of the following commands:

- Hold down the Ctrl key and press C
  - Hold down the Ctrl key and press **Break**.
4. An application program can occasionally lock the computer, making it unresponsive to the keyboard. If your computer does not respond when you type on the keyboard, you can reset it. Follow the instructions in Chapter 3.

---

## **Printer Problems**

Below are some general steps to follow if you are having difficulty with your printer. If the problem persists and you need more detailed information, check your printer manual. You may see one of the following error messages:

- ❑ 901 Parallel port error
- ❑ 1101 Serial port error.

These error messages appear if you are having trouble with the port to which your printer is connected. If it is connected to the parallel port, you may see error number 901; if your printer uses the serial port, you may see error number 1101.

1. If your printer does not work correctly immediately after you install it, check that the printer has power and is properly connected to the computer. (Also, make sure your printer has paper in it.) See Chapter 1 or your printer manual for instructions.
2. Check the printer manual for the printer's correct DIP switch or control panel settings. These settings help a printer communicate properly with the computer.
3. If you are using more than one parallel port or more than one serial port, the computer must know which port is the primary port and which is the secondary port. See Chapter 2 for instructions on how to set the parallel and serial ports using the Setup program.
4. If your printer is properly set up but is still not functioning, test it from the MS-DOS level. When the screen displays the MS-DOS command prompt (such as C> or A>), hold down **Shift** and press **Print Screen**. This should print the contents of the screen on your printer.

If it does not, you may need to change the internal setting of the computer's parallel port for a parallel printer (or serial port for a serial printer). To do this, use the MS-DOS MODE command or the MENU utility. See your printer manual and the MS-DOS Reference Manual for more details.

5. Many application programs (such as word processors) must be set up properly before they can use a printer. Check your program manual to see what customizing may be required.
6. Try running the Parallel Port (Printer Interface) check if you have a parallel printer, or the Serial Port (RS-232C) check if you have a serial printer. Appendix C describes these diagnostics checks. If the diagnostics test indicates an error, contact the place where you bought the printer.

---

### ***Option Card Problems***

If you install an option card and it is not functioning properly, check the following:

1. Is the option card installed correctly? The most common problem with option cards is a loose connection. Make sure the option card is well-seated in its slot. Check the installation procedure described in Chapter 6 and also see the instructions that come with the option card.
2. Did you set the necessary DIP switches or jumpers on the option card? See your option card manual for instructions.
3. Did you set the necessary jumpers on the main system board? See Chapter 6 for more information.
4. Did you run the Setup program to redefine your computer's configuration after installing the card? See Chapter 2.

5. Did you install a hard disk drive that has its controller on an option card? If so, and if your computer came with a hard disk drive that you are no longer using, be sure the cable leading from that drive to the main system board and the hard disk drive power cable are disconnected.
6. If you used the option card to add an external device to your computer, did you use the proper cable to connect the device to the option card connector on the back panel?
7. Did you perform the correct setup procedures for the software you are using with the option card? If necessary, see your software manual for instructions on running the software setup procedure.

---

## ***Mouse Problems***

If you are having a problem with your mouse, you may see one of the following error messages:

- 8601 Auxiliary device failure
- 8602 Auxiliary device failure
- 8603 Auxiliary device failure.

If you see one of these messages, make sure that the mouse cable is securely connected to the mouse port and not the keyboard port. See Chapter 1 for more information.

---

## ***Memory Module Problems***

If you added extra memory to your system by installing SIMMs and that memory is not operating properly, check the following:

1. If the memory count displayed by the power-on diagnostics program is incorrect, you or your dealer may not have installed the SIMMs correctly. They may be installed in the wrong sockets, they may be the wrong type of SIMM, or they may not be inserted all the way into their sockets. (Keep in mind that the memory count does not include 128KB of the standard 2MB of memory.)

If your dealer installed SIMMs for you, contact your dealer; do not attempt to correct the problem yourself. If you installed the SIMMs, see “Adding Memory Modules” in Chapter 6 and make sure you have followed all the necessary instructions.

2. Be sure to run the Setup program after you install or remove memory modules to automatically update your memory configuration. See Chapter 2 for instructions.
3. If you are still having trouble with your SIMMs, write down any error messages that appear and contact your dealer.

---

## ***Math Coprocessor Problems***

If your math coprocessor does not seem to be operating properly, check the following:

1. Run the Setup program on your Reference diskette and check to make sure that the math coprocessor is listed as installed on the Exit display. If it is listed as not installed, you or your dealer may have installed the math coprocessor incorrectly. See Chapters 2 and 6 for more information.

**Caution**

Do not attempt to remove the math coprocessor yourself. Contact your dealer for information about a special extraction tool that is needed to remove it.

2. If your math coprocessor is listed as installed in the Setup program but still does not seem to be working, check the manual that came with the math coprocessor for any additional procedures you may need to perform or any troubleshooting information.
3. If you are still having trouble with your math coprocessor, test it by running the System diagnostics program on your Reference diskette. See Appendix C for instructions. If your math coprocessor came with its own diagnostic program, check the documentation that came with it and run those tests also.

## ***Physically Formatting a Hard Disk***

This appendix describes how to physically format a hard disk. Sometimes called a low-level format, this procedure should not be confused with the logical format performed by the MS-DOS FORMAT command. The physical formatting of a hard disk is a separate step that is usually done at the factory by the disk manufacturer.

If your computer came with a factory-installed hard disk, or if you have installed an optional Epson hard disk, it has already been physically formatted. You need only follow the instructions in the MS-DOS Installation Guide to prepare your hard disk for use.

If you have installed a hard disk that came with its own format utility, use that program to physically format the disk.

You may need to use the procedure in this chapter to physically format a hard disk if either of the following is true:

- Your hard disk is producing numerous read/write errors or you are having other serious problems with it. Sometimes, after a hard disk has been used for a long time, its data becomes fragmented, causing the disk to perform less efficiently or produce errors. You may want to reformat the disk in this case.
- You have installed a non-Epson hard disk in your computer that has never received the low-level format and did not come with its own format utility.

Physically formatting a hard disk erases any data it contains. If you are reformatting a hard disk you have been using, be sure to back up all the data on your hard disk to diskettes before you format it. See your MS-DOS Reference Manual for instructions on backing up data.



## Caution

If you are unsure if formatting is necessary, contact your Epson dealer for assistance.

In addition to destroying all the data on the hard disk, formatting removes any partitions and logical formatting defined on the disk by FDISK, SELECT, or FORMAT. After you physically format a new or used hard disk (using option 1 or 2 of the Hard Disk Format Menu), you need to install MS-DOS. Follow the instructions in your MS-DOS Installation Guide. The installation process automatically partitions and formats the hard disk to prepare it for use. (If you are installing another operating system, follow the instructions in the documentation that came with it.)

---

## Choosing the Type of Format

Follow these steps to display the formatting options:

1. Insert the Reference diskette in drive A.
2. Turn on or reset the computer. The computer automatically loads MS-DOS and displays the Operation Menu.
3. Press 2 to highlight Format hard disk and press **Enter**. The Hard Disk Format Menu appears on the screen:

```
HARD DISK FORMAT MENU
1 - Format
2 - Destructive surface analysis
3 - Non-destructive surface analysis
0 - Exit
```

The formatting options work as follows:

- ❑ Format first scans the disk (if it has no defective track table) for defective (bad) tracks and lets you decide which tracks to mark as bad. Then the program formats the disk and marks the bad tracks so they are never used to store data.
- ❑ Destructive surface analysis tests the entire hard disk for read/write errors or unflagged bad tracks and updates the defective track table. Because this option writes and reads data on the disk, it destroys all data on any track that produces an error. You cannot run the Destructive surface analysis on a disk that has never been formatted.
- ❑ Non-destructive surface analysis checks the disk for unflagged bad tracks without destroying data. You cannot run the Non-destructive surface analysis on a disk that has never been formatted.

The type of format you choose depends on whether you are reformatting a disk that has been used or formatting a new disk for the first time. See the recommendations below.

### ***Reformatting a Used Disk***

If you are reformatting a disk you have been using that appears to be damaged, follow these steps:

1. Use the Non-destructive surface analysis test to check for unflagged bad tracks.
2. If errors occur during the Non-destructive surface analysis, back up your hard disk to diskettes. (See your MS-DOS Reference Manual for instructions on backing up data.)
3. Run the Destructive surface analysis.

## ***Formatting a New Disk***

Many hard disk drives come with a printed list of bad tracks but the bad tracks are not flagged on the disk. You may need to modify the defective track table to add the bad tracks. Other hard disks (such as those supplied by Epson) come with the bad tracks already flagged. If you are formatting a new hard disk that has never been formatted, select the Format option to format the disk.

## ***Selecting an Option***

When using this program, you often need to select an option from a menu. There are two ways to do this:

- You can use the arrow keys (**↑ ↓ ← →**) to highlight the option and press **Enter**.
- You can type the number of the option and press **Enter**.

You can select almost any option that appears on the screen using either of these two methods.

## ***Starting the Formatting Process***

If you have more than one hard disk drive, you see this prompt:

```
Enter drive number ? (1/2)
```

Select 1 for the first hard disk or 2 for the second hard disk. Then see the instructions below for the Hard Disk Format Menu option you want to use.

---

## **Option 1, Format**

If you select 1 -Format from the Hard Disk Format Menu, you see the following (for a disk that does not have a defective track table):

```
Format Hard Disk < Drive 1: >
```

```
Scan hard disk to get defective track  
information      ? (Y/N)
```

(If the disk already has a defective track table, you do not see the message because the disk does not need to be scanned for bad tracks.)

Select Y to scan the disk or N to skip the scanning process.

If you select Y, the program scans the disk and displays these messages during the process:

```
Scanning for flagged bad tracks...
```

```
Head : nnn      Cylinder : nnnn
```

You see the head and cylinder numbers decrease as the program progresses. After scanning the disk, the program displays the results, such as the following:

```
Scanning finished.
```

```
Count of tracks flagged bad      =      1  
Count of tracks with other errors =      0  
Count of good tracks             =    4884
```

Next you see the following prompt:

```
Accept recommended skewed sectors in  
format      : 1 ? (Y/N)
```

For an Epson hard disk drive, it is best to accept the recommended skewed sector (also called the interleave factor) of 1. For other hard disk drives, you may need to change this value if the documentation that came with the disk recommends a different number.

To accept the default, select Y.

To enter a new value, select N. You see the following prompt:

```
Enter new skewed sectors in
format (1-16):
```

Enter a number from 1 through 16 that equals the maximum sector number for the drive minus 1. The maximum sector number varies, depending on the drive type. Then press **Enter**.

Next you see this prompt:

```
Accept recommended skewed sectors per
head in format : 0? (Y/N)
```

For an Epson hard disk drive, accept the recommended value of 0. For another type of drive, use the value recommended in the documentation for the drive.

To accept the default, select Y.

To enter a new value, select N. You see the following prompt:

```
Enter new skewed sectors per head
in format (0-16):
```

Enter a number from 0 through 16 which equals the maximum sector number for the drive minus 1. The maximum sector number varies, depending on the drive type. Then press **Enter**.

The program now allows you to edit the defective track table:

| Cylinder | Head | Cylinder | Head | Cylinder | Head | Cylinder | Head | Cylinder | Head |
|----------|------|----------|------|----------|------|----------|------|----------|------|
| nnn      | nn   |          |      |          |      |          |      |          |      |

Defective Track Table:  
Modify defective track table ? (Y/N)

At the bottom of the table is this prompt:

Modify defective track table ? (Y/N)

Select **Y** to add bad tracks to the defective track table. See the next section for instructions.

Select **N** to leave the table as it is. Then skip the following section and go on to “Formatting the Disk” on page B-9.

### ***Modifying the Defective Track Table***

If you select **Y** to modify the table, you see the following options at the bottom of the table:

Defective Track Table : Move box cursor to desired track with cursor key  
A = Add track, C = Change track, D = Delete track, F = Finish editing  
Enter command :

To add a bad track, follow these steps:

1. Press **A**. You see this prompt:

Enter cylinder number (1 -nnnn):

2. Type the number of the cylinder containing the bad track and press **Enter**. You see this prompt:

Enter head number (0 -nn):

3. Type the head number for the bad track and press **Enter**.

To cancel the operation, press **Enter** without typing a value.

When you complete a valid entry, it appears in the table and you can add the next bad track, if necessary.

If you make a mistake, move the cursor block to the incorrect track and press **C** to alter the track data or press **D** to remove the track from the table. Change the track data just as you add a track.

The maximum valid cylinder number and head number (nnnn and *nn*) vary according to the capacity of the hard disk. If you enter an invalid cylinder or head number, a reminder of the range of values appears and the program asks you to enter the value again.

When you finish adding all the bad tracks, press **Enter** without typing a value. After you complete editing, check the entries in the defective track table. When you are sure the table is correct, press **F**. The program displays a warning about the consequences of proceeding with formatting.

## Formatting the Disk

When you are ready to start formatting the disk, you see the following warning:

```
WARNING!  ALL DATA WILL BE DESTROYED IN
ALL PARTITIONS OF HARD DISK, NOT JUST IN
MS-DOS PARTITION!
Do you want to start formatting ? (Y/N)
```

If you are not sure you want to format the hard disk, select N. If you are sure, select Y; the program gives you one more chance to cancel:

```
DOUBLE CHECK THAT YOU HAVE BACKUP
DISKETTE COPIES OF ALL YOUR FILES.
Do you want to exit and check your
file copies ? (Y/N)
```

Select Y to cancel formatting (and check your backups) or N to continue.

If you continue with formatting, you see:

```
Format started.
```

```
Head : nnn    Cylinder : nnnn
```



You see the head and cylinder numbers decrease as the program progresses. When formatting is complete, the program flags any bad tracks and you see a series of messages like these:

```
Format finished.
```

```
Flagging bad tracks...
```

```
Cylinder is nnnn, head is nn
```

```
Format completed.
```

```
Press ENTER to return to the menu.
```

Press **Enter** to return to the Hard Disk Format Menu.

---

## ***Option 2, Destructive Surface Analysis***

You can perform a Destructive surface analysis of your hard disk to accurately locate any bad tracks, and flag any bad tracks that are not flagged.

### **Caution**

If any errors occur during this check, all data on the track that produces the error is destroyed. For this reason, if you think that an unflagged bad track is causing trouble, first run option 3, Non-destructive surface analysis, to check the disk surface.

The Destructive surface analysis operates by a complex process of writing, reading, and verifying information on every track of the hard disk, except for tracks that are already flagged as bad tracks.

To start this test, select 2-Destructive Surface analysis from the Hard Disk Format Menu. You see these messages:

```
Analyze Hard Disk <Drive 1:>
```

```
Read/Save/Write/Read/Restore/Read  
check for all tracks...
```

```
Current cylinder is nnnn
```

As the program checks each track, it counts the cylinder numbers (*nnnn*) down to zero. When the test is complete, the program displays a report on the status of the disk, including a table of unflagged tracks that produced write, read errors-such as the following:

```
Analysis finished.
```

```
Count of tracks flagged bad           =      n  
Count of tracks with write, read errors =      n  
Count of good tracks                  = nnnn
```

```
No write, read error was detected.
```

```
No data was destroyed.
```

```
Press ENTER to return to the menu.
```

If the program finds one bad track that is not flagged, the summary would show one track with a write, read error. The report is followed by a table like this:

| Write, Read Error Tracks |      |          |      |
|--------------------------|------|----------|------|
| Cylinder                 | Head | Cylinder | Head |
| 237                      | 2    |          |      |

Confirm to register the tracks in the Write, Read Error Track Table as bad **tracks**.

Do you want to register the error **tracks** as **bad tracks**? (Y/N)

To flag the error tracks as bad, select Y. YOU see a list of the tracks as they are flagged and these messages:

```
Flagging bad tracks...
```

```
Cylinder is 237, head is 2
```

```
Press ENTER to return to the menu.
```

Press **Enter** to return to the Hard Disk Format Menu.

---

### ***Option 3, Non-destructive Surface Analysis***

The Non-destructive surface analysis does not destroy any data, and you can use it to safely check the condition of your hard disk drive. However, this test does not flag any bad tracks it detects.

To start the test, select 3-Non-destructive surface analysis from the Hard Disk Format Menu. You see these messages:

```
Analyze Hard Disk <Drive 1:>
```

```
Read/Verify check for all tracks...
```

```
Current cylinder is nnnn
```

As the program checks each track, it counts the cylinder numbers down to zero. When the test is complete, the program displays a report on the status of the disk, such as the following:

```
Analysis finished.
```

```
Count of tracks flagged bad           =      n  
Count of tracks with read, verify errors =      n  
Count of good tracks                   =  nnnn
```

```
No read, verify error was detected.
```

If the program finds errors, the screen displays a table of the tracks that gave errors, similar to the one the Destructive surface analysis displays.

After the status reports, you see this message:

Press ENTER to return to the menu.

Check the information displayed. Then press Enter to return to the Hard Disk Format Menu.

---

### ***Exiting the Hard Disk Format Menu***

To leave the Hard Disk Format Menu, select 0 -Exit. The screen displays the Operation Menu.

If you formatted the hard disk with option 1 or 2, you must now install MS-DOS (or another operating system) on the hard disk to prepare it for use. Remove the Reference diskette from drive A and then follow the instructions in your MS-DOS Installation Guide. The installation process automatically partitions and formats the hard disk.

If you only ran the Non-destructive surface analysis, remove the Reference diskette from drive A and press the RESET button to load MS-DOS.

## ***Performing System Diagnostics***

This appendix describes how to check the operation of the main unit and peripheral devices of your computer. You check these devices using the diagnostics program on your Reference diskette.

Run the diagnostics program if you are not sure whether a device is performing correctly. The table at the end of this appendix lists the error messages you may see during testing.

You can test the following devices, each of which is identified by specific reference numbers:

- 1 - System board
- 2 - Memory
- 3 - Keyboard
- 4 - Monochrome display adapter and CRT
- 5 - Color graphics adapter and CRT
- 6 - Diskette drives and controller
- 7 - Math coprocessor
- 9 - Parallel port (printer interface)
- 1 1 - Serial port (RS-232C port)
- 1 2 - Alternate serial port
- 1 4 - Dot-matrix printer
- 1 7 - Hard disk drives and controller
- 2 1 - Alternate parallel port
- 8 1 - Parallel port (on video adapter)

---

## ***Starting System Diagnostics***

To run the System diagnostics program, you must turn on or reset your computer with the Reference diskette in drive A. If you start this program in any other way, some tests may produce strange results.

To start the System diagnostics program, follow these steps:

1. Insert the Reference diskette in drive A.
2. Turn on or reset the computer. The Operation Menu appears.
3. If the **Num Lock** indicator is illuminated, press **Num Lock** to turn off the function.
4. Press 3 or use ↓ to select **System diagnostics** and then press **Enter**.

When you start the System diagnostics program, the computer checks any peripheral devices that are connected to the system. Then you see a list of the devices available for testing. This list includes only the devices that are part of your system; for example:

```
DEVICE LIST

1 - System board
2 - Memory
3 - Keyboard
5 - Color graphics adapter and CRT
6 - Diskette drives and controller
9 - Parallel port (printer interface)
11 - Serial port (RS-232C port)
14 - Dot-matrix printer
17 - Hard disk drives and controller

DEVICE LIST is correct ? (Y/N)
```

If the list correctly describes your system, make sure  $\gamma$  is highlighted and press **Enter**. If a device is missing from this list, or if you want to change the list, press **N** or **→** and **Enter**. Then see “Modifying the Device List” on page C-5.

### **Note**

If your system uses the built-in VGA adapter or an EGA or VGA card with a color monitor, your device list should include item 5, Color graphics adapter and CRT. If your system uses the built-in VGA adapter or an EGA or VGA card with a monochrome monitor, your device list should include item 4, Monochrome display adapter and CRT.

After you confirm the Device List, you can test only those items. If you decide later that you need to add a device, you must return to the Operation Menu and reselect system diagnostics.

### **Note**

After you have installed MS-DOS, you should always boot the computer from your hard disk or from the MS-DOS Startup diskette to use MS-DOS. When you are finished running system diagnostics, remove the Reference diskette from drive A. If you do not have a hard disk, insert the Startup diskette. Then reset your computer to make sure it performs all the commands in the CONFIG.SYS and AUTOEXEC.BAT files.

---

## **Selecting an Option**

When you are using the System diagnostics program, you often need to select an option from a menu. There are two ways to do this:

- ❑ You can use the arrow keys (**↑ ↓ ← →**) to highlight the option you want and then press **Enter** to select it.
- ❑ You can type the number of the desired option and press **Enter** to select it.

For example, you may see this menu:

```
1 - Run test one time
2 - Run test multiple times

0 - Exit
```

Suppose the first option is highlighted. If you want to select that option, just press **Enter** (because it is already highlighted). If you want to select option 2, you can either press **↓** (or **2**; this causes the cursor block to move to that option. Then press **Enter** to select it.

### Note

You can press **Esc** any time you want to leave the menu currently displayed and return to the previous one.



---

## ***Modifying the Device List***

If an installed device is missing from the Device List, you must add it to the list and test it carefully. At the following prompt, select N.

```
DEVICE LIST is correct ? (Y/N)
```

You see this menu:

```
1 - Add device
2 - Delete device

0 - Finish modification
```

To add a device to the list, select 1. The program displays a list of other devices that are not currently included in the Device List. You see a menu similar to this:

```
Additional DEVICE LIST
```

```
4 - Monochrome display adapter and CRT
7 - Math coprocessor
12 - Alternate serial port
21 - Alternate parallel port
81 - Parallel port (on video adapter)

0 - Exit to DEVICE LIST
```

Highlight the item you wish to add and press **Enter**.

You can add as many devices as necessary. When the Device List is complete, select 0 (Exit).

To remove a device from the list, select 2 (Delete device). The screen displays the current Device List.

Select the item you wish to delete. You can delete as many devices as necessary.

When the Device List is correct, select 0. The screen displays the modified Device List for a final check and these options:

```
1 - Add device
2 - Delete device

0 - Finish modification
```

If the list is correct, select 0. You are now ready to select a test.

---

## ***Selecting a Test***

From the Device List, select the device you wish to test. Before the test begins, you are asked how many times to perform the test. You see this menu:

```
Number of times to test device

1 - Run test one time
2 - Run test multiple times

0 - Exit
```

You can specify that the test be performed one time only or any number of times in the range from 1 to 9999. Running a test multiple times is for reliability testing of essential functions only; in most cases, running a test once is sufficient.

To perform the test once, select 1. The program may display a submenu of more detailed tests for the device you are checking.

To perform the test multiple times, select 2. You see this prompt:

```
Terminate checking if an error
detected ? (Y/N)
```

Select **Y** to terminate checking if the device produces an error, or **N** to repeat the tests regardless of an error. You see this prompt:

```
Repeat times (1-9999) ? 1
```

To perform the test once, press **Enter**.

If you wish to run the tests more than once, type the number of times and press **Enter**.

For some devices, the computer does not display a submenu of tests to choose from. Instead, it performs all the tests that do not require you to enter a response. If you chose to test the device more than once, the computer runs all the tests and then repeats them in the same order.

You may see this message on the screen during the tests:

```
On errors, press any key to stop
```

If you see an error while one of the tests is running, press any key to terminate the test.

## ***Resuming From an Error***

If an error occurs during a test, the test stops at that point, and an error code and error message appear. If you want to record the problem, you can print out the message on your printer. You see this prompt:

```
Do you want a printout of the error
message(s) ? (Y/N)
```

To continue without printing the error message, select N .

Before you request a printout, be sure your printer is ready and contains paper. Then select Y . If the printer is not ready, the following message and prompt appear:

```
Printer is not installed correctly.
Install correctly before entering.
Continue ? (Y/N)
```

Correct the problem and select Y to continue printing, or select N to cancel printing.

After printing the error message, the program displays this prompt:

```
Printout is finished. Press ENTER to
return to the menu.
```

The program continues after an error in one of the following ways:

- It returns to the Device List, or
- If you are running multiple tests and are not terminating on an error, the program repeats the test that caused the error.

The table *below* lists the tests you can run on the system's internal devices and on any optional devices *you* have installed. You may not see all of the tests listed when you run System diagnostics. Some tests appear only if you have installed certain types of equipment. The program displays the title of each check on the screen.

Tests that check the operation of parallel or serial ports require you to use a special connector in order to test the device. Contact your dealer to obtain the connector listed in the table below before beginning the tests.

For a complete list of the error codes and messages these tests may display, see the table at the end of this appendix.

system diagnostics tats

| Device                             | Tests available  | Description                                   |
|------------------------------------|--|---|
| System board                       |  | Checks the 80386SX microprocessor             |
| Memory                             |  | Checks all memory and displays a memory count |
| Keyboard                           |  | Tests all keys on the keyboard                |
| Monochrome display adapter and CRT | Adapter check<br>Attribute check<br>Character set check<br>Graphics mode check<br>Screen paging check<br>Video check<br>Sync check<br>Run all above checks | Tests all types of monochrome monitors        |

---

## ***Error Codes and Messages***

The following table lists all the error codes and messages that may appear during system diagnostics testing.

system diagnostics error codes and messages

| <b>Error code</b>   | <b>Message</b>  |
|---------------------|---|
| <b>System board</b> |   |
| 101                 | CPU ERROR   |
| 102                 | ROM CHECKSUM ERROR                                    |
| 103                 | TIMER COUNTER REGISTER ERROR                          |
| 104                 | TIMER COUNTER ERROR                                   |
| 105                 | DMA CONTROLLER REGISTER ERROR                         |
| 105                 | REFRESH ERROR   |
| 106                 | DMA PAGE REGISTER ERROR                               |
| 107                 | KEYBOARD CONTROLLER TIMEOUT ERROR                     |
| 108                 | KEYBOARD CONTROLLER SELF DIAGNOSTIC<br>ERROR          |
| 108                 | KEYBOARD CONTROLLER WRITE COMMAND<br>ERROR            |
| 109                 | INTERRUPT CONTROLLER ERROR                            |
| 110                 | CMOS SHUTDOWN BYTE ERROR                              |
| 111                 | CMOS BATTERY ERROR                                    |
| 112                 | CMOS CHECKSUM ERROR                                   |
| 113                 | CPU INSTRUCTION ERROR                                 |
| 114                 | PROTECT MODE ERROR 1                                  |
| 115                 | PROTECT MODE ERROR 2                                  |
| <b>Memory</b>       |   |
| 201                 | MEMORY ERROR  |
| <b>Keyboard</b>     |   |
| 301                 | 8042 ERROR  |
| 301                 | KEYBOARD ERROR  |
| 302                 | KEYBOARD IS NON-STANDARD, OR KEYBOARD<br>IS DEFECTIVE |

## System diagnostics tests (continued)

| Device                                   | Tests available   | Description  |
|--|---|--|
| Dot-matrix                               |   | Tests the operation of a dot-matrix printer in several modes; requires the printer to be loaded with paper |
| Hard disk drive(s) and controller        | Seek check<br>Write, read check<br>Read, verify check<br>Run all above checks | Tests the operation of the hard disk drive(s)  |
| Alternate parallel port (on option card) |   | Tests the secondary parallel port; similar to primary parallel port test                                   |
| Parallel port on a video adapter         |   | Tests the parallel port included on a video adapter; requires a loop-back connector (contact your dealer)  |

## System diagnostics tests (continued)

| Device                                 | Tests available   | Description  |
|--|---|--|
| Color graphics adapter and CRT         | Adapter check<br>Attribute check<br>Character set check<br>Graphics mode check<br>Screen paging check<br>Light pen check<br>Video check<br>Sync check<br>Run all above checks | Tests all types of color monitors  |
| Diskette drive(s) and controller       | Sequential seek check<br>Random seek check<br>Write, read check<br>Disk change check<br>Run all above checks  | Tests operation of the diskette drive(s); requires a formatted diskette for some tests |
| Math coprocessor                       |   | Tests the operation of the math coprocessor  |
| Parallel port (printer interface)      |   | Tests the primary parallel port; requires a loop-back connector (contact your dealer)  |
| Serial port (RS-232C)                  |   | Tests the primary serial port; requires a loop-back connector (contact your dealer)    |
| Alternate serial port (on option card) |   | Tests the secondary serial port; similar to primary serial port test                   |



System diagnostics error codes and messages (continued)

| <b>Error code</b>                         | <b>Message</b>                              |
|---|---|
| <b>Monochrome display adapter and CRT</b> |   |
| 401                                       | ERROR IN ADAPTER CHECK                      |
| 403                                       | ERROR IN ATTRIBUTE CHECK                    |
| 404                                       | ERROR IN CHARACTER SET CHECK                |
| 406                                       | ERROR IN GRAPHICS MODE CHECK                |
| 408                                       | ERROR IN SCREEN PAGING CHECK                |
| 409                                       | ERROR IN LIGHT PEN CHECK                    |
| 410                                       | ERROR IN VIDEO CHECK                        |
| 411                                       | ERROR IN SYNC CHECK                         |
| <b>Color graphics adapter and CRT</b>     |   |
| 501                                       | ERROR IN ADAPTER CHECK                      |
| 504                                       | ERROR IN CHARACTER SET CHECK                |
| 506                                       | ERROR IN COLOR GRAPHICS CHECK               |
| 508                                       | ERROR IN SCREEN PAGING CHECK                |
| 509                                       | ERROR IN LIGHT PEN CHECK                    |
| 510                                       | ERROR IN COLOR VIDEO CHECK                  |
| 511                                       | ERROR IN SYNC CHECK                         |
| <b>Diskette drive(s) and controller</b>   |   |
| 601                                       | DISKETTE DRIVE CONTROLLER ERROR             |
| 602                                       | SEQUENTIAL SEEK ERROR                       |
| 603                                       | RANDOM SEEK ERROR                           |
| 604                                       | WRITE ERROR                                 |
| 605                                       | READ ERROR                                  |
| 606                                       | DISK CHANGE CHECK REMOVE ERROR              |
| 607                                       | DISK CHANGE CHECK INSERT ERROR              |
| <b>Math coprocessor</b>                   |   |
| 701                                       | COPROCESSOR NOT INSTALLED                   |
| 702                                       | COPROCESSOR INITIALIZE ERROR                |
| 703                                       | COPROCESSOR INVALID OPERATION<br>MASK ERROR |
| 704                                       | COPROCESSOR ST FIELD ERROR                  |
| 705                                       | COPROCESSOR COMPARISON ERROR                |
| 706                                       | COPROCESSOR ZERO DIVIDE MASK ERROR          |
| 707                                       | COPROCESSOR ADDITION ERROR                  |
| 708                                       | COPROCESSOR SUBTRACTION ERROR               |
| 709                                       | COPROCESSOR MULTIPLICATION ERROR            |
| 710                                       | COPROCESSOR PRECISION ERROR                 |

## System diagnostics error codes and messages (continued)

| Error code                               | Message                           |
|--|-----------------------------------|
| <b>Parallel port (printer interface)</b> |                                   |
| 901                                      | ERROR PIN p                       |
| <b>Serial port (RS-232C port)</b>        |                                   |
| 1101                                     | control signal ALWAYS LOW         |
| 1101                                     | <i>control signal</i> ALWAYS HIGH |
| 1102                                     | TIMEOUT ERROR                     |
| 1103                                     | VERIFY ERROR                      |
| <b>Alternate serial port</b>             |                                   |
| 1201                                     | <i>control signal</i> ALWAYS LOW  |
| 1201                                     | <i>control signal</i> ALWAYS HIGH |
| 1202                                     | TIMEOUT ERROR                     |
| 1203                                     | VERIFY ERROR                      |
| <b>Dot-matrix printer</b>                |                                   |
| 1401                                     | status                            |
| <b>Hard disk drive(s) and controller</b> |                                   |
| 1701                                     | SEEK ERROR                        |
| 1702                                     | WRITE ERROR                       |
| 1703                                     | READ ERROR                        |
| <b>Alternate parallel port</b>           |                                   |
| 2101                                     | ERROR PIN p                       |
| <b>Parallel port (on video adapter)</b>  |                                   |
| 81nn                                     | ERROR PIN p                       |

## **Specifications**

### **CPU and Memory**

|                             |   |
|-----------------------------|---|
| CPU                         | 80386SX microprocessor, 20 MHz system clock speed, 20 MHz or simulated 8 MHz processor speed, selectable through software or keyboard command<br><br>0 wait state memory access speed at 20 MHz |
| System memory               | 2MB RAM standard; base memory of 640KB<br><br>Memory expandable using 256KB, 1MB, or 4MB SIMMs up to 14MB (maximum); SIMMs must be fast-page mode, 80ns access speed (or faster)                |
| ROM                         | 128KB (includes system BIOS and VGA BIOS)   |
| Shadow RAM                  | 0 wait state access speed; automatically copies both ROM BIOS and video ROM into RAM  |
| Cache controller            | A38202SX (20MHz) standard   |
| Cache RAM                   | 32KB high-speed (25ns) static RAM   |
| Math coprocessor (optional) | 80387SX (20 MHz) support  |
| Clock/calendar              | Real-time clock, calendar, and 114-byte CMOS RAM for configuration; battery backup  |

## **Controllers**

|           |   |
|-----------|---|
| Diskette  | Supports up to two drives in any of four formats: 5 <b>1/4-inch</b> , high-density, 1.2MB; 5 <b>1/4-inch</b> , double-density, 360KB; 3 <b>1/2-inch</b> , high-density, 1.44MB; or 3 <b>1/2-inch</b> , double-density, 720KB; controller on main system board |
| Hard disk | Supports up to two half-height drives; embedded controller; interface on main system board  |

## **Interfaces**

|              |   |
|--------------|---|
| Monitor      | VGA adapter with 512KB DRAM (video memory) built into main system board; supports up to 800 x 600 pixels in 16-colors or up to 640 x 480 pixels in 256-colors; multi-frequency monitor required for resolutions over 640 x 480<br><br>15-pin, D-shell connector |
| Serial       | RS-232C, programmable, asynchronous; 9-pin, D-shell connector   |
| Parallel     | Standard 8-bit parallel, mono-directional; 25-pin, D-shell connector  |
| Mouse port   | Mini DIN, 6-pin connector for PS/2 compatible mouse or other device   |
| Keyboard     | Mini DIN, 6-pin connector for PS/2 compatible keyboard  |
| Option slots | Four standard input/output expansion slots (three 16-bit ISA compatible and one 8-bit ISA compatible); 8 MHz bus speed  |

Speaker Internal; operation controllable by software

## ***Power Supply***

**Type** 140W, f&cooled, automatic (worldwide) input voltage sensing

**Input ranges** 98 to 132 VAC and 195 to 264 VAC

**Maximum outputs** +5 VDC at 18 Amps, +12 VDC at 4.2 Amps

-12 VDC at 0.3 Amps, -5 VDC at 0.3 Amps

+ 12 VDC at 6 Amps, peak ( 10 seconds)

## ***Mass Storage***

Up to three half-height drives maximum (one vertical mount and two horizontal mounts) configurable using any of the following drive types (only horizontal mounts can be accessed externally):

**Diskette drives** 5 **1/4-inch** diskette drive, 1.2MB (high-density) storage capacity

3 **1/2-inch** diskette drive, 1.44MB (high-density) storage capacity

5 **1/4-inch** diskette drive, 360KB (double-density) storage capacity

3 **1/2-inch** diskette drive, 720KB (double-density) storage capacity

Hard disk drives 3 **1/2-inch** form factor hard disk drive(s); up to half-height size; first drive mounted vertically, second mounted horizontally

## **Keyboard**

Detachable, two position, 101 sculpted keys

### **Layout**

58-key QWERTY main keyboard; 17-key numeric/cursor pad; 10 cursor keys; additional 4-key cursor pad; 16 function keys (user-definable)

### **Function**

Four levels (normal, shift, control, alternate); user-definable

## **Environmental Requirements**

**A -**  
**-7**

| <b>Condition</b>                 | <b>Operating range</b>              | <b>Non-operating range</b>           | <b>Storage range</b>                        |
|----------------------------------|-------------------------------------|--------------------------------------|---|
| <b>Temperature</b>               | 41° to 95° F<br>(5° to 35° C)       | -4° to 140° F<br>(-20° to 60° C)     | <del>40° to 140° F</del><br>(-40° to 60° C) |
| <b>Humidity (non-condensing)</b> | 20% to 80%                          | 10% to 90%                           | 5% to 95%                                   |
| <b>Attitude</b>                  | -330 to 9900 ft<br>(-100 to 3000 m) | -330 to 11880 ft<br>(-100 to 3600 m) | -330 to 39600 ft<br>(-100 to 12000 m)       |
| <b>Maximum wet bulb</b>          | 68° F<br>(20° C)                    | 104° F<br>(40° C)                    | 134° F<br>(57° C)                           |

## ***Physical Characteristics***

|                                 |   |
|---------------------------------|---|
| Width                           | 15 inches (374 mm)                                |
| Depth                           | 16.75 inches (419 mm)                             |
| Height                          | 6 inches (151 mm)                                 |
| Weight<br>(without<br>keyboard) | Single diskette drive model:<br>20.75 lb (9.4 kg) |

---

# ***Glossary***

## **Address**

A number or name that identifies the location where information is stored in a computer's memory.

## **Analog monitor**

A monitor that generates, responds to, or acts upon analog data. Analog data is transmitted by varying the voltage levels in a continuous current.

## **Application program**

A software program designed to perform a specific task, such as a word processing or spreadsheet program.

## **ASCII**

American Standard Code for Information Interchange. A standardized coding system for representing characters, such as numbers, letters, and graphic symbols. An ASCII character occupies one byte of storage. Many different computers, printers, and programs can use files transmitted in ASCII code.

## **Asynchronous**

A method of data transmission in which one machine sends data one character at a time to another machine at irregular intervals that do not need to be synchronized to a timing device.

## **AUTOEXEC.BAT file**

The batch file that is executed automatically when you load MS-DOS. See also Batch file.



## **Automatic speed**

The feature that enables the computer to switch automatically from high speed (20 MHz) to low speed (simulated 8 MHz) when accessing a diskette drive.

## **Backup**

An extra copy of a program, data file, or disk, that you should create in the event your working copy is damaged or lost.

## **Base memory**

The memory in the computer below 1MB that is available to MS-DOS and application programs-usually 640KB. Also called conventional memory or main memory.

## **Batch file**

A type of file that lets you execute a series of MS-DOS commands by typing one command. Batch files are text files with the filename extension .BAT. In a batch file, each command is entered on a separate line. When you type the filename, MS-DOS executes all the commands in that file sequentially.

## **B I O S**

Basic Input/Output System. Routines in ROM (Read Only Memory) that handle basic input/output functions of the operating system. Usually called ROM BIOS.

## **Bit**

A binary digit (0 or 1). The smallest unit of computer storage. The value of a bit represents the presence (1) or absence (0) of an electric charge.

## **Boot**

To load the operating system into the computer's memory.

## **Byte**

A sequence or group of eight bits that represents one character.

## **Cache memory**

A high-speed type of memory buffer that stores information from base or extended memory where your system can access it faster.

## **CGA**

Color Graphics Adapter. A type of display adapter card that can generate up to 25 lines of text with 80 characters on each line, monochrome graphics at 640 x 200 resolution, or four-color graphics at 320 x 200 resolution.

## **Character**

Anything that can be printed in a single space on the page or the screen; includes numbers, letters, punctuation marks, and graphic symbols.

## **CMOS**

Complementary Metal-Oxide Semiconductor. A type of low-power silicon chip. Information defined by the Setup program is stored in **CMOS** RAM, which is backed up by a battery. Whenever you turn on the computer, it searches **CMOS** RAM for the configuration information.

## **Code**

A system of symbols for representing data or instructions. Also any software program or part of a program.

## **Command**

An instruction you enter (usually on a keyboard) to direct your computer to perform a specific function.

## **Command prompt**

The symbol or message that tells you **MS-DOS** is loaded and ready to receive instructions. The default command prompt displays the current drive and directory. If you are logged onto drive C, the command prompt may look like this: **C:>**.

## **Configuration**

The particular setup of a group of components. A typical system configuration consists of a computer with one diskette drive, one hard disk drive, and a monitor, connected to a printer.

## **Control code**

A command (generated when you hold down **Ctrl** and press another key on the keyboard) that instructs the computer to perform a specific function.

## **Conventional memory**

The memory in your computer (up to 640KB) used by MS-DOS and application programs. Also called base memory or main memory.

## **Coprocessor**

An optional device that enables the computer to process certain mathematical calculations faster.

## **Copy-protected program**

A type of program that cannot be copied. Some copy-protected programs require you to leave the program diskette in the diskette drive while you are using it. Some also require the computer to be running at low speed (simulated 8 MHz) instead of high speed (20 MHz). **See also** Automatic speed.

## **CPU**

Central Processing Unit. The primary unit of the computer that interprets instructions, performs the tasks you indicate, keeps track of stored data, and controls all input and output operations.

## **Cursor**

The highlighted marker that shows your position on the screen.

## **Cylinders**

The vertical alignment of tracks in a hard disk that can be lined up under one read/write head. The number of tracks on a disk is equal to the number of cylinders times the number of heads.

## **Data**

Information, such as text or graphics, stored or processed by a computer.

## **Data diskette**

A formatted diskette on which you store data files (as opposed to program files).

## **Default**

Any value or setting that takes effect when the computer is turned on or reset. A default value stays in effect unless you override it temporarily by changing a setting or you reset the default value itself.

## **Delimiter**

A character or space used to separate different parts of an MS-DOS command.

## **Device**

A piece of equipment that is part of a computer system and performs a specific task, such as a disk drive, a monitor, or a printer.

## **Device driver**

A file containing instructions that allow your computer to recognize and control a device. The Equity 386SX/20 PLUS comes with device drivers that provide super VGA features for various programs when used with a multi-frequency monitor.

## **Diagnostics**

The tests and procedures the computer performs to check its internal circuitry and set up its configuration.

## **DIP switch**

Dual Inline Package switch. A small switch on a computer, option card, or printer that controls a particular function.

## **Directory**

A list of files stored in a particular area on a disk; part of a structure for organizing files into groups. A directory listing shows the name, location, and size of the files in the directory. A directory can contain both files and subdirectories.

## **Disk**

The collective term for diskettes and hard disks.

## **Disk drive**

The physical device that allows the computer to read from and write to a disk. A diskette drive has a disk slot into which you insert a diskette. A hard disk is sealed inside a protective unit.

## **Diskette**

A flat piece of flexible plastic coated with magnetic material used to store data permanently. Available in either 3 1/2-inch or 5 1/4-inch format.

## **Display adapter card**

A circuit board that can be installed in one of the computer's option slots to provide the monitor interface. The display adapter card controls the way the monitor displays text and graphics. (In the Equity 386SX/20 PLUS, a VGA display adapter is built into the system board. Also known as Video card.

## **DOS**

Disk Operating System. A commonly used operating system that controls the computer's input and output functions. See Operating system

## **Double-density**

A type of diskette format that allows you to store twice as much data as the standard-density format. A 5 1/4-inch double-density diskette can store 360KB of data. A 3 1/2-inch double-density diskette can store 720KB of data.

## **Drive designator**

The letter name of a disk drive, followed by a colon-for example, **C:**

## **EGA**

Enhanced Graphics Adapter. A type of display adapter card that allows you to display high-resolution graphics on a compatible monitor. It can display up to 43 lines of text with 80 characters on each line, or it can display monochrome or 16-color graphics at up to 640 x 350 resolution.

## **Expanded memory**

Memory that specially written MS-DOS application programs can use with an Expanded Memory Specification (**EMS**) device driver such as EMM386.SYS.

## **Extended Memory**

Memory above 1MB that is accessed by the protected mode of the 80386SX microprocessor and is available to some application programs and operating systems.

## **Extension**

A suffix of up to three characters that you can add to a filename to better identify it.

## **File**

A group of related pieces of information called records, or entries, stored together on a disk. Text files consist of words and sentences. Program files consist of codes and are used by computers to interpret and carry out instructions.

## **Filename**

A name up to eight characters long that MS-DOS uses to identify a file.

## **Fixed disk**

See **Hard disk**.

## **Format**

To prepare a new disk (or an old one you want to reuse) so that it can store information. Formatting divides a disk into tracks and sectors and creates addressable locations on it.

## **Graphics**

Lines, angles, curves, and other nonalphanumeric data.

## **Hard disk**

The enclosed unit used to store large amounts of data. Unlike a diskette, it is fixed in place. It can process data more rapidly and store many more files than a diskette. Also called fixed disk.

## **Hardware**

Any physical component of a computer system, such as a monitor, printer, keyboard, or CPU.

## **High-density**

A type of format that allows you to store more data than on single- or double-density diskettes. A 5 <sup>1</sup>/<sub>4</sub>-inch high-density diskette can store 1.2 MB of data. A 3 <sup>1</sup>/<sub>2</sub>-inch high-density diskette can store 1.44 MB of data.

## **Input/output (I/O) port**

See **Port**

## **Interface**

A physical or software connection used to transmit data between equipment or programs.

## **Interlaced mode**

The mode in which a monitor scans every other line with each pass of its beam alternating between even numbered lines and odd numbered lines. This technique achieves doubling of the frame rate while keeping the bandwidth down.



## **Interleave factor**

The number of physical sectors on a disk drive that the computer skips when reading consecutive logical sectors the same track. An interleave factor of 1:1 indicates that the data is stored on the drive in adjacent sectors. Larger ratios indicate that the data is not stored sequentially.

## **Jumper**

A small device that connects two pins on an option card, a disk drive, or the main system board to activate a particular function.

## **Key disk**

A diskette containing a copy-protected program that must remain in the diskette drive while you are using the program.

## **Kilobyte (KB)**

A unit used to measure storage space in a computer's memory or on a disk. One kilobyte equals 1024 bytes.

## **LIM 4.0 EMS**

Version 4.0 of the Lotus/Intel/Microsoft Expanded Memory Specification—a protocol that allows certain application programs to use memory that MS-DOS cannot use.

## **Main system board**

The board built into your computer containing the circuitry that the computer requires to operate.

## **Math coprocessor**

An optional device that enables the computer to process certain mathematical calculations faster.

## MCGA

Multi-Color Graphics Array. This mode provides CGA compatibility as well as two-color **640** x **480** and 256-color **320x200** modes.

## MDA

Monochrome Display Adapter. A type of display adapter that displays text in only one color, such as green or amber.

## Megabyte (MB)

A unit used to measure storage space in a computer's memory or on a disk. One megabyte equals 1024KB.

## Megahertz (MHz)

A unit used to measure oscillation frequency (of a computer's internal timing clock). A megahertz is one million cycles per second. The Equity 386SX/20 PLUS operates at 20 MHz or simulates an 8 MHz operating speed.

## Memory

The area where your computer stores data. Memory contents can be permanent (**ROM**) or temporary (**RAM**).

## Memory module

A small circuit board that contains memory chips. You can add 256KB, 1MB, or 4MB memory modules to the main system board inside the computer to expand the computer's memory. A memory module is commonly called a SIMM (single inline memory module).

## Memory on card

The additional memory on an option card installed in the computer.

## **MGA**

Multi-mode Graphics Adapter. A type of display adapter card that can display monochrome text and color graphics on the screen.

## **Microprocessor**

A small version of a CPU contained on one semiconductor chip.

## **Modem**

A device that allows a computer to transmit signals over telephone lines so it can send and receive data. Modem stands for MODulator/DEModulator.

## **Monitor**

The piece of hardware that contains the screen and displays information.

## **Monochrome monitor**

A monitor that displays in only one color, such as green or amber, as opposed to a color monitor which can display in several colors.

## **Mouse**

A hand-held pointing device with one or more buttons. When you slide the mouse over a flat surface in a certain direction, the cursor moves in the same direction on the screen.

## **MS-DOS**

Microsoft Disk Operating System. The operating system most commonly used with your computer. See Operating system.

## **Multi-frequency monitor**

A monitor that allows variable horizontal and vertical sync frequencies. This type of monitor supports a large range of video display modes and is required to support the 800 x 600 super graphics mode.

## **Network server**

The master computer in a network which provides storage space for the other computers connected to it. The network server can write files to and read files from the other computers in the network.

## **Network server mode**

An optional password mode that provides extra security for a computer that is operating as a network server.

## **Noninterlaced mode**

A technique used by the built-in VGA display adapter that refreshes all the lines on the monitor screen sequentially from top to bottom.

## **Numeric keypad**

The number keys grouped to the right of the keyboard.

## **Operating speed**

The speed at which the central processing unit can execute commands. The Equity 386SX/20 PLUS can run at 20 MHz or simulate an 8 MHz operating speed.

## **Operating system**

A collection of programs (such as MS-DOS, MS OS/2, or Unix) that manages a computer's operations. The operating system determines how programs run on the computer and supervises all input and output.

## **Option card**

A circuit board you install inside the computer to provide additional capabilities, such as a modem.

## **Parallel**

The type of interface that transmits all the bits in a byte of data simultaneously over separate lines. See **Interface** and **Serial**.

## **Parameter**

A qualifier added to a command that tells MS-DOS what particular conditions to look for and specifies information such as what data you want to process and where to locate or store a file.

## **Parity**

A method used to verify the accuracy of data transmissions by adding a bit that makes the total of the byte odd for odd parity or even for even parity.

## **Partition**

( 1 ) The area defined on a hard disk for use by an operating system; (2) to divide a hard disk into separate sections or logical drives. You can define a primary partition and one or more extended partitions on a hard disk.

## **Pathname**

The list of directories and subdirectories you specify to locate a file. For example, the pathname for the file SALES, which is located in the subdirectory BUSINESS of the root directory ( \ ), is \ BUSINESS \ SALES.

## **Peripheral**

An external device (such as a printer or a modem) connected to a computer that depends on the computer for its operation.

## **Port**

A physical input/output socket on a computer where you can connect a peripheral device.

## **Power-on diagnostics**

Tests that the computer runs to check its internal circuitry and configuration each time you turn it on.

## **Power-on password**

The sequence of characters you type after you turn on the computer in order to access and use your system. A power-on password can be up to seven characters long and can include letters, numbers, and blank spaces.

## **Processor speed**

*See Operating speed*

## **Program**

A disk file that contains coded instructions and tells a computer what to do and how to do it.

## **Prompt**

A message the screen displays to request information or tell you what action you need to perform next. See also Command prompt.

## **RAM**

Random Access Memory. The portion of the computer's memory used to run programs and store data while you work. All data stored in RAM is erased when you turn off or reset the computer; so you must store any data you want to keep on a diskette or hard disk.

**Read**

To move data from one area to another. For example, when you open a text file stored on disk, the computer reads the data from the disk and displays it on the screen.

**Read/write head**

The physical device inside a disk drive that reads and records data on the magnetic surface of a disk.

**Real-time clock**

A battery-powered clock inside the computer that keeps track of the time and date, even when the computer is turned off.

**Reset**

To reload a computer's operating system so you can retry a task or begin using a different operating system. Resetting erases all information in RAM.

**RGB**

Red Green Blue. A type of color monitor.

**ROM**

Read Only Memory. A portion of memory that can only be read and cannot be used for temporary storage. ROM retains its contents even when you turn off the power.

**Root directory**

The top-level directory in MS-DOS, designated by a \ (backslash). All other directories are subdirectories of the root directory or of other subdirectories.

## **RS - 232 C**

A widely used, standard type of serial interface. You can easily connect an RS-232C compatible device to the built-in port on your computer.

### **Sector**

A contiguous section of a disk track that provides an address at which the computer can access data.

### **Self test**

The initial diagnostics procedures a system performs to check its hardware.

### **Serial**

The type of interface that transmits data one bit at a time. See ***Interface and Parallel.***

### **Shadow RAM**

The feature provided by the Equity 386SX/20 PLUS that enables the computer to copy the ROM BIOS and video ROM into the RAM area of memory to speed up processing.

### **SIMM**

See Memory module.

### **Software**

The programs that enable your computer to perform the tasks and functions you indicate.

### **Subdirectory**

A directory or group of files that branches down from another subdirectory or from the root directory.



## **Super VGA mode**

Special features of the built-in VGA adapter available when you are using certain display drivers and a multi-frequency monitor. These features include 132 column text mode and resolutions up to 800 x 600 in 16 colors.

## **Switch**

An option added to an MS-DOS command that modifies the way the command works. Switches are usually preceded by a / (forward slash). For example, if you add the IS switch to a FORMAT command, MS-DOS installs the operating system on the diskette as it formats it. See **Parameter**.

## **System diagnostics**

A series of checks you can perform on the computer to make sure the hardware is functioning correctly.

## **System diskette**

A diskette that contains the operating system.

## **Tracks**

Addressable, concentric circles on a disk, resembling the grooves on a record, which help to divide the disk into separate accessible areas. There are 80 tracks on each side of a double-sided 1.2MB, 1.44MB, or 720KB diskette and 40 tracks on each side of a double-sided 360KB diskette. The number of tracks on a hard disk depends on its capacity.

## **VGA**

Video Graphics Array. A type of high-resolution display adapter. The VGA adapter built into the system board of your computer can display 16-color graphics at resolutions up to 800 x 600 or 256-color graphics at resolutions up to 640 x 480.

**Video card**

A display adapter card that can be installed in one of the computer's option slots to provide a monitor interface. Your computer comes with a built-in VGA adapter, so you do not need to install a video card in your system if you are going to use this interface.

**Write**

To store data on a disk.

**Write-protect**

To protect the data on a diskette from being changed by placing a write-protect tab over the notch on the side of a  $5\frac{1}{4}$ -inch diskette or by setting the write-protect switch on a  $3\frac{1}{2}$ -inch diskette. When a diskette is write-protected, you cannot erase, change, or record over its contents.

---

# ***Index***

## **A**

AFDD program, 3-2, 4-7-9  
Alternate parallel port check,  
    C-11  
Alternate serial port check, C-10  
Analog monitor, 4-12  
AUTOEXEC.BAT, 1-14,2-30,  
    4-1-2  
Automatic configuration, 2-2  
Automatic speed change,  
    2-12-14, 4-2-7  
Auxiliary device problems, A-26

## **B**

Backing up data,  
    from diskettes, 3-21 -22  
    on hard disk, 3-22-23  
    with BACKUP, 3-22  
    with DISKCOPY, 3-21

BACKUP, 3-22

Base memory, 2-2, 2-28

Batch files, 4-1-2

    AUTOEXEC.BAT, 2-30,  
    4-1-2

Break, 3-4

## **C**

Cable,  
    diskette drive, 5-7, 5-13,  
        7-26 -28  
    hard disk drive, 5-7,5-14,  
        7-13-14, 7-19-20, 7-28-30,  
        A-21  
    power supply, 7-15-16,  
        7-31-32  
    printer, 1-8-11

Cache, 2-11-12, D-1

Cards,

    display adapter, see Video cards  
    memory, 6-1  
    video, see Video cards

CEG, Intro-2-3,4-13

    utilities, Intro-3,4-13

CGA card, see Video cards

Clock, real-time, 2-16-18, D-1

Clock/calendar RAM, D-1

CMOS RAM, 2-1, D-1

Color graphics adapter and CRT  
    check, C-1, C-10

Color graphics adapter (CGA) card,  
    see Video cards

Command, stopping, 3-5

CONFIG.SYS, 1-14,2-30

Connecting,

    keyboard, 1-12-13  
    modem, 1-11  
    monitor, 1-4-8  
    mouse, 1-13-14  
    power cord, 1-2,1-15-16  
    printer, 1-8-11

Consumer Information Center  
    number, Intro-5, A-1

Continuous Edge Graphics, see CEG

Control codes,

    CFRL ALT +, 4-4-5  
    CTRL ALT -, 4-4-5  
    CTRL ALT \*, 4-4-5  
    CTRL ALT DEL, 3-6  
    CTRL BREAK, 3-5  
    CTRL C, 3-5

Controllers, D-2

COPY, 3-2, 3-14, 3-21,4-1

## Copying

diskettes, 3-14, 3-21

files, 3-2, 3-21-23

Coprocessor, see Math coprocessor

Copy-protected programs, 4-3

Cover,

removing, 5-24

replacing, 5-1617

CPU, D-1

CPU speed, see Processor speed

CTRL, 3-3

CTRL ALT +, 4-4-5

CTRL ALT -, 4-4-5

CTRL ALT \*, 4-4-5

CTRL ALT DEL, 3-6

CTRL BREAK, 3-5

CTRL C, 3-5

Cursor block, 2-5-6

## D

DATE, 2-16

Date, setting, 2-16-18

Destructive surface analysis, B-2-3,

B-10-12

Device drivers, Intro-2-3, 4-13

Diagnostics,

power-on, A-2-5

system, C-1-14

DISKCOPY, 3-14,3-21

Diskette drive,

cable, 5-7, 5-13, 7-26 -28

caring for, 3-14-15

compatibility, 3-12-14

configuring, 2-25-26

controller check, C-10

inserting diskettes, 3-19-20

installing, 7-1-3,7-23-32

problems, A-1 8-19

protector card, 1-3,1-16,3-24

reassigning, 4-7-9

removing, 7-33-35

Diskette drive,

removing diskettes, 3-19-20

setting types, 2-25-26

single, 3-18-19

specifications, D-2-3

types, 3-12-14

using, 3-10-22

Diskettes,

backing up, 3-21-22

caring for, 3-14-15

choosing, 3-12-13

compatibility, 3-12-14

copying, 3-14,3-21-22

formatting, 3-13, 3-21

how they work, 3-10-12

inserting, 3-19-20

labelling, 3-15

problems, A- 15-18

read/write slot, 3-15,3-19

removing, 3-19-20

storing, 3-15

system, 3-1, 3-19, 3-23

types, 3-12-13

write-protecting, 3-16-17

Display adapter, see VGA port

Display adapter cards, see Video cards

Display screen, see Monitor

Dot-matrix printer check, C-11

Double-density diskettes, 3-13

Double-sided diskettes, 3-12-13

Drives,

see Diskette drive

see Hard disk

## E

EDLIN, 4-1-2

EGA card, see Video cards

EMM386.SYS, 4-12

Enhanced graphics adapter, see Video cards

Environmental requirements, D-4  
Epson Consumer Information  
Center number, Intro-5, A-1  
Error codes and messages, 2-4-5,  
A-2-5, C-12-14  
ESPEED program, 3-2, 4-3-6  
Expanded memory, 4-11-12  
Extended memory, 2-2, 2-28,  
4-11-12

## F

FDISK, B-2

Files,

AFDD.EXE, 3-2, 4-7-9  
AUTOEXEC.BAT, 1-14,  
2-30, 4-1-2  
backing up, 3-21-23  
batch, 4-1-2  
CONFIG.SYS, 1-14,2-30  
copying, 3-2, 3-21-23  
EMM386.SYS, 4-12  
ESPEED.EXE, 3-2, 4-3-6

Floppy disk drive, see Diskette  
drive

Floppy disks, see Diskettes

FORMAT, 3-21, B-2

Formatting,

diskettes, 3-21  
hard disk, 3-22, B-1-13  
physical, B-1-13

## H

Hard disk, see also Diskette drive

backing up, 3-23  
configuring, 2-19 -24  
drive and controller check,  
C-11  
drive cable, 5-7, 5-14,  
7-13 -14, 7-19-20, 7-28-30,  
A-21

Hard disk,

formatting, 3-22, B-1 -13  
installing, 7-1-35  
installing MS-DOS on, 3-1  
jumpers, 7-4-7  
master drive, 7-4 -6  
mounting frames, 7-8 -9  
mounting plate, 7-10-12  
parking the heads, 3-23-24  
partitions, 3-22, B-2, B-13  
physically formatting, B-1 -13  
precautions, 3-23  
preparing for moving, 3-23-24  
preparing for use, 3-22  
problems, A- 19-23  
removing, 7-1-35  
setting types, 2-19-24  
slave drive, 7-4-6  
specifications, D-2-4  
storage capacity, 3-22  
types, 2-23-24

HDSIT, 3-2, 3-23-24

HELP program, Intro-3

Help, where to get, Intro-5, A-1

Hercules card, see Video cards

High-density diskette, 3-12

## I

Identifying your system, A-1 -2

Initial num lock, 2-14-16

Inserting diskettes, 3-19-20

Interfaces, D-2 -3

Interleave factor, B-6

## J

Jumper settings, 5-1, 6-2-4,  
changing, 6-24

## K

### Keyboard,

- adjusting angle, 1-13
  - cable, 1-12
  - check, C-9
  - connecting, 1-12-13
  - controller check, A-2
  - interface, D-2
  - layout, 3-3, D-4
  - problems, A- 12-13
  - repeat rate, 2-14-16
  - special keys, 3-3-4
  - speed commands, 4-4-5
- Key prompt, 2-9, 3-7-9, 4-10

## L

- LIM 4.0 EMS, 4-11
- Loading MS-DOS, 3-18-19
- Location, choosing for computer, 1-1-2
- Low-level format, see Physical formatting

## M

- Mass storage, D-3-4
- Master drive, 7-4-6
- Math coprocessor,
  - check, C-10
  - configuring, 2-2,2-29
  - installing, Intro-2,6-2, 6-19-22
  - problems, A-27-28
  - removing, 6-22
  - specification, D-1
- MCGA card, see Video cards
- MDA card, see Video cards
- Memory,
  - base, 2-2,2-28
  - beyond 640KB, 4-11-12
  - caching, Intro 1,2-11 -12
  - cards, 6-1
  - check, C-9

- Memory,
  - configuration, 2-2, 2-11-12, 2-28
  - expanded, 4-11-12
  - extended, 2-2, 2-28, 4-11-12
  - LIM 4.0 EMS, 4-11
  - manager, 4-11-12
  - modules, see SIMMs
  - problems, A-4, A-27
  - specifications, D-1

MENU utility, Intro-3, 1-11

MGA card, see Video cards

MODE, 1-11

Modem, connecting, 1-11

Monitor,

- analog, 1-4,4-12
- connecting, 1-4-8
- interface, D-2
- multi-frequency, 1-4,4-12
- problems, A-13 -15
- selecting type, 1-4,1-7,2-6-8
- setting jumpers, 1-8,6-2-9

Monochrome display adapter and CRT check, C-9

Monochrome graphics adapter card, see Video cards

Mounting frames, hard disk, 7-8-9

Mounting plate, hard disk, 7-10-12

Mouse,

- connecting, 1-13-14
- interface, D-2
- port specifications, D-2
- problems, A-26

MS-DOS,

- copying files, 3-2, 3-21-23
- diskettes, 3-1-2
- installing, 3-1
- loading, 3-18-19

Multi-frequency monitor, Intro-3, 1-4, 4-12-13

## N

- Network server, 4-9 -11
- Network server mode, 2-9-11, 3-7, 4-9 -11
- Non-destructive surface analysis, B-2-3, B-12-13
- Non-interlaced mode, 4-12, A-1
- Num lock,
  - initial, 2-14-16
  - mode, 2-6, 2-14-16

## O

- Operating speed, see Processor speed
- Operation Menu, 2-3
- Option cards,
  - configuring, 6-23-24
  - installing, 6-1, 6-5-9
  - memory, 6-1
  - problems, A-25 -26
  - removing, 6-9-10
  - testing, 6-24, C-10 -11
  - video, see Video cards
- Option slots, 6-5-9, D-2
- Options, installing, 6-1-24
- OS/2 Intro-3

## P

- Parallel,
  - cable, 1-8-10
  - interface, 1-8 -10, 2-26 -28, D-2
  - port, 1-8-10
  - port check, C-10 -11
  - port on video adapter check, C-11
- Partitions on hard disk, 3-22, B-2, B-13
- Password, see Power-on password
- Physical characteristics, D-5

Physical formatting, B-1 -13

### Port,

- keyboard, 1-12-13, D-2
- monitor, 1-4-6, D-2
- mouse, 1-13-14, D-2
- parallel, 1-8-10, D-2
- serial, 1-11, D-2

### Power,

- button, 1-17
- cord, connecting, 1-2, 1-15-16
- source, 1-2
- supply, D-3

Power-on diagnostics, A-2 -5

### Power-on password,

- changing, 3-8-9
- deleting, 3-9, A-9 -11
- disabling, A-10 -11
- entering, 3-7 -9, 4-10 -11
- jumper, 6-3, A-9 -12
- network server mode, 2-9 -11, 3-7, 4-9 -11
- problems, A-8 -12
- setting, 2-9 -11, A-11 -12
- using, 3-7-9

### Power supply cables,

- see also Power cord
- 7-15 -16, 7-31-32

### Precautions,

- computer, 1-2, 1-16, 5-4
- diskette, 3-14 -15
- hard disk, 3-23

### Printer,

- connecting, 1-8 -11
- interface check, C-10
- parallel interface, 1-8 -10, D-2
- problems, A-24 -25
- serial interface, 1-11, D-2

Processor speed, 2-12 -14, 4-2-7, A-23, D-1

Protector card, 1-3, 1-16, 3-24

## R

RAM check, A-2  
Random access memory (RAM),  
Intro-1, 2-1,3-18, A-2  
Read only memory (ROM), Intro-1,  
A-2, D-1  
Read/write heads, 3-12, 3-23 -24  
Read/write slot, 3-15, 3-19  
Real-time clock, 2-16 -18, D-1  
Reassigning diskette drives, 4-7-9  
Redirecting printer output, 1-11  
Reference diskette, 2-1, 3-2, 6-23 -24  
Removing diskettes, 3-19 -20  
RESET button, 3-6 -9  
Resetting the computer, 3-5-6  
ROM, see Read Only Memory  
ROMBIOS.COM, 3-2, A-2

## S

Sector, 3-11  
SELECT, B-2  
Serial,  
cable, 1-11  
interface, 1-11,2-26 -28, D-2  
port, 1-11  
port check, C-10  
SETMODE, 1-11  
Setting up, 1-1-18  
Setup menu, 2-3,2-5  
Setup program, 2-1-31  
automatic configuration, 2-2  
caching, 2-11 -12  
clock, real&me, 2-1618  
cursor block, moving, 2-56  
diskette drive types, 2-25-26  
display adapter type, 2-6-8  
error message, continuing from,  
2-4-5  
hard disk drive configuration,  
2-19 -24

## Setup program,

keyboard options, 2-14 -16  
leaving the program, 2-30 -31  
math coprocessor, 2-2  
memory, 2-2, 2-11 -12, 2-28  
memory caching, 2-11 -12  
network server mode, 2-9 -11  
parallel interface, 2-26 -28  
power-on password, 2-9 -11  
processor speed, 2-12 -14  
real-time clock, 2-16 -18  
reviewing, 2-28 -30  
running, 2-1 -31,6-23 -24  
serial interface, 2-26 -28  
speaker option, 2-14 -16  
starting the program, 2-2-6  
summary, 2-28 -30

Shadow RAM, Intro- 1, D-1

## SIMMs,

installing, 6-1, 6-10 -15  
problems, A-27  
removing, 6-15-18  
specifications, 6-10 -11, D-1

Skewed sector, B-6

Slave drive, 7-4-6

Software problems, A-23

Speaker, 2-14-16, D-3

Special keys, 3-3 -4

Specifications, D-1 -5

Speed, see Processor speed

Subassembly,

removing, 5-5-8

replacing, 5-8 -15

Super VGA mode, Intro-1,  
4-12-13

System,

board check, C-9

diagnostics, C-1 -14

identifying, A-1 -2

memory, see Memory

setting up, 1-1 -18



## T

TIME, 2-16  
Time, setting, 2-16-18  
Timer check, A-2  
Tracks, 3-10 -13  
Troubleshooting, A-1 -28  
TURBO light, 4-2  
Turning off computer, 1-18  
Turning on computer, 1-16 -18

## U

Utilities,  
    CEG, 4-13  
    VGA, 4-12 -13

## V

VER, A-2  
VGA BIOS, 2-7-8  
VGA port,  
    connecting monitor, 1-44  
    setting jumper, 6-6 -10  
    setting type, 2-7 -9  
    specifications, D-2  
    utilities, see VGA utilities  
VGA utilities, Intro-3, 4-12-13  
VGAMODE, 4-13  
Video cards, see also Option cards  
    CGA, 1-7, 2-6-8  
    color graphics adapter and  
        CRT check, C-3, C-10  
    compatibility, 1-7  
    configuring, 2-6-8  
    EGA, 1-7, 2-6-8  
    features, 4-12 -13  
    Hercules graphics card, 1-7,  
        2-6 -8  
    installing, 1-7 -8  
    jumpers for, 6-3  
    MCGA, 2-6-8  
    MDA, 1-7, 2-6 -8  
    MGA, 1-7, 2-6 -8

Video cards,  
    monochrome display adapter  
        and CRT check, C-3, C-9  
    parallel port (on video adapter)  
        check, C-11  
    problems, A-13 -15, A-25 -26  
    setting display adapter type, 2-6-8  
    VGA, 1-7 -8, 2-6 -8  
Video graphics array (VGA),  
    built-in port, see VGA port  
    card, see Video cards  
Video monitors, see Monitor

## W

Write-protect notch, 3-16  
Write-protect switch, 3-17  
Write-protect tab, 3-16  
Write-protecting diskettes, 3-16 -17

## X

XCOPY, 3-14,3-21

EQUITY 386SX/20 PLUS

U s e r ' s G u i d e

**EPSON**

EQUITY 386SX/20 PLUS

U s e r ' s G u i d e

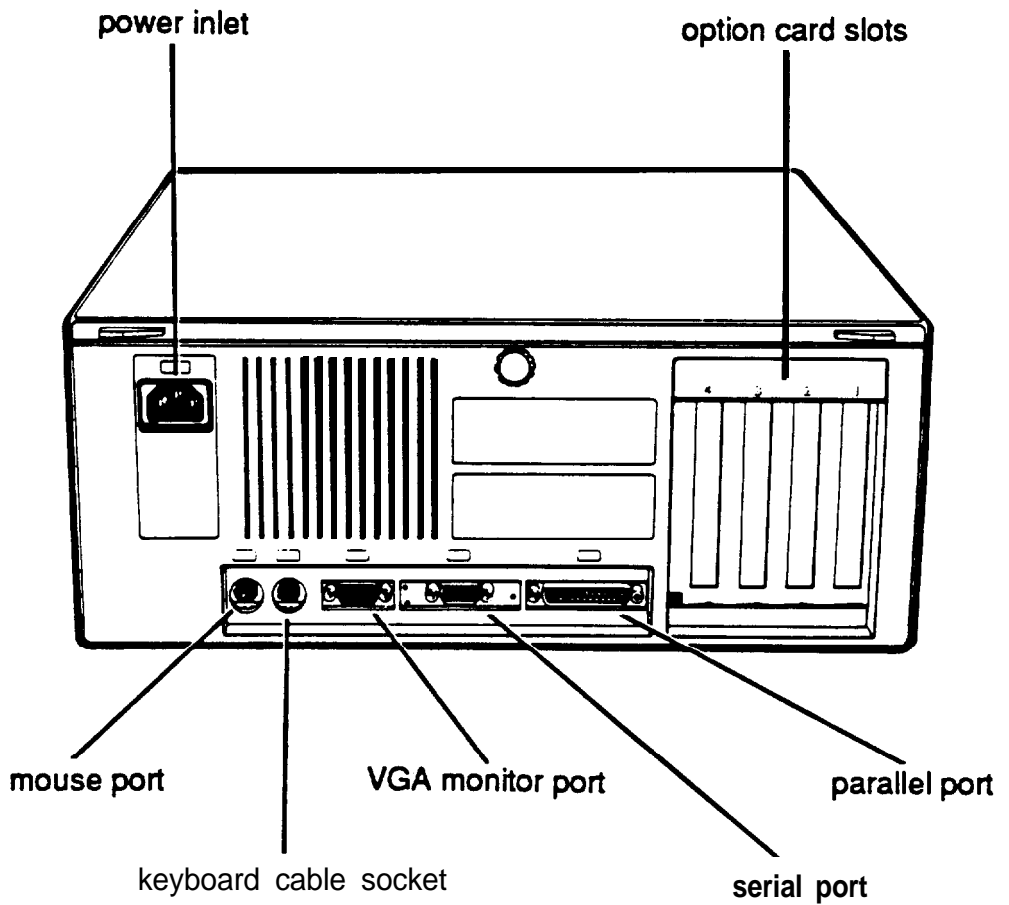
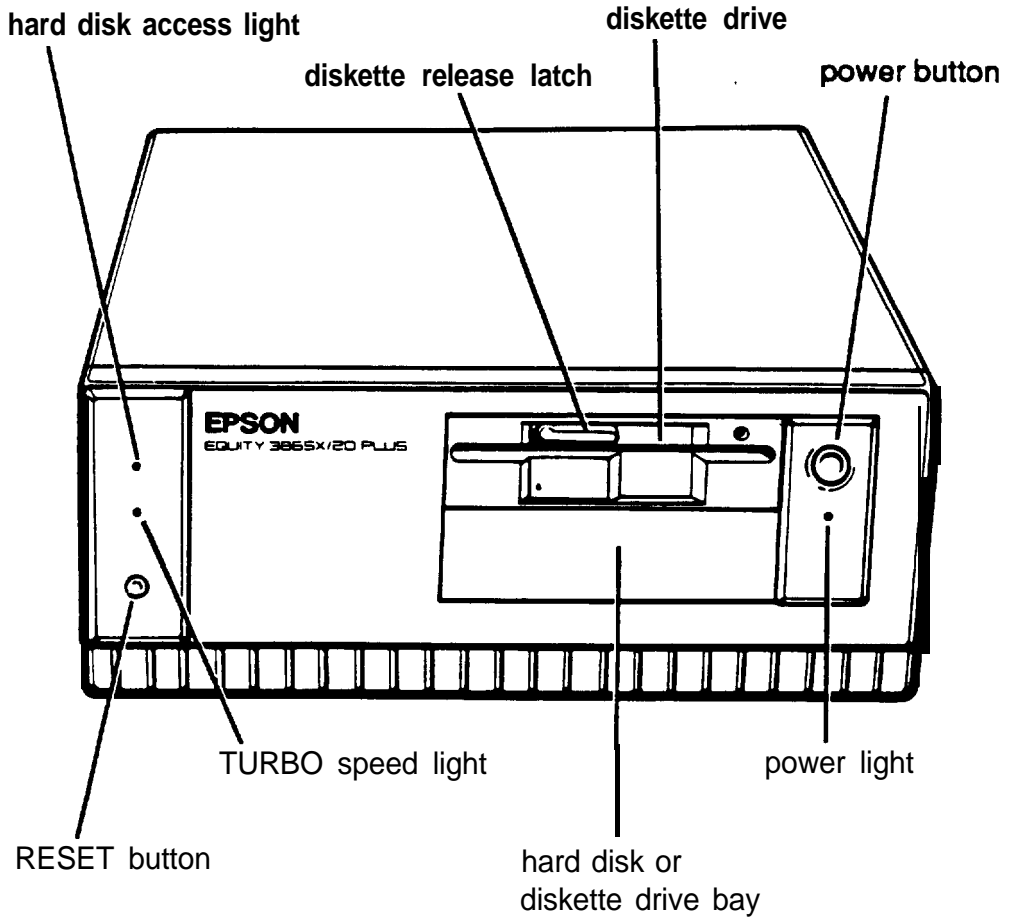

# EPSON Overseas Marketing Locations

---

**EPSON America, Inc.**

20770 Madrona Avenue  
Torrance, CA 90503, U.S.A.  
Phone: (213) 782-0770

---

**EPSON Deutschland GmbH**

Zülpicher Straße 6, 4000 Dusseldorf 11,  
F.R. Germany  
Phone: 211-56030  
Telex: 41-8584786

---

**EPSON France S.A.**

B.P. 320, 68 Bis Rue Marjolin  
92305 Levallois-Perret Cedex, France  
Phone: 33-1-4737-3333  
Telex: 42-610657

---

**EPSON Australia Pty. Ltd.**

17 Rodborough Road,  
Frenchs Forest, N.S.W. 2086, Australia  
Phone: 2-452-0666  
Telex: 71-75052

---

**EPSON Singapore PTE. LTD.**

No.1 Raffles Place #26-00,  
Oub Centre, Singapore 0104  
Phone: 533-0477  
Telex: 87-39536

---

**EPSON Hong Kong Ltd.**

25/F., Harbour Centre,  
25 Harbour Road,  
Wanchai, Hong Kong  
Phone: 5-831-4600  
Telex: 802-65542

---

**EPSON Electronics Trading Ltd.****Taiwan Branch**

10F, NO. 287, Nanking E. Road,  
Sec. 3, Taipei, Taiwan  
Phone: 886-2-7 17-7360  
Telex: 785-24444

---

**EPSON IBERICA, S.A.**

C/Paris 152, 08036 Barcelona,  
Spain  
Phone: 3-410-3400  
Telex: 52-50129

---

**EPSON Italia S.p.A.**

V.le F.lli Casiraghi, 427  
20099 Sesto S. Giovanni MI, Italy  
Phone: 2-26233.1

---

**SEIKO EPSON Corporation**

(Hirooka Office)  
80 Harashinden, Hirooka  
Shiojiri-shi, Nagano-ken  
399-07 Japan  
Phone: (0263) 52-2552  
Telex: 3342-214 (SEPSON J)

---

**EPSON UK Ltd.**

Campus 100  
Maylands Avenue  
Hemel Hempstead, Hertfordshire, HP2 7EZ, U.K.  
Phone: (LINKLINE) 0800 289622  
Telex: 51-82467

## **Epson America, Inc.**

---

20770 Madrona Avenue, Torrance, CA 90503