

Epson Stylus® CX5000 Series



Quick Guide

*Basic Copying, Printing, and Scanning
Maintaining Your Epson Stylus CX5000 Series All-in-One
Solving Problems*

Contents

Loading Paper	5
Copying a Photo or Document	7
Placing the Original on the Glass	7
Copying	9
Printing From a Memory Card	12
Compatible Cards and Image Formats	13
Inserting the Card	14
Printing an Index Sheet to Select Photos	15
Printing All Photos or DPOF Photos	17
Printing From a Digital Camera	18
Printing From Your Computer	20
Printing in Windows	20
Printing with a Macintosh	23
Using Special Papers	26
Scanning a Photo or Document	29
Basic Scanning	29
Restoring Color in Faded Photos	31
Maintaining Your CX5000 Series All-in-One	32
Checking the Print Head Nozzles	32
Cleaning the Print Head	33
Checking the Ink Cartridge Status	34
Replacing Ink Cartridges	34

Solving Problems	40
Error Indicators	40
Problems and Solutions	42
Where To Get Help	44
Notices	46

Introduction

After you have set up your Epson Stylus® CX5000 Series all-in-one as described on the *Start Here* sheet, turn here to:

- Load paper
- Make a quick copy of a document or photo
- Print photos stored on a memory card
- Print photos directly from your camera
- Get the basic steps for printing from your computer
- Scan a document or photo, including restoring a color photo as you scan
- Perform routine maintenance
- Solve simple problems

This book tells you how to do most of these things without ever turning on your computer! Of course your CX5000 Series can do a lot more when you connect it to your Windows® or Macintosh® computer. For additional instructions, see the on-screen *User's Guide* by selecting the icon for it on your desktop.

Please follow these guidelines as you read your CX5000 Series instructions:

Warning:

Warnings must be followed carefully to avoid bodily injury.

Caution:

Cautions must be observed to avoid damage to your equipment.

Note:

Notes contain important information about your CX5000 Series.

Tip:

Tips contain hints for better copying, scanning, and printing.

Loading Paper

Follow the steps here to load paper in your Epson Stylus CX5000 Series all-in-one.

1. Open the paper support and slide out the extensions.

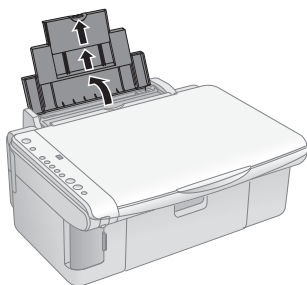

2. Open the output tray and pull out the extension.

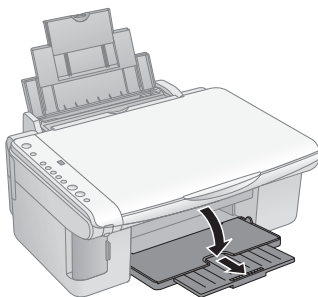

3. Flip the feeder guard forward.

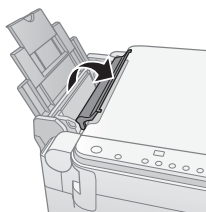

4. Insert the paper, printable side up, against the right edge guide and beneath the tabs. (The printed side is whiter or brighter on some papers.) Always load paper short edge first, even for landscape printing.

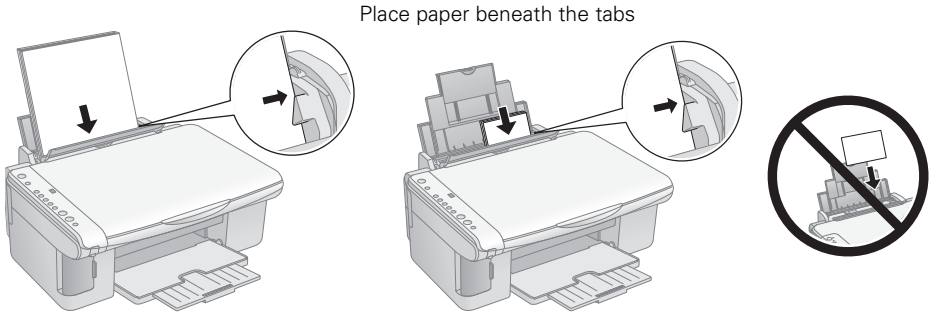

You can load up to 100 sheets of plain paper and up to 20 sheets of photo or matte paper (see the *User's Guide* for capacity guidelines on other paper types).

Note:

The type of paper you choose affects the way your printout looks, so be sure to select the correct paper for your job. If you are just making a copy or printing a rough draft of an image, plain paper is fine. However, for the best results, you'll want to use one of Epson's special ink jet papers designed for your printer. For example, your photos will look great printed on Epson Premium Photo Paper Glossy (see page 26 for more information).

5. Slide the left edge guide against the left edge of the paper (but not too tightly).

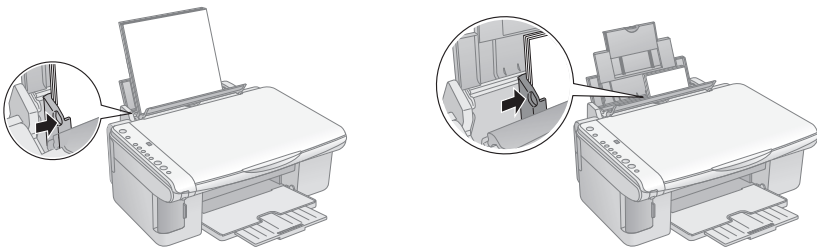

6. Flip the feeder guard back.

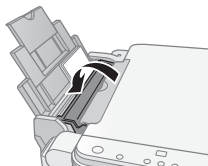

Copying a Photo or Document

Follow the instructions in this section to:

- Position your photo or document correctly on the glass (see below)
- Make copies of a photo or document (see page 9)

Placing the Original on the Glass

1. Open the document cover and place your original face-down on the glass, in the upper left corner.

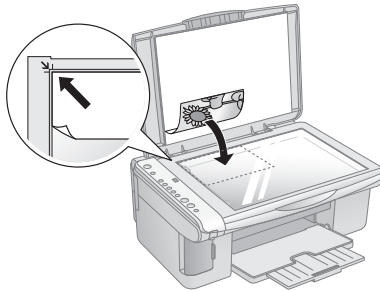

2. Close the cover gently so you don't move the original.

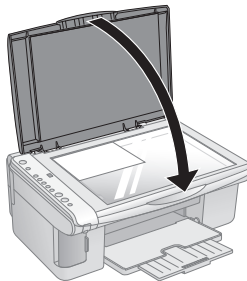

Caution:

Never open the document cover beyond where it stops and do not place heavy objects on top of the Epson Stylus CX5000 Series all-in-one.

If you need to copy or scan a thick or large document, you can remove the document cover. Just open it and pull it straight up.

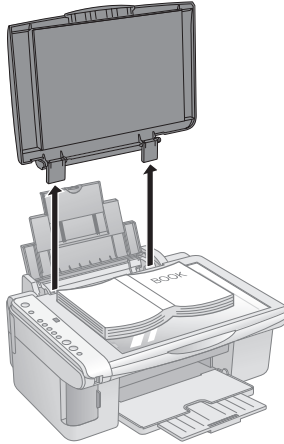

If you need to press the document flat while you copy or scan it, do not press too hard and be careful not to move it.

Note:

Do not use excessive force on the document cover, and do not twist it. You may damage the document cover.

When you are done, replace the document cover by inserting the tabs back into the slots.

Copying

You can make copies using letter-size (8.5 × 11-inch), 4 × 6-inch, and 5 × 7-inch plain, photo, or matte paper.

Copying a Document

1. Make sure the Epson Stylus CX5000 Series all-in-one is turned on.
2. Place the document on the glass as described on page 7. Be sure to close the document cover.
3. Load up to 100 sheets of letter-size plain paper (see page 5 if you need instructions).
4. Press the **Copies** button until you see the desired number of copies in the **Copies** window. You can select up to 9 copies at a time this way.



To make more than 9 copies, see page 11.

5. Press the paper type button to select **Plain Paper**. The light indicates which type is selected.
6. Press the paper size button to select **Letter**.
7. If you want your copies automatically reduced or enlarged to fit the selected paper size, press the **Fit to Page** button.
8. To make a color copy, press the **Start Color** button.

To make a black and white copy, press the **Start B&W** button.

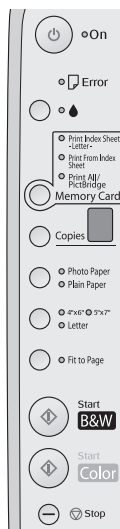

The **On** light flashes and after a moment the CX5000 Series starts printing.

If you need to stop copying, press the **Stop** button. Do not pull out paper that is being printed; it will be ejected automatically to the output tray.

Note:

The copies may not be exactly the same size as the original.

Copying a Photo



1. Make sure the Epson Stylus CX5000 Series all-in-one is turned on.
2. Place the photo on the glass as described on page 7. Be sure to close the document cover.
3. Load up to 20 sheets of letter-size, 4 × 6-inch, or 5 × 7-inch photo or matte paper (see page 5 if you need instructions).
4. Press the **Copies** button until you see the correct number of copies in the **Copies** window. You can select up to 9 copies at a time this way.

To make more than 9 copies, see page 11.

5. Press the paper type button to select **Photo Paper**.
6. Press the paper size button to select **Letter, 4"×6"**, or **5"×7"**.
7. If you want borderless photos (printed without a white border), press the **Fit to Page** button. Otherwise, photos are printed with a small white border.
8. To make a color copy, press the **Start Color** button.

To make a black and white copy, press the **Start B&W** button.

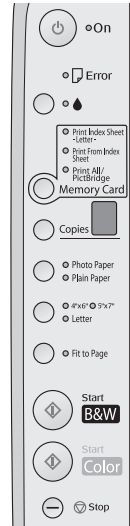

The **On** light flashes and after a moment the CX5000 Series starts printing.

If you need to stop copying at any time, just press the **Stop** button. Do not pull out paper that is being printed; it will be ejected automatically to the output tray.

Note:

The copies may not be exactly the same size as the original.

Making 10 or More Copies

1. Make sure the Epson Stylus CX5000 Series all-in-one is turned on.
2. Place the photo on the glass as described on page 7. Be sure to close the document cover.
3. Press the **Copies** button until you see “–” in the **Copies** window. This tells the CX5000 Series to print up to 100 copies.
4. Load enough paper for the number of copies (up to 100) you want to make. For example, to print 12 copies, load 12 sheets of paper.
5. Press the paper type button to select **Plain Paper** or **Photo Paper**.
6. Press the paper size button to select **Letter, 4"x6",** or **5"x7"**.
7. Press the **Start Color** or **Start B&W** button.

The CX5000 Series makes copies until it runs out of paper. Then the red **Error** light comes on.

8. To make more copies, load more paper and press the **Start Color** button to resume.

If you don't need any more copies, press the **Stop** button.

Note:

When making a lot of copies, it is a good idea to remove the printed copies from the output tray after every 10 sheets or so.

Making a Quick Copy

If you want to make a copy quickly and do not need high quality, you can print a “draft” copy. The print quality is reduced, but the copy is printed faster.

1. Load plain, letter-size paper and select **Plain Paper** and **Letter** size on the control panel.
2. When you are ready to copy, press and hold down the **Stop** button, then press the **Start Color** button (to copy in color) or the **Start B&W** button (to copy in black and white). When the **On** light starts flashing, release both buttons.

Printing From a Memory Card

The Epson Stylus CX5000 Series all-in-one lets you print color photos directly from your digital camera's memory card; just insert it into a memory card slot on the CX5000 Series and you're ready to print.

If your digital camera supports DPOF (Digital Print Order Format), you can pre-select the photos you want to print while the card is still in the camera. Then, when you insert the card in the CX5000 Series, it knows which photos to print and how many copies of each.

See these sections:

- “Compatible Cards and Image Formats” (see below)
- “Inserting the Card” on page 14
- “Printing an Index Sheet to Select Photos” on page 15
- “Printing All Photos or DPOF Photos” on page 17

For instructions on copying memory card files between your CX5000 Series and a computer or other device, see the *User's Guide*.

Compatible Cards and Image Formats

You can use the following types of cards with your Epson Stylus CX5000 Series all-in-one:

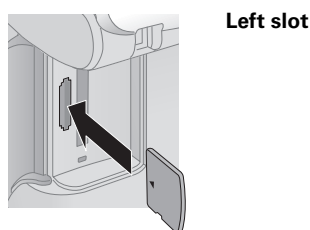
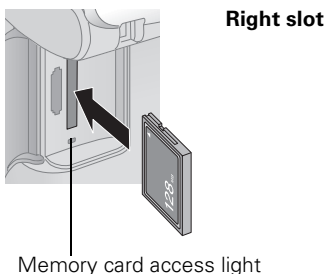

Slot	Type of card
Right slot	CompactFlash™ Microdrive™
Left slot	SD™ SDHC miniSD™* miniSDHC* microSD* microSDHC* MultiMediaCard Memory Stick™ Memory Stick Duo™* Memory Stick PRO™ Memory Stick Pro Duo™* MagicGate™ Memory Stick MagicGate Memory Stick Duo* xD-Picture Card xD-Picture Card Type H xD-Picture Card Type M

* Adapter required

The CX5000 Series supports image files that meet the following requirements:

Media format	DCF version 1.0 or 2.0 compliant*
File format	JPEG Supports Exif version 2.21
Image size	80 × 80 pixels to 9200 × 9200 pixels
Number of files	Up to 999

* DCF is the “Design rule for Camera File system” standard

Note:

You can print only in color when printing directly from a memory card; you cannot print in black and white.

Inserting the Card

1. Make sure the Epson Stylus CX5000 Series all-in-one is turned on.

Note:

When you print directly from a memory card, it is best if the CX5000 Series is not connected to your computer (or your computer should be turned off). If you see a message on your computer screen when you insert a card in the CX5000 Series, just cancel the operation and close the screen.

2. Open the memory card door.

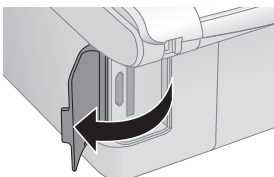

3. Make sure the memory card access light is off and that no cards are in any of the slots. Then insert your card into the correct slot (see page 13 for details). The memory card access light flashes and then stays on.

Insert just one card at a time (it won't go in all the way)

Left slot

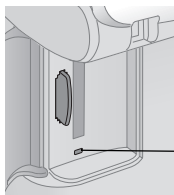

Right slot

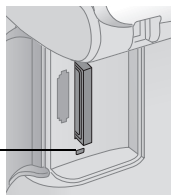

Memory card
access light

4. Close the memory card door. Now you can:
 - Print an index sheet so you can select which photos to print (see page 15)
 - Print all the photos on the card (see page 17)
 - Print photos pre-selected on your camera using DPOF (see page 17)

When you want to remove the card, make sure the memory card access light is not flashing, then pull the card straight out of its slot.

Caution:

Do not remove the card or turn off the CX5000 Series while the memory card access light is flashing; you may lose data on the card.

Printing an Index Sheet to Select Photos

You can print an index sheet (which is like a photographer's contact or proof sheet) to see small "thumbnail" images of all the pictures on your card. Then you can mark the pictures on the index sheet that you want to print, scan the sheet, and let the Epson Stylus CX5000 Series all-in-one automatically print the selected photos.

Printing the Index Sheet

1. Make sure your CX5000 Series is not connected to your computer (or your computer is turned off).
2. Load several sheets of letter-size, plain paper. (Use only letter-size paper to print the index sheet.) Up to 30 images are printed on each page, so if there are more than 30 photos on the memory card, you'll need enough sheets for all the index pages to be printed.
3. Insert the memory card if it is not already in the slot (see page 14).
4. Press the **Memory Card** button one or more times until the **Print Index Sheet** light comes on.
5. Make sure **Plain Paper** and **Letter** are selected.
6. Press the **Start Color** button. The **On** light flashes, and the CX5000 Series starts printing the index sheets. (This may take a few minutes.)

For multiple index sheets, the pages containing the most recent images are printed first. If you want to cancel printing more sheets, press the **Stop** button.

Note:

Make sure the triangle mark on the upper left corner of the index sheet is printed completely so the CX5000 Series can scan it correctly.

Now follow the instructions in the next section to select which photos to print.

Selecting Photos on the Index Sheet

1. Once you have printed the index sheet, use a dark pen or pencil to fill in one of the circles beneath each photo you want to print to indicate how many copies you want (1, 2, or 3).

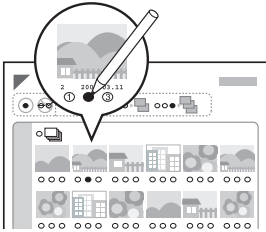

OK: 

No good:   

Make sure just one circle is filled in for each selected photo and mark the sheet carefully; once it has been scanned you will not be able to change your selections.

Note:

If you want one copy of all the photos on the index sheet, fill in the **ALL** circle at the top of the page.

2. Place the index sheet face-down on the glass, in the upper left corner, so that the top of the sheet is aligned against the left edge of the glass.

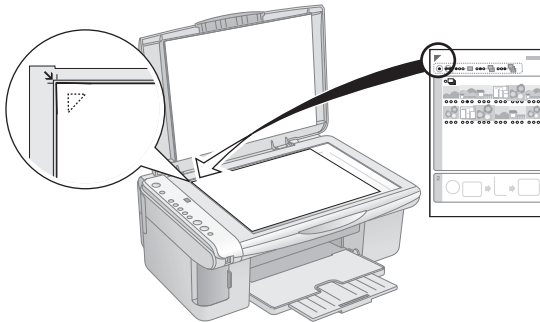

3. Close the document cover.
4. Load up to 100 sheets of plain paper or up to 20 sheets of photo or matte paper at a time (see page 5 for details). You can load more paper later as necessary to print all your selected photos.
5. Make sure the Print From Index Sheet light is on.

6. Select **Plain Paper** or **Photo Paper** (whichever you loaded). If you select **Plain Paper**, your photos print with a white border. If you select **Photo Paper**, your photos print borderless, to the edge of the paper.
7. Select **Letter**, **4"x6"**, or **5"x7"** for the paper size.
8. Press the **Start Color** button to start printing.

Note:

If you need to stop printing, press the **Stop** button.

Printing All Photos or DPOF Photos

Follow the steps below to print one copy of each photo on the card or to print only those photos that were pre-selected with your camera's DPOF (Digital Print Order Format) feature.

1. Make sure your Epson Stylus CX5000 Series all-in-one is not connected to your computer (or your computer is turned off).
2. Load up to 100 sheets of plain paper or up to 20 sheets of photo or matte paper at a time (see page 5). You can load more paper later as necessary to print all your photos.
3. Insert the memory card (see page 14).
4. Press the **Memory Card** button until the **Print All/PictBridge** light comes on.

Note:

If the memory card does not contain DPOF information, one copy of all the photos on the card will be printed.

5. Select **Plain Paper** or **Photo Paper** (whichever you loaded). If you select **Plain Paper**, the photos print with a white border. If you select **Photo Paper**, the photos print borderless, to the edge of the paper.
6. Select **Letter**, **4"x6"**, or **5"x7"** for the paper size.
7. Press the **Start Color** button to start printing.

Note:

If you need to stop printing, press the **Stop** button.

Printing From a Digital Camera

If your camera is PictBridge- or USB DIRECT-PRINT™-compatible, you can print your JPEG photos by connecting your digital camera directly to your Epson Stylus CX5000 Series all-in-one. Your photos must be sized from 80 × 80 pixels to 9200 × 9200 pixels.

1. Make sure your CX5000 Series is not printing.
2. Remove any memory cards from the slots.
3. Press the **Memory Card** button until the **Print All/PictBridge** light comes on.
4. Load the type of paper you want to use (see page 5). Load enough sheets for the number of photos you'll be printing.
5. Press the paper type button to select **Photo Paper** to print borderless photos (without a white border). Select **Plain Paper** if you want your photos printed with a small white border.
6. Press the paper size button to select **Letter**, 4"x6", or 5"x7".
7. Connect the USB cable that came with your camera to the camera and to the  USB connector on the front of your CX5000 Series.

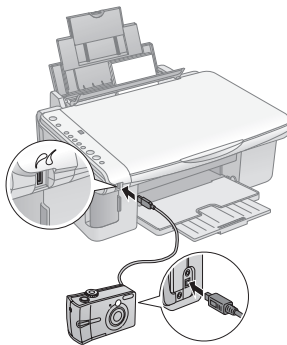

8. Make sure your camera is turned on.

9. Select the photos you want to print with your camera. Then adjust any necessary settings and print your photo as explained in your camera manual.

Note:

If your camera is not supported, a flashing **P** appears in the Copies window, and the **□** Error light and **Print All/PictBridge** lights flash. Epson cannot guarantee the compatibility of any camera.

Depending on the CX5000 Series settings and your digital camera settings, some combinations of paper type, size, and layout may not be supported. In addition, some of your digital camera settings may not be reflected in the printed output.

Printing From Your Computer

This section describes the basic steps for printing a photo or document stored on your Windows or Macintosh computer.

Note:

For detailed instructions on printing, see the on-screen *User's Guide*.

Before you start, make sure you've installed your printer software and connected the Epson Stylus CX5000 Series all-in-one to your computer as described on the *Start Here* sheet. Also be sure to use the right paper and select the correct paper type setting in the printer driver (see page 26 for more information).

Tip:

Periodically, it's a good idea to check Epson's support website at epson.com/support for free updates to your Epson Stylus CX5000 Series printer and scanner software. Download instructions are posted for your convenience. With Windows, you can also click **Start** or , select **Programs** or **All Programs**, select **EPSON**, and click **Epson Stylus CX5000 Series Driver Update** for driver updates.

Follow the instructions in these sections:

- “Printing in Windows” (below)
- “Printing with a Macintosh” on page 23
- “Using Special Papers” on page 26

Printing in Windows

1. Load paper (see page 5).
2. Open a photo or document in a printing program.

3. Open the File menu and select **Print**. You see a window like this one:

Select EPSON Stylus CX5000 Series

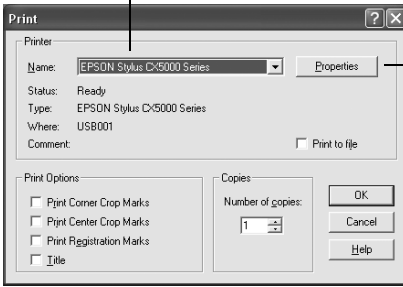

Click here to open your printer software

4. Make sure **Epson Stylus CX5000 Series** is selected, then click the **Preferences** or **Properties** button.

(If you see a **Setup**, **Printer**, or **Options** button, click it. Then click **Preferences** or **Properties** on the next screen.)

5. On the **Main** tab, select the basic print settings:

Select the type of document you're printing
(choose **Photo** or **Best Photo** for pictures)



Select your paper **Type**

Select your paper **Size**

Click here for borderless photos

Select your document **Orientation**

Click here for more options

Make sure you choose the correct paper **Type** setting for the paper you are using (see page 26 for details).

Note:

For more information about print settings, click the ? or **Help** button.

6. For more printing options, click the **Advanced** button. Then select the following settings as necessary:

Select a color management method
(To choose **No Color Adjustment**, click **ICM** first)

Select **Paper & Quality Options** as necessary

Select **Print Options** as necessary

Click here if you want to see this Advanced screen each time you access your print settings

Note:

For more information about advanced settings, or instructions on saving them as a group so you can reuse them later, click ? or **Help**.

7. If you want to change the layout settings, click the **Page Layout** tab and select settings as necessary.

- Click **OK** to save your settings, then click **OK** or **Print** to start printing. This window appears and shows the progress of your print job.

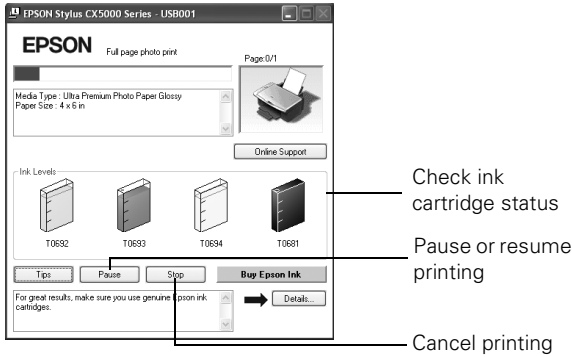

Printing with a Macintosh

Follow the steps below to print with a Macintosh:

- Load paper (see page 5).
- Open the photo or document in your application.
- Select **Page Setup** from the File menu. Make the following settings:

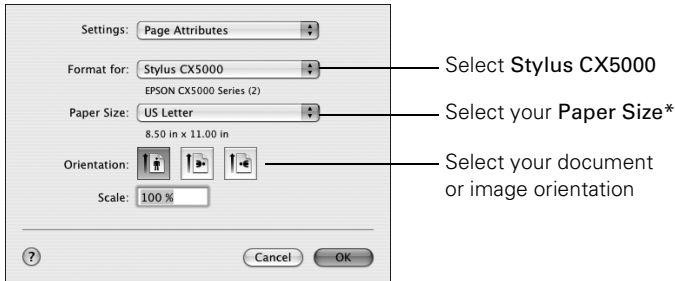

* For borderless printing, choose a **Sheet Feeder - Borderless** option in the Paper Size list for your paper size (US Letter, 8 x10 in, 4 x6 in, or 5 x7 in).

- Click **OK** to close the Page Setup window.

5. Select **Print** from the File menu. You see a window like this one:

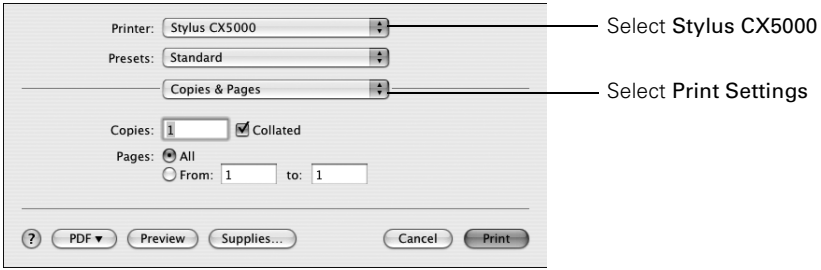

6. Choose **Print Settings** from the pop-up menu and select the following settings as necessary:

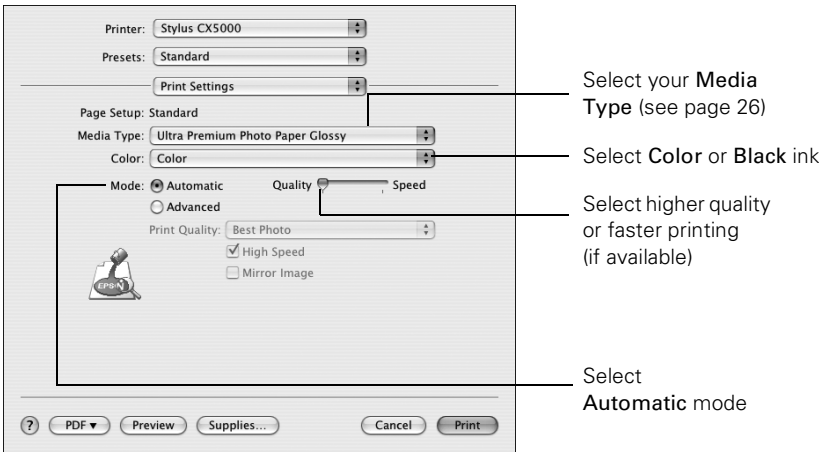

Note:

In certain programs, you may need to select **Advanced** before you can select **Print Settings**. For more information about printer settings, click the ? button.

7. Depending on your settings, you can choose other options from the pop-up menu, including:
- **Copies & Pages:** Select the number of copies you want, or a page range.
 - **Layout:** Select page layout options.
 - **Scheduler:** Schedule your print job to print at a later time.
 - **Paper Handling:** Select page printing options, such as **Reverse print order**.

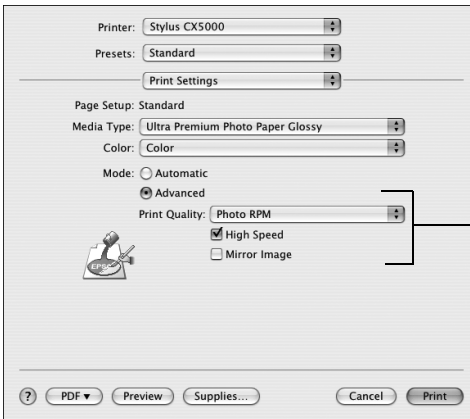

- **ColorSync or Color Management:** Select ColorSync® or adjust the color controls, change the gamma setting, or turn off color adjustments in the printer software.
 - **Cover Page (OS X 10.4.x only):** Add a cover page before or after the document.
 - **Expansion:** Reduce or enlarge the image size for borderless printing.
 - **Summary:** View a list of all your selections.
8. Click the **Advanced** button to change additional settings.



Select Print Quality and other options as necessary

Note:

For more information on advanced settings, or instructions on saving them as a group so you can reuse them later, click ?.

9. Click **Print**.
10. To monitor the progress of your print job, click the  printer icon when it appears in the dock on the bottom of your desktop.
- If you're using OS X 10.2.x, click the  Print Center icon instead, then double-click **CX5000 Series** in the Printer List window.

You see a screen like this:



11. When you're finished, close the printer window or Print Center.

Using Special Papers

Epson offers a wide array of high quality papers, making it easy to maximize the impact of your photos, presentations, and creative projects.

Paper category	Description
Photo Papers	For lab quality photos—from everyday snapshots to professional portraits. Available in glossy, semi-gloss, and luster finishes.
Matte Papers	Non-glare paper with a smooth or textured finish for professional quality photos, brochures, or art projects.
Scrapbooking Papers	Acid-free, lignin-free paper for archival quality photos, backgrounds, headlines, and other page elements.
Fine Art Papers	Luxurious weight, texture, and finish give these fine art papers a true museum quality appearance.
Specialty Papers	For projects that showcase your favorite photos, including greeting cards, iron-on transfers, and transparencies.

You can purchase genuine Epson ink and paper from an Epson authorized reseller. To find the nearest reseller, call 800-GO-EPSON (800-463-7766). Or you can purchase online at www.epsonstore.com (U.S. sales) or www.epson.ca (Canadian sales).

Paper name	Size	Part number
Epson Ultra Premium Photo Paper Glossy Epson Ultra Premium Glossy Photo Paper	Borderless 4 × 6 inches	S041934
	Letter (8.5 × 11 inches)	S041935
Epson Premium Photo Paper Glossy Epson Premium Glossy Photo Paper	Borderless 4 × 6 inches	S041808/S041727
	Borderless 5 × 7 inches	S041464
	Borderless 8 × 10 inches	S041465
	Letter (8.5 × 11 inches)	S041286/S041667
Epson Premium Photo Paper Semi-gloss Epson Premium Semigloss Photo Paper	Letter (8.5 × 11 inches)	S041331
Epson Photo Paper Glossy Epson Glossy Photo Paper	Borderless 4 × 6 inches	S041809
	Letter (8.5 × 11 inches)	S041141/S041649/ S041272/S041271
Epson Bright White Paper Epson Premium Bright White Paper	Letter (8.5 × 11 inches)	S041586
Epson Premium Presentation Paper Matte Epson Matte Paper Heavyweight	Borderless 8 × 10 inches	S041467
	Letter (8.5 × 11 inches)	S041257
Epson Premium Presentation Paper Matte Double-Sided Epson Double-Sided Matte Paper	Letter (8.5 × 11 inches)	S041568
Epson Presentation Paper Matte Epson Photo Quality Ink Jet Paper	Letter (8.5 × 11 inches)	S041062
	Legal (8.5 × 14 inches)	S041067
Epson Photo Quality Self-Adhesive Sheets	A4 (8.3 × 11.7 inches)	S041106
Epson Iron-On Cool Peel Transfer Paper Epson Iron-On Transfer Paper	Letter (8.5 × 11 inches)	S041153
PremierArt Matte Scrapbook Paper for Epson	Letter (8.5 × 11 inches)	SCR1002

Select the correct **Type** (see page 21) or **Media Type** (see page 24) setting in your printer software:

For this paper	Select this setting
Plain paper Epson Bright White Paper Epson Premium Bright White Paper	Plain Paper/Bright White Paper
Epson Ultra Premium Photo Paper Glossy Epson Ultra Premium Glossy Photo Paper	Ultra Premium Photo Paper Glossy
Epson Premium Photo Paper Glossy Epson Premium Glossy Photo Paper	Premium Photo Paper Glossy
Epson Photo Paper Glossy Epson Glossy Photo Paper	Photo Paper Glossy
Epson Premium Photo Paper Semi-gloss Epson Premium Semigloss Photo Paper	Premium Photo Paper Semi-Gloss
Epson Premium Presentation Paper Matte Epson Premium Presentation Paper Matte Double-Sided Epson Presentation Paper Matte Epson Matte Paper Heavyweight Epson Photo Quality Ink Jet Paper Epson Photo Quality Self-Adhesive Sheets Epson Iron-On Cool Peel Transfer Paper Epson Iron-On Transfer Paper PremierArt Matte Scrapbook Paper for Epson	Premium Presentation Paper Matte
Envelopes	Envelope

Scanning a Photo or Document

You can use your Epson Stylus CX5000 Series all-in-one to scan a photo or document and save it on your computer or other device, or to fax or e-mail it to someone else.

You can even automatically restore faded color photographs as you scan (see page 31 for details).

The Epson Scan software provides three scanning modes for progressive levels of control over your scanned image:

- **Full Auto Mode** scans quickly and easily using automatic settings.
- **Home Mode** previews your image and provides automatic image adjustments, cropping tools, and preset options for various types of scans.
- **Professional Mode** previews your image and lets you manually configure your scan settings with a full array of tools.

Basic Scanning

You can scan from any TWAIN-compliant application—such as ArcSoft PhotoImpression™—using Epson Scan. Or you can start Epson Scan directly from your computer and save your image to a file.

1. Open the document cover and place your original face-down on the glass, in the upper left corner.

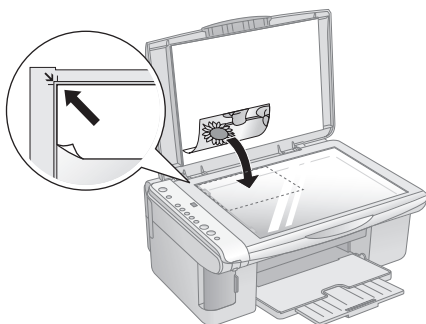

Note:

If you need to scan a thick document, you can remove the document cover (see page 8).

2. Close the cover gently so you don't move the original.
3. Do one of the following to start Epson Scan:
 - **Windows:** Double-click the EPSON Scan icon on your desktop.
 - **Macintosh:** Double-click EPSON Scan in the Applications folder.
 - If you are scanning from an application, start your application. Then open the File menu, choose **Import** or **Acquire**, and select **Epson Stylus CX5000 Series**.

You see the Epson Scan standby window:

4. If the Mode setting in the upper right corner is set to **Full Auto Mode**, click the **Scan** button.

Note:

If you want to automatically restore a color photo as you scan, click the **Customize** button (see page 31 for instructions).

If you are in Home or Professional Mode, you see a different Epson Scan settings window. (You can change the mode using the Mode selector in the upper right corner. For details, see the on-screen *User's Guide*.)

5. You see the File Save Settings window:

Choose the location where you want to save your scanned file and type a name for it in the Prefix box. Select a file format in the Image Format box.

6. Click **OK**. The image is scanned and you see its icon in an open folder.

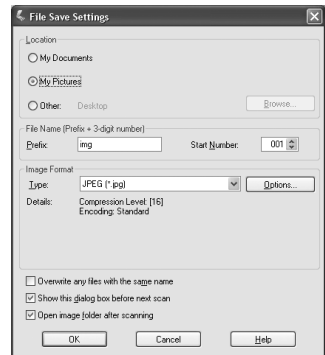
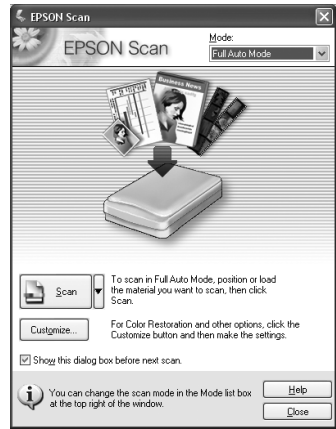

Restoring Color in Faded Photos

You can automatically transform an old, faded, or badly exposed color photo into one with true-to-life color and sharpness as you scan. Look for the **Color Restoration** option in Epson Scan's Full Auto, Home, and Professional Mode screens:

Full Auto Mode

Click the **Customize** button, click the **Color Restoration** button, click **OK**, and click **Scan**.

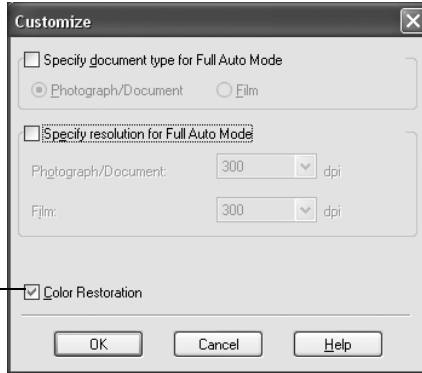

Home Mode

Click the **Color Restoration** button, preview your image, and click **Scan**.

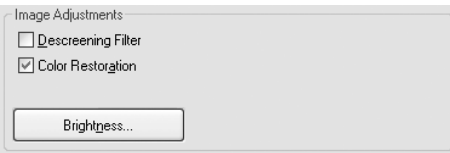

Professional Mode

Scroll down to the Adjustments area, click the **Color Restoration** button, preview your image, and click **Scan**.

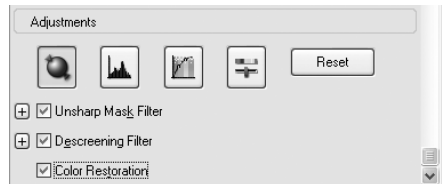

Note:

For details on using Home or Professional Mode, or for more information about Full Auto Mode settings, see the on-screen *User's Guide*. You can also click **Help** on the Epson Scan screen for information about all the available settings.



Maintaining Your CX5000 Series All-in-One

If you notice a decline in print quality, follow the instructions in this chapter for:

- “Checking the Print Head Nozzles” (see below)
- “Cleaning the Print Head” on page 33
- “Checking the Ink Cartridge Status” on page 34
- “Replacing Ink Cartridges” on page 35

Checking the Print Head Nozzles

If your printouts are faint or have gaps in them, some of the nozzles in the print head may be clogged or ink may be running low in one or more of the ink cartridges. Follow the steps below to check the print head nozzles using the control panel.

1. Turn off the Epson Stylus CX5000 Series all-in-one.
2. Load letter-size paper in the sheet feeder.
3. Press the  ink and  On buttons together and hold them down for about 3 seconds. The CX5000 Series turns on and prints a test pattern.

**Print head
nozzles are clean:**

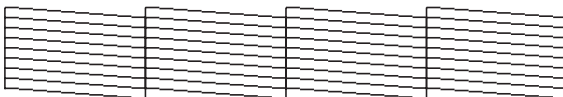

**Print head needs
to be cleaned:**



If the pattern does not look good, try cleaning the print head as described on the next page.



Cleaning the Print Head

If your printouts are unexpectedly light or faint, or you notice light or dark bands across your printout, you may need to clean the print head. This unclogs the nozzles so they can deliver ink properly. Run a nozzle check as described on page 32 to see if the print head needs cleaning.

Note:

Print head cleaning uses ink, so clean it only if quality declines and the nozzle check indicates that the print head needs to be cleaned.

If the red  ink light comes on or flashes, you cannot clean the print head. In this case, replace the appropriate ink cartridge first (see page 35).

1. Make sure the Epson Stylus CX5000 Series all-in-one is on and the  ink light is off.
2. Hold down the  ink button for 3 seconds until the **On** light starts flashing. The CX5000 Series runs a head cleaning cycle and the **On** light flashes.

Caution:

Never turn off the CX5000 Series while head cleaning is in progress. You may damage it.

3. When the **On** light stops flashing, run a nozzle check (as described on page 32) to verify that the print head is clean.
4. If there are still gaps or lines, or the test patterns are faint, run another cleaning cycle and check the nozzles again.



Note:

If you don't see any improvement after cleaning the print head four times, turn off the CX5000 Series and wait at least six hours. This lets any dried ink soften. Then try cleaning the print head again. If quality still does not improve, one of the ink cartridges may be old or damaged and needs to be replaced (see page 35).

Tip:

If you do not use your CX5000 Series often, it is a good idea to print a few pages at least once a month to maintain good print quality.

Checking the Ink Cartridge Status

When the red  ink light starts flashing, one or more cartridges are low on ink. When the red  ink light stays on, you need to replace the cartridge(s). You'll also see a message on your screen when you print, telling you which cartridge is low or expended. (You cannot print when a cartridge is expended.)

Tip:

If a cartridge is more than six months old, print quality may decline. If necessary, try cleaning the print head (see page 33). If printouts still do not look their best, you may need to replace the cartridge.

You can purchase genuine Epson ink and paper from an Epson authorized reseller. To find the nearest reseller, call 800-GO-EPSON (800-463-7766). Or you can purchase online at www.epsonstore.com (U.S. sales) or www.epson.ca (Canadian sales).

Use these part numbers when you order or purchase new ink cartridges:

Color	Part number	T code number
Black	69	T069120
	68 (High-Capacity)	T068120 (High-Capacity)
Cyan	69	T069220
Magenta	69	T069320
Yellow	69	T069420

Caution:

Leave the expended cartridge installed until you have obtained a replacement, or the ink remaining in the print head nozzles may dry out.

Replacing Ink Cartridges

Make sure you have a new ink cartridge before you begin. Once you start replacing a cartridge, you must complete all the steps in one session.



Caution:

Do not open ink cartridge packages until you are ready to install the ink. Cartridges are vacuum packed to maintain reliability.

1. Make sure the Epson Stylus CX5000 Series all-in-one is on.
2. Make sure that the document cover is closed, then open the scanner.

Caution:

Do not open the scanner when the document cover is open.

3. Press and release the  ink button. The  On and  ink lights flash.

If one of the cartridges is low or expended, the CX5000 Series moves that cartridge to the  expended ink mark. Go to step 4.

If no cartridges are low or expended, the ink cartridge holder moves to the ink replacement position. Go to step 4.

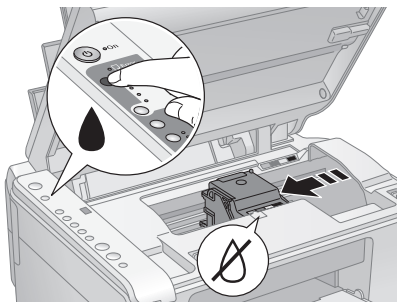



Note:

Do not hold down the  ink button for more than 3 seconds or the printer will start to clean the print head.

Caution:

Do not move the print head by hand; this may damage the CX5000 Series. Always press the  ink button to move it.

4. Press the  ink button again.
 - If more than one cartridge is low or expended, the next cartridge moves to the  expended ink mark.
 - Once the CX5000 Series identifies all of the low or expended ink cartridges, the print head moves to the ink cartridge replacement position.

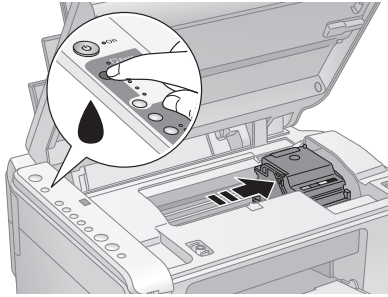

5. Open the cartridge cover.

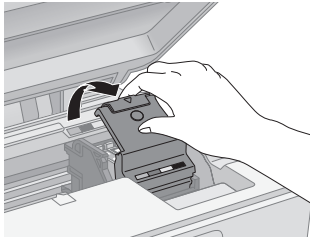

Caution:

Never attempt to open the cartridge cover when the print head is moving. Wait until the cartridges have moved to the replacement position.

6. Squeeze the tab at the back of the cartridge and lift it straight out. Dispose of it carefully. Do not take the used cartridge apart or try to refill it.

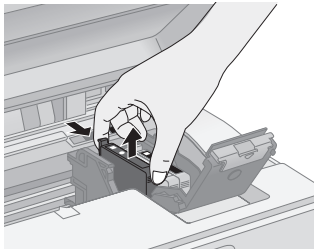

Warning:

If ink gets on your hands, wash them thoroughly with soap and water. If ink gets into your eyes, flush them immediately with water.

7. Before you open the new ink cartridge package, shake it four or five times. Then remove it from the package.

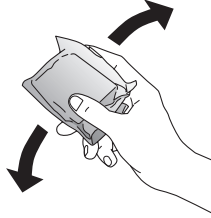

Caution:

Do not touch the green chip on the front of the cartridge. This can damage the ink cartridge.

8. Remove the yellow tape from the bottom of the ink cartridge.

Caution:

If you do not remove the yellow tape before installing the ink cartridge, print quality may decline or you may not be able to print.

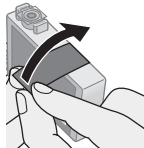

Caution:

Do not remove any other seals from the cartridges.



9. Place the new ink cartridge into the cartridge holder and push it down until it clicks into place.

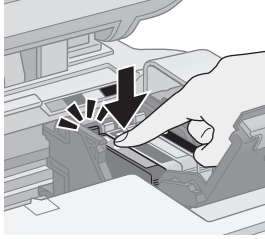

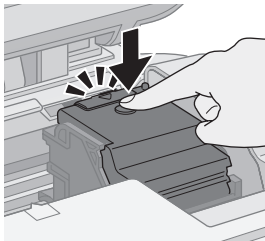

10. Replace any other cartridges that need to be replaced.

11. Close the ink cartridge cover and press it until it clicks into place.

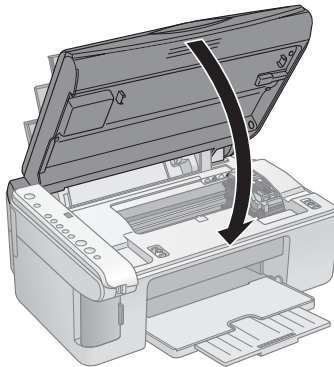

12. Close the scanner.





13. Press the  ink button. The CX5000 Series begins charging ink and the On light starts flashing. This takes about one minute. When it's finished, the On light stops flashing and remains on, and the  ink light goes out.

Caution:

Never turn off the CX5000 Series while the On light is flashing or you'll waste ink.

If you removed a low or expended ink cartridge, you cannot reinstall and use the cartridge.

Note:

If the  ink light stays on (not flashing), the ink cartridge may not be installed correctly. Press the  ink button again and reinstall the ink cartridge until it clicks into place.

If you replaced a cartridge while copying a document or photo, cancel printing and make sure your original is still placed correctly on the document table. Then copy your original again.

Solving Problems

If you have a problem with your Epson Stylus CX5000 Series all-in-one, check the lights on the control panel and the number or letter in the **Copies** window to diagnose the cause.









You can also check “Problems and Solutions” on page 42 for basic troubleshooting suggestions, or double-click the *User’s Guide* icon on your computer desktop for more detailed help.

See these sections:

- “Error Indicators” (below)
- “Problems and Solutions” on page 42
- “Where To Get Help” on page 44

Error Indicators

Light: status	Copies window status	Cause	Solution
⏻ On: Flashing ❏ Error: On	—	No paper is loaded in the sheet feeder.	Load paper in the sheet feeder. Then press Start Color to continue or Stop to cancel. See page 5.
	—	Multiple pages have been fed into the sheet feeder.	Remove and reload the paper. Then press Start Color to continue or Stop to cancel. See page 5.
❏ Error: Flashing	—	Paper is jammed.	See page 43.
◆ Ink: Flashing	—	An ink cartridge is running low on ink.	See page 34.
◆ Ink: On	—	An ink cartridge is expended or not installed correctly.	See page 34.

Light: status	Copies window status	Cause	Solution
 Error: Flashing Memory Card (all 3 lights): Flashing	1	An unsupported memory card is inserted.	Remove the incompatible memory card; see page 13.
		The inserted memory card does not contain any valid images.	See page 13 for a list of compatible card and image types.
 Error: Flashing Print From Index Sheet: Flashing	2	An index sheet was not recognized because it is not positioned correctly.	Position the index sheet correctly on the glass, aligning the top of it with the left edge of the glass. Then press  Start Color to continue or  Stop to cancel.
	3	The index sheet is marked incorrectly. (No marks are detected or the sheet includes more than one mark for an image.)	Remove the index sheet, mark it correctly, and try again; see page 16.
	4	The index sheet does not match the photos on the memory card.	Remove the memory card and insert the card used to print the index sheet (see page 14 for instructions)—or place the correct index sheet on the glass. Then press  Start Color to continue or  Stop to cancel.
 Error: Flashing Print All/ PictBridge: Flashing	P	An unsupported device is connected to the  (USB) port on the front.	Disconnect the device.

Light: status	Copies window status	Cause	Solution
<input type="checkbox"/> Error: Flashing fast	H	The paper thickness lever is set to the <input checked="" type="checkbox"/> H position.	If you have set the lever to the <input checked="" type="checkbox"/> H position because you are printing envelopes, press <input type="checkbox"/> Start Color to continue. Otherwise, set the lever to the <input type="checkbox"/> L position.
<input type="checkbox"/> Error: On ◆ Ink: On All other lights: Flashing	E	A CX5000 Series part needs to be replaced.	Contact your local authorized servicer or contact Epson for a referral; see page 44.
All lights: Flashing	E	There is a problem with the CX5000 Series.	Turn the CX5000 Series off and then back on. If the error does not clear, contact your local authorized servicer or contact Epson for a referral; see page 44.

Problems and Solutions

Check the solutions below if you're having trouble using your Epson Stylus CX5000 Series all-in-one.

Printing and Copying Problems

- Make sure your original is positioned in the top left corner of the glass. If the edges are cropped, move your original away from the edges slightly.
- Make sure your paper is loaded short edge first and is positioned against the right edge guide with the left edge guide against its left side. Don't load paper above the arrow mark inside the left edge guide.
- Make sure the paper size settings are correct for the paper you loaded.

Paper Feeding Problems

- If paper doesn't feed, remove it from the sheet feeder. Flip through the stack to separate the sheets a little. Then reload the paper against the right edge guide, and slide the left edge guide against the paper (but not too tightly). Make sure the paper is not in front of the feeder guard.
- Do not load too many sheets at once (up to 20 sheets of photo or matte paper and 100 sheets of plain paper). See the *User's Guide* for more information.
- If paper is jammed, the red  Error light flashes.



Follow these steps to clear the jam:

1. Press the  **Start Color** button to eject the jammed paper. If the jammed paper is not ejected, go to the next step.
2. If the paper is stuck near the sheet feeder or output tray, gently pull it out.

If the paper is stuck inside, press the  **On** button to turn it off. Open the scanner and remove any paper inside, including any torn pieces. Do not pull it backward however; this can damage the sheet feeder. Close the scanner, then turn the CX5000 Series back on.

Print Quality Problems

If you have any problems with the copy or print quality, try these solutions:

- Make sure the document is placed flat against the document table glass and the CX5000 Series is not tilted or placed on an uneven surface.
- Load the paper printable side up (usually the whiter, brighter, or glossy side).
- Make sure your paper isn't damp or curled.
- Use a support sheet with special paper or load your paper one sheet at a time. Remove sheets from the output tray so not too many collect at a time.
- Make sure the type of paper you loaded matches the paper size and paper type settings on the control panel or in your printer software (see page 26).
- For the best print quality, use Epson special paper (see page 26) and genuine Epson ink cartridges (see page 35).
- Set the paper thickness lever to the  L position for most paper types. If you are printing on envelopes, set the lever to the  H position.

- If you notice light or dark bands across your printouts or they are too faint, you may need to clean the print head. This unclogs the nozzles so they can deliver ink properly. Run a nozzle check as described on page 32 to see if the print head needs cleaning.
- Clean the print head as described on page 33.
- If you notice jagged vertical lines, you may need to align the print head. See your *User's Guide* for instructions.
- The ink cartridges may be old or low on ink (see page 35 for instructions on replacing an ink cartridge).
- If a dotted line appears in the image, clean the scanner glass with a soft, dry, lint-free cloth (paper towels are not recommended), or use a small amount of glass cleaner on a soft cloth, if necessary. Do not spray glass cleaner directly on the glass.

Where To Get Help

Epson Technical Support

Epson provides these technical support services:

Internet Support

Visit Epson's support website at epson.com/support and select your product for solutions to common problems. You can download drivers and documentation, get FAQs and troubleshooting advice, or e-mail Epson with your questions.

Speak to a Support Representative

Before you call Epson for support, please have the following information ready:

- Product name (Epson Stylus CX5000 Series)
- Product serial number (located on the label in back)
- Proof of purchase (such as a store receipt) and date of purchase
- Computer configuration
- Description of the problem

Then call:

- U.S.: (562) 276-4382, 6 AM to 6 PM, Pacific Time, Monday through Friday.
- Canada: (905) 709-3839, 6 AM to 6 PM, Pacific Time, Monday through Friday.

Toll or long distance charges may apply.

Purchase Supplies and Accessories

You can purchase genuine Epson ink and paper from an Epson authorized reseller. To find the nearest reseller, call 800-GO-EPSON (800-463-7766). Or you can purchase online at www.epsonstore.com (U.S. sales) or www.epson.ca (Canadian sales).

Other Software Technical Support

Software	Telephone/Fax	Online and E-mail
ArcSoft PhotoImpression	(510) 440-9901 8:30 AM - 5:30 PM, Pacific Time, Monday - Friday Fax: (510) 440-1270	www.arcsoft.com support@arcsoft.com

Notices

Important Safety Instructions

Before using your Epson Stylus CX5000 Series all-in-one, read and follow these safety instructions:

- Be sure to follow all warnings and instructions marked on the CX5000 Series.
- Use only the type of power source indicated on the CX5000 Series label.
- Use only the power cord that comes with the CX5000 Series. Use of another cord may cause fires or shock. Do not use the cord with any other equipment.
- Place the CX5000 Series near a wall outlet where the plug can be easily unplugged.
- Do not let the power cord become damaged or frayed.
- If you use an extension cord with the CX5000 Series, make sure the total ampere rating of the devices plugged into the extension cord does not exceed the cord's ampere rating. Also, make sure the total ampere rating of all devices plugged into the wall outlet does not exceed the wall outlet's ampere rating.
- Avoid locations that are subject to rapid changes in heat or humidity, shocks or vibrations, or dust.
- Leave enough room around the CX5000 Series for sufficient ventilation. Do not block or cover openings in the CX5000 Series case or insert objects through the slots.
- Do not place the CX5000 Series near a radiator or heating vent or in direct sunlight.
- Place the CX5000 Series on a flat, stable surface that extends beyond its base in all directions. It will not operate properly if it is tilted or at an angle.
- Make sure the back of the CX5000 Series is at least 4 inches (10 cm) away from the wall.
- Do not open the scanner section while the CX5000 Series is copying, printing, or scanning.
- Do not spill liquid on the CX5000 Series.
- Except as specifically explained in your documentation, do not attempt to service the CX5000 Series yourself.

- Unplug the CX5000 Series and refer servicing to qualified service personnel under the following conditions: if the power cord or plug is damaged; if liquid has entered the product; if the product has been dropped or the case damaged; if the product does not operate normally or exhibits a distinct change in performance. Adjust only those controls that are covered by the operating instructions.
- When storing or transporting the CX5000 Series, do not tilt it, stand it on its side, or turn it upside down; otherwise ink may leak from the cartridge.
- Please consult your state and local regulations regarding disposal or recycling. Do not put in the trash.

Ink Cartridge Safety Instructions

- Keep ink cartridges out of the reach of children and do not drink the ink.
- Be careful when you handle used ink cartridges; there may be ink remaining around the ink supply port. If ink gets on your skin, wash it off with soap and water. If it gets in your eyes, flush them immediately with water.
- Do not put your hand inside the CX5000 Series or touch any cartridges during printing.
- Install a new ink cartridge immediately after removing an expended one. Leaving cartridges uninstalled can dehydrate the print head and may prevent the CX5000 Series from printing.
- If you remove an ink cartridge for later use, protect the ink supply area from dirt and dust and store it in the same environment as the CX5000 Series. Note that there is a valve in the ink supply port, making covers or plugs unnecessary, but care is needed to prevent the ink from staining items that the cartridge touches. Do not touch the ink cartridge ink supply port or surrounding area.

FCC Compliance Statement

For United States Users

This equipment has been tested and found to comply with the limits for a Class B digital device, pursuant to Part 15 of the FCC Rules. These limits are designed to provide reasonable protection against harmful interference in a residential installation. This equipment generates, uses, and can radiate radio frequency energy and, if not installed and used in accordance with the instructions, may cause harmful interference to radio or television reception. However, there is no guarantee that interference will not occur in a particular installation. If this equipment does cause interference to radio and television reception, which can be determined by turning the equipment off and on, the user is encouraged to try to correct the interference by one or more of the following measures:

- Reorient or relocate the receiving antenna.
- Increase the separation between the equipment and receiver.
- Connect the equipment into an outlet on a circuit different from that to which the receiver is connected.
- Consult the dealer or an experienced radio/TV technician for help.

WARNING

The connection of a non-shielded equipment interface cable to this equipment will invalidate the FCC Certification of this device and may cause interference levels which exceed the limits established by the FCC for this equipment. It is the responsibility of the user to obtain and use a shielded equipment interface cable with this device. If this equipment has more than one interface connector, do not leave cables connected to unused interfaces. Changes or modifications not expressly approved by the manufacturer could void the user's authority to operate the equipment.

For Canadian Users

This Class B digital apparatus complies with Canadian ICES-003.

Cet appareil numérique de la classe B est conforme à la norme NMB-003 du Canada.

Declaration of Conformity

According to 47CFR, Part 2 and 15 for: Class B Personal Computers and Peripherals;
and/or CPU Boards and Power Supplies used with Class B Personal Computers:

We: Epson America, Inc.
Located at: MS 3-13
3840 Kilroy Airport Way
Long Beach, CA 90806
Telephone: (562) 290-5254

Declare under sole responsibility that the product identified herein, complies with 47CFR Part 2 and 15 of the FCC rules as a Class B digital device. Each product marketed is identical to the representative unit tested and found to be compliant with the standards. Records maintained continue to reflect the equipment being produced can be expected to be within the variation accepted, due to quantity production and testing on a statistical basis as required by 47CFR §2.909. Operation is subject to the following two conditions: (1) this device may not cause harmful interference, and (2) this device must accept any interference received, including interference that may cause undesired operation.

Trade Name: Epson
Type of Product: Multifunction printer
Model: C231C

Epson America, Inc., Limited Warranty

What Is Covered: Epson America, Inc. (“Epson”) warrants to the original retail purchaser that the Epson printer covered by this limited warranty statement, if purchased and operated only in the United States or Canada, will be free from defects in workmanship and materials for a period of one (1) year from the date of original purchase. For warranty service, you must provide proof of the date of original purchase.

What Epson Will Do To Correct Problems: Should your Epson printer prove defective during the warranty period, please call the Epson ConnectionSM at (562) 276-4382 (U.S.) or (905) 709-3839 (Canada) for warranty repair instructions and return authorization. An Epson service technician will provide telephone diagnostic service to determine whether the printer requires service. If service is needed, Epson will, at its option, exchange or repair the printer without charge for parts or labor. If Epson authorizes an exchange for the defective unit, Epson will ship a replacement printer to you, freight prepaid, so long as you use an address in Canada or the U.S. (excluding Puerto Rico and U.S. Possessions). Shipments to other locations will be made freight collect. You are responsible for securely packaging the defective unit and returning it to Epson within five (5) working days of receipt of the replacement. Epson requires a debit or a credit card number to secure the cost of the replacement printer in the event that you fail to return the defective one. If your printer is being repaired, Epson will direct you to send your printer to Epson or its authorized service center, where the printer will be fixed and sent back to you. You are responsible for packing the printer and for all costs to and from the Epson authorized service center. When warranty service involves the exchange of the printer or a part, the item replaced becomes Epson property. The replacement printer or part may be new or refurbished to the Epson standard of quality, and, at Epson’s option, may be another model of like kind and quality. Epson’s liability for replacement of the covered printer will not exceed the original retail selling price of the covered printer. Exchange products and parts assume the remaining warranty period of your original product covered by this limited warranty.

What This Warranty Does Not Cover: This warranty does not apply to refurbished or reconditioned products. This warranty covers only normal use in the United States and Canada. Using this product for continuous production or similar high duty purposes is not considered normal use; damage, maintenance or service from such use will not be covered under this warranty. This warranty is not transferable. This warranty does not cover any color change or fading of prints or reimbursement of materials or services required for reprinting. This warranty does not cover damage to the Epson product caused by parts or supplies not manufactured, distributed or certified by Epson. This warranty does not cover ribbons, ink cartridges or third party parts, components, or peripheral devices added to the Epson product after its shipment from Epson, e.g., dealer or user-added boards or components. Epson is not responsible for warranty service should the Epson label or logo or the rating label or serial number be removed or should the product

fail to be properly maintained or fail to function properly as a result of misuse, abuse, improper installation, neglect, improper shipping, damage caused by disasters such as fire, flood, and lightning, improper electrical current, software problems, interaction with non-Epson products, or service other than by an Epson Authorized Servicer. If a claimed defect cannot be identified or reproduced, you will be held responsible for the costs incurred.

THE WARRANTY AND REMEDY PROVIDED ABOVE ARE EXCLUSIVE AND IN LIEU OF ALL OTHER EXPRESS OR IMPLIED WARRANTIES INCLUDING, BUT NOT LIMITED TO, THE IMPLIED WARRANTIES OF MERCHANTABILITY, NON-INFRINGEMENT OR FITNESS FOR A PARTICULAR PURPOSE. SOME LAWS DO NOT ALLOW THE EXCLUSION OF IMPLIED WARRANTIES. IF THESE LAWS APPLY, THEN ALL EXPRESS AND IMPLIED WARRANTIES ARE LIMITED TO THE WARRANTY PERIOD IDENTIFIED ABOVE. UNLESS STATED HEREIN, ANY STATEMENT OR REPRESENTATIONS MADE BY ANY OTHER PERSON OR FIRM ARE VOID. EXCEPT AS PROVIDED IN THIS WRITTEN WARRANTY, NEITHER EPSON AMERICA, INC. NOR ITS AFFILIATES SHALL BE LIABLE FOR ANY LOSS, INCONVENIENCE, OR DAMAGE, INCLUDING DIRECT, SPECIAL, INCIDENTAL OR CONSEQUENTIAL DAMAGES, RESULTING FROM THE USE OR INABILITY TO USE THE EPSON PRODUCT, WHETHER RESULTING FROM BREACH OF WARRANTY OR ANY OTHER LEGAL THEORY.

In Canada, warranties include both warranties and conditions.

Some jurisdictions do not allow limitations on how long an implied warranty lasts, and some jurisdictions do not allow the exclusion or limitation of incidental or consequential damages, so the above limitations and exclusions may not apply to you. This warranty gives you specific legal rights and you may have other rights which vary from jurisdiction to jurisdiction.

To find the Epson Authorized Reseller nearest you, visit our website at:
<http://www.epson.com>.

To find the Epson Customer Care Center nearest you, visit: <http://support.epson.com>.

You can also write to: Epson America, Inc., P.O. Box 93012, Long Beach, CA 90809-3012

Copyright Notice

All rights reserved. No part of this publication may be reproduced, stored in a retrieval system, or transmitted in any form or by any means, electronic, mechanical, photocopying, recording, or otherwise, without the prior written permission of Seiko Epson Corporation. The information contained herein is designed only for use with this Epson product. Epson is not responsible for any use of this information as applied to other equipment.

Neither Seiko Epson Corporation nor its affiliates shall be liable to the purchaser of this product or third parties for damages, losses, costs, or expenses incurred by purchaser or third parties as a result of: accident, misuse, or abuse of this product or unauthorized modifications, repairs, or alterations to this product, or (excluding the U.S.) failure to strictly comply with Seiko Epson Corporation's operating and maintenance instructions.

Seiko Epson Corporation shall not be liable for any damages or problems arising from the use of any options or any consumable products other than those designated as Original Epson Products or Epson Approved Products by Seiko Epson Corporation.

Responsible Use of Copyrighted Materials

Epson encourages each user to be responsible and respectful of the copyright laws when using any Epson product. While some countries' laws permit limited copying or reuse of copyrighted material in certain circumstances, those circumstances may not be as broad as some people assume. Contact your legal advisor for any questions regarding copyright law.

Trademarks

Epson and Epson Stylus are registered trademarks and Exceed Your Vision is a trademark of Seiko Epson Corporation.

DURABrite is a registered trademark and Epson Connection is a service mark of Epson America, Inc.

USB DIRECT-PRINT and the USB DIRECT-PRINT logo are trademarks of Seiko Epson Corporation. Copyright © 2002 Seiko Epson Corporation. All rights reserved.

DPOF is a trademark of CANON INC., Eastman Kodak Company, Fuji Photo Film Co., Ltd. and Matsushita Electric Industrial Co., Ltd.

SD is a trademark.

SDHC is a trademark.

Memory Stick is a registered trademark, and Memory Stick Duo, Memory Stick PRO, Memory Stick PRO Duo, MagicGate, MagicGate Memory Stick, and MagicGate Memory Stick Duo are trademarks of Sony Corporation.

xD-Picture Card is a trademark of Fuji Photo Film Co.,Ltd.



General Notice: Other product names used herein are for identification purposes only and may be trademarks of their respective owners. Epson disclaims any and all rights in those marks.

© 2006 Epson America, Inc. 12/06

EPSON[®]
EXCEED YOUR VISION



410923100

CPD-21812R2
Printed in XXXXXX XX.XX-XX XXX