



Ethernet Access Residential Unit 1103 (EARU 1103)



Please read this manual carefully before operating your set.
Retain it for future reference.

C O N T E N T S

3	Product and personal safety guidelines
8	Regulatory information
11	About EARU 1103
14	Checking package contents
16	Installing EARU 1103
27	Setting EARU 1103
28	Open Source Software Notice

Product and personnel safety guidelines

This section contains safety guidelines that you must follow for personal safety and to operate the equipment correctly.

LG-Ericsson documentation contains precautionary messages and safety procedures that refer to specific tasks or conditions. You must read and follow all precautionary messages before you start to work on the equipment.

Audience





Personnel working directly on equipment must be

- trained, authorized, and qualified to carry out the tasks required
- able to follow safety guidelines specific to the product and all local customer-specific safety procedures

Precautionary messages

To prevent personal injury, equipment damage, and service interruptions, you must follow all precautionary messages in LG-Ericsson documentation and all local safety standards required by your service provider.

The following precautionary messages appear in LG-Ericsson documentation:

	DANGER Risk of personal injury A precautionary message with this symbol indicates a risk of personal injury.
	DANGER Risk of electrical shock A precautionary message with this symbol indicates a risk of personal injury caused by an electrical hazard.
	WARNING Risk of laser radiation exposure A precautionary message with this symbol indicates a potential risk of personal injury caused by exposure to a laser beam.
	CAUTION Risk of laser radiation exposure A precautionary message with this symbol indicates a potential risk of personal injury caused by exposure to a laser beam.

Safety standards

LG-Ericsson products conform to all relevant safety standards. The EARU 1103 complies with the following safety standards:

- IEC 60950-1:2005+A1:2009 and EN 60950-1:2006+A11:2009—Information technology equipment - Safety, Part 1 : General requirements
- IEC 60825-1:2001 and IEC 60825-2:2004—Safety of Laser Products
- FDA 21 CFR 1040—Performance Standards for Light-Emitting Products

Laser radiation—eye safety hazards

LG-Ericsson optical products use laser or light-emitting diode (LED) sources that emit light energy into optical fibers. This energy is within the red (visible) and infrared (not visible) areas of the electromagnetic spectrum. FDA 21 CFR 1040—Performance Standards for Light-Emitting Products

Laser radiation hazards

correctly terminated, the optical radiation is completely enclosed. The system is a Class 1 (IEC)/Class I (FDA) product, regardless of the power transmitted within the optical fiber.

If you have unterminated optical cables (breaks in the fiber-optic cable or disconnected connectors) the output from circuit packs containing optical transmitters does not exceed Class 1 (IEC)/Class I (FDA) and is therefore considered safe under all reasonably foreseeable conditions.

The following text includes additional information on the laser for the EARU 1103 .

<p>Laser wavelength 1530 - 1600 nm</p> <p>Maximum laser output power ≤ 0.299 mW (-5.25 dBm)</p> <p>Standards: IEC 60825-1:2001 Edition 1.2</p> <p>FDA 21 CFR 1040.10:2000</p>
--

Using optical fibers

All activity described herein regarding the optical interface of the EARU 1103 is intended only for trained personnel operating under the direction of the service provider. Users and homeowners should not attempt to access or disconnect the optical interface or damage the optical cable. Consult with the service provider before undertaking any action involving the optical interface.

Handling optical fibers

When you work with optical fibers, you must take the following general precautions:

- Wear safety glasses when you install optical fibers.



WARNING

Risk of laser radiation exposure

Do not look directly into the optical beam. Invisible light can severely damage your eyes. Keep all optical connectors capped.

- Do not look into the opening of an optical fiber, or the opening of an optical fiber connector, if the optical fiber is active or the unit has the power turned on.
- Avoid direct exposure to optical fiber ends or optical connector ends where you can access the laser signal directly.
- Clean your hands after you handle optical fibers. Small pieces of glass are not always visible and can damage your eyes.



DANGER

Risk of eye injury

If you have a piece of a glass in your eye, get medical assistance immediately.

- Do not handle pieces of optical fiber with your fingers. Use tweezers or adhesive tape to lift and discard any loose optical fiber ends.
- Wear rubber gloves when you clean optical connectors. The gloves prevent direct contact with the isopropyl alcohol and prevent contamination of the ferrules with skin oils.
- Place all optical fiber clippings in a plastic container provided for that purpose.
- Handle optical fibers with caution. Place the optical fibers in a safe location during installation.
- Protect all optical fiber connectors with clean dust caps at all times.
- Follow the manufacturer instructions when you use an optical test set. Incorrect calibration or control settings can create hazardous levels of radiation.

Splicing optical fibers

When you must look at a spliced optical fiber with a small magnifier, take the following precautions:

- Power off all laser sources to the optical fiber or disconnect the remote optical fiber end from the laser sources before you start splicing. Make sure that all laser sources remain disconnected or have the power turned off.
- Disconnect all optical test sets from the optical fiber before you start splicing. The connections can be local or remote.
- Use only the optical instruments approved by your company.

Repairing optical fibers

When an accidental break occurs in the optical fiber, do the following:

- Report the location of the damaged optical fiber to both the service provider and the field repair personnel.
- Power down all laser sources to the optical fiber or disconnect the remote optical fiber end from the laser sources.

Working with power



DANGER

Risk of electrical shock

The (AC) mains connection from the power adapter to the power supply can be a shock hazard. Read and understand the power procedures you are performing. Take necessary precautions and use the appropriate insulated tools when working with power.

Other Warnings and cautions

WARNINGS



Do not disassemble this product.

This can cause poor performance of the product or result in a fire, or injury from electric shock. If you experience trouble, contact the service provider.



Do not expose this product to liquid or install this product in a humid location. If the product does get wet, contact your service provider.

This can cause poor performance of the product or result in a fire, or injury from electric shock.



If the product has an abnormal smell, noise or if you see smoke, disconnect the power or turn it off if it safe to do so and contact your service provider.

This can result in a fire, or injury from electric shock.

CAUTIONS



Keep the fiber connected at all times. Do not remove it.
It is recommended that the fiber remains connected in your fiber port. This will reduce the possibility of dust contamination which would impact performance.



DO NOT pull on the optical cable.
This can cause poor performance and failure of the product.



Do not stack anything on this product.
This can cause poor performance and failure of the product.



DO NOT install the product in a dusty site.
This can cause poor performance or reduced life cycle of the product.



DO NOT install the product under direct sun rays or near heating appliances.
This can cause poor performance and failure of the product.



DO NOT install the product in a poor-ventilated site.
This can cause poor performance or reduced life cycle of the product.



Do not clean this product with any type of cleaning agents or water.
This can damage the product. Use a dry, clean cloth to remove dust.

Warranty: Customers can receive repair services for this product under specified conditions. This warranty does not cover failure or damage of the product caused from, using a power adapter other than the one provided, PC failures, data loss, or negligent treatment of the product.

Regulatory information

This chapter contains the following information:

- a list of global technical standards (electromagnetic compatibility, safety) to which the EARU 1103 complies
- a country-by-country list of specific regulatory text required by national authorities
- information on the regulatory labels affixed to the product (artwork and location on the product)

The list of global technical standards provided in this chapter is not exhaustive.

The standards listed are generally regarded as the primary applicable electromagnetic compatibility (EMC) and safety standards. The conformity status on additional national and international standards not listed in this section can be provided upon request.

Compliance to applicable technical standards and regulations

The EARU 1103 meets or exceeds the following standards and requirements:

- (CFR Title 47, Chapter 1) FCC Part 15, Subpart B, Class B (USA)
- ICES-003, Issue 4, Class B (Canada)
- European Union EMC Directive (2004/108/EC)
- European Radio and Telecommunications Terminal Equipment Directive (R&TTE, 1999/5/EC)
- European "Low Voltage" Directive (2006/95/EC)
- EN 55022:2006 - Class B (European Community, Australia and New Zealand)
- EN 55024:1998 +A1:2001 +A2:2003 (European Community)
- EN 300 386 V1.3.3 (European Community, Australia and New Zealand)
- Anatel Resolution Number 442:2006 (Brazil)
- GB 9254-2000 (China)
- VCCI V-3/2007.04 (Japan)
- Australian Radiocommunications Labelling (Electromagnetic Compatibility) Notice 2008
- CAN/CSA-C22.2 No. 60950-1 2nd edition (Canada)
- UL60950-1 2nd edition (USA)
- IEC 60950-1:2005+A1:2009
- EN 60950-1:2006+A11:2009
- IEC/EN 60825-1:2001
- IEC/EN 60825-2:2004
- AS/NZS 2211.1:2004 (Australia and New Zealand)
- AS/NZS 2211.2:2006 (Australia and New Zealand)
- Resolution 238:2000 (Brazil)
- GB 4943-1995 (China)

Country-specific regulatory information

Canada

This Class B digital apparatus complies with Canadian ICES-003.

Cet appareil numérique de la classe B est conforme à la norme NMB-003 du Canada.

United States of America

This equipment has been tested and found to comply with the limits for a Class B digital device, pursuant to part 15 of the FCC Rules. These limits are designed to provide reasonable protection against harmful interference in a residential installation. This equipment generates, uses and can radiate radio frequency energy and, if not installed and used in accordance with the instructions, may cause harmful interference to radio communications. However, there is no guarantee that interference will not occur in a particular installation. If this equipment does cause harmful interference to radio or television reception, which can be determined by turning the equipment off and on, the user is encouraged to try to correct the interference by one or more of the following measures:

- Reorient or relocate the receiving antenna.
- Increase the separation between the equipment and receiver.
- Connect the equipment into an outlet on a circuit different from that to which the receiver is connected (consult with the service provider before proceeding).
- Consult the service provider or an experienced radio/TV technician for help.

Repairs to certified equipment should be coordinated by a representative designated by your service provider. Any repairs or alterations made by the user to this equipment, or equipment malfunctions, may give the service provider cause to request the user to disconnect the equipment.

Do not attempt to repair this equipment. If you experience trouble, contact the service provider.

FCC Warning

This equipment generates or uses radio frequency energy. Changes or modifications to this equipment may cause harmful interface unless the modifications are expressly approved in the instruction manual. The user could lose the authority to operate this equipment if an unauthorized change or modification is made.

European Union

The EARU 1103 conforms with the essential requirements of Directive 2004/108/EC (EMC Directive), Directive 2006/95/EC (Low Voltage Directive) and Directive 1999/5/EC (Radio and Telecommunications Terminals Equipment) through compliance to the following harmonized standards:

- EN 55022:2006 (Class B)
- EN 55024:1998 +A1:2001 +A2:2003
- EN 300 386 V1.3.3 (Class B, other than telecommunications centres criteria)

- EN 60950-1:2006 +A11:2009
- EN 60825-1:2001
- EN 60825-2:2004

The product bears the CE mark as illustrated in figures on page14.

A signed Declaration of Conformity is available upon request.

Brazil

The EARU 1103 conforms with the requirements of Anatel Resolution Number 442:2006 (EMC) for a Class B product and Anatel Resolution NR 238:2000 for product safety.

Japan

この装置は、情報処理装置等電波障害自主規制協議会（VCCI）の基準に基づくクラスB情報技術装置です。この装置は、家庭環境で使用することを目的としていますが、この装置がラジオやテレビジョン受信機に近接して使用されると、受信障害を引き起こすことがあります。

取扱説明書に従って正しい取り扱いをして下さい。

(English translation)

This is a Class B product based on the standard of the Voluntary Control Council for Interference from Information Technology Equipment (VCCI). If this is used near a radio or television receiver in a domestic environment, it may cause radio interference. Install and use the equipment according to the instruction manual.

Australia / New Zealand

The EARU 1103 complies with EN 55022:2006 (Class B) and EN 300 386 V1.3.3 (Class B) in respect of the EMC regulatory arrangements of the Radiocommunications Act 1992 of the Australian Communications And Media Authority, in particular, the Radiocommunications Labelling (Electromagnetic Compatibility) Notice 2008, and of the New Zealand Ministry of Economic Development.

The product bears the C-tick mark as illustrated in figures on page14.

A signed Declaration of Conformity is available upon request.

Regulatory labels (Safety and EMC)

The following labels have been placed on the system and various field replaceable units (FRU).

The main product-level regulatory label is located on the rear side of the EARU 1103. See page14. The label bears the product name, power ratings information, certification and other regulatory marks and informational disclosures required by jurisdictional authorities.

After reading through this User's Manual, please keep it handy for easy reference.

About EARU 1103

Thank you for selecting EARU 1103 .

The EARU 1103 is an equipment working as a modem in WDM-PON (Wavelength Division Multiplexing - Passive Optical Network).

This product multiplexes 125Mbps to 100Mbps Fast Ethernet signals (maximum 4ea) into WDM-PON optical signal.

This product will allow you to use the different services such as VoD (Video on Demand), EoD (Education on Demand) , IP-TV, POTS, and High speed internet access available from your provider.

Names and functions of each part

Front view

Closed view



Open view

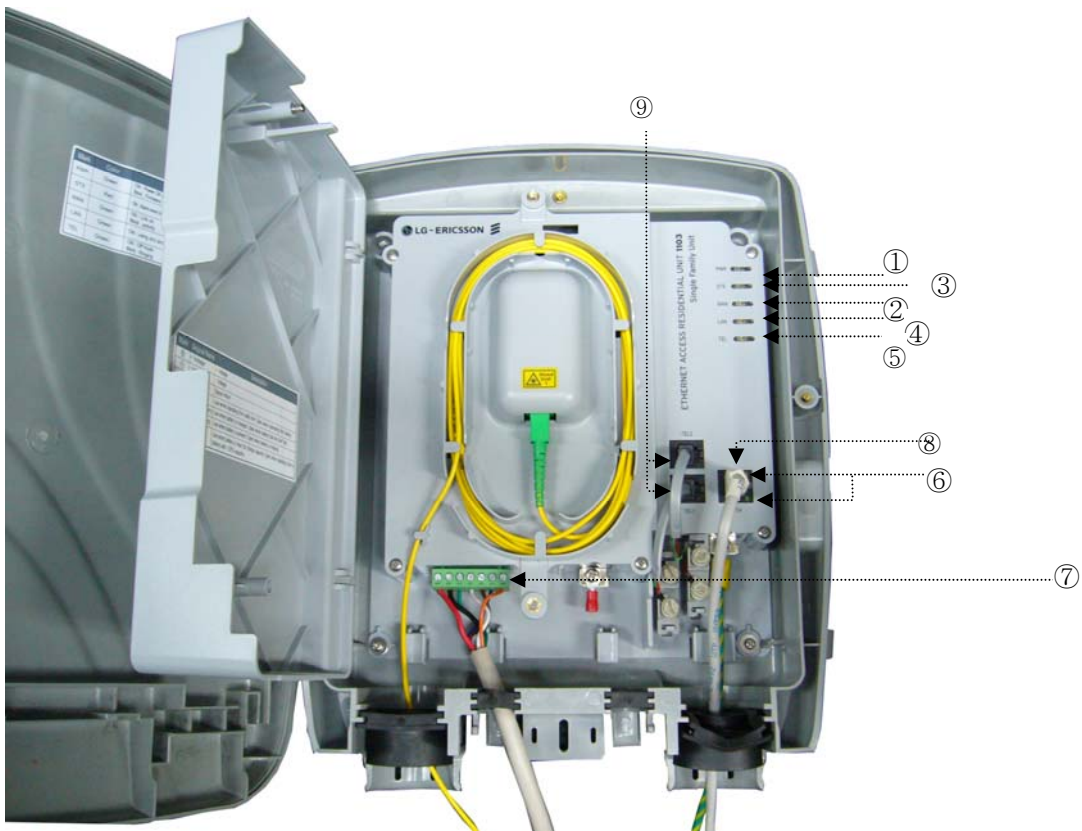

LEDs and Ports functions

Number	Indicator	Usage	Color	Function	
①	PWR	Power display	Green	ON : Power OK and normal status Blink : Firmware Downloading	
②	STS	Status display	Red	ON : Alarm event	
①+ ② Combination				Blink (by turns) : CPU booting Blink (at once) : Main application loading Green OFF, Red ON : Boot Fail Green OFF, Red OFF : Check power supply	
③	L E D	WAN Network display	Green	ON : Link ON Blink : Activity	
④		LAN Ethernet display	Green	ON : Link Blink : activity	
⑤		TEL POTS display	Green	ON : Off Hook Blink : Ringing	
⑥		FE (in RJ-45)	Ethernet display	Green	ON : Link Blink : activity
				Orange	ON : 100Base-T OFF : 10Base-T
⑦		BATT	Power input	-	Port for the Battery interface.
⑧	ETH1	For connection to Ethernet	-	Ethernet ports that will connect to user devices supporting 10/100 Mbps.	
⑨	TEL1-2	For connection to POTS	-	POTS ports that will connect to user devices supporting Telephone.	

Labels



Number	item	Label	Location
1	PEC & SN Label 9.652mm x 27.94mm		Side & inside
2	Hazard level 1 9.5mm x 15mm		Inside
3	Regulatory 40mm x 81mm		Inside

Note: ① labels should be placed inside and outside.

Specifications

Item	Specification
Dimensions in mm	251mm(w) x 97(d) x 323(h)
Power	DC 12V, 1A
Ambient Temperature	-40°C to 65°C
Humidity	20% to 80%
Technical standards	EN 300 386 (Class B, other than Telecom Centres) FCC part 15 (CFR 47) (Class B) EN 55022 (Class B) / 55024
Pollution Degree	2
Overvoltage Category	II
Data rate	100Mbps
Connectors	SC/APC (optical), RJ45 (Ethernet), RJ11(POTS)
LED indicators	PWR, STS,WAN,LAN,TEL

Checking package contents

Before installing this product, ensure all parts are provided.

Checking what is in the package

Check the package to make sure the following items are included.



EARU 1103 Main body



UPS (option)



User manual

Mounting packaging list

The mounting kit is optional according to your installation environment.

- Wall mounting kit list

No.	Item Name	Quantity	Item Number
1	EARU1103 BODY	1	
2	SPRIAL PLASTIC PLUG(BN309-7-34)	2	P04929-00
3	SCREW(BN695-4.8-38)	2	P04928-00
4	WALL MOUNTING DRILL TEMPLATE	1	N04647-00

- Pole mounting kit list

No.	Item Name	Quantity	Item Number
1	POLE MOUNTING BRACKET	1	M05801-00
2	CLAMP	2	M05815-00
3	SCREW(BN660-5-25)	2	P04963-00
4	WASHER(BN670-5)	2	P04962-00
5	POLE MOUNTING KIT INSTALLATION	1	M05816-00
6	AIR CAP VINYL BAG	2	
7	ZIPPER VINYL BAG	2	
8	VINYL BAG	1	

Installing EARU 1103

This section provides the specifications for EARU 1103 installation, it also describes how to install it and connect it into a network.

Installation environments

Install the EARU 1103 in an environment where the following specifications are met.

- Operating temperature: -40°C to 65°C
- Relative humidity: 20% to 80%
- Power consumption: Max 6.8W
- Input voltage: 12V 1A

Preparing for installation

Before you install the EARU 1103 , review following information.

Item	Quantity	Supplied
Main body of EARU 110X	1	yes
DC Battery Interface Connect	1	yes
UPS	1	option
Ethernet (RJ-45), POTS(RJ-11) cable	as required	no
Optical fiber (SC/APC)	1	no

Installing the product

Mounting method

Wall mounting

Step 1: Secure the enclosure on the wall drilled as shown in following illustration with the M5 tapping screws and the spiral plastic plugs provided.

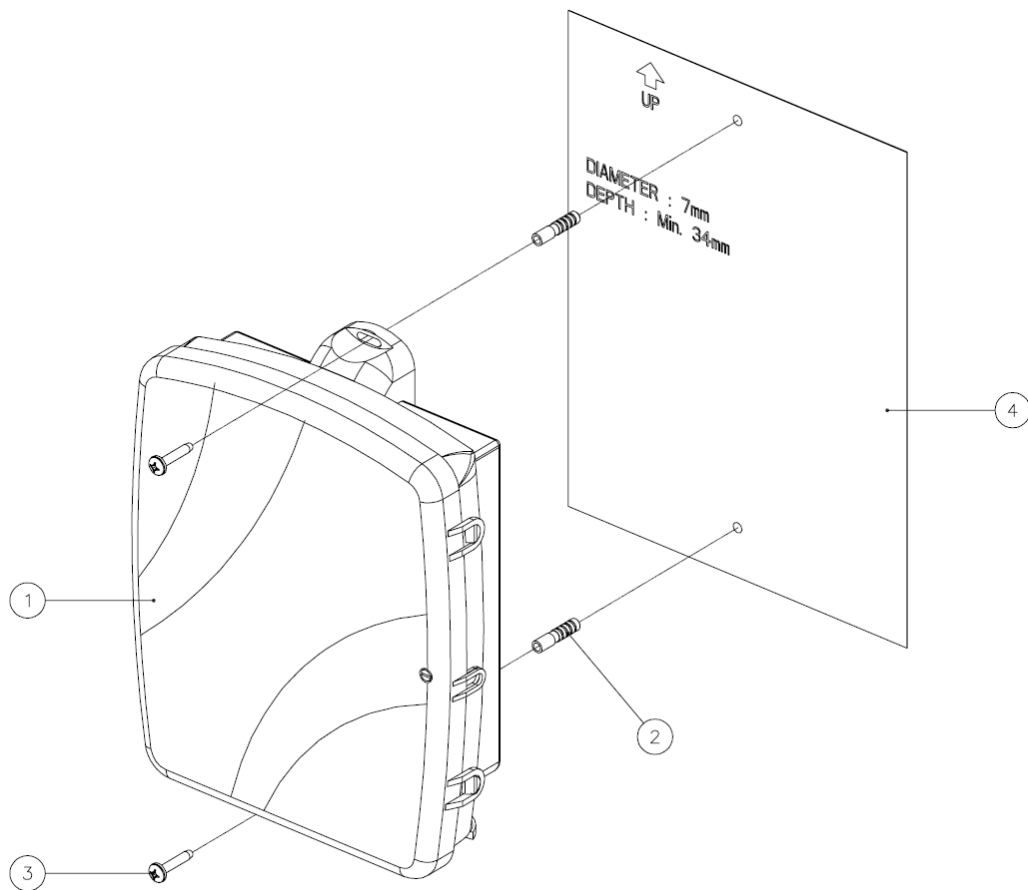

No.	Item Name	Quantity	Item Number
1	EARU1103 BODY	1	
2	SPRIAL PLASTICPLUG(BN309-7-34)	2	P04929-00
3	SCREW(BN695-4.8-38)	2	P04928-00
4	WALL MOUNTING DRILL TEMPLATE	1	N04647-00

Pole mounting

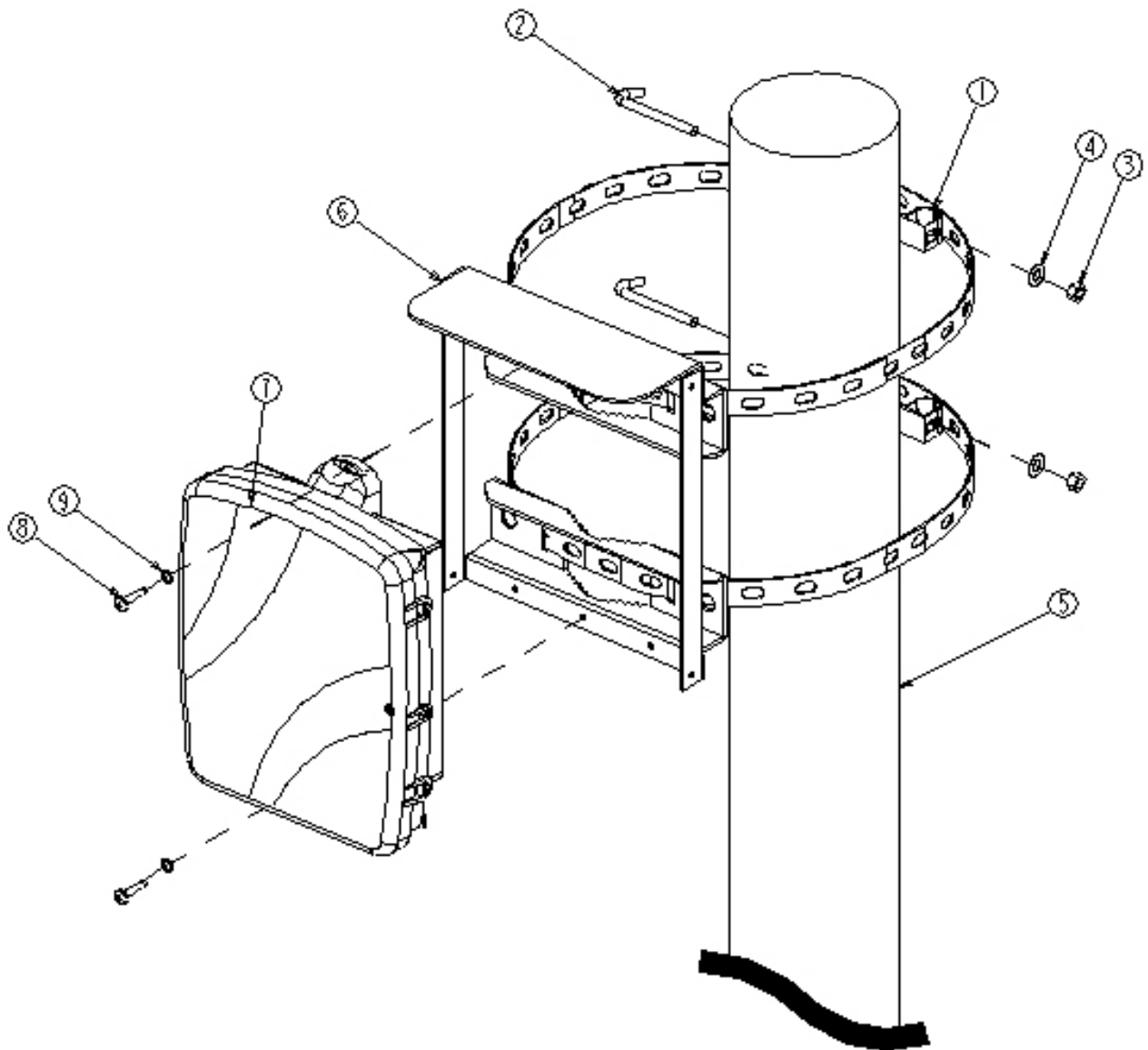

No.	Item Name	Quantity	Item Number
1	BAND	1	N05815-01
2	HOOK	1	N05815-02
3	NUT	2	N05815-03
4	WASHER	2	N05815-04
5	POLE ASSY	1	
6	POLE MOUNTING BRACKET	1	M05801-00
7	EARU1103 BODY	1	
8	SCREW(BN660-5-25)	2	P04963-00
9	WASHER(BN670-5)	2	P04962-00

Step1. Pass the two BANDS into the space back of the pole mounting bracket and then tighten the BANDS backward the pole with hand.



Step2. Tighten suitably and insert the HOOK into the hole of the other position of the BAND. Insert the rod (bolt) in the ring and tighten the NUT and WASHER (3 ~ 5N·m).



Step3. After tightening the NUT, bend the BAND at the other side.



Step4. Cut the remaining part of the BAND suitably, and then put the end of the BAND into the rod (bolt) at the the other side.



Step5. After mounting the bracket on the POLE, tighten the SCREWS on the top and bottom of the enclosure with the door open.



Grounding

STEP1: Unfasten the grounding screw on the GND TERMINAL of the EARU 1103.

(see following picture)

STEP2: Attach the 1-hole lug cable using the screw that was removed in STEP 1.

The grounding connection is suitable for terminating a #18 AWG wire.

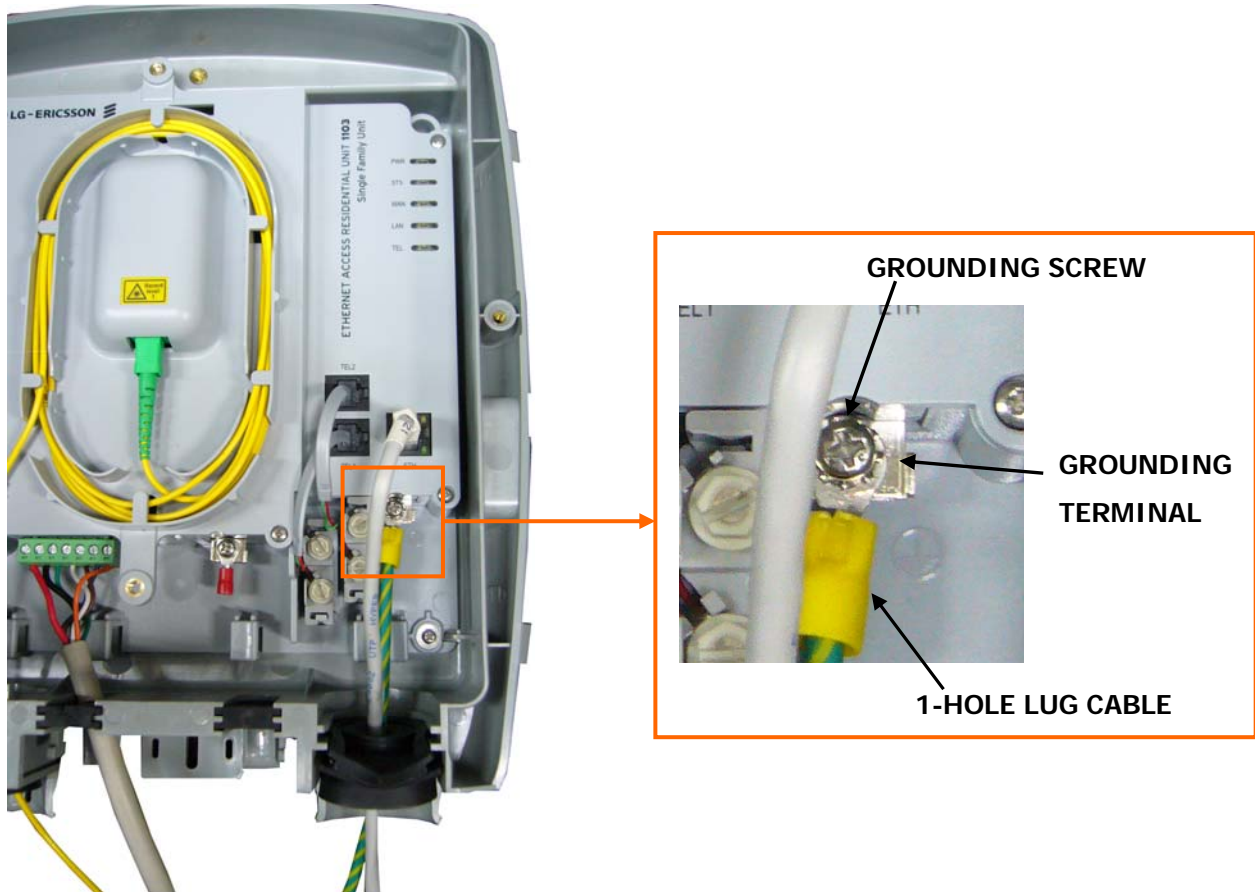

CAUTION

Earth connection is essential before connecting supply and the earthing terminal should be permanently connected to earth.

Connecting power cable

Connect the Battery plug to BATT interface from UPS.

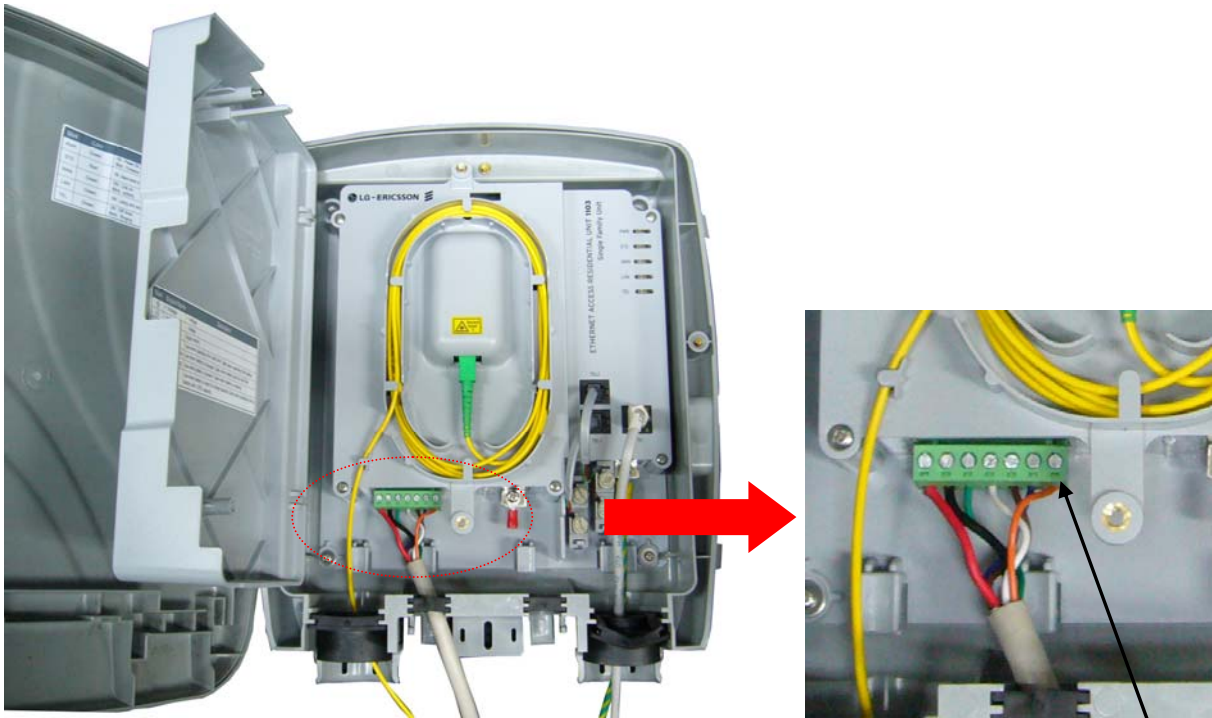

BATTERY INTERFACE

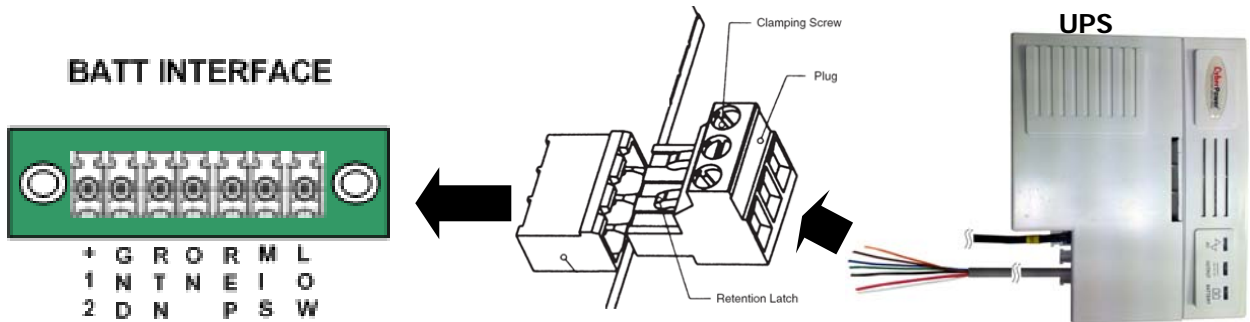

Mark	Signal Name	Description
+12V	+ Voltage	+ Voltage
GND	- Voltage	- Voltage
RTN	Signal Return	Signal Return
ON	On Battery	Low when operating from utility line. Open when operating from battery.
REP	Replace Battery	Low when battery is charged. Open when battery fails the Self Test.
MIS	Battery Missing	Low when battery is present. Open when battery is missing.
LOW	Low Battery	Low when battery is near full charge capacity. Open when operating from a battery with < 20% capacity.

Connecting optical cable

Insert the SC APC connector from RN distributor into the optical port of the EARU 1103.



CAUTION

Only SC APC connector should be used.
Other connector types will not work properly.

Connecting Ethernet cable

Connect Ethernet cables to the RJ45 Ethernet port numbered ETH1 in EARU 1103.

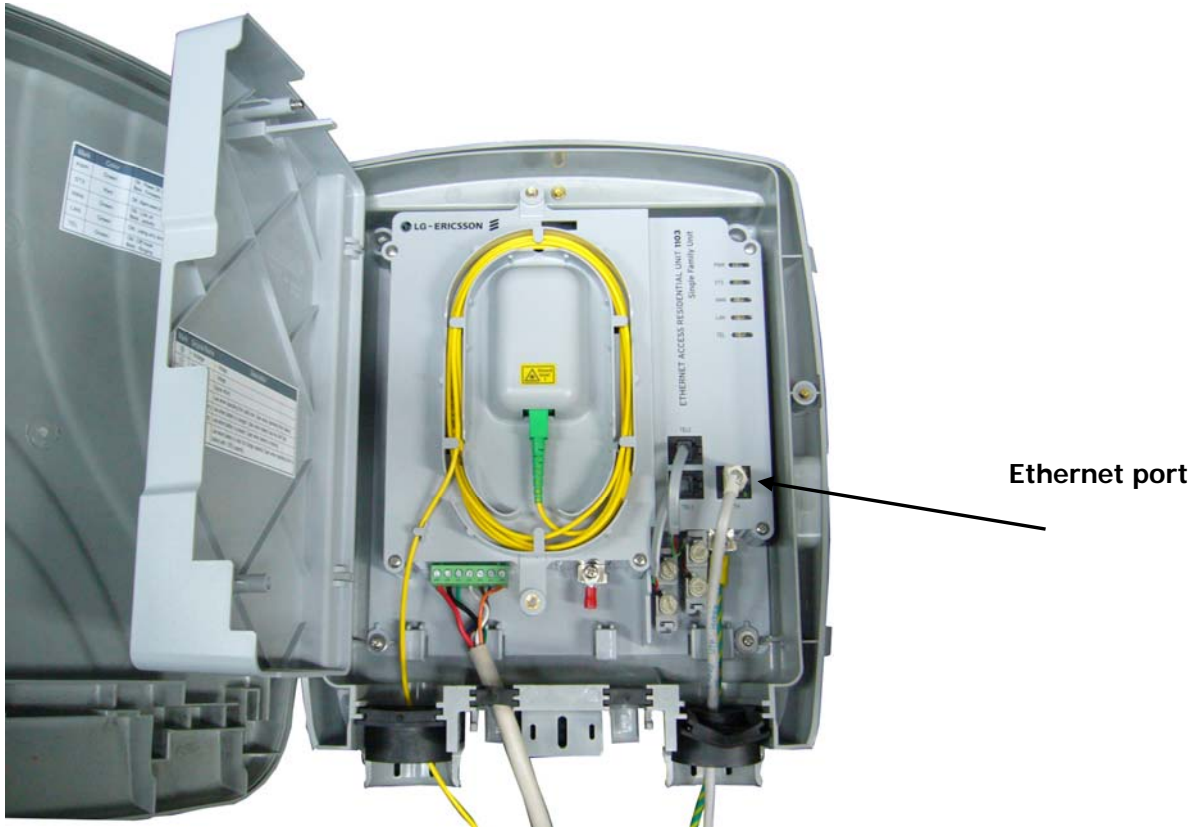

Connecting Telephone cable

Connect PCM cables from subscribers to the PCM terminals in EARU1103 referring connection state below.



CAUTION

To reduce the risk of fire, use only No.26 AWG or larger PCM cables.

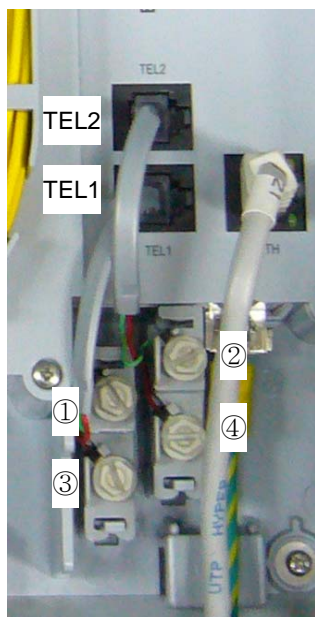
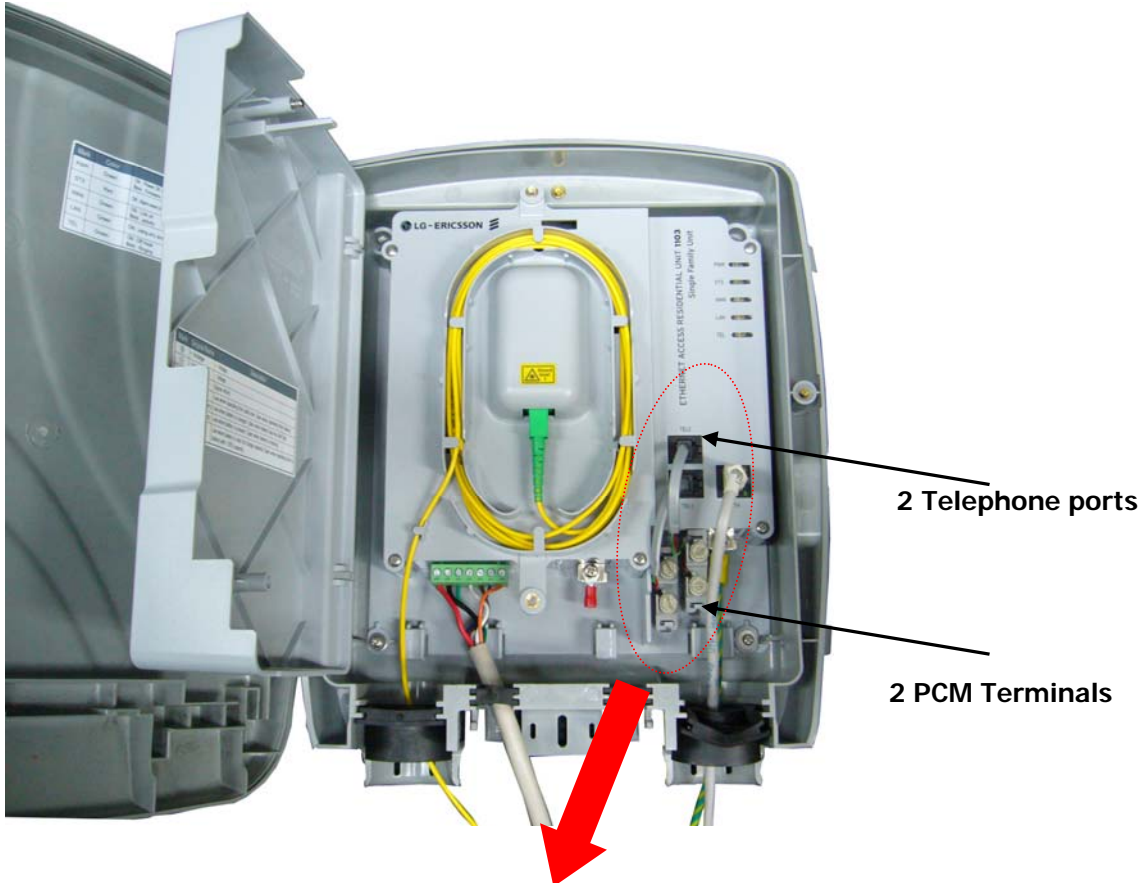

Connection state
terminal ①, ② ↔ TEL1
terminal ③, ④ ↔ TEL2

Finishing work after cabling

After cabling, do the finishing work with the silicone sealant and the cable ties.

Step1. Apply the silicone sealant to the area that the cables passing through the rubber packing to be packed fully.

Silicone sealant →



Step2. Apply the sealant to 3 areas.



Step3. Tie cables at four areas with the cable ties.

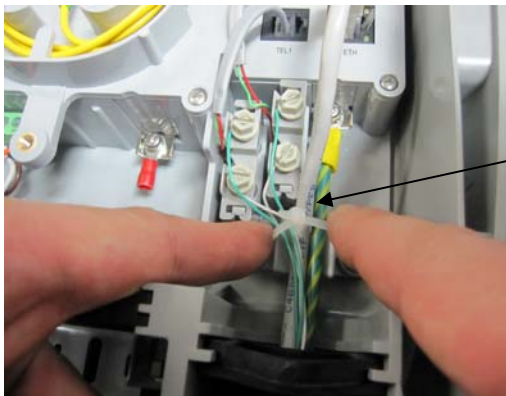

Cable tie

Checking the connection status of user devices

When EARU 1103 is power-fed, the Green and Orange LEDs should be on.

The green LED is the data indicator. It blinks when data is being transmitted or received. The Orange LED is the link indicator. It lights up with a 100Mbps connection. If there is a 10Mbps connection (a 10BaseT connection), the Orange LED is off.

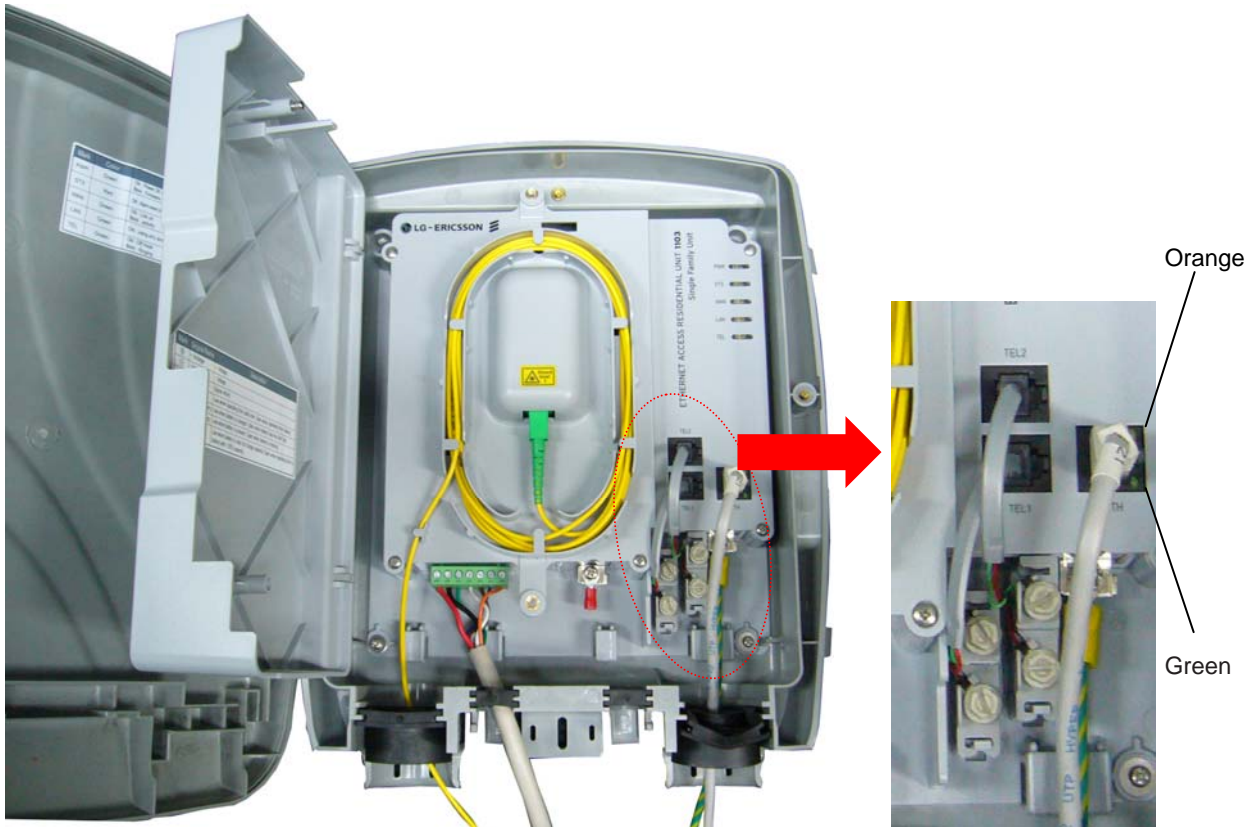

Setting EARU 1103

When you select to receive WDM-PON service, you do not have to make additional settings on the product to use it.

Using Internet

With a web browser such as the Internet Explorer on your PC, you can surf freely through the Internet.

Note

EARU 1103 does not require any access program.

Use your regular internet browser.

Open Source Software Notice

The following open source software used in this product:

- o uclibc 0.9.29
- o MIPS Linux kernel, version 2.6
- o STP bridge in kernel
- o BusyBox 1.0.0 toolset
- o iptables-1.3.8
- o Telnet server, login
- o Ftp server: bftpd 1.0.24
- o Tcpcdump and libpcap
- o dproxy: dproxy-nextgen
- o Iproute2: iproute2-2.4.7

LG-Ericsson offers to provide source codes and copies of the GPL licenses to you on CD-ROM for a charge covering the cost of performing such distribution, such as the cost of media, shipping and handling upon e-mail request to LG-Ericsson at :

opensource@lgericsson.com

This offer is valid for a period of three (3) years from the date of the distribution of this product by LG-Ericsson.

Copyright © 2010 LG-Ericsson Co., Ltd.

All Rights Reserved.

Copyright of this manual belongs to LG-Ericsson Co., Ltd.

Reproduction, distribution or revision of part or all of contents in this manual in any form without written permission of LG-Ericsson Co., Ltd. is prohibited.

The information in this manual is subject to change for the reason of function improvement, design alteration, etc. without any prior notification.

<http://www.lgericsson.com>

P/N : SM0-000-S00528 Feb/2011/Ver 1.0



