



Mobile Communications

**MDS
148-174 MHz MOBILE RADIO
COMBINATION**

TABLE OF CONTENTS

MAIN BOARD ASSEMBLY	LBI-38756
FRONT PANEL ASSEMBLY	LBI-38757
POWER AMPLIFIER ASSEMBLY	LBI-38758
SERVICE SECTION	LBI-38759



Ericsson GE Mobile Communications Inc.
Mountain View Road • Lynchburg, Virginia 24502

TABLE OF CONTENTS

	<u>Page</u>
SPECIFICATIONS	1
PACKAGE NUMBERS	2
OPTIONS	2
INTRODUCTION	2
RADIO DESCRIPTION	2
MAIN BOARD ASSEMBLY	2
FRONT PANEL ASSEMBLY	4
POWER AMPLIFIER ASSEMBLY	4
FEATURES	4
PC PROGRAMMABLE	4
EXTERNAL SPEAKER (Optional)	5
BATTERY POWER	5
EASY ACCESSIBILITY	5
SERVICE AIDS	5
DETAILED TYPE 99 OPERATION AND PROGRAMMING	5
GE TYPE 99 FORMAT	6
MOTOROLA FORMAT	6
MECHANICAL PARTS BREAKDOWN	8
MECHANICAL PARTS LIST	9
FIGURES	
Figure 1 - MDS Conventional Radio Block Diagram	3
TABLES	
Table 1 - Channel Guard Tone Frequencies	5
Table 2 - Primary and Equivalent Digital Codes (OCTAL)	5
Table 3 - Tone Groups	6
Table 4 - Tone Generator Frequencies	6
Table 5 - Motorola Type Coder Numbers	6
Table 6 - Motorola Group Call Tone Groups (TG)	7
Table 7 - Motorola Group Call Tone Groups (TG)	7

SPECIFICATIONS

GENERAL

Frequency Range	Transmit: 148-174 MHz Receive: Same as Transmit
Channel Spacing	25 kHz
Frequency Stability	±5.0 ppm
Operating Temperature Range	-30 to +60°C
Battery Voltage	13.6 volts ± 10% (meets specs) ± 20% (operational)
Radio Current Drain	OFF: 0.01 amps Rx Squelched: 0.9 amps Rx On: 1.5 amps Tx On: 10.0 amps
Size	170mm W x 216mm L x 53mm H

TRANSMITTER

Tx Two Frequency Spread	26 MHz
RF Power Output	40 watts (+ 146 dBm, Adjustable 20 to 40 watts)
Maximum Deviation	±5% kHz peak
Tx Duty Cycle	20% Intermittent (EIA)
FM Hum and Noise (EIA)	-45 dBc maximum
Audio Distortion	5% @ 300 Hz, 3% @ 1kHz, 5% @ 3kHz
RF Load Impedance	50 ohms
Audio Sensitivity	80 mV ±3 dB
Audio Frequency Response	Within + 1 , -3 dB of a 6db/octave pre-emphasis, 300-3000 Hz (EIA)
Spurious Emissions	
Conducted	-16.5 dBm max (Meets DOC & FCC)
Radiated	-13 dBm max (FCC)

RECEIVER

Receiver coverage	148-174 MHz Factory Tuned 150-168 MHz
Rx Two Freq Spread	18 MHz (No degradation)
Channel Spacing	25/30 kHz
Sensitivity (12 dB SINAD)	-117 dBm (.30 µV)

SPECIFICATIONS (Cont.)

Spurious Emissions Radiated Conducted	Meets FCC requirements -57 dBm maximum
Rx Spurious Response	70 dB minimum
Adj Ch(2-Sig) Selectivity	-75 dB max @ 30 kHz (EIA)
Intermodulation Attenuation	-75 dB minimum
Rx Modulation Acceptance	± 7 kHz minimum
Audio Distortion	2% maximum @ 0.5 Watt (EIA) 10% maximum @ 4 Watts and 1 kHz
Audio Frequency Response	Within + 2,-8 of a 6dB/octave de-emphases, 300-3000 Hz (EIA)
Rx Hum and Noise Unsquelled Squelled	-50 dB maximum -70 dB maximum
Audio Output Power	4 watts, @ <10% Distortion
Speaker Impedance	4 ohms

MDS RADIO PACKAGE NUMBERS

<u>PACKAGE NUMBER</u>	<u>DESCRIPTION</u>
TLH22	VHF 2 CHANNEL, 40 WATT
TLH28	VHF 8 CHANNEL, 40 WATT

OPTIONS

<u>OPTION NUMBER</u>	<u>DESCRIPTION</u>
MC3G	DESK TOP MIC
ANIR	1/4 WAVE, ROOF MT ANTENNA W/TNC CONNECTOR
ZM3L	EXTERNAL WEATHERPROOF SPEAKER AND CABLE
LS1F	MIL SPEC SPEAKER, 4 OHMS, 5 x 5
CD1E	SPEAKER CABLE
PD1A	NOISE FILTER KIT
SU1C	ALARM RELAY KIT
EC1A	DOC POWER SET
MAIL	DESK TOP RADIO MOUNTING WEDGE
PS1D	240 VAC-12 VDC, 13A 50/60 Hz Power Supply
PS5K	120 VAC-12 VDC, 13A 50/60 Hz Power Supply

INTRODUCTION

The Ericsson GE Conventional MDS VHF Radio is a rugged two-way FM mobile radio which operates in the 148-174 MHz frequency band. The MDS is a wide band synthesized radio utilizing microcomputer technology to provide reliable high quality simplex two-way mobile communications. Its transmitter output power level is 40 watts over the wide bandwidth of each split. The receiver has an allowable 12 MHz maximum receive channel separation. There are two versions available, a 2-channel and an 8-channel. The basic radio package includes the following features:

- Microprocessor Control
- Synthesized RF Channel selection (frequency control)
- 7-Segment LED Channel Display
- Multi-tone Channel Guard (CTCSS) Encode/Decode
- Multi-code Digital Channel Guard (DCG) Encode/Decode
- Automatic Hook Switch Channel Guard Disable
- Channel Activity Sensing (CAS)
- Carrier Control Timer (CCT)
- 5 ppm frequency stability
- Type 99 Tone Decode
- Field Programmable with PC
- Fixed Squelch, threshold programmable
- Internal 4-watt Speaker, with volume control
- Front Mounted Microphone Connector
- Rear Mounted Antenna TNC Connector
- Rear entry power connections
- ANI Encode

The small size of the MDS radio makes it ideal for front mounting in conventional vehicles. The radio is operated with a simple hand held microphone in combination with the following operating controls, all located on the front panel:

- Power ON/OFF Switch
- Channel UP/DOWN Selector
- Volume UP/DOWN Control
- Monitor Switch for Channel Guard Disable
- Type 99 Tone RESET Switch, to reset the tone decoder.

Refer to the Operator's Manual LBI-38651 for a complete description of the operating procedures.

RADIO DESCRIPTION**MAIN BOARD ASSEMBLY**

A sturdy aluminum casting houses the Main Board Assembly N29/85154001920. There is complete accessibility to the Main Board with the radio's top and bottom covers removed. The Main Board contains the following circuits:

- Microprocessor and associated Logic
- Frequency Synthesizer
- Transmitter Exciter
- Receiver
- Audio Processing (for both transmit and receive paths)
- Tone and Squelch Processing (for both transmit and receive paths)
- Voltage Regulators

Logic Circuitry

The radio's logic circuitry includes the 80C535 microprocessor with associated EPROM and Electrically Erasable PROM (EEPROM) memory and latch circuitry. The Microprocessor controls the functions of the transmitter, the receiver, the inputs from the operator and the outputs to the operator.

Synthesizer

A programmable Synthesizer generates both transmit and receive operating frequencies. It includes a synthesizer chip, a dual modulus counter, a temperature compensated reference oscillator (TCXO) and a voltage controlled oscillator (VCO); all part of an operating phase lock loop, with its requisite loop filter.

Transmitter

The radio transmitter includes the Synthesizer's modulated VCO and the fixed tuned exciter amplifiers. The exciter amplifiers are wideband, covering the VHF band without retuning. The exciter output is fed to the Power Amplifier Board through a coax cable. The exciter provides 35 dB of gain to drive the Power Amplifier with 2 watts. The transmitter output level at the antenna connector is factory set for a rated output power of 40 watts. The power control circuit detects the power output of the Power Amplifier. Using the error signal, the power control circuit varies the DC supply voltage to the first stage of the exciter. This will hold the transmitter output level constant.

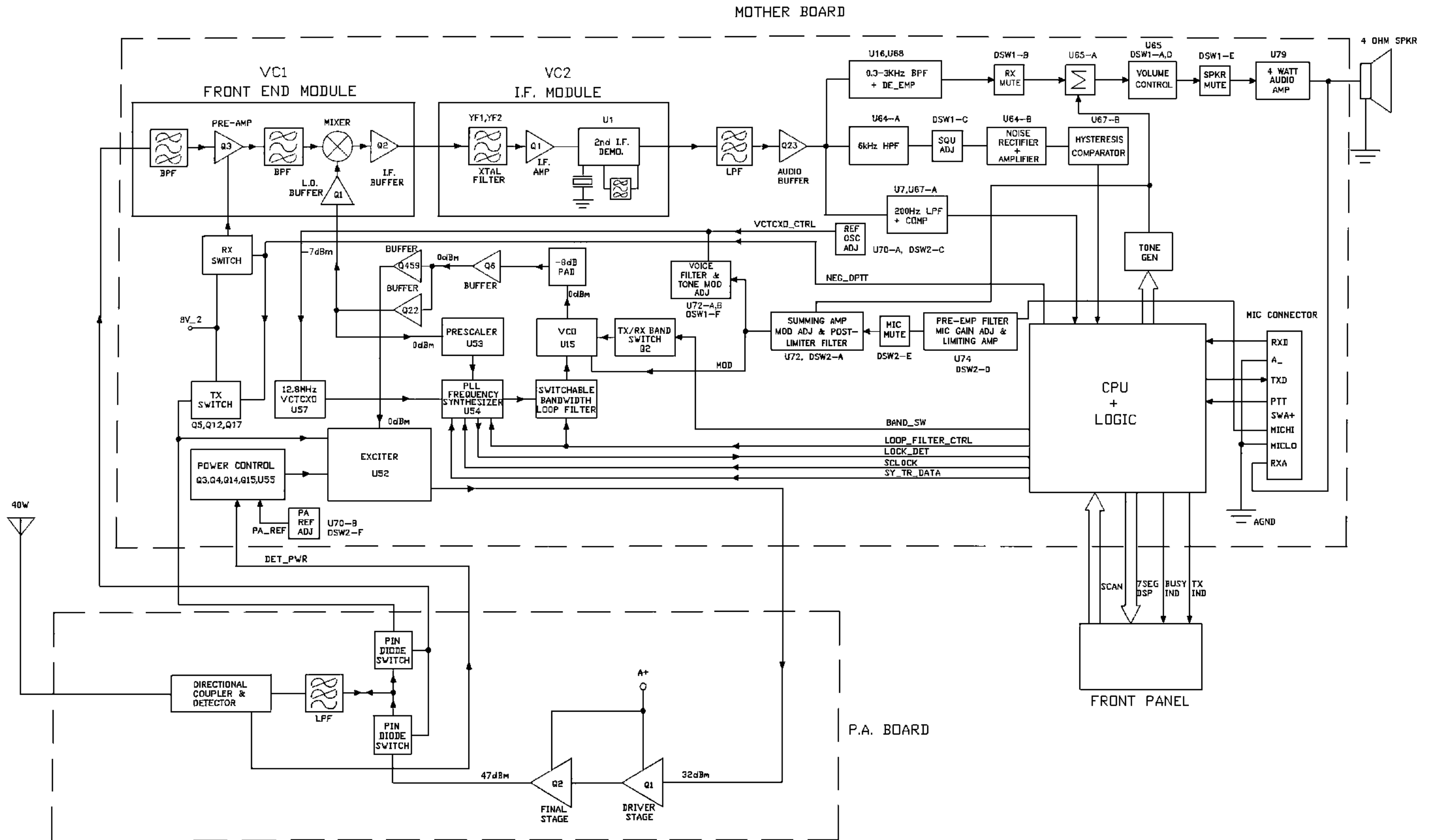

Figure 1 - MDS Conventional Radio Block Diagram

Receiver

The RF front end of the receiver includes the PIN diode T/R switch, the tuned bandpass preselector filters, and the low noise RF amplifier. The filters have a 12 MHz bandwidth, and are factory tuned for receiving in the 150-162 MHz bandwidth. Refer to the Service Section LBI-38759 for retuning to a different frequency. The first mixer (with its low side injection from the VCO) generates a 45.000 MHz IF signal which is filtered with monolithic crystal filters having a 15 kHz bandwidth. A 455 kHz low IF circuit module contains the second local oscillator, the second mixer with low side injection, external ceramic filters, an external 44.545 MHz crystal for the oscillator and the FM quadrature detector circuit.

Transmit Audio Processing

In the transmit audio path, the audio from the microphone is passed through a 3 kHz low pass filter, preemphasized and hard limited for a maximum modulation peak deviation of 4.5 kHz. A MIC Mute switch is controlled by the logic as appropriate for tone or voice modulation of the transmitter. Channel Guard tones and the A.N.I. signal from the microprocessor are summed into the audio path before the gain control. Next, a 3 kHz post limiter low pass filter attenuates frequencies above 20 kHz by more than 54 dB before passing the audio signal on to the modulation input of the VCO.

Receive Audio Processing

Audio from the demodulator enters the voice path through a 300 Hz high pass filter, followed by a 3 kHz low pass filter. A "Receive Mute" switch is provided so the voice signal can be muted by the microprocessor when it sums its Alert tones into the path. The "Receive Mute" switch attenuates the voice audio by 50 dB when the Alert tones are summed into the path. The path is completed with a gain control, and a logic controlled switch for speaker muting while transmitting. The audio power amplifier which delivers 4 watts to the speaker is connected on the Main Board, but is mounted on the aluminum chassis for heat sinking.

Tone And Squelch Processing

The Channel Guard path includes a 220 Hz low pass filter for passing the received Channel Guard tones without audio. A tone limiter insures a 5 volt pp maximum input tone level to the microprocessor.

In the Squelch path, noise above the audio voice frequencies is filtered through a 6 kHz high pass filter; amplified and then limited. A DC detector generates a DC voltage rep-

resenting the amplitude of the noise. This DC voltage is applied to a comparator. The out-put from the comparator is fed to the microprocessor. The microprocessor squelches the receiver under conditions of high noise and absence of carrier.

Since the frequencies of Type 99 tones fall in the voice band, they are passed through the 300 Hz high pass filter in the voice path. Next, the tones are shunted through a closing switch and passed into the tone path in front of the tone limiter. The tone limiter passes the tones on to the tone detector port of the microprocessor.

Voltage Regulator Circuitry

The battery voltage (IGN A +) enters the radio at J11 on the Power Amplifier Board. From the PA Board IGN A + is routed directly to the Main Board where it is filtered and passed through a relay as A + _SW. A + _SW is fed to the regulator circuits which provide a regulated 8, 5 and 2 volts to the appropriate circuits throughout the radio. A + _SW is also fed to the Audio Power Amplifier circuits.

FRONT PANEL ASSEMBLY

The Front Panel Assembly (N29/85154000950) houses the Front Panel Board, the internal 4-watt speaker, and all control switches and indicators for the radio. The panel is made of highly durable plastic with rounded corners and recessed controls and indicators for passenger safety. The Front Panel Board mounts on back of the Front Panel. The following display elements are on the front panel:

- Channel Number Display, 7-segment LED with numbers 1-8
- Transmit Light, lights when radio is transmitting
- Busy Light, ON when channel is busy

See the Operator's Manual LBI-38659, for a detailed description of the indicators, controls and operation of the radio.

The microphone connector is an RJ-11 type, female connector mounted to the Main Board but located on the front panel of the radio. A strain relief is provided to secure and protect the microphone connector. A microphone Hook Switch with magnetic sensing is provided with the radio to be mounted externally on the dashboard of the vehicle. Removing the microphone from the Hook Switch disables the Channel Guard, enabling the operator to monitor the channel before sending a message.

POWER AMPLIFIER ASSEMBLY

The Power Amplifier Assembly (N29/85154000930) contains the Power Amplifier Board mounted to an aluminum die-cast heatsink. The PA Board contains the RF Power Amplifier, the RF output LP harmonic filter, the PIN diode T/R switch, and a stripline directional coupler for power output sensing.

The RF Power Amplifier is driven by the output of the exciter on the Main Board, which is connected by coax to the PA Board. The PA Board amplifies the output from the Main Board to a level of 40 watts over the frequency range of 148-174 MHz. The output of the PIN diode T/R switch is coaxially connected to the receiver front end circuitry on the Main Board. The T/R switch has a separate connection to the antenna jack. The IGN_A + External Speaker and External Alarm lines connect to the Power Amplifier Board at J11.

FEATURES

PC PROGRAMMABLE

The entire personality of the radio is programmed into the radio using an IBM or IBM compatible personal computer and the following equipment:

- Serial Programming Interface Module TQ-3310
- MDS Programming Cable TQ-3361
- MDS Conventional Programming Software TQ-3363

The interface module is connected between a serial port on the computer and the RJ-11 microphone connector on the Front Panel of the radio. An RS-232 cable connects the serial port to the Interface Module. The Programming Cable (TQ-3361) is connected from the Interface module to the RJ-11 microphone connector on the front of the radio. Refer to TQ-3363 for a complete set of instructions on how to program the MDS Conventional radio.

Tracking Data

The test handset is used to make operational circuit adjustments in the radio using digitally controlled potentiometers. The resulting "Tracking Data" is stored in the EEPROM personality of the radio. A utility in the PC Programming software can be used to read the Tracking Data. All programming is done through the microphone connector on the Front Panel of the radio, without the need of opening the radio package. The Tracking Data adjustments made with the test handset include the following:

- Reference voltage for Transmit RF power output level

- Voltage for VCTCXO frequency adjustment
- Modulation deviation adjustment for VCO
- Channel Guard modulation deviation adjustment
- Microphone gain adjustment, 2 pots in voice path
- Other filter adjusting pots

Programmable Features/Options

Squelch Tail Elimination

Squelch Tail Elimination (STE) is used with both tone and digital Channel Guard to shorten the noise burst between receiving a call and muting the receiver audio path. This is commonly referred to as reducing squelch tails. The STE burst is transmitted when the microphone PTT is released. The receiving radio decodes the burst and mutes the receiver audio for 250 ms. The duration of this mute time includes time for the end of transmission plus that of the squelch tail. The radio looks for STE on the received signal when the microphone is either ON or OFF-hook. The STE is enabled for transmit and/or receive by PC programming the radio's personality.

Carrier Control Timer

The Carrier Control Timer (CCT) turns off the transmitter after the microphone push-to-talk (PTT) switch has been keyed for a pre-programmed time period. A pulsing alert tone will warn the operator to unkey and then rekey the PTT to continue the transmission. The timer can be programmed to time out for 15 to 225 seconds in 15 second increments. The CCT will be the same for all channels in the personality.

Type 99 Decode

Type 99 2-tone sequential selective calling is programmable on a per channel basis, with the radio enabled to decode only. On a channel where Type 99 has not been selected in programming, the Type 99 tone decoder is disabled. The Type 99 selective calling option operates in either Type 99 Select Mode or Type 99 Monitor Mode. The default mode can be designated in programming. See the section **DETAILED TYPE 99 OPERATION AND PROGRAMMING**, on page 11, for more detailed information on Type 99 Decode.

Automatic Number Identification (A.N.I.)

As an option, one ID number per radio is programmed on a per channel basis. The microprocessor generates the special 1600 Hz A.N.I signal which is coded with a 4-bit phase reversing code. It is sent at a 400 baud rate as part of the handshaking preamble to a repeater just after PTT has been pressed, or alternatively just after release of the PTT key. A.N.I. is re-

ceived and optionally de modulated by the repeater as part of the system protocol when so installed.

Receive-Only Operation

Channels can be programmed to receive-only operation. Channels cannot be programmed for Transmit-only operation.

Busy Channel Lock Out

With Busy Channel Lock Out programmed, the radio cannot transmit on a channel already busy. If the channel is busy, fast pulsing beeps will sound (without stopping), until the PTT switch is released. The radio must be programmed for, and receiving, the correct Channel Guard. The combination of Channel Guard and Busy Channel Lock Out prevents the user from talking on a channel that is already in use (busy).

When the Busy Channel Lock Out option is enabled without programmed Channel Guard, the user is prevented from transmitting over a channel until there is no carrier present in the channel.

Minimum Volume Level

The Front Panel VOLUME controls permit adjustment of the audio level. Minimum levels are programmable. This feature prevents missed calls due to a low volume level.

Power Level

Incremental transmitter power level change can be programmed to permit setting the output power to rated value. The selected power level will be used for all channels.

Channel Guard

Channel Guard provides a means of restricting calls to specific radios through the use of a continuous tone coded squelch system (CTCSS), or a multi-code digital squelch system (DCG). Tone frequencies range from 67 Hz to 210.7 Hz. There are 83 standard programmable digital codes.

The Channel Guard tone frequencies and codes are software programmable. Both tone frequencies and digital codes may be mixed on each channel. The frequencies and codes are shown in Tables 1 and 2. A Channel Number display that does not flash, indicates that Channel Guard is enabled, or that Channel Guard is not programmed. A flashing Channel Number indicates that Channel Guard is programmed and disabled.

EXTERNAL SPEAKER (Optional)

The power connector provides a place to connect an external speaker. The internal speaker must be disconnected when an external speaker is used.

BATTERY POWER

The vehicle 12 volt battery with negative ground is all that is required for operation of the radio. A cable connects the battery to a male connector mounted on the back of the radio. The radio can also be powered with the vehicle ignition switch.

EASY ACCESSIBILITY

The radio circuitry is mostly contained on a single Main Board, with the exception of the PA Board and the Front Panel Board. Access to the Main Board and the inside of the radio is easy with the removal of the top and bottom covers with two screws each. Then the few adjustment controls (most are adjusted with PC programming) can be easily reached. Four more screws will permit removal of the front panel, giving access to the Front Panel Board along with the switch and indicator circuitry.

SERVICE AIDS

- Test Handset Kit (SPK9024), includes Handset (19A706965P3) and Coiled Cord (19D901619P2)
- Test Adapter Box (TQ0618)
- Programming Cable (TQ3361)
- PC Programming Adapter (TQ3310)
- Power Contact Extraction Tool (458994-2)

DETAILED TYPE 99 OPERATION AND PROGRAMMING

The original Type 99 programming provides individual, group and super group call decode. The motorola format two-tone sequential signaling schemes can also be decoded.

The MDS Conventional radio can be PC programmed with up to two separate tables of tones. Either the GE Type 99 format or the Motorola format can be assigned to each tone table. The tone decoder (Individual, Group and Quick Call for the Motorola format) can be enabled individually for each channel. Once enabled, one of the two tone tables can be selected for each channel.

The Group Call format allows communication with all radios within a subgroup. The Super Group Call in GE tone systems) or Quick-Call (in Motorola tone systems) allows communications between all radios in a system.

The MDS Conventional radio can operate in either the Type 99 Select Mode or the Type 99 Monitor Mode. In the Type 99 Select Mode the speaker audio remains muted until the user's own Type 99 code is decoded, unmuting the audio and permitting receipt of the message. At this time an audible alert sounds and an "A" appears in the display. The "A" will remain displayed (instead of the selected channel number) until the RESET button is pressed or the transmitter is keyed.

Table 1 - Channel Guard Tone Frequencies

Standard Tone Frequencies in Hertz						
67.0	82.5	97.4	114.8	136.5	162.2	192.8
71.9	85.4	100.0	118.8	141.3	167.9	203.5
74.4	88.5	103.5	123.0	146.2	173.8	210.7
77.0	91.5	107.2	127.3	151.4	179.9	
79.7	94.8	110.9	131.8	156.7	186.2	

Table 2 - Primary and Equivalent Digital Codes (OCTAL)

PRIMARY CODE	EQUIVALENT CODE	PRIMARY CODE	EQUIVALENT CODE	PRIMARY CODE	EQUIVALENT CODE
023	340,766	132	605,634,714	237	464,642,772
025		133	413,620	243	267,342
026	566	134	273	245	370,554
031	374,643	135	205,610	246	542,653
032		136	502,712	252	661
036	137	142	174,270	254	314,612,706
037	560,627	143	333	255	425
043	355	144	466,666	262	316,431,730
047	375,707	145	525	266	655
051	520,771	147	303,306,761	271	427,510,762
053		150	256,703	274	652
054	405,675	152	366,415	276	326,432
056	465,656	153	606,630	307	362,565
057	172	155	233,660	311	330,456,561
060	116,737	156	517,741	312	515,663,743
065	301	157	322,503	315	321,673
066	734	161	345,532	317	546,614,751
067	516,720	162	416,553	324	343,570
071	603,717,746	163	460,607,654	325	550,626
072	470,701	164	207,732	331	372,507
073	640	165	354	332	433,552
074	360,721	171	265,426	344	471,664,715
075	501,624	176	244,417	346	616,635,724
076	203,754	212	253	351	353,435
104	226,557	213	263,736	356	521
107	365	217	371,453,530	363	436,443,444,662
114	327,615	222	445,457,575	446	467,511,672
115	534,674	223	350,475,750	447	473,474,731,744
117	411,756	224	313,506,574	452	524,765
122	535	225	536	454	513,545,564
123	632,657	227	261,567	455	533,551
125	173	231	504,631,636,745	462	472,623,725
127	417,441,711	234	423,563,621,713	523	647,726
130	364,641	235	611,671,723	526	562,645
131	572,702	236	251,704,742		

In the Type 99 Monitor Mode the receive audio remains unmuted permitting the user to monitor all activity on the channel. When the user's own Type 99 tones are decoded, a beep sounds and an "A" will be displayed, calling his attention to his own call now on the channel.

Toggling the RESET button allows the user to choose either the Type 99 Select Mode or Type 99 Monitor Mode of receiving.

GE TYPE 99 FORMAT

Tone frequencies in the GE tone system fall within the range of 517.5 to 997.5 Hz.

In the GE tone format, the first tone may be from tone group A (for Individual or Group calls) or from tone group C (for Super Group calls). The second tone may be from tone group B (for Individual calls) or from tone group D (for Group and Super Group calls).

The GE tone format is illustrated below:

INDIVIDUAL CALL FORMAT

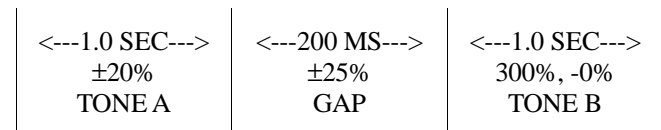

GROUP CALL FORMAT

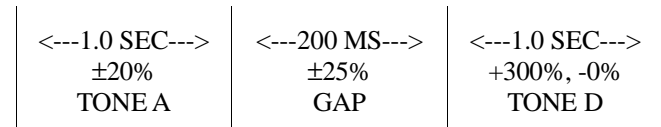

SUPER GROUP CALL FORMAT

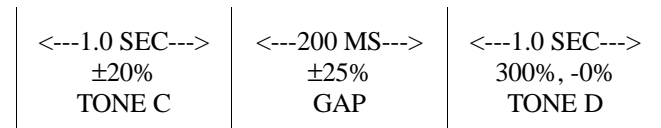

For example, assume the paging number to be 123. The first digit of the paging number is a 1. Look in Table 3 and read down the column labeled "100's Digit" to a 1. Read horizontally across the column labeled "10's Digit". The tone group is **B**. The second digit of the paging number is a 2. The tone number is **B2**. Look in Table 4 and down the column labeled "Tone Designator" to find B2. Read horizontally across the column labeled "Tone Frequency". The first tone frequency is 787.5 Hz.

To determine the second tone frequency look in Table 3 and as before, find the first digit of the paging number (1).

Table 3 - Tone Groups

100's Digit	10's Digit	1's Digit
	For First Tone	For Second Tone
0	A	A
1	B	A
2	B	B
3	A	B
4	C	C
5	C	A
6	C	B
7	A	C
8	B	C
9	NOT USED	

Table 4 - Tone Generator Frequencies

STONE GROUP	STONE DESIGNATOR	STONE FREQUENCY
A	A0	682.5 Hz
	A1	592.5 Hz
	A2	757.5 Hz
	A3	802.5 Hz
	A4	847.5 Hz
	A5	892.5 Hz
	A6	937.5 Hz
	A7	547.5 Hz
	A8	727.5 Hz
	A9	637.5 Hz
B	B0	652.5 Hz
	B1	607.5 Hz
	B2	787.5 Hz
	B3	832.5 Hz
	B4	877.5 Hz
	B5	922.5 Hz
	B6	967.5 Hz
	B7	517.5 Hz
	B8	562.5 Hz
	B9	697.5 Hz
C	C0	667.5 Hz
	C1	712.5 Hz
	C2	772.5 Hz
	C3	817.5 Hz
	C4	862.5 Hz
	C5	907.5 Hz
	C6	952.5 Hz
	C7	532.5 Hz
	C8	577.5 Hz
	C9	622.5 Hz
DIAGONAL TONE		742.5 Hz

The second tone group is **A**. The third digit of the paging number is a 3 and the tone Designator is **A3**. In Table 4 read down the column labeled "Tone Designator" and find **A3**. Read horizontally across the column labeled "Tone Frequency". The second tone frequency is 802.5 Hz. For different paging numbers, locate the first digit in the "100's Digit" column and determine the tone frequencies as described in the example.

Tone D is the diagonal tone used (in GE tone systems only) when the first and second tone frequencies are the same. The standard frequency for **Tone D** is 742.5 Hz, but may be programmed with any tone frequency.

MOTOROLA FORMAT

Tone frequencies in the Motorola tone system are within the range of 288.5 to 1433.4 Hz. In the Motorola tone format, the first tone may be one of three tones: **A** for Individual Call, **B** for Quick Call and **C** for Group Call. The second or final tone is **B** in all cases.

NOTE

The MDS radio is able to recognize the **A**, **B**, and **C** tones. Individual, Group and Quick Call formats may be used simultaneously.

The Motorola tone format is illustrated as follows:

INDIVIDUAL CALL FORMAT

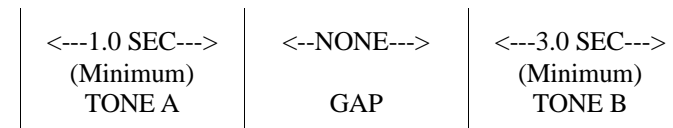

GROUP CALL FORMAT

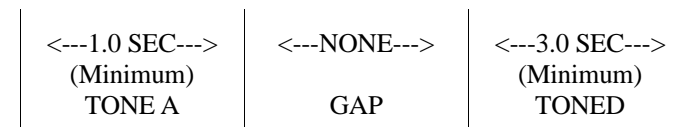

SUPER GROUP CALL FORMAT

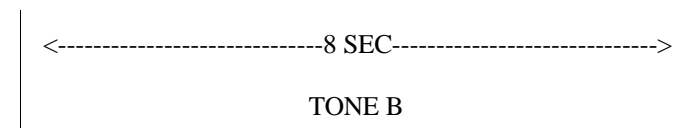

Individual Call

Tables 5 and 6 may also be used to determine the tone frequencies. The first digit of the code determines the tone group used in the code (see Table 5). Then Table 6 is used to determine the actual tone frequencies. For a code of 124, the tone groups used are shown in Table 5. Tone A and Tone B are both located in tone group 1 and Tone B is tone number 4. Refer to the following examples for additional information.

Table 5 - Motorola Type Coder Numbers

First Digit of Code	Group from Which Tone A Is Selected	Group from Which tone B Is Selected
1	1	1
2	2	2
3	1	2
4	4	4
5	5	5
6	2	1
7	4	5
8	5	4
9	2	4
0	4	2
A	3	3

Example 1 - Code 098:

The digit "0" in Table 5 (First Digit of Code) shows that **Tone A** is in Tone Group 4 and **Tone B** is in Tone Group 2 (see Table 6).

Tone number 9 in Tone Group 4 is 524.6 Hz.

Tone number 8 in Tone Group 2 is 879.0 Hz.

Example 2 - Code 265:

The digit "2" in Table 5 shows that both **Tone A** and **Tone B** are both in Tone Group 2.

Tone number 6 is 788.5 Hz.

Tone number 5 is 746.8 Hz.

Group Call (Quick-Call Format)

In Group Call applications, the Tone Group is determined by Table 7, while the frequency is determined by Table 6. Refer to the following examples.

NOTE

Group Call code numbers range from 00 to 99. However, there are several Group Calls with the same Tone B frequency. This limits the total number of Group Calls to 40.

The digit "0" in Table 5 shows that Tone B is in Tone Group 2 along with 20 to 29 and 30 to 39. Tone number 7 in Tone Group 2 is 832.5 Hz (see Table 6).

Example 2 - Group Call 98 (also code 48 and 88):

The digit "9" in Table 5 shows that **Tone B** is in Tone Group 4 along with 40 to 49 and 80 to 89. Tone number 8 in Tone Group 4 is 496.8 Hz.

Example 1 - Group Call Code 07 (also code 27 and 37):

Table 6 - Motorola Group Call Tone Groups (TG)

Tone No.	Tone Group 1	Tone Group 2	Tone Group 3	Tone Group 4	Tone Group 5	Tone Group 6
1	349.0 Hz	600.9 Hz	288.5 Hz	339.6 Hz	584.8 Hz	1153.4 Hz
2	368.5 Hz	634.5 Hz	296.5 Hz	358.6 Hz	617.4 Hz	1185.2 Hz
3	389.0 Hz	669.9 Hz	304.7 Hz	378.6 Hz	651.9 Hz	1217.8 Hz
4	410.8 Hz	707.3 Hz	313.0 Hz	399.8 Hz	688.3 Hz	1251.4 Hz
5	433.7 Hz	746.8 Hz	321.7 Hz	422.1 Hz	726.8 Hz	1285.8 Hz
6	457.9 Hz	788.5 Hz	330.4 Hz	445.7 Hz	767.4 Hz	1321.2 Hz
7	483.5 Hz	832.5 Hz	339.6 Hz	470.5 Hz	810.2 Hz	1357.6 Hz
8	510.5 Hz	879.0 Hz	348.8 Hz	496.8 Hz	855.5 Hz	1395.0 Hz
9	539.0 Hz	928.1 Hz	358.6 Hz	524.6 Hz	903.2 Hz	1433.4 Hz
0	330.5 Hz	569.1 Hz	1092.4 Hz	321.7 Hz	553.9 Hz	1122.5 Hz

Table 7 - Motorola Group Call Tone Groups (TG)

GROUP CALL CODE NUMBER	TONE GROUP (TONE B)
00-09	TG2
10-19	TG1
20-29	TG2
30-39	TG2
40-49	TG4
50-59	TG5
60-69	TG1
70-79	TG5
80-89	TG4
90-99	TG4

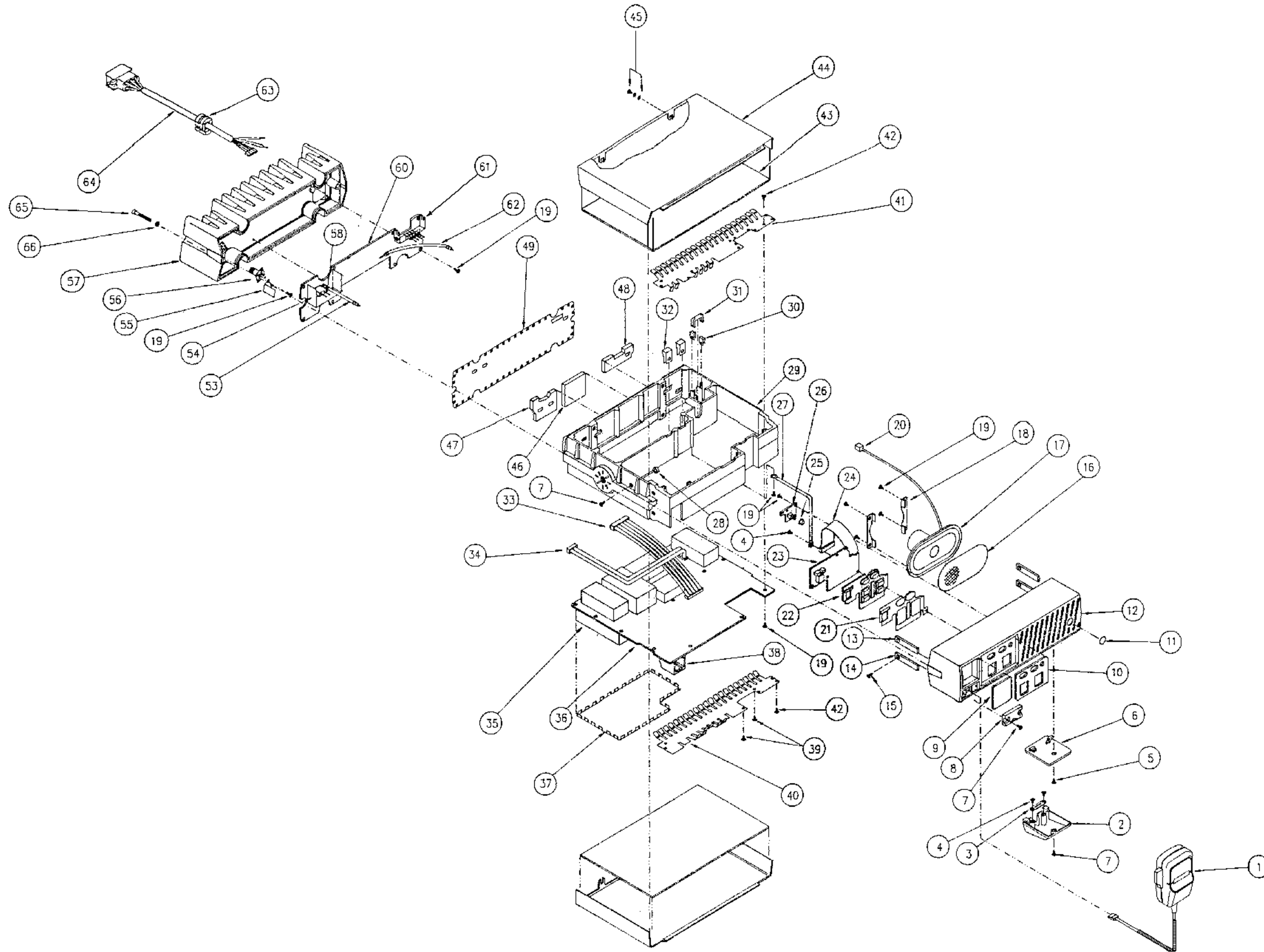

MECHANICAL PARTS LIST
MDS CONVENTIONAL (VHF)
ISSUE 1

SYMBOL	PART NO.	DESCRIPTION
		NOTE: ONLY ITEMS WITH A PART NUMBER WILL BE AVAILABLE AT SERVICE PARTS. ITEMS WITHOUT A PART NUMBER ARE LISTED FOR REFERENCE ONLY AND WILL NOT BE STOCKED AT SERVICE PARTS
1	19B801398F11	Microphone assembly.
2		Data cable, strain relief.
3		Strain relief plate.
4		Taprite screw : M2.6 x 6.
5		Machine screw: M2.6 x 6.
6		Cover, data port.
7	N29/39120403052	Machine screw: M2.6 x 12.
8	N29/18354000211	Mic cable strain relief.
9	N29/18354000280	Display lens.
10	N29/18354000422	Control Panel.
11	N29/18654000010	Name Plate.
12	N29/18354000272	Front Panel.
13		Mounting Tab - A.
14		Mounting Tab - B.
15		Machine screw M3 x 8.
16		Speaker felt paper.
17	N29/09154000010	Loudspeaker, 4 watt.
18		Speaker retainer.
19		Screw, Taprite: M2.6 x 8.
20	N29/85154001880	Speaker cable assembly.
21		Grounding foil.
22	N29/18354000281	Key pad.
23	N29/85154000950	Front panel assembly.
24	N29/85101700920	Flat ribbon cable assembly, 16-wire (W7).
25	N29/28154000010	Button, power switch.
26		Auxiliary PCB, Front Panel.
27		Grounding cable.
28		Nut M2.6.
29		Chassis frame.
30		Clip.
31		Clip.
32		Clip.
33	N29/85154001681	Cable assembly, 4-wire (W4).
34	N29/85154001671	Cable assembly, 2-wire (W3).
35		Shield can.
36	N29/85154000920	Main PCB.
37		Cover, shield can.
38	N28/14854000020	Modular mic jack (J5).
39		Screw, countersink taprite: M2 x 5.
40		Contact shield, cavity side.
41		Contact shield, ore side.
42		Screw Taprite: M2 x 6.
43		Shielding pad.
44	N29/40354000252	Top (or bottom) cover.
45		Screw M2.8 x 8, plain washer, and spring washer assembly.
46		Foam pad, harmonic shield.
47		Foam pad, 2 way header.
48		Foam pad, 4 way header.
49		Shield, heatsink and frame.
50		Rectangular washer.
53	N29/85154000702	Coaxial cable assembly, 80mm (W2).
54		Partition shield.
55		Grounding plate, TNC connector.

* COMPONENTS ADDED, DELETED OR CHANGED BY PRODUCTION CHANGES

SYMBOL	PART NO.	DESCRIPTION
56	N29/14900900021	Antenna TNC connector.
57		Heat sink.
59		2 way header and shielding shell.
60	N29/85154000930	Power Amplifier Board assembly
61		Shielding bracket and 4 way header.
62	N29/85154002210	Coaxial cable assembly, 100mm (W1).
63	N29/18454000020	Power cable strain relief.
64	N29/85154001860	Power cable assembly (W6).
65		Hex Screw, socket head M4 x 30.
66		Spring washer M4.