

When properly located, installed and maintained, it is designed to give early warning of fires by producing alarm sounds. It can provide precious time for you and your family to escape before a fire spreads.

Smoke detection triggers:

- A loud piezoelectric buzzer (85 dBA at 3 meters),
- Turns-on red LEDs on the device, and
- Sends an RF signal to the We.R™ system Central Control Unit.

The Smoke Detector detects smoke that enters its chamber. It does not detect gas, heat or flame.

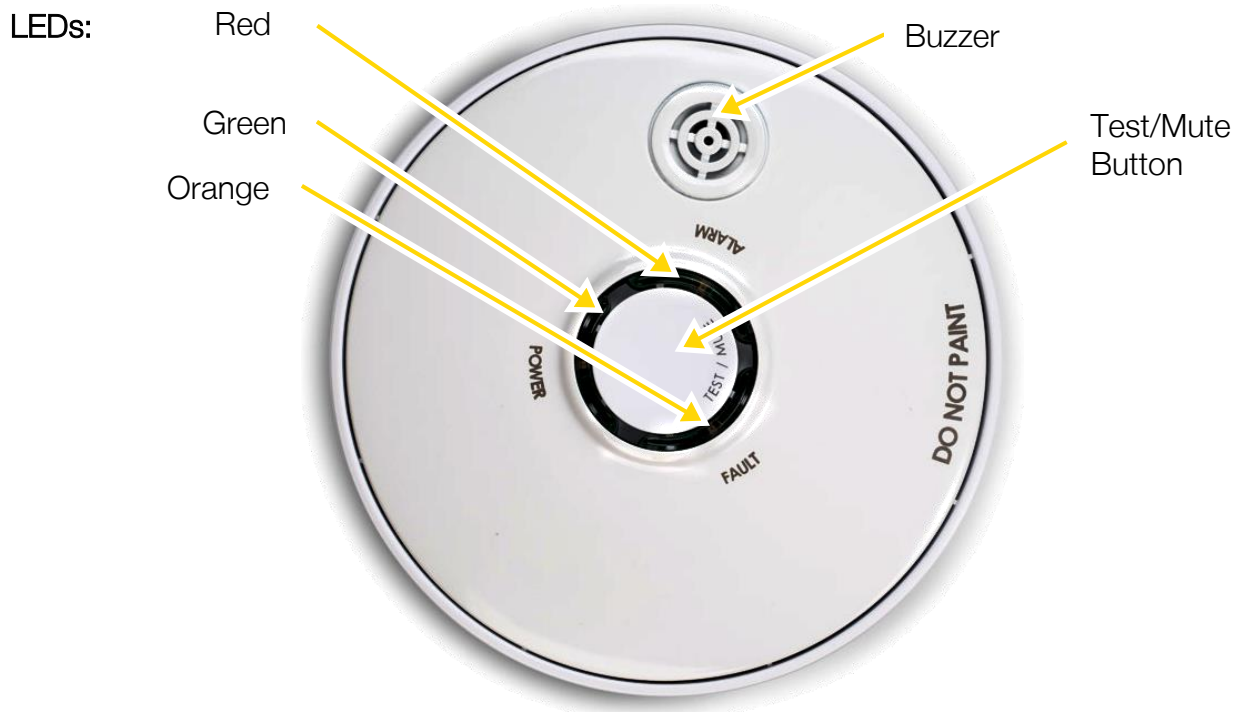

Figure 126: The Smoke Detector Front Panel



WARNING! Never disable the Smoke Detector device and never remove the batteries to stop a nuisance alarm.

To eliminate the alarm, open a window or use a fan to remove the smoke around the device. The alarm will turn itself off as soon as the smoke scatters.

If a nuisance alarm persists, clean the Smoke Detector as described in paragraph 3.12.2.3 below.

Do not stand close to the Smoke Detector when the alarm is on. The alarm is very loud in order to wake you up in case of an emergency. Continuous exposure to the buzzer sound at close range may be harmful to your hearing.

3.12.1. Product Function

The Smoke Detector incorporates the following functions:

- Bi-directional wireless sensor.
- The alarm functions even if RF connectivity with the Central Control Unit is lost.
- Data security is ensured with 128-bit AES encryption.
- Up to 500m (1640 feet) RF range (open air) communication.
- Unique electronic serial number.
- Supports automatic over-the-air software upgrade programming and configuration.
- Tamper Alarm – when the device is ripped off its base.
- Special mechanism to prevent installation without batteries.
- Three (3) colored LEDs indication for Power (green), Alarm (red) and trouble (amber).
- Provides long operation period while powered by two (2) standard AA-size Alkaline batteries.
- Complies with all major electromagnetic compatibility/interference, safety, security, reliability, and environmental standards for smoke detectors.

3.12.2. Installing the Smoke Detector

The Smoke Detector is designed for residential zones only. It can be used in a single family home or in apartment buildings. In multi-family buildings, each apartment needs to install its own Smoke Detector.



WARNING! Do not use this Smoke Detector device in non-residential buildings. Warehouses, industrial buildings, commercial buildings, etc., require special fire detection and alarm systems.

This device is not a substitute for a complete fire detection system for sites where many people live or work (i.e. hotels, motels, dormitories, hospitals, nursing homes and group homes) even if they once were single family homes.

See [NFPA \(National Fire Protection Association\) standard 101](#) (Life Safety Code) and [NFPA standard 72](#) (Fire Alarm and Signaling Code) for fire alarm requirements.

3.12.2.1. Smoke Detector Positioning Recommendations

- For complete coverage in residential units, Smoke Detectors should be installed in all rooms, halls, storage areas, basements, and attics.



WARNING! Smoke Detectors installed in common areas such as porches or outside hallways may not provide sufficient early warning for residents.

- For minimum coverage install one alarm on each floor and one in each bedroom zone.
- Smoke Detectors should be installed in accordance with the [NFPA \(National Fire Protection Association\) standard 72](#).
- For optimal detection, consider these factors when selecting a mounting position:

- ◆ The Smoke Detector should be mounted on the ceiling but may also be mounted on a wall.
- ◆ The Smoke Detector must be installed within 500m (1640 feet) of the Central Control Unit.
- ◆ Install the Smoke Detector in the hallway, close but outside every separated bedroom area, as shown in Figure 127 below. Two alarms are required in homes with two bedroom areas, as shown in Figure 128 below.

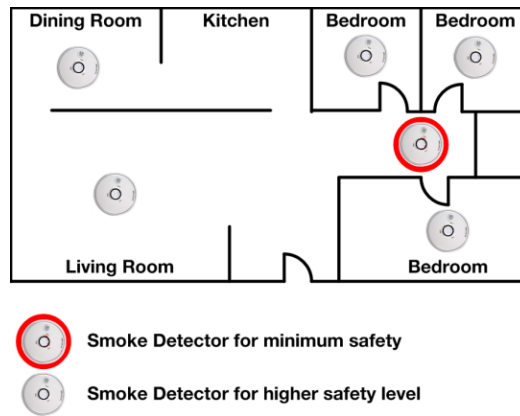

Figure 127: Smoke Detectors in Single Bedroom Area

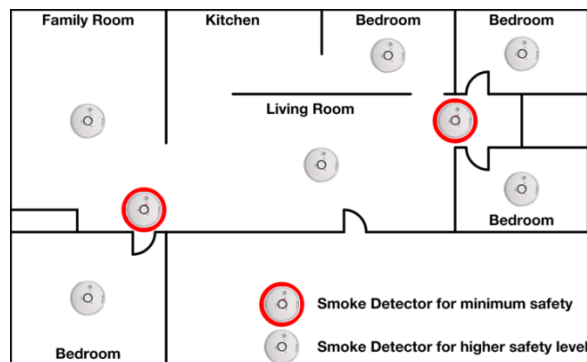



Figure 128: Smoke Detectors in Multiple Bedroom Areas

- ◆ Install a Smoke Detector on every floor of a multi-floor house as shown in Figure 129 below.

 **WARNING!** Make sure doors or other barriers do not block the path of smoke to the Smoke Detectors.

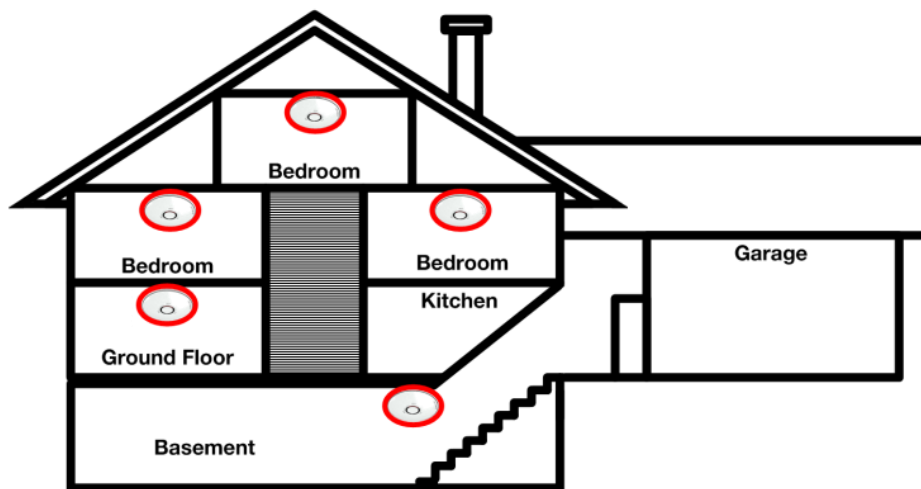

Figure 129: Smoke Detectors in Multi-floor House

- ◆ Install Smoke Detectors at both ends of a bedroom hallway if the hallway is longer than 12 meters (40 feet).
- ◆ Install basement Smoke Detectors at the bottom of the stairway as shown in Figure 129 above.
- ◆ Install the Smoke Detectors as close to the center of the ceiling as possible. If this is not practical, install the Smoke Detector on the ceiling no less than 10 cm (4 inches) away from any wall or corner.
- ◆ If ceiling mounting is not possible and wall mounting is allowed by your local and state codes, mount the Smoke Detectors on a wall 10 to 15 cm (4 to 6 inches) from the ceiling.

- ◆ In rooms with sloped, peaked, or gabled ceilings, mount the Smoke Detectors 90 cm (3 feet) measured horizontally from the highest point of the ceiling.
- ◆ Nuisance alarms occur if Smoke Detectors are installed where they do not work properly. To avoid nuisance alarms, do not install alarms in the following locations:
 - a) Areas where combustion particles are present (i.e. kitchens with few windows or poor ventilation, garages where there may be vehicle exhaust), or near heaters, hot water boilers, etc.
 - b) Less than 6 meters (20 feet) from places where combustion particles are present. If such distance is not available (e.g., in mobile homes), install the alarm as far away from the combustion particles as possible, preferably on the wall. Provide good ventilation in such places.
 - c) Damp or humid areas. Moisture can enter the detection chamber. Upon cooling, the developed water drops may cause nuisance alarms. Install Smoke Detectors at least 3 meters (10 feet) away from bathrooms.
 - d) Very cold or very hot areas, including unheated buildings and outdoor rooms. If the temperature goes above or below the operating range of the Smoke Detector, the device will not work properly.
 - e) Very dusty or dirty areas. Dirt and dust can build up in the Smoke Detector's chamber, making it over-sensitive. In addition, dust or dirt can block openings to the chamber and keep the Smoke Detector from sensing smoke.
 - f) Drafty areas and areas near fresh air vents, air conditioners, heaters or fans. These can drive smoke away from smoke alarms.
 - g) Dead air spaces near the top of a peaked roof or in the corners formed by ceilings and walls. Dead air can prevent smoke from reaching the Smoke Detector.
 - h) In insect-infested areas. If insects enter the Smoke Detector's chamber, they may cause a nuisance alarm.

- i) Near fluorescent lights. Electrical discharges from fluorescent lights can cause nuisance alarms. Install Smoke Detectors at least 1.5 meters (5 feet) from such lights.



WARNING! To prevent injury, the Smoke Detector must be securely attached to the wall/ceiling in accordance with the following instruction.

3.12.2.2. Installing Smoke Detector with Screws

Mounting the Smoke Detector with screws requires the following tools and materials:

- A drill with a standard 5 mm ($\frac{3}{16}$ -inch) bit.
- Standard Phillips screwdriver.
- Two DIN 7982 Philips cross recessed flat countersunk head screws (3.5 x 16 mm) and, pending material of installation site, two plastic, series 108 dowels, with drill hole diameter of 5 mm ($\frac{3}{16}$ -inch) and length of 25 mm (1-inch).



Note: The Smoke Detector base include four (4) holes for screws for flexibility of installation. Only two (2) screws are necessary for a secure installation.

1. Remove the mounting bracket (base of the Smoke Detector) from the device by turning it counter-clockwise as demonstrated in Figure 130 below.

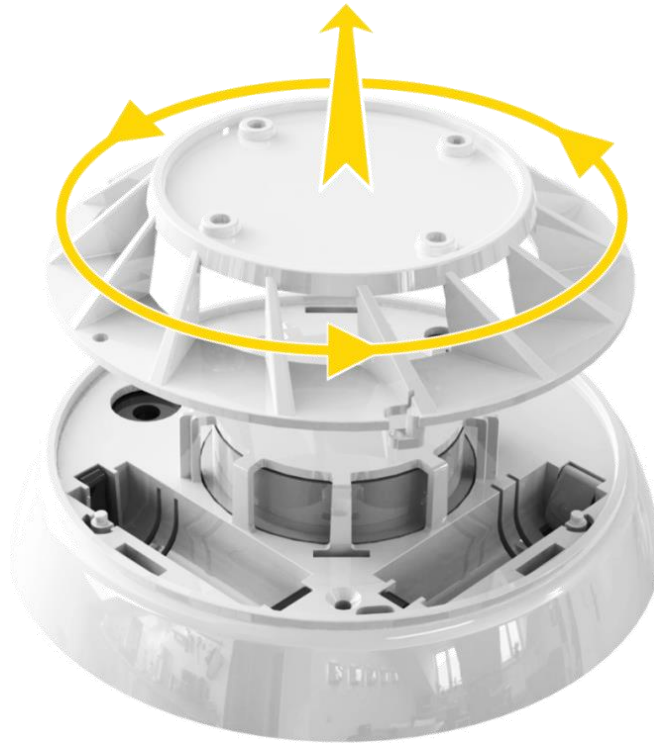

Figure 130: Disassembling the Mounting Bracket of the Smoke Detector

2. Place the Bracket in the installation position. Mark each keyhole slot.
3. Remove the Bracket and use a 5 mm ($\frac{3}{16}$ -inch) drill bit to drill a hole at each of the three marks.



Note: Prevent dust from getting into the Smoke Detector while drilling the holes!

4. Insert the plastic dowels, if needed, into the drilled holes.
5. Attach the Bracket onto the ceiling (or wall) using the two screws.

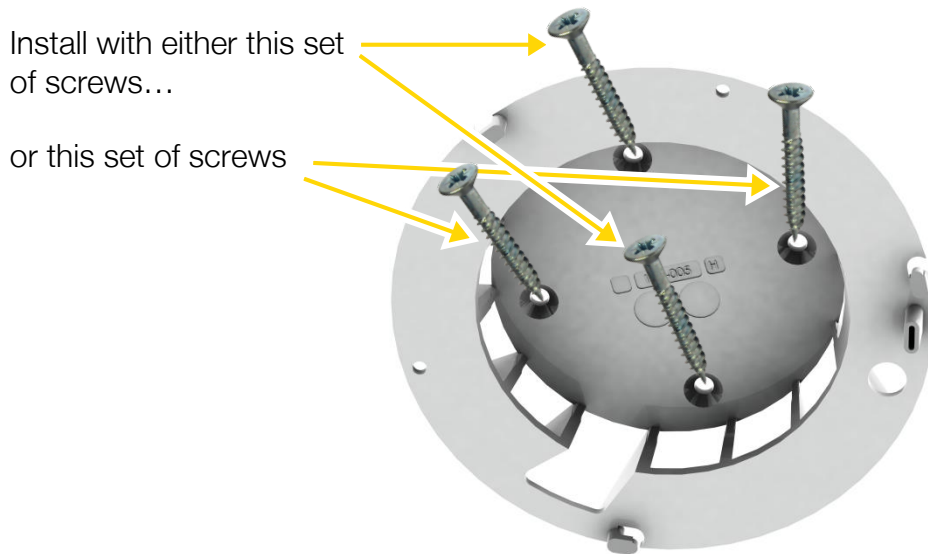

Figure 131: Screw Positions for Mounting the Bracket of the Smoke Detector

The Smoke Detector is now ready for power-up and addition onto the We.R™ system.

3.12.2.3. Cleaning the Smoke Detector

Following the installation and prior to the power-up of the Smoke Detector, or, on a regular basis as detailed below, it is advised to clean the Smoke Detector.

The Smoke Detector is designed to be as maintenance-free as possible. To keep the Smoke Detector in good working condition, there is a need to test the device once a month and clean it once a year.

To clean the Smoke Detector, dismount it from the bracket, remove the batteries, and vacuum the dust out of the detection chamber. Use the soft brush of the vacuum cleaner to remove dust and dirt from the detection chamber.



Note: Do not use water or detergents since they can damage the device.

Carefully remove any dust residing on the Smoke Detector's components applying special attention to the openings of the detection chamber.

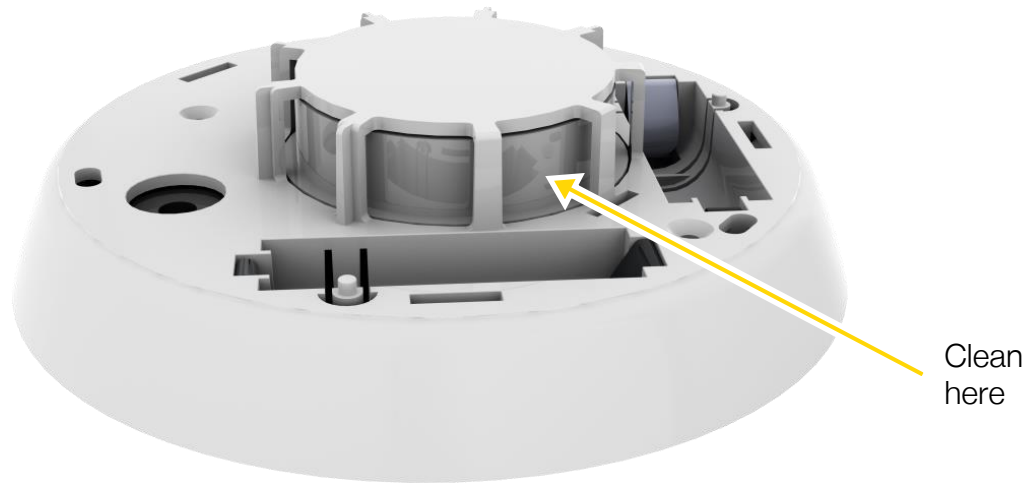

Figure 132: Cleaning the Smoke Detector

After cleaning, replace the batteries, and then test the smoke alarm, by pressing the Test/Mute button, to make sure it is functioning properly.

3.12.3. Adding the Smoke Detector to the We.R™ System

The Smoke Detector need to be functionally added to the system following the above described physical installation procedure.

The addition of the Smoke Detector is a standard **Add Device** procedure performed as follows:



Note: You may also want to refer to paragraph 5.1 below to get acquainted with the process of installing/replacing batteries in the Smoke Detector.

1. Prepare two (2) AA-size Alkaline batteries required to power the Smoke Detector.
2. Activate the We.R™ Web Application.
3. Select the Devices page (tab) and click over the **Add New Device** button.
4. A roll-down selection menu will open.
5. Click over the menu's **Add Smoke Detector** option of the menu as illustrated in Figure 133 below:

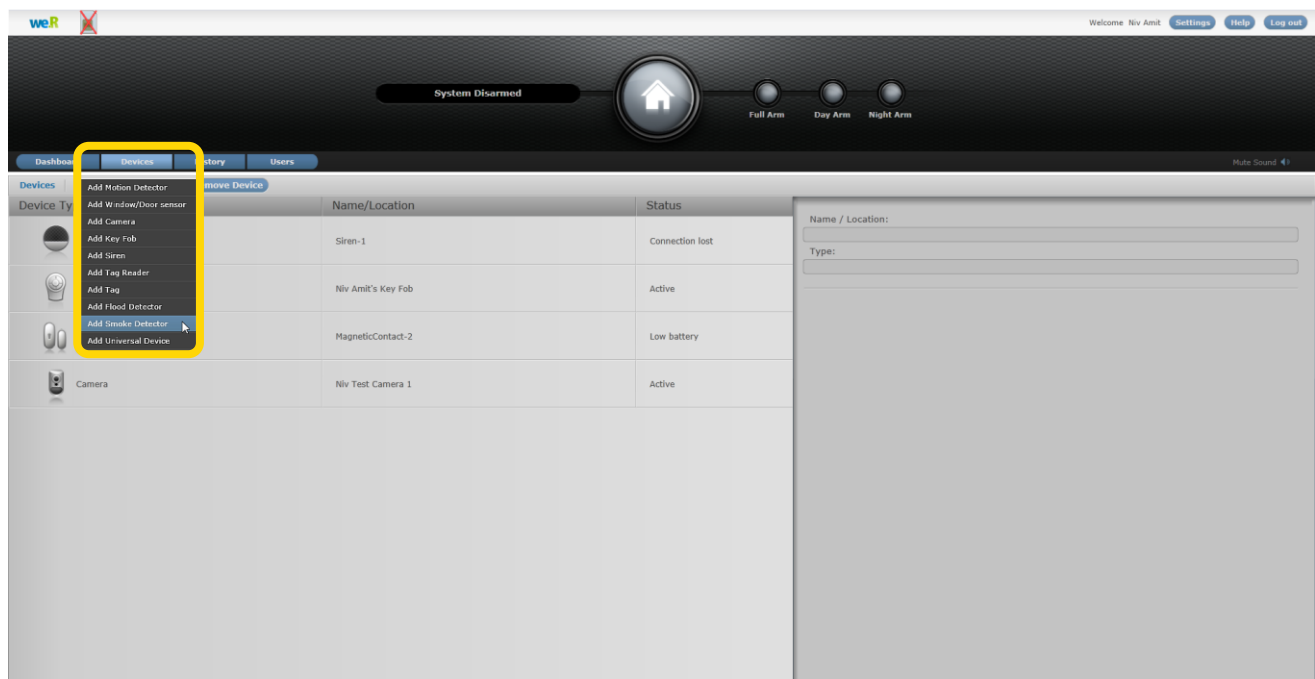

Figure 133: Add Smoke Detector Device Utilizing Web Application

An Add New Device (Smoke Detector) window will pop-up and its timer will start running.

6. Verify that the Device Type is Smoke Detector.



Figure 134: Add Smoke Detector Window

7. The down-counter provides a time-frame of three (3) minutes within which the two batteries should be installed to power-up the Smoke Detector, as demonstrated in Figure 135 below:

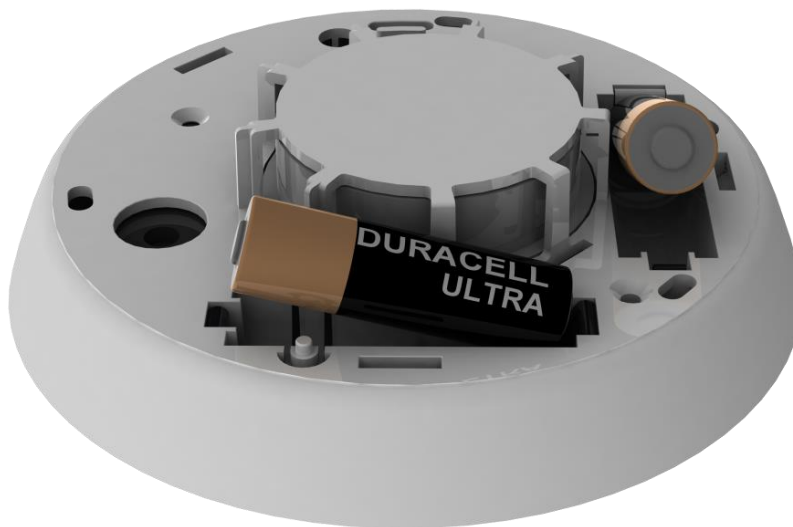

Figure 135: Inserting a Batteries into the Smoke Detector

Verify batteries' polarity to match marking within the batteries' cavities.

8. Insert the Smoke Detector body into the previously installed Mounting Bracket.

This step of the installation must be very carefully done as the mechanical connection between these two parts (the Mounting Bracket and the Smoke Detector's body) was specially designed to:

- ◆ Prevent insertion of the Smoke Detector body without the batteries installed properly.
- ◆ Provide omni-directional assembly (note the enforcing key in Figure 136 below).
- ◆ Ensure secured assembly by three (3) locking pins (note marked keys in Figure 136 below).
- ◆ Provide the mechanism for tamper prevention.

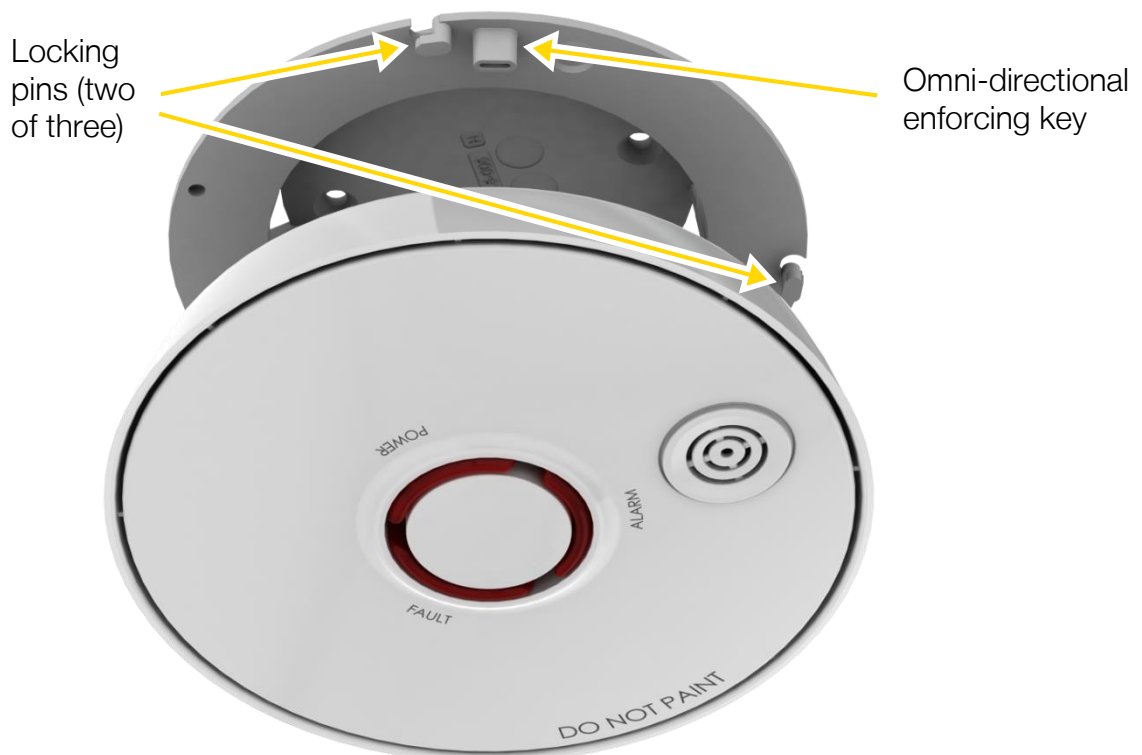

Figure 136: Omni-directional Assembly of the Smoke Detector

9. Line-up the locking pins and the direction enforcement pin, push the Smoke Detector's body into the Mounting Bracket and turn it clockwise until it clicks and locks into position.
10. Confirm proper locking by pulling the body slightly out of the Mounting Bracket.



Note: In case the installation of the batteries could not be accomplished within the three (3) minutes period, it is possible to restart the process by applying step 2 (on page 166) and onwards again.

11. The insertion of batteries into the Smoke Detector triggers a handshake process in which the Smoke Detector communicates with the CCU to inform it of its presence and the CCU add it to its peripherals' inventory.



Note: When the batteries make the initial contact with the Smoke Detector electronic circuit, the tamper prevention sub-system might sound. This means that the Smoke Detector is working properly and indicated that the batteries are installed correctly.

12. If the CCU did not detect the new Smoke Detector within this time-frame, the following error (✖) message will appear within the **Add New Device** window:

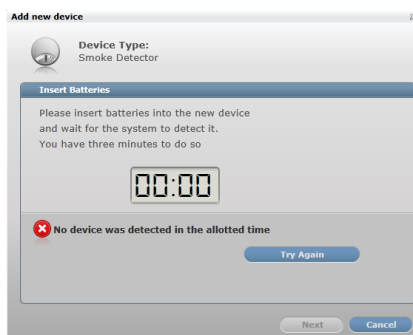

Figure 137: Add New Smoke Detector Timeout Error Message

In such a case, it is possible to re-initiate the Add New Device process by clicking over the **Try Again** button.

Clicking over the **Cancel** button will terminate the Add New Device process.

13. If the new Smoke Detector was properly detected by the CCU within this time-frame, the counter will freeze and a **Device Properties** sub-window will appear within the **Add New Device** window, where the Smoke Detector's system name/location needs to be typed-in.

Clicking over the **Finish** button will end the Add New Device process while the new Smoke Detector is added onto the system configuration.



Figure 138: Add New Smoke Detector Device Properties

14. You may verify that the Smoke Detector (SK2) was properly added by checking the details of the We.R™ Web Application's **Devices** page.

3.12.3.1. Testing the Smoke Detector

Perform a test, following the mechanical installation of the Smoke Detector, by pressing the Test/Mute button (center of the front panel) firmly for about 3 seconds until the buzzer sounds and all three (3) LEDs blink.

The buzzer will produce a loud, pulsating alarm if the unit is working properly.