

# HD CCTV

## EDH5102

### 1080p Mini Dome Camera

---

*User's Manual*



**EverFocus**

Copyright © EverFocus Electronics Corp,  
Release Date: October, 2012

## Cautions

1. Do not install the camera near electric or magnetic fields.
2. Never disassemble the camera beyond the recommendations in this manual nor introduce materials other than those recommended herein.
3. Try to avoid facing the camera toward the sun.
4. Keep the power cable away from water and other liquids and never touch the power cord with wet hands.
5. Never install the camera in areas exposed to oil, gas or solvents.
6. Do not operate the camera beyond the specified temperature or humidity. Use the camera at temperatures within  $-10^{\circ}\text{C}\sim 45^{\circ}\text{C}$  ( $14^{\circ}\text{F}\sim 113^{\circ}\text{F}$ ) and humidity between 20%~ 80%; this device is not rated as submersible.
7. Determine the **polarity** of the power adapter pigtail before connecting the camera to the power source. The input power source is **12V DC**.

# Contents

|  |           |
|--|-----------|
| <b>1. INTRODUCTION.....</b>                  | <b>1</b>  |
| 1.1 PACKING LIST .....                       | 1         |
| 1.2 FEATURES .....                           | 1         |
| <b>2. CABLE DESCRIPTION.....</b>             | <b>2</b>  |
| <b>3. INSTALLATION .....</b>                 | <b>3</b>  |
| 3.1 INSTALLATION AND ADJUSTMENT .....        | 3         |
| <b>4. CONFIGURATION IN THE OSD MENU.....</b> | <b>5</b>  |
| 4.1 OSD MENU.....                            | 5         |
| 4.1.1 EXPOSURE .....                         | 5         |
| 4.1.2 COLOR .....                            | 6         |
| 4.1.3 IMAGE.....                             | 7         |
| 4.1.4 BLC.....                               | 8         |
| 4.1.5 3D-DNR.....                            | 9         |
| 4.1.6 MOTION .....                           | 10        |
| 4.1.7 SYSTEM .....                           | 11        |
| <b>5. SPECIFICATIONS .....</b>               | <b>13</b> |
| <b>6. APPENDIX .....</b>                     | <b>14</b> |
| 6.1 OSD MENU STRUCTURE .....                 | 14        |

## 1. Introduction

The EDH5102 is an HDcctv indoor mini dome camera. Based on a progressive scan CMOS sensor, the camera provides 1080p high resolution images and superior video quality compared to traditional CCTV images. This superior resolution not only captures more critical evidentiary information, but the inherent ability for megapixel video also extends the area of coverage, expedites completion of investigations, resolves complaints and reduces both capital and operational costs.

No major upgrade to the IT network is required to deploy this powerful technology; HDcctv cameras communicate at digital speeds up to 1.5 Gb/s over existing or new coaxial cable (RG59 or other types for longer distances), using industry standard BNC connectors. The EDH5102 supports both NTSC and PAL scanning systems.

### 1.1 Packing List

- Camera body x 1
- Power Adapter (with OSD Menu Joystick) x 1
- Accessory kit x 1 (Screw x 2 , Anchor x 2)
- User Manual x 1
- Template x 1
- Power Adapter Pigtail x 1

### 1.2 Features

- Real time HDcctv 1080p HD video over coax for superlative image detail
- 1/3" 2.1 megapixel Color Progressive CMOS sensor
- Provides 3D DNR / DSS to improve image clarity, particularly in low light scenes
- Electronic Lens Shading Compensation to offset diminished light transmission through lens periphery for uniform image illumination
- CTB [Contrast Boost] to deliver properly exposed images despite bright light sources, deep shadows and/or unbalanced lighting in the same scene
- Supports Digital Zoom / BLC [Back Light Compensation] / HLMASK [Highlight Suppression Mask] / Privacy Zones (up to 32)
- DPC [Defect Pixel Correction] Dead pixel compensation for increased clarity and extended service life
- SD TV Out for aim and focus using a standard hand held test monitor

## 2. Cable Description



| No. | Name                  | Descriptions  |
|-----|-----------------------|---|
| 1   | <b>Power Cable</b>    | Connects to a DC 12V power source.  |
| 2   | <b>HDcctv Output</b>  | Connects to an HDcctv device, such as a DVR or HD monitor, using a 75 Ohm BNC-type coaxial cable. |
| 3   | <b>RS485+ (Green)</b> | Connects to an RS-485 device, such as EverFocus' EKB500 keyboard.                                 |
| 4   | <b>RS485- (Blue)</b>  | Connects to an RS-485 device, such as EverFocus' EKB500 keyboard.                                 |
| 5   | <b>Test-Out</b>       | Connects to a SD CVBS monitor for setting image aim and focus.                                    |

### 3. Installation

#### 3.1 Installation and Adjustment

1. Stick the mounting **template** on the position where you want to attach the camera.
2. Drill the two holes on the template for screwing the camera with the supplied screws and anchors, and the circle in the middle only if you want to wire the cables through the wall / ceiling.
3. Insert the supplied anchors into the holes.
4. Remove the cover cap from **the camera body**.

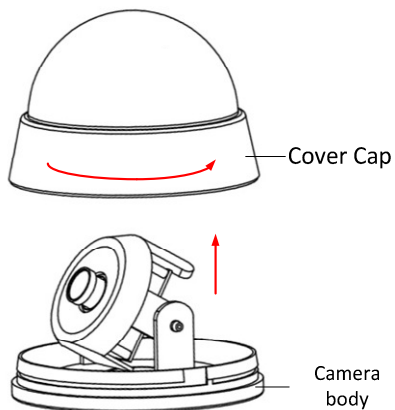

5. Attach the camera body to the correct position and then screw the camera body to the wall / ceiling using the supplied two screws.

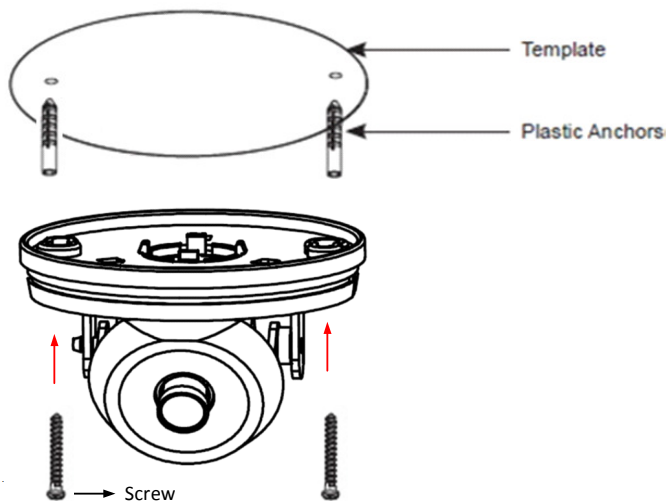

6. Connect the camera to the 12V DC power source using the supplied power adapter pigtail or a power adapter.

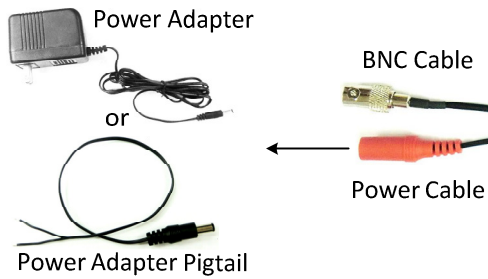

7. Connect the camera to a DVR or a portable monitor using the Test-Out cable for viewing the camera view while adjusting camera angles. You can also use the OSD Menu Joystick to configure camera settings.
  - a. Adjust camera angles by tilting or rotating the camera.

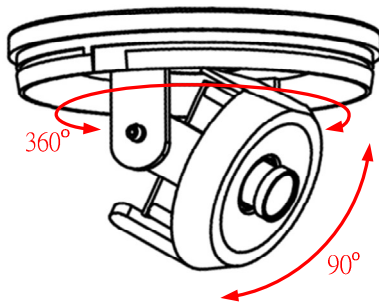

- b. To configure camera settings using the OSD Menu Joystick, connect one end of the Test-Out cable to the Test-Out connector on the camera module and the other end to the portable monitor.

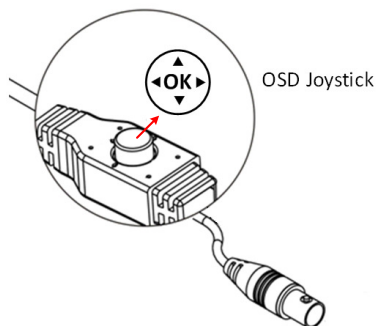
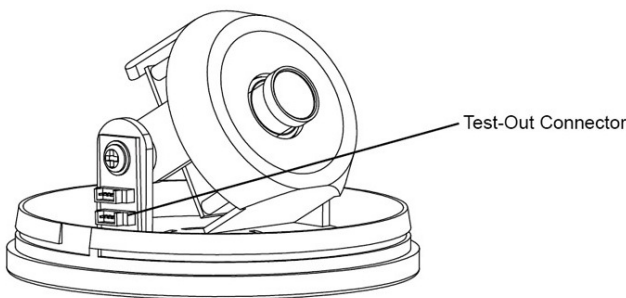

- Push the Joystick up / down to select among menu items.
- Push the Joystick left / right to adjust the level of the selected item.
- Press the Joystick to enter the submenu or exit the OSD Setup Menu.

- Screw the camera cover cap back to the camera.

## 4. Configuration in the OSD Menu

You can use the Joystick on the rear panel of the camera to configure camera settings in the OSD menu. For details on the OSD menu structure, see *OSD Menu Structure* in *Appendix*.

### 4.1 OSD Menu

Press the **Enter / Confirm** button on the Joystick. The Setup Menu in the OSD appears.

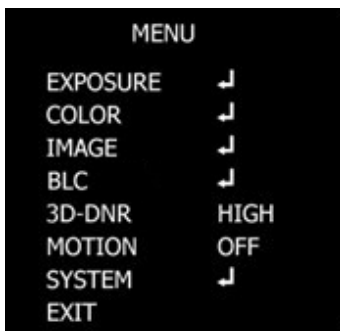

#### 4.1.1 Exposure

Press the **Enter / Confirm** button to enter the submenu.

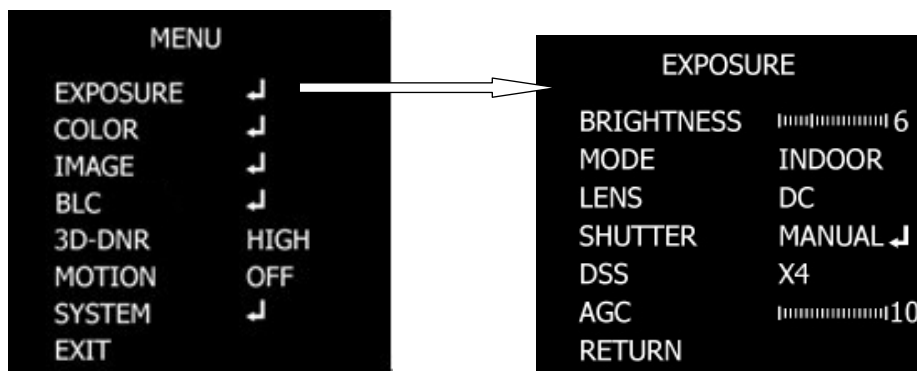

#### **BRIGHTNESS**

Use the ◀ and ▶ buttons to increase or decrease the screen brightness from 0 to 20.



**MODE**

**Indoor**

Select this mode when the color temperature of the video image is similar to that found in indoor environments (around 5100 to 5300°K).

**Outdoor**

Select this mode when the color temperature of the video image is similar to that found in outdoor environments (around 3,000°K to 3,200°K)

**LENS**

You can select the type of the lens. Two types are available: Manual and DC. By default, the Manual type lens is selected.

**Shutter**

Use the ◀ and ▶ buttons to adjust the shutter speed. The options include: 1/25 ~ 1/60000, FLK, and AUTO. Any selection other than AUTO and 1/25 will disable the DSS function.

**DSS (Digital Slow Shutter)**

DSS is used to maintain a vivid screen image by automatically boosting low light levels. The value is between x2 ~ x4 and OFF.

**AGC (Auto Gain Control)**

The higher the AGC value, the brighter the screen, but the level of noise will also be increased. The options include: 0~10.

**4.1.2 Color**

Press the **Enter / Confirm** button to enter the submenu.

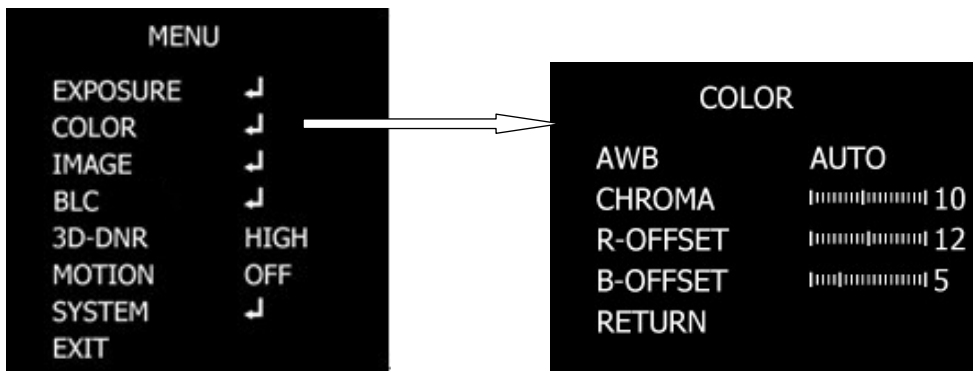

**AWB (Auto White Balance)**

This mode can be used to view areas with a color temperature range. Use the ◀ and ▶ buttons to select the AWB options. The options include: AUTO, AUTO EXTN, PRESET, MANUAL COLOR TEMP, R-GAIN and B-GAIN.

- AUTO – Around 2500 to 9500°K
- AUTO EXTN (Extension) – Around 2300 to 10800°K
- PRESET – Use a pure white background to preset the white balance value.
- MANUAL COLOR TEMP – Use the ◀ and ▶ buttons to adjust the speed. The options include: LOW, MIDDLE and HIGH
- R-GAIN and B-GAIN –The options include: 0~20.

**CHROMA**

Use the ◀ and ▶ buttons to increase or decrease the CHROMA from 0 to 20.

**R-OFFSET/B-OFFSET**

Use the ◀ and ▶ buttons to increase or decrease the Red and Blue offset from 0 to 20.

**4.1.3 Image**

Press the **Enter / Confirm** button to enter the submenu.

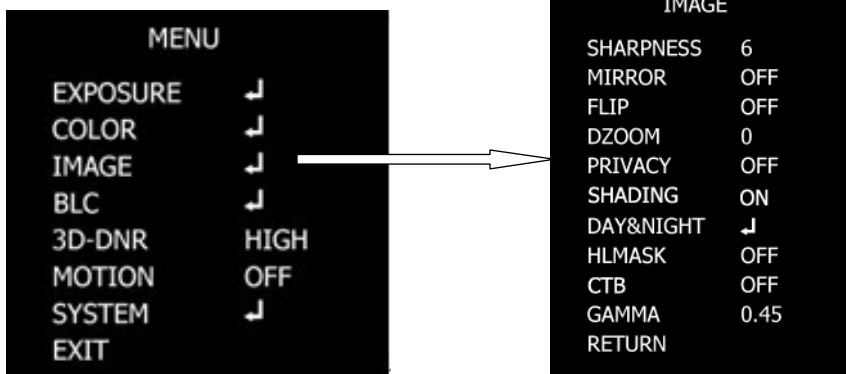

**SHARPNESS**

Use the ◀ and ▶ buttons to increase or decrease the SHARPNESS from 0 to 10.

**MIRROR / FLIP**

Turn it on to reverse / flip the image.

**DZOOM**

Turn it on to set up the zoom level

### PRIVACY

Enter the submenu to set up the privacy masks; up to 31 zones can be created:

**ON ZONE NO:** Use the ◀ and ▶ buttons to select the zone from 0 to 31.

**X, Y-POS, SIZ:** Enter the submenu to set up the position or size of the privacy mask zone.

**COLOR:** Press to select a color for the selected privacy mask zone.

**TRANS:** Press to select the transparency of mask zone.

### SHADING

Turn it on to offset diminished light transmission through lens periphery for uniform image illumination.

### DAY&NIGHT

The options include MODE, AGC THRS, DELAY. A submenu can be entered if you select MODE.

- **MODE** – Use the ◀ and ▶ buttons to select AUTO, COLOR and B&W. Switches to a B&W feed in low light conditions and then switches back to a Color feed in the daytime.
- **AGC THRS** – Use the ◀ and ▶ buttons to select the AGC Threshold from 0 to 20.
- **DELAY** – Set up the delay time in 0,5,10 and 30 seconds for the camera to switch between Day and Night.

### HLMASK

Turn it on to select the level and color of the masking effect. You can adjust the level to control the mask range. The higher the level, the brighter the camera will detect to apply the mask.

### CTB (Contrast Boost)

Turn it on to deliver properly exposed images despite bright light sources, deep shadows and / or unbalanced lighting in the same scene.

### GAMMA

Use the ◀ and ▶ buttons to increase or decrease the GAMMA from 0.45 to 0.75.

---

#### 4.1.4 BLC

Press the **Enter / Confirm** button to enter the submenu.

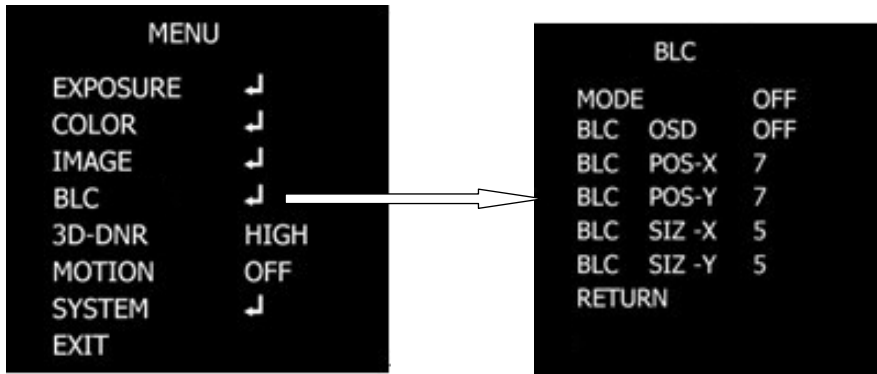

**MODE**

Use the ◀ and ▶ buttons to select OFF and BLC.

**BLC OSD, POS and SIZ**

Select OFF to disable the BLC function, or select ON to enable the BLC function and for further setup. After selecting an area block, enter the BLC POS / SIZ and X / Y setup page, a "POSITION" sign displayed on the screen. Use the direction buttons to move the area to the desired position. Press the **Enter / Confirm** button to confirm the position, a "SIZE" sign displayed on the screen. Use the direction buttons to adjust the size for the area.

**4.1.5 3D-DNR**

Press the **Enter / Confirm** button to enter the submenu.

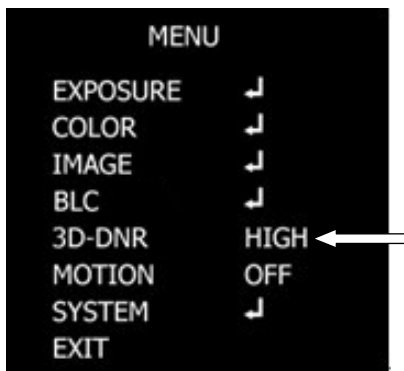

Switch to HIGH, MIDDLE, LOW and OFF to enable or disable noise reduction on dynamic recordings.

**4.1.6 Motion**

Press the **Enter / Confirm** button to enter the submenu.

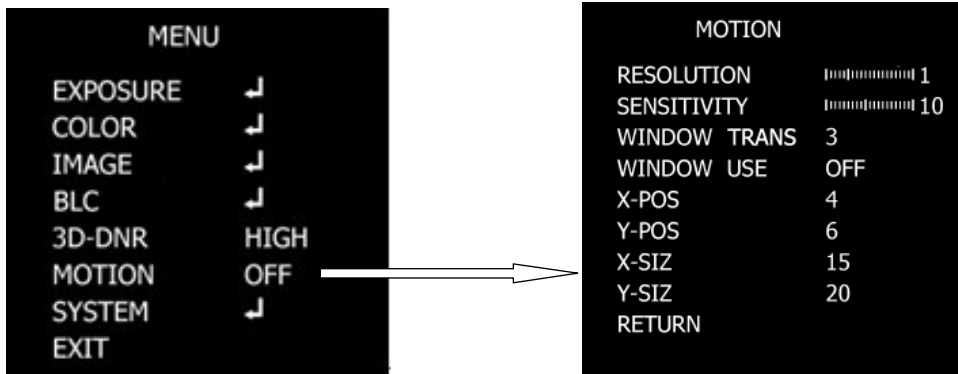

**RESOLUTION**

Use the ◀ and ▶ buttons to increase or decrease the RESOLUTION level from 0 to 4.

**SENSITIVITY**

Press to set up the sensitivity for the motion detection function.

**WINDOW TRANS**

Press to select the transparency of motion detect zone.

**WINDOW USE, POS and SIZ**

Select OFF to disable this function, or select ON to enable and for further setup. After selecting an area block, enter the BLC POS / SIZ and X / Y setup page, a "POSITION" sign displayed on the screen. Use the direction buttons to move the area to the desired position. Press the **Enter / Confirm** button to confirm the position, a "SIZE" sign displayed on the screen. Use the direction buttons to adjust the size for the area.

**4.1.7 System**

Press the **Enter / Confirm** button to enter the submenu.

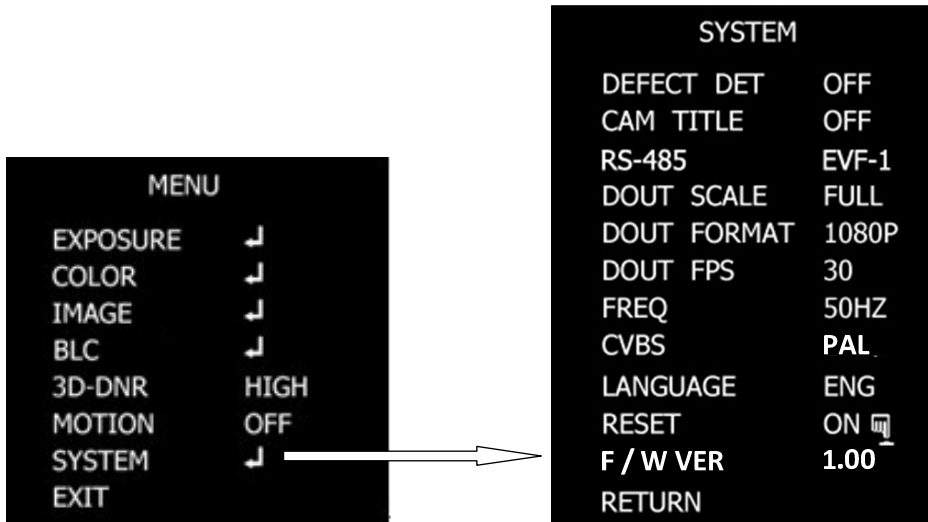

**DEFECT DET**

Press to select the DPC (Defective Pixel Correction) level of defect detector. Please notice; do not use this function without cover the lens. The camera will automatically correct pixel defects. Misoperation will cause the abnormal image.

**CAM TITLE**

Switch to On and then enter the submenu to set up a camera name displayed on the screen.

**RS-485**

Use the ◀ and ▶ buttons to select ID, BAUDRATE, PROTOCOL and ID DISPLAY. The default of protocol is EVF-1 (EverFocus).

**DOUT SCALE: Digital Output Scale**

Use the ◀ and ▶ buttons to select FULL or COMP. This function is used to select the value range of auto brightness control. The value range of FULL and COMP is as below:

**FULL:** 0-255

**COMP:** 16-255

**DOUT FORMAT : Digital Output Format**

**DOUT FPS: Frames per Second**

**FREQ: Frequency**

**CVBS**

There are 4 options including 1080p 30FPS NTSC, 1080p 25FPS PAL, 720p 60FPS NTSC and 720p 50FPS PAL. If you want to change the format and FPS, you should change the FREQ first. Select

50HZ frequency, the CVBS will automatically change to PAL; select 60HZ frequency, the CVBS will turn to NTSC. Then, you can select the 720P or 1080P in the format options, and the FPS will also change accordingly.

**LANGUAGE**

Select a language for the OSD text. Options include English, French, German, Simplified Chinese, Korean and Japanese.

**RESET**

Turn it on to reset the settings.

**F / W VERSION: Firmware Version**

Press to display the firmware version of the camera.

## 5. Specifications

|                                     |   |
|-------------------------------------|---|
| <b>Pickup Device</b>                | 1/3" Panasonic 2.1 megapixel Color Progressive CMOS sensor            |
| <b>Image Pixels</b>                 | 1920(H) x 1080(V)   |
| <b>Resolution</b>                   | Digital: 1080p (30 / 25), 720p (60 / 50)                              |
| <b>Scanning System</b>              | NTSC / PAL  |
| <b>Sensitivity</b>                  | Color: 0.4 lux, BW: 0.1 lux,<br>Color DSS: 0.1 lux, BW DSS: 0.025 lux |
| <b>Video Output</b>                 | Digital (HDcctv Output): BT.1120, HDcctv / HD-SDI: BNC connector      |
|                                     | Analog (Test Out): NTSC / PAL : BNC connector                         |
| <b>S/N Ratio</b>                    | More than 50 dB (AGC OFF)   |
| <b>Lens</b>                         | Manual  |
| <b>AGC</b>                          | 0-20 steps  |
| <b>Shutter Speed</b>                | AUTO / MANUAL(1/25(30)~1/60,000sec)                                   |
| <b>Digital Slow Shutter(DSS)</b>    | On / Off(x4)  |
| <b>Brightness</b>                   | 0-20  |
| <b>BLC</b>                          | On / Off  |
| <b>Contrast Boost(CTB)</b>          | On / Off  |
| <b>Day&amp;Night</b>                | Auto / Color / B&W  |
| <b>Auto White Balance</b>           | Auto / Auto extn / Preset / Manual                                    |
| <b>Digital Noise Reduction(DNR)</b> | Off / Low / Middle / High   |
| <b>Mirror</b>                       | On / Off  |
| <b>Flip</b>                         | On / Off  |
| <b>Sharpness</b>                    | 0 - 10 steps  |
| <b>Lens Shading Compensation</b>    | On / Off  |
| <b>Digital Zoom</b>                 | 0 - 96 steps  |
| <b>Privacy Mask</b>                 | 32 Zones, Programmable  |
| <b>Motion Detection</b>             | On / Off  |
| <b>RS - 485</b>                     | 2400~115200> baud, ID 1~255, Protocols: Pelco-D/P, EverFocus EVF-1;   |
| <b>Language</b>                     | English / French / German / Simplified Chinese / Japanese             |
| <b>Power Source</b>                 | 12VDC   |
| <b>Power Consumption</b>            | 12VDC: 2W max.  |
| <b>Operating Environment</b>        | -10°C~45°C / 14°F~113°F (20%~80% Humidity)                            |
| <b>Dimensions(Φ x H)</b>            | 95 x 72mm / 3.7" x 2.8"   |
| <b>Weight</b>                       | 0.190kg / 0.430lbs  |
| <b>Certifications</b>               | FCC / CE  |



## 6. Appendix

### 6.1 OSD Menu Structure

The default value is marked with a star “\*”.

| No. | Main              | Sub Menu   | Sub Menu / Function |                   |
|-----|-------------------|------------|---------------------|-------------------|
| 1   | EXPOSURE          | BRIGHTNESS | 1~20 (default=6)    |                   |
|     |                   | MODE       | INDOOR*, OUTDOOR    |                   |
|     |                   | LENS       | MANUAL*, DC         |                   |
|     |                   | SHUTTER    | AUTO*               |                   |
|     |                   |            | MANUAL              | 1/25~1/60000      |
|     |                   |            | FLK                 |                   |
|     |                   | DSS        | OFF, X2, X3, X4*    |                   |
| AGC | 0~10 (default=10) |            |                     |                   |
| 2   | COLOR             | AWB        | AUTO*               |                   |
|     |                   |            | AUTO extrn          |                   |
|     |                   |            | PRESET              |                   |
|     |                   |            | MANUAL COLOR TEMP   | LOW, MIDDLE, HIGH |
|     |                   |            | R-GAIN              | 0~20              |
|     |                   |            | B-GAIN              | 0~20              |
|     |                   | CHROMA     | 0~20 (default=7)    |                   |
|     |                   | R-OFFSET   | 0~20 (default=12)   |                   |
|     |                   | B-OFFSET   | 0~20 (default=5)    |                   |
| 3   | IMAGE             | SHARPNESS  | 0~10 (default=6)    |                   |
|     |                   | MIRROR     | ON, OFF*            |                   |
|     |                   | FLIP       | ON, OFF*            |                   |
|     |                   | D-ZOOM     | 0~96 (default=0)    |                   |
|     |                   | PRIVACY    | OFF*                |                   |
|     |                   |            | ON ZONE NO          | 0~31              |
|     |                   |            | ZONE UP             | ON, OFF           |
|     |                   |            | X-POS               | 0~60              |
|     |                   |            | Y-POS               | 0~40              |
|     |                   |            | X-SIZ               | 0~60              |
|     |                   |            | Y-SIZ               | 0~40              |
|     |                   |            | COLOR               |                   |
|     |                   |            | TRANS               | 0~4               |

|            |                              |                         |                   |  |                   |  |
|------------|------------------------------|-------------------------|-------------------|--|-------------------|--|
|            |                              | SHADING                 | ON*, OFF          |  |                   |  |
|            |                              | DAY&NIGHT               | MODE              | AUTO*  |                   |  |
|            |                              |                         |                   | COLOR  |                   |  |
|            |                              |                         |                   | B&W  |                   |  |
|            |                              |                         | AGC THRS          | 0~20 (default=10)                              |                   |  |
|            |                              |                         | MARGIN            | 0~20 (default=)                                |                   |  |
|            |                              | DELAY                   | 0, 5*, 10, 30 SEC |  |                   |  |
|            |                              | HLMASK                  | OFF*              |  |                   |  |
|            |                              |                         | ON                | LEVEL  | 0~20 (default=10) |  |
|            |                              | COLOR                   |                   | BLK*/WHT/YEL/CYN/GRN/MAG/RED/BLU               |                   |  |
| CTB        | ON, OFF*                     |                         |                   |  |                   |  |
| GAMMA      | 0.45*, 0.5, 0.55, 0.65, 0.75 |                         |                   |  |                   |  |
| 4          | BLC                          | MODE                    | OFF*, BLC         |  |                   |  |
|            |                              | BLC OSD                 | ON, OFF*          |  |                   |  |
|            |                              | BLC POS-X               | 0~20 (default=7)  |  |                   |  |
|            |                              | BLC POS-Y               | 0~20 (default=7)  |  |                   |  |
|            |                              | BLC SIZ-X               | 0~20 (default=5)  |  |                   |  |
|            |                              | BLC SIZ-Y               | 0~20 (default=5)  |  |                   |  |
| 5          | 3D-DNR                       | HIGH, MIDDLE*, LOW, OFF |                   |  |                   |  |
| 6          | MOTION                       | OFF*                    |                   |  |                   |  |
|            |                              | ON                      | RESOLUTION        | 0~4 (default=1)                                |                   |  |
|            |                              |                         | SENSITIVITY       | 0~20 (default=10)                              |                   |  |
|            |                              |                         | WINDOW TRANS      | 0~6 (default=3)                                |                   |  |
|            |                              |                         | WINDOW USE        | ON, OFF*                                       |                   |  |
|            |                              |                         | X-POS             | 0~60 (default=4)                               |                   |  |
|            |                              |                         | Y-POS             | 0~40 (default=6)                               |                   |  |
|            |                              |                         | X-SIZ             | 0~60 (default=15)                              |                   |  |
| Y-SIZ      | 0~40 (default=20)            |                         |                   |  |                   |  |
| 7          | SYSTEM                       | DEFECT DET              | DPC LEVEL         | 000~255 (default=26)                           |                   |  |
|            |                              | CAM TITLE               | OFF*              |  |                   |  |
|            |                              |                         | ON                | STRING SET                                     |                   |  |
|            |                              | POSITION                |                   |  |                   |  |
|            |                              | RS-485                  | ID                | 1~255 (default=1)                              |                   |  |
|            |                              |                         | BAUDRATE          | 2400, 4800, 9600*, 19200, 38400, 57600, 115200 |                   |  |
|            |                              |                         | PROTOCOL          | PELCO-D, PELCO-P, EVF-1*                       |                   |  |
|            |                              |                         | ID DISPLAY        | ON, OFF  |                   |  |
| DOUT SCALE | FULL*, COMP                  |                         |                   |  |                   |  |

|  |  |                |   |
|--|--|----------------|---|
|  |  | DOUT<br>FORMAT | 720P, 1080P*  |
|  |  | DOUT FPS       | 50, 60 ,25* , 30  |
|  |  | FREQ           | 50* , 60 HZ   |
|  |  | CVBS           | PAL* , NTSC   |
|  |  | LANGUAGE       | English, Simplified Chinese, Japanese, Korean, French, German |
|  |  | RESET          | PUSH, PUSHING   |

## EverFocus Electronics Corp.

### EverFocus Taiwan:

12F, No.79, Sec. 1, Shin-Tai Wu Road,  
Hsi-Chih, Taipei, Taiwan  
TEL: +886 2 2698 2334  
FAX: +886 2 2698 2380  
[www.everfocus.com.tw](http://www.everfocus.com.tw)  
[marketing@everfocus.com.tw](mailto:marketing@everfocus.com.tw)

### EverFocus China - Beijing:

Room 609, Technology Trade Building,  
Shangdi Information Industry Base,  
Haidian District, Beijing 100085, China  
TEL: +86 10 6297 3336~39  
FAX: +86 10 6297 1423  
[www.everfocus.com.cn](http://www.everfocus.com.cn)  
[marketing@everfocus.com.cn](mailto:marketing@everfocus.com.cn)

### EverFocus USA - California:

1801 Highland Avenue, Unit A, Duarte, CA 91010,  
USA  
TEL: +1 626 844 8888  
FAX: +1 626 844 8838  
[www.everfocus.com](http://www.everfocus.com)  
[sales@everfocus.com](mailto:sales@everfocus.com)

### EverFocus Japan:

5F, Kinshicho City Building, 2-13-4  
Koto-Bashi, Sumida-Ku, Tokyo, 130-0022, Japan  
TEL: +81 3 5625 8188  
FAX: +81 3 5625 8189  
[www.everfocus.co.jp](http://www.everfocus.co.jp)  
[info@everfocus.co.jp](mailto:info@everfocus.co.jp)

### EverFocus India:

Suite 803, Housefin Bhavan, C-21, Bandra Kurla  
Complex, Bandra (East), Mumbai 400051, India  
TEL: +91 22 6128 8700  
FAX: +91 22 6128 8705  
[www.everfocus.in](http://www.everfocus.in)  
[sales@everfocus.in](mailto:sales@everfocus.in)

### EverFocus Europe - Germany:

Albert-Einstein-Strasse 1, D-46446  
Emmerich, Germany  
TEL: +49 2822 93940  
FAX: +49 2822 939495  
[www.everfocus.de](http://www.everfocus.de)  
[info@everfocus.de](mailto:info@everfocus.de)

### EverFocus China - Shenzhen:

4F, No. 2, D4 Building, Wan Yelong  
Industrial Park, Tangtou Road, Shiyan,  
Baoan, Shenzhen, Guangdong 518101, China  
TEL: +86 755 2765 1313  
FAX: +86 755 2765 0337  
[www.everfocus.com.cn](http://www.everfocus.com.cn)  
[marketing@everfocus.com.cn](mailto:marketing@everfocus.com.cn)

### EverFocus USA - New York:

415 Oser Avenue, Unit S, Hauppauge, NY 11788, USA  
TEL: +1 631 436 5070  
FAX: +1 631 436 5027  
[www.everfocus.com](http://www.everfocus.com)  
[sales@everfocus.com](mailto:sales@everfocus.com)

### EverFocus Europe - UK:

Unit 12, Spitfire Business Park,  
Hawker Road, Croydon Surrey, CR0 4WD, UK  
TEL: +44 20 8649 9757 / +44 845 430 9999  
FAX: +44 20 8649 9907  
[www.everfocusuk.co.uk](http://www.everfocusuk.co.uk)  
[salesuk@everfocus.com](mailto:salesuk@everfocus.com)



Your EverFocus product is designed and manufactured with high quality materials and components which can be recycled and reused. This symbol means that electrical and electronic equipment, at their end-of-life, should be disposed of separately from your household waste. Please, dispose of this equipment at your local community waste collection/recycling centre. In the European Union there are separate collection systems for used electrical and electronic product. Please, help us to conserve the environment we live in!

Ihr EverFocus Produkt wurde entwickelt und hergestellt mit qualitativ hochwertigen Materialien und Komponenten, die recycelt und wieder verwendet werden können. Dieses Symbol bedeutet, dass elektrische und elektronische Geräte am Ende ihrer Nutzungsdauer vom Hausmüll getrennt entsorgt werden sollen. Bitte entsorgen Sie dieses Gerät bei Ihrer örtlichen kommunalen Sammelstelle oder im Recycling Centre. Helfen Sie uns bitte, die Umwelt zu erhalten, in der wir leben!

