

RF 433Mhz Wireless Remote Sensor 001H22

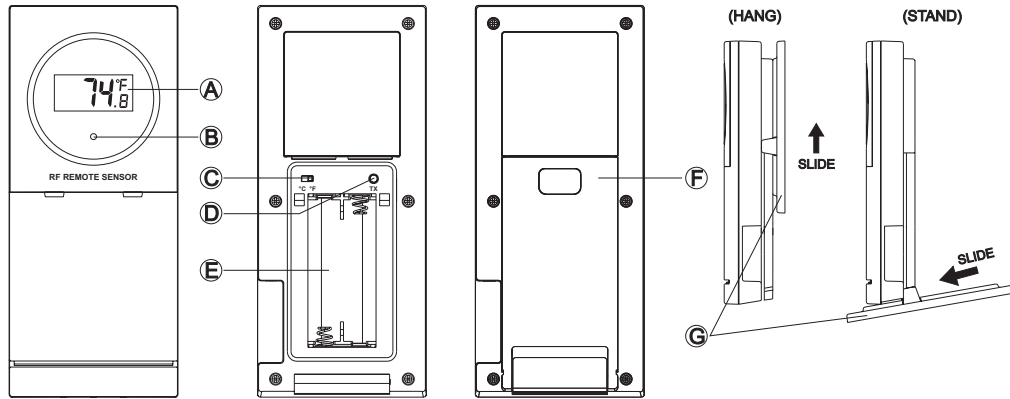

- A. LCD**
Displays temperature and humidity in toggle
- B. LED indicator**
Flashes when the remote unit transmits a reading
- C. °C/°F slide switch**
Selection Centigrade (°C) or Fahrenheit (°F)
- D. TX**
Press once to re-transmit manually. Press and hold to clear the TX ID and start re-registration
- E. Battery compartment**
Accommodates two AAA-size batteries
- F. Battery door**
- G. Removable table stand with wall-mount hole**
To enable the remote unit on a flat surface and support it in wall-mounting.

During the 3 minutes when the home receiver is seeking for sensor registration signal, remove the bracket stand, and battery cover. Insert 2 pieces of AAA batteries into the battery compartment according to polarity markings. The channel 1 icon and the temperature/humidity will appear on the LCD of the receiving unit.

-If the registration is successful, a beep confirmation will be heard. If not, check the AAA batteries, repeat the registration procedure again, or hold the TX button for 2 seconds to send the registration signal. Then, close the battery door.

-To register sensor 2 and sensor 3: Press and hold the "Channel" button for 2 seconds on the home receiver to select the channel. Insert batteries for sensor 2, the channel 2 icon and temperature will appear on the LCD of the receiving unit. Follow the same procedure to register sensor 3.

Note:

- The sensor will transmit the registration code automatically once the batteries are inserted. If the batteries have been already inserted into the battery compartment, hold the TX 2 seconds for registration.
- If the "---" icon appears on the outdoor remote sensor, move the unit closer to the receiving unit. Repeat the registration procedure again.
- The channels will be automatically assigned to the sensors respectively in sequence of registration. However, if all sensors are already registered, you can perform the registration again by selecting the desired channel and hold "Channel" for 2 seconds to enable the receiving unit to receive RF temperature signals.

For wireless remote sensor with detachable probe only

If measurement of water, soil, or other liquid is desired, open the cover of the plug hole at the side of the sensor and insert the probe plug. (optional)

Specification

Recommended remote sensor operating range:	: +32°F to +122°F (0°C to +50°C)
Sensor with LCD display	: -58°F to +158°F (-50°C to +70°C)
Detachable outdoor probe	: Maximum 30 meters, open area
Transmission range	: AAA size x 2 pcs. (remote sensor)
Batteries	: 6 months
Battery life	: 433.92 MHz
Transmission frequency	

This device could be sensitive to electrostatic discharge, If electrostatic discharge or malfunctioning occurs, please reset this unit.

"Modifications not authorized by the manufacturer may void users authority to operate this device"

NOTE: This equipment has been tested and found to comply with the limits for a Class B digital device, pursuant to part 15 of the FCC Rules. These limits are designed to provide reasonable protection against harmful interference in a residential installation. This equipment generates, uses and can radiate radio frequency energy and, if not installed and used in accordance with the instructions, may cause harmful interference to radio communications. However, there is no guarantee that interference will not occur in a particular installation. If this equipment does not cause harmful interference to radio television reception, which can be determined by turning the equipment off and on, the user is encouraged to try to correct the interference by one or more of the following measures;

- Reorient or relocate the receiving antenna.
- Increase the separation between the equipment and receiver.
- Connect the equipment into an outlet on a circuit different from that to which the receiver is connected.
- Consult the dealer or an experienced radio/TV technician for help.

Operation is subject to the following two conditions: (1) this device may not cause interference, and (2) this device must accept any interference, including interference that may cause undesired operation of the device.