

490mm

105mm

**Smart Home System
User Instruction Manual**

Smart Home system include following essentials:

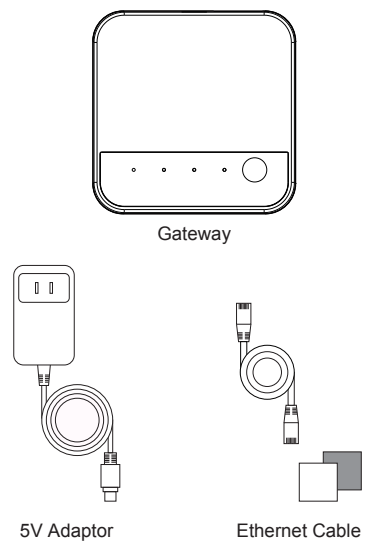

Gateway
5V Adaptor
Ethernet Cable

* This device design for indoor using, no waterproof function;

GRP001 PIR sensor
GRP002 Door/window sensor
GRP006 Water leakage sensor
GRP007 Temperature sensor
GRP008 Indoor sensor

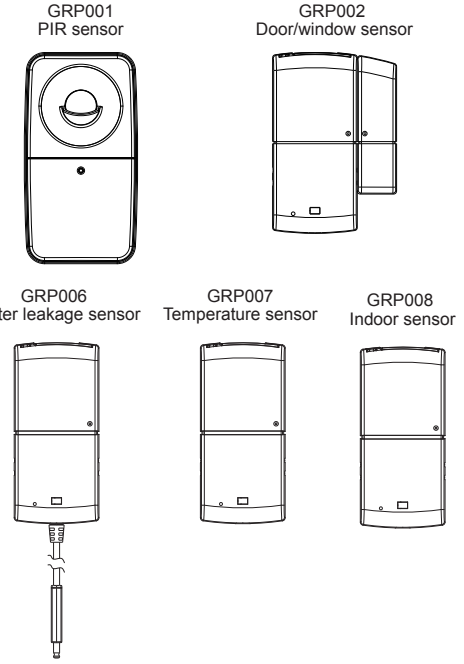

**1st Step
APP download, install**

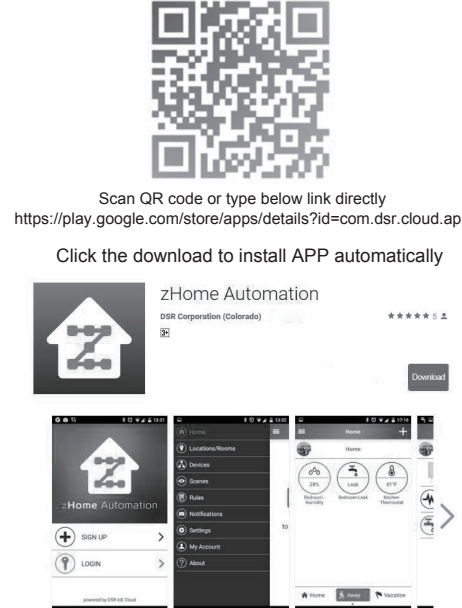

Scan QR code or type below link directly
<https://play.google.com/store/apps/details?id=com.dsr.cloud.app>
Click the download to install APP automatically

**2nd step:
sign up, login**

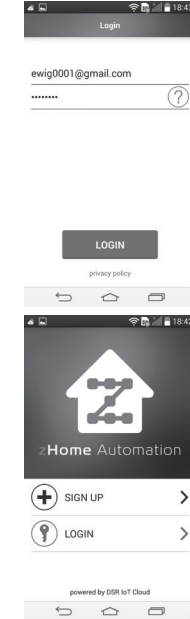

**3rd step:
Identify location**



**4th step:
Add gateway**

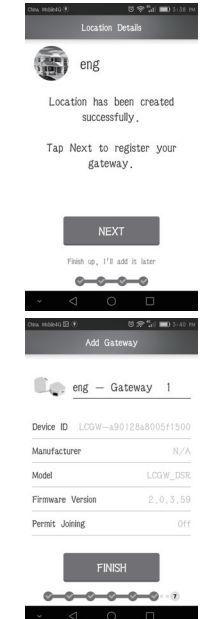

**5th step:
Add sensor**

- 1.Press "add devices" to add sensor;
- 2.Select sensor type;
- 3.Pull out the insulation sheet ;
- 4.Select the install place for sensor;
5. Add others sensor as same step;



**6th Step
User interface**

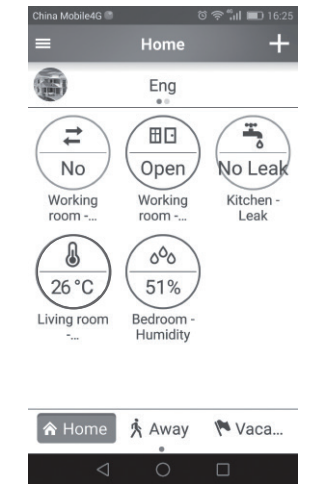

Front side

Hardware Installation

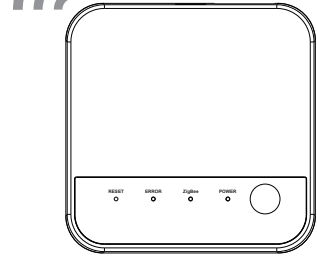

This equipment has been tested and found to comply with the limits for a Class B digital device, pursuant to Part 15 of the FCC Rules. These limits are designed to provide reasonable protection against harmful interference in a residential installation. This equipment generates, uses and can radiate radio frequency energy and, if not installed and used in accordance with the instructions, may cause harmful interference to radio communications. However, there is no guarantee that interference will not occur in a particular installation. If this equipment does cause harmful interference to radio or television reception, which can be determined by turning the equipment off and on, the user is encouraged to try to correct the interference by one or more of the following measures:
-- Reorient or relocate the receiving antenna.
-- Increase the separation between the equipment and receiver.
-- Connect the equipment into an outlet on a circuit different from that to which the receiver is connected.
-- Consult the dealer or an experienced radio/TV technician for help.
Changes or Modifications not expressly approved by the party responsible could void the user's authority to operate this device.
This equipment complies with the FCC RF radiation exposure limits set forth for an uncontrolled environment. This equipment should be installed and operated with a minimum distance of 20 centimeters between the radiator and your body.

Gateway Installation

- Connect the Gateway to internet via modem;

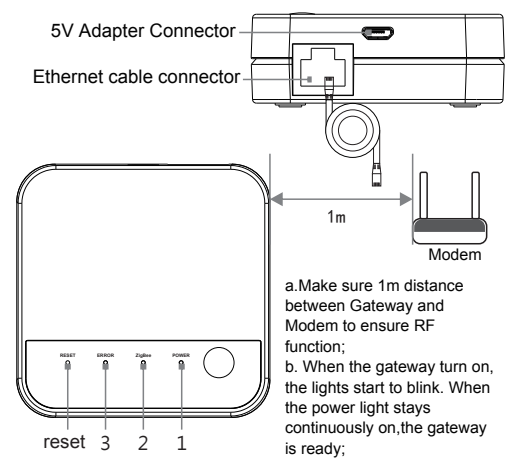

5V Adapter Connector
Ethernet cable connector
Modem

1m

- Make sure 1m distance between Gateway and Modem to ensure RF function;
- When the gateway turn on, the lights start to blink. When the power light stays continuously on, the gateway is ready;

LED's 3 X red, green, orange indicator
1. Power LED - Green LED. It does show Ethernet activities;
2. Zigbee LED - Orange LED. It is used to provide information on some special cases;
3. Error LED - Red LED. It is used to indicate error cases.

**Sensor Installation
PIR sensor**

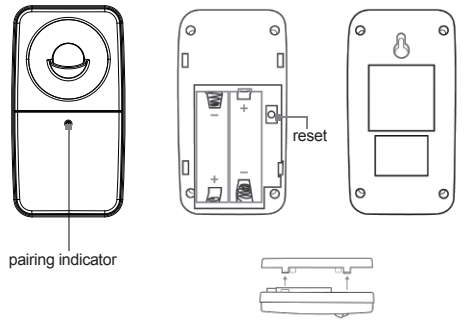

pairing indicator
reset

Open the casing by detaching the back plate; Place AA batteries into compartment; Drill a hole in the wall at about 1.4 meters high, use the provided wall plug to turn the screw in the wall; Mount the sensor by sliding the hole in the top of back plate;

* **Make sure the Lens is pointing upwards.**

Door/Window sensor

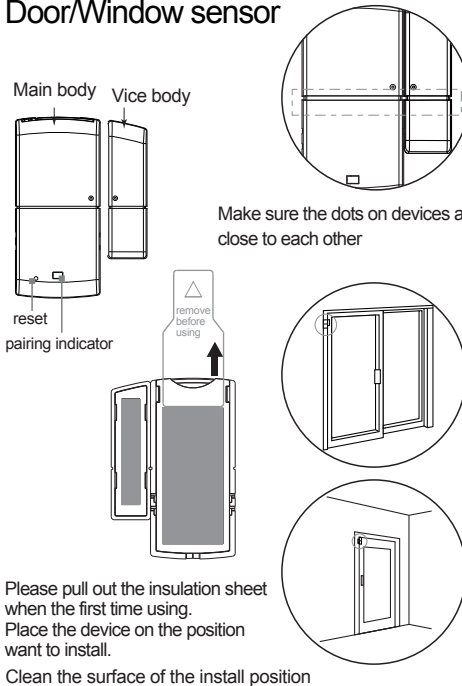

Main body Vice body
reset pairing indicator
remove before using

Make sure the dots on devices are close to each other

Please pull out the insulation sheet when the first time using. Place the device on the position want to install.
Clean the surface of the install position

Temperature sensor

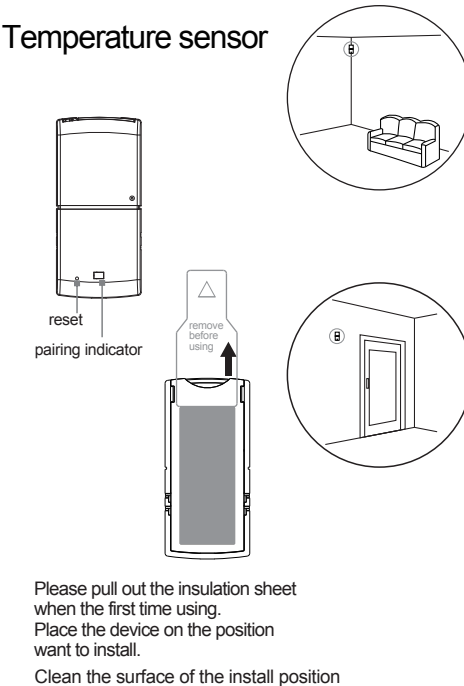

reset pairing indicator
remove before using

Please pull out the insulation sheet when the first time using. Place the device on the position want to install.
Clean the surface of the install position

Water Leakage sensor

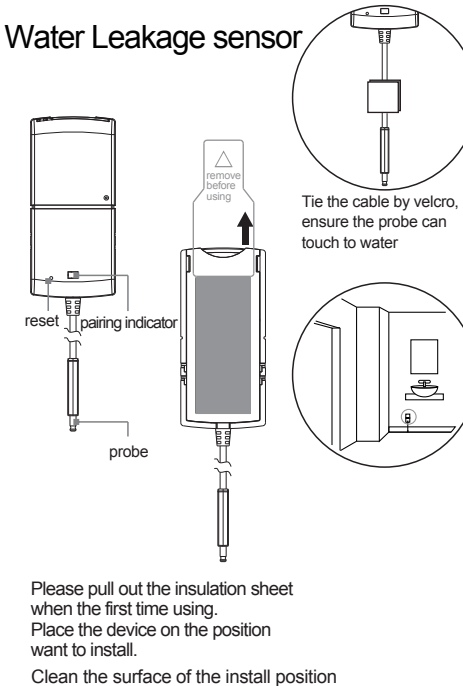

reset pairing indicator
probe
remove before using

Tie the cable by velcro, ensure the probe can touch to water

Please pull out the insulation sheet when the first time using. Place the device on the position want to install.
Clean the surface of the install position

Indoor sensor

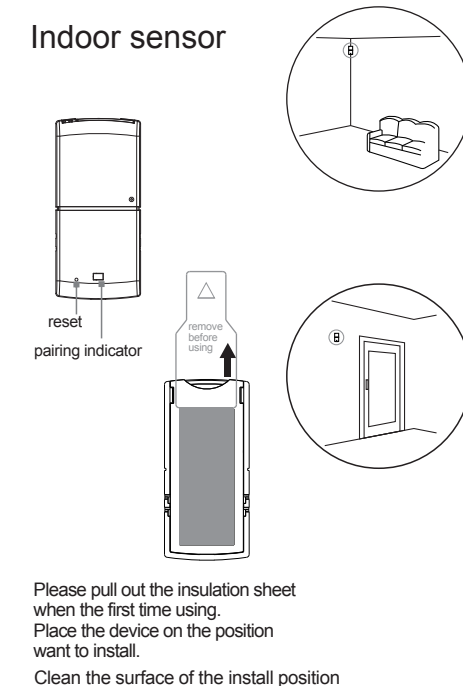

reset pairing indicator
remove before using

Please pull out the insulation sheet when the first time using. Place the device on the position want to install.
Clean the surface of the install position

Back side