

GNB

A division of

Exide Technologies

Industrial Battery Charger

Installation and Operation Manual

INDEX

Page	Section	Description
3	-	Safety Instructions
4	1.0	Installation
4	1.1	Receiving
4	1.2	Location
4	1.3	Line Voltage Adjustments
6	1.4	AC Service Requirements
6	1.5	Connecting AC Service to Charger
7	1.6	Grounding the Charger
7	1.7	Battery Connector and Charger Cable
7	1.8	Charging Rate Adjustment
8	2.0	Operation
8	2.1	046-0371 Control
13	3.0	Optional Features
13	4.0	Troubleshooting & Maintenance
15	5.0	Replaceable Parts
15	5.1	Ordering Information
15	5.2	Recommended Spares
16	5.3	Spare Parts List
17	6.0	Schematics

SAFETY INSTRUCTIONS

WARNING

THIS EQUIPMENT CONTAINS LETHAL VOLTAGE LEVELS. INSTALLATION AND SERVICING MUST BE PERFORMED BY QUALIFIED PERSONNEL

IMPORTANT: SAVE THESE INSTRUCTIONS!

READ AND FOLLOW ALL INSTRUCTIONS BEFORE INSTALLING, OPERATING, OR SERVICING CHARGER. ANY DEVIATION CAN CAUSE SERIOUS AND PERMANENT DAMAGE. FAILURE TO FOLLOW THE INSTRUCTIONS VOIDS THE WARRANTY.

1. Install and ground the charger in accordance with the National Electric Code and your local electric code. Failure to properly ground the charger could result in a fatal electric shock.
2. To reduce the risk of fire, install chargers on a surface of non-combustible material, such as concrete, stone, brick or grounded metal.
3. This charger has been designed to only charge flooded, lead-acid batteries. It should not be used for charging other types of flooded batteries or sealed batteries.
4. Connect only batteries of the same number of cells and ampere-hour rating as listed on the charger nameplate. Damage to the battery could occur, particularly if the battery has fewer cells than the rating of the charger.
5. Do not touch uninsulated parts of the output connector or battery terminals. A possibility of serious electrical shock exists.
6. During charge, batteries produce hydrogen gas, which can explode if ignited. Never smoke, use an open flame, or create sparks in the vicinity of the battery. Ventilate well when the battery is in an enclosed space.
7. Do not connect or disconnect the battery plug while the charger is on. Doing so will cause arcing and burning of the connector resulting in charger damage or battery explosion.
8. Lead-acid batteries contain sulfuric acid, which is caustic and can cause chemical burns to the skin. Refer to the battery manufacturers instructions for safe handling of batteries. Use proper personnel protective equipment. Do not get in eyes, on skin, or on clothing. In cases of contact with eyes, flush immediately with clean water for 15 minutes. Seek medical attention immediately.
9. Do not operate the charger with the door open or with any panels removed. De-energize all AC and DC power connections before servicing the charger.
10. The charger is not for outdoor use. Do not expose the charger to water spray, rain or snow.
11. Do not operate the charger with damaged cables, including cables with exposed conductors or damaged connectors. Replace damaged cables before operation.
12. Do not operate the charger if it has been dropped, received a sharp blow, or otherwise damaged in any way. Call your service representative.

SECTION 1 - INSTALLATION

1.1. Receiving

Immediately upon receipt of the charger, check it against the shipping invoice to ensure the shipment is complete and undamaged.

Examine the outside of the packing for signs of rough handling before accepting the charger from the carrier.

If there is evidence of damage, the receipt should be signed, and both copies (carrier's and receiving copies) marked "Shipment Received Damaged". The carrier's representative should be called immediately and asked to make a "Carrier's Damage Report".

If concealed damage is later detected, the carrier should be called and requested to make a "Carrier's Inspection for Concealed Damage Report".

After inspection by the carrier, arrangements should be made with the charger representative to have the charger repaired before placing it in service.

When contacting your charger representative for assistance on a damage claim or shipment error, provide the Model, and Serial Number of the charger, and a full description of the damage or error.

It is good practice to move the charger to the installation site before uncrating. When using bars, hammers, etc. for uncrating, use care to avoid damage to the charger.

WARNING: To reduce the risk of fire, install the battery charger on a non-combustible surface such as concrete, stone, brick, or steel. DO NOT operate the charger on its shipping skid materials.

1.2. Location

For the best operating conditions and longest life, take care in selecting an installation site. Avoid locations exposed to high humidity, temperature extremes or dust. Moisture condensing on machine parts and electrical components can cause corrosion, which seriously affects operation, efficiency and life. All units are designed for floor mounting. Standard cases may be stack-mounted if required, up to 3 high. If so, optional stacking brackets are required and available. Consult factory.

Dust and dirt will also decrease heat radiation from heat-generating components, such as transformers and diodes. This will result in higher operating temperatures and shorter life. Adequate air circulation is needed at all times in order to ensure proper operation. Provide a minimum of 6 inches of free air space at the sides and rear of the charger. The front of the charger must remain unobstructed for serviceability.

1.3. Line Voltage Adjustments

All chargers are shipped with the AC line voltage jumper wires set for the AC voltage specified on the purchase order. Before connecting the charger to the AC service, it should be verified that the internal AC voltage connections match the available AC service voltage. If necessary change the AC voltage jumper wires shown in Figs. 1.3.1 through 1.3.3.

NOTE: For 50 Hz. Single or three phase fixed voltage chargers, there are no adjustments.

CAUTION: It will be necessary in most cases to change the AC fuses when the AC voltage jumpers are changed. Refer to the fuse chart on the inside door of the charger for the correct fuse rating.

NOTE: When a 120/208/240 AC input unit is set for 120VAC a fuse neutral (brass tube) is required in the Line 2 (neutral) fuse position.

Fig. 1.3.1.
A.C. Voltage Adjustments
1 Ø 60Hz. (120/208/240)
"A" Voltage Code

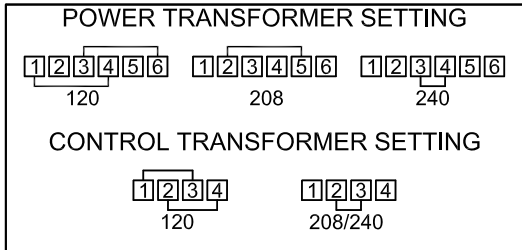

Fig. 1.3.2.
A.C. Voltage Adjustments
1Ø & 3Ø 60Hz. (208/240/480)
"B" Voltage Code

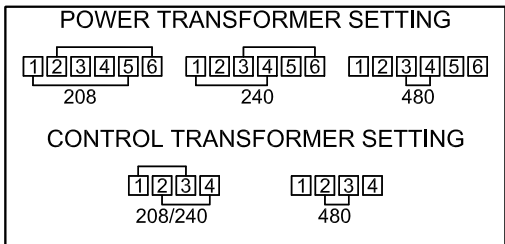
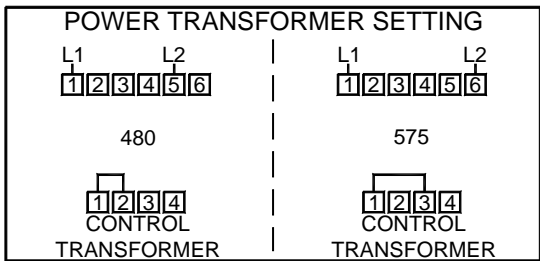

Fig.1.3.3.
A.C. Voltage Adjustments
3 Ø 60Hz. (480/575)
"K" Voltage Code



1.4. AC Service Requirements

Follow local code requirements if they are different than the instructions in this manual. After checking the transformer connections as described in Paragraph 1.3, refer to Table 1-1, to determine the correct ratings for the AC cable, AC fuses, and AC service disconnect switch for the line amperes as listed on the nameplate of the charger for the available AC voltage

Line Amperes	Disconnect Switch	Fuse Size Amps
000.0 - 02.5	30A	05
003.0 - 04.5	30A	07
005.0 - 07.5	30A	10
008.0 - 11.0	30A	15
011.5 - 15.5	30A	20
016.0 - 18.0	30A	25
018.5 - 22.0	30A	30
022.5 - 27.0	60A	35
027.5 - 32.0	60A	40
032.5 - 40.0	60A	50
040.5 - 48.0	60A	60
048.5 - 64.0	80A	80
065.0 - 80.0	100A	100
081.0 - 95.0	125A	125
096.0 - 125.0	150A	150

For voltages up to 240, use a 240 volt disconnect switch.

For voltages greater than 240 to 600, use a 600 volt disconnect switch.

- Two conductors and ground wire required for single phase.
- Three conductors and ground wire required for three-phase

1.5. Connecting AC Service to the Charger

1.5.1 Single-Phase Models

Connect the AC service to the L1 and L2 terminals located at the end of the AC fuse block.

Note: If the charger has been ordered with an AC input door-mounted disconnect switch, the AC input wires will be connected to the L1 and L3 terminals at the top of the switch body.

1.5.2 Three-Phase Models

Connect the AC service to the L1, L2 and L3 terminals located at the end of the AC fuse block.

Note: If the charger has been ordered with an AC input door-mounted disconnect switch, the AC input wires will be connected to the L1, L2 and L3 terminals at the top of the switch body.

1.6 Grounding the Charger

The charger must be grounded to the AC system ground for personnel safety.

The green ground wire in the AC input wiring must be connected to the charger ground stud (Identified by a green dot and ground symbol).

1.7 Battery Connector and Charging Cable

Verify that the connectors on both the battery and the charger are attached so that the positive output terminal of the charger is connected to the positive battery terminal.

**CAUTION: If the polarity is reversed, the DC fuse will blow.
If in doubt, check the polarity with a DC voltmeter.**

1.8 Charging Rate Adjustment

Note: Charging rate adjustments may be necessary to compensate for locations of extreme AC line variation or may be used to tailor the charger output for aging batteries.

The charging rate has been set at the factory; therefore, field adjustment should not be necessary.

If there appears to be a charging rate problem, refer to the troubleshooting chart, Section 4.

If it is necessary to either increase or decrease the charging rate, a rate adjustment terminal block is provided on the top rear of the transformer mounting bracket.

Change only one step at a time and observe the effect on the battery before making a second change.

The charging rate is increased by moving to the next higher tap setting in Table 1-2.

The charging rate is decreased by moving to the next lower tap setting.

No adjustments should be made without consulting the factory.

TABLE 1-2		
CHARGING RATE ADJUSTMENTS		
CONNECT RED JUMPER WIRE TO	CONNECT BLACK WIRE TO	OUTPUT
9	12	HIGHEST
9	11	
9	10	
9	8	NORMAL
12	11	
12	10	
12	9	LOWEST

SECTION 2 - OPERATION

The charger utilizes a standard ferro-resonant transformer, which provides isolation from the AC service line and regulates the charging current. The transformer output is connected to a full-wave bridge of silicon diodes, which provides DC charging current to the battery.

The starting charge amps and length of time required for a charge vary depending on the charger model. See the data plate on the charger for information.

2.1.1 046-0371 Control Feature Summary

- Charges flooded or sealed batteries.
- Automatic start when battery is connected or manual start (if selected).
- Automatic stop when charge is finished.
- Fully charges partially discharged batteries without overcharging.
- Dead battery 'jump start' for overly-discharged batteries.
- Equalize charge by user request or automatic equalize settable from 1-30 charges.
- Automatic refresh charging when set time has elapsed.
- Automatically resumes charge after a power failure (if auto-start selected).
- Displays charging amps and volts per cell during the charge cycle.
- End Voltage, end current, AH, and run time can be displayed during charge, at the end of charge, or after disconnecting the battery.
- Delayed start adjustable from 0 to 24 hours (if auto-start selected).
- Displays code if an abnormal charge indication is detected.
- Cool down timer after the charge is complete (if selected).

2.1.2 Description

The front panel has a 16 character LCD display which normally shows charging amps and volts per cell along with a periodic message showing the charger state. This display also presents messages if an abnormal charge indication is detected. A yellow 'Charging' indicator lights while the charger is charging. A green 'Complete' indicator lights when the charge is complete. A red 'Fault' indicator lights if an abnormal charge indication is detected.

The front panel has STOP, =, EDIT and INFO buttons. A charge can be stopped by pressing STOP and resumed by pressing STOP again. While charging, an equalize charge can be requested by pressing = and turned off by pressing =. During or after charge, the charge information may be obtained by pressing INFO.

2.1.3 Operation

The 046-0371 control is used in ferro-resonant taper chargers to provide fully automatic battery charging. The control has a charging profile that handles standard flooded lead-acid batteries. The charging profile, or algorithm, uniquely monitors the output current and voltage to optimally charge the battery, based on battery manufacturer's recommendations.

The control offers several safeguards to protect the battery. If a wrong voltage battery is connected, the charger does not start and a Low-Battery-Voltage (F3) or High-Battery-Voltage (F4) message is displayed. While charging, if the battery voltage exceeds a profile-specific cut-off value, the charge terminates with an end on voltage message.

2.1.4 Normal Daily Charge

When no battery is connected, the LED indicators are off and the LCD display shows '0A 0.00VC'. With the auto-start feature enabled, connecting a battery to the charger causes it to begin a charge cycle. The charger first performs a self-diagnostic test to verify the control is working properly. During this time a lamp test is performed causing all display segments and indicators to light. This allows the operator to

observe any defective segments or indicators. When the self-diagnostic is complete, the charge starts if no delay is set, and the yellow 'Charging' indicator lights. The display shows the charging amps and battery volts per cell along with a message to indicate the charger is in phase 1 of the charge cycle. If auto start is disabled, the display shows '**CHARGER OFF**'. Press STOP to manually start the charge.

When the battery is 80% charged, the charger starts phase 2 of the charge cycle.

When a charge is finished, the charger automatically turns off. The yellow 'Charging' indicator goes out. If cool down is enabled, the display shows the cool down time remaining. If cool down is disabled or the time has elapsed, the display shows '**0A x.xxVC**' along with a message indicating the battery is ready and the green 'Complete' indicator lights.

2.1.4.1 Disconnecting the Battery

Warning: Risk of explosion. Do not disconnect the battery while the charger is running. Hydrogen gas produced by the battery during charging can be ignited by arcing that occurs when the battery cable is disconnected.

If the battery must be disconnected before the end of the charge cycle, the charger should be turned off first. Press STOP, and verify the yellow 'Charging' indicator goes out. The LCD display shows '**CHARGER OFF**'. The battery may then be safely disconnected. If the green 'Complete' indicator is lit, the battery may be disconnected at any time.

2.1.5 Equalize Charge

Over time batteries can develop inequalities in cell charge. This can lower the effective capacity of the battery and shorten life. An equalizing charge re-balances the charge in the battery cells. Perform an equalize charge if any of the following conditions exist:

1. On flooded batteries the specific gravity of any cell at the end of charge is 20 points less than the average of all the cells.
2. The on-charge voltage of any cell at the end of charge is 20 millivolts less than the average of all the cells.
3. The battery has been stored for 30 days.

The 046-0371 control can perform an equalize automatically if auto equalize is enabled. Normal equalize consists of an additional 3 hour charge time at the end of a normal charge cycle. The 046-0371 control can also perform an equalize charge when requested manually. First connect the battery and allow the charge to start normally. Then press =. The display shows '=' on the left side and the charge time is extended by 3 hours to allow the cells to equalize their charge.

The auto-equalize or manual equalize cycle can be cleared by pressing = while in the normal charge cycle. The '=' indication on the display turns off. The next auto equalize charge occurs after the set number of charge cycles if auto equalize is enabled. If the set number of charge cycles have been completed, the charger attempts to equalize after the next charge cycle and continues to attempt to equalize until an equalize cycle has completed.

The default setting for automatic equalize is every 7 cycles. To change the number of charge cycles for automatic equalize, refer to the programming section.

2.1.6 Delayed Start

The delayed-start feature allows the operator to delay starting the charge cycle. This might be desired to reduce peak energy surcharges if the charger were ready to start during a peak energy period. The delay time could be set to keep the charger from starting until after the peak period ends.

To view or change the delayed start setting, refer to the programming section.

2.1.7 Auto- Refresh Charge

The 046-0371 control can provide an auto-refresh charge as long as the battery remains connected to the charger if enabled. If AC power is lost during the wait period, the control resumes from where it left off after power is restored. During the auto-refresh charge, the amp-hours and charge time are added to the original charge. The refresh charge consists of 30 minutes at the equalize current. To change the auto-refresh settings, refer to the programming section.

2.1.8 Viewing Charge Information

Additional charge information is available any time by pressing the INFO button. This information is retained after the battery is disconnected until the next battery is connected. After 20 seconds the display returns to the default display of amps and volts per cell. The following information can be viewed:

Parameter	DISPLAY	DESCRIPTION
Charger State	XXXXXX	Message describing charger state.
Amps	CHARGER DC AMPS AA: xxxA	Charger current in amps.
Volts/Cell	BATTERY V/C VC: x.xxVC	Battery voltage in volts per cell (v/c).
Amp Hours	ACCUMULATED AH AH: xxxxAH	Amp Hours returned for the current (or last) charge cycle.
Charge Time	CHARGE TIME TC: xx:xxHM	Charge time for the current (or last) charge cycle in hours and minutes.
Percent Return	% AH RETURNED PR: xxx%	Percent of Amp Hours returned as a function of battery AH rating.
Voltage	BATTERY VOLTS VV: xx.xV	Total battery voltage in volts.
End Current	CHARGE END AMPS EA: xxxA	End current for the last charge cycle (current amps if charging)
End Voltage	CHARGE END VOLTS EV: x.xxVC	End voltage for the last charge cycle (current voltage if charging)
Software	SOFTWARE VERSION SW: x.xx	Control software version

2.1.9 Charge Indications

The following indications are not necessarily a result of a charger problem. They are typically caused by external problems such as AC line, poor battery conditions, connections, etc. If abnormal charge conditions are detected, the charge is terminated, the red fault LED lights and the display shows:

DISPLAY	DESCRIPTION	POSSIBLE CAUSE
F0 SHORTED CELL ###VC ##:##HM	Battery voltage did not reach 2.00 V/C within 30 minutes. ###VC is the volts per cell at end of charge and ##:##HM is the charge time.	<ul style="list-style-type: none"> - Shorted Cell - Open diode - Low Charging amps - Low AC line voltage - Wrong size battery - Battery over-discharged
F1 SHORTED CELL ###VC ##:##HM	Battery did not reach gassing voltage within the allowable time. ###VC is the volts per cell at end of charge and ##:##HM is the charge time.	<ul style="list-style-type: none"> - Shorted Cell - Open diode - Low Charging amps - Low AC line voltage - Wrong size battery - Battery over-discharged
F3 LOW VOLTS ###A ###VC	Low battery voltage, less than 1.60 V/C at start up. ###A is the charger current and ###VC is the battery volts per cell.	<ul style="list-style-type: none"> - Wrong size battery - Battery over-discharged - Voltage jumper setting incorrect
F4 HIGH VOLTS ###A ###VC	High battery voltage, more than 2.40 V/C at start up. ###A is the charger current and ###VC is the battery volts per cell.	<ul style="list-style-type: none"> - Wrong size battery - Battery fully charged - Voltage jumper setting incorrect
F5 NO DC CURRENT ###A ###VC	No charging current to the battery. ###A is the current at the end of charge and ###VC is the volts per cell at end of charge.	<ul style="list-style-type: none"> - Faulty AC line contactor - Open diode - Faulty resonant capacitor - Poor battery connections - Open cell - Faulty control board
F6		<ul style="list-style-type: none"> - Incorrect control setup
F7 LONG CHARGE ###VC ##:##HM	Long charge, the charger ran longer than the allowed time. ###VC is the volts per cell at end of charge and ##:##HM is the charge time.	<ul style="list-style-type: none"> - Open diode - Low Charging amps - Low AC line voltage - Wrong size battery - Battery over-discharged
F8 CHARGER ON ###A ###VC	Charger stayed on when control requested it to shut off. ###A is the charger current and ###VC is the battery volts per cell.	<ul style="list-style-type: none"> - AC line contactor stuck on - Open shunt sense lead or loose connection - Incorrect control setup - Missing or damaged current sensor - Faulty control board
F9 BAD KEYPAD ###A ###VC	Faulty keypad detected. One or more buttons are stuck on. ###A is the charger current and ###VC is the battery volts per cell.	<ul style="list-style-type: none"> - Faulty keypad - Faulty control board
F10 HIGH CURRENT ###A ###VC	Charging current exceeds 110% of shunt setting. ###A is the current at the end of charge and ###VC is the volts per cell at end of charge.	<ul style="list-style-type: none"> - High charging amps or high AC line voltage - Missing or damaged current sensor - Incorrect shunt size - Open shunt sense lead or loose connection - Faulty control board

Note: F3 and F4 clear automatically if the battery voltage falls within acceptable limits. All indications except F8, F9 and F10 can be cleared by disconnecting the battery. For F8, F9 and F10, correct the condition that caused the indication and disconnect the battery to clear the indication.

CAUTION: If F8 is showing, and the charger is providing current to the battery, remove AC power from the charger before disconnecting the battery.

2.1.10 F3 (Low Battery) Override

If battery voltage is below 1.60 volts per cell the charger does not start automatically. If this is due to an overly discharged battery of the correct voltage, the F3 indication can be manually overridden by pressing 'STOP' while the F3 message (Low Battery) displays.

2.1.11 Jumper Settings

CAUTION: Remove AC and DC power from the charger before changing any jumper settings. Refer to figure 1 for location of jumpers.

- Jumper J5 should be set to match the battery voltage.

- Volts
- 80V
- 72V
- 64V
- 48V
- 36V
- 24V
- 12V¹
- SP²

¹For non-standard battery voltages above 80V, the jumper is set on 12 and a resistor is installed in the charger wire harness based on the following calculation: $R = 1250 \times (\text{Nominal Battery Voltage}) - 15000$.

²For non-standard battery voltages between 12V and 80V, the jumper is set on SP and resistor R9 is installed on the control based on the following calculation: $R9 = 1250 \times (\text{Nominal Battery Voltage}) - 15000$.

- Jumper J4 is used to lock out several parameters in the programming mode.
- Header J1 is used to select the charger type.

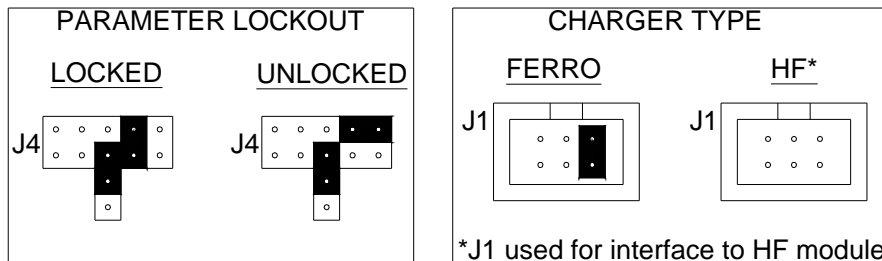

Caution: Placing jumpers on any other position on J1 or J4 may damage the control and voids the warranty.

2.1.12 Programming

To enter programming mode, press and hold the EDIT button and while holding it, press the INFO button. The display shows a message describing the current parameter followed by the parameter's value. While in programming mode, the buttons have the following functions:

STOP: Exit programming mode and save all parameters

=: Shift position of parameter being edited

EDIT: Change value of current position of parameter being edited

INFO: Change parameter to edit

Some of the parameters may be locked out in the programming mode. If a parameter is locked, the parameter is displayed along with the current value and a lock is displayed on the left side of the display. The parameter can not be changed. Refer to jumper settings section for information on locking out parameters. The following parameters are available for editing:

PARAMETER	MESSAGE	RANGE	NOTES	LOCK
BS	BATTERY AH SIZE	100-2200AH		
VR	BATTERY VOLTAGE	12-999V		•
SR	SHUNT RATING	0-600A	A setting of 0 enables current sensor operation	•
AS	AUTO START MODE	0-2	0: Manual Start 1: Auto-Start 2: Auto Start (restart on AC power)	
CR	CABLE RESISTANCE	0-25mΩ		
SA	START A/100AH	5.0-50.0 A/100AH		•
TP	80% TRIP POINT	2.35-2.45 V/C		•
FA	FINISH A/100AH	0.1-10.0 A/100AH		•
FV	FINISH VOLTAGE	2.50-3.00 V/C		•
CV	CUTOFF VOLTAGE	2.50-3.00 V/C	Exceeding this voltage terminates the charge immediately.	•
ST	80% TIMEOUT	0:00-24:00	Exceeding this time results in an F1 if F1 is enabled and ends normally if F1 is disabled. (see N1 parameter)	•
FT	CHARGE TIMEOUT	0:00-24:00	Exceeding this time results in an F7 if F7 is enabled and ends normally if F7 is disabled. (see N7 parameter)	•
MP	MAX POWER RATING	0.1-25.0 kW	*DO NOT EXCEED RATING OF CHARGER	•
CF	CHARGE FACTOR	0-150%	Maximum return based on battery AH size. Setting this to 0 disables the charge factor.	•
DS	DELAY START TIME	0:00-24:00		
CT	COOL DOWN TIME	0:00-24:00		
CU	DVDT PERIODS	0-15	Each period is 5 minutes. Setting this to 0 causes the charge to terminate when the trip point is reached. (opportunity charge)	•
EM	EQUALIZE MODE	0-1	0: Equalize disabled 1: Normal equalize	•
EI	EQUALIZE A/100AH	0.1-10.0 A/100AH		•
ET	EQUALIZE TIME	0:00-24:00		•
EC	EQUALIZE CYCLES	0-30	Setting this to 0 disables automatic equalize.	
N1	F1 FAULT DISABLE	0-1	0: Enabled, 1: Disabled	•
N3	F3 FAULT DISABLE	0-1	0: Enabled, 1: Disabled	•
N4	F4 FAULT DISABLE	0-1	0: Enabled, 1: Disabled	•
N6	F6 FAULT DISABLE	0-1	0: Enabled, 1: Disabled	•
N7	F7 FAULT DISABLE	0-1	0: Enabled, 1: Disabled	•
AR	REFRESH TIME	00:00-72:00	Setting this to 0:00 disables automatic refresh.	

SECTION 3 - OPTIONAL FEATURES

3.1 Fusible Door-Interlock Switch (JIC Switch)

The door interlock switch assembly connects the AC service to the charger's input fuses for each AC line. The switch is mechanically latched by the door so that it must be in the OFF position before the door can be opened. Operation of the charger is identical to that of the standard model, except the charger cannot be energized if the door is open.

3.2 Remote Control

The remote control option makes it possible to operate the charger at a point within 15 feet of the charger. It includes a box equipped with the control option ordered, and 15, 20, or 30 feet of jacketed control harness. Operation is identical to that of a standard charger except that the control is not mounted on the front of the charger.

3.3 Watering Valve

On chargers ordered with the 046-0172 control, an optional 24VAC watering solenoid can be ordered. The valve will activate at the end of the charge cycle. It works in conjunction with an automatic watering system that is supplied by others. Note: Watering valves have a one year part replacement warranty only.

3.4 Charger Stand

The charger stand is a metal frame that is designed to bolt the charger cabinet on top of it. It raises the cabinet up to the operator's level, rather than having the cabinet sitting on the floor.

SECTION 4 – TROUBLESHOOTING & GENERAL MAINTENANCE

Caution: There are lethal voltages exposed when the charger is energized with the door open. Always disconnect the AC service voltage to the charger before opening the door. The following chart lists the most probable cause of a malfunction.

SYMPTOMS AND POSSIBLE CAUSES

4.1. No charging current, the control has no display, contactor does not operate.

POSSIBLE CAUSE

- A. Blown AC fuse.
- B. No AC service voltage.
- C. Incorrect AC voltage.
- D. Control transformer output fuse blown.
- E. Defective control transformer.
- F. Defective control board.

4.2. No charging current, control has a display.

POSSIBLE CAUSE

- A. Blown DC fuse.
- B. Defective ammeter.
- C. Open battery cell.
- D. Defective diode.
- E. Defective capacitor.
- F. Shorted power transformer secondary.

4.3. AC fuse blows.

POSSIBLE CAUSE

- A. Incorrect fuse rating.
- B. Incorrect AC voltage.
- C. Fuse Block holding clips loose.
- D. Shorted transformer winding.

4.4. DC fuse blows.

POSSIBLE CAUSE

- A. Reversed battery connector.
- B. Incorrect fuse rating.
- C. Shorted diode.

4.5. Excessive water loss in battery.

POSSIBLE CAUSE

- A. Charging rate is too high. See Section 1.8.
- B. Charger amp-hour rating exceeds the battery amp-hour rating.
- C. Battery has defective cells.

4.6. Low specific gravity at the end of the charge cycle.

POSSIBLE CAUSE

- A. Battery was over-discharged.
- B. Charger amp-hour rating is less than the battery AH rating.
- C. Defective open diode.
- D. Charging rate is too low. See Section 1.8.
- E. Battery has defective cells.
- F. Battery has been over-watered.

4.7. Charger does not turn off when the control terminates the charge cycle.

POSSIBLE CAUSE

- A. Defective control.
- B. AC contactor has welded contacts.

4.8. General Maintenance

The charger requires a minimum of maintenance. Connections and terminals should be kept clean and tight. The charger should be periodically cleaned with an air hose to prevent any excessive dirt build up on components. Care should be taken not to bump or move any adjustments during cleaning. Make sure that both the AC lines and the battery are disconnected before cleaning. The frequency of this type of maintenance depends on the environment in which this unit is installed. If any cabinet sheet metal panels are removed for cleaning, be certain they are properly reinstalled upon completion.

SECTION 5 – REPLACEABLE PARTS

5.1 Ordering Information

The following information must be supplied when ordering a replacement part from your service agent in order to ensure that the correct part is supplied:

- A. Model or Spec. number of charger (Located on charger data plate)
- B. Serial number of charger (Located on charger data plate)
- C. Schematic reference symbol or part
- D. Description of part

5.2 Recommended Spares

The quantity of spares stocked should be increased as the number of chargers increases.

The following chart is the minimum quantity recommended per model for multiple charger installations:

<u># OF CHARGERS</u>	<u># OF SPARE PARTS KITS</u>
1-3	1
4-10	2
11-25	3
26-50	4
51-100	5

<u>SCHEMATIC REF SYMBOL</u>	<u>DESCRIPTION</u>	<u>QUAN. USED</u>	<u>QUANTITY RECOMMENDED</u>
ACF	AC FUSE, 1 PH.	2	4
ACF	AC FUSE, 3 PH.	3	6
DCF	DC FUSE	1	2
CONTROL	CONTROL BOARD	1	1
AK	A.C. CONTACTOR	1	1
SD1,SD2	SILICON DIODE, 1 PH.	2	2
SD1-SD6	SILICON DIODE, 3 PH.	6	3
TP	TRANSFORMER, 1 PH.	1	0
TP	TRANSFORMER, 3 PH	3	0
C	CAPACITOR	VARIES	1
CT	CONTROL TRANSFORMER	1	1

5.3 Spare Parts List

<u>Part Number</u>	<u>Description</u>
<u>Condensers</u>	
008-0002	2 MFD 440 Volt
008-0004	4 MFD 440 Volt
008-0006	6 MFD 440 Volt
008-0008	8 MFD 440 Volt
008-0010	10 MFD 440 Volt
008-0012	12.5 MFD 440 Volt
008-0015	15 MFD 440 Volt
008-0017	17.5 MFD 440 Volt
008-0020	20 MFD 440 Volt
008-0030	30 MFD 440 Volt
008-0040	40 MFD 440 Volt
<u>Resistors</u>	
037-0017	1.25 Ohm 100 Watt
037-0018	1.25 Ohm 200 Watt
037-0015	2.50 Ohm 100 Watt
037-0010	2.50 Ohm 200 Watt
<u>Diodes</u>	
024-0001	70 A 600 Volt
024-0003	150 A 600 Volt
<u>Contactors</u>	
A09-0020	30 Amp 3 Pole
A09-0021	30 Amp 2 Pole
A09-0049	60 Amp 3 Pole
<u>Controls</u>	
P46-371	4 Button control
<u>Control Transformers</u>	
A03-1210	240/480P, 24S, 50 VA
A03-1211	120/240P, 24S, 50 VA
A03-1213	480/600P, 24S, 50 VA
<u>DC Fuses</u>	
011-0243	80 Amp, 130 Volt
011-0044	100 Amp, 130 Volt
011-0045	150 Amp, 130 Volt
011-0046	200 Amp, 130 Volt
011-0047	250 Amp, 130 Volt
011-0048	300 Amp, 130 Volt
011-0049	400 Amp, 130 Volt

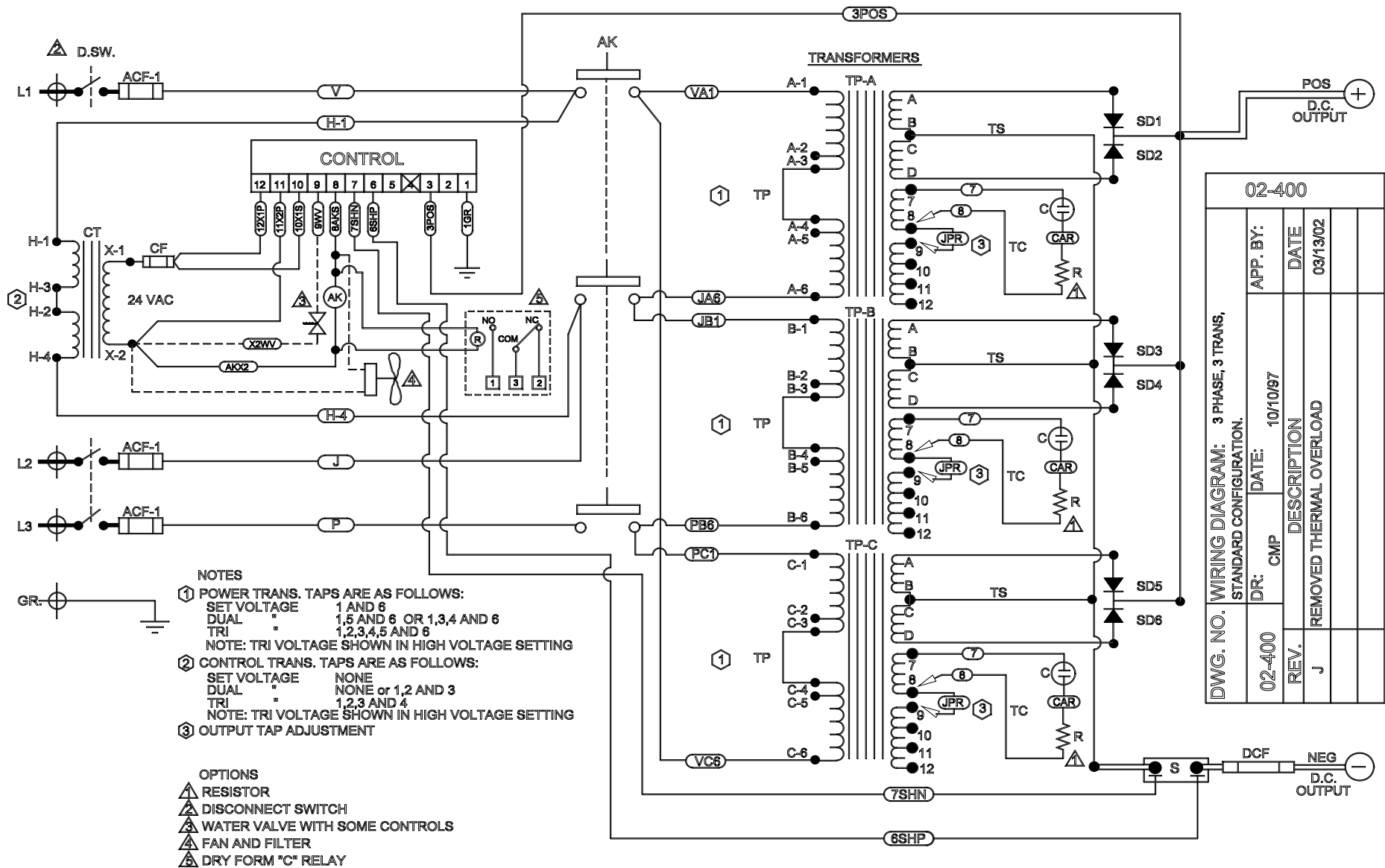

02-400

DWG. NO. WIRING DIAGRAM: 3 PHASE, 3 TRANS, STANDARD CONFIGURATION.		APP. BY:	DATE:	DESCRIPTION:
02-400	DR: CMP	10/10/97	REMOVED THERMAL OVERLOAD	
REV. J				

Three Phase Charger Schematic # 02-400

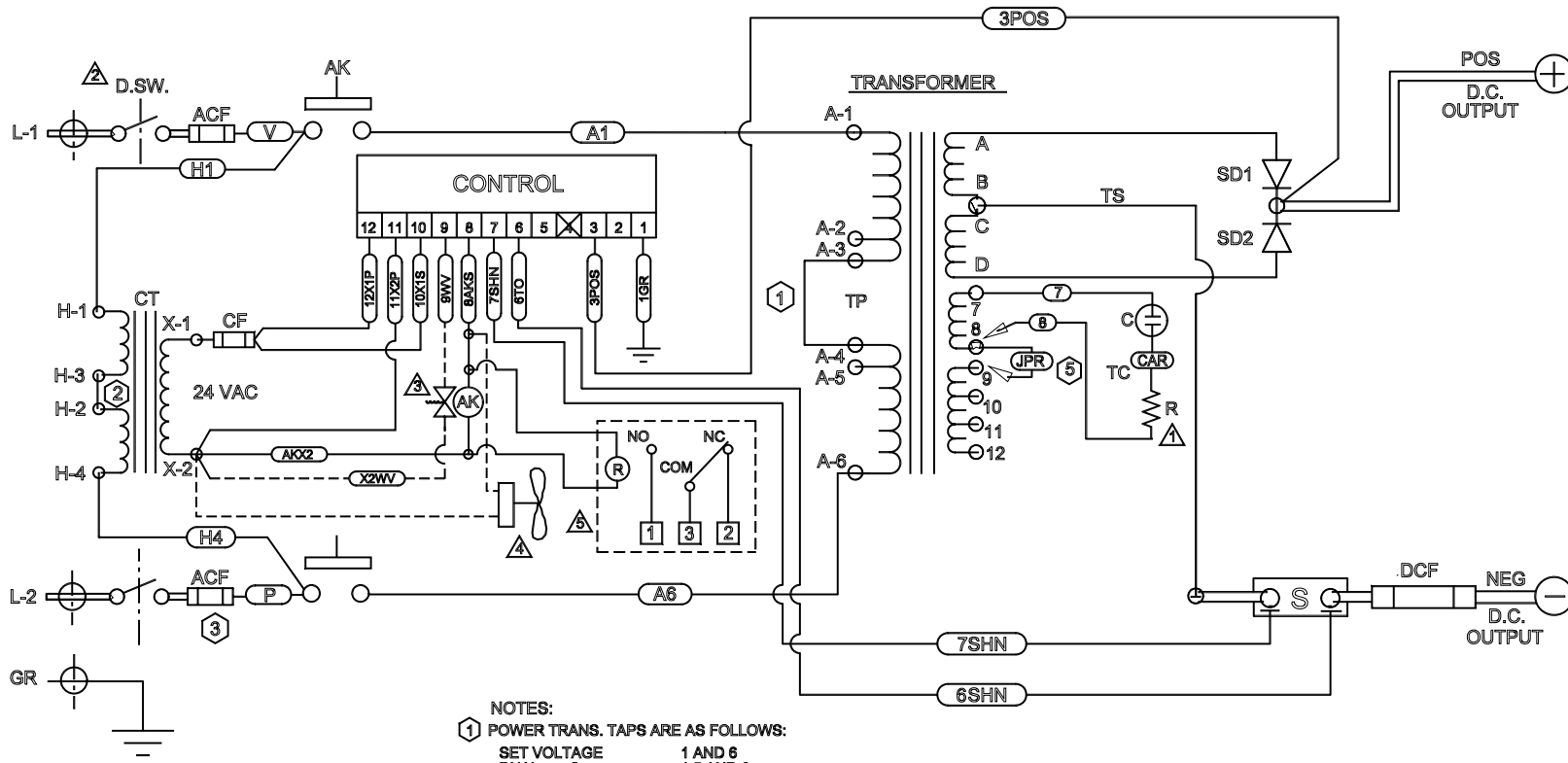

- OPTIONS:
- ① RESISTOR
 - ② DISCONNECT SWITCH
 - ③ WATER VALVE WITH SOME CONTROLS
 - ④ FAN AND FILTER
 - ⑤ DRY FORM "C" RELAY - OPTIONAL

- NOTES:
- ① POWER TRANS. TAPS ARE AS FOLLOWS:
 SET VOLTAGE 1 AND 6
 DUAL " 1,5 AND 6
 TRI " 1,2,3,4,5 AND 6
 NOTE: TRI VOLTAGE SHOWN IN HIGH VOLTAGE SETTING
 - ② CONTROL TRANS. TAPS ARE AS FOLLOWS:
 SET VOLTAGE NONE
 DUAL " NONE OR 1,2 AND 3
 TRI " 1,2,3 AND 4
 NOTE: TRI VOLTAGE SHOWN IN HIGH VOLTAGE SETTING
 - ③ FOR 120V OPERATION, INSTALL A DUMMY FUSE IN LINE 2. CONNECT THE NEUTRAL INPUT LEAD TO LINE 2.
 - ④ TRANSFORMER THERMAL OVERLOAD
 - ⑤ OUTPUT TAP ADJUSTMENT

DWG. NO.	WIRING DIAGRAM: 1 PHASE, 1 TRANS			02-416
02-416	STANDARD CONFIGURATION.			
REV	DR:	DATE:	APP'VD BY:	
1	CMP	10/15/97		
	DESCRIPTION			DATE
	REMOVED THERMAL OVERLOAD			3/13/02

Single Phase Charger Schematic # 02-416

(C1,C2,C3 AND C4) TYPICAL CIRCUIT

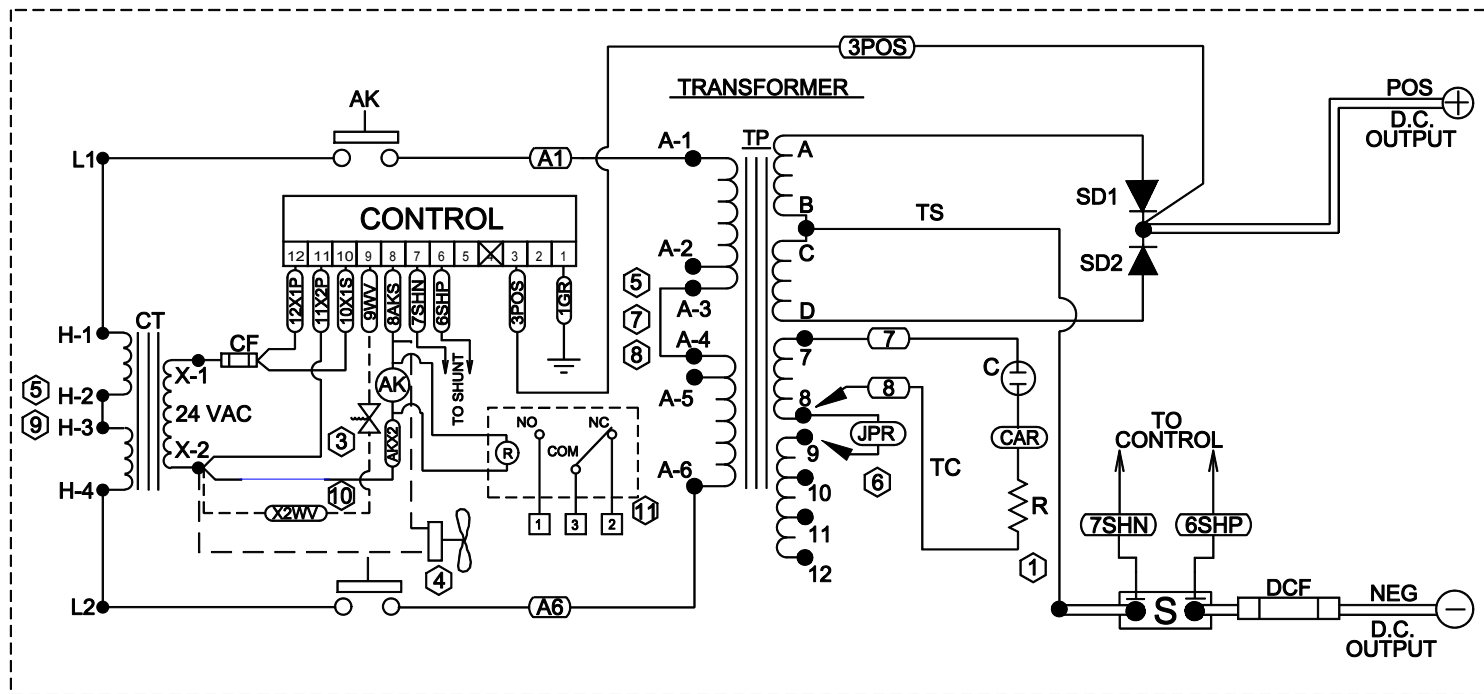
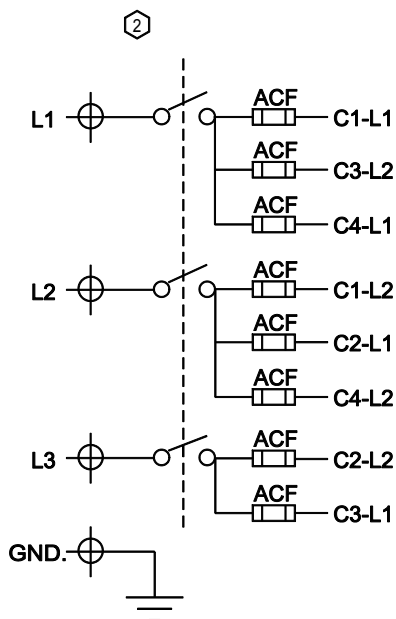

NOTES:

- ① RESISTOR OPTIONAL
- ② DISCONNECT OPTIONAL
- ③ WATER VALVE OPTIONAL
- ④ FAN AND FILTER OPTIONAL
- ⑤ SHOWN IN HIGH VOLTAGE SETTING
- ⑥ OUTPUT TAP ADJUSTMENT
- ⑦ MODELS WITH DUAL VOLTAGE PRIMARY'S WILL ONLY HAVE 1,5 AND 6 TAPS
- ⑧ MODELS THAT HAVE A SET VOLTAGE WILL ONLY HAVE 1 AND 6 TAPS
- ⑨ MODELS THAT HAVE DUAL VOLTAGE OR SET VOLTAGE MAY HAVE A SET VOLTAGE CONTROL TRANSFORMER
- ⑩ TRANSFORMER THERMAL OVERLOAD
- ⑪ DRY FORM "C" RELAY - OPTIONAL

#-# DENOTES POSITION ON 4 POLE TERMINAL BLOCK

* WATERING NOT AVAILABLE ON ALL CONTROLS.

DWG. NO.	WIRING DIAGRAM: 3 PHASE, 4 TRANS, 4 GANG, STANDARD CONFIGURATION.			02-490
02-490	DR. CMP	DATE: 01/08/98	CHK:	
REV.	DESCRIPTION			DATE
D	REMOVED THERMAL OVERLOAD			01/08/05