

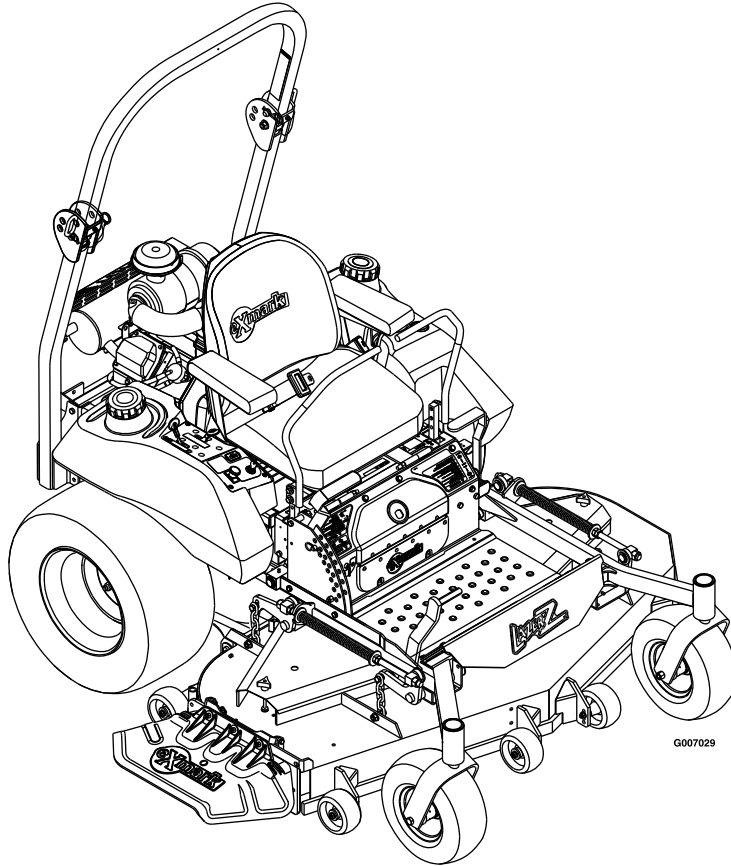

For Serial Nos.
720,000 & Higher

OPERATOR'S MANUAL



LAZER Z[®] LZ27KC604 MODEL ONLY

Place Model No. and Serial No.
Label Here (Included in the Literature
Pack) or Fill in Below

Model No. _____

Serial No. _____

Date Purchased _____

Engine Model No. and Spec. No. _____

Engine Serial No. (E/No) _____

⚠ WARNING

CALIFORNIA Proposition 65 Warning

The engine exhaust from this product contains chemicals known to the State of California to cause cancer, birth defects, or other reproductive harm.

Important: When the mower is used or operated on any California forest, brush or grass covered land, a working spark arrester must be attached to the muffler. If not, the operator is violating state law, Section 4442 Public Resource Code. To acquire a spark arrester for your unit, see your Engine Service Dealer.

This spark ignition system complies with Canadian ICES-002 Ce système d'allumage par étincelle de véhicule est conforme à la norme NMB-002 du Canada

The enclosed Engine Owner's Manual is supplied for information regarding The U.S. Environmental Protection Agency (EPA) and the California Emission Control Regulation of emission systems, maintenance and warranty.

Keep this engine Owner's Manual with your unit. Should this engine Owner's Manual become damaged or illegible, replace immediately. Replacements may be ordered through the engine manufacturer.

Exmark reserves the right to make changes or add improvements to its products at any time without incurring any obligation to make such changes to products manufactured previously. Exmark, or its distributors and dealers, accept no responsibility for variations which may be evident in the actual specifications of its products and the statements and descriptions contained in this publication.

EXMARK PARTS PLUS[®] PROGRAM

EFFECTIVE DATE: September 1, 1995

Program

If your Exmark dealer does not have the Exmark part in stock, Exmark will get the parts to the dealer the next business day or the part will be FREE* Guaranteed!!



How the Program Works

1. If dealer does not have part in stock for a "down" unit at the time of request by customer, the dealer contacts his distributor by 1:00 p.m., local time, and requests Exmark Parts Plus[®] shipment of six (6) line items or less.
2. Distributor ships part(s) to dealer or customer, as requested by dealer, same day, overnight UPS. Distributor bills dealer for part and freight charges where applicable.
3. If distributor does not have the part(s) in stock to satisfy Exmark Parts Plus[®] order, he contacts Exmark by 3:00 p.m., central time, with an Exmark Parts Plus[®] order of six (6) line items or less.
4. If order is received by 3:00 p.m. central time, Exmark ships part(s) direct to dealer or customer, as requested by distributor, same day, overnight UPS, Exmark bills the distributor for parts and shipping charges, where applicable.
5. The customer pays for the part and freight if it is shipped under the Exmark Parts Plus[®] and if it arrives in accordance to the program.
6. Who pays for the part and freight if it fails to arrive overnight in accordance to the program?
 - A. Under any circumstance the customer does not pay.
 - B. If the part does not arrive overnight due to:
 1. The dealer not submitting the Exmark Parts Plus[®] order to his Exmark distributor by 1:00 p.m., the dealer pays for the part and freight.
 2. The Distributor being unable to ship the part the same day or not submitting the Exmark Parts Plus[®] order to Exmark by 3:00 p.m., central time, the Distributor pays for the part and freight.
 3. Exmark being unable to ship the part and the Exmark parts order is received by 3:00 p.m., central time, Exmark pays for the part and freight.
 4. If the part does not arrive overnight due to the shipper (UPS), the shipper pays for the freight and Exmark pays for the part.

* The following restrictions apply -- The Exmark Parts Plus[®] Program is available only through participating Exmark Dealers and applies only to orders submitted on this program Monday through Thursday. Parts Plus service is available only in the 48 contiguous United States. UPS has initiated a Saturday delivery program to many areas of the continental United States and can be requested for an overnight shipment on Friday to be delivered Saturday. The next day air charge, plus the Saturday delivery fee will be the responsibility of the purchaser. Exmark Mfg. will assume no responsibility for Saturday delivery shipments. To qualify, all Exmark Parts Plus[®] orders must be received by Exmark by 3:00 p.m., central time. Orders must be six (6) line items or less. Exclusions from the Exmark Parts Plus[®] Program are: Any wholegood or accessory in its entirety, engines and engine replacement parts, 5-speed Peerless transmissions and 5-speed transaxles, hydraulic or hydrostatic wheel motors, cutter decks and engine decks or any item exceeding United Parcel Service size and weight restrictions.

Due to UPS restrictions, aerosol spray paint is considered a hazardous material and cannot be shipped via UPS next day or Second Day Air.

Exmark Manufacturing stocks a limited supply of parts for transaxles, pumps and wheel motors. These parts can be ordered for Next Day Air shipment but will not be guaranteed per the Parts Plus Program.

Introduction

CONGRATULATIONS on the purchase of your Exmark Mower. This product has been carefully designed and manufactured to give you a maximum amount of dependability and years of trouble-free operation.

This manual contains operating, maintenance, adjustment, and safety instructions for your Exmark mower.

BEFORE OPERATING YOUR MOWER, CAREFULLY READ THIS MANUAL IN ITS ENTIRETY.

By following the operating, maintenance, and safety instructions, you will prolong the life of your mower, maintain its maximum efficiency, and promote safe operation.

If additional information is needed, or should you require trained mechanic service, contact your authorized Exmark equipment dealer or distributor.

All Exmark equipment dealers and distributors are kept informed of the latest methods of servicing and are equipped to provide prompt and efficient service in the field or at their service stations. They carry ample stock of service parts or can secure them promptly for you from the factory.

All Exmark parts are thoroughly tested and inspected before leaving the factory, however, attention is required on your part if you are to obtain the fullest measure of satisfaction and performance.

Whenever you need service, genuine Exmark parts, or additional information, contact an Authorized Service Dealer or Exmark Customer Service and have the model and serial numbers of your product ready.

Figure 1 identifies the location of the model and serial numbers on the product. Write the numbers in the space provided.

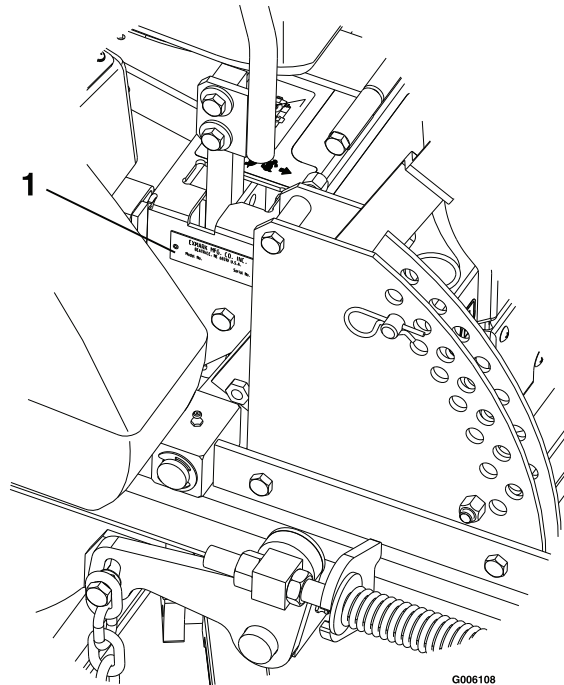

Figure 1

1. Model and serial number location

Model No. _____
Serial No. _____

Contents

Introduction	4	Deck Leveling	33
Safety	6	Pump Drive Belt Tension.....	34
Safety Alert Symbol.....	6	Mule Drive Belt Tension Adjustment	34
Safe Operating Practices	6	Deck Belt Tension	35
Safety and Instructional Decals	11	Belt Guide Adjustment.....	35
Specifications	15	Brake Link Adjustment.....	35
Model Numbers	15	Brake Adjustment.....	35
Systems	15	Electric Clutch Adjustment.....	36
Dimensions.....	16	Reverse Indicator Adjustment.....	36
Torque Requirements	17	Motion Control Linkage Adjustment	36
Product Overview	17	Motion Control Damper Adjustment.....	37
Operation	18	Adjust Seat Switch	38
Controls	18	Caster Pivot Bearings Pre-Load	
Pre-Start.....	19	Adjustment	38
Operating Instructions	19	Cleaning	39
Transporting	23	Clean Engine Cooling System	39
Maintenance	25	Remove Engine Shrouds and Clean Cooling	
Recommended Maintenance Schedule(s)	25	Fins	39
Periodic Maintenance	26	Clean Grass Build-Up Under Deck	39
Check Engine Oil Level	26	Waste Disposal.....	39
Check Battery Charge	26	Troubleshooting	41
Check Mower Blades	27	Schematics	43
Check Safety Interlock System	27		
Check Rollover Protections Systems (Roll			
Bar) Pins	28		
Check Seat Belt.....	28		
Check for Loose Hardware	28		
Service Air Cleaner.....	28		
Change Engine Oil.....	29		
Check Hydraulic Oil Level	29		
Check Tire Pressures	29		
Check Condition Of Belts.....	29		
Lubricate Grease Fittings.....	29		
Lubricate Caster Wheel Hubs	30		
Lubricate Brake Handle Pivot	31		
Lubricate Brake Rod Bushings	31		
Lubricate Motion Control Bronze			
Bushings	31		
Lubricate Seat Switch Actuator	31		
Check Spark Plugs.....	31		
Change Hydraulic System Filter	32		
Wheel Hub - Slotted Nut Torque			
Specification.....	32		
Thread Locking Adhesives.....	32		
Mobil HTS Grease (Or Food-Grade			
Anti-seize).....	33		
Copper-Based Anti-seize	33		
Dielectric Grease.....	33		
Adjustments	33		

Safety

Safety Alert Symbol

This Safety Alert Symbol (Figure 2) is used both in this manual and on the machine to identify important safety messages which must be followed to avoid accidents

This symbol means: **ATTENTION! BECOME ALERT! YOUR SAFETY IS INVOLVED!**



Figure 2

1. Safety alert symbol

The safety alert symbol appears above information which alerts you to unsafe actions or situations and will be followed by the word **DANGER**, **WARNING**, or **CAUTION**.

DANGER: White lettering / Red background. Indicates an imminently hazardous situation which, if not avoided, **Will** result in death or serious injury.

WARNING: Black lettering / Orange background. Indicates a potentially hazardous situation which, if not avoided, **Could** result in death or serious injury.

CAUTION: Black lettering / Yellow background. Indicates a potentially hazardous situation which, if not avoided, **May** result in minor or moderate injury.

This manual uses two other words to highlight information. **Important** calls attention to special mechanical information and **Note** emphasizes general information worthy of special attention.

Safe Operating Practices

Training

- Read the Operator's Manual and other training material. If the operator(s) or mechanic(s) can not read English it is the owner's responsibility to explain this material to them.
- Become familiar with the safe operation of the equipment, operator controls, and safety signs.
- All operators and mechanics should be trained. The owner is responsible for training the users.

- Never let children or untrained people operate or service the equipment. Local regulations may restrict the age of the operator.
- The owner/user can prevent and is responsible for accidents or injuries occurring to himself or herself, other people or property.

Preparation

- Evaluate the terrain to determine what accessories and attachments are needed to properly and safely perform the job. Only use accessories and attachments approved by Exmark.
- Wear appropriate clothing including safety glasses, substantial footwear, long trousers, and hearing protection. Do Not operate when barefoot or when wearing open sandals. Long hair, loose clothing or jewelry may get tangled in moving parts.

⚠ CAUTION

This machine produces sound levels in excess of 85 dBA at the operator's ear and can cause hearing loss through extended periods of exposure.

Wear hearing protection when operating this machine.

- Inspect the area where the equipment is to be used and remove all rocks, toys, sticks, wires, bones, and other foreign objects which can be thrown by the machine and may cause personal injury to the operator or bystanders.

⚠ DANGER

In certain conditions gasoline is extremely flammable and vapors are explosive.

A fire or explosion from gasoline can burn you, others, and cause property damage.

- Fill the fuel tank outdoors in an open area, when the engine is cold. Wipe up any gasoline that spills.
- Never refill the fuel tank or drain the machine indoors or inside an enclosed trailer.
- Do Not fill the fuel tank completely full. Add gasoline to the fuel tank until the level is 1/4 to 1/2 inch (6–13 mm) below the bottom of the filler neck. This empty space in the tank allows gasoline to expand.
- Never smoke when handling gasoline, and stay away from an open flame or where gasoline fumes may be ignited by spark.
- Store gasoline in an approved container and keep it out of the reach of children.
- Add fuel before starting the engine. Never remove the cap of the fuel tank or add fuel when engine is running or when the engine is hot.
- If fuel is spilled, Do Not attempt to start the engine. Move away from the area of the spill and avoid creating any source of ignition until fuel vapors have dissipated.
- Do Not operate without entire exhaust system in place and in proper working condition.

⚠ DANGER

In certain conditions during fueling, static electricity can be released causing a spark which can ignite gasoline vapors. A fire or explosion from gasoline can burn you and others and cause property damage.

- Always place gasoline containers on the ground away from your vehicle before filling.
- Do Not fill gasoline containers inside a vehicle or on a truck or trailer bed because interior carpets or plastic truck bed liners may insulate the container and slow the loss of any static charge.
- When practical, remove gas-powered equipment from the truck or trailer and refuel the equipment with its wheels on the ground.
- If this is not possible, then refuel such equipment on a truck or trailer from a portable container, rather than from a gasoline dispenser nozzle.
- If a gasoline dispenser nozzle must be used, keep the nozzle in contact with the rim of the fuel tank or container opening at all times until fueling is complete.

⚠ WARNING

Gasoline is harmful or fatal if swallowed. Long-term exposure to vapors has caused cancer in laboratory animals. Failure to use caution may cause serious injury or illness.

- Avoid prolonged breathing of vapors.
- Keep face away from nozzle and gas tank/container opening.
- Keep away from eyes and skin.
- Never siphon by mouth.

- Check that the operator's presence controls, safety switches, and shields are attached and functioning properly. Do Not operate unless they are functioning properly.

Safety

Operation

⚠ WARNING

Operating engine parts, especially the muffler, become extremely hot. Severe burns can occur on contact and debris, such as leaves, grass, brush, etc. can catch fire.

- Allow engine parts, especially the muffler, to cool before touching.
- Remove accumulated debris from muffler and engine area.
- Install and maintain in working order a spark arrester before using equipment on forest-covered, grass-covered, or brush-covered unimproved land.

⚠ WARNING

Engine exhaust contains carbon monoxide, which is an odorless deadly poison that can kill you.

Do Not run engine indoors or in a small confined area where dangerous carbon monoxide fumes can collect.

- Operate only in daylight or good artificial light, keeping away from holes and hidden hazards.
- Be sure all drives are in neutral and parking brake is engaged before starting engine. Use seat belts.
- Never operate the mower with damaged guards, shields, or covers. Always have safety shields, guards, switches and other devices in place and in proper working condition.
- Never mow with the discharge deflector raised, removed or altered unless there is a grass collection system or mulch kit in place and working properly.
- Do Not change the engine governor setting or overspeed the engine.
- Stop engine, wait for all moving parts to stop, remove key and engage parking brake:
 - Before checking, cleaning or working on the mower.
 - After striking a foreign object or abnormal vibration occurs (inspect the mower for

damage and make repairs before restarting and operating the mower).

- Before clearing blockages.
- Whenever you leave the mower.
- Stop engine, wait for all moving parts to stop, and engage parking brake:
 - Before refueling.
 - Before dumping the grass catcher.

⚠ WARNING

Hands, feet, hair, clothing, or accessories can become entangled in rotating parts. Contact with the rotating parts can cause traumatic amputation or severe lacerations.

- Do Not operate the machine without guards, shields, and safety devices in place and working properly.
- Keep hands, feet, hair, jewelry, or clothing away from rotating parts.
- **NEVER** carry passengers. **DO NOT** operate the mower when people, especially children, or pets are in the area.
- Be alert, slow down and use caution when making turns. Look behind and to the side before changing directions.
- Stop the blades, slow down, and use caution when crossing surfaces other than grass and when transporting the mower to and from the area to be mowed.
- Be aware of the mower discharge path and direct discharge away from others.
- Do Not operate the mower under the influence of alcohol or drugs.
- Use extreme care when loading or unloading the machine into a trailer or truck.
- Use care when approaching blind corners, shrubs, trees, or other objects that may obscure vision.

Slope Operation

Use **Extreme** caution when mowing and/or turning on slopes as loss of traction and/or tip-over could occur. The operator is responsible for safe operation on slopes.

⚠ DANGER

Operating on wet grass or steep slopes can cause sliding and loss of control. Wheels dropping over edges, ditches, steep banks, or water can cause rollovers, which may result in serious injury, death or drowning.

- Do Not mow slopes when grass is wet.
- Do Not mow near drop-offs or near water.
- Do Not mow slopes greater than 15 degrees.
- Reduce speed and use extreme caution on slopes.
- Avoid sudden turns or rapid speed changes.

- See inside the back cover to determine the approximate slope angle of the area to be mowed.
- Use a walk behind mower and/or a hand trimmer near drop-offs, ditches, steep banks or water. (Figure 3).

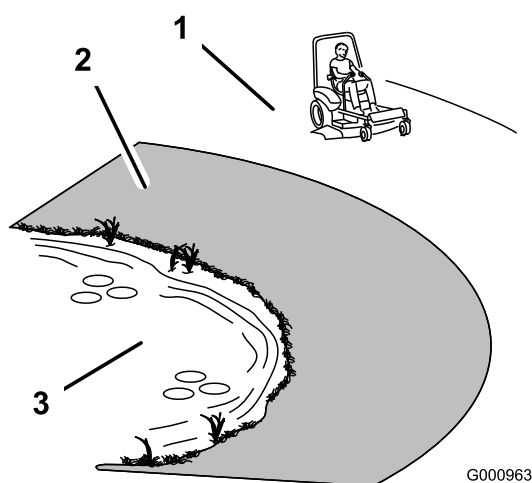

Figure 3

1. Safe Zone-Use the mower here on slopes less than 15 degrees
2. Danger Zone-Use a walk behind mower and/or hand trimmer near drop-offs and water.
3. Water

- Watch for ditches, holes, rocks, dips and rises that change the operating angle, as rough terrain could overturn the machine.
- Avoid sudden starts when mowing uphill because the mower may tip backwards.
- Be aware that loss of traction may occur going downhill. Weight transfer to the front wheels may cause drive wheels to slip and cause loss of braking and steering.
- Always avoid sudden starting or stopping on a slope. If tires lose traction, disengage the blades and proceed slowly off the slope.
- Follow the manufacturer's recommendations for wheel weights or counter weights to improve stability.
- Use extreme care with grass catchers or attachments. These can change the stability of the machine and cause loss of control.

Using the Rollover Protection System (ROPS)

A Rollover Protection System (roll bar) is installed on the unit.

⚠ WARNING

There is no rollover protection when the roll bar is down. Wheels dropping over edges, ditches, steep banks, or water can cause rollovers, which may result in serious injury, death or drowning.

- Keep the roll bar in the raised and locked position and use seat belt.
- Lower the roll bar only when absolutely necessary.
- Do Not wear seat belt when the roll bar is down.
- Drive slowly and carefully.
- Raise the roll bar as soon as clearance permits.

- Remove or mark obstacles such as rocks, tree limbs, etc. from the mowing area. Tall grass can hide obstacles.

- Check carefully for overhead clearances (i.e. branches, doorways, and electrical wires) before driving under any objects and do not contact them.

Maintenance and Storage

- Disengage drives, lower implement, set parking brake, stop engine and remove key or disconnect spark plug wire. Wait for all movement to stop before adjusting, cleaning or repairing.
- Keep engine, engine area, and pump drive belt compartment free from accumulation of grass, leaves, excessive grease or oil, and other debris which can accumulate in these areas. These materials can become combustible and may result in a fire.
- Let engine cool before storing and do not store near flame or any enclosed area where open pilot lights or heat appliances are present.
- Shut off fuel while storing or transporting. Do Not store fuel near flames or drain indoors.
- Park machine on level ground. Never allow untrained personnel to service machine.
- Use jack stands to support components when required.
- Carefully release pressure from components with stored energy.
- Disconnect battery or remove spark plug wire before making any repairs. Disconnect the negative terminal first and the positive last. Reconnect positive first and negative last.
- Use care when checking blades. Wrap the blade(s) or wear gloves, and use caution when servicing them. Only replace blades. Never straighten or weld them.
- Keep hands and feet away from moving parts. If possible, do not make adjustments with the engine running.
- Charge batteries in an open well ventilated area, away from spark and flames. Unplug charger before connecting or disconnecting from battery. Wear protective clothing and use insulated tools.
- Keep all guards, shields and all safety devices in place and in safe working condition.
- Check all bolts frequently to maintain proper tightness.
- Frequently check for worn or deteriorating components that could create a hazard.
- All replacement parts must be the same as or equivalent to the parts supplied as original equipment.

⚠ WARNING

Hydraulic fluid escaping under pressure can penetrate skin and cause injury. Fluid accidentally injected into the skin must be surgically removed within a few hours by a doctor familiar with this form of injury or gangrene may result.

- **Make sure all hydraulic fluid hoses and lines are in good condition and all hydraulic connections and fittings are tight before applying pressure to hydraulic system.**
- **Keep body and hands away from pinhole leaks or nozzles that eject high pressure hydraulic fluid.**
- **Use cardboard or paper, not your hands, to find hydraulic leaks.**
- **Safely relieve all pressure in the hydraulic system by placing the motion control levers in neutral and shutting off the engine before performing any work on the hydraulic system.**

Safety and Instructional Decals

- Keep all safety signs legible. Remove all grease, dirt and debris from safety signs and instructional labels.
- Replace all worn, damaged, or missing safety signs.
- When replacement components are installed, be sure that current safety signs are affixed to the replaced components.
- If an attachment or accessory has been installed, make sure current safety signs are visible.
- New safety signs may be obtained from your authorized Exmark equipment dealer or distributor or from Exmark Mfg. Co. Inc.
- Safety signs may be affixed by peeling off the backing to expose the adhesive surface. Apply only to a clean, dry surface. Smooth to remove any air bubbles.
- Familiarize yourself with the following safety signs and instruction labels. They are critical to the safe operation of your Exmark commercial mower.



1-303508



1-523552



1-403005

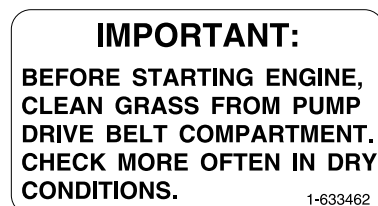

1-633462



1-513742



1-513748

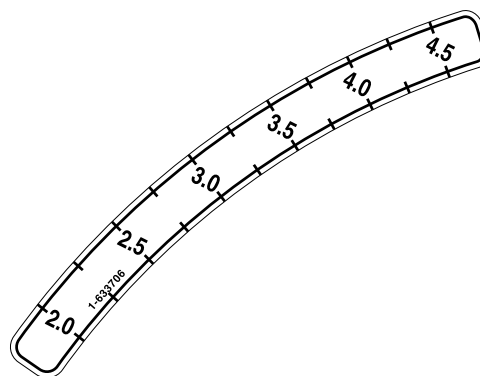

1-633706

**ANTI-SCALP ROLLER
ADJUSTMENT**

FOR NORMAL OPERATING CONDITIONS, PLACE ROLLERS IN POSITIONS SHOWN FOR 3/4" (19 mm) GROUND CLEARANCE.

CUTTING HEIGHT
INCHES(mm)

2.0 (51)
2.5 (64)
3.0 (76)
3.5 (90)

FOR MAXIMUM FLOTATION, ROLLERS MAY BE POSITIONED LOWER, BUT MUST MAINTAIN A MINIMUM OF 1/4" (6,4 mm) GROUND CLEARANCE. NEVER POSITION THE ROLLERS TO SUPPORT THE MOWER DECK.

1-633922

1-633922



103-1798

BELT ROUTING

BLADE BELT:
1-643052 - 72"
1-633127 - 60"
1-633366 - 52"

1-643222

1-643222

Engine RPM
3750 ± 50 (no load)

103-3270

103-3270

PUMP BELT ROUTING

1-643339

1-643339

103-4474

103-4474

⚠ DANGER

COVER IS MISSING. DO NOT OPERATE THIS UNIT WHEN COVER IS NOT IN PLACE.

98-5954

98-5954



103-4930



103-5881

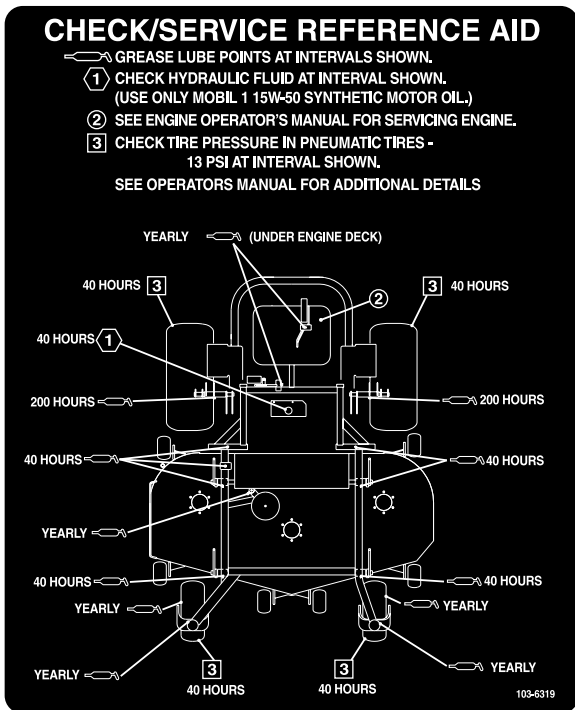

103-6319



107-2102

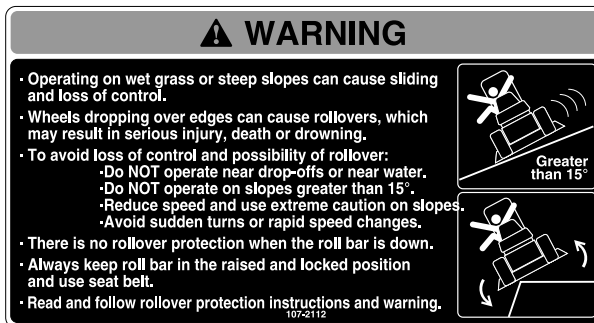

107-2112

Safety

RELEASE

PARK BRAKE

ENGAGE

WARNING

To avoid serious injury or death:

- Read and understand the operator's manual before using this machine.
- Do NOT operate unless trained to safely use this machine.
- Do NOT operate under the influence of alcohol or drugs.
- Do NOT operate without shields, guards, and safety devices in place and working.
- Check the function of the operator presence controls (OPC) safety system daily. Do NOT defeat the OPC system.
 - Stop engine and remove key before adjusting, servicing or cleaning machine and attachments.
 - Hearing protection is recommended.

109-1214

109-1214

Lubricate Blade Bolt threads with copper based antiseize or grease and torque to 55-60 ft-lbs (75-81 N-m)

109-3148

109-3148

Torque Wheel Lug Nuts to 90-95 ft-lbs (122-129 N-m).	Check after first 100 hrs then every 500 hrs thereafter.
Torque Wheel Hub Slotted Nut to 125 ft-lbs (169 N-m) min. See Operator's Manual for more details.	

109-7949

109-7949

DANGER

To avoid serious injury or death:

- Avoid blades unless engine and blades are stopped.

WARNING

To avoid serious injury or death:

- Pick up objects that could be thrown by the blades.
- Do NOT mow when people and pets are in the area.
- Do NOT carry passengers.
- Look behind and to the side before changing directions.
- Before leaving the operator's position:
 - Disengage PTO.
 - Move drive levers out to neutral lock position.
 - Engage park brake.
 - Stop engine.

CUTTING HEIGHT

109-1215

109-1215

MOTION CONTROL

N

R

WARNING Battery contains sulfuric acid. Avoid contact and always shield eyes, face, skin and clothing from battery. Cigarettes, flames or sparks could cause battery to explode. Do not charge or use booster cables or adjust post connections without proper training. In event of an accident flush with water immediately. Keep out of reach of children.

103-9255

DRIVE WHEEL RELEASE

 One turn counter-clockwise to release
 Do not over-tighten

MOTION CONTROL

N

R

103-9255

Specifications

Model Numbers

Serial Nos: 720,000 and Higher

LZ27KC604

Systems

Engine

- Engine Specifications: See your Engine Owner's Manual
- RPM: Full Speed: 3750 ±50 RPM (No Load)
Idle: 1500 RPM

Fuel System

- Capacity: 13.5 gal. (51.0 L)
- Type of Fuel: Regular unleaded gasoline, 87 octane or higher.
- Fuel Filter: In-line 15 Micron Kohler P/N 2405010.
- Fuel Shut-Off Valve: 1/4 turn increments ("ON", "OFF").
- Fuel gauge in left hand fuel tank.

Electrical System

- Charging System: Flywheel Alternator
- Charging Capacity: 15 amps
- Battery Type: BCI Group U1
- Battery Voltage: 12 Volt
- Polarity: Negative Ground
- Fuses: Two 20 amp blade type

Safety Interlock System

- PTO must be disengaged, brake engaged, and motion control levers out (neutral lock) to start engine. (It is not necessary for the operator to be in the seat to start the engine.)
- Operator must be in seat when PTO is engaged, brake is disengaged, or motion control levers are moved in or engine will stop.
- Engine will stop if either the left, the right, or both levers are moved from neutral lock position while brake is engaged.

Operator Controls

- Steering and Motion Control:

Note: Motion control levers are adjustable to two heights.

- Separate levers, on each side of the console, control speed and direction of travel of the respective drive wheels.
- Steering is controlled by varying the position of the levers relative to each other.
- Moving motion control levers outward (in slots) locks the drive system in neutral.
- PTO Engagement Switch: Engages electric clutch (to drive belt) which engages mower blades.
- Parking Brake Lever: Engages parking brake.
- Deck Height Adjustment Lever: Sets cutting height to desired position.
- Deck Lift Assist Lever: Foot pedal that assists in raising the deck.

Seat

- Type: Standard seat with high back, foam padded (internal suspension) and armrests.

Optional seat accessories:

- Custom ride suspension system to enhance Standard Seat.
- Deluxe suspension seat with high back, low profile foam-in-place cushion (dampened, adjustable spring suspension) and armrests.
- Mounting: Hinged to tilt up for access to hydraulic pumps, battery and other components. Held in tilted position with prop rod. Adjustable fore and aft seat track.
- Armrests:
 - Standard seat: foam padded flip-up armrests.

Specifications

- Optional suspension seat: molded adjustable flip-up armrests.
- Seat Safety Switch: Incorporated into the Safety Interlock System. Time delay seat switch eliminates rough ground cut-outs.

Hydrostatic Ground Drive System

- Hydrostatic Pumps: Two Hydro Gear variable displacement piston pumps.
- Wheel Motors: Two Parker with 1 1/4 inch tapered shafts.
- Hydraulic Oil Type: Use Mobil 1 15W-50 Synthetic motor oil.
- Hydraulic Oil Capacity: 2.1 qt. (2.0 L)
- Hydraulic Filter: Replaceable cartridge type.
 - Summer use above 32°F (0°C)
P/N 109-4180: 25 microns, 10 psi bypass
 - Winter use below 32°F (0°C)
P/N 1-523541: 40 microns, 18 psi bypass
- Speeds:
 - 0–9.8 mph (15.8 km/hr) forward.
 - 0–6.3 mph (10.1 km/hr) reverse.
- Drive wheel release valves allow machine to be moved when engine is not running.

Tires & Wheels

	Drive	Front Caster
	Pneumatic (Air-Filled)	Semi-Pneumatic
Quantity	2	2
Tread Size	“Multi- Trac C/S”	Smooth
Size	24 x 12.00-12	13 x 6.50-6
Ply Rating	4	
Pressure	13 psi (90 kPa)	

Cutting Deck

- Cutting Width: 60 inch (152.4 cm)
- Discharge: Side
- Blade Size: (3 ea.) 20.50 inches (52.1 cm)
- Blade Spindles: Solid steel spindles with 1 inch (25.4 mm) I.D. bearings.

- Deck Drive:
 - Electric clutch mounted on horizontal engine shaft. “B” Section belt (with self-tensioning idler) from electric clutch to transfer shaft mounted on deck.
 - Blades are driven by one “B” Section belt (w/self-tensioning idler) from transfer shaft on deck to blade spindles.

Deck:

Full floating deck is attached to out-front support frame. Six anti-scalp rollers provide maximum turf protection. Deck design allows for bagging, mulching or side discharge.

- Deck Depth: 5.5 inches (14.0 cm)

Cutting Height Adjustment:

An extra-long cushioned lever is used to adjust the cutting height from 1 1/2 inch (3.8 cm) to 5 inches (12.7 cm) in 1/4 inch (6.4 mm) increments. The cutting height adjustment handle has a transport position and all adjustments can be made while the operator remains seated. Units also have a foot operated deck lift assist lever to aid in raising the deck.

- Mulching Kit: Optional.

Dimensions

Overall Width:

Without Deck	53.5 inches (135.9 cm)
Deflector Up	61.4 inches (156.0 cm)
Deflector Down	72.2 inches (183.4 cm)

Overall Length:

Roll Bar - Up	81.9 inches (208.0 cm)
Roll Bar - Down	92.6 inches (235.2 cm)

Overall Height:

Roll Bar - Up	Roll Bar - Down
71.9 in. (182.6 cm)	53.8 inches (136.7 cm)

Tread Width: (Center to Center of Tires, Widthwise)

Drive Wheels	41.9 inches (106.4 cm)
Caster Wheels	37.3 inches (94.7 cm)

Wheel Base: (Center of Caster Tire to Center of Drive Tire)

53.7 inches (136.4 cm)

Curb Weight:

1290 lb (585 kg)

Torque Requirements

Bolt Location	Torque
Cutter Housing Spindle Nut	140-145 ft-lb (190-197 N-m)
Blade Mounting Bolt (lubricate with anti-seize)	55-60 ft-lb (75-81 N-m)
Engine Deck/Front Frame Mount Bolts	30-35 ft-lb (41-47 N-m)
Anti-Scalp Roller Nyloc Nut See Figure 10	30-35 ft-lb (41-47 N-m)
Anti-Scalp Roller Whizlock Nut See Figure 10	30-35 ft-lb (41-47 N-m)
Engine Mounting Bolts	30-35 ft-lb (41-47 N-m)
Wheel Lug Nuts	90-95 ft-lb (122-129 N-m)
Wheel Motor Mounting Bolts	72-77 ft-lb (98-104 N-m)
Wheel Hub Slotted Nut	minimum 125 ft-lb (169 N-m)
Rollover Protection System (Roll Bar) Mounting Bolts	30-35 ft-lb (41-47 N-m)
Deck Drive Jackshaft Nut	75-80 ft-lb (102-108 N-m)
Clutch Retaining Bolt (secured with threadlocker)	55-60 ft-lb (75-81 N-m)

Product Overview

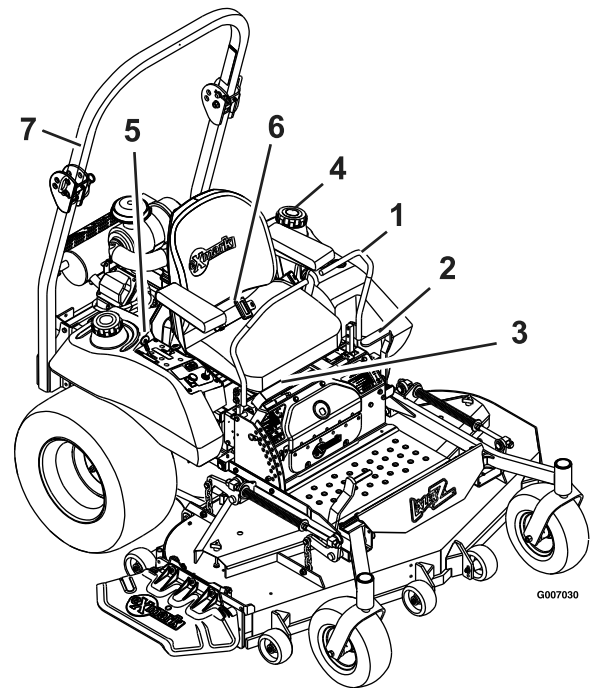

Figure 4

- 1. Motion Control Lever
- 2. Parking Brake Lever
- 3. Height-of-Cut Lever
- 4. Fuel Cap (Both Sides)
- 5. Controls
- 6. Seat Belt
- 7. Roll Bar

Operation

Note: Determine the left and right sides of the machine from the normal operating position.

Controls

Motion Control Levers

The motion control levers located on each side of the console control the forward and reverse motion of the machine. The levers control the flow of hydraulic oil from the hydrostatic pump to the drive wheel motor for each side.

Moving the levers forward or backward turns the wheel on the same side forward or in reverse. Wheel speed is proportional to the amount the lever is moved.

Moving the levers outward from the center position into the T-slot locks them in the neutral position (Figure 6).

Choke Control

Located on right fuel tank.

The choke is used to aid in starting a cold engine. Moving the choke lever forward will put the choke in the “ON” position and moving the choke lever to the rear, to the detent, will put the choke in the “OFF” position. Do Not run a warm engine with choke in the “ON” position.

Throttle Control

Located on right fuel tank.

The throttle is used to control engine speed. Moving the throttle lever forward will increase engine speed and moving the throttle lever to the rear will decrease engine speed. Moving the throttle forward into the detent is full throttle.

Brake Lever

Located on left side of unit, just to the front of the console.

The brake lever engages a parking brake on the drive wheels.

Pull the lever up and rearward to engage the brake.

Push the lever forward and down to disengage the brake.

The unit must be tied down and brake engaged when transporting.

Ignition Switch

Located on right fuel tank.

The ignition switch is used to start and stop the engine. The switch has three positions “OFF”, “ON” and “START”. Insert key into switch and rotate clockwise to the “ON” position. Rotate clockwise to the next position to engage the starter (key must be held against spring pressure in this position).

Note: Brake must be engaged, motion control levers out (neutral lock position) and PTO switch “OFF” to start engine. (It is not necessary for the operator to be in the seat to start the engine.)

Hour Meter

Located on the right fuel tank.

The hour meter is connected to a pressure switch installed in the engine block and it records the number of hours that the engine has run. If the ignition switch is left on without engine running, hour meter will not run.

Note: This switch is not a low oil sensor and will not alert the operator if the engine oil is low.

Fuel Shut-Off Valve

The fuel shut-off valve is used to shut off the fuel when the machine will not be used for a few days, during transport to and from the jobsite, and when parked inside a building.

The valve is located in the fuel line behind and to the right of the seat.

Rotate the valve 1/4 turn clockwise to shut off fuel. Rotate the valve 1/4 turn counterclockwise to turn on fuel.

Fuel Gauge

Located on the left fuel tank.

The fuel gauge monitors the amount of fuel in both tanks. Fuel is used evenly from both tanks.

Drive Wheel Release Valves

Located on the top right front corner of hydrostatic pumps.

Drive wheel release valves are used to release the hydrostatic drive system to allow the machine to be pushed without the engine running. Unhook seat latch and tilt seat up to gain access to pumps.

With a 7/16 inch wrench, turn both valves one turn counterclockwise to release drive system. Turn clockwise to reset system. **Do Not overtighten. Do Not tow machine.**

PTO Engagement Switch

Located on right fuel tank.

Switch must be pulled out to the “ROTATE” position to engage the blades. Switch is pushed in to the “STOP” position to stop the blades.

Pre-Start

Fill fuel tanks. For best results use only clean, fresh regular grade unleaded gasoline with an octane rating of 87 or higher. Regular grade leaded gasoline may also be used; however, combustion chamber and cylinder head will require more frequent service. See Engine Owner’s Manual.

Do Not add oil to gasoline.

Do Not overfill fuel tank. Never fill the fuel tank so that the fuel level rises above a level that is 1/2 inch (13 mm) below the bottom of the filler neck to allow for fuel expansion and prevent fuel spillage.

Make sure you understand the controls, their locations, their functions, and their safety requirements.

Refer to the Maintenance section and perform all the necessary inspection and maintenance steps.

Operating Instructions

Raise the Rollover Protection System (ROPS)

Important: Lower the roll bar only when absolutely necessary.

1. Remove the hairpin cotter pins and remove the two roll bar pins (Figure 5).
2. Raise the roll bar to the upright position and install the two pins and secure them with the hairpin cotter pins (Figure 5).

Important: Always use the seat belt with the roll bar in the raised position. Ensure that the rear part of the seat is secured with the seat latch.

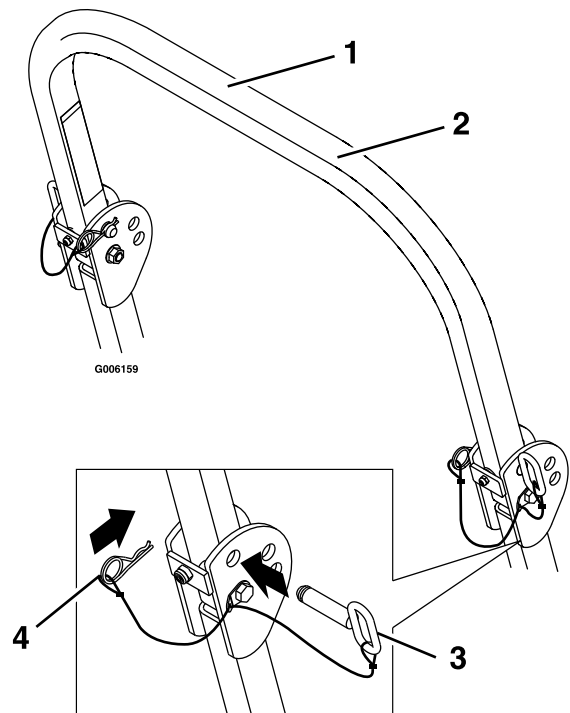

Figure 5

- | | |
|--------------------|-----------------------|
| 1. Roll bar | 3. Pin |
| 2. Raised position | 4. Hairpin cotter pin |

Open the Fuel Shut-Off Valve

The fuel shut off valve is located in the fuel line behind and to the right or left of the seat. Rotate the valve 1/4 turn counterclockwise to turn on fuel.

Starting the Engine

1. Move the motion control levers out to the neutral lock position.
2. Pull up and back on the parking brake lever to engage the parking brake.
3. Push in on the PTO switch to the “STOP” position.

Note: It is not necessary for the operator to be in the seat to start the engine.

Operation

4. Place the throttle midway between the “SLOW” and “FAST” positions.
5. On a cold engine, push the choke lever forward into the “ON” position.

On a warm engine, leave the choke in the “OFF” position.

6. Turn ignition switch to the “START” position. Release the switch as soon as the engine starts.

Important: Do Not crank the engine continuously for more than ten seconds at a time. If the engine does not start, allow a 60 second cool-down period between starting attempts. Failure to follow these guidelines can burn out the starter motor.

7. If the choke is in the “ON” position, gradually return choke to the “OFF” position as the engine warms up.

Engaging the PTO

DANGER

The rotating blades under the mower deck are dangerous. Blade contact can cause serious injury or kill you.

Do Not put hands or feet under the mower or mower deck when the blades are engaged.

DANGER

An uncovered discharge opening will allow objects to be thrown in an operator’s or bystander’s direction. Also, contact with the blade could occur. Thrown objects or blade contact can cause serious injury or death.

Never operate the mower with the discharge deflector raised, removed, or altered unless there is a grass collection system or mulch kit in place and working properly.

The PTO push-pull switch engages the cutting blades. Be sure that all persons are clear of the mower deck and discharge area before engaging PTO.

Important: Operator must be in seat before the PTO can be engaged.

1. Set the throttle to the “MIDWAY” position.

2. Pull the PTO switch outward to the “ROTATE” position.
3. Place the throttle in the “FAST” position to begin mowing.

Disengaging the PTO

1. Set the throttle to the “MIDWAY” position.
2. Push the PTO switch in to the “STOP” position to disengage the blades.

Stopping the Engine

1. Bring the unit to a full stop.
2. Disengage the PTO.
3. Move the motion control levers out to the neutral lock position.
4. Engage the parking brake.
5. Place the throttle midway between the “SLOW” and “FAST” positions.
6. Allow the engine to run for a minimum of 15 seconds, then turn the ignition switch to the “OFF” position to stop the engine.
7. Remove the key to prevent children or other unauthorized persons from starting engine.
8. Close the fuel shut-off valve when the machine will not be in use for a few days, when transporting, or when the unit is parked inside a building.

Driving the Machine

CAUTION

Machine can spin very rapidly by positioning one lever too much ahead of the other. Operator may lose control of the machine, which may cause damage to the machine or injury.

- Use caution when making turns.
- Slow the machine down before making sharp turns.

Important: To begin movement (forward or backward) the operator must be in the seat, the brake lever must be disengaged (pushed down) before the motion control levers can be moved in or the engine will stop.

When levers are centered in the T-slot the drive system is in the neutral position. With levers moved out in the T-slot the drive system is in the neutral lock position (Figure 6).

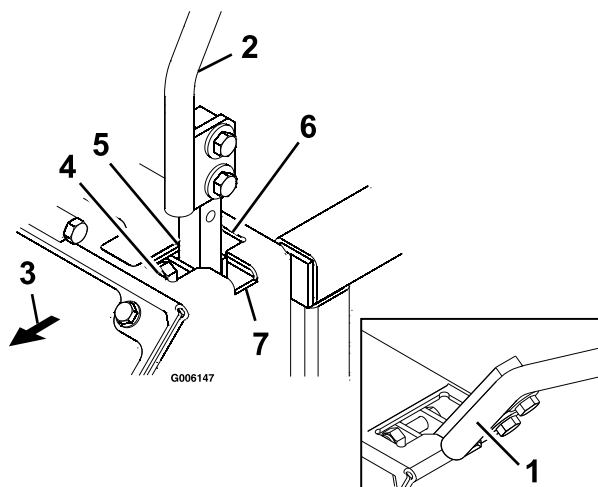

Figure 6

- | | |
|-------------------------------|-----------------|
| 1. Handles Out (Neutral Lock) | 5. Neutral |
| 2. Handles In (Neutral) | 6. Reverse |
| 3. Front of Unit | 7. Neutral Lock |
| 4. Forward | |

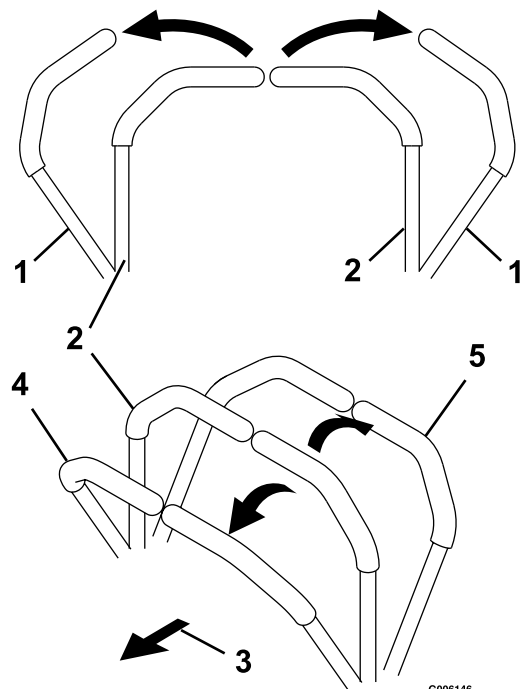

Figure 7

- | | |
|-------------------------------|------------|
| 1. Handles Out (Neutral Lock) | 4. Forward |
| 2. Handles In (Neutral) | 5. Reverse |
| 3. Front of Unit | |

Driving Forward

1. Release the parking brake.
2. Move the motion control levers inward to the center to the neutral unlocked position.
3. To move forward in a straight line apply equal forward pressure to both levers.

To turn left or right, pull the motion control lever back toward neutral in the direction desired.

The machine will move faster the farther the motion control levers are moved away from neutral.

4. To stop, pull the motion control levers back to the neutral position.

Driving in Reverse

1. Move the motion control levers inward to the center to the neutral unlocked position.
2. To move rearward in a straight line applying equal pressure pull both motion control levers rearward. To turn left or right, release pressure on the motion control lever toward the direction desired.
3. To stop, push the motion control levers to the neutral position.

Adjusting the Cutting Height

The cutting height of the mower deck is adjusted from 1 1/2 to 5 inches (3.8 cm to 12.7 cm) in 1/4 inch (6.4 mm) increments.

1. Stop the machine and move the motion control levers outward to the neutral locked position.
2. Disengage the PTO.
3. Raise the deck height lever to the transport position (also the 5 inch (12.7 cm) cutting height position)(Figure 8).

The deck can be raised by pulling the deck lever up and/or by pushing down on the foot operated

Operation

deck lift assist lever located at the front right corner of the floor pan.

Note: When changing the cutting height positions, always come to a complete stop and disengage the PTO.

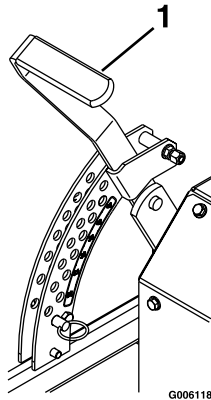

Figure 8

1. Lever in transport and 5 inch (12.7 cm) cutting height position

4. Insert the height adjustment pin into the hole corresponding to the desired cutting height and install the hairpin cotter pin.

See the decal on the side of the deck lift plate for cut heights.

5. Move the deck height lever out of the transport position (or 5 inch (12.7 cm) cutting height) and down onto the height adjustment pin to mow at selected height.

Note: The foot operated deck lift assist lever can be used to momentarily lift the deck to clear objects. Be sure that PTO is disengaged.

Adjusting the Anti-Scalp Rollers

It is recommended to change the anti-scalp roller position, when the height of cut has changed.

1. Stop the machine and move the motion control levers outward to the neutral locked position.
2. Disengage the PTO.
3. Engage the park brake.
4. Stop the engine, remove the key and wait for all moving parts to stop.
5. After adjusting the height of cut, adjust the anti-scalp rollers by removing the nyloc nut, bushing, spring disc washer and whizlock nut.

6. Place the rollers in one of the positions shown (Figure 9). Rollers will maintain 3/4 inch (19 mm) clearance to the ground to minimize gouging and roller wear or damage.

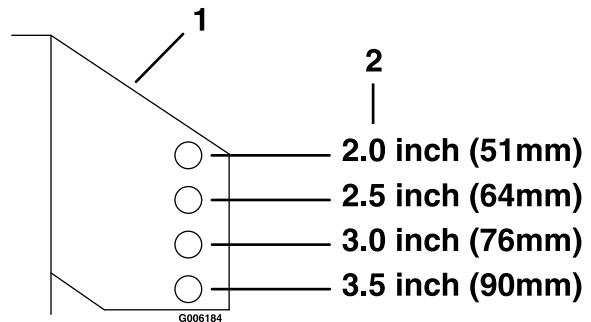

Figure 9

For cutting heights above 3.5 inches (90 mm) use the bottom hole. The rollers will still be effective against scalping.

1. Anti-scalp roller mounting bracket
2. Cutting height

For Maximum Deck Flotation, place the rollers one hole position lower. Rollers should maintain 1/4 inch (6.4 mm) clearance to the ground. **Do Not** adjust the rollers to support the deck.

7. Be sure the whizlock nuts are installed with the spring disc washer between the head of the nut and the mounting bracket.
Note: The foot operated deck lift assist lever can be used to momentarily lift the deck to clear objects. Be sure that PTO is disengaged.
8. Torque the 3/8–16 whizlock nut to 30-35 ft-lb (41-47 N-m) (Figure 10).
9. Torque the 3/8 nyloc nut to 30–35 ft-lb (41-47 N-m).

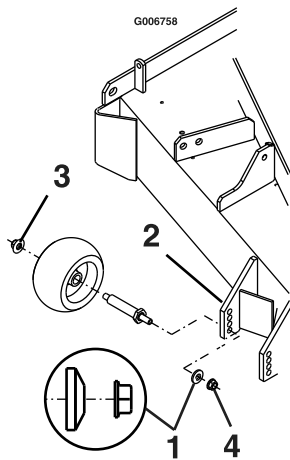

Figure 10

- | | |
|--|--|
| 1. Spring disc washer (cone towards nut) | 3. 3/8 nyloc-torque to 30-35 ft-lb (41-47 N-m) |
| 2. Front right anti-scalp bracket shown | 4. 3/8-16 whizlock nut torque to 30-35 ft-lb (41-47 N-m) |

Transporting

Transporting a Unit

Use a heavy-duty trailer or truck to transport the machine. Lock brake and block wheels. Securely fasten the machine to the trailer or truck with straps, chains, cable, or ropes. Be sure that the trailer or truck has all necessary lighting and marking as required by law. Secure a trailer with a safety chain.

⚠ CAUTION

This unit does not have proper turn signals, lights, reflective markings, or a slow moving vehicle emblem. Driving on a street or roadway without such equipment is dangerous and can lead to accidents causing personal injury. Driving on a street or roadway without such equipment may also be a violation of State laws and the operator may be subject to traffic tickets and/or fines.

Do Not drive a unit on a public street or roadway.

⚠ WARNING

Loading a unit on a trailer or truck increases the possibility of backward tip-over. Backward tip-over could cause serious injury or death.

- Use extreme caution when operating a unit on a ramp.
- Use only a single, full width ramp; Do Not use individual ramps for each side of the unit.
- If individual ramps must be used, use enough ramps to create an unbroken ramp surface wider than the unit.
- Do Not exceed a 15° angle between ramp and ground or between ramp and trailer or truck.
- Avoid sudden acceleration while driving unit up a ramp to avoid tipping backward.
- Avoid sudden deceleration while backing unit down a ramp to avoid tipping backward.

Loading a Unit

Use extreme caution when loading units on trailers or trucks. One full width ramp that is wide enough to extend beyond the rear tires is recommended instead of individual ramps for each side of the unit. The lower rear section of the tractor frame extends back between the rear wheels and serves as a stop for tipping backward. Having a full width ramp provides a surface for the frame members to contact if the unit starts to tip backward. If it is not possible to use one full width ramp, use enough individual ramps to simulate a full width continuous ramp.

Ramp should be long enough so that the angles between the ramp and the ground and the ramp and the trailer or truck do not exceed 15°. A steeper angle may cause mower deck components to get caught as the unit moves from ramp to trailer or truck. Steeper angles may also cause the unit to tip backward. If loading on or near a slope, position the trailer or truck so it is on the down side of the slope and the ramp extends up the slope. This will minimize the ramp angle. The trailer or truck should be as level as possible.

Operation

Important: Do Not attempt to turn the unit while on the ramp, you may lose control and drive off the side.

Avoid sudden acceleration when driving up a ramp and sudden deceleration when backing down a ramp. Both maneuvers can cause the unit to tip backward.

Maintenance

Note: Determine the left and right sides of the machine from the normal operating position.

⚠ WARNING

While maintenance or adjustments are being made, someone could start the engine. Accidental starting of the engine could seriously injure you or other bystanders.

Remove the key from the ignition switch, engage parking brake, and pull the wire(s) off the spark plug(s) before you do any maintenance. Also push the wire(s) aside so it does not accidentally contact the spark plug(s).

⚠ WARNING

The engine can become very hot. Touching a hot engine can cause severe burns.

Allow the engine to cool completely before service or making repairs around the engine area.

Recommended Maintenance Schedule(s)

Maintenance Service Interval	Maintenance Procedure
After the first 5 hours	<ul style="list-style-type: none"> • Change the engine oil.
After the first 100 hours	<ul style="list-style-type: none"> • Check the wheel hub slotted nut torque specifications. • Check the wheel lug nuts.
After the first 250 hours	<ul style="list-style-type: none"> • Change the hydraulic filter.
Before each use or daily	<ul style="list-style-type: none"> • Check the engine oil level. • Check the mower blades. • Check the safety interlock system. • Check the rollover protections systems (roll bar) pins. • Check the seat belt. • Check for loose hardware. • Clean the engine cooling system. • Clean the grass build-up from under the deck.
Every 40 hours	<ul style="list-style-type: none"> • Check the hydraulic oil level. • Check the tire pressures. • Check the condition of the belts. • Grease the height adjustment shaft bearings. • Grease the rear deck struts.
Every 50 hours	<ul style="list-style-type: none"> • Service the air cleaner. (May need more often under severe conditions. See the Engine Owner's Manual for additional information.)
Every 80 hours	<ul style="list-style-type: none"> • Remove the engine shrouds and clean the cooling fins.
Every 100 hours	<ul style="list-style-type: none"> • Change the engine oil. (May need more often under severe conditions.)
Every 160 hours	<ul style="list-style-type: none"> • Lubricate the brake handle pivot. • Lubricate the brake rod bushings. • Lubricate the motion control bronze bushings. • Lubricate the seat switch actuator. • Check the spark plugs.

Maintenance

Maintenance Service Interval	Maintenance Procedure
Every 200 hours	<ul style="list-style-type: none"> Grease the brake brackets.
Every 500 hours	<ul style="list-style-type: none"> Check the wheel hub slotted nut torque specifications. Check the wheel lug nuts.
Monthly	<ul style="list-style-type: none"> Check the battery charge.
Yearly	<ul style="list-style-type: none"> Grease front caster pivots. Grease the deck drive belt idler arm. Grease the mule drive belt idler arm. Grease the pump drive belt idler arm. Lubricate the caster wheel hubs. Change the hydraulic filter.

Periodic Maintenance

Check Engine Oil Level

Service Interval: Before each use or daily

1. Stop engine and wait for all moving parts to stop. Make sure unit is on a level surface.
2. Check with engine cold.
3. Clean area around dipstick. Remove dipstick and wipe oil off. Reinsert the dipstick and push it all the way down into the tube. Remove the dipstick and read the oil level.
4. If the oil level is low, wipe off the area around the oil fill cap, remove cap and fill to the "FULL" mark on the dipstick. Use oil as specified in Engine Owner's Manual. **Do Not** overfill.

Important: Do Not operate the engine with the oil level below the "LOW" (or "ADD") mark on the dipstick, or over the "FULL" mark.

Check Battery Charge

Service Interval: Monthly

Allowing batteries to stand for an extended period of time without recharging them will result in reduced performance and service life. To preserve optimum battery performance and life, recharge batteries in storage when the open circuit voltage drops to 12.4 volts.

Note: To prevent damage due to freezing, battery should be fully charged before putting away for winter storage.

Check the voltage of the battery with a digital voltmeter. Locate the voltage reading of the battery in the table and charge the battery for the recommended time interval to bring the charge up to a full charge of 12.6 volts or greater.

Important: Make sure the negative battery cables are disconnected and the battery charger used for charging the battery has an output of 16 volts and 7 amps or less to avoid damaging the battery (see chart for recommended charger settings).

⚠ WARNING

CALIFORNIA Proposition 65 Warning

Battery posts, terminals, and related accessories contain lead and lead compounds, chemicals known to the State of California to cause cancer and reproductive harm. Wash hands after handling.

Voltage Reading	Percent Charge	Maximum Charger Settings	Charging Interval
12.6 or greater	100%	16 volts/7 amps	No Charging Required
12.4 – 12.6	75–100%	16 volts/7 amps	30 Minutes
12.2 – 12.4	50–75%	16 volts/7 amps	1 Hour
12.0–12.2	25–50%	14.4 volts/4 amps	2 Hours
11.7–12.0	0–25%	14.4 volts/4 amps	3 Hours
11.7 or less	0%	14.4 volts/2 amps	6 Hours or More

Check Mower Blades

Service Interval: Before each use or daily

1. Stop engine, wait for all moving parts to stop, and remove key. Engage parking brake.
2. Lift deck and secure in raised position as stated in the **Clean Grass Build-Up Under Deck** section.
3. Inspect blades and sharpen or replace as required.
4. Reinstall the blades (if they were removed) in the following order:
 - A. Install bushing through blade with bushing flange on bottom (grass) side of blade.

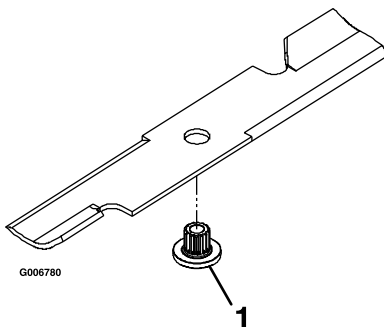

Figure 11

1. Install bushing in blade prior to installing bushing in spindle.

- B. Install bushing/blade assembly into spindle.

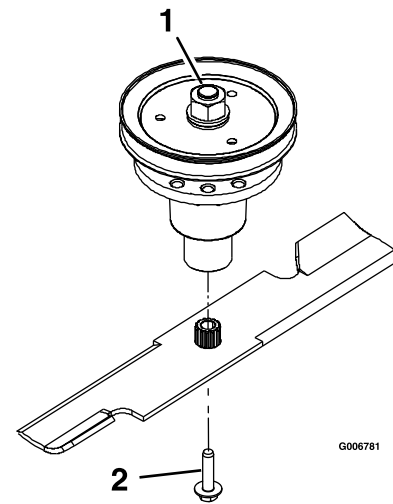

Figure 12

1. Use wrench here for blade installation. This nut has been torqued to 140–145 ft-lb (190–197 N-m)
2. Torque to 55-60 ft-lb (75-81 N-m) Apply lubricant to threads as needed to prevent seizing. Copper-based anti-seize preferable. Grease acceptable substitute.

- C. Apply lubricant to threads of blade bolt as needed to prevent seizing. Copper-based anti-seize preferable. Grease acceptable substitute. Install blade bolt finger tight. Place wrench on the top spindle nut then torque the blade bolts to 55-60 ft-lb (75-81 N-m).

⚠ WARNING

Incorrect installation of the blade or components used to retain the blade can be dangerous. Failure to use all original components and assembled as shown could allow a blade or blade component to be thrown out from under the deck resulting in serious personal injury or death.

Always install the original Exmark blades, blade bushings, and blade bolts as shown.

Check Safety Interlock System

Service Interval: Before each use or daily

Note: To prevent engine cut-outs on rough terrain the seat kill switch has a 1/2 second delay.

Maintenance

1. Check starting circuit. Starter **should** crank with, parking brake **engaged**, PTO **disengaged** and motion control levers moved out in the **neutral lock** position. The operator does not need to be in the seat to start the engine.

Try to start with **operator in seat**, parking brake disengaged, PTO disengaged and motion control levers in the **neutral lock** position - starter **must not crank**.

Try to start with **operator in seat**, parking brake engaged, PTO **engaged** and motion control levers in the **neutral lock** position - starter **must not crank**.

Try to start with **operator in seat**, parking brake **engaged**, PTO **disengaged**, and the **left motion control lever in**, starter **must not crank**, repeat again with the **right lever in**, then with **both levers in** - starter **must not crank**.

2. Check the kill circuits. Run engine at one-third throttle, **disengage** parking brake and **raise off** of seat (but do not get off of machine) engine **must initiate shutdown** after approximately 1/2 second has elapsed (seat has time delay kill switch to prevent cut-outs on rough terrain).

Run engine at one-third throttle, **engage PTO** and **raise off** of seat (but do not get off of machine) engine **must initiate shutdown** after 1/2 second has elapsed.

Run engine at one-third throttle, with brake disengaged, move levers in and raise off seat (but do not get off of machine) engine **must initiate shutdown** after 1/2 second has elapsed.

Again, run engine at one-third throttle, brake **engaged**, and move **left motion control lever in** - engine **must initiate shutdown**.

Repeat again moving the **right lever in**, then moving **both levers in** - engine **must initiate shutdown** whether operator is **on seat or not**.

Note: If machine does not pass any of these tests, do not operate. Contact your authorized **EXMARK SERVICE DEALER**.

Important: It is essential that operator safety mechanisms be connected and in proper operating condition prior to use for mowing.

Check Rollover Protections Systems (Roll Bar) Pins

Service Interval: Before each use or daily

Make sure latch pin and hair pin are fully installed and lanyard is in good condition.

Check Seat Belt

Service Interval: Before each use or daily

Visually inspect seat belt for wear, cuts, and proper operation of retractor and buckle. Replace before operating if damaged.

Check for Loose Hardware

Service Interval: Before each use or daily

1. Stop engine, wait for all moving parts to stop, and remove key. Engage parking brake.
2. Visually inspect machine for any loose hardware or any other possible problem. Tighten hardware or correct the problem before operating.

Service Air Cleaner

Service Interval: Every 50 hours—Service the air cleaner. (May need more often under severe conditions. See the Engine Owner's Manual for additional information.)

1. Stop engine, wait for all moving parts to stop, and remove key. Engage parking brake.
2. Unhook seat latch and tilt seat up to gain access to the air cleaner.
3. Loosen retaining clips and remove air cleaner compartment cover.
4. Remove paper element. Check the condition of the paper element. Replace if dirty, bent or damaged.
5. Check the condition of the inner element. Replace whenever it appears dirty, typically every other time the paper element is replaced. Clean the base around the inner element before removing, so dirt does not get into the engine.

6. **Do Not** wash or use pressurized air to clean paper element or inner element.
7. Reinstall elements. Position the cover so that the rubber dust ejector is pointing downward and secure with retaining clips.

Change Engine Oil

Service Interval: After the first 5 hours

**Every 100 hours/Yearly
(whichever comes first)
(May need more often
under severe conditions.)**

1. Stop engine, wait for all moving parts to stop, and remove key. Engage parking brake.
2. Drain oil while engine is warm from operation.
3. The oil drain hose is located on right hand side of engine. Place pan under machine to catch oil. Remove plug from end of drain hose. Allow oil to drain and replace oil drain plug. Torque plug to 20-24 ft-lb (27-33 N-m).
4. Replace the oil filter every other oil change. Clean around oil filter and unscrew filter to remove. Before reinstalling new filter, apply a thin coating of oil on the surface of the rubber seal. Turn filter clockwise until rubber seal contacts the filter adapter then tighten filter an additional 1/2 to 3/4 turn.
5. Clean around oil fill cap and remove cap. Fill to specified capacity and replace cap.
6. Use oil recommended in engine owner's manual. **Do Not** overfill. Start the engine and check for leaks.

Check Hydraulic Oil Level

Service Interval: Every 40 hours

1. Stop engine and wait for all moving parts to stop. Engage parking brake.
2. Clean area around hydraulic reservoir cap and remove cap. Oil level should be to the top of the baffle inside the tank. If not, add oil. Use only Mobil 1 15W-50 synthetic motor oil. Replace hydraulic reservoir cap and tighten until snug. Do Not overtighten.

Note: The baffle is labeled "HOT" and "COLD". The oil level varies with the temperature of the oil. The "HOT" level shows

the level of oil when it is at 225°F (107°C). The "COLD" level shows the level of the oil when it is at 75°F (24°C). Fill to the appropriate level depending upon the temperature of the oil. For example: If the oil is about 150°F (65°C), fill to halfway between the "HOT" and "COLD" levels. If the oil is at room temperature (about 75°F (24°C)), fill only to the "COLD" level.

Check Tire Pressures

Service Interval: Every 40 hours

1. Stop engine, wait for all moving parts to stop, and remove key. Engage parking brake.
2. Check tire pressure in drive tires.
3. Inflate drive tires to 13 psi (90 kPa).
4. Semi-pneumatic caster tires do not need to be inflated.

Note: Do Not add any type of tire liner or foam fill material to the tires. Excessive loads created by foam filled tires may cause failures to the hydro drive system, frame, and other components. Foam filling tires will void the warranty.

Check Condition Of Belts

Service Interval: Every 40 hours

1. Stop engine, wait for all moving parts to stop, and remove key. Engage parking brake.
2. Unhook seat latch and tilt seat up. Lift the rubber flap on front side of the engine to check pump drive belt.
3. Remove left and right belt shields on deck and lift up floor pan to inspect deck drive belt.
4. Check under machine to inspect the mule drive belt. See **Mule Drive Belt Tension Adjustment** section.

Lubricate Grease Fittings

Note: See chart for service intervals.

1. Stop engine, wait for all moving parts to stop, and remove key. Engage parking brake.
2. Lubricate fittings with one to two pumps of NGLI grade #2 multi-purpose gun grease.

Refer to the following chart for fitting locations and lubrication schedule.

Maintenance

Lubrication Chart			
Fitting Locations	Initial Pumps	Number of Places	Service Interval
1. Front Caster Wheel Hubs	*0	2	*Yearly
2. Front Caster Pivots	*0	2	*Yearly
3. Height Adjustment Shaft Bearings	1	5	40 Hours
4. Deck Drive Belt Idler Arm	1	1	Yearly
5. Brake Brackets	1	2	200 Hours
6. Mule Drive Belt Idler Arm	1	1	Yearly
7. Pump Drive Belt Idler Arm	1	1	Yearly
8. Deck Rear Struts	1	2	40 Hours

* See step 3 for special lubrication instructions on the front caster pivots and the **Lubricate Caster Wheel Hubs** section for special lubrication instructions on the front casters wheel hubs.

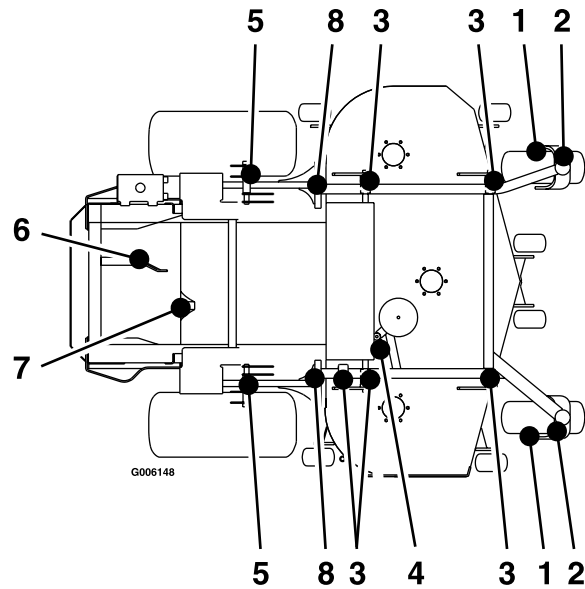

Number 6 (Mule Drive Belt Idler Arm) Located Under Engine Frame
 Number 7 (Pump Drive Belt Idler Arm) Located Under Engine Frame

- Lubricate front caster pivots once a year. Remove hex plug and cap. Thread grease zerk in hole and pump with grease until it oozes out around top bearing. Remove grease zerk and thread plug back in. Place cap back on.

Lubricate Caster Wheel Hubs

Service Interval: Yearly

- Stop engine, wait for all moving parts to stop, and remove key. Engage parking brake.

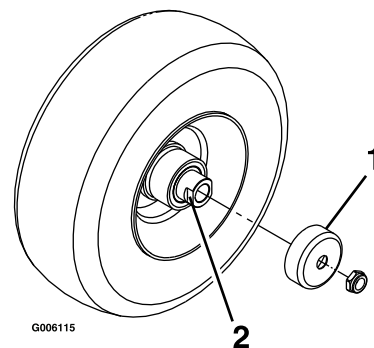

Figure 13

- Seal guard
- Spacer nut with wrench flats

- Remove caster wheel from caster forks.
- Remove seal guards from the wheel hub.

4. Remove one of the spacer nuts from the axle assembly in the caster wheel. Note that thread locking adhesive has been applied to lock the spacer nuts to the axle. Remove the axle (with the other spacer nut still assembled to it) from the wheel assembly.
5. Pry out seals, and inspect bearings for wear or damage and replace if necessary.
6. Pack the bearings with a NGLI grade #1 multi-purpose grease.
7. Insert one bearing, one new seal into the wheel.
Note: Seals (Exmark P/N 103-0063) must be replaced.
8. If the axle assembly has had both spacer nuts removed (or broken loose), apply a thread locking adhesive to one spacer nut and thread onto the axle with the wrench flats facing outward. Do Not thread spacer nut all of the way onto the end of the axle. Leave approximately 1/8 inch (3 mm) from the outer surface of the spacer nut to the end of the axle inside the nut.
9. Insert the assembled nut and axle into the wheel on the side of the wheel with the new seal and bearing.
10. With the open end of the wheel facing up, fill the area inside the wheel around the axle full of NGLI grade #1 multi-purpose grease.
11. Insert the second bearing and new seal into the wheel.
12. Apply a thread locking adhesive to the 2nd spacer nut and thread onto the axle with the wrench flats facing outward.
13. Torque the nut to 75-80 in-lb (8-9 N-m), loosen, then re-torque to 20-25 in-lb (2-3 N-m). Make sure axle does not extend beyond either nut.
14. Reinstall the seal guards over the wheel hub and insert wheel into caster fork. Reinstall caster bolt and tighten nut fully.

Important: To prevent seal and bearing damage, check the bearing adjustment often. Spin the caster tire. The tire should not spin freely (more than 1 or 2 revolutions) or have any side play. If the wheel spins freely, adjust torque on spacer nut until there is a slight amount of drag. Reapply thread locking adhesive.

Lubricate Brake Handle Pivot

Service Interval: Every 160 hours

1. Stop engine, wait for all moving parts to stop, and remove key. Engage parking brake.
2. Lubricate bronze bushings on brake handle pivot with a spray type lubricant or light oil.

Lubricate Brake Rod Bushings

Service Interval: Every 160 hours

1. Stop engine, wait for all moving parts to stop, and remove key. Engage parking brake.
2. Unhook seat latch and tilt seat up.
3. Lubricate bronze bushings on each end of brake rod shaft with a spray type lubricant or a light oil (bushings are located to the inside of the flange bearings).

Lubricate Motion Control Bronze Bushings

Service Interval: Every 160 hours

1. Stop engine, wait for all moving parts to stop, and remove key. Engage parking brake.
2. Unhook seat latch and tilt seat up.
3. Lubricate bronze bushings on flange bearings securing the motion control arm shafts with a light oil or a spray type lubricant.

Lubricate Seat Switch Actuator

Service Interval: Every 160 hours

1. Stop engine, wait for all moving parts to stop, and remove key. Engage parking brake.
2. Unhook seat latch and tilt seat up.
3. Lubricate switch actuator rod with spray type lubricant or light oil.

Check Spark Plugs

Service Interval: Every 160 hours

Remove spark plugs, check condition and reset gaps, or replace with new plugs. See Engine Owner's Manual.

Maintenance

Change Fuel Filter

Service Interval: As required

A fuel filter is installed between the fuel tanks and the engine. Replace when necessary.

Replacement Filters	
Kohler	Kohler P/N 2405010

Change Hydraulic System Filter

**Service Interval: After the first 250 hours
Yearly thereafter**

Note: Use only Exmark Part No. 109-4180 for summer use above 32°F (0°C) or Part No. 1-523541 for winter use below 32°F (0°C).

1. Stop engine, wait for all moving parts to stop, and remove key. Engage parking brake.
2. Raise seat.
3. Carefully clean area around filter. It is important that no dirt or contamination enter hydraulic system.
4. Unscrew filter to remove and allow oil to drain from reservoir.

Important: Before reinstalling new filter, fill it with Mobil 1 15W-50 and apply a thin coat of oil on the surface of the rubber seal.

Turn filter clockwise until rubber seal contacts the filter adapter, then tighten the filter an additional 2/3 to 3/4 turn.

5. Fill reservoir as stated in **Check Hydraulic Oil Level** section.
6. Raise the rear of machine up and support with jack stands (or equivalent support) just high enough to allow drive wheels to turn freely.
7. Start engine and move throttle control ahead to full throttle position. Move the speed control levers to the full speed and run for several minutes. Shut down machine and recheck oil level.

Note: Do Not change hydraulic system oil (except for what can be drained when changing filter), unless it is felt the oil has been contaminated or been extremely hot.

Changing oil unnecessarily could damage hydraulic system by introducing contaminants into the system.

Wheel Hub - Slotted Nut Torque Specification

**Service Interval: After the first 100 hours
Every 500 hours thereafter**

When tightening the slotted nut on the wheel motor tapered shaft:

1. Torque the slotted nut to 125 ft-lb (169 N-m).
2. Check distance from bottom of slot in nut to inside edge of hole. Two threads (0.1 inch) or less should be showing.
3. If more than two threads (0.1 inch) are showing remove nut and install washer (P/N 1-523157) between hub and nut.
4. Torque the slotted nut to 125 ft-lb (169 N-m).
5. Then tighten nut until the next set of slots line up with the cross hole in shaft.
6. Replace cotter pin.

Note: Do Not use anti-seize on wheel hub.

Fuel Tank — Mounting Hardware Specifications

Service Interval: As required

When installing the nuts on the fuel tank studs, fully tighten the nyloc nut and back off 1/2 turn. This allows for normal fuel tank expansion and contraction with changes in temperature and fuel levels.

Thread Locking Adhesives

Thread locking adhesives such as “Loctite 242” or “Fel-Pro, Pro-Lock Nut Type” are used on the following fasteners:

- Pump drive sheave set screws.
- Square head setscrews on Hydro pump control arms.
- Sheave retaining bolt in the end of engine crankshaft.

- Caster wheel spacer nuts.
- Fuel tank bulkhead fitting nuts.

Adhesives such as “Loctite RC/609 or RC/680” or “Fel-Pro Pro-Lock Retaining I or Retaining II” are used on the following:

Fuel tank studs, where studs are inserted into tank.

Mobil HTS Grease (Or Food-Grade Anti-seize)

Mobil HTS grease (or food-grade anti-seize) is used in the following locations:

- Between the cutter housing spindle and bearings.
- Between the jackshaft and bearings and the jackshaft and sheaves.

Copper-Based Anti-seize

Copper-based anti-seize is used in the following location:

On threads of Blade Bolts. See **Check Mower Blades** section.

Dielectric Grease

Dielectric grease is used on all blade type electrical connections to prevent corrosion and loss of contact.

Adjustments

Note: Disengage PTO, shut off engine, wait for all moving parts to stop, engage parking brake, and remove key before servicing, cleaning, or making any adjustments to the unit.

Deck Leveling

1. Position mower on a flat surface.
2. Stop engine, wait for all moving parts to stop, and remove key. Engage parking brake.
3. Check tire pressure in drive tires. Proper inflation pressure for tires is 13 psi (90 kPa). Proper inflation pressure for tires is 13 psi (90 kPa). Adjust if necessary.
4. Set anti-scalp rollers to top holes or remove them completely for this adjustment.
5. Raise the deck to the 5 inch (12.7 cm) height position (also transport position) and take all force off of the two large deck lift springs by loosening the nuts at the front of each spring (Figure 14).
6. Lower the deck to the 1 1/2 inch (3.81 cm) height position.
7. Place a 3/4 inch (19 mm) thick block of wood under each of the two rear anti- scalp roller brackets and place one under one of the front center anti-scalp roller brackets.
8. Loosen the two top chain bolts in slots in the rear deck lift arms. Loosen jam nuts and back off the socket head adjusting screws on the bottom of the arms until the chains are just loose. Turn the socket head adjusting screws in until slack is taken out of each chain. Tighten the jam nuts. Tighten the chain bolts in the deck lift arms making sure they don't move while tightening.
9. Loosen the four nuts which secure the front swivels (two per side) until the front chains are loose and front of deck is supported by the 3/4 inch (19 mm) block. Do Not loosen the front chain hardware.
10. On left side, adjust front swivel using the locking nut behind the swivel until the front chain is tight and all slack is removed from linkage. Do Not lift front of deck off 3/4 inch (19 mm) block. Secure front swivel using locking nut in front of swivel. Repeat for right side.
11. Recheck that the 3/4 inch (19 mm) blocks fit just snugly under the brackets and that the tension on

Maintenance

all the chains is approximately equal. Make sure all chain attachment bolts are tight. Reposition anti-scalp rollers and tighten securely.

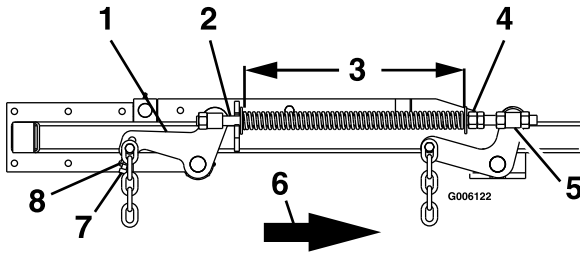

Figure 14

1. Apply downward pressure here
2. Place locking pliers here to hold spring
3. 10 1/2 inches (26.7 cm)
4. Remove force on deck springs by loosening nuts here
5. Swivel
6. Front of unit
7. Socket head adjusting screw
8. Jam nut

12. Raise deck lift lever to the 5 inch (12.7 cm) cutting height position (Figure 8). Adjust spring compression until proper distance is obtained between the two large washers (Figure 14). Adjustment is made by turning the nut at the front of each spring (clockwise will shorten the spring, counterclockwise will lengthen the spring). Lock in position with jam nuts.

Note: When above adjustments have been made, the front of the deck will be slightly lower than the rear of the deck.

Pump Drive Belt Tension

Self-tensioning - No adjustment necessary.

Mule Drive Belt Tension Adjustment

Self-tensioning idler, adjust as follows:

1. Stop engine, wait for all moving parts to stop, and remove key. Engage parking brake.
2. Check to make sure the center of the bolt head in the center of the spring loaded pulley, on left side engine deck support, is positioned between the centers of the two alignment holes in the left support plate (Figure 15 and Figure 16). It is necessary to adjust the belt tension when the

center of the bolt head is at or below the center of the bottom alignment hole.

3. When adjustment is necessary, loosen the idler pulley on the right-hand side so it can move up and down in the slot.

Place a wrench on the 3/8 inch nut in the center of the spring loaded pulley and apply upward pressure to relieve tension on the spring (a 1/2 inch drive breaker bar and 9/16 inch socket works best).

Reposition the adjusting pulley to the bottom of the slot.

Note: When installing a new belt, it is necessary to reposition the right adjusting pulley upward in the slot in order to position the center of the spring loaded pulley between the alignment holes.

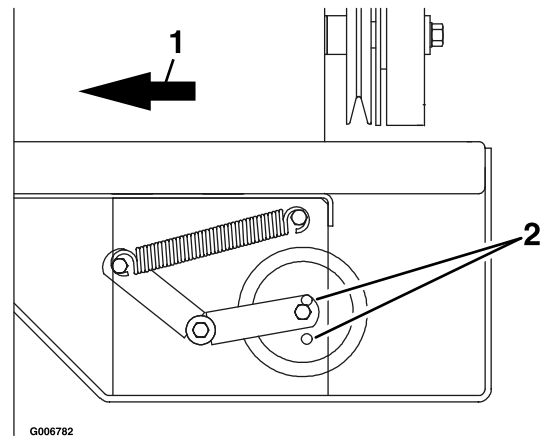

Figure 15

1. Front of unit
2. Alignment holes

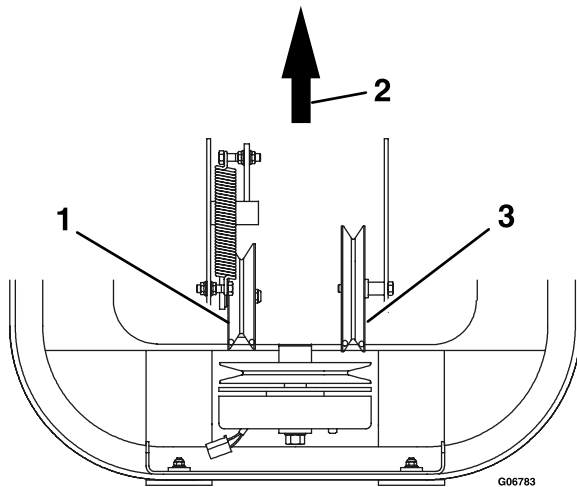

Figure 16

- 1. Spring idler pulley
- 2. Front of unit
- 3. Right side idler pulley (adjustable)

Deck Belt Tension

Self-tensioning - No adjustment necessary.

Belt Guide Adjustment

1. Stop engine, wait for all moving parts to stop, and remove key. Engage parking brake.
2. Remove the belt shield on the right side of mower deck.
3. Note belt guide bolted to deck near the shield support stud and right-hand pulley. Guide should be 1/8 inch (3.2 mm) away from the belt, with bolt-end of guide near end of slot (Figure 17).
4. If adjustment is necessary, loosen the bolt securing the belt guide and make proper adjustment. Tighten hardware.

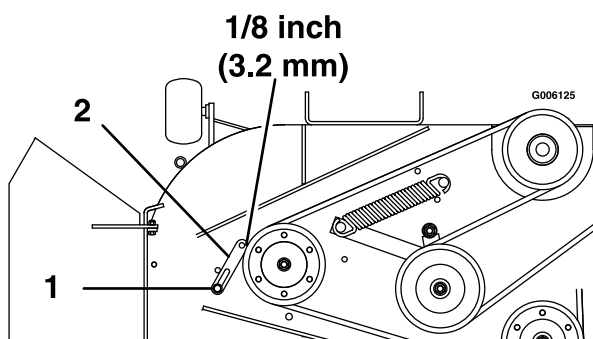

Figure 17

- 1. End of slot
- 2. Belt guide

Brake Link Adjustment

Check to make sure brake is adjusted properly.

1. Disengage brake lever (lever down).
2. Measure the length of the spring. Measurement should be 2 3/4 inches (7.0 cm) between washers. (Figure 18).
3. If adjustment is necessary, tighten the nut directly below the yoke and loosen the bottom nut (bottom one of the two tightened together) below the spring. Turn the nut directly below the washer (top nut of the two tightened together) until the correct measurement is obtained. Tighten the two nuts together and repeat on opposite side of unit. Turn clockwise to shorten spring length and turn counterclockwise to lengthen the spring.

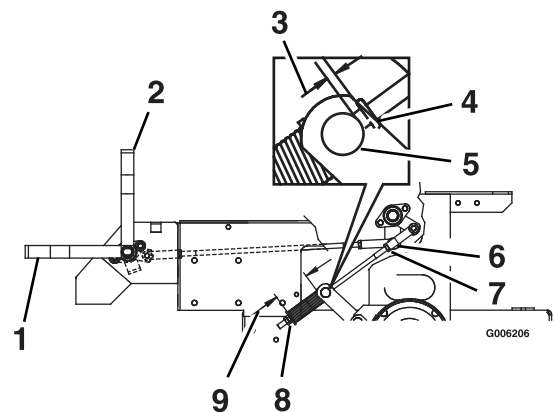

Figure 18

- 1. Lever down (disengaged)
- 2. Lever up (engaged)
- 3. 1/4 to 5/16 inch (6.4 to 7.9 mm)
- 4. Collar
- 5. Trunnion roller
- 6. Yoke
- 7. Lock nut
- 8. Spring adjustment
- 9. 2 3/4 inches (7.0 cm)

Brake Adjustment

1. Check for brake link 2 3/4 inches (7.0 cm) measurement as described in the **Brake Link Adjustment** section.
2. Engage the brake lever (lever up). The space between the trunnion roller and the rod collar should measure 1/4 inch to 5/16 inch (6.4–7.9 mm).
3. If adjustment is necessary, loosen nut above the trunnion roller. Adjust the nyloc nut under the trunnion roller until distance listed above exists.

Maintenance

between the spring retainer bracket and the adjacent nyloc nut. Tighten the jam nut above the trunnion roller.

4. If adjustment is necessary, loosen the nut directly below the yoke. Turn the bottom nut (below washer) until the correct measurement is obtained (see Figure 18) turn nut clockwise to lengthen the gap (screws rod into yoke) and turn counterclockwise to shorten the gap (screws rod out of yoke). Tighten nut against yoke and check opposite side of unit, repeat if necessary. Lengthen (or shorten) the brake rod until the correct gap can be achieved by following steps 2 and 3.

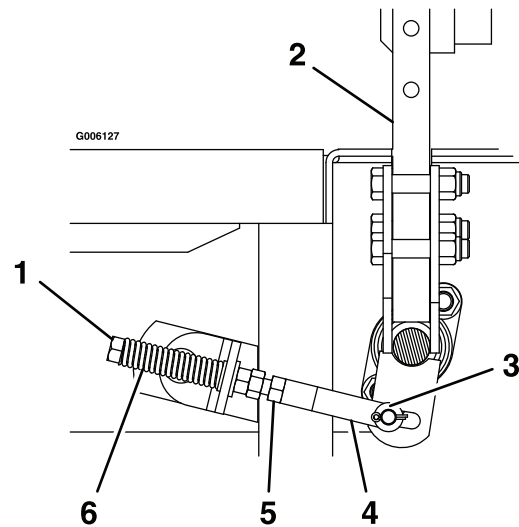

Figure 19

- | | |
|----------------------------|----------------------|
| 1. Turn bolt here | 4. Yoke |
| 2. Lever centered in notch | 5. Loosen here |
| 3. End of slot | 6. Reverse indicator |

Electric Clutch Adjustment

No adjustment necessary.

Reverse Indicator Adjustment

1. Stop engine, wait for all moving parts to stop, and remove key. Engage parking brake.
2. Unhook seat latch and tilt seat forward.
3. Begin with either the left or right motion control lever. Move lever to the neutral position and pull lever back until the clevis pin (on arm below pivot shaft) contacts the end of the slot (just beginning to put pressure on spring). (Figure 19).
4. Check where lever is relative to notch in console (should be centered allowing lever to pivot outward to the neutral lock position).
5. If adjustment is needed, loosen the nut against the yoke and while applying slight rearward pressure on the motion control lever, turn the head of the adjustment bolt in the appropriate direction until lever is centered (keeping rearward pressure on the lever will keep the pin at the end of the slot and allow the adjustment bolt to move the lever to the appropriate position). Tighten lock nut.
6. Repeat on opposite side of unit.

Motion Control Linkage Adjustment

⚠ WARNING

Engine must be running and drive wheels must be turning so motion control adjustment can be performed. Contact with moving parts or hot surfaces may cause personal injury

Keep fingers, hands, and clothing clear of rotating components and hot surfaces.

⚠ CAUTION

Raising the mower deck for service or maintenance relying solely on mechanical or hydraulic jacks could be dangerous. The mechanical or hydraulic jacks may not be enough support or may malfunction allowing the unit to fall, which could cause injury.

Do Not rely solely on mechanical or hydraulic jacks for support. Use adequate jack stands or equivalent support

1. This adjustment must be made with the drive wheels turning. First raise the frame and block up so that drive wheels can rotate freely.
2. Remove the electrical connection from the seat safety switch, located directly to the left of the seat switch assembly beside the hydraulic oil reservoir.
3. **Temporarily** install a jumper wire across the terminals in the connector of the main wiring harness.
4. Run the unit at least 5 minutes with the drive levers at full forward speed to bring hydraulic system oil up to operating temperature.
5. Unhook seat latch and tilt seat forward.
6. Loosen lock nuts from the ball joints at each end of the pump control linkage (Figure 20).

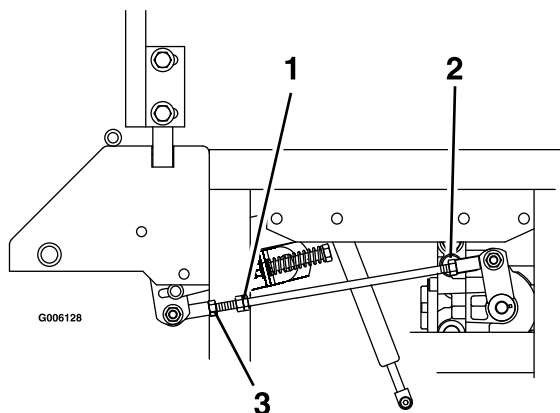

Figure 20

Left-Hand Side of Unit

- | | |
|-----------------------------------|------------------------------------|
| 1. Turn here to adjust | 3. Loosen here (right-hand thread) |
| 2. Loosen here (left-hand thread) | |

7. Start engine. **Brake must be engaged and motion control levers out to start engine. Operator does not have to be in the seat because of the jumper wire being used.** Run engine at full throttle and release brake.
8. The reverse indicator spring must be correct before the following adjustments can be made. See the **Reverse Indicator Adjustment** section.

Note: The motion control lever needs to be in neutral while making any necessary adjustments.
9. Bring the motion control lever into the neutral position. Adjust pump control rod length by rotating the double nuts on the rod in the

appropriate direction until the wheels slightly creep in reverse (Figure 20). Move the motion control lever to the reverse position and while applying slight pressure to the lever allow the reverse indicator spring to bring the levers back to neutral. The wheel must stop turning or slightly creep in reverse. When adjustment is complete, tighten lock nuts onto ball joints.

10. Adjustment for the RH motion control lever: Bring the RH motion control lever into the neutral position.

Adjust the RH pump control rod length by rotating the double nuts on the rod in the appropriate direction until the wheels slightly creep in reverse. Move the motion control lever to the reverse position and while applying slight pressure to the lever allow the reverse indicator spring to bring the levers back to neutral. The wheel must stop turning or slightly creep in reverse (Figure 21).

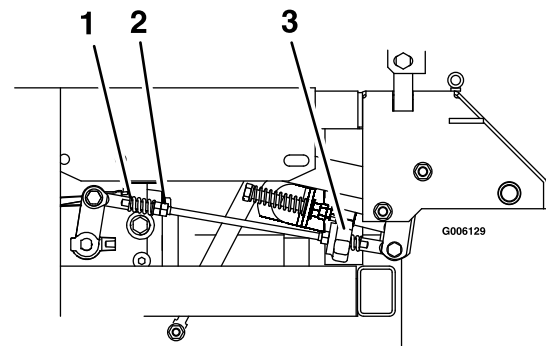

Figure 21

Right-Hand Side of Unit

- | | |
|------------------------------------|-----------------------------------|
| 1. Loosen here (right-hand thread) | 3. Loosen here (left-hand thread) |
| 2. Turn here to adjust | |

11. Shut off unit. Remove jumper wire from wire harness connector and plug connector into seat switch.

Motion Control Damper Adjustment

The top damper mounting bolt can be adjusted to obtain a more desired motion control lever resistance. See Figure 22 for mounting options.

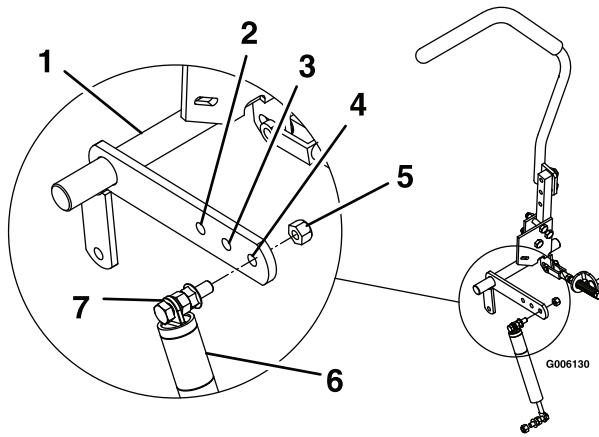

Figure 22

1. Motion control bracket
2. Least resistance (softest feel)
3. Medium resistance (medium feel)
4. Most resistance (firmest feel)
5. Torque nyloc nut to 200 in-lb (16.7 ft-lb). Bolt must protrude past end of nyloc nut after torque.
6. Damper
7. Damper must move freely on bolt.

Adjust Seat Switch

1. If necessary, adjust the seat actuator rod length to where the machine will shut off when the operator raises off the seat (with brake disengaged or PTO engaged) but will continue to run with operator in seat (a slight shift in weight should not shut machine off).

Normal adjustment is when length of spring is 2.09 inches (5.3 cm) (with seat up).

Note: To prevent the engine from cutting out when operating over rough ground, the unit is equipped with a time-delayed seat switch. When the operator raises off the seat with either the brake disengaged or the PTO engaged, the engine should stop after 1/2 second has elapsed.

2. To adjust seat switch actuator rod length, loosen lock nut on bottom of the actuator rod (5/16 x 7 inch bolt) and adjust the nuts to move the actuator plate/washer up or down on the rod, then retighten.

Caster Pivot Bearings Pre-Load Adjustment

Remove dust cap from caster and tighten nyloc nut until washers are flat and back off 1/4 of a turn to properly set the pre-load on the bearings. If disassembled, make sure the spring disc washers are reinstalled as shown in Figure 23.

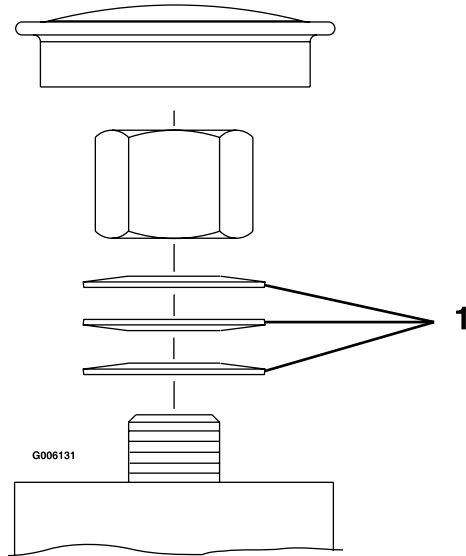

Figure 23

1. Spring disc washers

Cleaning

Clean Engine Cooling System

Service Interval: Before each use or daily (May be required more often in dry or dirty conditions.)

⚠ CAUTION

Excessive debris around the engine cooling air intake and inside of the pump drive belt compartment and damaged or missing rubber baffles can cause the engine and hydraulic system to overheat which can create a fire hazard.

Clean all debris from inside of pump drive belt compartment daily.

1. Stop engine, wait for all moving parts to stop, and remove key. Engage parking brake.
2. Clean all debris from rotating engine air intake screen and from around engine shrouding.
3. Clean all debris from inside of pump drive belt compartment.
4. Inspect rubber engine baffles for proper fit. Replace if necessary.

Remove Engine Shrouds and Clean Cooling Fins

Service Interval: Every 80 hours

1. Stop engine, wait for all moving parts to stop, and remove key. Engage parking brake.
2. Remove cooling shroud clean-out covers from engine and clean cooling fins. Also clean dust, dirt, and oil from external surfaces of engine, which can cause improper cooling.
3. Make sure cooling shroud clean-out covers are reinstalled. Operating the engine without cooling shroud clean-out covers will cause engine damage due to overheating.

Clean Grass Build-Up Under Deck

Service Interval: Before each use or daily

1. Stop engine, wait for all moving parts to stop, and remove key. Engage parking brake.
2. Raise deck to the transport (5 inch (12.7 cm) cutting height) position. Lift the front of unit and support unit using jack stands or equivalent support.

⚠ CAUTION

Raising the mower deck for service or maintenance relying solely on mechanical or hydraulic jacks could be dangerous. The mechanical or hydraulic jacks may not be enough support or may malfunction allowing the unit to fall, which could cause injury.

Do Not rely solely on mechanical or hydraulic jacks for support. Use adequate jack stands or equivalent support.

3. Clean out any grass build-up from underside of deck and in discharge chute.

Waste Disposal

Motor Oil Disposal

Engine oil and hydraulic oil are both pollutants to the environment. Dispose of used oil at a certified recycling center or according to your state and local regulations.

Battery Disposal

⚠ DANGER

Battery electrolyte contains sulfuric acid, which is poisonous and can cause severe burns. Swallowing electrolyte can be fatal or if it touches skin can cause severe burns.

- Wear safety glasses to shield eyes, and rubber gloves to protect skin and clothing when handling electrolyte.
- Do Not swallow electrolyte.

Maintenance

Federal law states that batteries should not be placed in the garbage. Management and disposal practices must be within relevant federal, state, or local laws.

If a battery is being replaced or if the unit containing the battery is no longer operating and is being scrapped, take the battery to a local certified recycling center. If no local recycling is available return the battery to any certified battery reseller.

Troubleshooting

Important: It is essential that all operator safety mechanisms be connected and in proper operating condition prior to mower use.

When a problem occurs, do not overlook the simple causes. For example: starting problems could be caused by an empty fuel tank.

The following table lists some of the common causes of trouble. Do not attempt to service or replace major items or any items that call for special timing of adjustments procedures (such as valves, governor, etc.). Have this work done by your **Engine Service Dealer**.

Note: When disconnecting electrical connectors DO NOT pull on the wires to separate the connectors.

Problem	Possible Cause	Corrective Action
Starter does not crank	<ol style="list-style-type: none"> 1. PTO is engaged. 2. Parking brake is not. 3. Drive levers are not in neutral lock position. 4. Battery does not have a full charge. 5. Electrical connections are corroded, loose or faulty. 6. Fuse is blown. 7. Relay or switch is defective. 	<ol style="list-style-type: none"> 1. Disengage the PTO. 2. Set the parking brake. 3. Ensure the drive levers are in the neutral lock position. 4. Charge the battery. 5. Check the electrical connections for good contact. Clean connector terminals thoroughly with electrical contact cleaner, apply dielectric grease and reconnect. 6. Replace the blown fuse. 7. Contact an Authorized Service Dealer.
Engine will not start, starts hard, or fails to keep running	<ol style="list-style-type: none"> 1. Fuel tank is empty. 2. Fuel shutoff valve is closed. 3. Oil level in the crankcase is low. 4. The throttle and choke are not in the correct position. 5. Dirt in fuel filter. 6. Dirt, water, or stale fuel is in the fuel system. 7. Air cleaner is dirty. 8. Seat switch is not properly adjusted. 9. Electrical connections are corroded, loose or faulty. 10. Relay or switch is defective. 11. Faulty spark plug. 12. Spark plug wire is not connected. 	<ol style="list-style-type: none"> 1. Fill the fuel tank. 2. Open the fuel shutoff valve. 3. Add oil to the crankcase. 4. Be sure the throttle control is midway between the "SLOW" and "FAST" positions, and the choke is in the "ON" position for a cold engine or the "OFF" position for a warm engine. 5. Replace the fuel filter. 6. Contact an Authorized Service Dealer. 7. Clean or replace the air cleaner element. 8. Adjust the seat switch. 9. Check the electrical connections for good contact. Clean connector terminals thoroughly with electrical contact cleaner, apply dielectric grease and reconnect. 10. Contact an Authorized Service Dealer. 11. Clean, adjust or replace spark plug. 12. Check the spark plug wire connection.
Engine loses power	<ol style="list-style-type: none"> 1. Engine load is excessive 2. Air cleaner is dirty. 3. Oil level in the crankcase is low. 4. Cooling fins and air passages for the engine are plugged. 5. Vent hole in the fuel cap is plugged. 6. Dirt in fuel filter. 7. Dirt, water, or stale fuel is in the fuel system. 	<ol style="list-style-type: none"> 1. Reduce the ground speed. 2. Clean or replace the air cleaner element. 3. Add oil to the crankcase. 4. Remove the obstructions from the cooling fins and air passages. 5. Clean or replace the fuel cap. 6. Replace the fuel filter. 7. Contact an Authorized Service Dealer.

Troubleshooting

Problem	Possible Cause	Corrective Action
Engine overheats	<ol style="list-style-type: none"> 1. Engine load is excessive 2. Oil level in the crankcase is low. 3. Cooling fins and air passages for the engine are plugged. 	<ol style="list-style-type: none"> 1. Reduce the ground speed. 2. Add oil to the crankcase. 3. Remove the obstructions from the cooling fins and air passages.
Mower pulls left or right (with levers fully forward)	<ol style="list-style-type: none"> 1. Tracking needs adjustment 2. Tire pressure in drive tires not correct. 3. Reverse indicator and motion control linkage need adjustment. 	<ol style="list-style-type: none"> 1. Adjust the tracking. 2. Adjust tire pressure in the drive tires. 3. Adjust the reverse indicator and the motion control linkage.
Machine does not drive	<ol style="list-style-type: none"> 1. Bypass valve is not closed tight. 2. Drive or pump belt is worn, loose or broken. 3. Drive or pump belt is off a pulley. 4. Broken or missing idler spring. 5. Hydraulic fluid level is low or too hot. 	<ol style="list-style-type: none"> 1. Tighten the bypass valve. 2. Change the belt. 3. Change the belt. 4. Replace the spring. 5. Add hydraulic fluid to reservoir or let it cool down.
Uneven cutting height.	<ol style="list-style-type: none"> 1. Blade(s) not sharp. 2. Cutting blade(s) is/are bent. 3. Mower deck is not level. 4. Underside of mower is dirty. 5. Tire pressure in drive tires not correct. 6. Blade spindle bent. 7. Tips of adjacent blades are at an uneven cutting height. Blades tips should be even within 3/16 inch which is approximately one blade thickness. 	<ol style="list-style-type: none"> 1. Sharpen the blade(s). 2. Install new cutting blade(s). 3. Level mower deck from side-to-side and front-to-rear. 4. Clean the underside of the mower. 5. Adjust tire pressure in the drive tires. 6. Contact an Authorized Service Dealer. 7. Replace blades, spindles and (or) check for damage to mower deck.
Abnormal vibration	<ol style="list-style-type: none"> 1. Cutting blade(s) is/are bent or unbalanced. 2. Blade mounting bolt is loose. 3. Engine mounting bolts are loose. 4. Loose engine pulley, idler pulley, or blade pulley. 5. Engine pulley is damaged. 6. Blade spindle is bent. 	<ol style="list-style-type: none"> 1. Install new cutting blade(s). 2. Tighten the blade mounting bolt. 3. Tighten the engine mounting bolts. 4. Tighten the appropriate pulley. 5. Contact an Authorized Service Dealer. 6. Contact an Authorized Service Dealer.
Blades do not rotate.	<ol style="list-style-type: none"> 1. Drive belt is worn, loose or broken. 2. Drive belt is off pulley. 3. Deck belt is worn, loose or broken. 4. Deck belt is off pulley. 5. Broken or missing idler spring. 	<ol style="list-style-type: none"> 1. Check the belt tension. 2. Install drive belt and check adjusting shafts and belt guides for correct position. 3. Install new deck belt. 4. Install deck pulley and check the idler pulley, idler arm and spring for correct position and function. 5. Replace the spring.

Schematics

Electrical Diagram

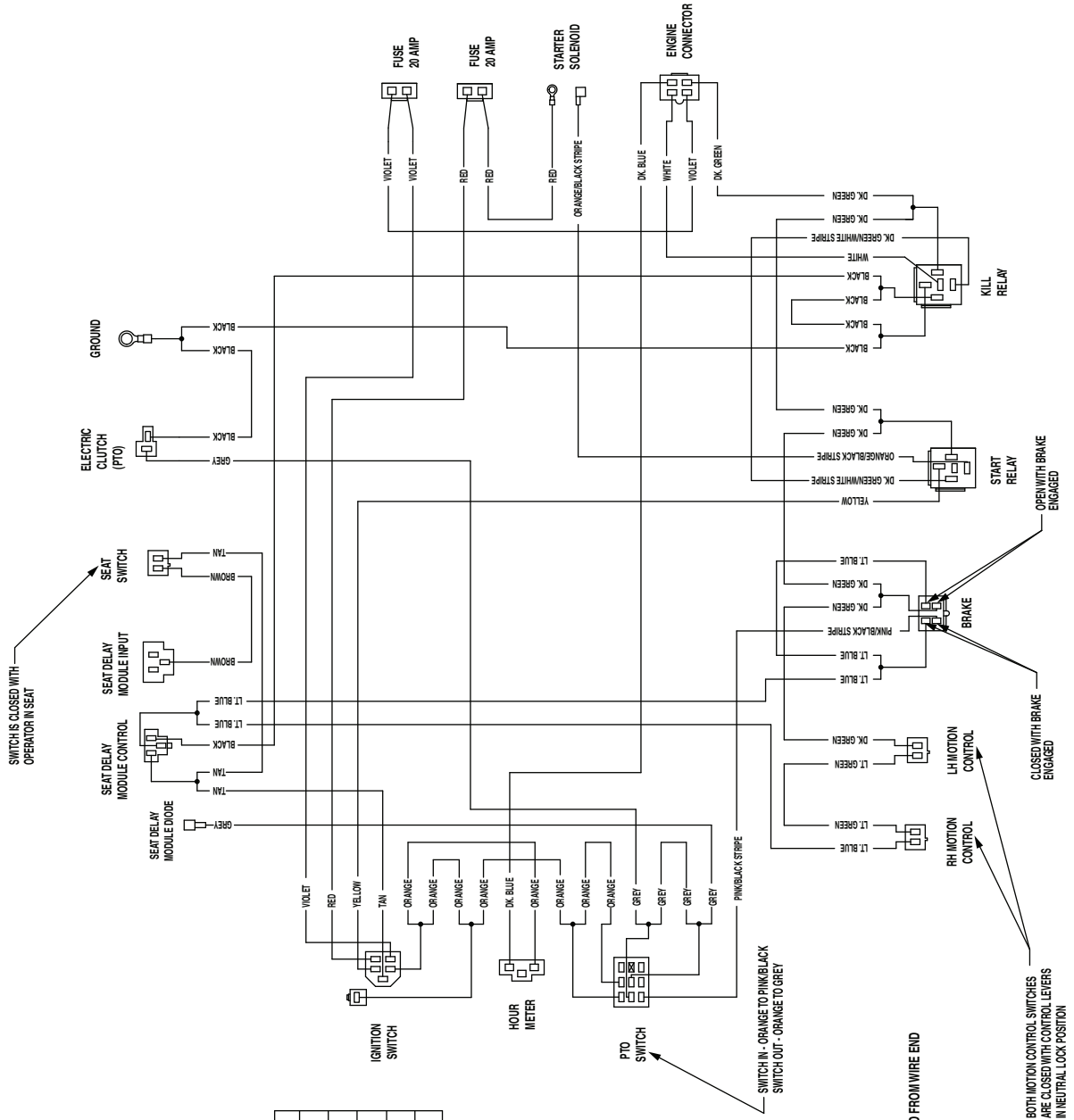

IGNITION SWITCH	CONNECTIONS
TERMINAL A	VOLTAGE REGULATOR
TERMINAL B	BATTERY
TERMINAL I	HOUR METER, ENGINE, PTO SWITCH
TERMINAL S	START RELAY
TERMINAL X	SEAT DELAY
TERMINAL Y	HOUR METER, ENGINE, PTO SWITCH

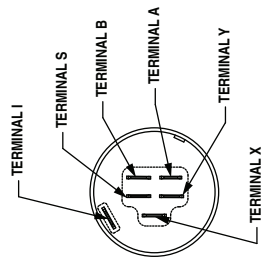

POSITION	CIRCUIT "MAKE"
1. OFF	NONE
2. RUN	B + I + A X + Y
3. START	B + I + S

G006132

NOTE:
CONNECTORS VIEWED FROM WIRE END

BOTH MOTION CONTROL SWITCHES
ARE CLOSED WITH CONTROL LEVERS
IN NEUTRAL LOCK POSITION

Hydraulic Diagram

AS VIEWED FROM
REAR OF UNIT

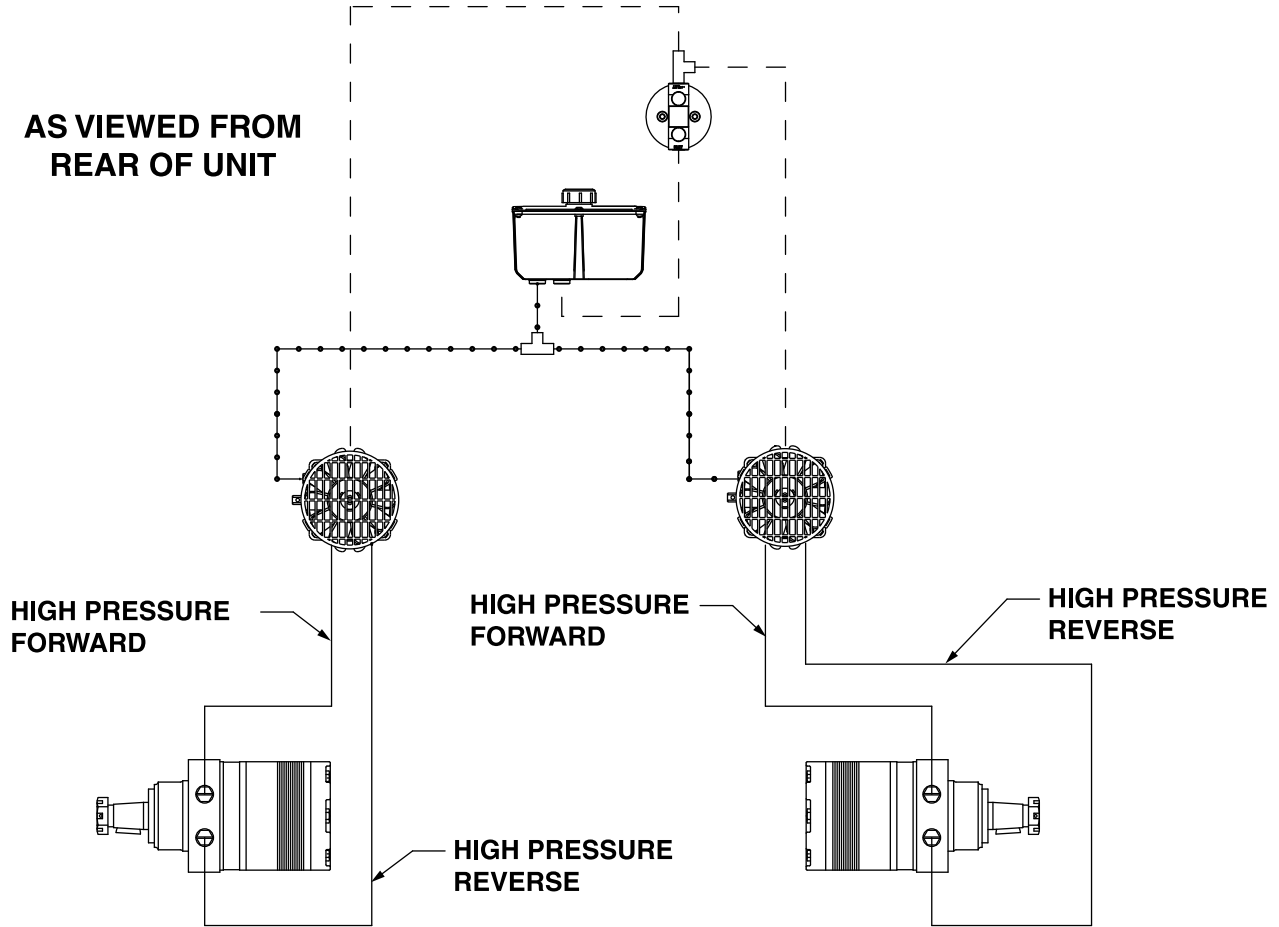

- HIGH PRESSURE
- - - CHARGE PUMP INLET
- · · · CASE DRAIN

G006791

2-Year Limited Warranty Exmark Turf Equipment

(For units purchased on or after October 1, 2004)

Conditions and Products Covered

Exmark Mfg. Co. Inc. and its affiliate, Exmark Warranty Company, pursuant to an agreement between them, jointly warrant on the terms and conditions herein, that we will repair, replace or adjust any part manufactured by Exmark and found by us (in the exercise of our reasonable discretion) to be defective in factory materials or workmanship for a period of two years.

This warranty applies to Exmark turf equipment purchased on or after October 1, 2004 sold in the US or Canada. This warranty may only be assigned or transferred to a second (or third) owner by an authorized Exmark dealer. The warranty period commences upon the date of the original retail purchase.

<u>Products</u>	<u>Warranty Period</u>
• All Products (except as noted below)	2 years
• All Attachments and Accessories	1 year
• Metro 21 and Metro 26 Series	1 year
• Belts and Tires	90 days
• Battery	1 Year Prorated
• Engine* Warranty is covered by engine manufacturer	

* Please refer to the engine manufacturer's warranty statement that is included in the literature packet. We are not authorized to handle warranty adjustments on engines.

This warranty only includes the cost of parts and labor.

Items and Conditions Not Covered

This warranty does not cover the following:

- Pickup and delivery charges to and from any authorized Exmark Service Dealer beyond first warrantable service.
- Any damage or deterioration due to normal use, wear and tear, or exposure.
- Cost of regular maintenance service or parts, such as filters, fuel, lubricants, tune-up parts, and adjustments.
- Any product or part which has been altered or misused or required replacement or repair due to normal wear, accidents, or lack of proper maintenance.
- Any repairs necessary due to use of parts, accessories or supplies, including gasoline, oil or lubricants, incompatible with the turf equipment or other than as recommended in the operator's manual or other operational instructions provided by Exmark.

There are no other express warranties except for engine and special emission system coverage stated elsewhere herein or included with the product.

All warranty work must be performed by an authorized Exmark Service Dealer using Exmark approved replacement parts.

Instructions for Obtaining Warranty Service

The product must be registered with original proof of purchase by an Exmark Service Dealer before obtaining any warranty service.

Contact any Exmark Service Dealer to arrange service at their dealership. To locate a dealer convenient to you, access our website at www.exmark.com. U.S. Customers may also call 402-223-6375.

If for any reason you are dissatisfied with the Service Dealer's analysis or with the assistance provided, contact us at:

Exmark Customer Service Department
The Exmark Warranty Company
2101 Ashland Avenue
Beatrice, NE 68310
402-223-6375 or
service@exmark.com

Owner's Responsibilities

The Exmark turf equipment, including any defective part, must be returned to an authorized Exmark service dealer within the warranty period. This warranty extends only to turf equipment operated under normal conditions. You must read the operator's manual. You must also properly service and maintain your Exmark product as described in the operator's manual. Such routine maintenance, whether performed by a dealer or by you, is at your expense.

General Conditions

The sole liability of Exmark and Exmark Warranty Company with respect to this warranty shall be repair and replacement of defective components as set forth herein. Neither Exmark nor Exmark Warranty Company shall have any liability for any other cost, loss or damage, including but not limited to, any incidental or consequential loss or damage.

In particular, we shall have no liability or responsibility for:

- Expenses related to gasoline, oil or lubricants.
- Travel time, overtime, after hours time or other extraordinary repair charges or charge relating to repairs or replacements outside of normal business hours at the place of business of the authorized Exmark Service Dealer.
- Rental of like or similar replacement equipment during the period of any warranty, repair or replacement work.
- Any telephone or telegram charges or travel charges.
- Loss or damage to person or property other than that covered by the terms of this warranty.
- Any claims for lost revenue, lost profit or additional cost as a result of a claim of breach of warranty.
- Attorney's fees.

No Claim of breach of warranty shall be cause for cancellation or rescission of the contract of sale of any Exmark mower.

Some states do not allow exclusions of incidental or consequential damages, so the above exclusions and limitations may not apply to you.

This warranty gives you specific legal rights, and you may also have other rights which vary from state to state.

G006117

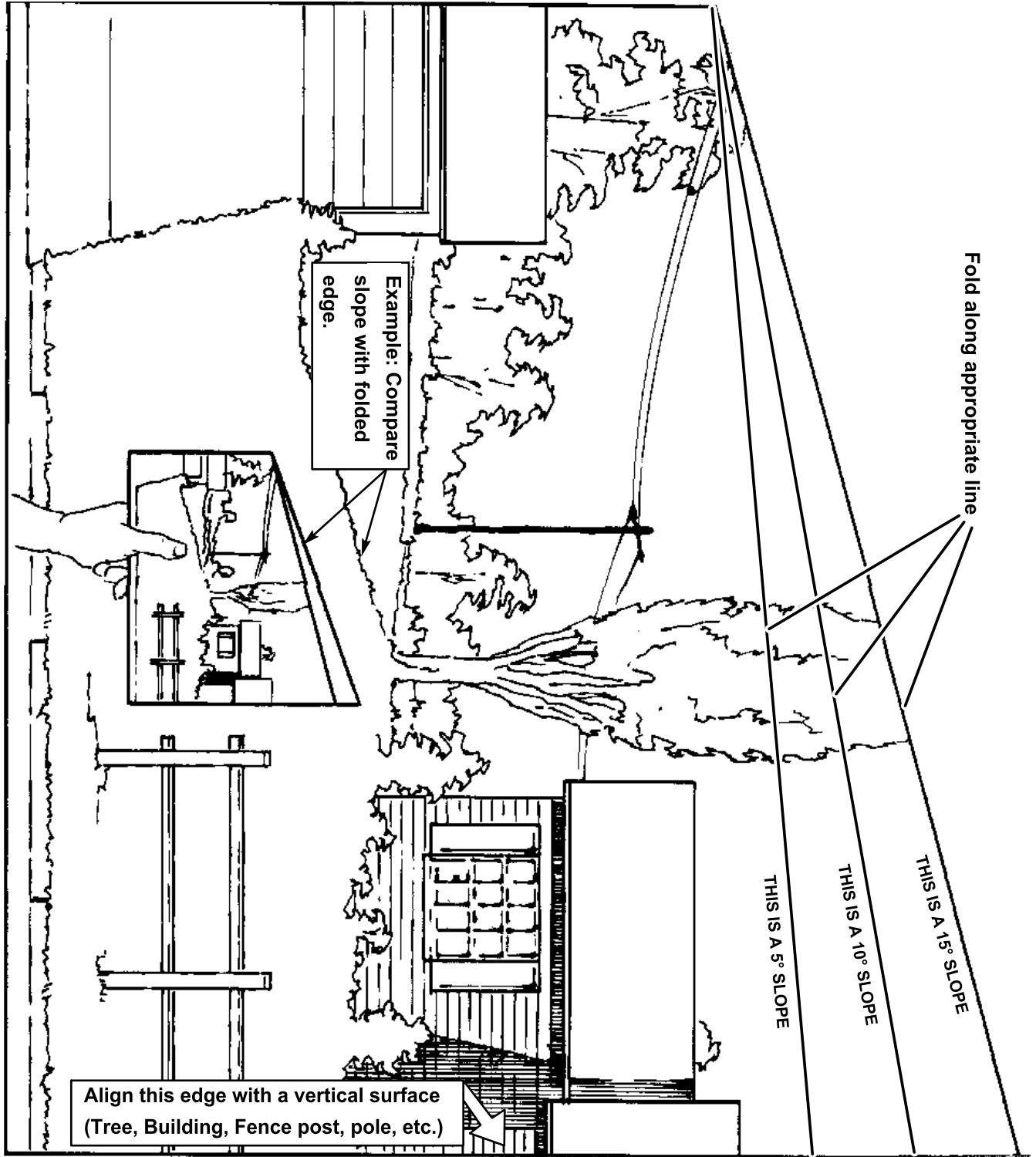

See Exmark's Complete Line of Accessories

Riding Accessories

Custom Ride Seat Suspension System
Deck Lift Assist Kit
Hitch Kit
Light Kit
Micro-mulch System
Roll Over Protection System (ROPS)
Snow Blade
Sun Shade
Trash Container
Turf Striper
Ultra Vac Collection System
Ultra Vac Quick Disposal System

Walk Behind Accessories

Grass Catcher
Micro-mulch System
Steerable Sulky
Sulky Hitch Kit
Turf Striper
Standon

**Check Us Out On The Web:
www.exmark.com**