

Installing the ExtremeWireless Outdoor AP3965

Electrical Hazard: Only qualified personnel should perform installation procedures.

Overview of the AP3965

The AP3965 enables you to extend your Wireless LAN beyond the boundaries of indoor locations. It is resistant to harsh outdoor conditions and extreme temperatures (Operating Temp. -40°C-60°C). Using the advanced wireless distribution mesh feature of Wireless LAN, the AP3965 can extend your Wireless LAN to outdoor locations without Ethernet cabling. Mounting brackets are provided for quick and easy mounting of the AP to walls and poles.

Note: In this Quick Reference, any reference to AP3965 applies to both AP3965 an “i” model (with internal antennas) and an “e” model (with external antennas).

Figure 1 AP3965 Top View

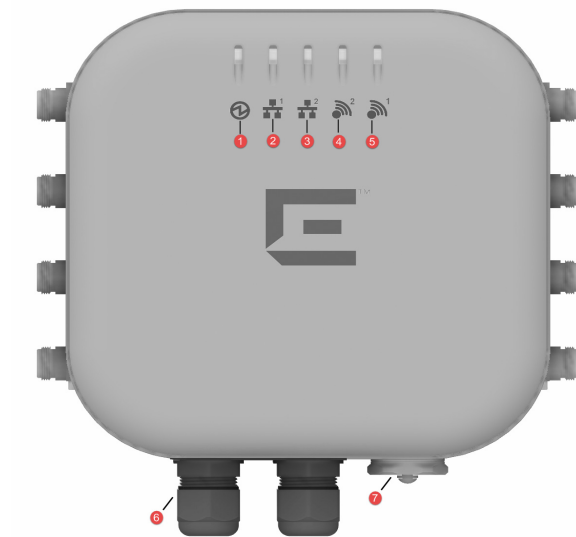

- | | |
|----------------------|---|
| 1 Status | 5 Radio 1 (5 GHz) |
| 2 LAN 1 (Ethernet 1) | 6 LAN Ports (POE):
LAN 1 PDE Port
LAN 2 PSE Port output of DC48V, 0.26A |
| 3 LAN 2 (Ethernet 2) | 7 Console Port and Reset Button |
| 4 Radio 2 (2.4 GHz) | |

Warning: Always install and torque all LAN and Console caps properly, regardless of installation site location.

AP3965 models have the following specifications:

- Radios: 2 radios (2.4 GHz and 5 GHz)
- LEDs: 5 (see Figure 1)
- Power: 802.3at (PoE+) compliant
- The AP3965 supports the 802.11ac and 802.11n wireless standards, with full backward compatibility with legacy 802.11a, and 802.11b/g. The AP3965 with external antenna connectors supports a variety of antennas. (External antennas must be ordered separately.)
- The AP3965 interoperates fully with Wireless LAN, including support for VoWLAN, branch office mode, guest services, RTLS, availability and mobility features.
- Mounting brackets for a wall or pole mount
- Enabled for use with an ExtremeCloud™ entitlement.

Note: All radio and LAN ports are labeled on the AP3965.

For detailed installation information about the AP3965, see the *ExtremeWireless AP3965i/e Installation Guide*.

Unpacking the AP3965

The AP3965 box includes a cardboard separation.

- 1 Unpack the AP3965 from its carton.
- 2 Verify the contents of the carton as listed in Table 1.

Table 1 Contents of the AP3965

Quantity	Item
1	AP3965 Quick Reference
1	WS-AP3965i/e model that you ordered.
Under the cardboard separation:	
1	H” shaped bracket that is used for mounting the AP.
1	Metal bracket for attaching the AP to a pole, pipe, or mast.
1	#10AWG ground wire with a ring terminal crimped on it (6 foot length)
The following hardware is included:	
4	Additional hex nuts for the concrete anchors.
4	Concrete wall anchor assemblies that include the anchors, a flat washer, and a hex nut.
4	Split washer for the concrete anchors.
4	Cable clamps, all are ½” wide. Two clamps accommodate a 2.5” maximum diameter pole and two clamps accommodate a 6”-7” diameter pole.
8	Screw assemblies, size M4, that include the screws, flat washers, and split washers.
1	Ground Screw assembly, size M4, that include the screw, star washer, and split washer.

Optional: You may also need antennas, terminators, or cables. Refer to www.extremenetworks.com/support for product numbers.

Note: Before mounting the AP3965, read the “RF Safety Distance” on page 2.

Mounting the AP3965

Use these instructions as guidelines for mounting and connecting the AP3965 easily and safely. The installation of the AP3965 should be performed by a professional installer to ensure proper operation and compliance with local safety guidelines.

Attach the AP3965 to a surface that can support it and withstand its environment. It can be mounted to a wall, girder, ceiling, or pole, and the surface material can be concrete, brick, wood, metal, or plastic.

Positioning the AP for Installation

Mount the AP so that the glands are on the side of the AP closest to the ground, and not above the plastic cover. You must provide a 3-inch drip loop on all cables.

Attach the Ground Wire

Use the M4 ground screw assembly, with the star washer, to attach the ground wire’s ring terminal to the back of the AP. The wire should be as close to the AP bottom as possible. Tighten the screw to a torque of 12.0 in-lbs.

Mounting the AP3965 to a Wall

- 1 Using the mounting bracket as a guide, mark the location for the mounting screws. The wall bracket provides 8 attachment holes. Use 4 (1 in each corner), Place the bracket and mark the 4 hole centers.
- 2 Drill four holes into the wall as follows:
 - for installing the AP on a masonry wall, use a 5/16” diameter bit.
 - for other materials, use the appropriate drill for the screws being used.
- 3 For masonry installations, drill at least 1/8” [3MM] past the depth of the screw, or bolt, being used, and place four anchor assemblies into the holes.
- 4 Attach the AP to the “H” Bracket:

- a Use 4 M4 screw assemblies to attach the AP to the “H” bracket on the side that does *not* have the PEM stand-offs.
 - b Tighten the four screws to a torque of 12.0 in-lbs.
- 5 Secure the anchors to the wall, then secure the bracket to the anchors.
 - 6 If using #10 screws, tighten them to a torque of 25 in-lbs. If using ¼” screws, tighten them to 45 in-lbs.

Figure 2 AP3965 Wall Mount “H” Bracket

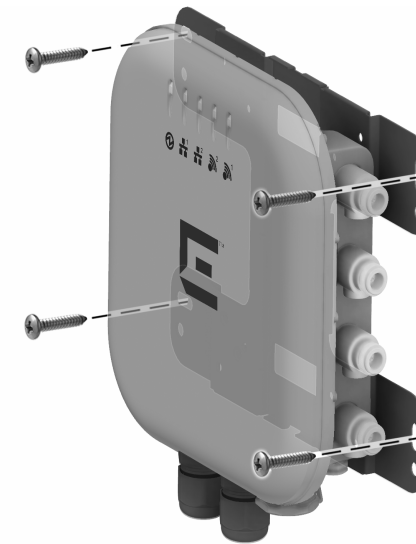

Mounting the AP3965 to a Pole

- 1 Determine the diameter of the pole.

Pole Diameter	Cable Clamp Size
<= 2.5” [63.5mm],	Use small cable clamp.
6” - 7” (178mm)	Use large cable clamp

For other pole diameters, provide your own stainless steel cable clamp. The band must be ½” [12.7mm] wide.

- 2 Attach the AP to the “H” bracket on the side that does not have the PEM stand-offs. Tighten the four screws to a torque of 12.0 in-lbs.
- 3 Using four M4 screw assemblies, attach the pole bracket onto the “H” bracket. Tighten the screws to 12.0 in-lbs.

Figure 3 Attaching Pole Mount to “H” Bracket

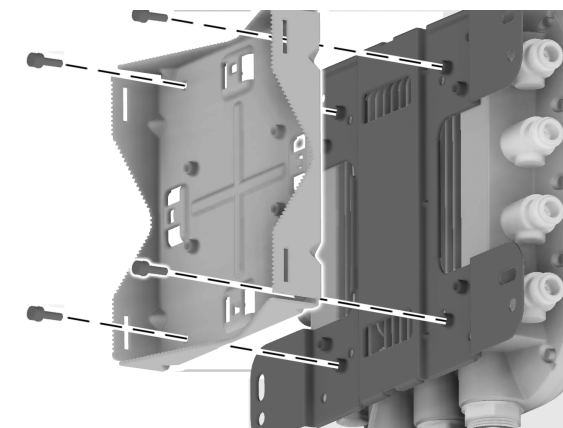

- 4 Attach the cable clamp to the pole bracket. Open the cable clamp by turning a flat bladed screwdriver counterclockwise. Then, insert the non-clamp end into the pole bracket through the holes.

Note: It is easier to install both clamps before attaching to the pole.

- 5 Put the metal band around the pole and insert it into the clamp. Turn the clamp screw clockwise, tightening the band around the pole.

Figure 4 AP with Mounting Bracket—Horizontal Position

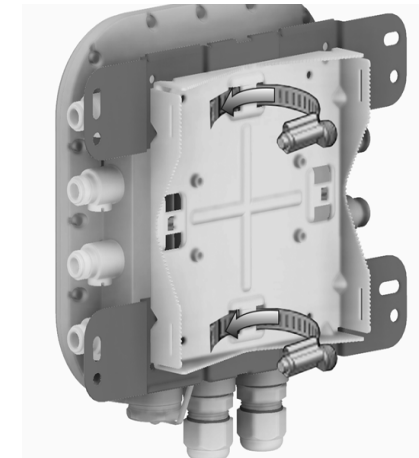
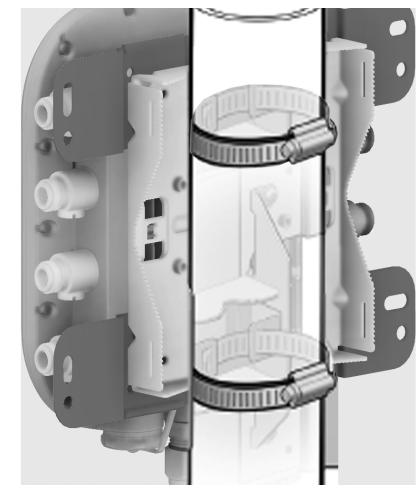

Figure 5 AP3965 Pole Mount—Vertical Pole



Installing External Antennas

- 1 Professionally install the external antennas intended for area coverage. For information about antenna selection and installation, refer to the *External Antenna Site Preparation and Installation Guide*.
- 2 Attach the external antenna cables to the Standard Polarity Type-N connectors on the AP3965.

Connecting & Powering the AP3965

You can power up the AP3965 using Power over Ethernet based on 802.3at (PoE+) compliant switch or PoE+ injector.

- The PoE injector must be 802.3at compliant. The PoE injector is not provided with the AP.

Note: When the AP3965 is powered by the Power Injector, the DATA port of the Injector should be connected to a non PoE switch or, if the switch is PoE capable, PoE must be DISABLED on the DATA port.

- A waterproof RJ45 connector is provided to connect the PoE injector to the AP3965. You must connect the RJ45 connector to the RJ45 cable. For instructions, refer to the *ExtremeWireless Outdoor AP3965 Installation Guide*.

Notice

Copyright © 2016 Extreme Networks, Inc. All Rights Reserved.

Legal Notices

Extreme Networks, Inc. reserves the right to make changes in specifications and other information contained in this document and its website without prior notice. The reader should in all cases consult representatives of Extreme Networks to determine whether any such changes have been made.

The hardware, firmware, software or any specifications described or referred to in this document are subject to change without notice.

Trademarks

Extreme Networks and the Extreme Networks logo are trademarks or registered trademarks of Extreme Networks, Inc. in the United States and/or other countries.

All other names (including any product names) mentioned in this document are the property of their respective owners and may be trademarks or registered trademarks of their respective companies/owners.

For additional information on Extreme Networks trademarks, please see: www.extremenetworks.com/company/legal/trademarks/

Documentation & Support

For product support, including documentation, visit:

www.extremenetworks.com/support/

Extreme Networks, Inc.
145 Rio Robles
San Jose, CA 19534
Tel: +1 408-579-2800
Toll-free: +1 888-257-3000

Regulatory and Compliance Information

Federal Communications Commission (FCC) Notice:

This device complies with Part 15 of the FCC rules. Operation is subject to the following two conditions: (1) this device may not cause harmful interference, and (2) this device must accept any interference received, including interference that may cause undesired operation.

This equipment has been tested and found to comply with the limits for a Class A digital device, pursuant to Part 15 of the FCC Rules. These limits are designed to provide reasonable protection against harmful interference when the equipment is operated in a commercial environment. This equipment generates, uses, and can radiate radio frequency energy, and, if not installed and used in accordance with the instruction manual, may cause harmful interference to radio communications. Operation of this equipment in a residential area is likely to cause harmful interference in which case the user will be required to correct the interference at his own expense.

Industry Canada Notice:

This device complies with Industry Canada license-exempt RSS standard(s). Operation is subject to the following two conditions: (1) this device may not cause interference, and (2) this device must accept any interference, including interference that may cause undesired operation of the device.

Le présent appareil est conforme aux CNR d'Industrie Canada applicables aux appareils radio exempts de licence. L'exploitation est autorisée aux deux conditions suivantes : (1) l'appareil ne doit pas produire de brouillage, et (2) l'utilisateur de l'appareil doit accepter tout brouillage radioélectrique subi, même si le brouillage est susceptible d'en compromettre le fonctionnement.

This radio transmitter (IC: 4141B-4411OAC) has been approved by Industry Canada to operate with the antenna types listed below with the maximum permissible gain and required antenna impedance for each antenna type indicated. Antenna types not included in this list, having a gain greater than the maximum gain indicated for that type, are strictly prohibited for use with this device.

Le présent émetteur radio (IC: 4141B-4411AC) a été approuvé par Industrie Canada pour fonctionner avec les types d'antenne énumérés ci-dessous et ayant un gain admissible maximal et l'impédance requise pour chaque type d'antenne. Les types d'antenne non inclus dans cette liste, ou dont le gain est supérieur au gain maximal indiqué, sont strictement interdits pour

l'exploitation de l'émetteur.:

Antennas for the AP 3965e			Antenna Gain	
Part No. (Short Description)	Frequency Band	Antenna Type	2.4G Gain	5G Gain
30711 (WS-AO-DQ05120N)	2.4G/5G	Sector	5.5	5.5
30712 (WS-AO-5Q04060N)	5G	Sector	N/A	4
30713 (WS-AO-2Q05060N)	2.4G	Sector	5	N/A
30714 (WS-AO-DE07025N)	2.4G/5G	Sector	7.5	6.5
30715 (WS-AO-DE13025N)	2.4G/5G	Sector	13	12
30716 (WS-AO-5Q05025N)	5G	Sector	N/A	4.5
30717 (WS-AO-5Q11025N)	5G	Sector	N/A	11.5
30718 (WS-AO-DE10055N)	2.4G/5G	Sector	10.5	7.5
30720 (WS-AO-DE07100N)	2.4G/5G	Panel	7	6
30724 (WS-AO-DQ04360N)	2.4/5G	Omni	5.5	6
WS-AO-5D23009N (WS-AO-5D23009N)	5G	Sector	N/A	23

Note: All antennas use Standard Polarity Type-N connectors.

The antennas used for this transmitter must be installed to provide a separation distance of at least 39 cm (150cm for WS-AO-5D23009N) from all persons and must not be co-located or operating in conjunction with another antenna or transmitter.

Cet équipement est conforme aux limites d'exposition aux rayonnements IC établies pour un environnement non contrôlé. Cet équipement doit être installé et utilisé avec un minimum de 39 cm (150cm pour WS-AO-5D23009N) de distance entre la source de rayonnement et votre corps.

Dynamic Frequency Selection (DFS) for devices operating in the bands 5250- 5350 MHz, 5470-5600 MHz and 5650-5725 MHz

Sélection dynamique de fréquences (DFS) pour les dispositifs fonctionnant dans les bandes 5250-5350 MHz, 5470-5600 MHz et 5650-5725 MHz

This device may not be operated in the band 5150-5250 MHz outdoors. This band is restricted to indoor use only to reduce potential harmful interference to co-channel mobile satellite systems.

Ce dispositif ne peut pas être utilisé dans la bande 5150-5250 MHz à l'extérieur. Cette bande est limitée à une utilisation en intérieur afin de réduire les interférences nuisibles potentiel de co- canal avec les systèmes mobiles par satellite.

The maximum antenna gain permitted for devices in the bands 5250-5350 MHz and 5470-5725 MHz shall be such that the equipment still complies with the e.i.r.p. limit.

le gain maximal d'antenne permis pour les dispositifs utilisant les bandes 5250-5350 MHz et

5470-5725 MHz doit se conformer à la limite de p.i.r.e.

The maximum antenna gain permitted for devices in the band 5725-5850 MHz shall be such that the equipment still complies with the e.i.r.p. limits specified for point-to-point and non-point-to-point operation as appropriate.

le gain maximal d'antenne permis (pour les dispositifs utilisant la bande 5725-5850 MHz)

doit se conformer à la limite de p.i.r.e. spécifiée pour l'exploitation point à point et non point à point, selon le cas.

For product available in the USA/Canada market, only channel 1-11 can be operated. Selection of other channels is not possible.

Pour les produits disponibles aux États-Unis / Canada du marché, seul le canal 1 à 11 peuvent être exploités. Sélection d'autres canaux n'est pas possible.

High-power radars are allocated as primary users (i.e. priority users) of the bands 5250-5350 MHz and 5650-5850 MHz and that these radars could cause interference and/or damage to LE-LAN devices.

Les radars à haute puissance sont désignés comme utilisateurs principaux (c. utilisateurs prioritaires) des bandes 5250-5350 MHz et 5650-5850 MHz et que ces radars pourraient provoquer des interférences et / ou endommager les appareils LE- LAN.

Refer to the *ExtremeWireless Outdoor AP3965 Installation Guide*, Appendix B, "Regulatory Information," for complete regulatory information.

RF Safety Distance

AP3965e, FCC ID: QXO-4411OAC

The antennas used for this transmitter must be installed to provide a separation distance of at least 39 cm (150cm for WS-AO-5D23009N) from all persons and must not be co-located or operating in conjunction with another antenna or transmitter.

AP3965i, FCC ID: QXO-4411OU

The antennas used for this transmitter must be installed to provide a separation distance of at least 20 cm from all persons and must not be co-located or operating in conjunction with another antenna or transmitter.

Safety Guidelines

This section contains notices that you must adhere to ensure your personal safety and to prevent any damage to the equipment.

Grounding Warning:



Warning: To operate the ExtremeWireless Outdoor AP3965 safely, the chassis ground connector must have a suitable cable connected. Do not use the ExtremeWireless Outdoor AP3965 without a ground cable connected.

Qualified Personnel:



Electrical Hazard: Only qualified personnel should perform installation procedures. Within the context of the safety notes in this documentation qualified persons are defined as persons who are authorized to commission, ground and label devices, systems and circuits in accordance with established safety practices and standards. A qualified person understands the requirements and risks involved with installing outdoor electrical equipment in accordance with national codes.

Lightning Protection Warning:



Warning: Antennas installed outdoors must be within the area covered by a lightning protection system. Make sure that all conducting systems entering from outdoors can be protected by a lightning protection potential equalization system. When implementing your lightning protection concept, make sure you adhere to the VDE 0182 or IEC 62305 standard.

The AP3965 has a built-in lightning protector; no external lightning protector is required. You must, however, note that the lightning protector is not an adequate protection against a lightning strike. The lightning protector only works within the framework of a comprehensive lightning protection concept. If you have questions, ask a qualified specialist company.

European Waste Electrical and Electronic Equipment (WEEE) Notice



In accordance with Directive 2012/19/EU of the European Parliament on waste electrical and electronic equipment (WEEE):

- The symbol above indicates that separate collection of electrical and electronic equipment is required.
 - When this product has reached the end of its serviceable life, it cannot be disposed of as unsorted municipal waste. It must be collected and treated separately.
 - It has been determined by the European Parliament that there are potential negative effects on the environment and human health as a result of the presence of hazardous substances in electrical and electronic equipment.
 - It is the users' responsibility to utilize the available collection system to ensure WEEE is properly treated.
- For information about the available collection system, please contact Extreme Customer Support at 353 61 705500 (Ireland).

产品说明书附件 Supplement to Product Instructions

部件名称 (Parts)	有毒有害物质或元素 (Hazardous Substance)					
	铅 (Pb)	汞 (Hg)	镉 (Cd)	六价铬 (Cr ⁶⁺)	多溴联苯 (PBB)	多溴二苯醚 (PBDE)
金属部件 (Metal Parts)	×	○	○	×	○	○
电路模块 (Circuit Module)	×	○	○	×	○	○
电缆及电缆组件 (Cables & Cable Assemblies)	×	○	○	×	○	○
塑料和聚合物部件 (Plastic and Polymeric parts)	○	○	○	○	○	×
电路开关 (Circuit Breakers)	○	○	×	×	○	○

○: 表示该有毒有害物质在该部件所有均质材料中的含量均在 SJ/T 11363-2006 标准规定的限量要求以下。
Indicates that the concentration of the hazardous substance in all homogeneous materials in the parts is below the relevant threshold of the SJ/T 11363-2006 standard.

×: 表示该有毒有害物质至少在该部件的某一均质材料中的含量超出 SJ/T 11363-2006 标准规定的限量要求。
Indicates that the concentration of the hazardous substance of at least one of all homogeneous materials in the parts is above the relevant threshold of the SJ/T 11363-2006 standard.

对销售之日的所售产品, 本表显示, 机创供应链的电子产品信息可能包含这些物质。注意: 在所售产品中可能会也可能不会含有所有列出的部件。
This table shows where these substances may be found in the supply chain of Extreme electronic information products, as of the date of sale of the enclosed product. Note that some of the component types listed above may or may not be a part of the enclosed product.

除非另外特别的标注, 此标志为针对所涉及产品的环保使用期标志。某些零部件会有一个不同的环保使用期(例如, 电池单元模块)贴在其产品上。此环保使用期限只适用于产品是在产品手册中所规定的条件下工作。 The Environmentally Friendly Use Period (EFUP) for all enclosed products and their parts are per the symbol shown here, unless otherwise marked. Certain parts may have a different EFUP (for example, battery modules) and so are marked to reflect such. The Environmentally Friendly Use Period is valid only when the product is operated under the conditions defined in the product manual.	
--	--

NCC Statement

- 「經型式認證合格之低功率射頻電機, 非經許可, 公司、商號或使用者均不得擅自變更頻率、加大功率或變更原設計之特性及功能」。
- 「低功率射頻電機之使用不得影響飛航安全及干擾合法通信; 經發現有干擾現象時, 應立即停用, 並改善至無干擾時方得繼續使用。前項合法通信, 指依電信法規定作業之無線電通信。低功率射頻電機須忍受合法通信或工業、科學及醫療用電波輻射性電機設備之干擾」。
- 「電磁波曝露量MPE標準值1mW/cm²本產品使用時建議應距離人體: 58cm」。
- 固定式點對點操作, 不包括點對多點系統、全方向性應用及多台共站發射機傳送相同資訊。
- 「本器材須經專業工程人員安裝及設定, 始得設置使用, 且不得直接販售給一

Hazardous Substances

This product complies with the requirements of Directive 2011/65/EU of the European Parliament and of the Council of 8 June 2011 on the restriction of the use of certain hazardous substances in electrical and electronic equipment.

Declaration of Conformity in Languages of the European Community

Hereby, Extreme Networks, Inc. declares that the radio equipment type Wireless LAN Access Point is in compliance with Directive 1999/5/EC. The full text of the EU declaration of conformity is available at the following Internet address:

<http://www.extremenetworks.com/>



Note: Changes or modifications made to this device which are not expressly approved by the party responsible for compliance could void the user's authority to operate the equipment.

ExtremeWireless™ Access Points

Quick Reference

P/N 31016 WS-AP3965i-FCC

P/N 31017 WS-AP3965i-ROW

P/N 31018 WS-AP3965e-FCC

P/N 31019 WS-AP3965e-ROW