



BlackDiamond 12800 Series Switches Hardware Installation Guide

BlackDiamond 12802 Switch

BlackDiamond 12804 Switch

Extreme Networks, Inc.
3585 Monroe Street
Santa Clara, California 95051
(888) 257-3000
(408) 579-2800
<http://www.extremenetworks.com>

Published: June 2008
Part number: 104002-00 Rev. 03



AccessAdapt, Alpine, Altitude, BlackDiamond, EPICenter, Essentials, Ethernet Everywhere, Extreme Enabled, Extreme Ethernet Everywhere, Extreme Networks, Extreme Standby Router Protocol, Extreme Turbodrives, Extreme Velocity, ExtremeWare, ExtremeWorks, ExtremeXOS, Go Purple Extreme Solution, ScreenPlay, Sentries, ServiceWatch, Summit, SummitStack, Triumph, Unified Access Architecture, Unified Access RF Manager, UniStack, the Extreme Networks logo, the Alpine logo, the BlackDiamond logo, the Extreme Turbodrives logo, the Summit logos, the Powered by ExtremeXOS logo, and the Color Purple, among others, are trademarks or registered trademarks of Extreme Networks, Inc. or its subsidiaries in the United States and/or other countries.

Adobe, Flash, and Macromedia are registered trademarks of Adobe Systems Incorporated in the U.S. and/or other countries. AutoCell is a trademark of AutoCell. Avaya is a trademark of Avaya, Inc. Internet Explorer is a registered trademark of Microsoft Corporation. Mozilla Firefox is a registered trademark of the Mozilla Foundation. sFlow is a registered trademark of sFlow.org. Solaris and Java are trademarks of Sun Microsystems, Inc. in the U.S. and other countries.

Specifications are subject to change without notice.

All other registered trademarks, trademarks, and service marks are property of their respective owners.

© 2007, 2008 Extreme Networks, Inc. All Rights Reserved.

For safety compliance information, see [Appendix A, "Safety Information."](#)

Table of Contents

Preface	9
Introduction	9
Conventions.....	9
Related Publications	10
Part 1: BlackDiamond 12800 Series Switches	
Chapter 1: About the BlackDiamond 12800 Series Switches	15
Overview of the BlackDiamond 12800 Series Switches	15
Full-Duplex Support	15
Management Ports	16
External Compact Flash Memory Card	16
BlackDiamond 12804 Switch Chassis.....	16
BlackDiamond 12802 Switch Chassis.....	18
Chapter 2: BlackDiamond 12800 Series Modules	19
Overview of the BlackDiamond 12800 Series Modules.....	19
BlackDiamond 12800 Series MSMs.....	20
Software Requirements.....	20
Redundant MSM Activity (BlackDiamond 12804 Switch).....	21
MSM LEDs	21
Features of the BlackDiamond 12800 MSMs.....	22
BlackDiamond 12800 Series I/O Modules	23
I/O Module LEDs.....	24
Port LEDs on I/O Modules	24
GM-20T I/O Module	25
GM-20T LEDs.....	25
GM-20XT and GM-20XTR I/O Modules	25
GM-20XT and GM-20XTR LEDs.....	26
XM-2X and XM-2XR I/O Modules	26
XM-2X and XM-2XR LEDs	27
XM-2HR I/O Module	28
XM-2HR LEDs	28
Chapter 3: Extreme Networks Power Supply Units for BlackDiamond Switches	29
Overview of BlackDiamond 12800 Series Power Supplies	29
Extreme Networks 1200 W DC PSU	30
Minimum Software Required	31
LEDs.....	31
Extreme Networks 700/1200 W AC PSU	32
LEDs.....	33
Power Supply Cords.....	33
Fuse	33
Specifications.....	34

Extreme Networks 325 W DC Power Supply	34
Minimum Software Required	35
LEDs.....	35
Fuse	36
Specifications.....	36
Extreme Networks 325 W AC Power Supply	36
LEDs.....	37
Replacing AC Power Supply Cords	37
Fuse	38

Part 2: Installing BlackDiamond Switches and Modules

Chapter 4: Site Preparation.....	41
Planning Your Site	41
Meeting Site Requirements.....	42
Operating Environment Requirements	42
Building and Electrical Codes.....	42
Wiring Closet Considerations	43
Temperature	43
Humidity	44
BlackDiamond Family Chassis Spacing Requirements.....	44
Airflow Requirements	44
Electrostatic Discharge	45
Rack Specifications and Recommendations	46
Mechanical Recommendations for the Rack.....	46
Protective Grounding for the Rack.....	46
Space Requirements for the Rack	47
Securing the Rack.....	47
Evaluating and Meeting Cable Requirements	48
Cabling Standards.....	48
Cable Labeling and Record Keeping.....	48
Installing Cable.....	49
Fiber Optic Cable	50
Cable Distances	51
RJ-45 Connector Jackets	52
Radio Frequency Interference.....	53
Meeting Power Requirements	53
Power Supply Requirements.....	53
AC Power Cable Requirements.....	54
Replacing the Power Cable.....	54
Uninterruptible Power Supply Requirements	54
Selecting a UPS.....	55
Calculating Volt-Amperage Requirements.....	55
UPS Transition Time	55
Applicable Industry Standards.....	55
Chapter 5: Installing the BlackDiamond 12800 Series Chassis	57
Unpacking the BlackDiamond 12804 Chassis.....	58
Rack-Mounting the BlackDiamond 12804 Chassis	60
Pre-installation Requirements.....	61

Attaching the BlackDiamond 12804 Mid-Mount Brackets	61
Rack-Mounting the BlackDiamond 12804 Chassis	62
Unpacking the BlackDiamond 12802 Chassis.....	64
Rack-Mounting the BlackDiamond 12802 Chassis	66
Required Tools and Equipment.....	66
Front-Mounting a BlackDiamond 12802 Chassis.....	66
Mid-Mounting a BlackDiamond 12802 Chassis.....	67
Grounding the BlackDiamond 12800 Series Chassis	68
Initial Management Access	70
Connecting Equipment to the Console Port.....	70
Logging In for the First Time	71
Chapter 6: Installing Power Supply Units	73
Safety	73
BlackDiamond PSU Compatibility.....	74
Extreme Networks 1200 W DC PSU	74
Minimum Software Required	75
Pre-Installation Requirements	75
Installing the DC Wiring.....	75
Installing an Extreme Networks 1200 W DC PSU	76
Removing an Extreme Networks 1200 W DC PSU.....	79
Front Panel LEDs	80
Extreme Networks 700/1200 W AC PSU	81
Pre-Installation Requirements	81
Installing an Extreme Networks 700/1200 W AC PSU.....	81
Removing an Extreme Networks 700/1200 W AC PSU.....	83
Front Panel LEDs	84
Power Supply Cords.....	84
Fuse	85
Using the BlackDiamond12804 AC Power Cord Retainer Channel.....	85
Pre-Installation Requirements	85
Installing the BlackDiamond 12804 AC Power Cord Retainer Channel.....	85
Removing the BlackDiamond 12804 AC Power Cord Retainer Channel.....	88
Extreme Networks 325 W DC Power Supply	88
Minimum Software Required	88
Pre-Installation Requirements	89
Installing the DC Wiring.....	89
Installing an Extreme Networks 325 W DC PSU	90
Removing an Extreme Networks 325 W DC PSU.....	93
LEDs.....	94
Extreme Networks 325 W AC Power Supply	94
Pre-Installation Requirements	94
Installing an Extreme Networks 325 W AC PSU	95
Installing Retaining Brackets and Connecting Power.....	97
Removing an Extreme Networks 325 W AC PSU.....	99
Front Panel LEDs	99
Power Supply Cords.....	100
Fuse	100
Chapter 7: Installing Modules and Connecting Cables	101

Module Slot Assignments.....	101
Distinguishing a BlackDiamond 12800 Series MSM from an I/O Module	102
Installing a BlackDiamond 12800 Series Module	102
Making Network Interface Cable Connections.....	105
Installing a Backup MSM.....	105
Verifying the Module Installation	106
Displaying Slot Status Information	106
Removing a BlackDiamond 12800 Series Module	106
BlackDiamond Series Blank Front Panels	108
Installing a Blank Front Panel	108
Removing a Blank Front Panel.....	109
Installing or Removing an External Compact Flash Memory Card.....	111

Part 3: BlackDiamond Maintenance Procedures

Chapter 8: Replacing BlackDiamond 12800 Series Chassis Components..... 115

Safety Information	115
Replacing a BlackDiamond 12804 PSU/Fan Controller	115
Pre-Installation Requirements	116
Removing a BlackDiamond 12804 PSU/Fan Controller	116
Installing a Replacement BlackDiamond 12804 PSU/Fan Controller	117
Replacing a BlackDiamond 12802 PSU/Fan Controller	118
Pre-installation Requirements.....	118
Removing a BlackDiamond 12802 PSU/Fan Controller	118
Installing the Replacement PSU/Fan Controller	119
Replacing a BlackDiamond 12804 Fan Tray	119
Pre-Installation Requirements	119
Removing the Fan Tray	120
Installing the Replacement BlackDiamond 12804 Fan Tray	121
Replacing the BlackDiamond 12802 Fan Tray	121
Pre-installation Requirements.....	122
Removing the BlackDiamond 12802 Fan Tray	122
Installing the Replacement BlackDiamond 12802 Fan Tray	123

Chapter 9: Repacking a BlackDiamond Chassis..... 125

Safety Information	125
Repacking the BlackDiamond 12804 Chassis.....	126
Repacking the BlackDiamond 12802 Chassis.....	129

Part 4: Appendixes

Appendix A: Safety Information 133

Considerations Before Installing	133
Installing Power Supply Units.....	134
Maintenance Safety.....	135
General Safety Precautions	135
Cable Routing for LAN Systems	136
PoE Devices	136

Selecting Power Supply Cords	136
Battery Replacement and Disposal.....	138
Fiber Optic Ports—Optical Safety	138
GBIC, SFP (Mini-GBIC), XENPAK, and XFP Regulatory Compliance	139
Appendix B: Technical Specifications	147
BlackDiamond 12804 Switch.....	147
BlackDiamond 12802 Switch.....	149
Power Supplies for the BlackDiamond 12800 Series Switches	151
Connector Pinouts.....	153
Index	155

Preface

This preface provides an overview of this guide, describes guide conventions, and lists other publications that might be useful.



WARNING!

Service to all equipment should be performed by trained and qualified service personnel only. Before installing or removing any components of the system, or before carrying out any maintenance procedures, you must thoroughly read the safety information provided in [Appendix A](#) of this guide. Failure to follow this safety information can lead to personal injury or damage to the equipment.

Introduction

This guide provides the required information to install Extreme Networks® BlackDiamond® 12800 series switches. This guide also contains information about site preparation, switch functionality, and switch operation.

This guide is intended for use by network administrators responsible for installing and setting up network equipment. It assumes a basic working knowledge of:

- Local area networks (LANs)
- Ethernet concepts
- Ethernet switching and bridging concepts
- Routing concepts
- Simple Network Management Protocol (SNMP)

See the *ExtremeXOS 12.0 Concepts Guide* and the *ExtremeXOS 12.0 Command Reference Guide* for information about configuring Extreme Networks BlackDiamond 12800 series switches.



NOTE

If the information in the installation note or release note shipped with your Extreme Networks switch differs from the information in this guide, follow the installation or release note.

Conventions

[Table 1](#) and [Table 2](#) list conventions used throughout this guide.

Table 1: Notice icons



Icon	Notice Type	Alerts you to...
	Note	Important features or instructions.
	Caution	Risk of personal injury, system damage, or loss of data.
	Warning	Risk of severe personal injury.

Table 2: Text conventions

Convention	Description
Screen displays	This typeface represents information as it appears on the screen, or command syntax.
The words “enter” and “type”	When you see the word “enter” in this guide, you must type something, and then press the Return or Enter key. Do not press the Return or Enter key when an instruction simply says “type.”
[Key] names	Key names appear in text in one of two ways: <ul style="list-style-type: none"> • Referenced by their labels, such as “the Return key” or “the Escape key” • Written with brackets, such as [Return] or [Esc] If you must press two or more keys simultaneously, the key names are linked with a plus sign (+). Example: Press [Ctrl]+[Alt]+[Del].
Words in italicized type	Italics emphasize a point of information or denote new terms at the place where they are defined in the text.

Related Publications

The Extreme Networks ExtremeXOS™ switch documentation set includes:

- *ExtremeXOS 12.0 Concepts Guide*
- *ExtremeXOS 12.0 Command Reference Guide*
- *ExtremeXOS 12.0 Release Notes*
- *BlackDiamond 8800 Series Switches Hardware Installation Guide*
- *BlackDiamond 10808 Switch Hardware Installation Guide*
- *Summit Family Switches Hardware Installation Guide*
- *Extreme Networks Pluggable Interfaces Hardware Installation Guide*

Documentation for Extreme Networks products is available from the Extreme Networks website at the following location:

<http://www.extremenetworks.com/services/documentation>

You can select and download the following Extreme Networks documentation from the Documentation Overview page:

- Software User Guides
- Hardware User Guides

You can find archived user guides for software at:

<http://www.extremenetworks.com/services/documentation/swuserguides.asp>

You can also find archived installation guides for hardware at:

<http://www.extremenetworks.com/services/documentation/hwuserguides.asp>

1

BlackDiamond 12800 Series Switches

1

About the BlackDiamond 12800 Series Switches

This chapter includes the following sections:

- [Overview of the BlackDiamond 12800 Series Switches on page 15](#)
- [BlackDiamond 12804 Switch Chassis on page 16](#)
- [BlackDiamond 12802 Switch Chassis on page 18](#)

For information about the I/O modules and management modules (MSMs) for the BlackDiamond 12800 series switches, see [Chapter 3, “BlackDiamond 12800 Series Modules.”](#)

For information about installing the BlackDiamond switches, see [Chapter 2, “Installing the BlackDiamond 12800 Series Chassis.”](#)

Overview of the BlackDiamond 12800 Series Switches

The BlackDiamond switches are chassis-based, Ethernet service core switches designed for core applications. For more information about configuring a BlackDiamond switch, see the *ExtremeXOS 12.0 Concepts Guide* and the *ExtremeXOS 12.0 Command Reference Guide*.

The features of these switches include:

- I/O modules that are hot-swappable and include Gigabit Ethernet copper ports (10/100/1000) and Gigabit Ethernet fiber ports (SFP), or 10 Gigabit Ethernet ports
- Management Switch Fabric Modules (MSMs) that provide the active switching fabric and CPU control subsystem
- Redundant, load-sharing, hot-swappable power supplies
- Field-replaceable, hot-swappable fan trays
- Auto-negotiation for half-duplex or full-duplex operation on 10/100/1000 Mbps ports
- Load sharing on multiple ports

The BlackDiamond 12800 series switches include two chassis models:

- BlackDiamond 12804 switch chassis (see [page 16](#))
- BlackDiamond 12802 chassis (see [page 18](#))

Full-Duplex Support

Extreme Networks switches provide full-duplex support for all ports. Full-duplex support means that frames can be transmitted and received simultaneously, which, in effect, doubles the bandwidth available on a link. Most ports on an Extreme Networks switch will auto-negotiate duplex in the default configuration. Gigabit Ethernet fiber ports and 10 Gigabit Ethernet ports operate only in full-duplex mode in accordance with technical standards.

Management Ports

Each BlackDiamond series Management Switch Fabric Module (MSM) has a 10/100BASE-TX Ethernet management port. This port allows you to communicate directly with the central processing unit (CPU) of the switch. You can plug an Ethernet cable directly from your laptop into the management port, for direct access into the switch. This access allows you to view and locally manage the switch configurations.

External Compact Flash Memory Card

All MSMs in the BlackDiamond family include a compact flash slot next to the console port on the MSM. This slot accepts a compact flash memory card, which can be used to download a new version of ExtremeXOS and for other functions, including capturing debug information and core dump files. See the *ExtremeXOS 12.0 Concepts Guide* for more information regarding the use of the external compact flash memory card.

The external compact flash slot supports third party compact flash cards.



NOTE

You must use an industrial-grade compact flash card in the external compact flash slot of the MSM.

BlackDiamond 12804 Switch Chassis

The BlackDiamond 12804 chassis consists of the following components:

- One 6-slot chassis with backplane
- Four dedicated I/O module slots, labeled 1, 2, 5, and 6
- Two MSM slots, labeled 3/A and 4/B
- Up to six SSI redundant AC/DC power supplies, accessed from the front of the unit
- One fan tray, accessed from the front right of the unit
- One connector for an ESD-preventive wrist strap
- Two PSU/fan controllers that collect and report data from the installed power supply units and the BlackDiamond fan tray. The PSU/fan controllers intervene in the event of power inconsistencies and provide primary/backup redundancy if a BlackDiamond 12804 PSU/fan controller fails.

Figure 1 shows a BlackDiamond 12804 chassis equipped with one MSM and three optional I/O modules.

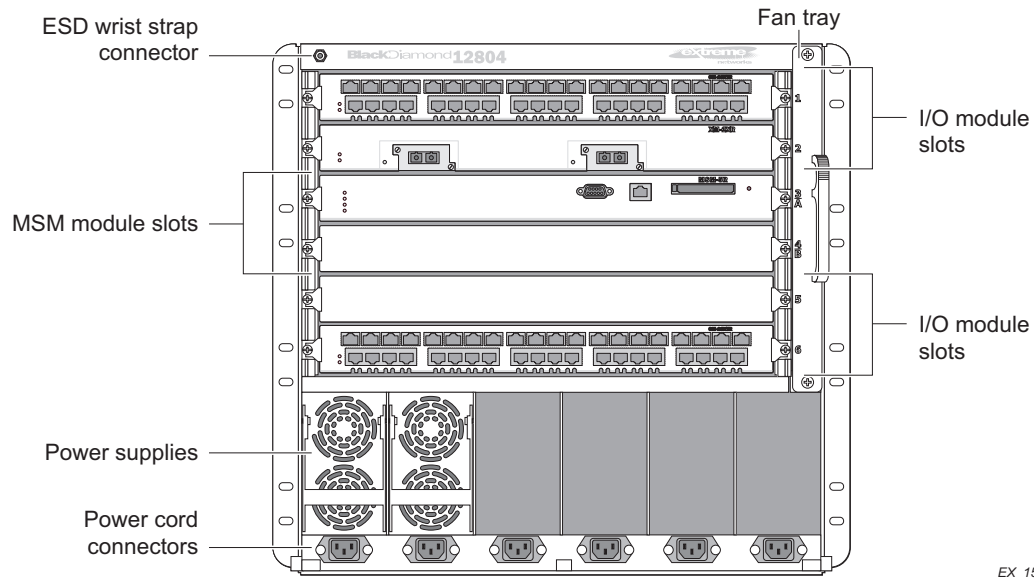
Figure 1: Front of the BlackDiamond 12804 Chassis

EX_157

Figure 2 shows the rear view of the BlackDiamond 12804 chassis.

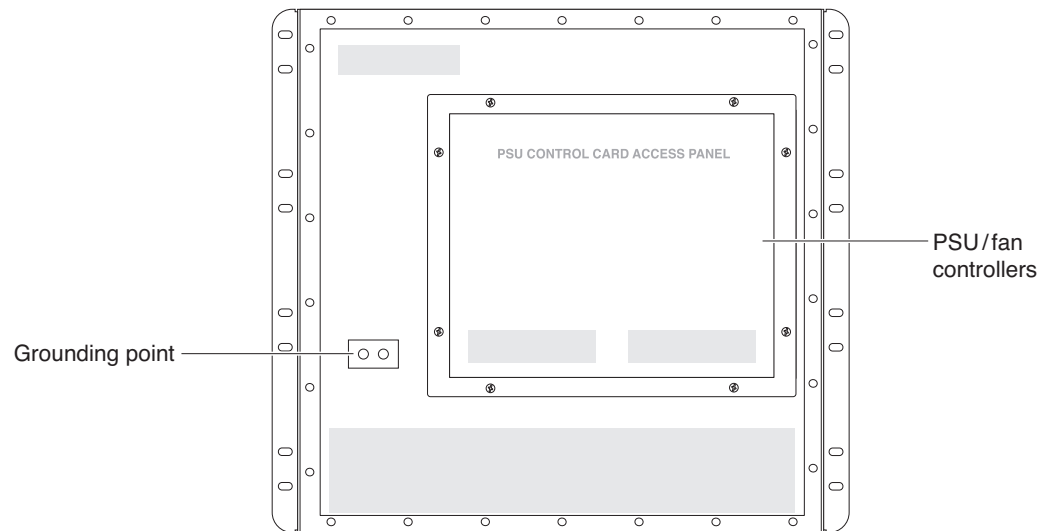
Figure 2: Rear Panel of the BlackDiamond 12804 Chassis

EX_128A

The rear panel of the BlackDiamond 12804 chassis provides:

- Chassis serial number
- Ethernet MAC address of the switch
- Symbols of safety certification
- Access to the PSU/fan controllers
- Attachment point for optional chassis ground

BlackDiamond 12802 Switch Chassis

The BlackDiamond 12802 chassis consists of the following components:

- One 3-slot chassis with backplane
- Two dedicated I/O module slots, labeled 1 and 2
- One MSM slot, labeled MSM
- Up to three redundant AC or DC power supplies, accessed from the back of the unit
- One fan tray, accessed from the back left of the unit
- One connector for an ESD-preventive wrist strap
- One PSU/fan controller that collects and reports data from the power supply units and the fan tray.

Figure 3 shows a BlackDiamond 12802 chassis equipped with one MSM and two I/O modules.

Figure 3: Front of the BlackDiamond 12802 Chassis

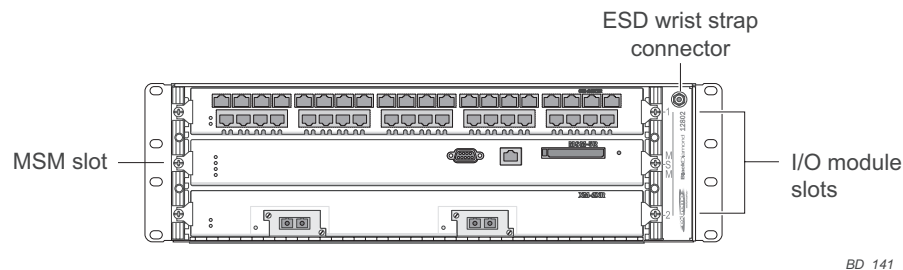
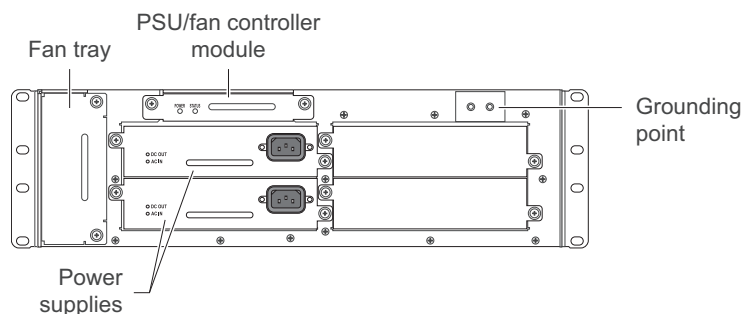

Figure 4 shows the rear panel of the BlackDiamond 12802 chassis.

Figure 4: Rear Panel of the BlackDiamond 12802 Chassis



The rear panel of the BlackDiamond 12802 chassis provides:

- Access to the fan tray
- Access to the PSU/fan controller module
- Four bays for installing power supplies
- Attachment point for optional chassis ground

The bottom of the chassis has a label showing safety certification symbols and the Ethernet MAC address of the switch. The chassis serial number is on the side near the back of the chassis.

This chapter includes the following sections:

- [Overview of the BlackDiamond 12800 Series Modules on page 19](#)
- [BlackDiamond 12800 Series MSMs on page 20](#)
- [BlackDiamond 12800 Series I/O Modules on page 23](#)

For information about installing modules in a BlackDiamond 12800 series switch, see [Chapter 4, “Installing Modules and Connecting Cables.”](#)

Overview of the BlackDiamond 12800 Series Modules

Two sets of modules are available for the BlackDiamond 12800 series switch: the 12800 series of modules and the 12800 R series of modules. All BlackDiamond 12800 series I/O modules and management system modules (MSMs) use the Extreme Networks 4th Generation ASICs that enable high availability, advanced security, and deterministic performance independent of traffic mix. The BlackDiamond 12800 series R-series modules further provide hierarchical QoS and larger MAC address, IP route, and ACL capacity for network designs that need the advanced QoS features and scale. The R-series modules support rate limiting, which is the ability to control bandwidth throughout the network. For complete details about rate limiting, refer to the *ExtremeXOS 12.0 Concepts Guide*. [Table 3](#) lists the modules available in each series.

Table 3: Modules for the BlackDiamond 12800 Series Switches

Module Type	BlackDiamond 12800 Series	BlackDiamond 12800 R Series
MSM	MSM-5 module	MSM-5R module MSM-6R module
I/O module	XM-2X I/O module GM-20XT I/O module GM-20T I/O module	XM-2XR I/O module GM-20XTR I/O module XM-2HR I/O module



CAUTION

Do not attempt to mix modules across Extreme Networks product lines. BlackDiamond 12800 series modules are for use only in a BlackDiamond 12802 or 12804 switch. When a BlackDiamond 12800 series switch is in use, ExtremeXOS software will not recognize a module from a different product line.



NOTE

The BlackDiamond R-series modules must be used together to take advantage of the higher feature set and scale. The ExtremeXOS software recognizes the MSM type installed in your BlackDiamond 12800 series switch and only allows use of compatible I/O modules from the same series. An error message is displayed if you attempt to mix modules.

BlackDiamond 12800 Series MSMs

The BlackDiamond 12800 series MSMs are the MSM-5 module, MSM-5R module, and MSM-6R module. These MSMs provide the active switching fabric and CPU control subsystem for the switch. The BlackDiamond 12802 chassis has one dedicated MSM slot; the BlackDiamond 12804 chassis has two dedicated MSM slots. One MSM is required for switch operation; however, adding a second MSM to a BlackDiamond 12804 chassis increases system availability through redundancy. Each MSM provides 192 Gbps of switching throughput through three ASICs. Each module also contains a temperature sensor, nonvolatile random-access memory (NVRAM), and a real-time clock.

The MSM-5 and the MSM-5R and MSM-6R modules support different sizes of Ternary Content Addressable Memory (TCAM). The MSM-5R and MSM-6R modules have more memory available for routing tables, learned MAC addresses, and access control lists (ACLs). For specific details about memory allocation, refer to the data sheet for each module.



CAUTION

You must use compatible MSMs and I/O modules from a single BlackDiamond 12800 module series. Do not attempt to mix MSMs from the two different series. The ExtremeXOS software recognizes the MSM type installed in your BlackDiamond 12800 series switch and only allows use of a second MSM of the same type and compatible I/O modules from the same series. An error message is displayed if you attempt to mix module series.

Software Requirements

Table 4 lists the minimum software revision required for MSMs in the BlackDiamond 12800 series switches.

Table 4: Required Software for BlackDiamond 12800 Series MSMs

Switch Model	MSM Model	Required Software
BlackDiamond 12804	MSM-5, MSM-5R	ExtremeXOS 11.4.1 or later
	MSM-6R	ExtremeXOS 12.0.2 or later
BlackDiamond 12802	MSM-5, MSM-5R	ExtremeXOS 12.0.1 or later
	MSM-6R	ExtremeXOS 12.0.2 or later

Make sure your BlackDiamond switches are running the required software version to support the switch model and MSM type. The MSM-6R requires ExtremeXOS 12.0.2 or later. A BlackDiamond 12802 switch running software earlier than version 12.0.1 will not be fully operational.

To upgrade the software in your BlackDiamond 12802 switch, access the latest image at the Extreme Networks support website at <http://www.extremenetworks.com/services/services-hub.aspx>. Follow the upgrade instructions in the ExtremeXOS Release Notes.



NOTE

The MSM slot in the BlackDiamond 12802 switch is labeled MSM on the front panel. The ExtremeXOS software refers to this MSM as MSM-A in all related displays and command output.

Redundant MSM Activity (BlackDiamond 12804 Switch)

The BlackDiamond 12804 switch can operate with a single MSM installed, providing full bandwidth with this single MSM. When you install a second MSM, one of the MSMs operates as the primary, and the other becomes the secondary or backup.

The primary MSM is responsible for upper-layer protocol processing and system management functions. The MSMs in the BlackDiamond 12804 switch are not load sharing. MSM(A) or MSM(B) handles packets while the other MSM is idle.

When you save the switch configuration, it is saved to all MSMs.

Selection of the primary MSM occurs automatically. The following examples describe the selection process:

- When a BlackDiamond 12804 switch boots with two MSMs installed, the MSM in slot 3/A becomes the primary.

If a switch is operating with one MSM and a second MSM is added to the switch after it has been powered up, the added MSM becomes the secondary. MSMs that operate as secondary, or backup, MSMs can be inserted and removed without disrupting network services.

- If you remove the primary MSM while the switch is operating, the secondary MSM performs a soft reset and then becomes the primary MSM.

For example, if you have a BlackDiamond 12804 switch with a primary MSM in slot 3/A and a secondary MSM in slot 4/B, and you remove the primary MSM from slot 3/A, the secondary, or backup, MSM in slot 4/B becomes the primary.

MSM LEDs

Table 5 describes the LED activity on the BlackDiamond 12800 series MSMs.

Table 5: BlackDiamond 12800 Series MSM LEDs

LED	Color	Meaning
SYS	Green blinking	Normal operation.
	Amber blinking	Diagnostic tests are running on the module. The LED resets if the diagnostics are terminated. The LED returns to blinking amber if another diagnostic test is started.
	Amber steady	Diagnostic failure has occurred.
	Off	Switch is not receiving power.
MSTR	Green steady	Module is operating as primary MSM.
	Amber	Module is operating as secondary, or backup, MSM.
	Green blinking	Power-on self-test (POST) is running.
	Off	Normal operation for diagnostics.
ERR	Amber	A critical software error has been logged since power-up.
	Off	Normal operation.
ENV	Green	Environment (temperature, fan, power supply) is operating properly.
	Amber	Environmental failure has occurred.

Features of the BlackDiamond 12800 MSMs

Figure 5 shows the MSM-5 module, Figure 6 shows the MSM-5R module, and Figure 7 shows the MSM-6R module.

Figure 5: MSM-5 Module

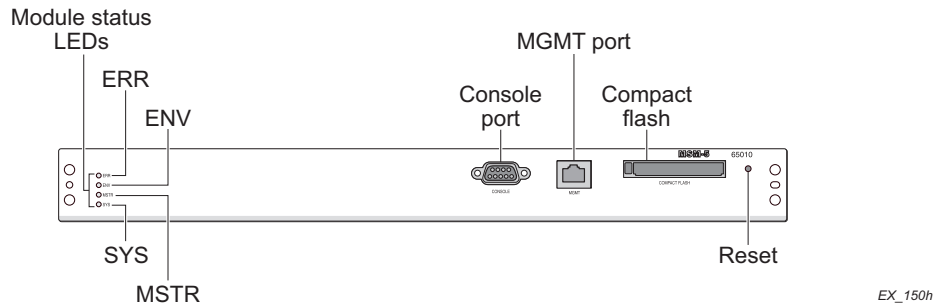

EX_150h

Figure 6: .MSM-5R Module

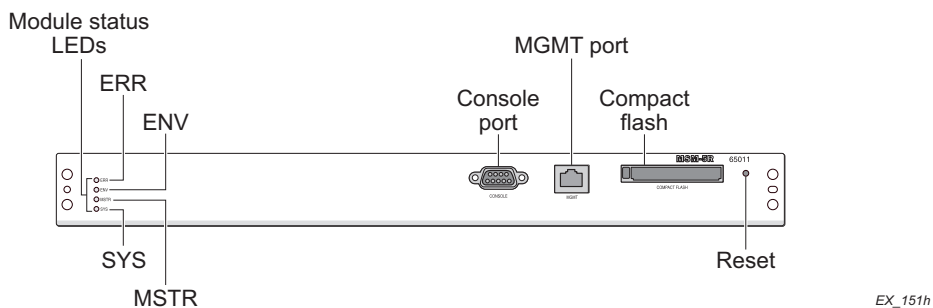

EX_151h

Figure 7: .MSM-6R Module

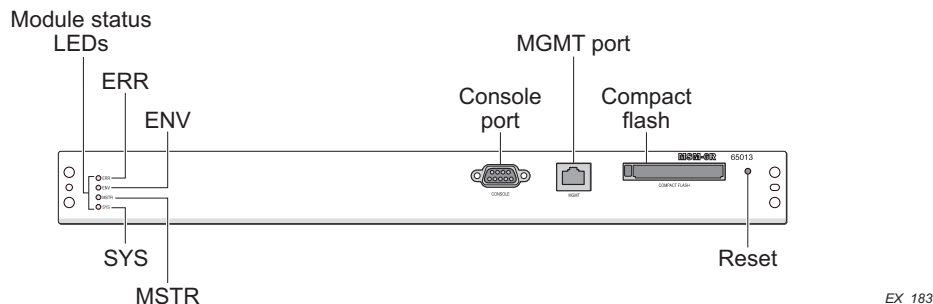

EX_183

Each MSM consists of a printed circuit board mounted on a metal panel that acts as the insertion vehicle in the BlackDiamond 12800 series switch. The module carrier also includes ejector/injector levers and captive retaining screws at each end of the module front panel.

The MSMs have the following features on the front panel:

- Console port—The DB-9 serial console port is used to connect a terminal, allowing you to perform local management.
- Management port—The 10/100 Mbps Ethernet management port allows you to connect an Ethernet cable directly from your laptop to the management port to view and locally manage the switch

configurations. This port can also be used to connect the system to a parallel management network for administration.

- Compact flash—You can insert an external compact flash memory card into this slot. (See [Chapter 2](#) for more information about Extreme Networks-supported compact flash cards.)
- Reset button—Use the Reset button to reset the MSM without removing the module from the chassis.



NOTE

Although the BlackDiamond 12800 series MSMs are similar in appearance, each MSM model has specific features. The MSM-5R and MSM-6R modules belong to the R series and include the rate limiting feature, which the MSM-5 module does not support.

To use rate limiting, you must install modules with model numbers ending in R. These include the MSM-5R module or MSM-6R module and the GM-20XTR I/O module, the XM-2XR I/O module, and the XM-2HR module.

The MSM-6R module provides the same functionality as the MSM-5R module, with higher performance for CPU-based activities such as BGP, OSPF, and MPLS.

BlackDiamond 12800 Series I/O Modules

No configuration information is stored on the I/O modules; all configuration information is stored on the MSMs.

When a BlackDiamond 12800 series switch is powered on, the software generates a default configuration for any slots that contain I/O modules. The default configuration allows the I/O module ports to participate in the VLAN named *default*. The default configuration for the I/O module is not preserved unless you explicitly save the configuration to NVRAM.

You can configure parameters of an I/O module after it is installed, or preconfigure a slot for a certain type of module and configuration. The preconfigured information is applied to the module after it is inserted. If you preconfigure a slot for a specific module type and then insert a different type of module, the module reverts to its default configuration.



NOTE

See the ExtremeXOS 12.0 Concepts Guide and the ExtremeXOS 12.0 Command Reference Guide for more information about configuring the modules.

I/O Module LEDs

Table 6 describes the LED activity for the BlackDiamond 12800 series I/O modules.

Table 6: BlackDiamond 12800 Series Switch I/O Module LEDs

LED	Color	Meaning
Status	Green blinking	Normal operation
	Amber blinking	Configuration error, hardware failure, diagnostic failure, or other severe module error
	Off	No power
DIAG	Off	Normal operation
	Amber blinking	Diagnostics in progress
	Amber	Diagnostic failure

Port LEDs on I/O Modules

Table 7 describes the LED activity for each port on the GM-20XT, GM-20XTR, XM-2X, XM-2XR, and XM-2HR I/O modules.

Table 7: Port LEDs for the BlackDiamond GM-20XT, GM-20XTR, XM-2X, XM-2XR, and XM-2HR I/O Modules

LED	Color	Meaning
Port	Solid green	Link up
	Slow green blinking	Port disabled
	Amber blinking	Activity
	Off	Link down

Table 8 describes the LED activity for each port on the BlackDiamond GM-20T I/O module.

Table 8: Port LEDs for the BlackDiamond GM-20T Module

LED	Color	Meaning
Port with power enabled	Solid amber	Link up
	Slow amber blinking	Port disabled
	Amber blinking	Activity
	Slow amber blinking	Link down
	Blinking amber/green	Power fault or insufficient power
Port with power disabled	Solid green	Link up
	Slow green blinking	Port disabled
	Green blinking	Activity
	Off	Link down
	Blinking amber/green	Power fault or insufficient power

GM-20T I/O Module

Figure 8 shows the GM-20T I/O module.

Figure 8: GM-20T I/O Module

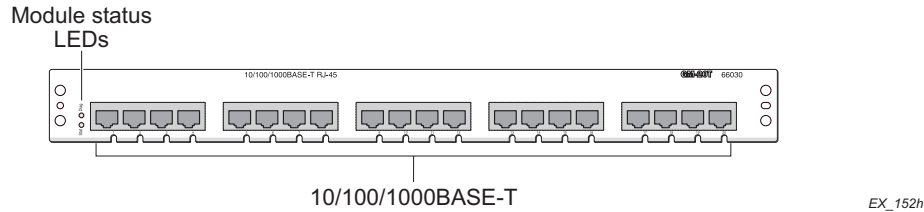

The GM-20T I/O module has 20 autosensing 10/100/1000BASE-T ports that use standard RJ-45 connectors.

The default configuration of the GM-20T I/O module is as follows. All ports:

- Are added to the default VLAN as untagged.
- Inherit the properties of the default VLAN (for example, protocol type and VLANid).
- Operate in autonegotiation mode.

GM-20T LEDs

The GM-20T I/O module has the following LEDs:

- Module status
- Module diagnostics
- Port status
- Power status

GM-20XT and GM-20XTR I/O Modules

Figure 9 shows the GM-20XT I/O module, and Figure 10 shows the GM-20XTR I/O module.

Figure 9: GM-20XT I/O Module

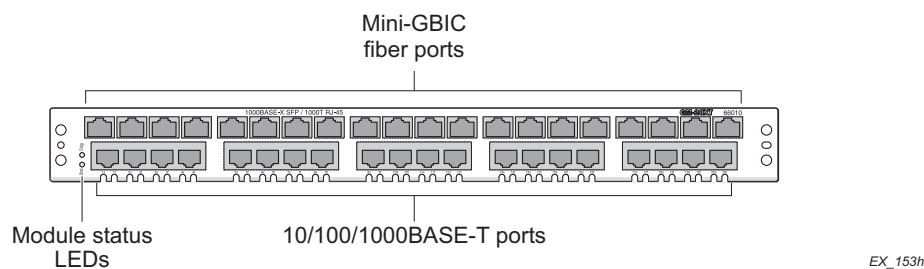
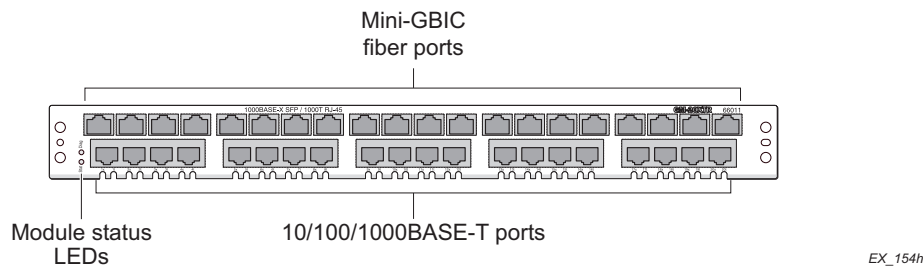

Figure 10: GM-20XTR I/O Module**NOTE**

Although the GM-20XT module and the GM-20XTR module are similar in appearance, they have different functionality. The GM-20XTR is part of the R series and includes the rate limiting feature; the GM-20XT module does not support rate limiting.

To use rate limiting, you must install the MSM-5R plus the GM-20XTR I/O module and/or the XM-2XR I/O module.

The GM-20XT module and GM-20XTR I/O module have 20 autosensing 10/100/1000BASE-T ports that use standard RJ-45 connectors and 20 SFP ports. Each pair of ports operates as a combination port. Either the copper port or the fiber port can be active, but not both. You can set up a redundant link by connecting both the copper and fiber ports in the pair. The port that is connected first becomes the active port. If that port fails, the second port automatically becomes active. For more information about redundant ports and automatic failover, see the *ExtremeXOS Concepts Guide*.

The default configuration of the GM-20XT and GM-20XTR I/O module is as follows. All ports:

- Are added to the default VLAN as untagged.
- Inherit the properties of the default VLAN (for example, protocol type and VLANid).
- Operate in autonegotiation mode.

GM-20XT and GM-20XTR LEDs

The GM-20XT and GM-20XTR I/O modules have the following LEDs:

- Module status
- Module diagnostics
- Port status

XM-2X and XM-2XR I/O Modules

Figure 11 shows the XM-2X I/O module, and Figure 12 shows the XM-2XR I/O module.

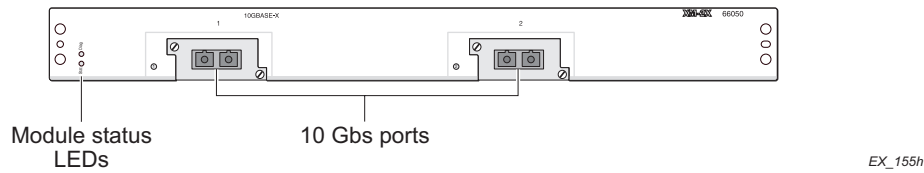
Figure 11: XM-2X I/O Module

EX_155h

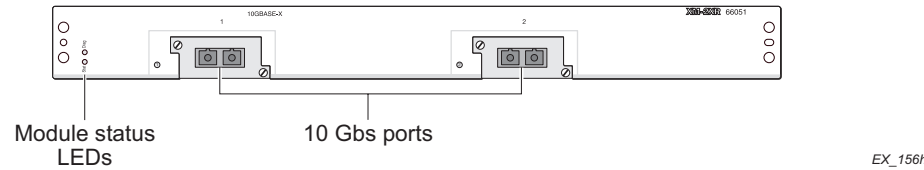
Figure 12: XM-2XR I/O module

EX_156h

**NOTE**

Although the XM-2X module and the XM-2XR module are similar in appearance, the functionality of each I/O module varies. The XM-2XR module is part of the R series and includes the rate limiting feature; the XM-2X module does not support rate limiting.

To use rate limiting, you must install the MSM-5R plus the GM-20XTR I/O module and/or the XM-2XR I/O module.

The XM-2X module and XM-2XR module have two unpopulated XENPAK-based 10 Gigabit Ethernet ports.

The default configuration of the XM-2X and XM-2XR I/O modules is as follows. All ports:

- Are added to the default VLAN as untagged.
- Inherit the properties of the default VLAN (for example, protocol type and VLANid).

XM-2X and XM-2XR LEDs

The XM-2X module and XM-2XR module have the following LEDs:

- Module status
- Module diagnostics
- Port status

XM-2HR I/O Module

Figure 13 shows the XM-2HR I/O module.

Figure 13: XM-2HR I/O Module

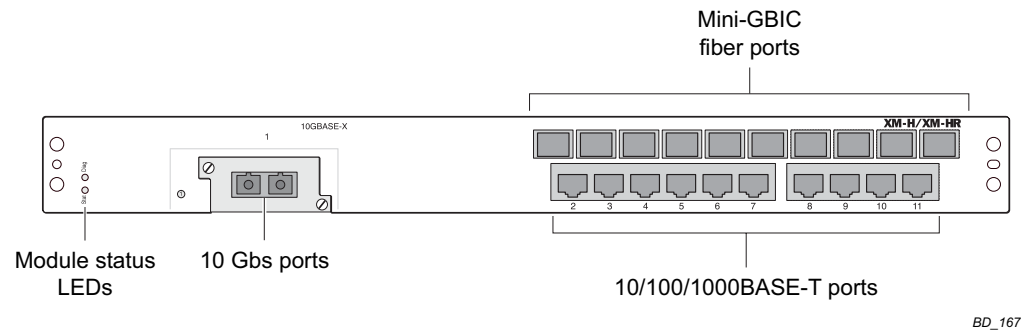

The XM-2HR I/O module has 10 SFP ports and 10 autosensing 10/100/1000BASE-T ports that use standard RJ-45 connectors. In addition, it has one unpopulated XENPAK-based 10-Gigabit Ethernet port.

The default configuration of the XM-2HR I/O module is as follows. All ports:

- Are added to the default VLAN as untagged.
- Inherit the properties of the default VLAN (for example, protocol type and VLANid).

In addition, the 10/100/1000BASE-T ports and SFP ports operate in autonegotiation mode.

XM-2HR LEDs

The XM-2HR I/O module has the following LEDs:

- Module status
- Module diagnostics
- Port status

3 Extreme Networks Power Supply Units for BlackDiamond Switches

This chapter includes the following sections:

- Overview of BlackDiamond 12800 Series Power Supplies on page 29
- Extreme Networks 1200 W DC PSU on page 30
- Extreme Networks 700/1200 W AC PSU on page 32
- Extreme Networks 325 W DC Power Supply on page 34
- Extreme Networks 325 W AC Power Supply on page 36



NOTE

For central DC power connections, the 1200 W DC PSU and 325 W DC PSU are intended to be installed only in restricted access locations (dedicated equipment rooms, equipment closets, or the like) in accordance with Articles 110-16, 110-17, and 110-18 of the National Electric Code, ANSI/NFPA-70. All wiring methods involving the DC input cable assembly must be performed according to the relevant articles of the National Electrical Code.



WARNING!

Field operators must not attempt to open the PSU enclosure for any reason; the PSU does not contain user-serviceable parts. In the event of failure, return the defective PSU to Extreme Networks for repair or replacement.

Overview of BlackDiamond 12800 Series Power Supplies

The BlackDiamond 12800 series switches can be powered by either AC or DC power supplies (PSUs). Power supplies in the BlackDiamond 12800 series switches are fully fault tolerant and load-sharing in an N+1 configuration. After the system is properly configured, if one PSU fails, the others will provide sufficient power to operate a fully loaded switch.

The BlackDiamond power supply units are intended for use in specific BlackDiamond switches only. [Table 9](#) lists the power supplies for use in the BlackDiamond 12800 series switches.

Table 9: PSUs for the BlackDiamond 12800 Series Switches

BlackDiamond Switch	Compatible PSU	Compatibility Notes
BlackDiamond 12804	700W/ 1200W AC PSU OR 1200W DC PSU	Extreme Networks does not recommended using the 700/1200 W AC PSU in combination with a 1200W DC PSU.
BlackDiamond 12802	325 W AC PSU, Model # 65021 OR 325 W DC PSU, Model # 65022	Extreme Networks does not recommended using the 325 W AC PSU in combination with the 325 W DC PSU.

Extreme Networks 1200 W DC PSU

Figure 14 shows the Extreme Networks 1200 W DC UL-listed accessory power supply unit (Model 60021/PS 2350). This power supply is compatible with the BlackDiamond 12804 switch. The power supply bay in the BlackDiamond 12804 switch can accommodate up to six hot-swappable Extreme Networks 1200 W DC PSUs. You cannot install a 1200 W DC PSU in the BlackDiamond 12802 switch.

Figure 14: 1200 W DC PSU

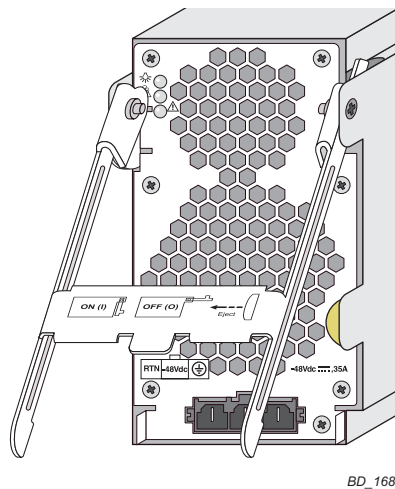

In an N+N configuration, each group of power supplies can provide A/B feed redundancy for the system.

The input DC cable has an input connector on one end and precut wire on the other end that goes to the DC power source (see Figure 15). The connector end has a locking mechanism that locks onto the DC PSU to prevent accidental removal of the input DC cable.

Figure 15: Input DC Power Cable for the 1200 W DC PSU

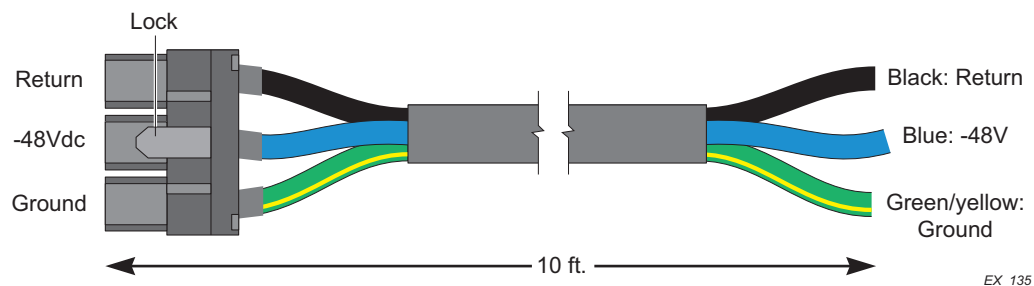

Airflow enters from the front vents on the 1200 W DC PSU and exits to the rear vents of the switch. Airflow through the 1200 W DC PSU is independent of the airflow through the rest of the switch.

To use the 1200 W DC PSU, you need a -48 V DC power source capable of providing 50 A dedicated power to each of the 1200 W DC PSUs installed in the switch.

**NOTE**

Extreme Networks does not recommend installing the 1200 W DC PSU with any AC PSU in the same BlackDiamond 12804 system. Extreme Networks recommends that DC and AC PSU units not be used together in the same BlackDiamond switch.

For central DC power connections, the 1200 W DC PSU is intended to be installed only in restricted access locations (dedicated equipment rooms, equipment closets, or the like) in accordance with Articles 110-16, 110-17, and 110-18 of the National Electric Code, ANSI/NFPA-70.

**WARNING!**

Field operators must not attempt to open the 1200 W DC PSU enclosure for any reason; the PSU does not contain user-serviceable parts. In the event of failure, return the defective 1200 W DC PSU to Extreme Networks for repair or replacement.



Minimum Software Required

You must be running ExtremeWare XOS version 11.3 or later for the system to recognize the DC PSU.

LEDs

The front panel of the 1200 W DC PSU provides status LEDs. [Table 10](#) identifies the symbols and describes the LED activity.

Table 10: LEDs on the 1200 W DC PSU

PSU Condition	 Power Green	 Predictive Fail Amber	 Fail Amber
Power supply DC outputs working normally	On	Off	Off
DC input power present/standby output on	Blinking	Off	Off
Current limit on 48 VDC output	On	Off	Blinking
Predictive failure	On	Blinking	Off
No input power to this PSU only	Off	Off	On
No input power to any PSU	Off	Off	Off
Power supply failure	Off	Off	On

Extreme Networks 700/1200 W AC PSU

Figure 16 shows the Extreme Networks 700/1200 W AC UL-listed accessory power supply unit (Model 60020/PS 2336). This power supply is compatible with the BlackDiamond 12804 switch. The power supply bay in the BlackDiamond 12804 switch can accommodate up to six hot-swappable Extreme Networks 700/1200 W AC PSUs.



Field operators must not attempt to open the 700/1200 W AC PSU enclosure for any reason; the PSU does not contain user-serviceable parts. In the event of failure, return the defective 700/1200 W AC PSU to Extreme Networks for repair or replacement.

Figure 16: Extreme Networks 700/1200 W AC PSU

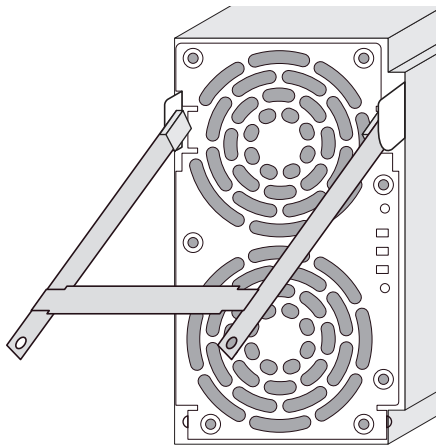

EX_015



Airflow enters from the front vents on the Extreme Networks 700/1200 W AC PSU and exits to the rear vents of the switch. Airflow through the Extreme Networks 700/1200 W AC PSU AC is independent from the airflow through the rest of the switch.

The AC input is located on the switch chassis directly in back of each power supply bay. The front of the Extreme Networks 700/1200 W AC PSU has a handle with a lever mechanism for both insertion and removal as shown in Figure 16.

LEDs

The front panel of the 700/1200 W AC PSU provides status LEDs. [Table 11](#) describes the LED activity.

Table 11: LEDs on the 700/1200 W AC PSU

PSU Condition	 Power Green	 Predictive Fail Amber	 Fail Amber
Power supply AC outputs working normally	On	Off	Off
AC input power present/standby output on	Blinking	Off	Off
Current limit on 48 VDC output	On	Off	Blinking
Predictive failure	On	Blinking	Off
No input power to this PSU only	Off	Off	On
No input power to any PSU	Off	Off	Off
Power supply failure	Off	Off	On

Power Supply Cords

Extreme Networks 700/1200 W AC PSU(s) are shipped with both 110 V AC and 220 V AC power supply cords. The 110 V AC power supply cord allows for a maximum DC output power of 700 W. The 220V AC power supply cord allows for a maximum DC output power of 1200 W.

All power supply cords provided by Extreme Networks are designed for use in North America only. Power supply cords for use outside of North America are typically provided by a third-party distribution center and must meet the following requirements:

- Power supply cords must be agency certified for country of use.
- Power supply cords must contain an IEC 320 C13 connector on the end of the PSU.
- Power supply cords must contain an appropriately rated and approved wall plug applicable to the country of installation.
- Power supply cords must be less than 5 m long.
- Wire size must be a minimum of 16 AWG (1.0 mm²) copper-stranded.



WARNING!

Always be sure that the source outlet is properly grounded before plugging the AC power cord into the Extreme Networks 700/1200 W AC PSU.

Fuse

The Extreme Networks 700/1200 W AC PSU line and neutral legs are both fused. Power to the switch may still be live if the neutral fuse is open. This is not a field operator replaceable fuse. In the event of failure, immediately return the Extreme Networks 700/1200 W AC PSU for a complete replacement.



WARNING!

Field operators must not attempt to configure or replace fuses in Extreme Networks 700/1200 W AC PSUs. In the event of failure, immediately return the defective 700/1200 W AC PSU for a complete replacement.

Specifications

The 700/1200 W AC PSU functions from 90 V to 264 V and 47 Hz to 63 Hz AC Input. Each PSU provides 700 W to the system if the AC input is in the 110 V low-line output power range and 1200 W to the system if the AC input is in the 220 V high-line output power range.

A greater number of PSUs are needed to support the load if the low-line power range is used to power the switch. The software determines the maximum available power required for the switch and enables the modules accordingly.



CAUTION

The 700/1200 W AC PSU does not have a switch for turning the unit on and off. Remove the plug from the electrical outlet to disconnect power to the 700/1200 W AC PSU. Make sure that this connection is easily accessible.

Make sure that the 700/1200 W AC PSU circuit is not overloaded. Use proper over-current protection, such as a circuit-breaker, to prevent over-current conditions.

Extreme Networks 325 W DC Power Supply

Figure 17 shows the Extreme Networks® 325 W DC UL-listed accessory power supply unit (PSU), Model 65022. This power supply is compatible with the BlackDiamond 12802 switch. Up to three 325 W DC PSUs can be installed in the BlackDiamond 12802 switch.



NOTE

A minimum of two Extreme Networks 325 W DC PSUs are required to run a BlackDiamond 12802 switch.

Figure 17: Extreme Networks 325 W DC PSU

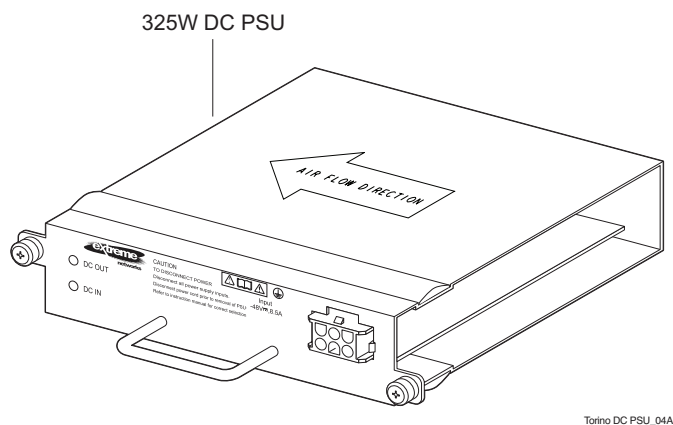

NOTE

For centralized DC power connection, this product is intended to be installed in restricted access locations (dedicated equipment rooms, equipment closets, or the like) in accordance with Articles 110-16, 110-17, and 110-18 of the National Electric Code, ANSI/NFPA 70.



NOTE

The Extreme Networks 325 W DC PSU cannot be used in combination with any other Extreme Networks PSU.

The Extreme Networks 325 W DC PSU requires input DC cable Model 65025 (see Figure 18). The input DC cable has an input connector on one end and precut wire on the other end that goes to the DC power source. The connector end has a locking mechanism that locks onto the DC PSU to prevent accidental removal of the input DC cable.

This cable is shipped separately from the power supply unit. You *must* use this cable with the Extreme Networks 325 W DC PSU.

Figure 18: Input DC Cable for the Extreme Networks 325 W DC PSU

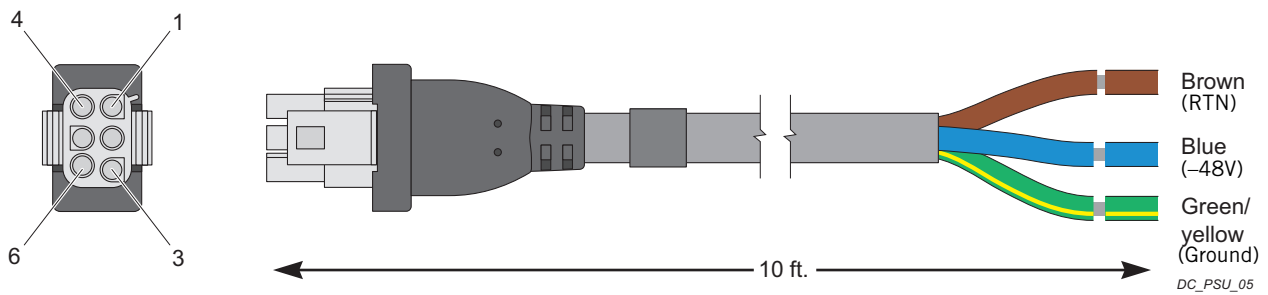

Each Extreme Networks 325 W DC PSU must be powered by a 15 A dedicated power source that delivers -40 to -72 VDC constant power to each 325 W DC PSU. Power distribution to the 325 W DC PSU shall be provided using the Model # 65025 -48 V DC cable. Power to the 325 W DC PSU can be from either a 15 A UL-approved overcurrent protection breaker or an SELV-approved power source in accordance with IEC 60950-1 utilizing 15 A overcurrent protection.

Minimum Software Required

You must be running ExtremeWare XOS version 12.0 or later for the system to recognize the DC PSU.

LEDs

The front panel of the Extreme Networks 325 W DC PSU provides status LEDs. Table 12 describes the meanings of these LEDs.

Table 12: LEDs on the 325 W DC PSU

PSU Condition	DC In LED Status	DC Out LED Status
No DC input power	Off	Off
No DC input power (receiving standby power from the chassis)	Amber	Off
DC input good (main outputs disabled)	Green	Off
DC input good, output fault	Green	Amber
DC input good, DC output good	Green	Green

Fuse

The Extreme Networks 325 W DC PSU line is fused. This fuse is not replaceable in the field. In the event of failure, immediately return the Extreme Networks 325 W DC PSU for a complete replacement.



WARNING!

Field operators must not attempt to configure or replace fuses inside Extreme Networks 325 W DC PSUs! In the event of failure, immediately return the defective Extreme Networks 325 W DC PSU for a complete replacement.

Specifications

The 325 W DC PSU functions from 40 V to -72 V DC input. The software determines the maximum available power required for the switch and enables the modules accordingly.



CAUTION

The 325 W DC PSU does not have a switch for turning the unit on and off. Remove DC power by de-energizing the DC power circuit.



CAUTION

Make sure that the 325 W DC PSU circuit is not overloaded. Use proper over-current protection, such as a circuit-breaker, to prevent over-current conditions.

Extreme Networks 325 W AC Power Supply

Figure 19 shows the Extreme Networks 325 W AC UL-listed accessory power supply unit, Model 65021. This power supply is compatible with the BlackDiamond 12802 switch.

Figure 19: Extreme Networks 325 W AC PSU

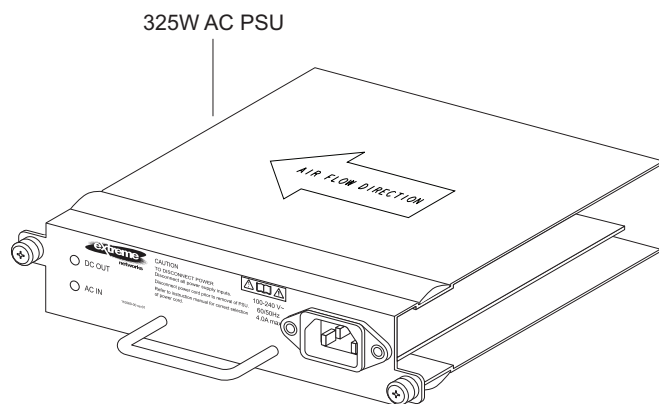

The power supply bay can accommodate up to three hot-swappable Extreme Networks 325 W AC PSUs. See the *ExtremeXOS 12.0 Concepts Guide* for information about configuring your Extreme Networks BlackDiamond switch.

**NOTE**

The Extreme Networks 325 W AC PSU cannot be used in combination with any other Extreme Networks PSU.

The 325 W AC PSU functions from 90 V to 264 V and 47 Hz to 63 Hz AC Input. The software determines the maximum available power required for the switch and enables the modules accordingly.

LEDs

The front panel of the Extreme Networks 325 W AC PSU provides status LEDs. [Table 13](#) describes the meanings of these LEDs.

Table 13: LEDs on the 325 W AC PSU

PSU Condition	AC In LED Status	DC Out LED Status
No AC input power	Off	Off
No AC input power (receiving standby power from the chassis)	Amber	Off
AC input good (main outputs disabled)	Green	Off
AC input good, output fault	Green	Amber
AC input good, DC output good	Green	Green

Replacing AC Power Supply Cords

Each Extreme Networks 325 W AC PSU is shipped with a 110 V AC UL-listed power cord.

All power supply cords provided by Extreme Networks are designed for use in the United States and Canada only. Power supply cords for use outside of North America are typically provided by a third-party distribution center and must meet the following requirements:

- Power supply cords must be agency certified for country of use.
- Power supply cords must contain an IEC 320 C13 connector for insertion into the IEC 320 C14 receptacle on the PSU.
- Power supply cords must contain an appropriately rated and approved wall plug applicable to the country of installation.
- Power supply cords must be less than 5 m long.
- Wire size must be a minimum of 18 AWG (0.82 mm²) copper-stranded.

**WARNING!**

Make sure that the source outlet is properly grounded before plugging the AC power cord into the Extreme Networks 325 W AC PSU.

Fuse

The Extreme Networks 325 W AC PSU line is fused. This is not a field operator replaceable fuse. In the event of failure, immediately return the Extreme Networks 325 W AC PSU for a complete replacement.



WARNING!

Field operators must not attempt to configure or replace fuses in Extreme Networks 325 W AC PSUs! In the event of failure, immediately return the defective Extreme Networks 325 W AC PSU for a complete replacement.

2

Installing BlackDiamond Switches and Modules

4 Site Preparation

This chapter includes the following sections:

- [Planning Your Site on page 41](#)
- [Meeting Site Requirements on page 42](#)
- [Evaluating and Meeting Cable Requirements on page 48](#)
- [Meeting Power Requirements on page 53](#)
- [Applicable Industry Standards on page 55](#)

By carefully planning your site, you can maximize the performance of your existing network and ensure that it is ready to migrate to future networking technologies.

The information in this chapter is intended for the system administrator, network equipment technician, network manager, or facilities manager responsible for installing and managing the network hardware. The chapter assumes a working knowledge of local area network (LAN) operations, and a familiarity with communications protocols that are used on interconnected LANs.

Installation, maintenance, and removal of a switch, chassis, or its components must be done by qualified service personnel only. Qualified service personnel have had appropriate technical training and experience that is necessary to be aware of the hazards to which they are exposed when performing a task and of measures to minimize the danger to themselves or other people.



NOTE

Before installing or removing any components of the system, or before carrying out any maintenance procedures, you must read the safety information provided in [Appendix A](#) of this guide.

Planning Your Site

To install your equipment successfully, you should plan your site carefully. The site planning process has three major parts:

- Meeting site requirements
 - The physical installation site must meet the following requirements for a safe and successful installation:
 - Building and electrical code requirements
 - Environmental, safety, and thermal requirements for the equipment you plan to install
 - Equipment rack requirements

- Evaluating and meeting cable requirements

After examining your physical site and verifying that all environment requirements are met, evaluate and compare your existing cable plant with the requirements of the Extreme Networks equipment to determine if you need to install new cables.

- Meeting power requirements
 - To run your equipment safely, you must meet the specific power requirements for each power supply unit installed in the system. For power supply specifications, see “Power Supplies for the BlackDiamond 12800 Series Switches” on page 151.

Meeting Site Requirements

This section addresses the various requirements to consider when preparing your installation site, including:

- [Operating Environment Requirements](#)
- [Rack Specifications and Recommendations](#)

Operating Environment Requirements

Verify that your site meets all environmental and safety requirements.

Virtually all areas of the United States are regulated by building codes and standards. During the early planning stages of installing or modifying your LAN, it is important that you develop a thorough understanding of the regulations that pertain to your location and industry.

Building and Electrical Codes

Building and electrical codes vary depending on your location. Comply with all code specifications when planning your site and installing cable. The following sections are provided as a resource to obtain additional information.

Information about major building codes is located at the following websites:

- International Code Council (ICC); 5203 Leesburg Pike; Falls Church, Virginia 22041 USA.
<http://www.iccsafe.org>
<http://www.sbcci.org>

Five authorities on electrical codes are:

- National Electrical Code (NEC) Classification (USA only)—a recognized authority on safe electrical wiring. Federal, state, and local governments use NEC standards to establish their own laws, ordinances, and codes on wiring specifications. The NEC classification is published by the National Fire Protection Association (NFPA). The address is NFPA; 1 Batterymarch Park; Quincy, Massachusetts 02169 USA. <http://www.nfpa.org>
- Underwriters’ Laboratory (UL) (USA only)—an independent research and testing laboratory. UL evaluates the performance and capability of electrical wiring and equipment to determine whether they meet certain safety standards when properly used. Acceptance is usually indicated by the words “UL Approved” or “UL Listed.” The address is UL; 333 Pfingsten Road; Northbrook, Illinois 60062-2096 USA. <http://www.ul.com>
- National Electrical Manufacturing Association (NEMA) (USA only)—an organization of electrical product manufacturers. Members develop consensus standards for cables, wiring, and electrical components. The address is NEMA; 1300 N. 17th Street; Rosslyn, Virginia 22209. <http://www.nema.org>
- Electronics Industries Alliance (EIA)—a trade association that develops technical standards, disseminates marketing data, and maintains contact with government agencies in matters relating to

the electronics industry. The address is EIA; 2500 Wilson Boulevard; Arlington, Virginia 22201 USA. <http://www.eia.org>

- Federal Communications Commission (FCC) (USA only)—a commission that regulates all interstate and foreign electrical communication systems that originate in the United States according to the Communications Act of 1934. The FCC regulates all U.S. telephone and cable systems. The address is FCC; 445 12th Street S.W.; Washington, D.C. 20554 USA. <http://www.fcc.gov>

Wiring Closet Considerations

Be aware of the following recommendations for your wiring closet:

- Be sure that your system is easily accessible for installation and service. See “[Rack Specifications and Recommendations](#)” on page 46 for information.
- Use appropriate AC or DC power, power distribution, and grounding for your specific installation.
- Use a vinyl floor covering in your wiring closet. (Concrete floors accumulate dust, and carpets can cause static electricity.)
- Prevent unauthorized access to wiring closets by providing door locks. Install the equipment in a secured, enclosed, and restricted access location, ensuring that only qualified service personnel have access to the equipment.
- Provide adequate overhead lighting for easy maintenance.
- Be sure that each wiring closet has a suitable ground. All equipment racks and equipment installed in the closet should be grounded.
- Be sure that all system environmental requirements are met, such as ambient temperature and humidity.



NOTE

Extreme Networks recommends that you consult an electrical contractor for commercial building and wiring specifications.

Temperature

Extreme Networks equipment generates a significant amount of heat. It is essential that you provide a temperature-controlled environment for both performance and safety.

Install the equipment only in a temperature- and humidity-controlled indoor area that is free of airborne materials that can conduct electricity. Too much humidity can cause a fire. Too little humidity can produce electrical shock and fire.

Follow these general thermal recommendations for your wiring closet:

- Be sure that the ventilation in the wiring closet is adequate to maintain a temperature below 104° F (40° C).
- Install a reliable air conditioning and ventilation system.
- Keep the ventilation in the wiring closet running during non-business hours; otherwise, the equipment can overheat.
- Maintain an ambient operating temperature of 32° to 104° F (0° to 40° C).
- Maintain a storage temperature of -40° to 158° F (-40° to 70° C).

**NOTE**

Like all electrical equipment, product lifetimes degrade with increased temperature. If possible, temperatures should be kept at approximately 78° F (25° C) or lower.

Humidity

To maximize equipment life, keep operating humidity between 50% and 70% relative humidity (non-condensing) during typical operation. The equipment can operate between 10% and 95% relative humidity (non-condensing) for short intervals.

BlackDiamond Family Chassis Spacing Requirements

Because of chassis-to-chassis heating, Extreme Networks recommends placing no more than three chassis next to each other. In addition, Extreme Networks recommends the following general principles for equipment placement:

- Leave a minimum of one empty 19-inch rack between two sets of three adjacent BlackDiamond switches.
or
- Place patch panels between two sets of three adjacent BlackDiamond switches. A patch panel does not require any power and does not generate any heat.

**NOTE**

Up to five adjacent switches will continue to function without safety concerns. However, product lifetime may degrade with continued exposure to high temperatures in close proximity and long term reliability may be compromised.

Airflow Requirements

To ensure proper airflow through a BlackDiamond 12800 series switch, refer to the following recommendations:

- BlackDiamond 12800 series switches require a minimum of 1.5 inches (4 cm) around both the left and right sides of the chassis from any cabinet wall or other obstruction for proper airflow.
- Air temperature measured approximately 1 inch (2.5 cm) from the fan inlet should be less than 104 °F (40 °C).

In the BlackDiamond 12800 series switches, airflow through the power supplies is independent of the airflow through the modules as shown in [Figure 20](#).

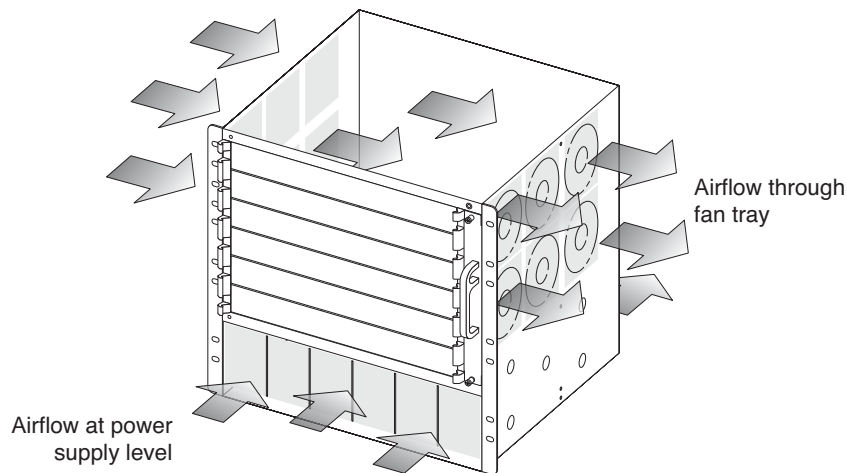
Figure 20: Airflow Through the BlackDiamond 12804 Chassis

ASP051

Electrostatic Discharge

Your system must be protected from static electricity or electrostatic discharge (ESD). Take the following measures to ensure optimum system performance:

- Remove materials that can cause electrostatic generation (such as synthetic resins) from the wiring closet. Check the appropriateness of floor mats and flooring.
- Connect metal chassis, conduit, and other metals to ground using dedicated grounding lines.
- Use electrostatically safe equipment and the ESD-preventive wrist strap that is provided with your equipment. All switches come with ESD-preventive wrist strap connectors and an ESD-preventive wrist strap as shown in [Figure 21](#).

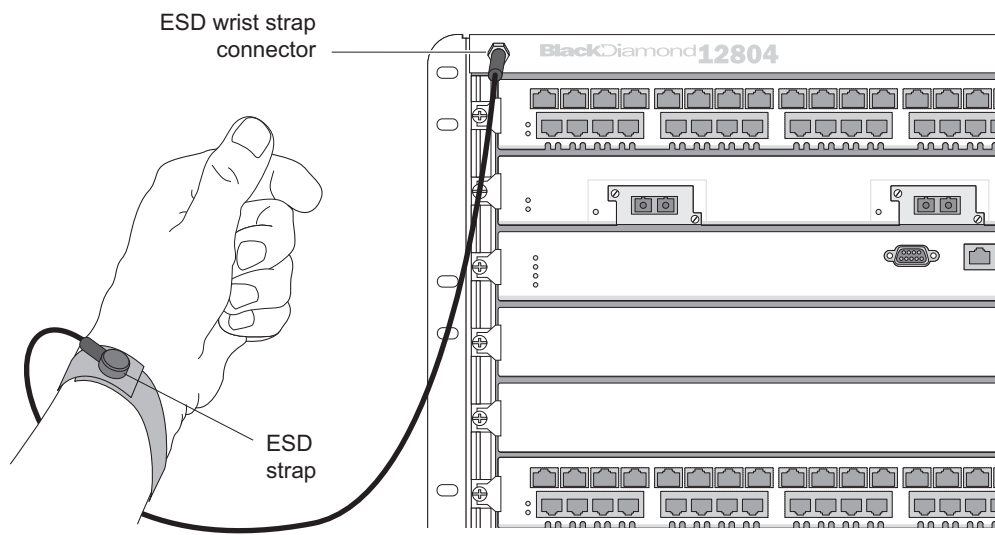
Figure 21: Using an ESD-Preventive Wrist Strap

BD_171

Rack Specifications and Recommendations

Racks should conform to conventional standards. In the United States, use EIA Standard RS-310C: Racks, Panels, and Associated Equipment. In countries other than the United States, use IEC Standard 297. In addition, verify that your rack meets the basic mechanical, space, and earthquake requirements that are described in this section.

Mechanical Recommendations for the Rack

Use equipment racks that meet the following mechanical recommendations:

- Use an open style, 19-inch rack to facilitate easy maintenance and to provide proper ventilation.
- Use a rack made of steel or aluminum.
- The rack should use the universal mounting rail hole pattern that is identified in IEC Standard 297.
- The rack should have designated earth grounding connections (typically on the base).
- The rack must meet earthquake safety requirements equal to that of the installed chassis.
- The mounting holes should be flush with the rails to accommodate the chassis.
- Install equipment into the lower half of the rack first to avoid making the rack top-heavy.
- The rack should support approximately 600 pounds (272 kilograms).

Protective Grounding for the Rack

Use a rack grounding kit and a ground conductor that is carried back to earth or to another suitable building ground.

All Extreme Networks switches are designed with mounting brackets that provide solid metal-to-metal connection to the rack. If you do not use equipment racks, you can attach wiring terminals directly to the mounting brackets for appropriate grounding. Extreme Networks switches have grounding terminals that are mounted on the back of the chassis.

At a minimum, follow these guidelines to ground equipment racks to the earth ground:

- CAD weld appropriate wire terminals to building I-beams or earth ground rods.
- Use the appropriate chassis grounding wire for your system, which is dependent upon the available input current to the power supply.
 - For AC systems using a 20A breaker per PSU (SSI AC), the chassis ground can be as small as 14 AWG. The power cable ground should be the same size as the primary.
 - For DC systems using a 40A breaker per PSU (SSI DC), the chassis ground can be as small as 10 AWG. The power cable ground should be the same size as the primary.



NOTE

For complete details on power supplies and power supply cords, refer to the following: [Chapter 4, "Extreme Networks Power Supply Units for BlackDiamond Switches,"](#) and ["Selecting Power Supply Cords" on page 136 in Appendix A, "Safety Information."](#) Drill and tap wire terminals to equipment racks.

- Position the earth ground as close to the equipment rack as possible to maintain the shortest wiring distance possible.
- Use a ground impedance tester or micro-ohm meter to test the quality of earth ground connection at the chassis. This will insure good grounding between the chassis, rack, and earth ground.

NOTE

Because building codes vary worldwide, Extreme Networks strongly recommends that you consult an electrical contractor to ensure proper equipment grounding for your specific installation.

Space Requirements for the Rack

Provide enough space in front of and behind the switch so that you can service it easily. Allow a minimum of 48 inches (122 cm) in front of the rack and 24 inches (61 cm) behind the rack. When using a relay (two-post) rack, provide a minimum of 24 inches (61 cm) of space behind the mounted equipment. Extra room on each side is optional.

WARNING!

A BlackDiamond chassis does not have a switch for turning power to the unit on and off. For systems using an AC power supply, power to the chassis is disconnected by removing the wall plug from the electrical outlet. For systems using a DC SSI power supply, power to the chassis can be turned off by lifting the handle on the power supply or by de-energizing the circuit that feeds the power supply, which is usually accomplished by turning off a circuit breaker.

Securing the Rack

The rack should be attached to the wiring closet floor with 3/8-inch (9.5 mm) lag screws or equivalent hardware. The floor under the rack should be level within 3/16-inch (5 mm). Use a floor-leveling cement compound if necessary or bolt the racks to the floor as shown in [Figure 22](#).

Figure 22: Properly Secured Rack

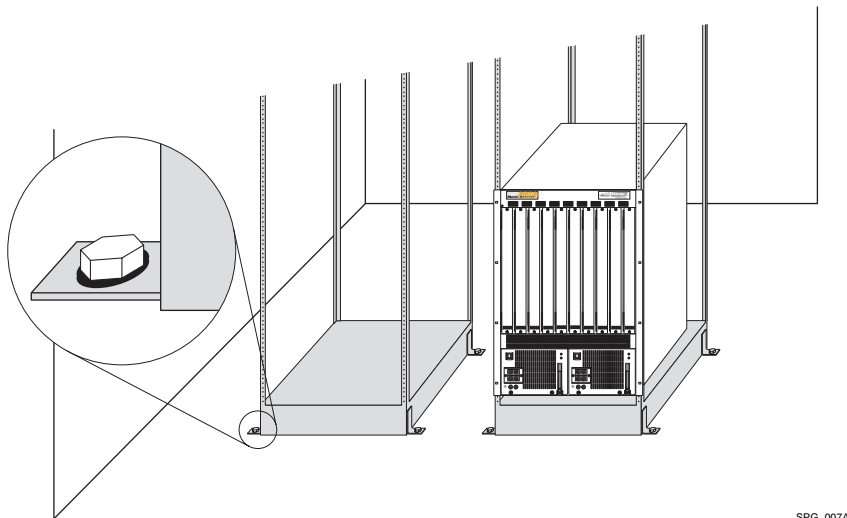

SPG_007A

Brace open equipment racks if the channel thickness is less than 1/4 inch (6.4 mm).

Evaluating and Meeting Cable Requirements

This section addresses requirements for the cable you should use when installing your network equipment. It includes:

- [Cabling Standards](#)
- [Cable Labeling and Record Keeping](#)
- [Installing Cable](#)
- [RJ-45 Connector Jackets](#)
- [Radio Frequency Interference](#)

Cabling Standards

Extreme Networks recommends using the Building Industry Consulting Service International (BICSI) Registered Communications Distribution Designer (RCDD), which is globally recognized as a standard in site planning and cabling. For information, go to:

<http://www.bicsi.org>

Cable Labeling and Record Keeping

A reliable cable labeling system is essential when planning and installing a network. Maintaining accurate records helps you to:

- Relocate devices easily.
- Make changes quickly.
- Isolate faults in the distribution system.
- Locate the opposite end of any cable.
- Know the types of network devices that your cabling infrastructure can support.

Consider the following recommendations when setting up a cable labeling system suitable for your installation:

- Identify cables by securely attaching a label to all cable ends.
- Assign a unique block of sequential numbers to the group of cables that run between each pair of wiring closets.
- Assign a unique identification number to each equipment rack.
- Identify all wiring closets by labeling the front panel of your Extreme Networks equipment and other hardware.
- Keep accurate and current cable identification records.
- Post records near each equipment rack. Include the following cable drop information: the cable source, destination, and jumper location.

Installing Cable

Consider the following recommendations when you connect cable to your network equipment:

- Examine cable for cuts, bends, and nicks.
- Support cable using a cable manager that is mounted above connectors to avoid unnecessary weight on the cable bundles.
- Use cable managers to route cable bundles to the left and right of the network equipment to maximize accessibility to the connectors.
- Provide enough slack, approximately 2 to 3 inches (5.08 to 7.62 cm), to provide proper strain relief as shown in [Figure 23](#).
- Bundle cable using velcro straps to avoid injuring cables.
- If you build your own cable, be sure that cable is properly crimped.
- When installing a patch panel using twisted pair wiring, untwist no more than 1 inch (2.54 cm) of the cable to avoid radio frequency (RF) interference.
- Discharge the RJ-45 Ethernet cable before plugging it into a port on the switch.
- When required for safety and fire rating requirements, use plenum-rated cable. See your local building codes for determining when it is appropriate to use plenum-rated cable, or refer to IEC standard 850.
- Keep all ports and connectors free of dust.



WARNING!

Unshielded twisted pair (UTP) cable can build up ESD charges when being pulled into a new installation. Before connecting any category 5 UTP cable to the switch, discharge ESD from the cable by plugging the RJ45 into a LAN Static Discharge device or use an equivalent method.

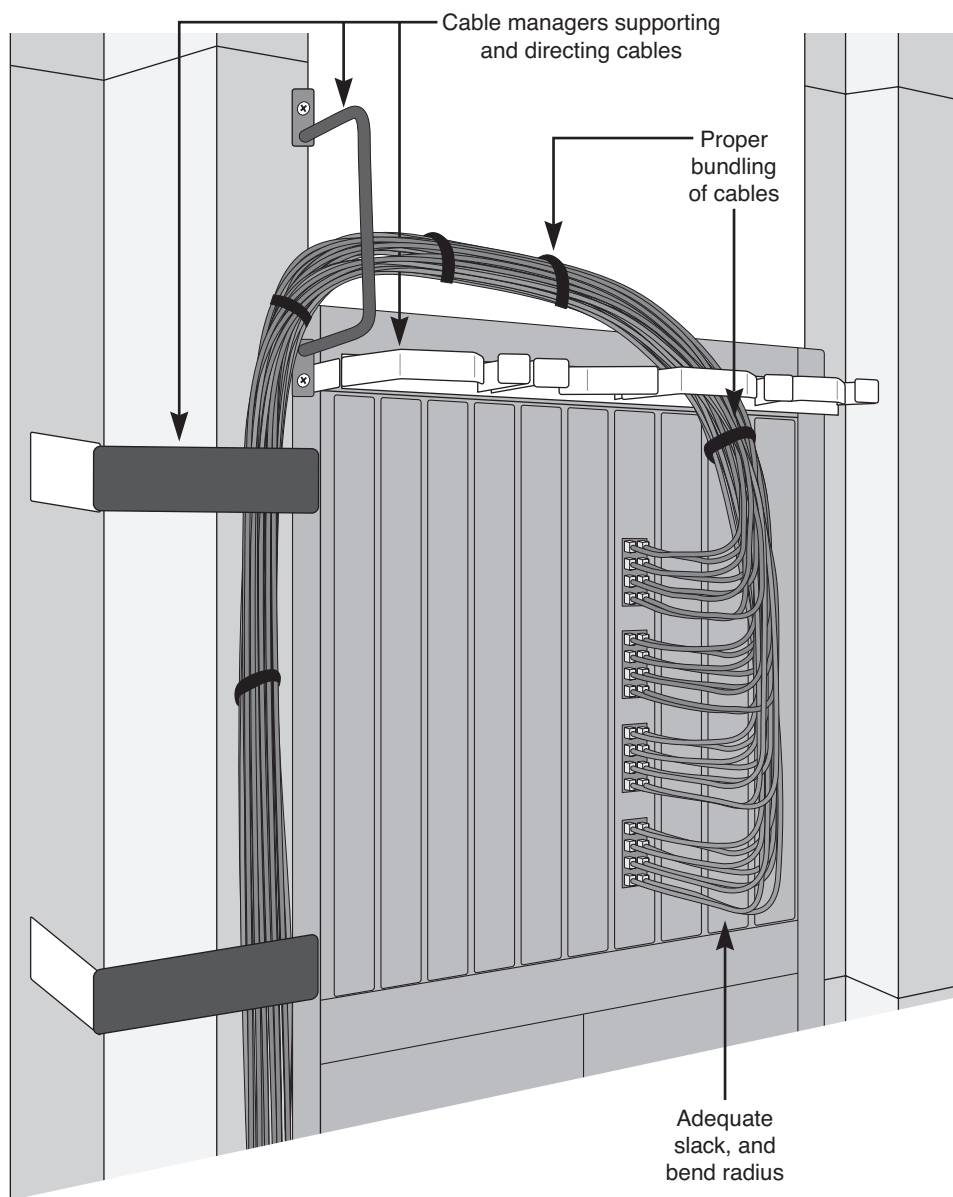
Figure 23: Properly Installed and Bundled Cable

SPG_008

Fiber Optic Cable

Fiber optic cable must be handled carefully during installation. Every cable has a minimum bend radius, for example, and fibers will be damaged if the cables are bent too sharply. It is also important not to stretch the cable during installation. We recommend that the bend radius for fiber optic cable equal 2 inches (5.08 cm) minimum for each 90-degree turn as shown in [Figure 24](#).



NOTE

Kinks and sharp bends can destroy or impair the cable's ability to convey light pulses accurately from one end of the cable to the other. Use care in dressing the optical fiber cables: provide satisfactory strain relief to support the

cable and maintain an adequate bend radius at all cable turns, particularly where the cable connects to the I/O module.

Figure 24: Bend Radius for Fiber Optic Cable

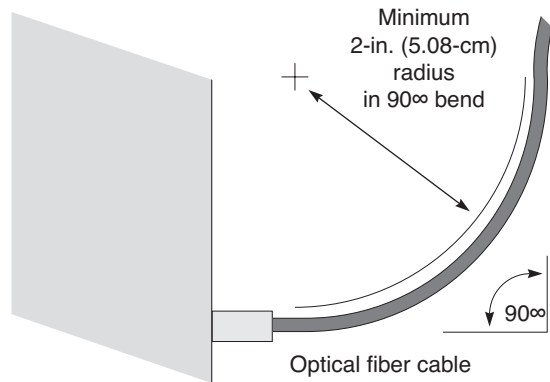

SPG_002

Cable Distances

Table 14 shows cable media types and maximum distances that support reliable transmission in accordance with international standards except where noted.

Table 14: Media Types and Maximum Distances

Standard	Media Type	Mhz•Km Rating	Maximum Distance (Meters)
1000BASE-SX (850 nm optical window)	50/125 µm multimode fiber	400	500
	50/125 µm multimode fiber	500	550
	62.5/125 µm multimode fiber	160	220
1000BASE-LX (1300 nm optical window)	62.5/125 µm multimode fiber	200	275
	50/125 µm multimode fiber	400	550
	50/125 µm multimode fiber	500	550
	62.5/125 µm multimode fiber	500	550
1000BASE-LX70 (1550 nm optical window)	10/125 µm single-mode fiber	–	5,000
	10/125 µm single-mode fiber*	–	10,000
	10/125 µm single-mode fiber	–	70,000
1000BASE-T	Category 5 and higher UTP cable	–	100
100BASE-TX	Category 5 and higher UTP cable	–	100
10BASE-T	Category 3 and higher UTP cable	–	100

* Proprietary to Extreme Networks. Connections between two Extreme Networks 1000BASE-LX interfaces that use 10/125 µm single-mode fiber can use a maximum distance of 10,000 meters.

RJ-45 Connector Jackets

Use RJ-45 cable with connector jackets that are flush with the connector or that have connectors with a no-snag feature.

Using cable with jackets that are wider than the connectors can cause:

- Connectors that are not properly aligned with the port.
- Crowded cable installation, which can cause connectors to pop out of the port.

Figure 25 shows examples of connector jacket types that are not recommended as well as those that are recommended.

Figure 25: RJ-45 Connector Jacket Types

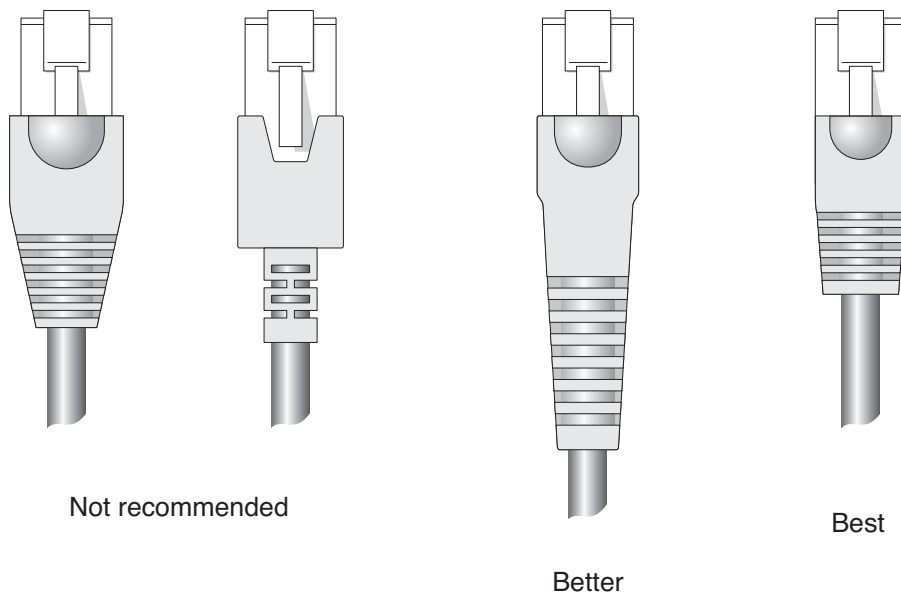

SPG_001

Radio Frequency Interference

If you use UTP cabling in an installation, take precautions to avoid RF interference. RF interference can cause degradation of signal quality, and, in an Ethernet network environment, can cause excessive collisions, loss of link status, or other physical layer problems that can lead to poor performance or loss of communication.

To prevent RF interference, avoid the following devices or situations:

- Attaching UTP cable to AC power cables
- Routing UTP cable near antennas, such as a ham radio antenna
- Routing UTP cable near equipment that could exhibit RF interference, such as ARC welding equipment
- Routing UTP cable near electrical motors that contain coils
- Routing UTP cable near air conditioner units
- Routing UTP cable near electrical transformers

In areas or applications where these situations cannot be avoided, use fiber optic cabling or shielded twisted pair cabling (STP).

Meeting Power Requirements

This section describes power requirements, including:

- [Power Supply Requirements](#)
- [AC Power Cable Requirements](#)
- [Uninterruptible Power Supply Requirements](#)

Power Supply Requirements

Adhere to the following requirements to operate your Extreme Networks equipment safely:

- Be sure that your equipment is placed in an area that accommodates the power consumption and component heat dissipation specifications.
- Be sure that your power supply meets the site power or AC power requirements of the network equipment.
- When connecting power to installed equipment, avoid connecting through an extension cord or power strip.
- If your switch includes more than one power supply, connect each power supply to a different, independent power source.

If a power source fails, it will affect only the switch power supply to which it is connected. If all switch power supplies are connected to a single power source, the entire switch is vulnerable to a power source failure.

For power specifications of the BlackDiamond 12800 series switches, see [Appendix B, “Technical Specifications.”](#)

AC Power Cable Requirements

Use an AC power cable appropriate for your country. Check your local electrical codes and regulatory agencies for power cable requirements. The countries listed in [Table 15](#) have additional requirements as listed in the table.

Table 15: AC Power Cable Requirements

Country	Requirements
USA and Canada	<ul style="list-style-type: none"> The cable set must be UL-approved and CSA-certified. The minimum specification for the flexible cable is No. 18 AWG (1.5 mm²), Type SVT or SJT, 3-conductor. The cable set must have a rated current capacity of at least the amount rated for each specific product. The attachment plug must be either an Earth-grounding type with a NEMA 5-15P (10 A, 110 V) configuration or a NEMA L6-15P (10 A, 208/240 V)
Denmark	The supply plug must comply with section 107-2-D1, standard DK2-1a or DK2-5a.
Switzerland	The supply plug must comply with SEV/ASE 1011.
Argentina	The supply plug must comply with Argentinian standards.



NOTE

When using dual power supplies, make sure that each AC power supply attaches to an independent power source.

Replacing the Power Cable

If the power cable plug is unsuitable and must be replaced, connect the power supply wires for the switch according to the following scheme:

- Brown wire to the Live (Line) plug terminal, which may be marked with the letter “L” or colored red.
- Blue wire to the Neutral plug terminal, which may be marked with the letter “N” or colored black.
- Yellow/Green wire to the Ground plug terminal, which may be marked with the letter “E” (the Earth symbol) or colored yellow/green.

Uninterruptible Power Supply Requirements

An uninterruptible power supply (UPS) is a device that sits between a power supply (such as a wall outlet) and a device (such as a switch) to prevent outages, sags, surges, and bad harmonics from adversely affecting the performance of the device.

A UPS traditionally can perform the following functions:

- Absorb relatively small power surges.
- Smooth out noisy power sources.
- Continue to provide power to equipment during line sags.

- Provide power for a period of time after a blackout has occurred.

In addition, some UPS devices or UPS plus software combinations provide the following functions:

- Automatically shut down equipment during long power outages.
- Monitor and log power supply status.
- Display the voltage (current draw) of the equipment.
- Restart equipment after a long power outage.
- Display the voltage currently on the line.
- Provide alarms on certain error conditions.
- Provide short-circuit protection.

Selecting a UPS

To determine UPS requirements for your switch, answer these questions:

- What are the amperage requirements?
- What is the longest potential time period that the UPS would be required to supply backup power?
- Where will the UPS be installed?
- What is the maximum transition time that your installation will allow?



NOTE

Extreme Networks recommends that you use a UPS that provides online protection.

Calculating Volt-Amperage Requirements

To determine the minimum volt-amperage requirements for your UPS:

- 1 Locate the voltage and amperage requirements for each piece of equipment. These numbers are usually located on a sticker on the back or bottom of your equipment. Then multiply the numbers together to get Volt-Amperes (VA):

$$\text{VA} = \text{Volts} \times \text{Amperes}$$

- 2 Add the VA from all the pieces of equipment together to find the total VA requirement.

To determine the minimum volt-amperage requirements for your UPS, we recommend that you add 30% to the total.

UPS Transition Time

Transition time is the time that is necessary for the UPS to transfer from utility power to full-load battery power. For Extreme Networks products, a transition time of less than 20 milliseconds is required for optimum performance.

Applicable Industry Standards

For more information, see the following ANSI/TIA/EIA standards:

- ANSI/TIA/EIA-568-A—discusses the six subsystems of a structured cabling system.

- ANSI/TIA/EIA-569-A—discusses design considerations.
- ANSI/TIA/EIA-606—discusses cabling system administration.
- ANSI/TIA/EIA-607—discusses commercial building grounding and bonding requirements.

You can access these standards at:

<http://www.ansi.org>

or

<http://www.tiaonline.org>

5

Installing the BlackDiamond 12800 Series Chassis

This chapter includes the following sections:

- [Unpacking the BlackDiamond 12804 Chassis on page 58](#)
- [Rack-Mounting the BlackDiamond 12804 Chassis on page 62](#)
- [Unpacking the BlackDiamond 12802 Chassis on page 64](#)
- [Rack-Mounting the BlackDiamond 12802 Chassis on page 66](#)
- [Grounding the BlackDiamond 12800 Series Chassis on page 68](#)
- [Initial Management Access on page 70](#)

This chapter describes how to install the following BlackDiamond chassis models:

- BlackDiamond 12804 chassis
- BlackDiamond 12802 chassis

The BlackDiamond 12800 series chassis fits into a standard 19-inch (48.26 cm) rack. You can install the switch either flush against the back of the rack or in a mid-mount position to give you more access behind the rack.



NOTE

Read the information in this chapter thoroughly before you attempt to install the BlackDiamond 12800 series switch.



CAUTION

Correct lifting of the BlackDiamond 12800 series chassis requires two people.

The BlackDiamond 12800 series chassis should be empty before being lifted. This will also prevent damage to the system components due to possible system chassis flex when lifting.

Unpacking the BlackDiamond 12804 Chassis



NOTE

Do not remove the nylon straps until you are ready to open the chassis package.

To unpack the BlackDiamond 12804 chassis:

- 1 Remove the nylon straps from around the shipping carton.
- 2 Open the top flaps and remove the accessories and documentation pack from the shipping carton (see [Figure 26](#)). Lift out the packing foam.

Figure 26: Removing Accessories from the BlackDiamond 12804 Chassis Shipping Carton

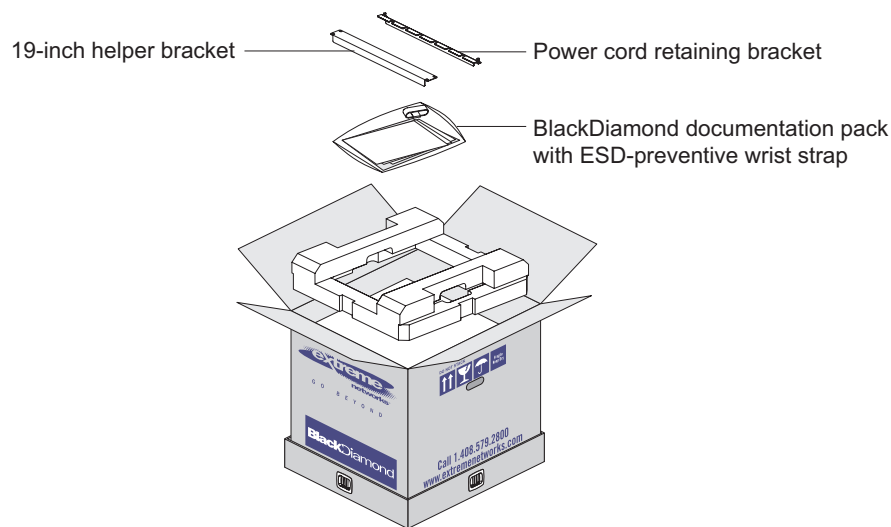

EX_110

- 3 Release the clip locks (see [Figure 27](#)).
 - a Place your thumb and index finger inside the clip lock to grasp the prongs.
 - b Squeeze the prongs inward, applying equal pressure on each side.
 - c Pull the prongs outward until the clip lock is released from the carton.
 Repeat these steps to release each of the remaining clip locks.

Figure 27: Clip Locks on the BlackDiamond 12804 Chassis Shipping Carton

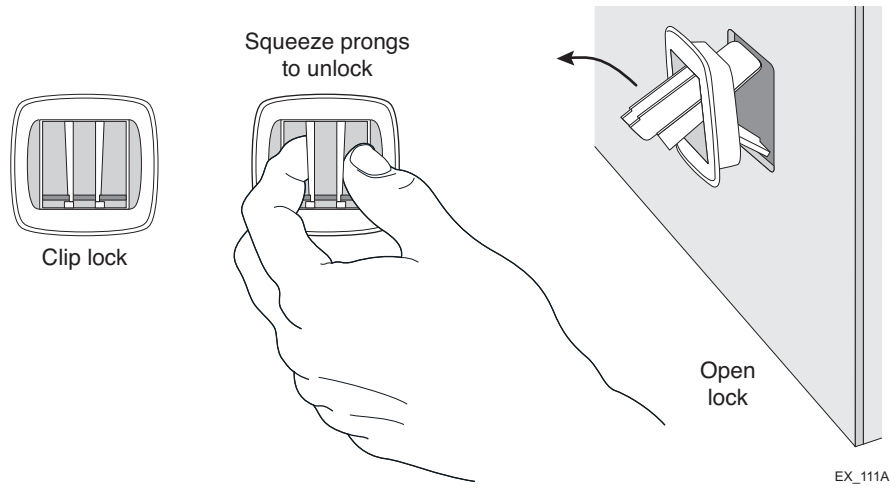

4 Slide the shipping carton up over the BlackDiamond 12804 chassis (see [Figure 28](#)).

Figure 28: Removing the Carton from the BlackDiamond 12804 Chassis

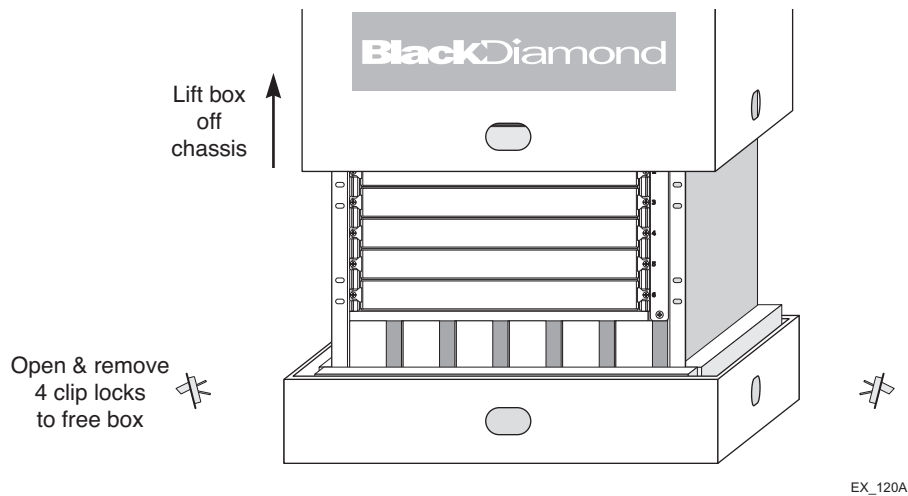

5 Unwrap the chassis.

- 6 At each side of the chassis, place one hand in the empty power supply bay and the other hand in the recessed hand-hold on the back panel of the BlackDiamond 12804 chassis. Carefully lift the chassis off the foam cushion and onto the floor (see [Figure 29](#)).

Figure 29: Correct Method for Lifting the BlackDiamond 12804 Chassis

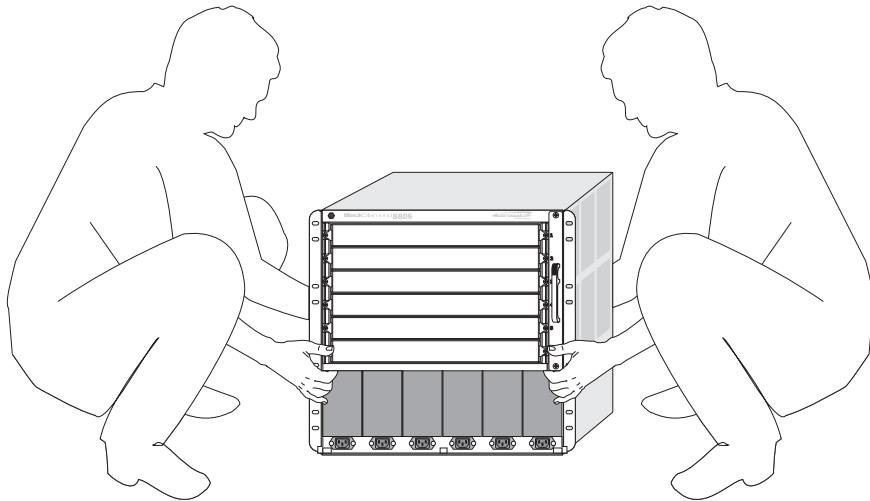

EX_112



CAUTION

Do not use the fan tray handle to lift or maneuver the BlackDiamond 12804 chassis. This handle is not designed to support the weight of the chassis.

Verify that the following items are included in the crate:

- BlackDiamond 12804 chassis with four installed blank front panels
- Power cord retaining bracket
- 19-inch helper bracket (installation tray)
- BlackDiamond documentation pack with ESD-preventive wrist strap



NOTE

Save all packaging, clip locks, and box pieces for future use in the event that the BlackDiamond 12804 chassis must be moved to another location or returned to Extreme Networks, Inc.

Rack-Mounting the BlackDiamond 12804 Chassis

The BlackDiamond 12804 chassis has attached rack-mounting flanges for a front-mount rack installation. To install the chassis in a mid-mount position, attach optional mid-mount brackets, as described in [“Attaching the BlackDiamond 12804 Mid-Mount Brackets”](#) on page 61.

Pre-installation Requirements

The following tools, equipment, and resources are required for installing the BlackDiamond 12804 chassis:

- ESD-preventive wrist strap (provided)
- 19-inch helper bracket (provided)
- For installing the chassis in a mid-mount position in the rack:
 - Optional BlackDiamond 8806/12804 mid-mount kit, part number 65046. Order this kit separately from the chassis.
 - #2 Phillips screwdriver
- Rack-mount screws appropriate for your organization's rack system, as follows:
 - 4 screws to attach the helper bracket
 - 12 screws to secure the BlackDiamond 12804 chassis in the rack

The screw size will vary based on your organization's rack system; screws are not provided.
- Screwdriver appropriate for the rack-mounting screws you will use

The screwdriver size will vary based on the requirements of your organization's rack system.

Attaching the BlackDiamond 12804 Mid-Mount Brackets

To install the BlackDiamond 12804 switch in a mid-mount position in the rack, attach the optional mid-mount brackets.

To attach the mid-mount brackets:

- 1 Place the empty BlackDiamond 12804 chassis in an upright position on a secure flat surface.



CAUTION

The BlackDiamond 12804 chassis weighs almost 65 pounds. Proper lifting and moving of the chassis requires two people.

- 2 Determine the locations for the mid-mount brackets.



NOTE

Each side of the chassis has two sets of mounting holes to provide two positions for attaching the mid-mount brackets.

- 3 Identify the left and right brackets.

Each mid-mount bracket is clearly marked for placement on either the right or left side, as viewed from the front of the chassis.

- 4 On each side of the chassis, attach the appropriate mid-mount bracket using the eight screws provided in the kit (see [Figure 30](#)).

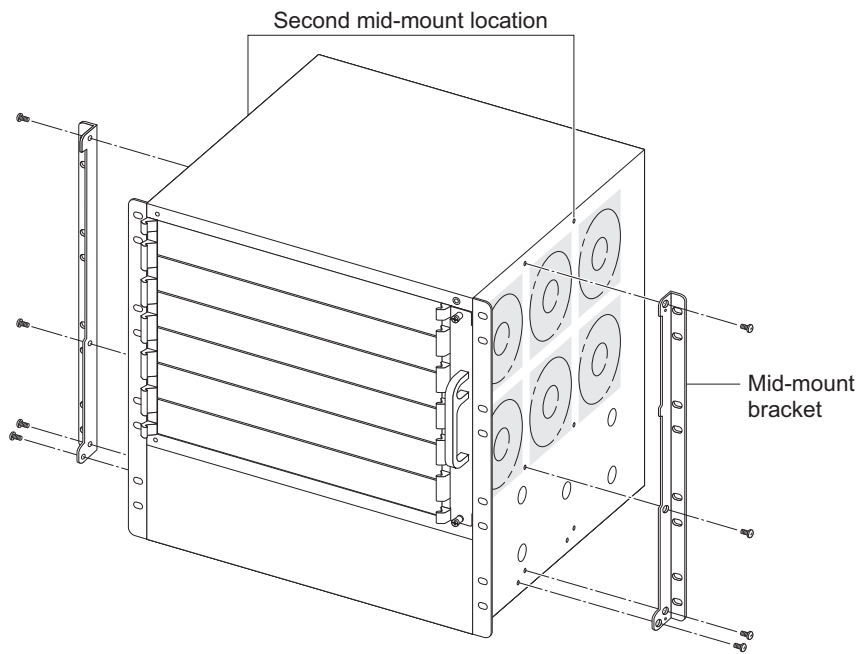
Figure 30: Attaching the Mid-mount Brackets to the BlackDiamond 12804 Chassis

EX_136

Rack-Mounting the BlackDiamond 12804 Chassis

To mount the BlackDiamond 12804 chassis in a rack:

- 1 Locate the 19-inch helper bracket that is shipped with the BlackDiamond 12804 chassis.
- 2 Identify the rack location where the chassis will be installed.
- 3 Using four rack mounting screws, attach the helper bracket to the system rack immediately below the chassis location (see [Figure 31](#)).

You must provide the screws for attaching the helper bracket.

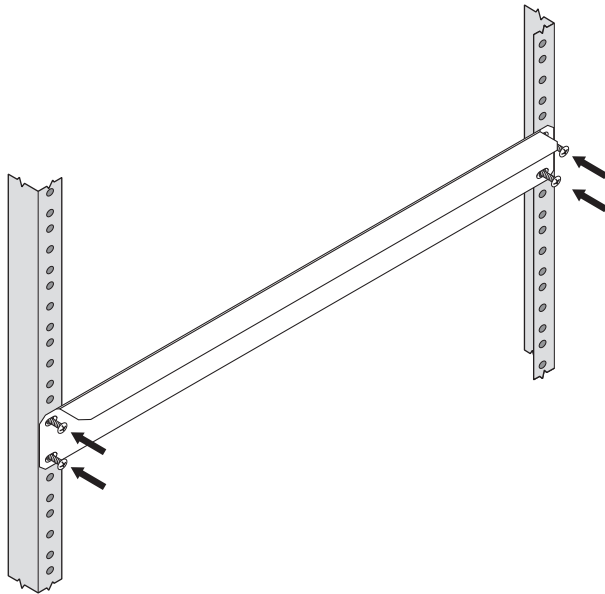
Figure 31: Attaching the 19-inch Helper Bracket to the System Rack

EX_086A

- 4 Lift the back of the empty BlackDiamond 12804 chassis onto the helper bracket.
- 5 Slowly guide the chassis into the system rack until the mounting brackets are flush against the rack uprights.
- 6 Attach the chassis to the system rack using eight rack mounting screws. (Screws are not provided.) Be sure that the screws are secure. Refer to [Figure 32](#) for the screw locations.

i **NOTE**

Figure 32 shows a standard rack mount. For mid-mount installation, use the same mounting locations shown in the figure, but insert the screws through the designated slot locations of the mid-mount brackets.

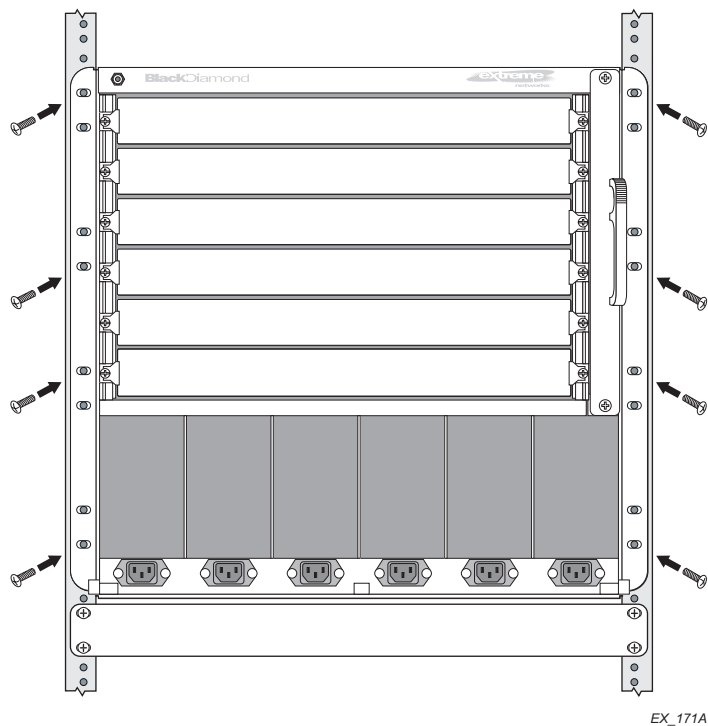
Figure 32: Securing the BlackDiamond 12804 Chassis to a Rack

- 7 Remove the helper bracket from the system rack after the chassis is secured. Save the bracket for future use if you remove the chassis from the rack.

Unpacking the BlackDiamond 12802 Chassis



CAUTION

Proper lifting of the BlackDiamond 12802 chassis requires two people.

To unpack the BlackDiamond 12802 chassis:

- 1 Break the inspection seal and cut the packing tape on the top of the shipping carton.
- 2 Open the top of the carton and remove the documentation pack (see [Figure 33](#)).
- 3 Remove the packing foam on top of the chassis (see [Figure 33](#)).
- 4 At the side of the chassis, remove the package of mounting brackets and hardware (see [Figure 33](#)).

Figure 33: Unpacking the BlackDiamond 12802 Chassis

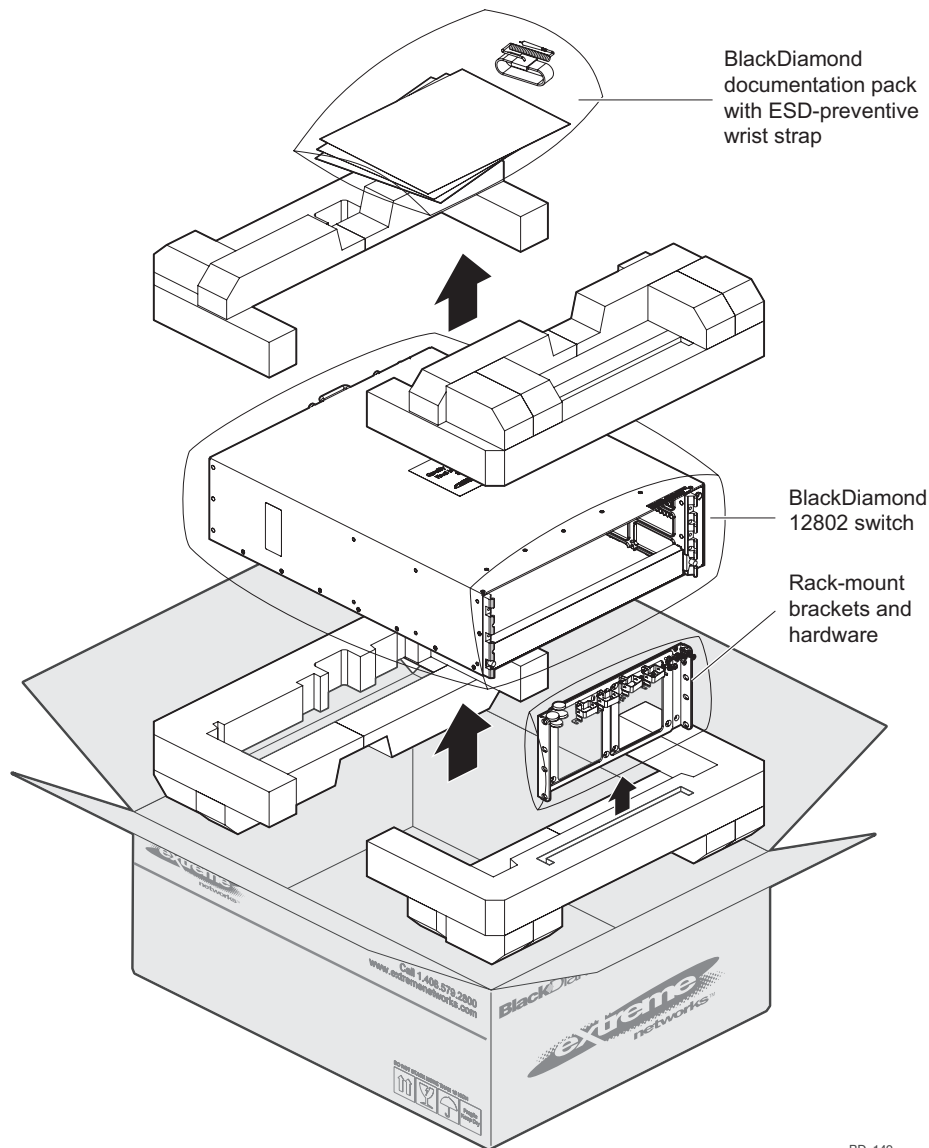

BD_149

- 5 To lift the BlackDiamond chassis, on each side have one person support the bottom of the chassis as you lift the chassis off the bottom foam cushion.

**CAUTION**

Do not lift the chassis using the top of the front opening. The weight of the chassis may cause the enclosure to deform.

Set the chassis on a secure, flat work surface.

- 6 Break the inspection seal on the packing bag and remove the chassis from the bag.

**NOTE**

Save the box and all packaging for future use in case the BlackDiamond 12802 chassis must be returned to Extreme Networks, Inc.

Rack-Mounting the BlackDiamond 12802 Chassis

The BlackDiamond 12802 chassis is shipped with mounting brackets that allow you to position the mounting flanges at either the front or the middle of the chassis sides.

Required Tools and Equipment

In addition to the hardware shipped with the BlackDiamond 12802 chassis, you need the following tools and equipment to install the chassis in a rack:

- 8 rack system mounting screws
 - The screw size will vary based on your organization's rack system; screws are not provided.
- Screwdriver appropriate for the selected rack mounting screws

Front-Mounting a BlackDiamond 12802 Chassis

To front-mount the BlackDiamond 12802 chassis in a rack:

- 1 Place each mounting bracket against the switch chassis with the mounting flange at the front edge of the chassis ([Figure 34](#)).
- 2 Insert and tighten the provided flat-head screws to secure the brackets to the chassis.

Figure 34: Mounting Flanges at the Front

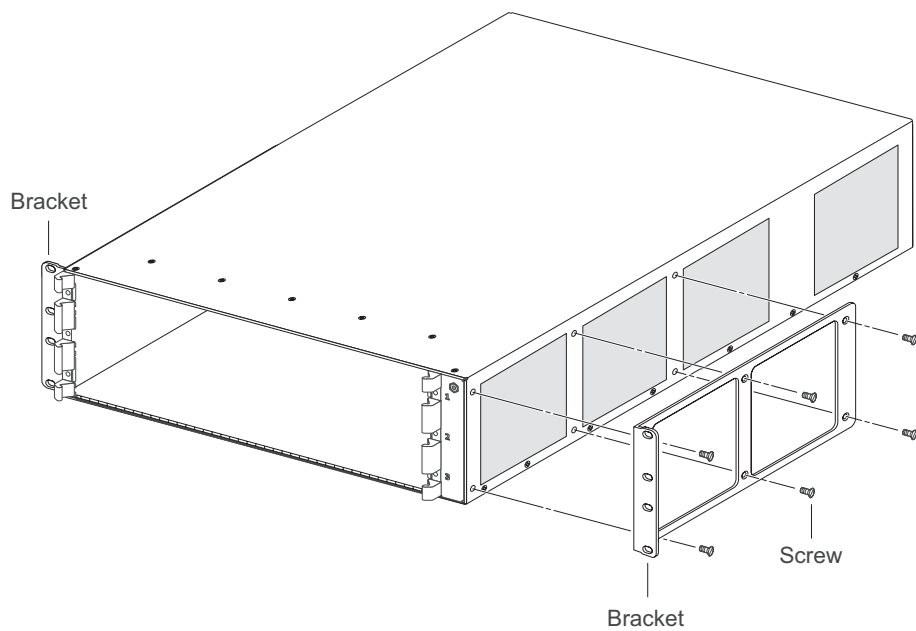

- 3 Slide the chassis into the system rack.

- 4 Attach the chassis to the system rack using eight rack system mounting screws (screws not provided). Refer to [Figure 35](#) for the screw locations.

Figure 35: Securing the BlackDiamond 12802 Chassis to the Rack (Front-mount Position)

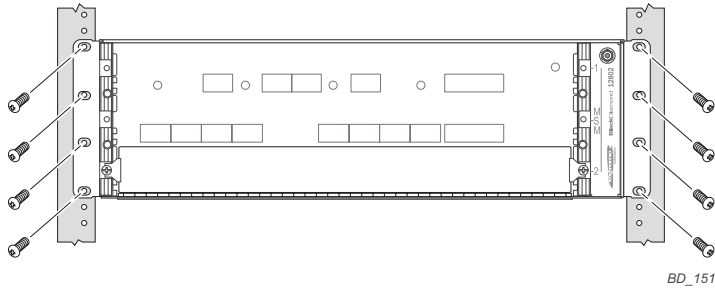

Mid-Mounting a BlackDiamond 12802 Chassis

To mid-mount the BlackDiamond 12802 chassis in a rack:

- 1 Place each mounting bracket against the switch chassis with the mounting flange at the middle of the chassis side ([Figure 36](#)).

Figure 36: Mounting Flanges at the Middle

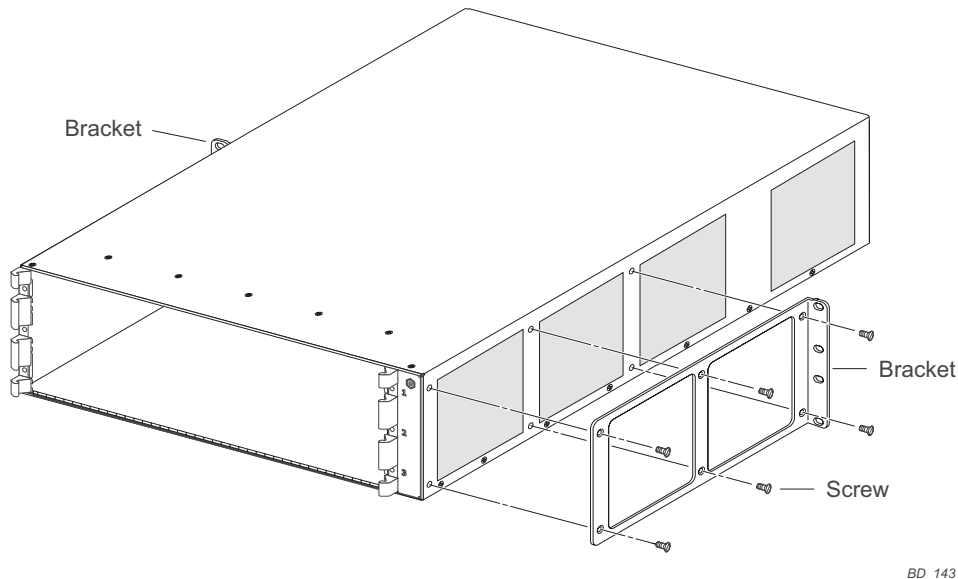

- 2 Insert and tighten the provided flat-head screws to secure the brackets to the chassis.
- 3 Slide the chassis into the equipment rack.
- 4 Attach the chassis to the system rack using eight rack system mounting screws (screws not provided). Refer to [Figure 37](#) for the screw locations.

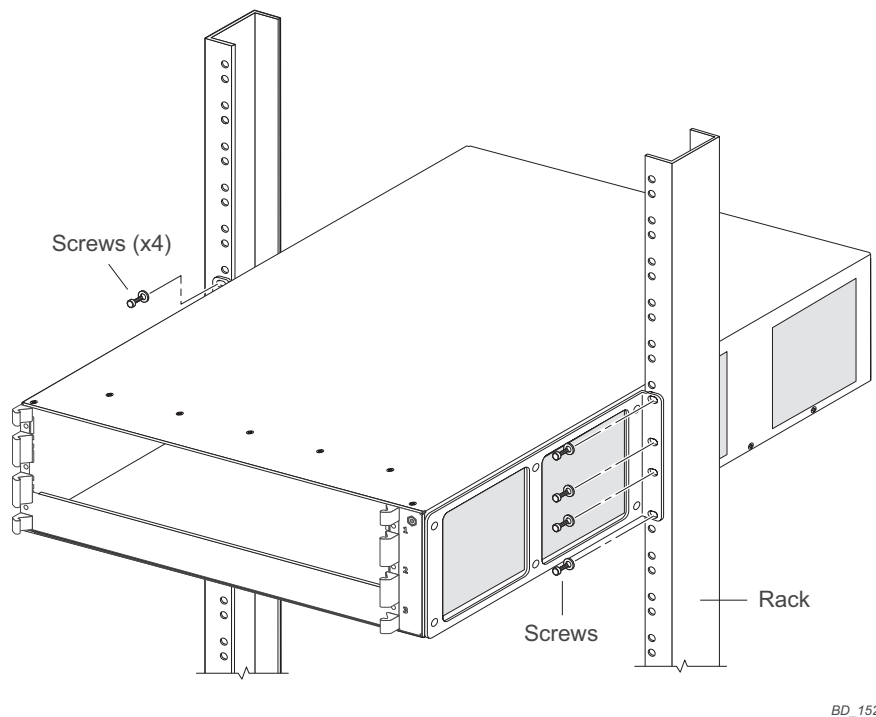
Figure 37: Securing the BlackDiamond 12802 Switch to the Rack (Mid-mount Position)

BD_152

Grounding the BlackDiamond 12800 Series Chassis

Although grounding the BlackDiamond 12800 series chassis is optional, it is recommended. A grounding point with integrated pem-nuts is provided on the back of the chassis.

You need the following materials to ground the chassis:

- Two 10-24 screws, 1 inch or shorter
- One copper, standard barrel 2-hole compression grounding lug, type LDC, equivalent to Panduit part number LCD4-14A-L or Thomas & Betts part number: LCN4-14
- Appropriate grounding wire for your system, based on the available input current for the power supply:
 - For AC systems using a 20A breaker per PSU (SSI AC), the chassis ground can be as small as 14 AWG.
 - For DC systems using a 40A breaker per PSU (SSI DC), the chassis ground can be as small as 10 AWG.

To ground the chassis:

- 1 Locate the grounding point on the back of the chassis (Figure 38 and figure)).

Figure 38: Back of BlackDiamond 12804 Chassis

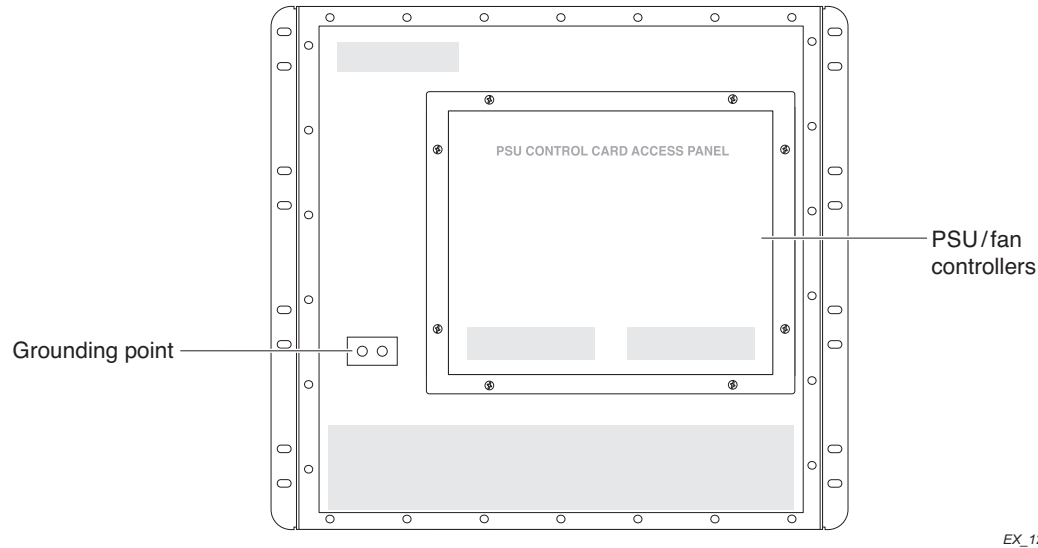
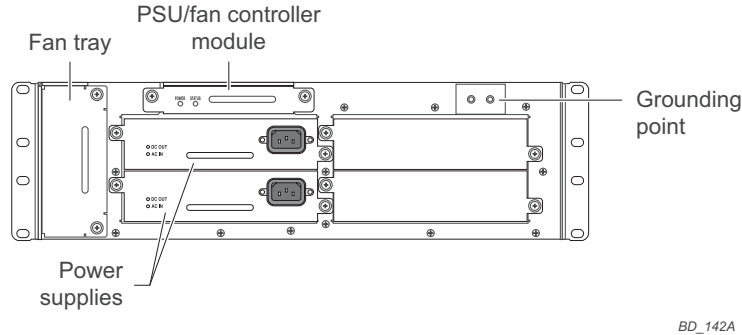

Figure 39: Back of BlackDiamond 12802 Chassis



- 2 Strip 0.5-inch (1.2-cm) of insulation from the stranded copper wire cable.
- 3 Insert the stripped wire into the cable lug.



CAUTION

Be sure that no copper is visible between the lug and the cable insulation.

- 4 Crimp the lug onto the cable according to the manufacturer's specifications.
- 5 Insert the screws through the lug and into the grounding point on the back of the chassis.
- 6 Connect the other end of the wire to a known reliable earth ground point at your site.

Initial Management Access

After your switch has completed all power on self-tests, it is operational. You can log in and configure an IP address for the default VLAN (named *default*).



NOTE

In BlackDiamond switches, the management port on the MSM is part of the management VLAN by default. Refer to “Management Ports” on page 16 for further details.

Connecting Equipment to the Console Port

Connection to the console port is used for direct local management. The console port settings are:

- Baud rate—9600
- Data bits—8
- Stop bit—1
- Parity—None
- Flow control—XON/XOFF

The terminal or PC with terminal-emulation software that you connect to an Extreme Networks switch must be configured with these settings. This procedure is described in the documentation supplied with the terminal.

Appropriate cables are available from your local supplier, or you can make your own. To ensure the electromagnetic compatibility of the unit, use only shielded serial cables. For information about the DB-9 console plug connector, see “Connector Pinouts” on page 153.

Logging In for the First Time

After your switch has completed all power on self-tests, it is operational. You can log in and configure an IP address for the default VLAN (named *default*).



NOTE

In BlackDiamond switches, the management port on the MSM is part of the management VLAN by default. Refer to "Management Ports" on page 16 for further details.

To manually configure the IP settings:

- 1 Connect a terminal or PC with terminal-emulation software to the MSM on the BlackDiamond switch or to the console port on the Summit switch.
- 2 At your terminal, press [Return] one or more times until you see the login prompt.
- 3 At the login prompt, enter the default user name *admin* to log on with administrator privileges. For example:

```
login: admin
```

Administrator capabilities allow you to access all switch functions.

- 4 The system will ask a series of questions about the default management settings, which allow all forms of management access for convenience in setting the initial configuration. Answer each question based on the level of security needed for the particular management access type.



NOTE

For more information about logging in to the switch and configuring switch management access, see the ExtremeXOS 12.0 Concepts Guide.

- 5 At the password prompt, press [Return].
The default user name *admin* has no password assigned to it. When you have successfully logged on to the system, the command line prompt displays the system name (for example, BlackDiamond12804>) in its prompt.



NOTE

For more information about how to assign a specific system name, see the ExtremeXOS 12.0 Concepts Guide.

- 6 Assign an IP address and subnetwork mask for VLAN *default* by typing:

```
configure vlan default ipaddress 123.45.67.8 255.255.255.0
```

Your changes take effect immediately.
- 7 Save your configuration changes so that they will be in effect after the next system reboot by typing:

```
save
```

The configuration is saved to the configuration database of the MSM modules in the switch.



NOTE

For more information about saving configuration changes, see the ExtremeXOS 12.0 Concepts Guide.

- 8 When you are finished with these tasks, log out of the switch by typing:

```
logout
```

6 Installing Power Supply Units

This chapter describes how to install power supply units in BlackDiamond 12800 series switches.

This chapter includes the following topics:

- [Safety on page 73](#)
- [BlackDiamond PSU Compatibility on page 74](#)
- [Extreme Networks 1200 W DC PSU on page 74](#)
- [Extreme Networks 700/1200 W AC PSU on page 81](#)
- [Extreme Networks 325 W DC Power Supply on page 88](#)
- [Extreme Networks 325 W AC Power Supply on page 94](#)

Safety

Only trained service personnel should perform service to Extreme Networks switches and their components. Trained service personnel have read all related installation manuals, have the technical training and experience necessary to be aware of the hazards to which they are exposed in performing a task, and are aware of measures to minimize the danger to themselves or other persons.

Before installing an Extreme Networks PSU into your network:

- Read the latest installation and safety information provided in this chapter and in [Appendix A, "Safety Information."](#)
- See [Appendix A, "Safety Information"](#) for additional information regarding regulatory compliance certifications.



NOTE

For central DC power connections, the 1200 W DC PSU and 325 W DC PSU are intended to be installed only in restricted access locations (dedicated equipment rooms, equipment closets, or the like) in accordance with Articles 110-16, 110-17, and 110-18 of the National Electric Code, ANSI/NFPA-70. All wiring methods involving the DC input cable assembly must be performed according to the relevant articles of the National Electrical Code.



CAUTION

Building codes vary worldwide; therefore, Extreme Networks strongly recommends that you consult an electrical contractor to ensure proper equipment grounding and power distribution for your specific installation.



WARNING!

Field operators must not attempt to open the PSU enclosure for any reason; the PSU does not contain user-serviceable parts. In the event of failure, return the defective PSU to Extreme Networks for repair or replacement.

BlackDiamond PSU Compatibility

The BlackDiamond power supply units are intended for use in specific BlackDiamond switches only. Table 16 lists the power supplies for use in the BlackDiamond 12800 series switches.

Table 16: PSUs for the BlackDiamond 12800 Series Switches

BlackDiamond Switch	Compatible PSU	Compatibility Notes
BlackDiamond 12804	700W/ 1200W AC PSU OR 1200W DC PSU	Extreme Networks does not recommended using the 700/1200 W AC PSU in conjunction with a 1200W DC PSU.
BlackDiamond 12802	325 W AC PSU, Model # 65021 OR 325 W DC PSU, Model # 65022	Extreme Networks does not recommended using the 325 W AC PSU in conjunction with the 325 W DC PSU.

Extreme Networks 1200 W DC PSU

The Extreme Networks 1200 W DC UL-listed accessory power supply unit (Model # 60021/PS 2350) is compatible with the BlackDiamond 12804 switch. The power supply bay in the BlackDiamond 12804 switch can accommodate up to six hot-swappable Extreme Networks 1200 W DC PSUs. You cannot install the 1200W DC PSU in a BlackDiamond 12802 switch.



NOTE

Extreme Networks does not recommended installing the 1200 W DC PSU with any Extreme Networks AC PSU in the same BlackDiamond 12804 system. Extreme Networks recommends that DC and AC PSU units not be used together in the same BlackDiamond switch.



NOTE

For central DC power connections, the 1200 W DC PSU is intended to be installed only in restricted access locations (dedicated equipment rooms, equipment closets, or the like) in accordance with Articles 110-16, 110-17, and 110-18 of the National Electric Code, ANSI/NFPA-70.



CAUTION

Building codes vary worldwide; therefore, Extreme Networks strongly recommends that you consult an electrical contractor to ensure proper equipment grounding and power distribution for your specific installation.



WARNING!

Field operators must not attempt to open the 1200 W DC PSU enclosure for any reason; the PSU does not contain user-serviceable parts. In the event of failure, return the defective 1200 W DC PSU to Extreme Networks for repair or replacement.

Minimum Software Required

You must be running ExtremeWare XOS version 11.3 or later for the system to recognize the DC PSU.

Pre-Installation Requirements

You need the following tools and equipment to install or remove a 1200 W DC PSU:

- ESD-preventive wrist strap
- Input DC power cable (provided with the DC PSU)
- -48 V DC power source capable of providing 50 A dedicated power to each of the 1200 W DC PSUs installed in the switch
- Thermal protective gloves (required for removal)

Installing the DC Wiring

The input DC cable for the DC PSU is supplied with the 1200 W DC PSU (see [Figure 40](#)); you *must* use this cable with the DC PSU.

Figure 40: Input DC Power Cable for the 1200 W DC PSU

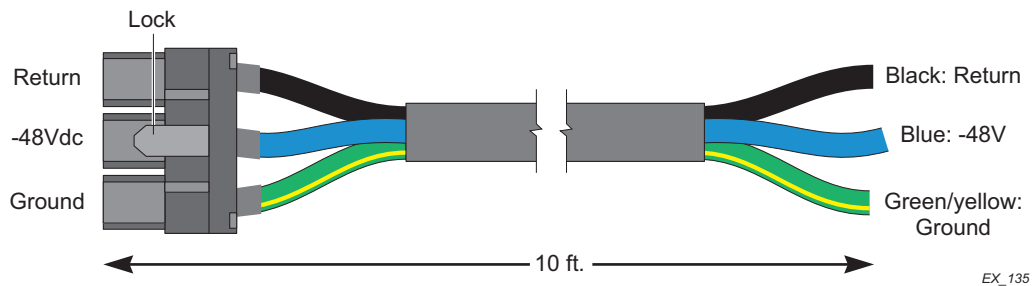

Each 1200 W DC PSU must be powered by a 50 A dedicated power source that delivers -40 to -72 VDC of constant power. Power distribution to the 1200 W DC PSU shall be provided using the -48 VDC harness provided. Power to the 1200 W DC PSU can be from either a 50 A UL-approved overcurrent protection breaker or an SELV- approved power source in accordance with IEC 60950-1 utilizing 50 A overcurrent protection.

The input DC cable has an input connector on one end and precut wire on the other end that goes to the DC power source. The connector end has a locking mechanism that locks onto the DC PSU to prevent accidental removal of the input DC cable.

If necessary, use appropriate termination lugs for 8 AWG (10 mm²) copper-stranded wire on cable ends of the cable to connect to the DC power source.

The blue termination (-48 V) connects to a 50 A overcurrent protection circuit device, and the black (return) termination connects directly to the RTN bus of the DC power source. The green/yellow termination (ground) must connect to the same earth ground point as the switch.

Installing an Extreme Networks 1200 W DC PSU

To install an Extreme Networks 1200 W DC PSU:

- 1 Attach an ESD-preventive wrist strap to your wrist and connect the metal end to the ground receptacle on the top-left corner of the switch front panel.



CAUTION

Be sure that the grounding point on the back of the switch is securely connected to earth ground. For information about grounding the switch, see [“Grounding the BlackDiamond 12800 Series Chassis” on page 68](#).

- 2 Verify that the 1200 W DC PSU is right side up, and press the yellow locking lever to the left while lifting the handle (see [Figure 41](#)).



NOTE

Do not connect the input DC cable to the DC PSU before inserting the DC PSU into the switch.

Figure 41: Locking Handle on the 1200 W DC PSU

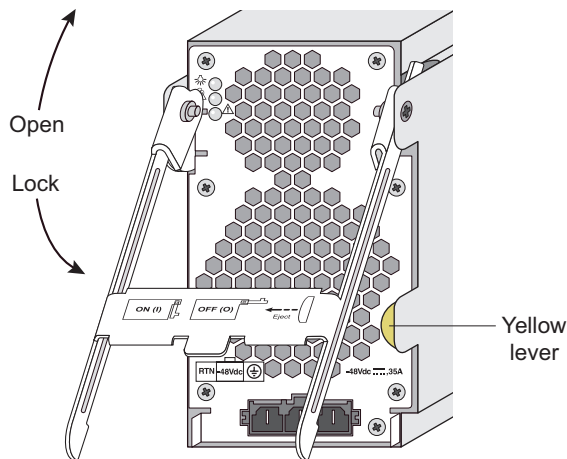

EX_130

- Carefully slide the 1200 W DC PSU all the way into the power supply bay (see [Figure 42](#)).
Be sure that the DC PSU is fully seated in the switch.

**CAUTION**

Do not slam the 1200 W DC PSU into the system switch backplane.

Figure 42: Inserting the 1200 W DC PSU into the Power Supply Bay

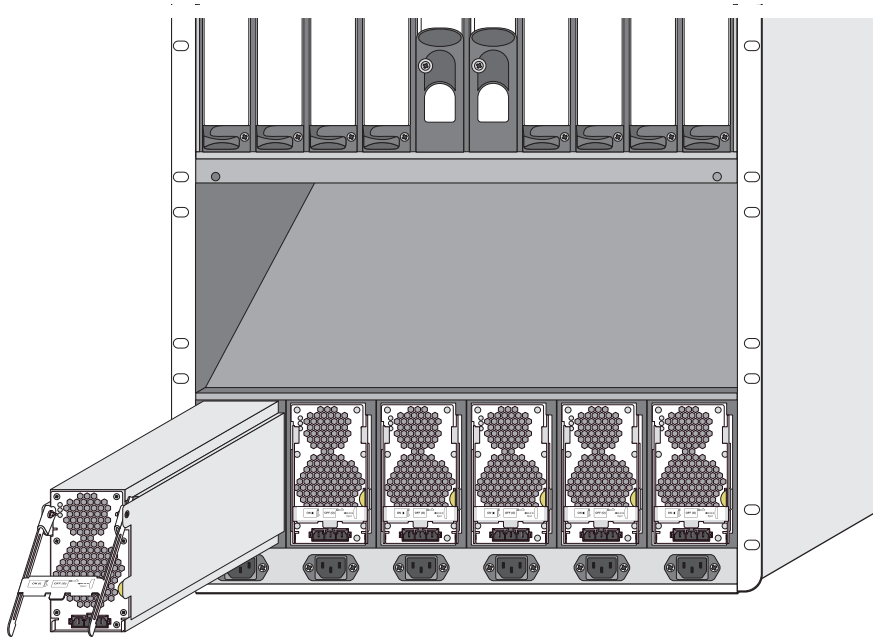

EX_131

- Connect the input DC cable to the front of the 1200 W DC PSU as shown in [Figure 43](#).

**NOTE**

An AC power cord is not required for proper functioning of the DC PSU.

- Rotate the locking handle down to latch the input cable connector onto the DC PSU.

**CAUTION**

Always verify that the DC circuit is not energized before you connect the input cable to the 1200 W DC PSU.

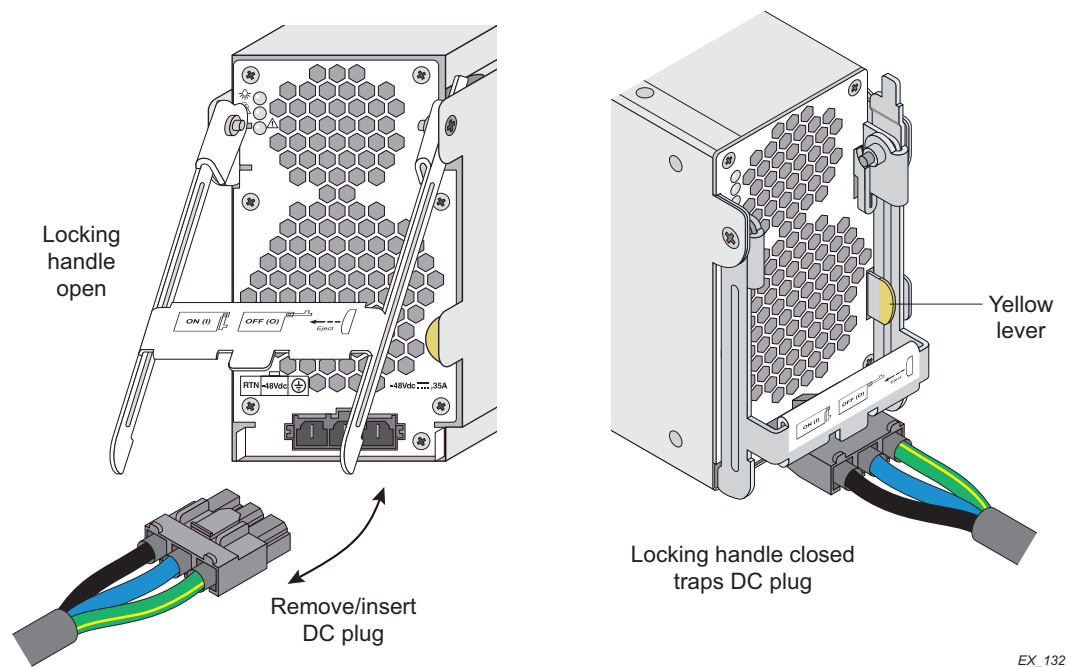
Figure 43: Connecting the Cable to the 1200 W DC PSU

EX_132

- Secure the 1200 W DC PSU into the power supply bay by pushing down on the locking handle until it clicks into place.

**NOTE**

The DC PSU does not energize until the locking handle latches.

**CAUTION**

Use caution when routing the cable harnesses to minimize stress on the cables. It is recommended that the left most cable harness be routed across the switch and exit out the right side of the grate. The right most cable harness should be routed across the switch and exit out the left side of the grate. It is important to route each of the outer most cables out the opposite side of installation to maximize the bend radius and to avoid stress on the cables. The four middle cables can route in either direction.

- Energize the DC circuit for the 1200 W DC PSU.

To install additional 1200 W DC PSUs, repeat steps 2 through 6.

**NOTE**

Leave the ESD strap permanently connected to the switch, so that the strap is always available when you need to handle ESD-sensitive components.

Removing an Extreme Networks 1200 W DC PSU



CAUTION

The DC PSU may be hot to the touch; use thermal protective gloves when handling the 1200 W DC PSU during removal.

To remove an Extreme Networks 1200 W DC PSU:

- 1 Attach an ESD-preventive wrist strap to your bare wrist and connect the metal end to the ground receptacle on the top-left corner of the switch front panel (if not already attached).
- 2 De-energize the DC circuit for the 1200 W DC PSU that will be removed.
- 3 Press the yellow lever on the DC PSU to the left while lifting the handle up on the 1200 W DC PSU.
- 4 Disconnect the cable from the front of the DC PSU by pressing down the catch (see [Figure 44](#)) and pulling out the cable.

Figure 44: Disconnecting the Cable from the DC PSU

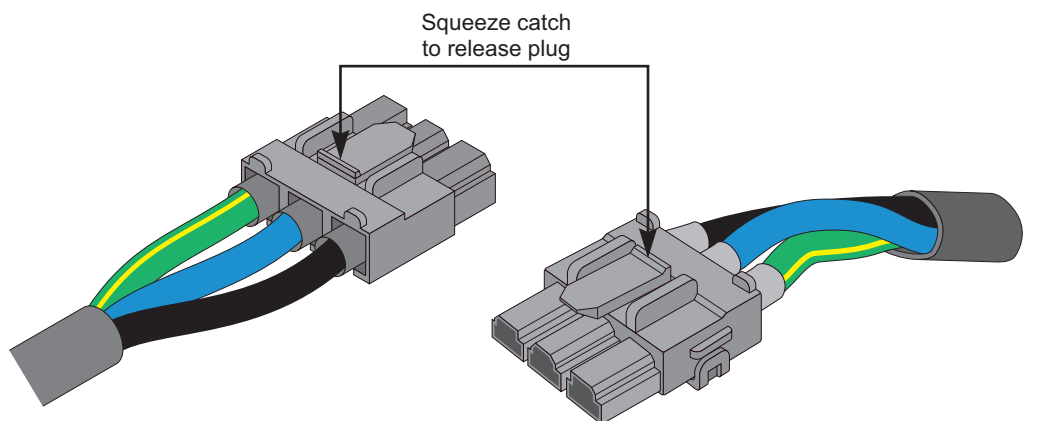

EX_133



WARNING!

Always be sure that the 1200 W DC PSU does not have the input cabled connected at any time when the DC PSU is not installed into the switch. Do not remove the DC PSU from the switch before disconnecting the input DC cable from the PSU.

- 5 Pull on the handle of the 1200 W DC PSU to slide it out of the power supply bay.
- 6 Wearing thermal protection gloves, place both hands underneath the 1200 W DC PSU to support the weight after it is pulled out from the switch.

To remove additional 1200 W DC PSUs, repeat steps 2 through 6.





NOTE

Leave the ESD strap permanently connected to the switch, so that the strap is always available when you need to handle ESD-sensitive components.

Front Panel LEDs

The front panel of the 1200 W DC PSU provides status LEDs. [Table 17](#) identifies the symbols and describes the LED behavior.

Table 17: Extreme Networks 1200 W DC PSU LEDs

PSU Condition	 Power Green	 Predictive Fail Amber	 Fail Amber
Power supply DC outputs working normally	On	Off	Off
DC input power present/standby output on	Blinking	Off	Off
Current limit on 48 V DC output	On	Off	Blinking
Predictive failure	On	Blinking	Off
No input power to this PSU only	Off	Off	On
No input power to any PSU	Off	Off	Off
Power supply failure	Off	Off	On

Extreme Networks 700/1200 W AC PSU

This section describes how to install and remove the Extreme Networks® 700/1200 W AC UL Listed Accessory power supply unit (Model # 60020/PS 2336).



NOTE

Extreme Networks does not recommend using the 700/1200 W AC PSU in combination with an Extreme Networks 1200W DC PSU in the same BlackDiamond 12804 system.



WARNING!

Field operators must not attempt to open the 700/1200 W AC PSU enclosure for any reason; the PSU does not contain user-serviceable parts. In the event of failure, return the defective 700/1200 W AC PSU to Extreme Networks for repair or replacement.

Pre-Installation Requirements



WARNING!

Extreme Networks 700/1200 W AC PSUs do not have switches for turning the unit on and off. Remove the wall plug from the electrical outlet to disconnect the power to an Extreme Networks 700/1200 W AC PSU. Make sure that this connection is always easily accessible.

Do not plug the power supply into an electrical outlet outside of the chassis, doing so would expose a hazardous energy and poses a potential shock and/or fire hazard.

You need the following tools and equipment to install or remove an Extreme Networks 700/1200 W AC PSU:

- ESD-preventive wrist strap
- Power supply cord (110 V AC, 220 V AC, or applicable to country of use)
- Thermal protective gloves (required for removal)

Installing an Extreme Networks 700/1200 W AC PSU



CAUTION

Make sure that the Extreme Networks 700/1200 W AC PSU circuit is not overloaded. Use proper over-current protection, such as a circuit-breaker, to prevent over-current conditions.

To install an Extreme Networks 700/1200 W AC PSU:

- 1 Attach an ESD-preventive wrist strap to your wrist and connect the metal end to the ground receptacle, which is located on the top-left corner of the switch front panel.
- 2 Verify that the Extreme Networks 700/1200 W AC PSU is right side up and the locking handle is open (see [Figure 45](#)).

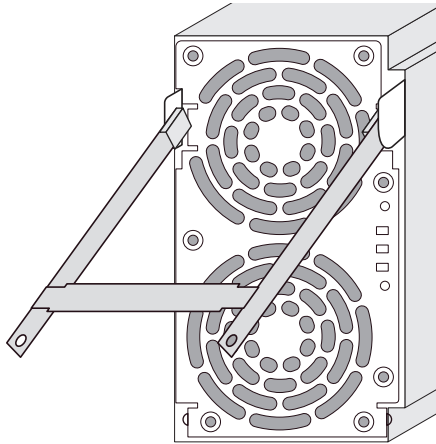
Figure 45: Extreme Networks 700/1200 W AC PSU with Locking Handle Open

EX_015

- 3 Carefully slide the Extreme Networks 700/1200 W AC PSU all the way into the power supply bay (see Figure 46).

**CAUTION**

Do not slam the Extreme Networks 700/1200 W AC PSU into the system switch backplane. Use the locking handle to secure the Extreme Networks 700/1200 W AC PSU into the system switch.

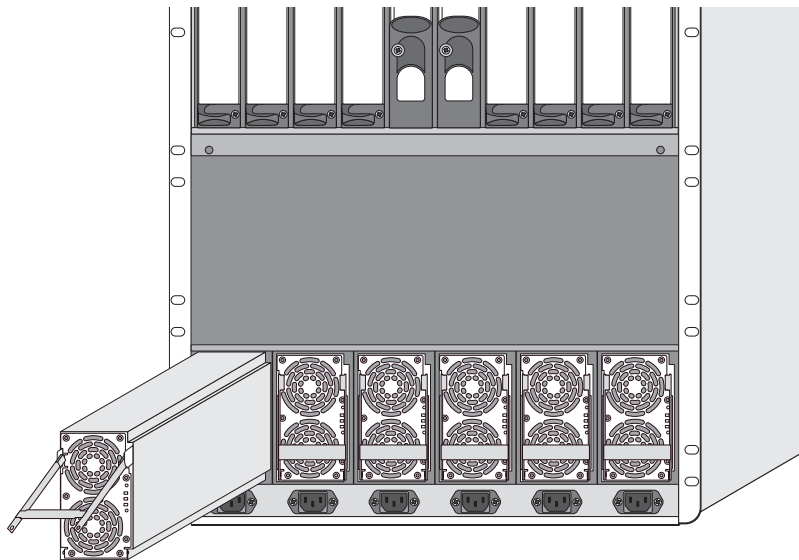
Figure 46: Inserting the 700/1200 W AC PSU into the Power Supply Bay

EX_011

- 4 Secure the Extreme Networks 700/1200 W AC PSU in the power supply bay by pushing down on the locking handle until it clicks into place.
- 5 Connect the AC power supply cord:
 - a If you are just replacing a power supply, you do not need to unplug the AC power cord.

- b If you are installing a new power supply into a previously unused slot on a switch with a retaining bracket, remove the power cord retaining bracket. (See [“Using the BlackDiamond12804 AC Power Cord Retainer Channel” on page 85](#) for information on removing the power cord retaining bracket and re-installing it.) Connect the AC power cord to the AC input on the front of the switch and to the wall outlet on the other end. Then, re-install the power cord retaining bracket.
- c If you are installing the power supply on a switch that does not have a power cord retaining bracket, connect the AC power cord to the AC input on the front of the switch and to the wall outlet on the other end. Then, install the power cord retaining bracket. (See [“Using the BlackDiamond12804 AC Power Cord Retainer Channel” on page 85](#) for information on removing the power cord retaining bracket and re-installing it.)

**NOTE**

Leave the ESD strap permanently connected to the switch, so that the strap is always available when you need to handle ESD-sensitive components.

To install additional Extreme Networks 700/1200 W AC PSUs, repeat steps 1 through 5.

Removing an Extreme Networks 700/1200 W AC PSU

**CAUTION**

The AC PSU may be hot to the touch; use thermal protective gloves when handling the 700/1200 W AC PSU during removal.

To remove an Extreme Networks 700/1200 W AC PSU:

- 1 Attach an ESD-preventive wrist strap to your wrist and connect the metal end to the ground receptacle that is located on the top-left corner of the switch front panel (if not already attached).
- 2 For the AC power cord:
 - a If you are going to use the same AC power cord for the new unit, you do not need to touch the power cord at all.
 - b If you are going to use a new AC power cord, remove the power cord retaining bracket. (See [“Using the BlackDiamond12804 AC Power Cord Retainer Channel” on page 85](#) for information on removing the power cord retaining bracket and re-installing it.) Connect the AC power cord to the AC input on the front of the switch and to the wall outlet on the other end. Then, re-install the power cord retaining bracket.
- 3 Lift the handle up on the Extreme Networks 700/1200 W AC PSU.
- 4 Pull on the handle of the Extreme Networks 700/1200 W AC PSU to remove it from the power supply bay.
- 5 Place both hands underneath the Extreme Networks 700/1200 W AC PSU to support the weight after it is pulled out from the switch.



**NOTE**

Leave the ESD strap permanently connected to the switch, so that the strap is always available when you need to handle ESD-sensitive components.

Front Panel LEDs

The front panel of the Extreme Networks 700/1200 W AC PSU provides status LEDs. [Table 18](#) describes the LED behavior on the front panel.

Table 18: Extreme Networks 700/1200 W AC PSU LEDs

PSU Condition	 Power Green	 Predictive Fail Amber	 Fail Amber
Power supply AC outputs working normally	On	Off	Off
AC input power present/standby output on	Blinking	Off	Off
Current limit on 48 VDC output	On	Off	Blinking
Predictive failure	On	Blinking	Off
No input power to this PSU only	Off	Off	On
No input power to any PSU	Off	Off	Off
Power supply failure	Off	Off	On

Power Supply Cords

Extreme Networks 700/1200 W AC PSU(s) come with both 110 V AC and 220 V AC power supply cords. The 110 V AC power supply cord allows for a maximum DC output power of 700 W. The 220V AC power supply cord allows for a maximum DC output power of 1200 W.



CAUTION

All power supply cords provided by Extreme Networks are designed for use in North America only. Power supply cords for use outside of North America are typically provided by a third-party distribution center and must meet the following requirements:

- Power supply cords must be agency certified for country of use.
- Power supply cords must contain an IEC 320 C13 connector on the end of the PSU.
- Power supply cords must contain an appropriately rated and approved wall plug applicable to the country of installation.
- Power supply cords must be less than 5 m long.
- Wire size must be a minimum of 16 AWG (1.0 mm²) copper-stranded.



WARNING!

Always be sure that the source outlet is properly grounded before plugging the AC power cord into the Extreme Networks 700/1200 W AC PSU.

Fuse

The Extreme Networks 700/1200 W AC PSU line and neutral legs are both fused. Power to the switch may still be live if the neutral fuse is open. This is not a field operator replaceable fuse. In the event of failure, immediately return the Extreme Networks 700/1200 W AC PSU for a complete replacement.



WARNING!

Field operators must not attempt to configure or replace fuses in Extreme Networks 700/1200 W AC PSUs! In the event of failure, immediately return the defective Extreme Networks 700/1200 W AC PSU for a complete replacement.



CAUTION

The 700/1200 W AC PSU does not have a switch for turning the unit on and off. Remove the plug from the electrical outlet to disconnect power to the 700/1200 W AC PSU. Make sure that this connection is easily accessible.

- *Make sure that the 700/1200 W AC PSU circuit is not overloaded. Use proper over-current protection, such as a circuit-breaker, to prevent over-current conditions.*

Using the BlackDiamond12804 AC Power Cord Retainer Channel

The AC power cord retaining channel for the BlackDiamond 12804 switch holds the power connectors in the power sockets and prevents accidental disconnection due to earthquakes, vibration, or other disturbances. A power cord retaining channel is provided with the BlackDiamond 12804 switch.

Pre-Installation Requirements

Connect all AC power cords before you install the power cord retainer channel.

You need the following tools and equipment to install or remove the BlackDiamond 12804 AC power cord retainer channel:

- ESD-preventive wrist strap
- #2 Phillips screwdriver

Installing the BlackDiamond 12804 AC Power Cord Retainer Channel

To install the BlackDiamond 12804 AC power cord retainer channel:

- 1 Attach the ESD-preventive wrist strap to your wrist and connect the metal end to the ground receptacle on the switch front panel.
- 2 Starting at the left, insert the plug of each AC power cord into the power connectors on the switch, and lift each installed power cord over the previous plug (see [Figure 47](#)).

Verify that all installed AC power cords are firmly plugged into the power connectors.

Figure 47: Installing and Routing the AC Power Cords

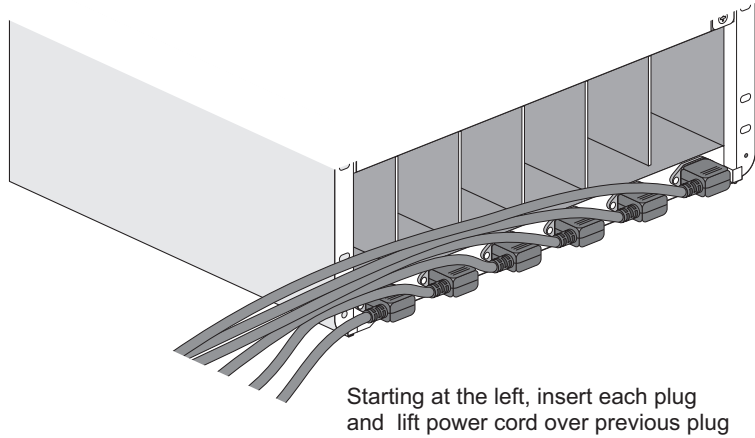

EX_138

- 3 Hold the AC power cord retainer channel in the position shown in [Figure 48](#).

Figure 48: BlackDiamond 12804 AC Power Cord Retainer

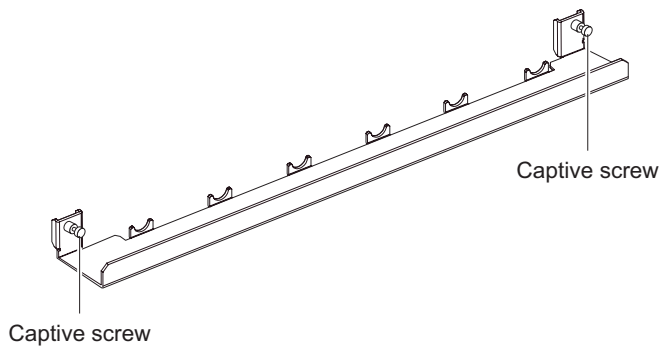

EX_141

- 4 Place the retainer channel against the switch as shown in [Figure 49](#). Tighten the captive screw at each end of the channel.

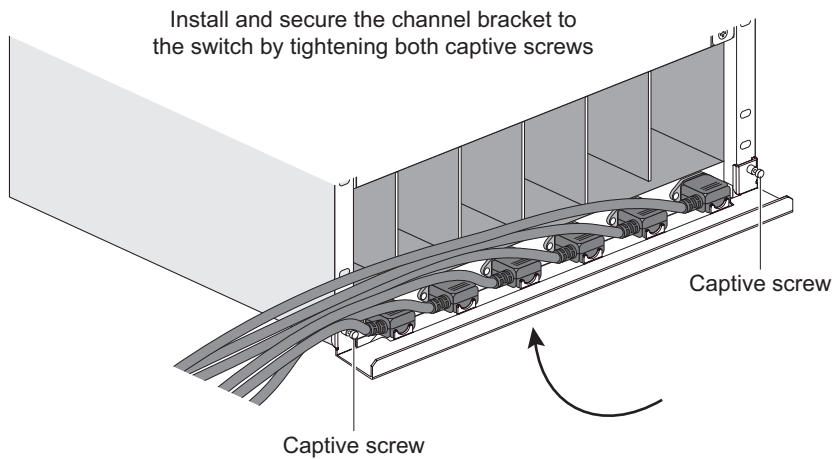
Figure 49: Securing the BlackDiamond 12804 AC Power Cord Retainer

- 5 Starting from the left, lay the first four power cords into the channel (see [Figure 50](#)).
- 6 Lay the last two power cords on top of the bottom four cords (see [Figure 50](#)).

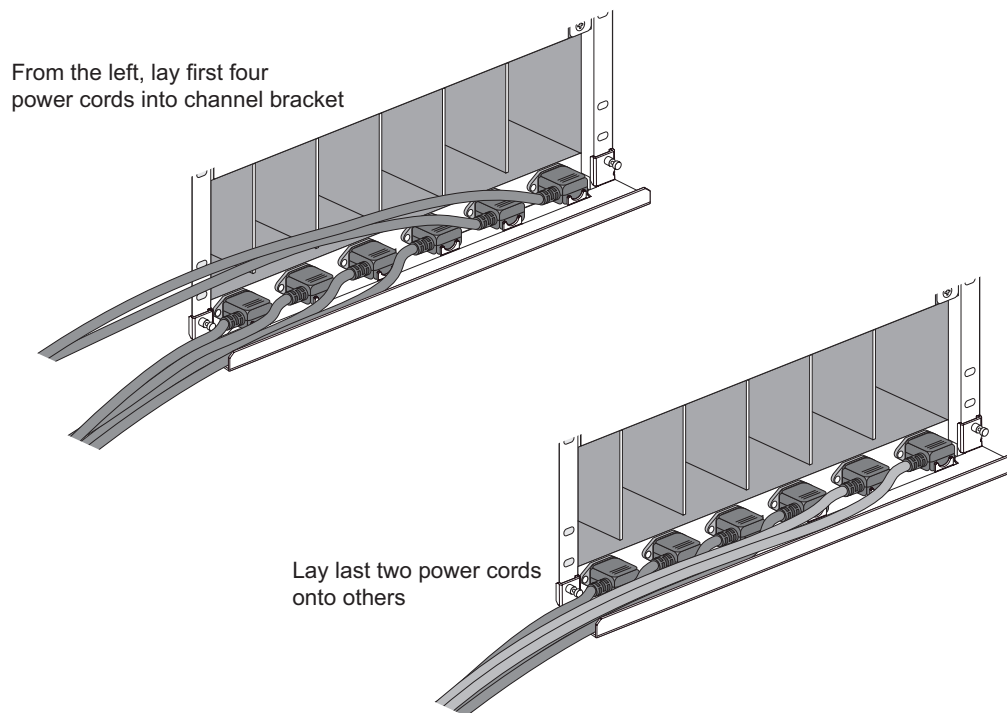
Figure 50: Routing the Power Cords in the Channel**NOTE**

Leave the ESD-preventive wrist strap permanently connected to the switch, so that the strap is always available when you need to handle ESD-sensitive components.

Removing the BlackDiamond 12804 AC Power Cord Retainer Channel

To remove the BlackDiamond 12804 AC power cord retainer channel:

- 1 Attach the ESD-preventive wrist strap to your wrist and connect the metal end to the ground receptacle on the switch front panel.
- 2 Using a #2 Phillips screwdriver, loosen the captive screw on each end of the power cord retainer channel.
- 3 Remove the power cord retainer channel from the switch.



NOTE

Leave the ESD-preventive wrist strap permanently connected to the switch, so that the strap is always available when you need to handle ESD-sensitive components.

Extreme Networks 325 W DC Power Supply

This section describes how to install the Extreme Networks® 325 W DC UL-listed accessory power supply unit (PSU), Model # 65022, in a BlackDiamond 12802 switch



NOTE

For centralized DC power connection, this product is intended to be installed in restricted access locations (dedicated equipment rooms, equipment closets, or the like) in accordance with Articles 110-16, 110-17, and 110-18 of the National Electric Code, ANSI/NFPA 70.



NOTE

The Extreme Networks 325 W DC PSU cannot be used in combination with any other Extreme Networks PSU.

The 325 W DC PSU should be connected to a DC power source using the Extreme Networks DC power input cable Model # 65025. This cable is shipped separately from the power supply.

Minimum Software Required

You must be running ExtremeWare XOS version 12.0 or later for the system to recognize the DC PSU.

Pre-Installation Requirements



WARNING!

Extreme Networks 325 W DC PSUs do not have switches for turning the unit on and off. Make sure that the DC circuit is de-energized before connecting or disconnecting the DC power cord and socket on the Extreme Networks 325 W DC PSU.

Wiring the 325 W DC PSU DC power cord to your facility DC source voltage must be performed by a qualified, licensed electrician.

Do not put your hand into an open power supply bay when a power supply is not present. Empty power supply bays require a cover plate at all times.

You need the following tools and equipment before installing or removing an Extreme Networks 325 W DC PSU:

- ESD-preventive wrist strap
- #2 Phillips screwdriver
- DC power supply cord, Model # 65052 (shipped separately from the PSU)
- Thermal protective gloves (required for removal)

Installing the DC Wiring



NOTE

All wiring methods involving the DC input cable assembly must be performed according to the relevant articles of the National Electrical Code.

The Extreme Networks 325 W DC PSU requires input DC cable Model # 65025 (see [Figure 51](#)). This cable is shipped separately from the power supply unit. You *must* use this cable with the Extreme Networks 325 W DC PSU.

Figure 51: Input DC Cable for the Extreme Networks 325 W DC PSU

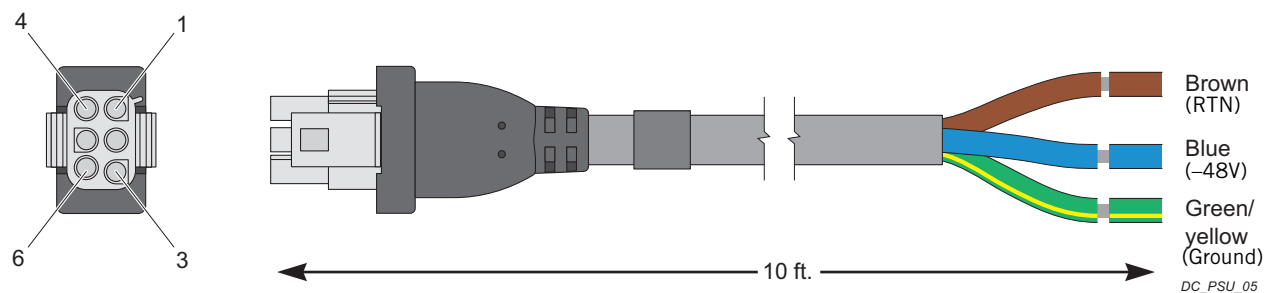

Each Extreme Networks 325 W DC PSU must be powered by a 15 A dedicated power source that delivers -40 to -72 VDC constant power to each 325 W DC PSU. Power distribution to the 325 W DC PSU shall be provided using the Model # 65025 -48 V DC cable. Power to the 325 W DC PSU can be from either a 15 A UL-approved overcurrent protection breaker or an SELV-approved power source in accordance with IEC 60950-1 utilizing 15 A overcurrent protection.

The input DC cable has an input connector on one end and precut wire on the other end that goes to the DC power source. The connector end has a locking mechanism that locks onto the DC PSU to prevent accidental removal of the input DC cable.

If necessary, use appropriate termination lugs for 14 AWG (1.3 mm²) copper-stranded wire on the precut ends of the cable to connect to the DC power source.

The blue termination (-48 V) connects to a 15 A overcurrent protection circuit device, and the brown (return) termination connects directly to the RTN bus of the DC power source. The green/yellow termination (ground) must connect to the same earth ground point as the switch.

Installing an Extreme Networks 325 W DC PSU



WARNING!

Make sure that the DC circuit is de-energized before you connect the DC power cord to the 325 W DC PSU or disconnect the DC power cord from the 325 W DC PSU.



WARNING!

Wiring the 325 W DC PSU DC power cord to your facility DC source voltage must be performed by a qualified, licensed electrician. After the DC power cord is connected to a permanent DC voltage source by a qualified, licensed electrician, you can remove, replace and maintain the 325 W DC PSU without further electrician assistance. However, make sure that the DC circuit is de-energized before connecting or disconnecting the DC power cord and socket on the Extreme Networks 325 W DC PSU.



CAUTION

The DC power cord must be properly connected to a DC main circuit breaker or fuse rated no greater than 15 A.



CAUTION

Provide proper connection and strain relief on the DC power cord in accordance with all local and national electrical codes.



CAUTION

Make sure that the Extreme Networks 325 W DC PSU circuit is not overloaded. Use proper over-current protection, such as a circuit breaker, to prevent over-current conditions.



NOTE

A minimum of two Extreme Networks 325 W DC PSUs are required to run a BlackDiamond 12802 switch.

To install an Extreme Networks 325 W DC PSU:

- 1 Attach an ESD-preventive wrist strap to your wrist and connect the metal end to the ground receptacle on the top right corner of the switch front panel.
- 2 Make sure that the Extreme Networks 325 W DC PSU is right side up (see [Figure 52](#)).

Figure 52: Extreme Networks 325 W DC PSU

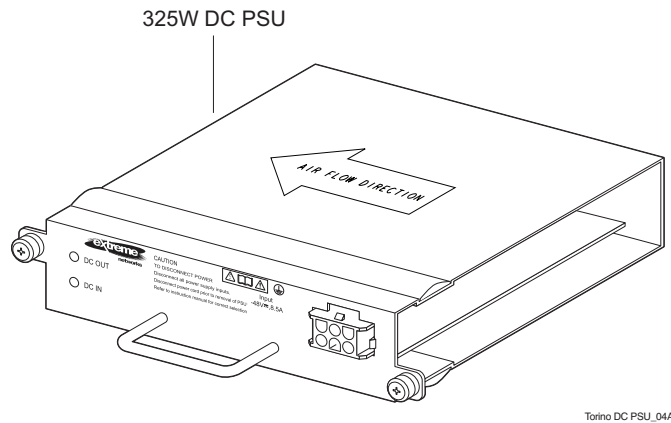

- 3 Carefully slide the PSU all the way into an open power supply bay (see [Figure 53](#)) until you hear a click.

Extreme Networks recommends that you populate the two left power supply bays before the two right power supply bays. Refer to [Table 19](#) for the recommended installation sequence.

Table 19: Recommended Installation Sequence (View from Rear of Chassis)

Left Power Supply Bays	Right Power Supply Bays
Installation # 1	Installation # 3 (If this bay is empty, a cover plate is required.)
Installation # 2	Installation # 4 (If this bay is empty, a cover plate is required.)



NOTE

A minimum of two Extreme Networks 325 W DC PSUs are required to run a BlackDiamond 12802 switch.



WARNING!

Do not put your hand into an open power supply bay when a power supply is not present. Empty power supply bays require a cover plate at all times.



CAUTION

Do not slam the Extreme Networks 325 W DC PSU into the system switch backplane.



CAUTION

To prevent an electrical hazard, make sure before you install the PSU in the power supply bay that the DC power cord is not connected to the PSU.

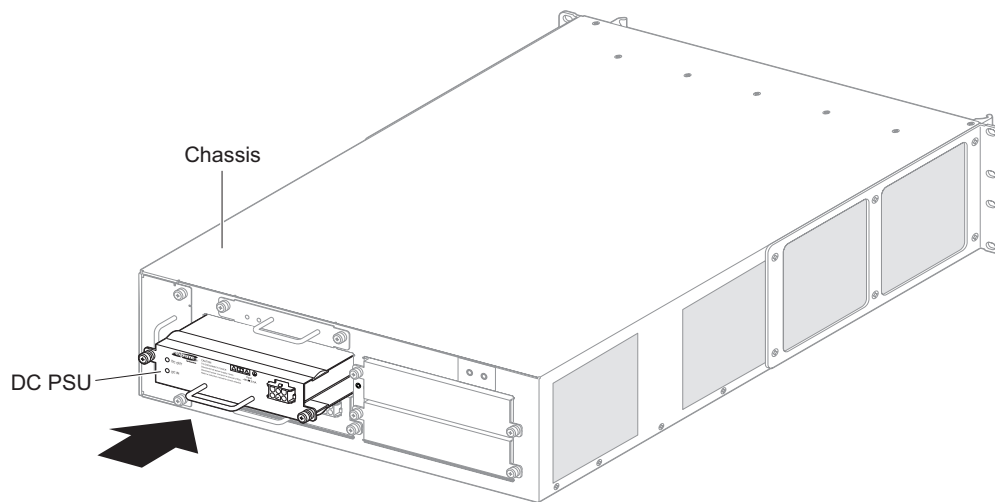
Figure 53: Installing the Extreme Networks 325 W DC PSU

Torino DC PSU_01A

- 4 To secure the 325 W DC PSU in the power supply bay, align and tightening the two captive screws on the PSU front panel. When you tighten the screws, work from left to right (see [Figure 54](#)).

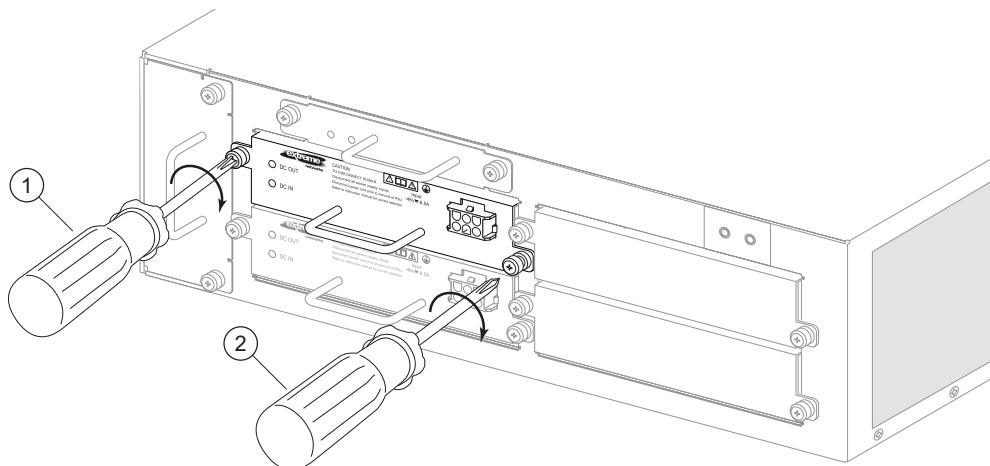
Figure 54: Securing the Extreme Networks 325 W DC PSU

Torino DC PSU_02A

- 5 Verify that the DC input cord was connected to a permanent DC voltage source by a qualified, licensed electrician.
- 6 Verify that the DC power is turned off at the source.
- 7 Plug the DC input cord into the DC input socket on the front of the 325 W DC PSU (see [Figure 55](#)). Verify that the input connector latch locks onto the connector on the DC PSU.

The pins must align properly for the cable to connect. Do not force the cable into the socket.

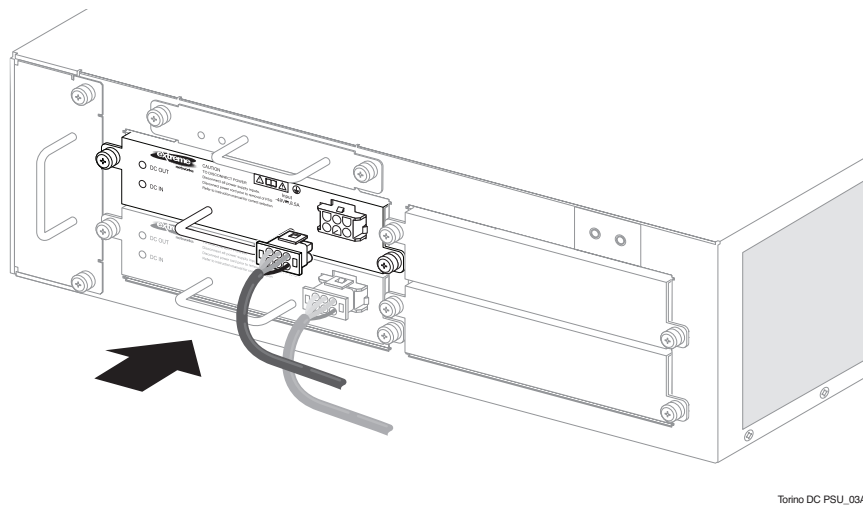
Figure 55: Connecting the DC Power Cord

Torino DC PSU_03A

**NOTE**

Leave the ESD strap permanently connected to the switch so that it is always available when you need to handle ESD-sensitive components.

Removing an Extreme Networks 325 W DC PSU

**CAUTION**

An operating 325 W DC PSU may be hot to the touch. Use thermal protective gloves when handling the 325 W DC PSU during removal.

**CAUTION**

To disconnect system power, disconnect ALL power supply units. Disconnect the power cord before you remove the PSU from the chassis.

To remove an Extreme Networks 325 W DC PSU:

- 1 Turn off the DC power at the source.
- 2 Attach an ESD-preventive wrist strap to your wrist and connect the metal end to the ground receptacle on the top right corner of the switch front panel.
- 3 Press down the catch on the DC input connector and disconnect the DC power cord from the front of the PSU.
- 4 Loosen the captive retaining screws on the PSU front panel.
- 5 Use the handle to pull the PSU from the chassis.

**NOTE**

Disconnection of the DC power cord from the DC source voltage must be performed by a qualified, licensed electrician.

**NOTE**

Leave the ESD strap permanently connected to the switch, so that the strap is always available when you need to handle ESD-sensitive components.

LEDs

The front panel of the Extreme Networks 325 W DC PSU provides status LEDs. [Table 20](#) describes the meanings of these LEDs.

Table 20: Extreme Networks 325 W DC PSU LEDs

PSU Condition	DC In LED Status	DC Out LED Status
No DC input power	Off	Off
No DC input power (receiving standby power from the chassis)	Amber	Off
DC input good (main outputs disabled)	Green	Off
DC input good, output fault	Green	Amber
DC input good, DC output good	Green	Green

**CAUTION**

Make sure that the 325 W DC PSU circuit is not overloaded. Use proper over-current protection, such as a circuit-breaker, to prevent over-current conditions.

Extreme Networks 325 W AC Power Supply

This section describes how to install the Extreme Networks 325 W AC UL-listed accessory power supply unit, Model # 65021, in the BlackDiamond 12802 switch.

**NOTE**

The Extreme Networks 325 W AC PSU cannot be used in combination with any other Extreme Networks PSU.

Pre-Installation Requirements

**WARNING!**

Extreme Networks 325 W AC PSUs do not have switches for turning the unit on and off. Remove the wall plug from the electrical outlet to disconnect the power to an Extreme Networks 325 W AC PSU. Make sure that this connection is easily accessible.

Do not connect the power supply to an electrical outlet when the power supply is outside of the chassis; doing so would expose a hazardous energy and poses a potential shock and fire hazard.

Do not put your hand into an open power supply bay when a power supply is not present. Empty power supply bays require a cover plate at all times.

You need the following tools and equipment to install or remove an Extreme Networks 325 W AC PSU:

- ESD-preventive wrist strap
- Power supply cord (110 V AC, 220 V AC, or applicable to country of use)
- #2 Phillips screwdriver
- Thermal protective gloves (required for removal)



NOTE

A minimum of two Extreme Networks 325 W AC PSU are required to run a BlackDiamond 12802 switch.

Installing an Extreme Networks 325 W AC PSU



CAUTION

Make sure that the Extreme Networks 325 W AC PSU circuit is not overloaded. Use proper over-current protection, such as a circuit-breaker, to prevent over-current conditions.

To install an Extreme Networks 325 W AC PSU:

- 1 Attach an ESD-preventive wrist strap to your wrist and connect the metal end to the ground receptacle on the top-right corner of the switch front panel.
- 2 Make sure that the Extreme Networks 325 W AC PSU is right side up (see [Figure 56](#)).

Figure 56: Extreme Networks 325 W AC PSU

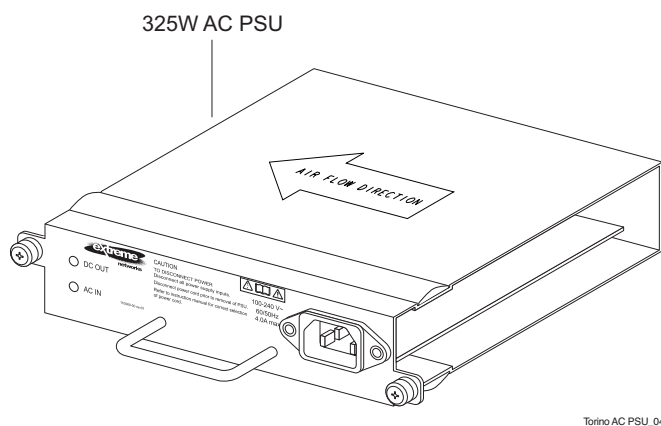

- 3 Carefully slide the Extreme Networks 325 W AC PSU all the way into an open power supply bay (see [Figure 57](#)) until you hear a click.

Extreme Networks recommends that you populate the two left power supply bays before the two right power supply bays. Refer to [Table 19](#) for the recommended installation sequence.

Table 21: Recommended Installation Sequence (View from Rear of Chassis)

Left Power Supply Bays	Right Power Supply Bays
Installation # 1	Installation # 3 (If empty, cover plate is required.)
Installation # 2	Installation # 4 (If empty, cover plate is required.)

**NOTE**

A minimum of two Extreme Networks 325 W AC PSUs are required to run a BlackDiamond 12802 switch.

**WARNING!**

Do not put your hand into an open power supply bay when a power supply is not present. Empty power supply bays require a cover plate at all times.

**CAUTION**

Do not slam the Extreme Networks 325 W AC PSU into the system backplane.

**CAUTION**

To prevent an electrical hazard, make sure before you install the PSU in the power supply bay that the AC power cord is not connected to the PSU.

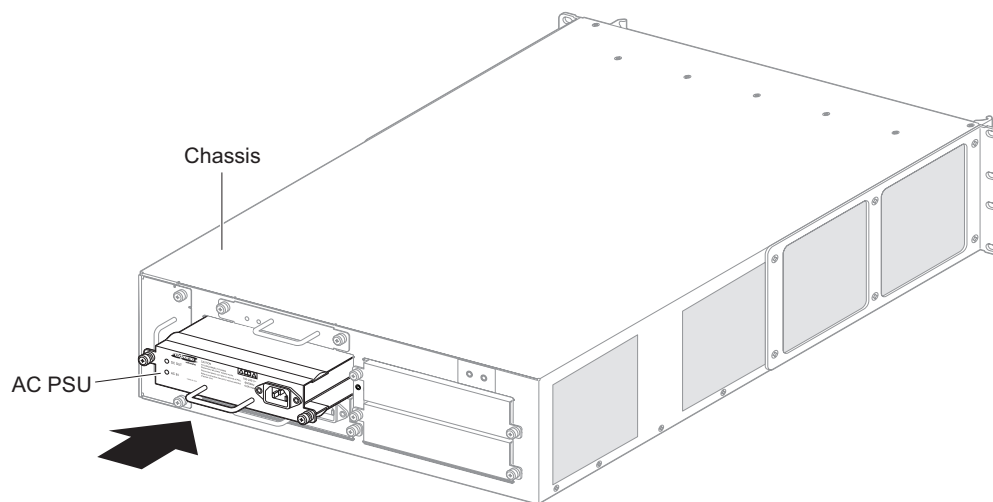
Figure 57: Installing a 325 W AC PSU

Torino AC PSU_01

- To secure the 325 W AC PSU in the power supply bay, align and tightening the two captive screws on the PSU front panel. As you tighten the screws, work from left to right (see [Figure 58](#)).

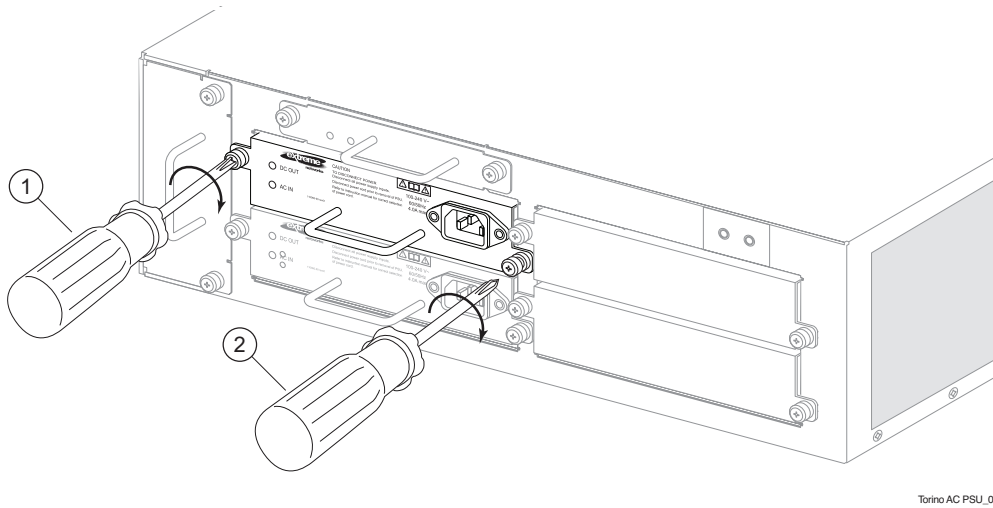
Figure 58: Securing the Extreme Networks 325 W AC PSU

Installing Retaining Brackets and Connecting Power

A power cord retaining bracket is shipped with each 325 W AC PSU. These brackets hold the power connectors in the power sockets and prevent accidental disconnection due to earthquakes, vibration, or other disturbances. Install the power cord retaining brackets before you connect the power cords.

To install the brackets and connect power to the switch:

- 1 Attach a power cord retaining bracket to each installed PSU as follows:
 - a Remove the two screws from the AC input socket on the PSU (see [Figure 59](#)).
 - b Using the screws and spacers provided with the bracket, attach the retaining bracket to the AC input socket as shown in [Figure 59](#).
 - c Tighten the screws to secure the power cord bracket.

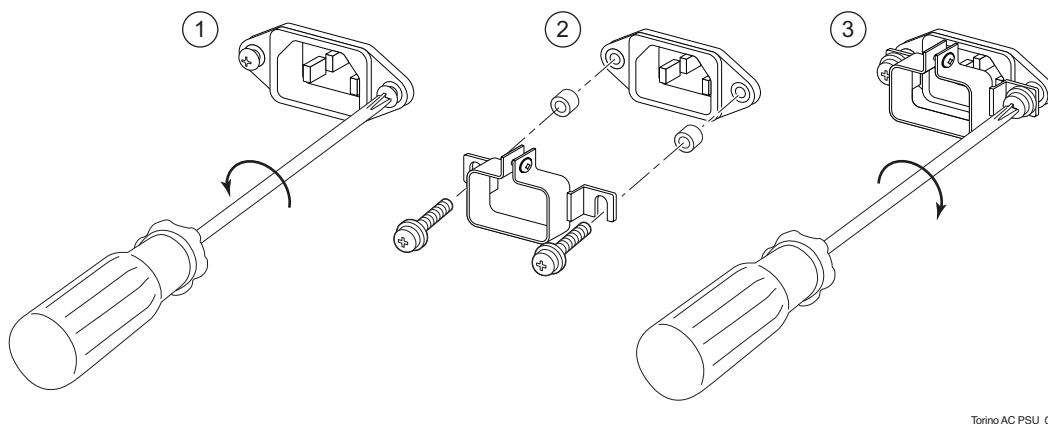
Figure 59: Attaching the AC Power Cord Retaining Bracket

**NOTE**

On each two vertically adjacent PSUs, attach the power cord bracket with the tightening screw on top and the lower power cord bracket with the tightening screw underneath, as shown in [Figure 60](#).

Figure 60: Power Cord Brackets on Two Adjacent Power Supplies

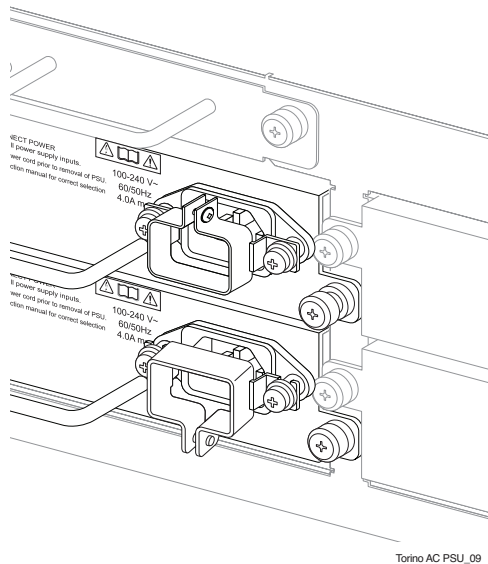

Torino AC PSU_09

- 2 Connect the AC power cord to the PSU as follows:
 - a Connect the AC power cord to the AC input on the front of the PSU (see [Figure 61](#)). If needed, loosen the middle screw of the power cord bracket to allow installation of the power cord.
 - b After the power cord is connected, tighten the middle screw of the bracket to secure the power cord in place (see [Figure 61](#)).

Figure 61: Connecting the AC Power Cord

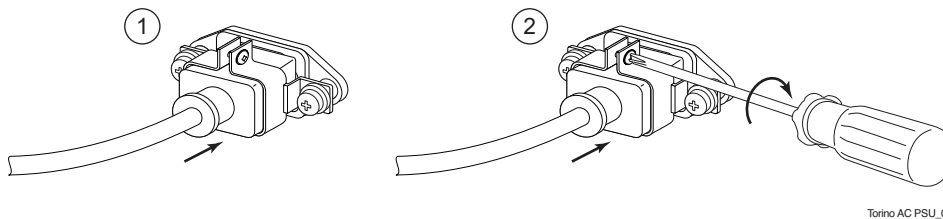

Torino AC PSU_08

- 3 Connect the opposite end of the AC power cord to the wall outlet.

**NOTE**

Leave the ESD strap permanently connected to the switch, so that the strap is always available when you need to handle ESD-sensitive components.

Removing an Extreme Networks 325 W AC PSU



CAUTION

An operating 325 W AC PSU may be hot to the touch; use thermal protective gloves when handling the 325 W AC PSU during removal.



CAUTION

To disconnect the system power, disconnect ALL power supply units. Disconnect the power cord before you remove the PSU from the chassis.

To remove an Extreme Networks 325 W AC PSU:

- 1 Attach an ESD-preventive wrist strap to your wrist and connect the metal end to the ground receptacle on the top right corner of the switch front panel.
- 2 Disconnect the AC power cord from the wall outlet.
- 3 Loosen the middle screw on the power cord bracket to allow removal of the power cord. After the screws are loosened, disconnect the AC power cord from the AC input on the front of the PSU.
- 4 Loosen the two captive screws that secure the PSU front panel to the chassis frame.
- 5 Use the handle to slide the PSU out of the chassis.



NOTE

Leave the ESD strap permanently connected to the switch, so that the strap is always available when you need to handle ESD-sensitive components.

Front Panel LEDs

The front panel of the Extreme Networks 325 W AC PSU provides status LEDs. [Table 22](#) describes the meanings of these LEDs.

Table 22: Extreme Networks 325 W AC PSU LEDs

PSU Condition	AC In LED Status	DC Out LED Status
No AC input power	Off	Off
No AC input power (receiving standby power from the chassis)	Amber	Off
AC input good (main outputs disabled)	Green	Off
AC input good, output fault	Green	Amber
AC input good, DC output good	Green	Green

Power Supply Cords

Each Extreme Networks 325 W AC PSU is shipped with a 110 V AC UL Listed power cord.

All power supply cords provided by Extreme Networks are designed for use in the United States and Canada only. Power supply cords for use outside of North America are typically provided by a third-party distribution center and must meet the following requirements:

- Power supply cords must be agency certified for country of use.
- Power supply cords must contain an IEC 320 C13 connector for insertion into the IEC 320 C14 receptacle on the PSU.
- Power supply cords must contain an appropriately rated and approved wall plug applicable to the country of installation.
- Power supply cords must be less than 5 m long.
- Wire size must be a minimum of 18 AWG (0.82 mm²) copper-stranded.



WARNING!

Make sure that the source outlet is properly grounded before plugging the AC power cord into the Extreme Networks 325 W AC PSU.

Fuse

The Extreme Networks 325 W AC PSU line is fused. This is not a field operator replaceable fuse. In the event of failure, immediately return the Extreme Networks 325 W AC PSU for a complete replacement.



WARNING!

Field operators must not attempt to configure or replace fuses in Extreme Networks 325 W AC PSUs! In the event of failure, immediately return the defective Extreme Networks 325 W AC PSU for a complete replacement.

7

Installing Modules and Connecting Cables

This chapter provides important safety information and correct installation procedures for the MSMs and I/O modules in the BlackDiamond 12800 series switches. All module types are hot-swappable.

The chapter includes the following sections:

- [Module Slot Assignments on page 101](#)
- [Distinguishing a BlackDiamond 12800 Series MSM from an I/O Module on page 102](#)
- [Installing a BlackDiamond 12800 Series Module on page 102](#)
- [Making Network Interface Cable Connections on page 105](#)
- [Installing a Backup MSM on page 105](#)
- [Verifying the Module Installation on page 106](#)
- [Removing a BlackDiamond 12800 Series Module on page 106](#)
- [BlackDiamond Series Blank Front Panels on page 108](#)



NOTE

Read the information in this chapter thoroughly before you attempt to install or remove BlackDiamond 12800 series MSM or I/O module.



CAUTION

Do not attempt to mix modules across Extreme Networks product lines. Blackdiamond 12800 series modules are for use only in a BlackDiamond 12804 or 12802 switch. When a BlackDiamond switch is in use, ExtremeXOS software will not recognize a module from a different product line.

Module Slot Assignments

The specific slot locations for I/O modules and MSMs in the chassis are as follows:

- BlackDiamond 12804 switch
 - Slots 1, 2, 5, and 6 must have I/O modules.
 - slots 3/A and 4/B must have MSMs.
- BlackDiamond 12802 switch
 - Slots 1 and 2 (top and bottom) must have I/O modules.
 - Slot MSM (middle) must have an MSM.

Chassis slots will only operate their designated module type.

In the BlackDiamond 12802 switch, the slot for the MSM is labeled MSM. The ExtremeXOS software refers to this MSM as MSM-A in all related displays and command output.

Distinguishing a BlackDiamond 12800 Series MSM from an I/O Module

One quick way to distinguish a BlackDiamond 12800 MSM from an I/O module is by the color of the release latch located on each injector/ejector release latch. Orange injector/ejector latches indicate that the module is a BlackDiamond MSM, and green injector/ejector latches indicate that the module is a BlackDiamond I/O module (see [Figure 62](#)).

Figure 62: Injector/Ejector Release Latch Colors on I/O Modules and MSMs

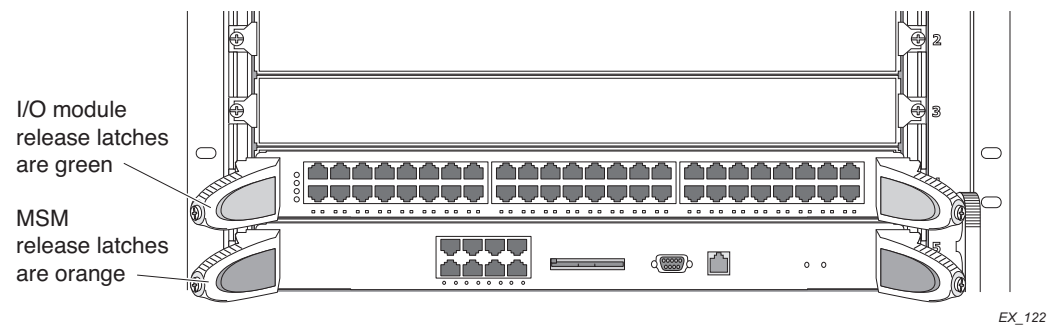

Installing a BlackDiamond 12800 Series Module

You need the following tools and equipment to install a BlackDiamond 12800 series MSM or I/O module:

- ESD-preventive wrist strap
- #2 Phillips screwdriver
- Appropriate type of cable for the module if you are installing an I/O module



CAUTION

The module series number must be the same as the switch series number. For example, install BlackDiamond 1200 series modules only in a BlackDiamond 12800 series switch.

To install a module in a BlackDiamond 12800 series switch:

- 1 Attach the ESD-preventive wrist strap to your wrist and connect the metal end to the ground receptacle on the chassis.
On a BlackDiamond 12804 chassis, the ground receptacle is at the top left corner.
On a BlackDiamond 12802 chassis, the ground receptacle is at the top right corner.
- 2 Select a slot for the module. (See “[Module Slot Assignments](#)” on page 101.)
- 3 Remove a blank front panel from a chassis slot, if applicable.

**NOTE**

Any unoccupied module slot in the chassis should have a blank faceplate installed to ensure satisfactory protection from EMI and to maintain adequate airflow through the chassis.

- 4 Remove the module from the antistatic packaging as follows:
 - a Place the antistatic bag containing the module on a flat ESD surface that is clear of any debris.
 - b Break the quality seal, the ESD warning seal, and the Read Installation Note seal.
 - c Open the antistatic bag and firmly grasp the rail of the module.
 - d Pull the antistatic bag off while holding the rail of the module.

**CAUTION**

To prevent ESD damage, hold the module by the metal rail and front panel only. Never touch the components on the PCB or pins on any of the connectors.

- 5 Verify that the module injector/ejector handles are open ([Figure 63](#)).

Figure 63: Injector/Ejector Handles in an Open Position

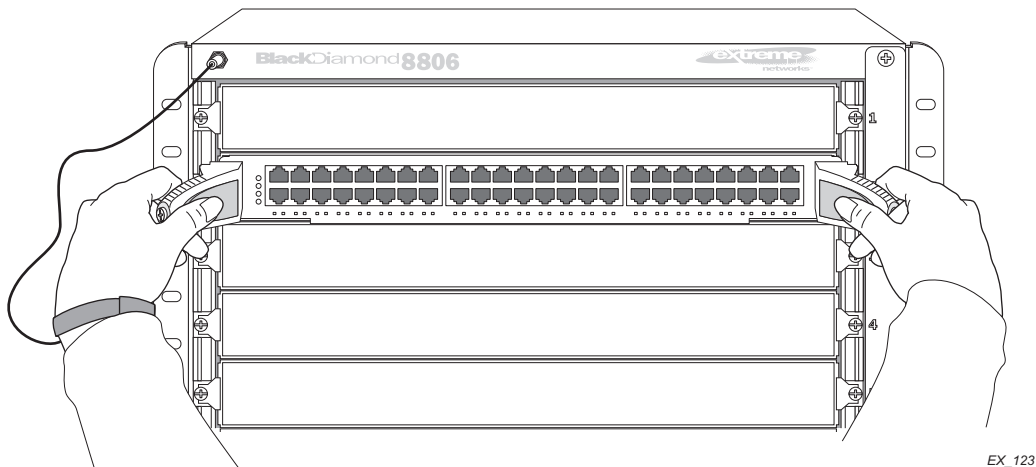

EX_123

- 6 Keep the injector/ejector handles in the open position as you slide the module into the chassis slot.

**CAUTION**

Do not slide the module into the open chassis slot if the injector/ejector handles are in the latched position.

- 7 Use both hands to latch the injector/ejector handles, by simultaneously pushing both handles toward the center of the module as shown in [Figure 64](#).

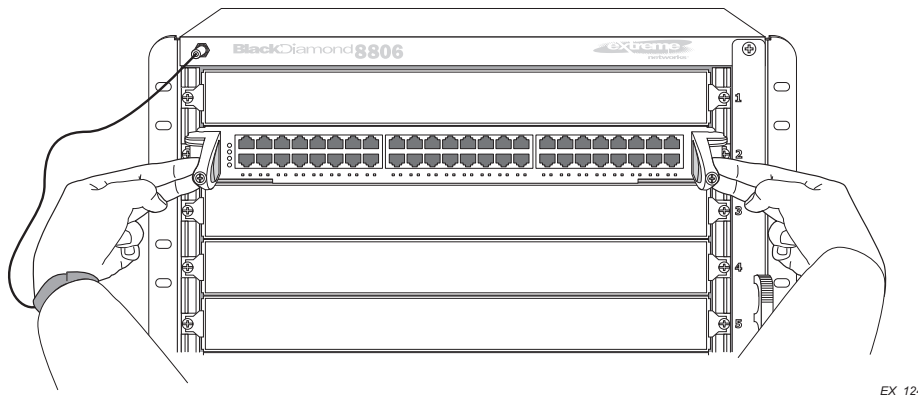
Figure 64: Injector/Ejector Handles in the Latched Position

EX_124

**CAUTION**

There are two styles of ejector/injector handles on the BlackDiamond 12800 series modules. Pay careful attention to the instructions in the next step.

- 8 Using a #2 Phillips screwdriver, lock the module into place in one of the following ways (Figure 65):
 - If the captive screw on each handle has a yellow band around the head of the screw, turn the screw on each injector/ejector handle clockwise and *completely* down. When the screw is completely tightened, the yellow band around the captive screw is completely hidden.

**CAUTION**

Be careful to avoid over-torquing and stripping the screw heads.

- If the captive screw on each handle has a red line on the head (see Figure 66), turn each captive screw one-quarter turn (90 degrees) clockwise. When the module is correctly locked, the red line on the captive screw in each injector/ejector handle is in a vertical position.

**CAUTION**

Be sure to turn each captive screw only 90 degrees or one-quarter turn clockwise. Tightening the captive screws beyond 90 degrees will damage the injector/ejector handles on the modules.

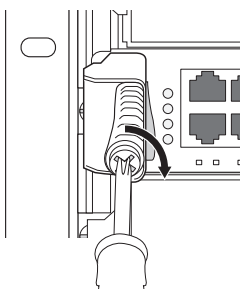
Figure 65: Locking the Module into Place

EX_125

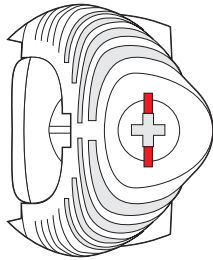
Figure 66: Captive Screw with Red Line

EX_162

- 9 Store the module packaging for future use.

**NOTE**

Leave the ESD-preventive wrist strap permanently connected to the chassis so that the strap is always available when you need to handle ESD-sensitive components.

Making Network Interface Cable Connections

Use the appropriate type of cable to connect the ports of your switch to another switch or router.

Working carefully, one port at a time:

- 1 Verify that you have identified the correct cable for the port.
- 2 Use an alcohol wipe or other appropriate cleaning agent to clean the cable connectors; make sure they are free of dust, oil, and other contaminants.
- 3 If you are using optical fiber cable, align the transmit (Tx) and receive (Rx) connectors with the correct corresponding connectors on the switch or the I/O module.
- 4 Press the cable connectors into their mating connectors on the switch or I/O module until the cable connector is firmly seated.
- 5 Repeat steps 1 through 4 for the remaining cables on this or other switches or I/O modules.
- 6 Dress and secure the cable bundle to provide appropriate strain relief and protection against bends and kinks.

Installing a Backup MSM

If you install a backup MSM, use the `synchronize` command to replicate all saved images and configurations from the primary MSM to the backup MSM.

You are not prompted to synchronize the images and the configurations from the primary to the backup. If not synchronized, the backup uses its image and the primary configuration. This image/configuration mismatch will likely cause the switch to operate differently after failover.

**CAUTION**

Depending on the size and complexity of your network, you should install and configure a backup MSM when network disruption will be minimal. You may need to reboot your switch after you use the synchronize command.

Verifying the Module Installation

After you install a module, verify that it is working correctly by checking the LEDs on the front panel of the module. [Table 23](#) shows normal LED operation for correctly installed MSMs and I/O modules.

Use the command line interface (CLI) `show slot <slot number>` command to display slot-specific information about the newly installed module.

Table 23: Module LED activity for normal operation

MSM		I/O Module	
LED	State/Meaning	LED	State/Meaning
SYS	Green blinking	STATUS	Green blinking
MSTR	Green: MSM is primary Amber: MSM is backup	DIAG	Off
ENV	Green	Port status (per port)	Green Amber blinking
Link/Activity	Green: Link is up. Amber: Packet activity is occurring.		

For more information about LED activity, see the descriptions in [Chapter 3](#).

Displaying Slot Status Information

Assuming the module has no problems, the command `show slot <slot>` (where `<slot>` is the number of the slot where you installed the module) displays information about the module including: general information about the module (name, serial number, part number), the state of the module (power down, operational, mismatch between the slot configuration and the module in the slot), and the number of ports on the module.

For more information about slot status information, see the *ExtremeXOS 12.0 Concepts Guide* and the *ExtremeXOS 12.0 Command Reference Guide*.

Removing a BlackDiamond 12800 Series Module

**CAUTION**

There are two styles of ejector/injector handles on the BlackDiamond 12800 series modules. Pay careful attention to the instructions in [step 2](#).

This section describes how to remove modules from a BlackDiamond 12800 series switch. BlackDiamond modules are hot-swappable. You do not need to power the system off to remove a module.

You will need the following tools and equipment to remove a BlackDiamond MSM or I/O module:

- ESD-preventive wrist strap
- #2 Phillips screwdriver

To remove a BlackDiamond 12800 series module:

- 1 Attach the ESD-preventive wrist strap to your wrist and connect the metal end to the ground receptacle on the chassis.
 - On a BlackDiamond 12804 series chassis, the ground receptacle is at the top left corner.
 - On a BlackDiamond 12802 chassis, the ground receptacle is at the top right corner.
- 2 Unlock the module in one of the following ways:
 - On a module *without* red lines on the screwheads, turn each captive screw counter-clockwise (Figure 67). Verify that the yellow band around the captive screw head of each injector/ejector handle is completely visible (Figure 67). This position ensures that the module is unlocked.
 - On a module *with* red lines on the screwheads, turn each captive screw counter-clockwise one-quarter turn (90 degrees) (Figure 67). Verify that the red line on each captive screw is in a horizontal position (Figure 68). This position ensures that the MSM or I/O module is unlocked.



CAUTION

Be sure to turn each captive screw only 90 degrees or one-quarter turn counter-clockwise. Loosening the captive screws beyond 90 degrees will damage the injector/ejector handles on the module.

Figure 67: Unlocking a Module

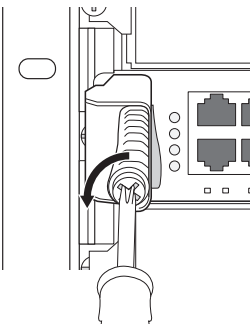

EX_125a

Figure 68: Indications that the Module is Unlocked

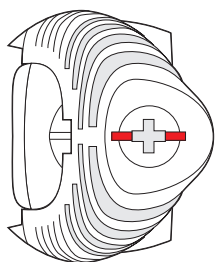

EX_161

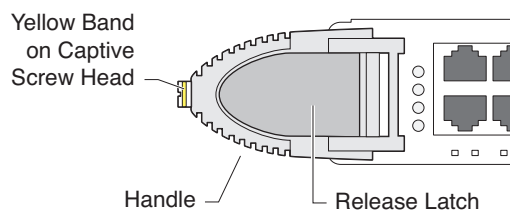

EX_173

- Squeeze the release latch on each injector/ejector handle and rotate both handles outward to disconnect the module from the chassis backplane (see [Figure 68](#)).

**CAUTION**

To prevent ESD damage, hold the module by the metal panel edges only. Never touch the components on the PCB or the pins on any of the connectors.

- Slide the module out of the chassis slot.
- Place the module into the anti-static bag to protect it from potential ESD damage. The bag will also prevent dust from collecting on the module connectors.
- If you are not going to install a replacement module, install a blank front panel. To install a replacement module, follow the installation procedure starting [on page 102](#).

**NOTE**

Leave the ESD-preventive wrist strap permanently connected to the chassis so that it is always available when you need to touch ESD-sensitive components.

BlackDiamond Series Blank Front Panels

BlackDiamond switches are shipped with blank front panels installed over one or more chassis slots. You can remove or install a blank front panel at any time without disrupting network services. Complete the action of installing a blank front panel in a reasonable time-frame to avoid disruption to adequate airflow.

**CAUTION**

All unoccupied slots in a BlackDiamond 12800 series switch must have blank front panels correctly installed to ensure conformance to FCC requirements as well as to maintain adequate airflow through the switch.

You need the following tools and equipment to install or remove a blank front panel:

- ESD-preventive wrist strap
- #2 Phillips screwdriver

Installing a Blank Front Panel

To install the blank front panel:

- Attach the ESD-preventive wrist strap to your wrist and connect the metal end to the ground receptacle on the BlackDiamond chassis.
On a BlackDiamond 12804 chassis, the ground receptacle is at the top left corner.
On a BlackDiamond 12802 chassis, the ground receptacle is at the top right corner.
- Align the blank front panel over the open slot on the chassis (see [Figure 69](#)).
Make sure that the EMI gasket is on the top of the panel and the stenciled part number is right side up.

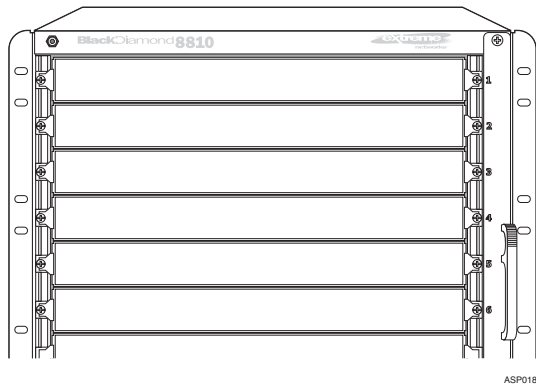
Figure 69: Blank Front Panels in BlackDiamond Series Chassis

- 3 Use a #2 Phillips screwdriver to tighten the captive screws at each end of the blank front panel.

**NOTE**

Tighten the screws of each installed blank front panel before inserting additional modules or blank front panels. Otherwise, you might unseat modules or blank front panels that you have not secured.

**NOTE**

Leave the ESD-preventive wrist strap permanently connected to the chassis so that it is always available when you need to touch ESD-sensitive components.

Removing a Blank Front Panel

To remove a BlackDiamond blank front panel:

- 1 Attach the ESD-preventive wrist strap to your wrist and connect the metal end to the ground receptacle on the switch front panel.
On a BlackDiamond 12804 series chassis, the ground receptacle is at the top left corner.
On a BlackDiamond 12802 chassis, the ground receptacle is at the top right corner.
- 2 Loosen the captive screw at each end of the blank front panel, using a #2 Phillips screwdriver (see [Figure 70](#)).

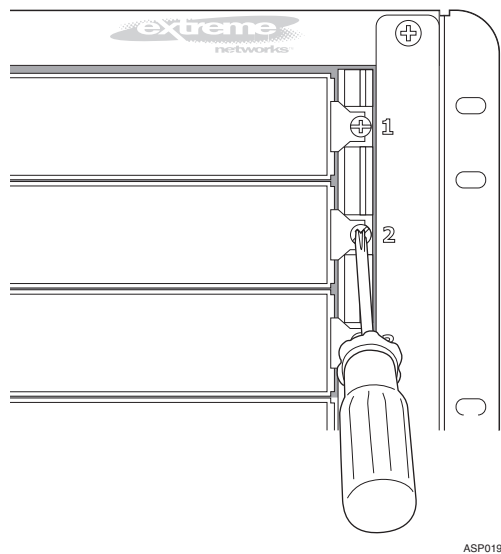
Figure 70: Captive Screw on a BlackDiamond 12800 Blank Front Panel

- 3 Remove the blank front panel from the intended slot on the BlackDiamond switch (see [Figure 71](#)).

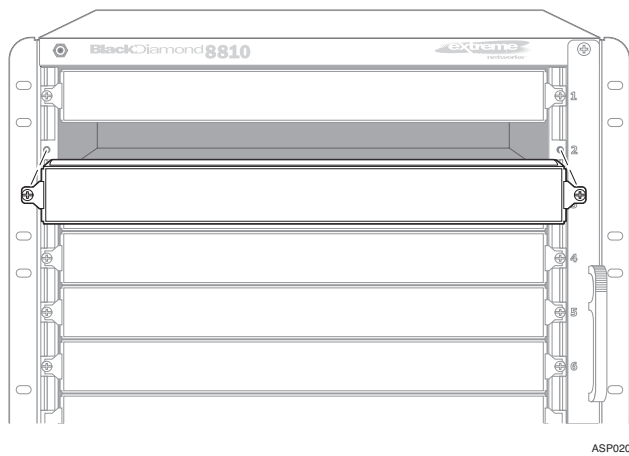
Figure 71: Removing a Blank Front Panel from a BlackDiamond 12800 Series Switch

- 4 Install an I/O module or MSM in the open slot as described in [“Installing a BlackDiamond 12800 Series Module”](#) on page 102 or [“Installing a Backup MSM”](#) on page 105.

**NOTE**

Leave the ESD-preventive wrist strap permanently connected to the switch, so that the strap is always available when you need to handle ESD-sensitive components.

Installing or Removing an External Compact Flash Memory Card

You do not need to power off the system or remove the MSM from the chassis to install or remove an external compact flash memory card.

You need an ESD-preventive wrist strap to install a compact flash memory card.

To install the memory card:

- 1 Attach the ESD-preventive wrist strap to your wrist and connect the metal end to the ground receptacle on the chassis front panel.
- 2 Locate the compact flash slot on the MSM, as shown in [Figure 72](#).

Figure 72: Typical Compact Flash Slot Location

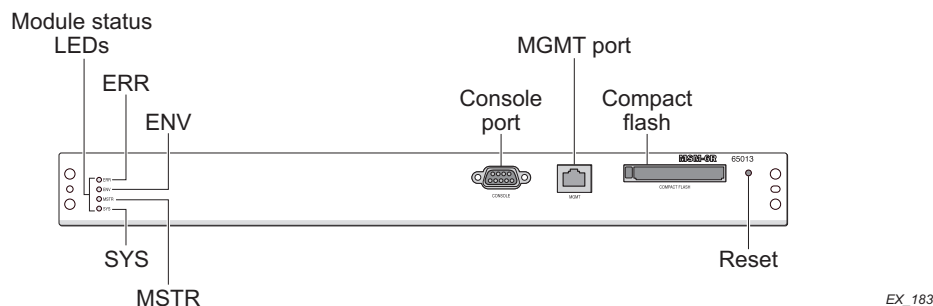

- 3 Hold the memory card between your thumb and forefinger, with the ridge facing toward the bottom of the chassis.
- 4 Slide the card into the compact flash slot until you feel resistance.; a portion of the card will protrude from the slot.
- 5 Carefully push the card until it is seated into the slot. The card should be fully inserted, or seated, inside the slot.
- 6 To verify that the card is fully seated, use the `show memorycard` command.

To remove the external compact flash memory card:

- 1 Use the `eject memorycard` command to ensure that you will not lose any data when you remove the card.

After you use the `eject memorycard` command, you can physically remove the card from the external compact flash slot on the MSM. For more information about the `eject memorycard` command, see the *ExtremeXOS 12.0 Concepts Guide*.

- 2 Attach the ESD-preventive wrist strap to your wrist and connect the metal end of the strap to the ground receptacle on the chassis front panel.
- 3 Locate the black release pin just above the compact flash slot.
- 4 Press the release pin until the card releases from the slot.
The card releases to an intermediate position; the card remains partially inserted but is no longer seated in the slot.
- 5 Remove the card completely and place it in a safe location.

3

BlackDiamond Maintenance Procedures

8

Replacing BlackDiamond 12800 Series Chassis Components

This chapter provides important safety information and instructions on how to remove and replace the PSU/fan controller and the fan tray in a BlackDiamond 12800 series switch.

BlackDiamond 12800 series switches have one fan tray. The BlackDiamond 12804 switch contains two PSU/fan controllers, and the BlackDiamond 12802 switch has one PSU-fan controller.

This chapter includes the following sections:

- [Safety Information on page 115](#)
- [Replacing a BlackDiamond 12804 PSU/Fan Controller on page 115](#)
- [Replacing a BlackDiamond 12802 PSU/Fan Controller on page 118](#)
- [Replacing a BlackDiamond 12804 Fan Tray on page 119](#)
- [Replacing the BlackDiamond 12802 Fan Tray on page 121](#)

Safety Information

Service to all BlackDiamond equipment should be performed by trained service personnel only. Read all important safety information before installation or removal. See [Appendix A](#) for additional information regarding regulatory compliance certifications applicable to a BlackDiamond PSU/fan controller.

Thoroughly review the information about power supplies in [Chapter 4](#) before working with the PSU/fan controller unit.

Replacing a BlackDiamond 12804 PSU/Fan Controller

The BlackDiamond 12804 switch has two PSU/fan controllers behind an access panel on the rear of the switch chassis.



NOTE

If your system is running ExtremeXOS version 11.2.1.3 or later, you can hot swap the PSU/fan controller unit. Refer to the ExtremeXOS 12.0 Concepts Guide for complete information about upgrading software.

Pre-Installation Requirements

Make sure that you have access to the back of the switch. You need the following tools and equipment to replace a BlackDiamond 12804 PSU/fan controller:

- ESD-preventive wrist strap
- #1 Phillips screwdriver
- #2 Phillips screwdriver
- Replacement BlackDiamond 12804 PSU/fan controller

Removing a BlackDiamond 12804 PSU/Fan Controller

To remove a PSU/fan controller from the BlackDiamond 12804 switch:

- 1 Attach the ESD-preventive wrist strap to your wrist and connect the metal end to the ground receptacle on the front top-left corner of the switch.
- 2 Locate the eight captive screws on the PSU/fan controller access cover at the back of the BlackDiamond 12804 switch (see [Figure 73](#)).

Figure 73: Removing the PSU/Fan Controller Access Cover

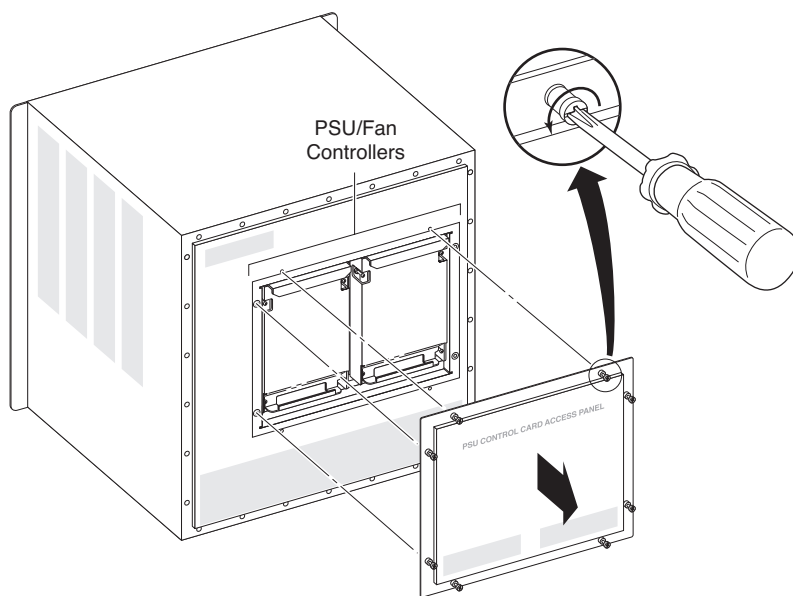

BD_169

- 3 Using a #2 Phillips screwdriver, loosen all eight captive screws on the PSU/fan controller access cover (see [Figure 73](#)).
- 4 Pull the access cover away from the back of the switch.
The PSU/fan controllers are visible in the controller recess.
- 5 Locate the four captive screws on the PSU/fan controller you are replacing (see [Figure 74](#)).

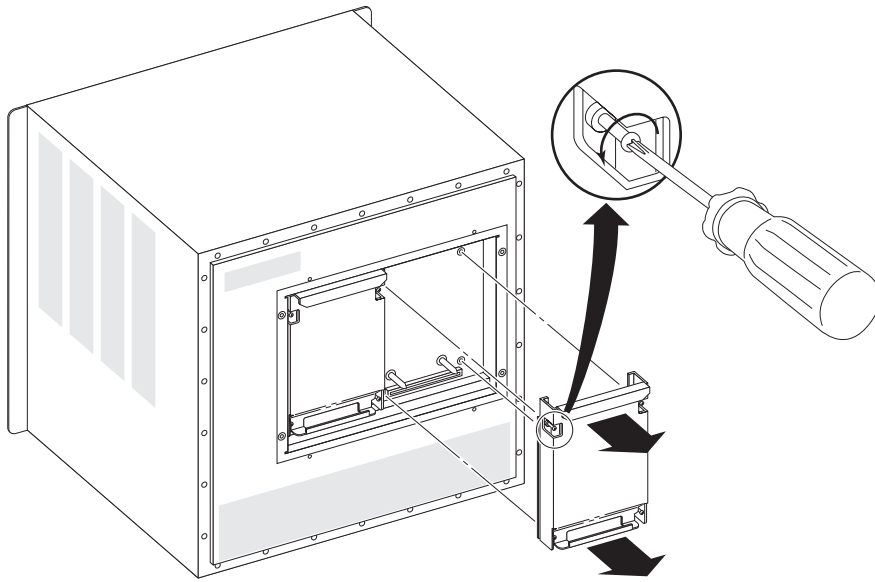
Figure 74: Removing the BlackDiamond 12804 PSU/Fan Controller

BD_170

- 6 Using a #1 Phillips screwdriver, loosen all four captive screws on the PSU/fan controller (see [Figure 74](#)).
- 7 Pull equally on the upper and lower handles of the PSU/fan controller to disconnect the controller connector.

Leave the ESD-preventive wrist strap permanently connected to the switch, so that the strap is always available when you need to handle ESD-sensitive components.

Installing a Replacement BlackDiamond 12804 PSU/Fan Controller

To install a replacement PSU/fan controller in the BlackDiamond 12804 switch:

- 1 Attach the ESD-preventive wrist strap to your wrist and connect the metal end to the ground receptacle on the front top-left corner of the switch.
- 2 Align the guide pins in the empty controller recess with the holes on the replacement PSU/fan controller.
- 3 Push the replacement BlackDiamond 12804 PSU/fan controller into the empty controller recess until the four captive screws on the replacement controller are in alignment.
- 4 Using a #1 Phillips screwdriver, tighten all four captive screws on the replacement controller.
- 5 Align the guide pins on the access cover with the holes at the edges of the controller recess.
- 6 Push the access cover over the controller recess until the eight captive screws on the access cover are in alignment.
- 7 Using a #2 Phillips screwdriver, tighten all eight captive screws on the access cover.

Leave the ESD-preventive wrist strap permanently connected to the switch, so that the strap is always available when you need to handle ESD-sensitive components.

Replacing a BlackDiamond 12802 PSU/Fan Controller

The BlackDiamond 12802 switch has one PSU/fan controller, accessible from the back of the switch.

Removing the PSU/fan controller causes the switch to stop operation until the controller is replaced. Be sure to have the replacement controller available before you start the replacement process.

Pre-installation Requirements

Make sure that you have access to the back of the BlackDiamond 12802 switch.

Power off the BlackDiamond 12802 switch before you begin to replace the PSU/fan controller.

To replace a BlackDiamond PSU/fan controller, you need the following tools and equipment:

- ESD-preventive wrist strap
- #2 Phillips screwdriver
- Replacement BlackDiamond 12802 PSU/fan controller

Removing a BlackDiamond 12802 PSU/Fan Controller

To remove a BlackDiamond 12802 PSU/fan controller:

- 1 Attach the ESD-preventive wrist strap to your wrist and connect the metal end to the ground receptacle on the front top-right corner of the switch.
- 2 Power off the switch.
- 3 Using a #2 Phillips screwdriver, loosen the captive retaining screws until they are free of the switch back panel.
- 4 Use the handle to pull the controller out of the BlackDiamond 12802 chassis ([Figure 74](#)). Set the controller on an ESD-preventive surface.

Figure 75: Removing a BlackDiamond 12802 PSU/Fan Controller

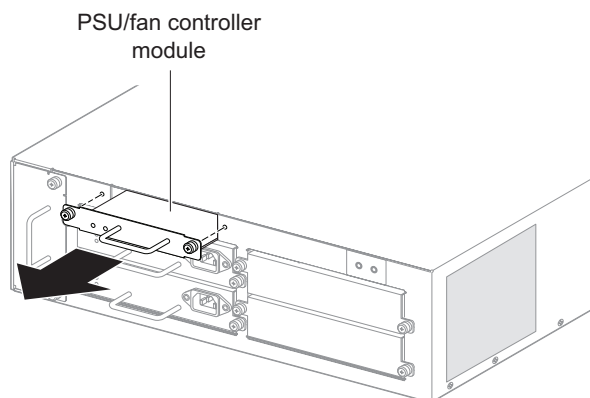

BD_144

Installing the Replacement PSU/Fan Controller

To install the replacement controller:

- 1 Remove the replacement PSU/fan controller from its antistatic packaging.
- 2 Insert the replacement controller into the controller slot on the BlackDiamond 12802 chassis (Figure 76).
- 3 Align and tighten the captive retaining screws.

Figure 76: Installing a PSU/Fan Controller

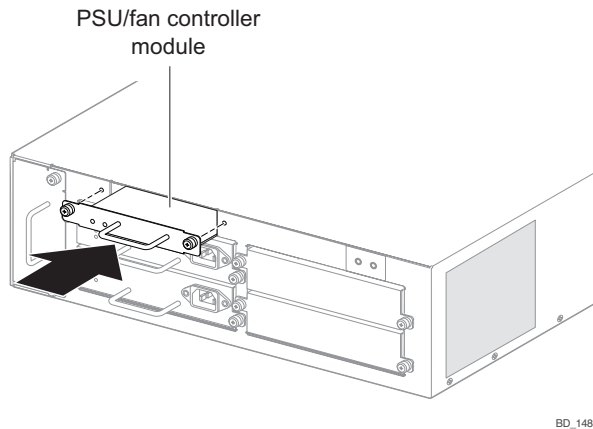

- 4 Power on the switch.

Leave the ESD-preventive wrist strap permanently connected to the switch so that it will always be available when you need to handle ESD-sensitive components.

Replacing a BlackDiamond 12804 Fan Tray

The BlackDiamond 12804 switch has one fan tray that is accessible from the front of the switch.



CAUTION

Removing the fan tray for more than a few minutes may result in overheating and possible damage to the system. Thermal sensors shut down power if the internal temperature exceeds 60 °C. Make sure you have the replacement unit before starting this procedure.

Pre-Installation Requirements

You need the following tools and equipment to remove and replace a fan tray in a BlackDiamond 12804 switch:

- ESD-preventive wrist strap
- #2 Phillips screwdriver
- Replacement BlackDiamond 12804 fan tray

Removing the Fan Tray

To remove a fan tray from the BlackDiamond 12804 switch:

- 1 Attach the ESD-preventive wrist strap to your wrist and connect the metal end to the ground receptacle on the top-left corner of the switch chassis.
- 2 Locate the captive screws at the top and bottom of the fan tray.
- 3 Using a #2 Phillips screwdriver, loosen each captive screw as shown in [Figure 77](#).

Figure 77: Removing the Fan Tray from the BlackDiamond 12804 Switch

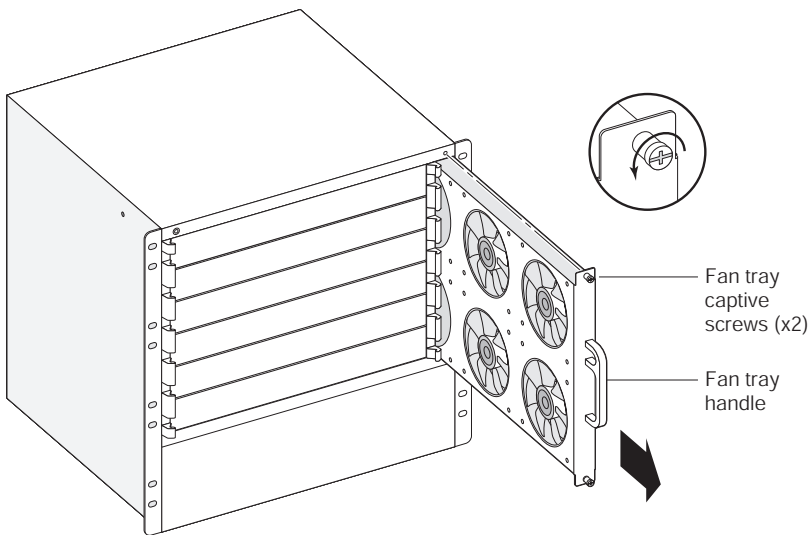

EX_114

- 4 Use the fan tray handle to pull the fan tray half-way out from the fan tray slot. This action disconnects the fan tray from the switch power.

Wait for the fan blades to stop turning before continuing with this procedure.



WARNING!

Be sure that all fan blade motion has ceased before continuing to remove the fan tray.

- 5 Support the bottom of the fan tray with your free hand as you use the handle to slide the fan tray completely out from the fan tray slot.



CAUTION

Be sure that both hands are used to support the weight of the fan tray during removal.

Leave the ESD-preventive wrist strap permanently connected to the switch so that it is always available when you need to touch ESD-sensitive components.

Installing the Replacement BlackDiamond 12804 Fan Tray

To install a replacement fan tray into the BlackDiamond 12802 switch:

- 1 Attach the ESD-preventive wrist strap to your wrist and connect the metal end to the ground receptacle on the top left corner of the switch.
- 2 Support the bottom of the fan tray with one hand as you lift the fan tray by the handle using the other hand. Align the spare fan tray with the fan tray slot on the switch, and then slide the fan tray into place in the switch (see [Figure 78](#)).



CAUTION

Be sure that both hands are used to support the weight of the fan tray during installation.

Figure 78: Installing the Fan Tray in the BlackDiamond 12804 Switch

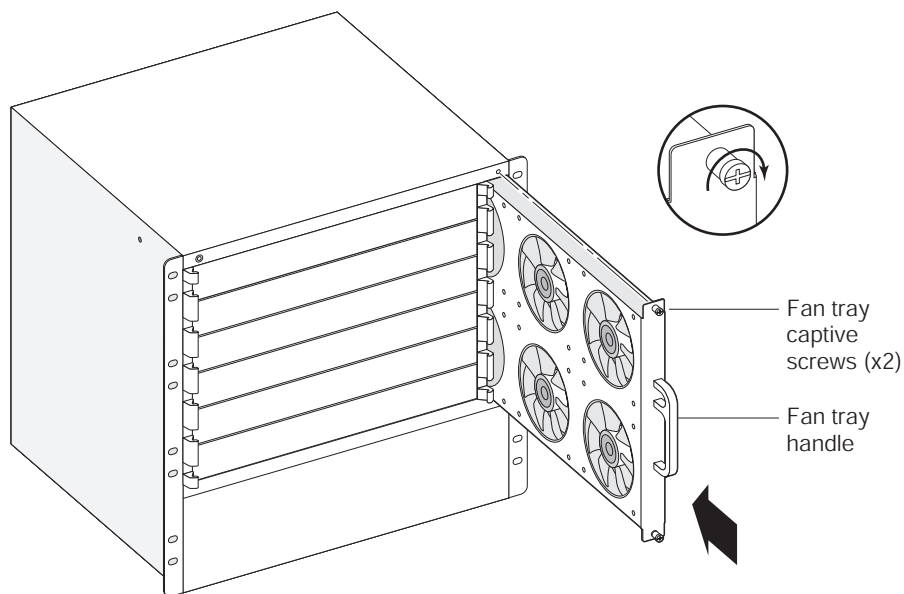

EX_115

- 3 Use a #2 Phillips screwdriver to tighten the screws ([Figure 80](#)).

Leave the ESD-preventive wrist strap permanently connected to the switch so that it is always available when you need to touch ESD-sensitive components.

Replacing the BlackDiamond 12802 Fan Tray

The BlackDiamond 12802 switch has one fan tray, which is accessible from the back of the switch.



CAUTION

Removing the fan tray for more than a few minutes may result in overheating and possible damage to the system. Thermal sensors shut down power if the internal temperature exceeds 60 °C. Make sure you have the replacement unit before starting this procedure.

Pre-installation Requirements

You must have access to the back of the BlackDiamond 12802 switch to replace the fan tray.

To replace a BlackDiamond 12802 fan tray, you need the following tools and equipment:

- ESD-preventive wrist strap
- #2 Phillips screwdriver
- Replacement BlackDiamond fan tray

Removing the BlackDiamond 12802 Fan Tray

To remove the BlackDiamond 12802 fan tray:

- 1 Attach the ESD-preventive wrist strap to your wrist and connect the metal end to the ground receptacle on the top right corner of the switch.
- 2 Locate the captive screws at the top and bottom of the fan tray ([Figure 79](#)).
- 3 Using a #2 Phillips screwdriver, loosen the screws until they are free of the switch back panel (see [Figure 79](#)).

Figure 79: Removing the Fan Tray from the BlackDiamond 12802 Switch

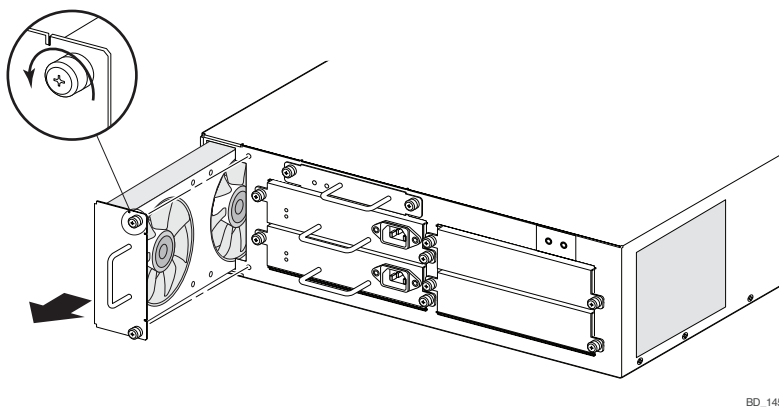

- 4 Use the fan tray handle to pull the fan tray half-way out of the fan tray slot (see [Figure 79](#)). This action disconnects the fan tray from the switch power.

Wait for the fan blades to stop turning before continuing with this procedure.

WARNING!

Be sure that all fan blade motion has ceased before continuing to remove the fan tray.

- 5 Support the bottom of the fan tray with your free hand as you use the handle to slide the fan tray completely out of the fan tray slot.

CAUTION

Use both hands to support the weight of the fan tray during removal.

Installing the Replacement BlackDiamond 12802 Fan Tray

To install the replacement BlackDiamond fan tray:

- 1 Support the bottom of the fan tray with your free hand as you lift the fan tray by the handle.
- 2 Align the fan tray with the fan tray slot on the switch, and then slide the fan tray into place in the switch (see [Figure 80](#)).



CAUTION

Use both hands to support the weight of the fan tray during installation.

Figure 80: Installing the Fan Tray in the BlackDiamond 12802 Switch

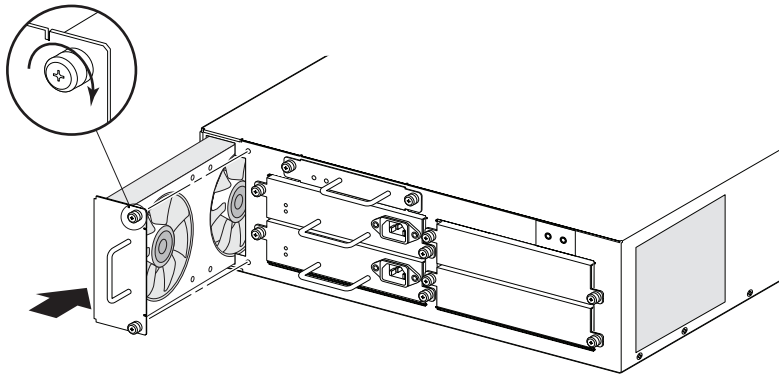

BD_146

- e Using a #2 Phillips screwdriver, tighten the captive screws (see [Figure 80](#)).

Leave the ESD-preventive wrist strap permanently connected to the switch so that the strap will always be available when you need to handle ESD-sensitive components.

9

Repacking a BlackDiamond Chassis

This chapter describes how to remove a BlackDiamond chassis from an equipment rack and repack the chassis for shipping back to Extreme Networks. To repack a BlackDiamond chassis, use the original shipping crate or box and packing materials.

This chapter includes the following sections:

- [Safety Information on page 125](#)
- [Repacking the BlackDiamond 12804 Chassis on page 126](#)
- [Repacking the BlackDiamond 12802 Chassis on page 129](#)

**NOTE**

Read the information in this chapter thoroughly before you attempt to remove a BlackDiamond chassis.

Safety Information

**CAUTION**

Correct lifting procedures for a BlackDiamond chassis require two or more people.

Only trained service personnel should perform service to Extreme Networks switches and their components. Trained service personnel have read all related installation manuals, have the technical training and experience necessary to be aware of the hazards to which they are exposed in performing a task, and are aware of measures to minimize the danger to themselves or other persons.

**NOTE**

See [Appendix A, "Safety Information"](#) for additional safety information and [Appendix B, "Technical Specifications"](#) for additional information regarding regulatory compliance certifications.

**CAUTION**

A BlackDiamond chassis should be empty before being lifted. This will also prevent damage to the system components due to possible system chassis flex when lifting.

Repacking the BlackDiamond 12804 Chassis

To repack the BlackDiamond 12804 chassis:

- 1 Remove all modules and power supplies from the BlackDiamond 12804 chassis. Follow correct Extreme Networks procedures for removing components.
- 2 Using four rack mounting screws, attach the 19-inch helper bracket to the system rack immediately below the chassis.
- 3 Remove the eight rack mounting screws that secure the chassis to the system rack.
- 4 On each side of the chassis, place one hand in the empty power supply bay and the other hand in the rear slot on the back panel of the chassis.



CAUTION

Do not use the fan tray handle to lift or maneuver the BlackDiamond 12804 chassis. This handle is not designed to support the weight of the chassis.

- 5 Slowly guide the chassis out of the system rack using the helper bracket for support.
- 6 Carefully lift the chassis off the helper bracket and lower it onto the foam cushion in the shipping carton base (see [Figure 81](#).)

Figure 81: Setting the BlackDiamond 12804 Chassis onto the Foam Cushion

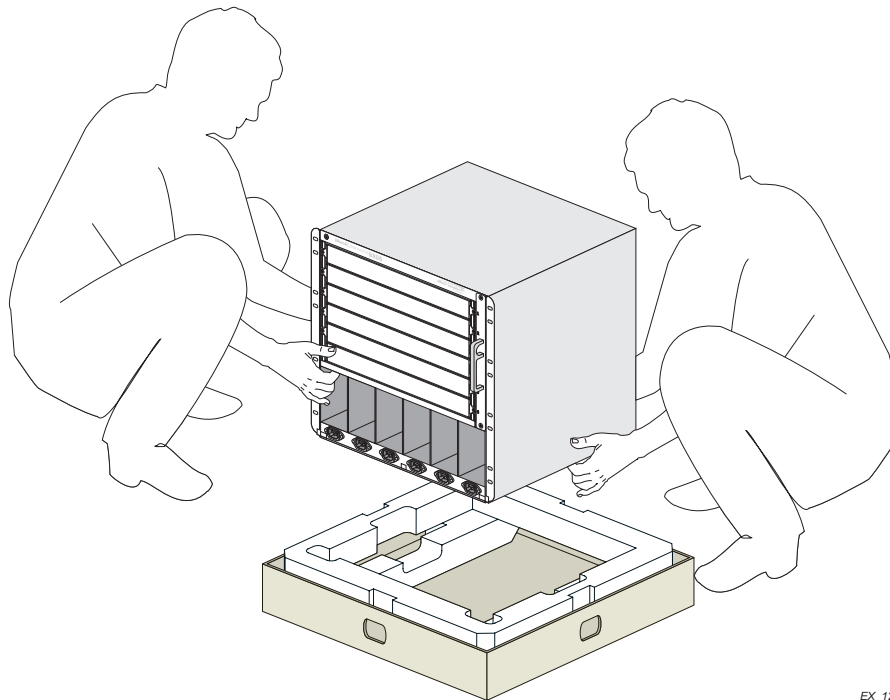

EX_129

- 7 Slide the top of the BlackDiamond shipping carton down and over the BlackDiamond 12804 chassis (see [Figure 82](#)).

Figure 82: Replacing the Carton over the BlackDiamond 12804 Chassis

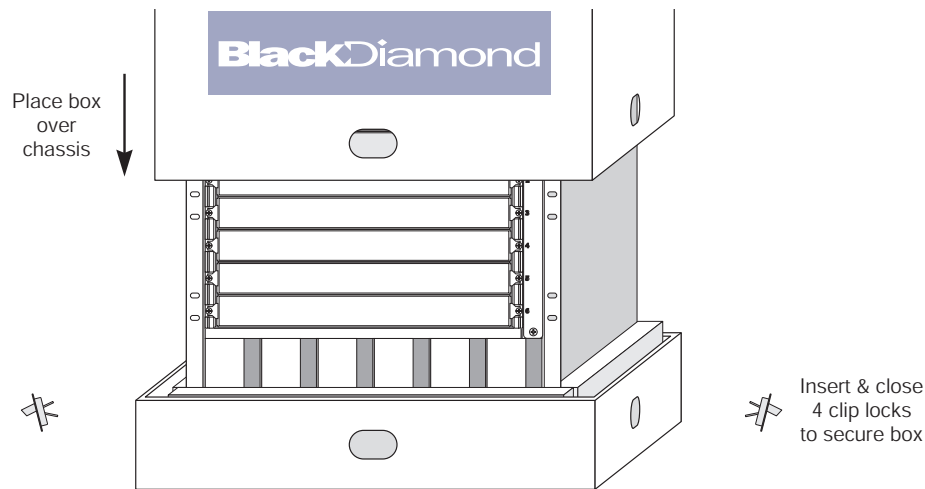

EX_121

- 8 Insert the clip locks (see [Figure 83](#)).
- Place your thumb and index finger inside the clip lock touching the prongs.
 - Squeeze the prongs inward, applying equal pressure on each side.
 - Push the prongs inward until the clip lock is secured onto the carton.
- Repeat steps 8a through 8c to insert each of the remaining clip locks.



CAUTION

Proper installation of the clip locks is critical for safe shipment of the BlackDiamond 12804 chassis. Make sure that the clip locks are secure and accurately installed.

Figure 83: Clip Locks on the BlackDiamond 12804 Chassis Shipping Carton

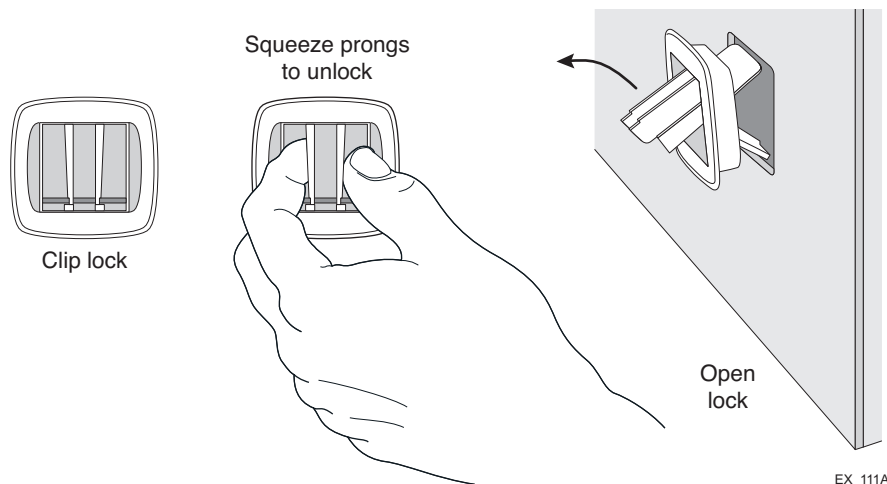

EX_111A

- 9 Place the packing foam material on top of the chassis as shown in [Figure 84](#).

Figure 84: Placing Packing Foam into the BlackDiamond 12804 Chassis Shipping Carton

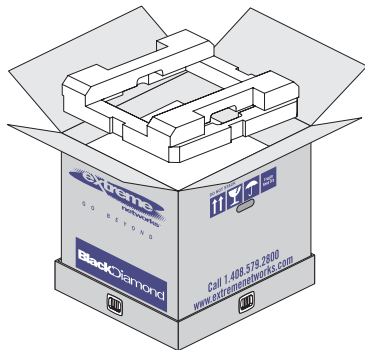

EX_110B

- 10 Close the top flaps on the shipping carton and seal them with packing tape.
- 11 Secure the shipping carton with nylon straps (see [Figure 85](#)).



NOTE

Nylon straps are optional but are recommended by Extreme Networks for extra security during shipment. The installation of nylon straps requires a crimping tool. If you do not have nylon straps and a crimping tool available to secure the carton, the chassis can be shipped without the straps; however, it is critical that the clip locks be secure before shipment.

Figure 85: Sealed BlackDiamond 12804 Chassis Shipping Carton with Nylon Straps



EX_113

Repacking the BlackDiamond 12802 Chassis

To repack the BlackDiamond 12802 chassis for return to Extreme Networks:

- 1 Prepare the shipping box. Remove saved packing materials except the lower foam cushion, which should be in the bottom of the box.
- 2 Remove all modules and power supplies from the chassis. Follow correct Extreme Networks procedures for removing components from the BlackDiamond chassis.
- 3 Remove the chassis from the equipment rack as follows:
 - a Loosen and remove the eight mounting screws holding the chassis to the rack.
 - b Guide the chassis out of the rack and set it on a secure, flat surface.
- 4 Remove the rack-mounting brackets.
- 5 Place the chassis into the shipping bag.
- 6 Carefully set the chassis onto the foam cushion in the bottom of the shipping carton (see [Figure 86](#).)

Figure 86: Packing the BlackDiamond 12802 Chassis

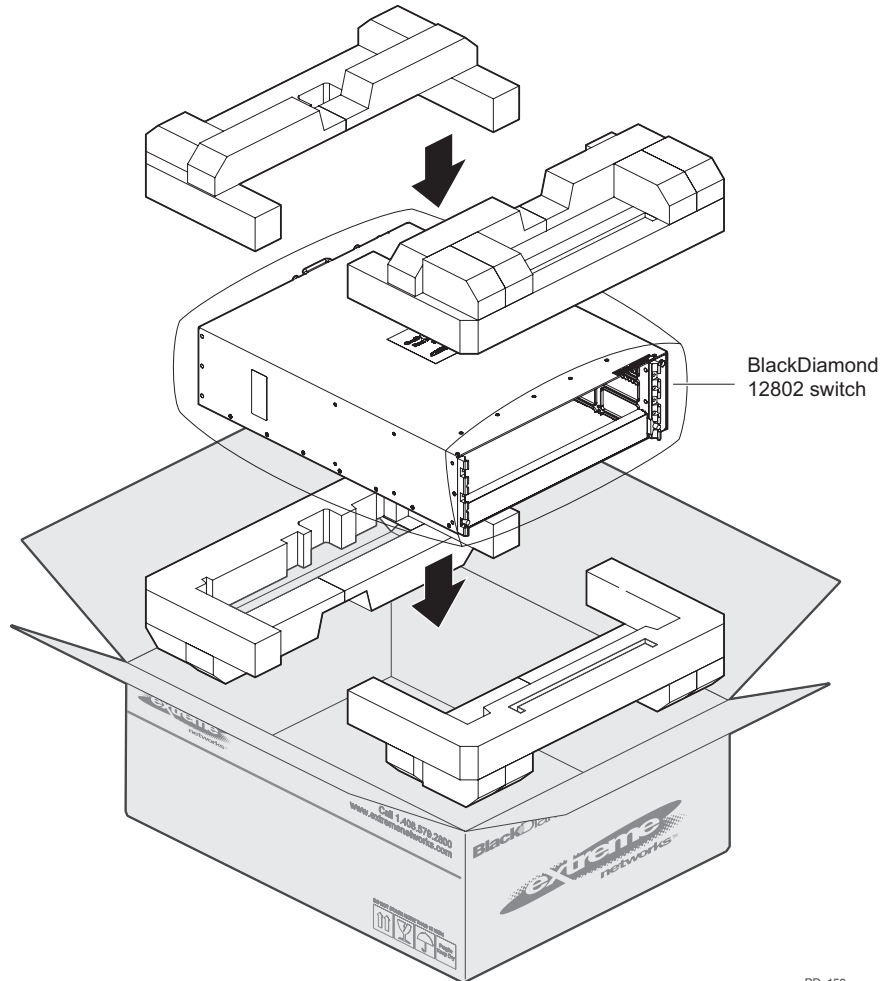

BD_150

- 7 Set the top foam cushion in place over the chassis (see [Figure 86](#)).
- 8 Close the top flaps and seal them securely with packing tape.

4**Appendixes**

A

Safety Information



WARNING!

Read the following safety information thoroughly before installing Extreme Networks products. Failure to follow this safety information can lead to personal injury or damage to the equipment.

Only trained service personnel should perform service to Extreme Networks switches and their components. Trained service personnel have read all related installation manuals, have the technical training and experience necessary to be aware of the hazards to which they are exposed in performing a task, and are aware of measures to minimize the danger to themselves or other persons.

Considerations Before Installing



WARNING!

Consider the following items before installing equipment.

Be sure that the following conditions are met:

- The system is designed to operate in a typical Telco environmental controlled environment. Choose an indoor area that has the following characteristics:
 - Temperature- and humidity-controlled, such that the maximum ambient room temperature shall not exceed 40°C (104°F)
 - Clean and free from airborne materials that can conduct electricity.
 - Well ventilated and away from sources of heat including direct sunlight.
 - Away from sources of vibration or physical shock.
 - Isolated from strong electromagnetic fields produced by electrical devices.
 - Secured, enclosed, and restricted access, ensuring that only trained and qualified service personnel have access to the equipment.
- Establish at least 3 inches clearance on all sides for effective ventilation. Do not obstruct the air intake vent on the front, side, or rear ventilation grills. Locate the system away from heat sources.
- Make sure that your equipment is placed in an area that accommodates the power consumption and component heat dissipation specifications.
- Make sure that your power supplies meet the site power or AC power requirements of all network equipment.

Installing Power Supply Units

For the ratings and power requirements of each power supply unit, see [Appendix B, “Technical Specifications”](#) or the data sheet for the power supply at <http://www.extremenetworks.com>.



WARNING!

Be sure that the requirements listed in this section are satisfied when installing all Extreme Networks power supplies.

When you install power supplies:

- Plug power supplies only into properly grounded electrical outlets to help prevent electrical shock and comply with international safety standards.
- Use only power cords that are certified for use within the country of use. Do not attempt to modify AC power cords.
- Make sure the wall outlet is installed near the equipment and is easily accessible for quick disconnect.
- Make sure the voltage and frequency of your power outlet match the system electrical ratings for the equipment. The building and/or power source must provide overload protection.
- Use a surge suppressor, line conditioner, or uninterruptible power supply to protect the system from momentary increases or decreases in electrical power.
- When inserting a hot-swappable power supply into the bay, do not use excessive force.
- If multiple power supplies are used in a switch, connect each power supply to a different, independent power source. If a single power source fails, it will affect only that power supply to which it is connected. If all the power supplies on a single switch are connected to the same power source, the entire switch is vulnerable to a power failure.



WARNING!

Extreme Networks 325 W DC PSUs do not have switches for turning the unit on and off. Make sure that the DC circuit is de-energized before connecting or disconnecting the DC power cord at the DC power socket on the Extreme Networks 325 W DC PSU.

Wiring the 325 W DC PSU DC power cord to your facility DC source voltage must be performed by a qualified, licensed electrician.

Extreme Networks 325 W AC PSUs do not have switches for turning the unit on and off. Remove the wall plug from the electrical outlet to disconnect the power from an Extreme Networks 325 W AC PSU. Make sure that this connection is easily accessible.

Do not connect the power supply to an electrical outlet when the power supply is outside the chassis; doing so would expose a hazardous energy and poses a potential shock and fire hazard.

Do not put your hand into an open power supply bay when a power supply is not present. Empty power supply bays require a cover plate at all times.

Maintenance Safety

When you perform maintenance procedures on Extreme Networks equipment, follow these recommendations:

- Use only original accessories or components approved for use with this system. Failure to follow these instructions may damage the equipment or violate required safety and EMC regulations.
- The chassis cover should only be removed by Extreme Networks personnel. There are no customer serviceable components in this system. Repairs to the system must be performed by an Extreme Networks factory service technician.
- In systems that have power-on buttons, the power on button may not turn off all system power. To remove power from the system, you must unplug all power cords from wall outlets. The power cord is the disconnect device to the main power source.
- Disconnect all power before removing the back panel of any Extreme Networks switch, unless otherwise instructed by a product-specific maintenance procedure.
- Disconnect all power cords before working near power supplies, unless otherwise instructed by a maintenance procedure.
- When handling modules, optic devices, power supplies, or other modular accessories put on the ESD-preventive wrist strap to reduce the risk of electronic damage to the equipment. Connect the other end of the strap to the ESD connector on the front of the chassis. Leave the ESD-preventive wrist strap permanently attached to the chassis so that it is always available when you need to handle ESD-sensitive components.
- Install all cables in a manner that avoids strain. Use tie wraps or other strain relief devices.
- Replace a power cord immediately if it shows any signs of damage.

General Safety Precautions

Follow these guidelines:

- Do not try to lift objects that you think are too heavy for you.
- When you install equipment in a rack, load heavier devices in the lower half of the rack first to avoid making the rack top-heavy.
- Only use tools and equipment that are in perfect condition. Do not use equipment with visible damage.
- Routing cables: Route cables in a manner that prevents possible damage to the cables and avoids causing accidents, such as tripping.

Cable Routing for LAN Systems

The BlackDiamond 12800 series switches meet the requirements for LAN system equipment. LAN systems are designed for intra-building installations; that is, cable runs between devices must be in the same building as the connected units.

This equipment can be connected between buildings if any one of the following conditions is true:

- Cable runs between buildings are less than 140 feet long.
- Cable runs between buildings are directly buried.
- Cable runs between buildings are in an underground conduit, where a continuous metallic cable shield or a continuous metallic conduit containing the cable is bonded to each building grounding electrode system.



CAUTION

Failure follow these requirements for cable routing conditions may expose the user to electrical shock and expose the unit to errors or damage.

PoE Devices

When connecting power over Ethernet (PoE) devices to a PoE switch, all connections between the PoE device and the switch must remain inside the same building and use a low-voltage power distribution system per IEEE 802.3af.

Selecting Power Supply Cords

Extreme Networks provides power input cords shipped in the product box for use in the US and Canada. Power supply cords for use outside of the United States and Canada are typically provided separately by third-party distribution centers. Contact the Extreme Networks TAC for questions regarding the proper selection of a power input cord for your specific switch.

The following are power cord requirements for use on Extreme switches:

Black Diamond SSI AC PSU Model 60020:

- Wire: 16 AWG (1.31 mm²) minimum, 3-conductor flexible cable, Type SVT, SJT, HAR or equivalent, no longer than 10ft
- Wall plug: Suitable for use in country of installation & approved by local regulatory authority
- Device connector: IEC320-C13, 90 degree angle, rated at 15 A, 250 VAC
- Power cord assembly: Must be rated at 10A by in-country regulatory authority

Black Diamond SSI DC PSU, Model 60021:

- Wire: three conductor, 8 AWG, jacketed, and marked 90C min

**NOTE**

Tray Cable is a UL US-only requirement. Outside United States standard 8 AWG (8.35mm²), 90C wire is acceptable.

- Wall plug: N/A, 3-conductor wires have been stripped and are ready for connection to DC power source mains
- Device connector: Molex Shell Connector PN 42816-0312; Molex Pin Connectors PN 42815-0032
- Assembly rating: 75VDC, 30A, (Do not disconnect under load)

Black Diamond 325 W AC PSU Model 65021:

- Wire: 18 AWG (0.82mm²) minimum, 3-conductor flexible cable, Type SVT, SJT, HAR or equivalent, no longer than 10ft
- Wall plug: Suitable for use in country of installation & approved by local regulatory authority
- Device connector: IEC320-C13, 90 degree angle, rated at 15 A, 250 VAC
- Power cord assembly: Must be rated at 10A by in-country regulatory authority

Black Diamond 325 W DC PSU, Model 60021:

- Wire: UL LISTED, three conductor, 14 AWG, jacketed, and marked (UL) FT2, 90C min

**NOTE**

Tray Cable is a UL US-only requirement. Outside United States standard 8 AWG (8.35mm²), 90C wire is acceptable.

- Wall plug: N/A, 3-conductor wires have been stripped and are ready for connection to DC power source mains
- Device connector: Molex Shell Connector PN 42816-0312; Molex Pin Connectors PN 42815-0032
- Assembly rating: 75VDC, 30A, (Do not disconnect under load)

**WARNING!**

When using multiple power supplies, make sure that each power supply is attached to independent circuits breakers. See PS installation instructions of PS for proper sizing of circuit breaker.

Make sure that the source outlet is properly grounded according to the country's local electrical requirements before plugging the AC supply power cord into a PSU.

For specific product input power requirements refer to the data sheet of the product or modular PSU at <http://www.extremenetworks.com> or to Appendix B of this guide.

The following countries have specific safety instructions concerning power connectors:

- Argentina: The supply plug must comply with Argentinean standards.
- Australia: Use AS 3112 for 110/220 VAC power supplies.
- Denmark: The supply plug must comply with section 107-2-D1, standard DK2-1a or DK2-5a.
- International: Use CEE 7/7 for 110/220 VAC power supplies.
- Japan:

- Use JIS 8303 for 110/220 VAC power supplies.
- The power cord provided with the power supply, switch, or chassis is for use only with that specific product from Extreme Networks; it is not for use with any other product from Extreme Networks or any other vendors' equipment.
- North America: The cord set must be cULus listed or cCSAus listed.
- Switzerland: The supply plug must comply with SEV/ASE 1011.
- United Kingdom: Use BS 1363 for 110/220 VAC power supplies.

**NOTE**

This equipment is not intended to be directly powered by power distribution systems where phase-phase voltages exceed 240V AC (2P+PE), such as those used in Norway, France, and other countries. For these applications it is recommended that a transformer be used to step down the voltage to < 240V AC from phase-phase, or that you make a connection to a (P+N+PE) power distribution where voltages do not exceed 240V AC.

All installations should confirm that the product is reliably grounded according to the country's local electrical codes.

**NOTE**

Building codes vary worldwide; therefore, Extreme Networks strongly recommends that you consult an electrical contractor to ensure proper equipment grounding and power distribution for your specific installation & country.

Battery Replacement and Disposal

Batteries included with Extreme products are encapsulated and must be replaced by qualified Extreme Service personnel only. Contact your Extreme Service personnel for product replacement. Do not attempt to replace the battery. If these instructions are disregarded and replacement of these batteries is attempted, the following guidelines must be followed to avoid danger of explosion:

- 1 Replace with same or equivalent battery type as recommended by the battery manufacturer.
- 2 Dispose of battery in accordance with the battery manufacturer's recommendation.

Fiber Optic Ports—Optical Safety

The following safety warnings apply to all optical devices used in Extreme Networks equipment that are removable or directly installed in an I/O module or chassis system. Such devices include but are not limited to gigabit interface converters (GBICs), small form factor pluggable (SFP) modules (or mini-GBICs), XENPAK transceivers, and XFP laser optic modules.

**WARNING!**

Laser optic modules become very hot after prolonged use. Take care when removing a laser optic module from the chassis or option card. If the laser optic module is too hot to touch, disengage the laser optic module and allow it to cool before removing it completely.

**WARNING!**

When working with laser optic modules, always take the following precautions to avoid exposure to hazardous radiation.

- Never look at the transmit LED/laser through a magnifying device while it is powered on.
- Never look directly at a fiber port on the switch or at the ends of a fiber cable when they are powered on.
- Invisible laser radiation can occur when the connectors are open. Avoid direct eye exposure to the beam when optical connections are unplugged.
- Never alter, modify, or change an optical device in any way other than suggested in this document.

GBIC, SFP (Mini-GBIC), XENPAK, and XFP Regulatory Compliance

Extreme Networks pluggable optical modules meet the following regulatory requirements:

- Class 1 Laser Product
- EN60825-1+A2:2001 or later, European laser standard
- FCC 21 CFR Chapter 1, Subchapter J in accordance with FDA & CDRH requirements
- Application of CE Mark in accordance with 89/336/EEC EMC and 73/23/EEC Low Voltage Directives
- UL and/or CSA registered component for North America
- 47 CFR Part 15, Class A when installed into Extreme products

**NOTE**

Extreme Networks optical modules are tested to work in all supported Extreme Networks switches. We recommend that all customers use Extreme Networks optical modules in their Extreme Networks switches. Extreme Networks assumes no liability for third-party optical modules. Although Extreme Networks does not block third-party optical modules, we cannot ensure that all third-party optical modules operate properly in all Extreme Networks switches. The customer assumes all risks associated with using third-party optical modules in Extreme Networks switches.

Sicherheitshinweise



WARNUNG!

Vor der Installation der Produkte von Extreme Networks sind die nachfolgenden Sicherheitshinweise aufmerksam zu lesen. Die Nichtbeachtung dieser Sicherheitshinweise kann zu Verletzungen oder Schäden an der Ausrüstung führen.

Installation, Wartung und Ausbau eines Switch, einer Grundplatte oder einer seiner Komponenten dürfen nur von geschultem und qualifiziertem Servicepersonal durchgeführt werden! Geschulte und qualifizierte Servicetechniker verfügen über die erforderliche technische Ausbildung und Erfahrung, um mögliche Gefahren bei der Durchführung von Servicearbeiten zu erkennen und Maßnahmen zur Minimierung der Gefahr für sich bzw. andere zu treffen.

Hinweise zur Installation



WARNUNG!

Beachten Sie vor der Installation der Ausrüstung folgende Punkte.

Stellen Sie sicher, dass die nachfolgend aufgeführten Bedingungen erfüllt sind:

- Das System ist für den Einsatz in einer typischen Umgebung gemäß Telco-Vorgaben vorgesehen. Wählen Sie einen Aufstellort mit den folgenden Eigenschaften:
 - Innenbereich mit Temperatur- und Feuchtigkeitsregelung, wobei die maximale Raumtemperatur 40°C (104°F) nicht überschreiten darf.
 - Sauber und frei von elektrisch aufladbaren Teilchen in der Luft.
 - Ausreichende Belüftung und Abstand zu Wärmequellen, einschließlich direktem Sonnenlicht
 - Ausreichender Abstand zu Quellen, die Erschütterungen oder Schläge/Stöße hervorrufen können
 - Isolierung von starken elektromagnetischen Feldern, wie sie durch Elektrogeräte erzeugt werden
 - Sicherer, abgeschlossener Arbeitsbereich mit beschränktem Zugang, sodass nur geschultes und qualifiziertes Servicepersonal Zugriff auf das Gerät hat
 - In für elektrische Stürme anfälligen Gebieten wird empfohlen, das System an einen Spannungsstoßunterdrücker anzuschließen.
 - Die Ausrüstung im unteren Teil des Gestells installieren, um zu vermeiden, dass der obere Teil des Gestells zu schwer wird.
 - Auf allen Seiten für mindestens 7,5 cm (3") Abstand sorgen, um eine ausreichende Belüftung zu gewährleisten. Die Lufteinlassöffnung an den vorderen, seitlichen und hinteren Entlüftungsgittern nicht blockieren. Das System nicht in der Nähe von Wärmequellen aufstellen.
- Sicherstellen, dass die Ausrüstung in einem Bereich aufgestellt wird, der den Spezifikationen für Leistungsaufnahme und Wärmeabstrahlung der Komponenten entspricht.
- Sicherstellen, dass Ihre Netzteile die Anforderungen an die Strom- oder Wechselstromversorgung vor Ort für alle Netzwerkgeräte erfüllen.

- Bei den Extreme-Produkten handelt es sich um digitale Geräte der Klasse A gemäß Teil 15 der FCC-Richtlinien und anderen internationalen Richtlinien. Der Gerätebetrieb unterliegt den folgenden Voraussetzungen: (1) Das Gerät kann schädliche Interferenzen verursachen, und (2) das Gerät muss jede empfangene Interferenz zulassen, einschließlich einer Interferenz, die einen unerwünschten Betrieb verursachen kann.

Installation von Netzteilen



WARNUNG!

Bei der Installation sämtlicher Netzteile von Extreme Networks muss sichergestellt werden, dass die nachfolgend aufgeführten Anforderungen erfüllt sind. Angaben zu Nennleistung und Leistungsbedarf finden sich in den Installationsanweisungen für das jeweilige Netzteil (Power Supply Unit, PSU).

Folgende Anforderungen müssen unbedingt erfüllt sein:

- Wenn der mit Wechsel- oder Gleichstrom betriebene Switch von Extreme Networks mit einem externen grünen/gelben Erdungskabel ausgestattet ist, dann muss zunächst dieses Erdungskabel zwischen der Grundplatte und einem geeigneten Erdungspunkt angeschlossen werden, bevor andere Verbindungen zum Gerät hergestellt werden; dies gilt auch für den Anschluss an das Wechsel- bzw. Gleichstromnetz. Beim Ausbau des Geräts aus dem Gestell muss das Erdungskabel als letztes getrennt werden.
- Netzteile nur an vorschriftsmäßig geerdete Steckdosen anschließen, um die Gefahr elektrischer Schläge zu vermeiden und die Konformität mit internationalen Sicherheitsnormen zu gewährleisten.
- Nur Stromkabel verwenden, die für den Einsatz in dem jeweiligen Land zugelassen sind. Wechselstromkabel dürfen nicht manipuliert werden.
- Die Wandsteckdose muss in der Nähe der Anlage installiert und leicht zugänglich sein, um eine schnelle Trennung vom Netz zu ermöglichen.
- Spannung und Frequenz der Steckdose müssen den elektrischen Nenndaten des Systems entsprechen. Das Gebäude bzw. die Stromquelle muss mit einem Überlastschutz ausgestattet sein.
- Einen Spannungsstoßunterdrücker, einen Netzfilter oder eine unterbrechungsfreie Stromversorgung verwenden, um das System vor einer vorübergehenden Zu- oder Abnahme der elektrischen Leistung zu schützen.
- Bei laufendem Betrieb austauschbare Netzteile: Das Netzteil vorsichtig, nicht mit Kraft in das Aufnahmefach einsetzen.
- Bei Einsatz mehrerer Netzteile in einem Switch sind die Netzteile jeweils an unterschiedliche, unabhängige Stromquellen anzuschließen. Auf diese Weise ist bei einem Ausfall einer einzelnen Stromquelle nur das daran angeschlossene Netzteil betroffen. Wenn alle Netzteile eines einzelnen Switch an dieselbe Stromquelle angeschlossen sind, ist der gesamte Switch für einen Ausfall der Stromversorgung anfällig.

Leistungsspezifikationen für Netzteile von Extreme Networks finden sich in Anhang B dieses Dokuments oder im Netzteil-Datenblatt unter <http://www.extremenetworks.com>.



WARNUNG!

Die 325 W DC-Netzteile von Extreme Networks sind nicht mit Ein-/Ausschaltern ausgestattet. Vor dem Einstecken des Gleichstromkabels in den Gleichstromanschluss des 325 W DC-Netzteils von Extreme Networks sowie vor dem Abziehen des Kabels sicherstellen, dass der Gleichstromkreis abgeschaltet ist.

Das Gleichstromkabel des 325 W DC-Netzteils muss von einem qualifizierten, zugelassenen Elektriker an die Gleichspannungsquelle in Ihrem Gebäude angeschlossen werden.

Extreme Networks 325 W AC Netzteile haben keinen An- Aus Schalter. Die Stromzufuhr zu einem Extreme Networks 325 W AC Netzteil wird durch das Ziehen des Netzkabels unterbrochen. Es ist sicherzustellen das diese Verbindung leicht zugänglich ist.

Das Netzteil nicht ausserhalb von dem Gehäuse an das Netz anschliessen da hierdurch gefährliche Spannungen zugänglich werden sowie die Gefahr von einem elektrischem Schlag und/ oder Feuergefahr besteht.

Nicht die Hand in den Netzteilschacht einführen wenn das Netzteil entfernt ist. Leere Netzteilschächte müssen immer mit eine Abdeckplatte bedeckt sein.

Wartungssicherheit

Folgende Vorsichtsmaßnahmen müssen getroffen werden:

- Nur für den Einsatz mit diesem System zugelassene Originalzubehöerteile bzw. -komponenten verwenden. Die Nichtbeachtung dieser Anweisungen kann zu Schäden an der Ausrüstung oder sogar zu einem Verstoß gegen die erforderlichen Sicherheitsbestimmungen und EMV-Vorschriften führen.
- Die Abdeckung der Grundplatte darf nur durch Personal von Extreme Networks entfernt werden. Das System enthält keine vom Kunden zu wartenden Komponenten. Reparaturen am System sind von einem Werkstechniker von Extreme Networks durchzuführen.
- Der An-/Aus-Schalter des Systems darf nicht die gesamte Stromversorgung zum System unterbrechen. Zur Unterbrechung der Wechselstromversorgung zum System müssen alle Stromkabel aus den Wandsteckdosen gezogen werden. Das Stromkabel dient zur Trennung von der Netzstromversorgung.
- Vor dem Entfernen der Rückwand eines Extreme Networks-Switch muss die gesamte Stromzufuhr unterbrochen werden.
- Vor der Aufnahme von Arbeiten in der Nähe von Stromquellen alle Stromkabel abziehen, sofern nicht im Rahmen eines Wartungsverfahrens anders vorgegeben.
- Beim Umgang mit Modulen, optischen Geräten, Netzteilen oder anderen modularen Zubehörteilen das ESD-Schutzarmband anlegen, um das Risiko einer Beschädigung der Geräte durch elektrostatische Entladungen zu verringern. Das Armband zum Schutz elektrostatisch gefährdeter Bauteile (ESB) grundsätzlich an der Grundplatte befestigt lassen, damit es beim Umgang mit diesen Bauteilen immer zur Hand ist.
- Alle Kabel so verlegen, dass übermäßige Belastungen vermieden werden. Kabelbinder oder Zugentlastungsklemmen verwenden.
- Ein Stromkabel bei Anzeichen von Beschädigungen unverzüglich austauschen.

Allgemeine Sicherheitsvorkehrungen

Folgende Richtlinien sind unbedingt zu befolgen:

- Keine Gegenstände heben, die möglicherweise zu schwer sind.
- Bei einer Installation in einem Gestell darauf achten, dass schwere Geräte unten im Gestell eingebaut werden, um Gefahren durch Umkippen zu vermeiden.
- Bei Summit Desktop-Switches keinen Monitor oder andere Gegenstände auf die Anlage stellen. Die Abdeckung der Grundplatte ist nicht darauf ausgelegt, Gewicht zu tragen.

- Nur Werkzeuge und Ausrüstung verwenden, die sich in einwandfreiem Zustand befinden. Keine Ausrüstung verwenden, die sichtbare Beschädigungen aufweist.
- Verlegen von Kabeln: Kabel so verlegen, dass keine Schäden entstehen oder Unfälle, z. B. durch Stolpern, verursacht werden können.

Auswahl der Stromkabel

Je nachdem, welchen Switch Sie erworben haben, werden die Wechselstromnetzteile von Extreme Networks entweder nur mit einem 110-VAC-Kabel oder mit einem 110-VAC-Kabel und einem 208/220-VAC-Kabel geliefert. Die von Extreme Networks gelieferten Stromkabel sind nur für den Einsatz in den Vereinigten Staaten und Kanada ausgelegt und zugelassen. Stromkabel für den Einsatz außerhalb der Vereinigten Staaten und Kanada werden normalerweise von einem Drittanbieter geliefert und müssen die folgenden Anforderungen erfüllen:

- Die Stromkabel müssen offiziell für das Land zugelassen sein, in dem sie verwendet werden sollen.
- Die Stromkabel müssen mit einem für das Einsatzland zugelassenen Wandsteckkontakt mit der geeigneten Nennleistung ausgerüstet sein.
- Die Konfiguration der Steckvorrichtung (die Steckverbindung zur Einheit, nicht zur Wandsteckdose) muss für eine Gerätesteckdose gemäß EN60320/IEC320-C14 ausgeführt sein.
- Die Länge der Stromkabel muss weniger als 5 m (15 Fuß) betragen.
- Die Mindestspezifikation für das flexible Kabel lautet:
 - Nr. 18 AWG (0,823 mm²) für Einheiten mit einem Bemessungsstrom von weniger als 10 A, oder
 - Nr. 18 AWG (0,823 mm²) bis 2 m Länge für Einheiten mit einem Bemessungsstrom von 10 A oder höher, oder
 - Nr. 16 AWG (1,0 mm²) bis 5 m Länge für Einheiten mit einem Bemessungsstrom von 10 A oder höher
- Bei allen Kabeln muss es sich um 3-adrige Kupferleiter vom Typ SVT oder SJT, HAR oder einen äquivalenten Typ handeln.

Verwenden Sie immer ein Wechselstromkabel, das den Vorschriften Ihres Landes entspricht. Erkundigen Sie sich über die örtlichen Vorschriften für Elektroinstallationen und fragen Sie bei den zuständigen Aufsichtsbehörden nach den Anforderungen an Stromkabel. Nähere Angaben zu den Leistungsspezifikationen von Netzteilen finden sich unter <http://www.extremenetworks.com> oder in Anhang B dieses Dokuments.



WARNUNG!

Vor dem Anschließen des Wechselstromkabels an ein Netzteil muss sichergestellt werden, dass die Steckdose vorschriftsgemäß geerdet ist.

Für die unten aufgeführten Länder gelten zusätzlich folgende Anforderungen:

- Argentinien: Der Netzstecker muss den argentinischen Standards entsprechen.
- Australien: Versorgungssteckdose, 15 A Minimum, AS 3112 für 110/220-VAC-Netzteile
- Dänemark: Der Netzstecker muss die in Abschnitt 107-2-D1 der Norm DK2-1a oder DK2-5a aufgeführten Bestimmungen erfüllen.
- Japan:
 - Versorgungssteckdose, 15 A, JIS 8303 für 110/220-VAC-Netzteile.

- Das mit dem Netzteil, dem Switch oder der Grundplatte gelieferte Verbindungskabel ist nur für den Einsatz mit dem spezifischen Produkt von Extreme Networks vorgesehen und darf nicht mit anderen Geräten von Extreme Networks oder anderen Anbietern verwendet werden.
- Nordamerika: Versorgungssteckdose, 15 A, NEMA 5-15 für 110-VAC-Netzteile und NEMA L6-15P für 208/220-VAC-Netzteile
- Schweiz: Der Netzstecker muss der Richtlinie SEV/ASE 1011 entsprechen.
- Großbritannien: Versorgungssteckdose, 15 A, BS 1363 für 110/220-VAC-Netzteile
- International: Versorgungssteckdose, 15 A, CEE 7/7 für 110/220-VAC-Netzteile
- Nur Frankreich und Peru:
Diese Einheit kann nicht über IT+-Netzteile mit Strom versorgt werden. Wenn Ihre Netzteile vom Typ IT sind, muss dieses Gerät mit 230 V (2P+T) unter Verwendung eines Trenntrafos mit einem Verhältnis von 1:1 versorgt werden. Der zweite Anschlusspunkt muss als neutral definiert und direkt an die Erde angeschlossen werden.

Hinweis: Die Bauvorschriften sind weltweit verschieden; Extreme Networks empfiehlt daher ausdrücklich, einen Elektroinstallateur zu beauftragen, um die sachgemäße Geräteerdung und Stromverteilung für Ihre spezifische Installation sicherzustellen.

Austauschen und Entsorgen von Batterien

Im Umgang mit Batterien sind folgende Hinweise zu beachten:

- **Austauschen der Lithium-Batterie:** Die in diesem Gerät enthaltenen Batterien können nicht vom Anwender ausgetauscht werden. Wenden Sie sich für einen Austausch des kompletten Gerätes bitte an die Servicemitarbeiter von Extreme. Sollte der Versuch eines Austausches unternommen werden, sind zur Vermeidung einer Explosionsgefahr folgende Richtlinien zu beachten:
 - a Die Batterie nur durch eine identische oder eine gleichwertige, vom Hersteller empfohlene Batterie ersetzen.
 - b Die Batterie gemäß den Empfehlungen des Herstellers entsorgen.

Lichtleiteranschlüsse: Optische Sicherheit



WARNUNG!

Beim Umgang mit Lichtleitermodulen sind folgende Vorsichtsmaßnahmen zu beachten:

- *Niemals durch ein Vergrößerungsgerät auf die übertragende LED/den Laser schauen, wenn diese(r) eingeschaltet ist.*
- *Niemals direkt auf einen Lichtleiteranschluss am Switch oder auf die Enden eines Faserkabels schauen, wenn diese eingeschaltet sind.*
- *Bei offenen Anschlüssen kann es zu unsichtbarer Laserstrahlung kommen. Direkter Augenkontakt mit dem Strahl ist zu vermeiden.*
- *Ein optisches Gerät niemals auf andere Weise verändern oder modifizieren als in diesem Dokument angegeben.*

Einhaltung behördlicher Vorschriften durch GBIC, SFP (Mini-GBIC), XENPAK und XFP

- Laserprodukt der Klasse 1
- EN60825-1+A2:2001 oder jünger, Europäische Richtlinie für Lasersysteme
- Anwendung der CE-Kennzeichnung gemäß der Richtlinien 89/336/EWG EMV und 73/23/EWG für Niederspannungsgeräte

B

Technical Specifications

This appendix includes the following technical specifications:

- [BlackDiamond 12804 Switch on page 147](#)
- [BlackDiamond 12802 Switch on page 149](#)
- [Power Supplies for the BlackDiamond 12800 Series Switches on page 151](#)
- [Connector Pinouts on page 153](#)



NOTE

The power supply specifications for the BlackDiamond family of switches are consolidated into one table: [Table 26](#).

BlackDiamond 12804 Switch

Table 24: BlackDiamond 12804 Switch Technical Specifications

Physical Dimensions

BlackDiamond 12804 chassis	Height: 17.47 inches (44.4 cm) Width: 17.51 inches (44.5 cm) Depth: 18.12 inches (46.0 cm)
----------------------------	--

Weight

BlackDiamond 12804 chassis (empty)	63.75 lb (29.0 kg)
BlackDiamond 12804 chassis (fully loaded)	153 lb (69.5 kg)
BlackDiamond 12804 power supply	7 lb (3.2 kg)
BlackDiamond 12804 fan tray	4.75 lb (2.2 kg)
BlackDiamond 12804 PSU/Fan Controller	1.75 lb (.79 kg)

Safety Standards

North American Safety of ITE	UL 60950-1:2003 1st Ed., Listed Device (US) CSA 22.2#60950-1-03 1st Ed.(Canada) Complies with FCC 21CFR 1040.10 (US Laser Safety) CDRH Letter of Approval (US FDA Approval) NOM/NYCE (Mexico) IEEE 802.3af 6-2003 Environment A for PoE Applications
European Safety of ITE	EN 60950-1:2001+A11 EN 60825-1+A2:2001 (Lasers Safety) TUV-R GS Mark by German Notified Body 73/23/EEC Low Voltage Directive
International Safety of ITE	CB Report & Certificate per IEC 60950-1:2001 Country Deviations AS/NZX 60950-1 (Australia /New Zealand)

Table 24: BlackDiamond 12804 Switch Technical Specifications (Continued)

EMI/EMC Standards

North America EMC for ITE	FCC CFR 47 part 15 Class A (USA) ICES-003 Class A (Canada)
European EMC standards	EN 55022:1998 Class A EN 55024:1998 Class A includes IEC 61000-4-2, 3, 4, 5, 6, 8, 11 EN 61000-3-2,3 (Harmonics & Flicker) ETSI EN 300 386:2001 (EMC Telecommunications) 89/336/EEC EMC Directive
International EMC certifications	CISPR 22:1997 Class A (International Emissions) CISPR 24:1997 Class A (International Immunity) IEC/EN 61000-4-2 Electrostatic Discharge, 8kV Contact, 15kV Air, Criteria A IEC/EN 61000-4-3 Radiated Immunity 10V/m, Criteria A IEC/EN 61000-4-4 Transient Burst, 1kV, Criteria A IEC/EN 61000-4-5 Surge, 2kV, 4kV, Criteria A IEC/EN 61000-4-6 Conducted Immunity, 0.15-80MHz, 10V/m unmod. RMS, Criteria A IEC/EN 61000-4-11 Power Dips & Interruptions, >30%, 25 periods, Criteria C
Country-specific	VCCI Class A (Japan Emissions) AS/NZS 3548 ACA (Australia Emissions) CNS 13438:1997 Class A (BSMI-Taiwan) MIC Mark, EMC Approval (North Korea)

Telecom Standards

ETSI EN 300 386:2001 (EMC Telecommunications)
ETSI EN 300 019 (Environmental for Telecommunications)

IEEE 802.3 Media Access Standards

Note: These standards are module-specific and may not apply to every module in the series.

IEEE 802.3 10BASE-T
IEEE 802.3u 100BASE-TX, 100BASE-FX
IEEE 802.3z 1000BASE-X
IEEE 802.3ab 1000BASE-T
IEEE 802.3ac VLAN Tag
IEEE 802.3ad Link Aggregation
IEEE 802.3ae 10GBASE-X
IEEE 802.3aef Power over Ethernet

Environmental Standards

Environmental	EN/ETSI 300 019-2-1 v2.1.2 - Class 1.2 Storage EN/ETSI 300 019-2-2 v2.1.2 - Class 2.3 Transportation EN/ETSI 300 019-2-3 v2.1.2 - Class 3.1e Operational EN/ETSI 300 753 (1997-10) - Acoustic Noise
Operating conditions	Operating temperature range: 0° C to 40° C (32° F to 104° F) Operating humidity: 10% to 93% relative humidity, non-condensing Operating altitude 0 to 3000 meters (0 to 9,850 ft) Operational shock: 30 m/s ² (3 g), 11 ms, 60 shocks Operational random vibration: 5 to 500 Hz @ 1.5g rms

Table 24: BlackDiamond 12804 Switch Technical Specifications (Continued)

Storage & Transportation Conditions (Packaged)	Transportation temperature: -40°C to 70°C (-40°F to 158°F) Storage and transportation humidity: 10% to 93% relative humidity, non-condensing Packaged shock (half sine): <50 kg 180 m/s ² (10 g), 6 ms, 600 shocks, modules >50 kg 100 m/s ² (6 g), 11 ms, 600 shocks, chassis Packaged random vibration: 5 to 20 Hz @ 1.0 ASD w/-3 dB/oct. from 20 to 200 Hz Packaged sinusoidal vibration: 5 to 62 Hz, 5 mm/s velocity, 62 to 200 Hz, 0.2 g Tilt: 22.5 degrees and return to position 14 drops minimum on sides & corners @ 39.4" <20 lb (9 kg) modules @ 19.7" <80 lb (36 kg) chassis
--	--

Acoustic Sound (BlackDiamond 12804 switch with AC Power Supplies)

Sound power in accordance with EN 300 753 (10-1997)	Sound power Normal: 70 dBA per ISO 7779 High: 73 dBA per ISO 7779 Declared sound power Normal: 7.2 belsA per ISO 7779 & ISO 9296 High: 7.6 belsA per ISO 7779 & ISO 9296
Sound pressure in accordance with NEBS GR-63 Issue 2	Bystander sound pressure Normal: 64 dBA front side @ 0.6m High: 66 dBA left side @ 0.6m

BlackDiamond 12802 Switch

Table 25: BlackDiamond 12802 Switch Technical Specifications**Physical Dimensions**

BlackDiamond 12802 chassis	Height: 5.25 inches (13.3 cm) Width: 17.25 inches (43.8 cm) Depth: 21.25 inches (54.0 cm)
----------------------------	---

Weight

BlackDiamond 12802 chassis (empty)	29.25 lb (13.3 kg)
BlackDiamond 12802 chassis (fully loaded)	63 lb (28.6 kg)
BlackDiamond 12802 power supply	3.0 lb (1.4 kg)
BlackDiamond 12802 fan tray	3.25 lb (1.5 kg)
BlackDiamond 12802 PSU/Fan Controller	0.5 lb (0.2 kg)

Table 25: BlackDiamond 12802 Switch Technical Specifications (Continued)

Safety Standards

North American Safety of ITE	UL 60950-1:2003 1st Ed., Listed Device (US) CSA 22.2#60950-1-03 1st Ed.(Canada) Complies with FCC 21CFR 1040.10 (US Laser Safety) CDRH Letter of Approval (US FDA Approval) NOM/NYCE (Mexico) IEEE 802.3af 6-2003 Environment A for PoE Applications
European Safety of ITE	EN 60950-1:2001+A11 EN 60825-1+A2:2001 (Lasers Safety) TUV-R GS Mark by German Notified Body 73/23/EEC Low Voltage Directive
International Safety of ITE	CB Report & Certificate per IEC 60950-1:2001 Country Deviations AS/NZX 60950-1 (Australia /New Zealand)

EMI/EMC Standards

North America EMC for ITE	FCC CFR 47 part 15 Class A (USA) ICES-003 Class A (Canada)
European EMC standards	EN 55022:1998 Class A EN 55024:1998 Class A includes IEC 61000-4-2, 3, 4, 5, 6, 8, 11 EN 61000-3-2,3 (Harmonics & Flicker) ETSI EN 300 386:2001 (EMC Telecommunications) 89/336/EEC EMC Directive
International EMC certifications	CISPR 22:1997 Class A (International Emissions) CISPR 24:1997 Class A (International Immunity) IEC/EN 61000-4-2 Electrostatic Discharge, 8kV Contact, 15kV Air, Criteria A IEC/EN 61000-4-3 Radiated Immunity 10V/m, Criteria A IEC/EN 61000-4-4 Transient Burst, 1kV, Criteria A IEC/EN 61000-4-5 Surge, 2kV, 4kV, Criteria A IEC/EN 61000-4-6 Conducted Immunity, 0.15-80MHz, 10V/m unmod. RMS, Criteria A IEC/EN 61000-4-11 Power Dips & Interruptions, >30%, 25 periods, Criteria C
Country-specific	VCCI Class A (Japan Emissions) AS/NZS 3548 ACA (Australia Emissions) CNS 13438:1997 Class A (BSMI-Taiwan) MIC Mark, EMC Approval (North Korea)

Telecom Standards

ETSI EN 300 386:2001 (EMC Telecommunications)
ETSI EN 300 019 (Environmental for Telecommunications)

IEEE 802.3 Media Access Standards

Note: These standards are module-specific and may not apply to every module in the series.

IEEE 802.3 10BASE-T
IEEE 802.3u 100BASE-TX, 100BASE-FX
IEEE 802.3z 1000BASE-X
IEEE 802.3ab 1000BASE-T
IEEE 802.3ac VLAN Tag
IEEE 802.3ad Link Aggregation
IEEE 802.3ae 10GBASE-X
IEEE 802.3aef Power over Ethernet

Environmental Standards

Environmental	EN/ETSI 300 019-2-1 v2.1.2 - Class 1.2 Storage EN/ETSI 300 019-2-2 v2.1.2 - Class 2.3 Transportation EN/ETSI 300 019-2-3 v2.1.2 - Class 3.1e Operational EN/ETSI 300 753 (1997-10) - Acoustic Noise
---------------	--

Table 25: BlackDiamond 12802 Switch Technical Specifications (Continued)

Operating conditions	Operating temperature range 0° C to 40° C (32° F to 104° F) Operating humidity: 10% to 93% relative humidity, non-condensing Operating altitude 0 to 3000 meters (0 to 9,850 ft) Operational shock: 30 m/s ² (3 g), 11 ms, 60 shocks Operational random vibration: 5 to 500 Hz @ 1.5g rms
Storage & transportation conditions (packaged)	Transportation temperature: -40° C to 70° C (-40° F to 158° F) Storage and transportation humidity: 10% to 93% relative humidity, non-condensing Packaged shock (half sine): <50 kg 180 m/s ² (10 g), 6 ms, 600 shocks, modules >50 kg 100 m/s ² (6 g), 11 ms, 600 shocks, chassis Packaged random vibration: 5 to 20 Hz @ 1.0 ASD w/-3dB/oct. from 20 to 200 Hz Packaged sinusoidal vibration: 5 to 62 Hz, 5 mm/s velocity, 62 to 200 Hz, 0.2 G Tilt: 22.5 degrees and return to position 14 drops minimum on sides & corners @ 39.4" <20 lb (9 kg) modules @ 19.7" <80 lb (36 kg) chassis

Power Supplies for the BlackDiamond 12800 Series Switches

This section lists specifications for the power supplies that are installed in the following BlackDiamond switches:

- BlackDiamond 12804 switch
- BlackDiamond 12802 switch

Table 26: AC SSI PS Model #60020/PS2336 (700/1200 W AC PSU)

For the BlackDiamond 12804 switch	
Typical configuration	3 power supplies
Full configuration	6 power supplies
Input	Nominal input: 100 to 240 V ~, 60/50 Hz, 10 A max AC voltage input range: 90 to 264 V ~ Maximum input amperages: 7 A @ 200 V ~ (high-line) 10 A @ 90 V ~ (low-line) AC line frequency: 47 to 63 Hz PS input socket: IEC 320 C14 Minimum wire size: 16 AWG (1.31mm ²) copper stranded
Output	DC output: 48 V =, 24 A/12 V =, 4 A (high-line) 48 V =, 13.5 A/12 V =, 4 A (low-line) DC output power (W): 700 to 1200 W
Power supply cord selection	Refer to “Selecting Power Supply Cords” on page 136.
AC power supply input socket	IEC 320 C14
Minimum wire size	16 AWG (1.0mm ²) copper stranded (pre-approved cord set for county of use)
Operating conditions	Operating temperature: 0° C to 40° C Storage temperature: -40° C to 70° C Operating humidity: 10% to 90% relative humidity, non-condensing Operational shock: 30 m/s ² (3 g)

Table 27: DC SSI PS Model #60021 (1200 W DC PSU)

For the BlackDiamond 12804 switch

Typical configuration	3 power supplies
Full configuration	6 power supplies
Input	<p>Nominal input voltage: -48 V \equiv</p> <p>Voltage input range: -40.5 V \equiv to -72 V \equiv</p> <p>Input currents:</p> <ul style="list-style-type: none"> -40 V \equiv @ 35 A -48 V \equiv @ 30 A -60 V \equiv @ 23 A <p>Maximum in-rush current: Not more than 80 A for 5 ms</p> <p>Input circuit protection: 50 A</p> <p>Wire harness provided by Extreme Networks with each power supply. Extreme Part# 4340-00028 Wire type: 8 AWG (10 mm²) listed tray cable, copper-stranded rated @ 90 C minimum Connector: Molex connector PN 42816-0312 Connector pins: Molex connector pins PN 42815-0032</p>
Output	<p>DC output: 48 V \equiv , 24 A / 12 V \equiv , 4 A</p> <p>DC output power (W): 1200 W</p>
Operating conditions	<p>Operating temperature: 0° C to 40° C (32° F to 104 °F)</p> <p>Operating humidity: 10% to 90% relative humidity, non-condensing</p> <p>Operating altitude: 0 m to 3,000 m (0 ft to 9,850 ft)</p> <p>Operational shock*: 30 m/s² (3 g), 60 shocks</p> <p>Operational office vibration*: 5 to 100-5 Hz @ 2/10 G, 0 to peak, 1 oct/min</p> <p>Operational random vibration*: 3 to 500 Hz @ 1.5 G rms</p> <p>* Worst case operational condition; not for continuous operation under this condition</p>

Table 28: AC PS Model #65021 (325 W AC Power Supply)

For the BlackDiamond 12802 switch

Minimum configuration	2 power supplies
Full configuration	4 power supplies
Input	<p>Nominal input ratings: 100 to 240 V \sim , 60/50 Hz, 4 A max</p> <p>Operational voltage range: 90 to 264 V \sim</p> <p>Maximum input amperages:</p> <ul style="list-style-type: none"> 3.5 A @ 115 V \sim (low-line) 1.75 A @ 230 V \sim (high-line) <p>AC line frequency: 47 to 63 Hz</p> <p>AC power supply input socket: IEC 320 C14</p> <p>Minimum wire size: 18 AWG (0.82mm²) copper stranded (pre-approved cord set for county of use)</p>
Output	<p>DC Output:</p> <ul style="list-style-type: none"> 48 V \equiv , 6 A/12 V \equiv 2.5 A/7 VSB 0.75 A <p>Output power (W): 325 W</p>
Operating conditions	<p>Operating temperature: 0° C to 40° C</p> <p>Storage temperature: -40° C to 70° C</p> <p>Operating humidity: 10% to 90% relative humidity, non-condensing</p> <p>Operational shock: 30 m/s² (3 g)</p>

Table 29: DC PS Model #65022 (325 W DC PSU)

For the BlackDiamond 12802 switch

Minimum configuration	2 power supplies
Full configuration	4 power supplies
Input	<p>Nominal input voltage: $-48\text{ V} \sim$, $-60\text{ V} \sim$, 15 A maximum</p> <p>Operational voltage range: -40 V to $-72\text{ V} \sim$</p> <p>Maximum input amperages:</p> <ul style="list-style-type: none"> 10 A @ $-40\text{ V} \sim$ (low-line) 8 A @ $-48\text{ V} \sim$ 7 A @ $-60\text{ V} \sim$ (high-line) <p>Maximum in-rush current: 8 A</p> <p>Input circuit protection: 15 A</p> <p>Wire harness provided by Extreme Networks with each power supply.</p> <p>Extreme part number 4340-00028</p> <p>Minimum wire size: 14 AWG (1.3 mm²) copper stranded (pre-approved cord set for county of use)</p> <p>Connector: Molex connector PN 42816-0312</p> <p>Connector pins: Molex connector pins PN 42815-0032</p>
Output	<p>DC Output:</p> <ul style="list-style-type: none"> 48 V \equiv, 6 A/ 12 V \equiv 2.5 A/7 VSB 0.75 A <p>Output power (W): 325 W</p>
Operating conditions	<p>Operating temperature: 0° C to 40° C</p> <p>Storage temperature: -40° C to 70° C</p> <p>Operating humidity: 10% to 90% relative humidity, non-condensing</p> <p>Operational shock: 30 m/s² (3 g)</p>

Connector Pinouts

Table 30 describes the pinouts for a DB-9 console plug connector.

Table 30: Pinouts for the DB-9 Console Connector

Function	Pin Number	Direction
DCD (data carrier detect)	1	In
RXD (receive data)	2	In
TXD (transmit data)	3	Out
DTR (data terminal ready)	4	Out
GND (ground)	5	-
DSR (data set ready)	6	In
RTS (request to send)	7	Out
CTS (clear to send)	8	In

Figure 87 shows the pinouts for a 9-pin to 25-pin (RS-232) null-modem cable.

Figure 87: Null-modem Cable Pinouts

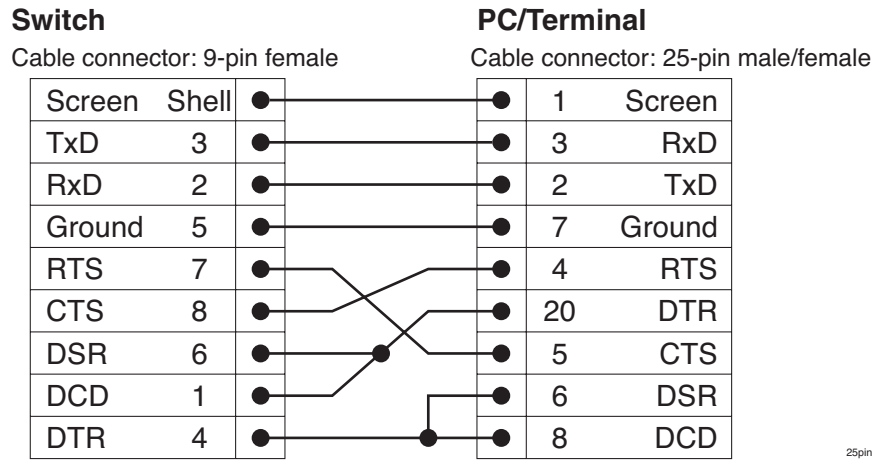
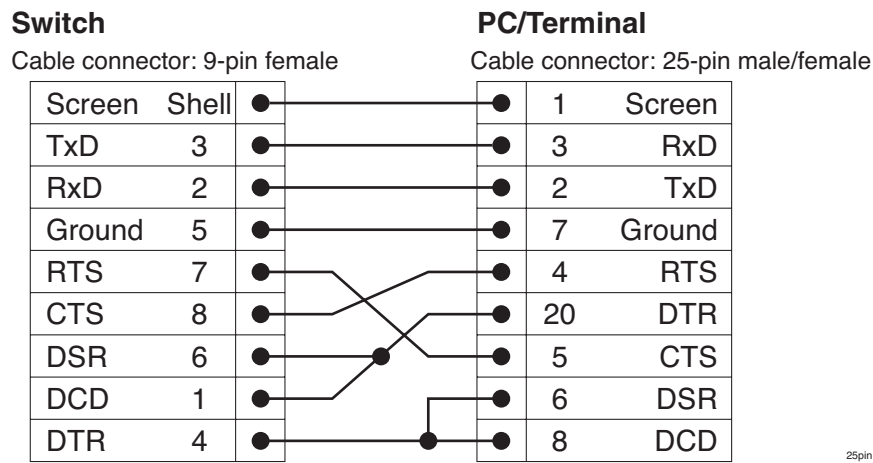

Figure 88 shows the pinouts for a 9-pin to 9-pin (PC-AT) null-modem serial cable.

Figure 88: PC-AT Serial Null-modem Cable Pinouts



Numerics

- 1200 W DC PSU
 - description, 30, 74
 - installing, 76
 - LEDs, 31, 80
 - removing, 79
 - specifications, 152
- 325 W AC PSU
 - description, 36, 94
 - installing, 95
 - LEDs, 37, 99
 - removing, 99
 - specifications, 152
- 325 W DC PSU
 - description, 34, 88
 - installing, 90
 - LEDs, 35, 94
 - removing, 93
 - specifications, 153
- 700/1200 W AC PSU
 - description, 32, 81
 - installing, 81
 - LEDs, 33, 84
 - removing, 83
 - specifications, 151

A

- AC power cord retainer channel
 - installing, 85
 - removing, 88
- AC power cord retaining bracket on 325 W AC PSU, 97
- airflow, 44
- airflow requirements, 44
- amperage, calculating for UPS, 55
- ANSI standards, 55

B

- backup MSM, 21
- bend radius
 - fiber optic cable, 50
 - UTP cable, 49
- BICSI standards, 48
- BlackDiamond 12800 series switch
 - features, 15

- MSM, 20
- BlackDiamond 12802 switch
 - features, 18
 - installing
 - mid-mount, 67
 - installing, front-mount, 66
 - MAC address, 18
 - repacking, 129
 - serial number, 18
 - specifications, 149
 - unpacking, 64
- BlackDiamond 12804 switch
 - AC power cord retainer channel
 - installing, 85
 - removing, 88
 - attaching mid-mount brackets, 61
 - features, 16
 - installing, 60
 - PSU fan controller, replacing, 116
 - rack mounting, 62
 - repacking, 126
 - replacing fan tray, 121
 - serial number, 17
 - specifications, 147
 - unpacking, 58
- blank front panels, 108
- building codes, 42
- Building Industry Consulting Service International. *See* BICSI
- bundling cable, 49

C

- cable connections, making, 105
- cable identification records, 48
- cable labeling, 48
- cable types and distances, 51
- cable, category 5, 49
- cable, installing
 - bend radius
 - fiber optic, 50
 - UTP, 49
 - distances, 51
 - fiber optic cable, 50
 - recommendations, 49
 - slack, 49
- cabling standards
 - ANSI, 55

- BICSI, 48
- category 5 cable, 49
- chassis-to-chassis heating, 44
- commands
 - eject memory card, 111
 - show memorycard, 111
 - show slot, 106
 - synchronize, 105
- commercial building standards, 55
- compact flash. *See* external memory card
- components, installing
 - backup MSM, 105
 - BlackDiamond 12802 switch
 - fan tray, 123
 - PSU/fan controller, 119
 - BlackDiamond 12804 switch
 - fan tray, 121
 - PSU/fan controller, 117
- blank front panel, 108
- external memory card, 111
- components, removing
 - BlackDiamond 12802 switch
 - fan tray, 122
 - PSU/fan controller, 118
 - BlackDiamond 12804 switch
 - fan tray, 120
 - PSU/fan controller, 116
- external memory card, 111
- modules, 107
- console port
 - on MSM, 22
 - settings, 70
- conventions
 - notice icons, 10
 - text, 10

D

- DB-9 pinouts, 153
- DC wiring, installing, 75, 89
- design standards, 55

E

- electrical codes, 42
- electrostatic discharge. *See* ESD
- environmental requirements
 - airflow, 44
 - building codes, 42
 - electrical codes, 42
 - humidity, 44
 - switch spacing, 44
 - temperature, 43
 - wiring closet, 43

- equipment rack
 - grounding, 46
 - mechanical recommendations, 46
 - mounting holes, 46
 - securing, 47
 - service access, 47
 - space requirements, 47

ESD

- discharge from cable, 49
- system protection, 45
- ESD-preventive wrist strap, 45
- external compact flash slot, 23
- external memory card
 - installing, 111
 - uses of, 16

F

- fan tray
 - BlackDiamond 12802 switch
 - installing, 123
 - removing, 122
 - BlackDiamond 12804 switch
 - installing, 121
 - removing, 120
- fiber optic cable
 - bend radius, 50
 - care, 50
 - connections, making, 105
- first switch login, 71
- full-duplex operation, 15
- fuse
 - 325 W AC power supply, 38
 - 325 W DC power supply, 36
 - 700/1200 W AC power supply, 33

G

- GM-20T module, 25
- GM-20XT module, 25
- GM-20XTR module, 25, 26
- grounding
 - chassis, 68
 - racks, 46
 - requirements, 55
 - wiring closet, 43
- grounding terminals, location, 46

H

- heating, chassis-to-chassis, 44
- helper bracket for BlackDiamond 12804 switch, 62
- high-line power, 34

hot-swapping modules, 107
 humidity, 44

I

I/O modules
 GM-20T module, 25
 GM-20XT module, 25
 GM-20XTR module, 26
 hot-swapping, 107
 LEDs, 24
 removing, 107
 verifying installation, 106
 XM-2HR module, 28
 XM-2X module, 26
 XM-2XR module, 26
 I/O port LEDs, 24
 industry standards, 55
 initial switch login, 71
 installation
 1200 W DC power supply, 76
 325 W AC power supply, 95
 325 W DC power supply, 90
 700/100 W AC power supply, 81
 AC power cord retaining bracket, 97
 BlackDiamond 12802 chassis
 front-mount, 66
 BlackDiamond 12804 chassis, 60
 blank front panels, 108
 DC wiring for 1200 W DC power supply, 75
 DC wiring for 325 W DC power supply, 89
 modules, 102
 installing modules, 102
 installing PSU/fan controller
 BlackDiamond 12802, 119
 BlackDiamond 12804, 117
 IP settings, configuring, 71

L

labeling system for cables, 48
 LEDs
 I/O modules, 24
 MSM, 21
 ports, 24
 logging in to the switch, 71
 low-line power, 34

M

MAC address
 BlackDiamond 12802 switch, 18
 BlackDiamond 12804 switch, 17
 management modules

MSM-5, 22
 MSM-5R, 22
 MSM-6R, 22
 management port
 description, 16
 location, 22
 memory card. *See* external memory card
 mid-mount installation
 BlackDiamond 12802 switch, 67
 BlackDiamond 12804 switch, 61
 modules
 distinguishing MSM from I/O, 102
 hot-swapping, 107
 injector/ejector handles, 103
 installing, 101, 102
 overview, 19
 MSM
 booting, 21
 console port, 22
 dual MSMs, 21
 external compact flash slot, 23
 hot-swapping, 107
 installation verification, 106
 LEDs, 21
 management port, 22
 primary, backup functionality, 21
 redundant, 21
 removing, 107
 resetting, 23
 saving configurations, 21
 MSM-5 module, 22
 MSM-5R module, 22
 MSM-6R module, 22

N

network interface connections, 105
 null-modem cable pinouts, 154

O

operating environment requirements, 42
 over-current conditions, preventing, 34, 36, 85, 94

P

PC-AT serial null-modem cable pinouts, 154
 pinouts
 DB-9 console connector, 153
 null-modem cable, 154
 PC-AT serial null-modem cable, 154
 plenum-rated cable, 49
 ports

- console, 22
- console port settings, 70
- management, 16, 22
- power cable, replacing, 54
- power requirements
 - power cable, 54
 - power supplies, 53
- power supplies
 - 1200 W DC, 76
 - 325 W AC, 95
 - 325 W DC, 90
 - 700/1200 W AC, 81
 - power requirements, 53
- power supply unit (PSU)
 - 1200 W DC PSU, 30, 74
 - 325 W AC PSU, 36
 - 325 W DC PSU, 34
 - 700/1200 W AC PSU, 32, 81
- primary MSM, 21
- PSU/fan controller
 - BlackDiamond 12802 switch
 - installing, 119
 - removing, 118
 - BlackDiamond 12804 switch
 - installing, 117
 - removing, 116
 - installing
 - BlackDiamond 12802, 119
 - BlackDiamond 12804, 117
 - removing, 116, 118

R

- rack installation
 - BlackDiamond 12802 switch, 66, 67
 - BlackDiamond 12804 switch, 62
- rack specifications
 - grounding, 46
 - mechanical recommendations, 46
 - mounting holes, 46
 - securing to floor, 47
 - space requirements, 47
 - standards, 46
- radio frequency interference. *See* RF interference
- redundant MSM, 21
- redundant MSM activity, 21
- related publications, 10
- removing spare PSU/Fan controller, 116, 118
- requirements, spacing, 44
- reset button, 23
- resetting MSM, 23
- retaining bracket, power cord, on 325 W AC PSU, 97
- RF interference

- patch panel installation, 49
- preventing, 53
- problems caused by, 53
- RJ-45 cable, 52
- RJ-45 connector jackets, 52
- routing cable, 49

S

- safety requirements. *See* environmental requirements
- securing the rack, 47
- selecting a UPS, 55
- serial number
 - BlackDiamond 12802 switch, 18
 - BlackDiamond 12804 switch, 17
- service access to the rack, 47
- site planning process, 41
- slot information, displaying, 106
- slots, unoccupied, 108
- space requirements, rack, 47
- specifications
 - 1200 W DC PSU, 152
 - 325 W AC PSU, 152
 - 325 W DC PSU, 153
 - 700/1200 W AC PSU, 151
 - BlackDiamond 12802 switch, 149
 - BlackDiamond 12804 switch, 147
 - power cable, 54
- standards
 - cabling, 48, 55
 - commercial building, 55
 - grounding, 55
- switch configuration, saving, 21
- switch spacing requirements, 44
- switch, initial login, 71

T

- technical specifications
 - 1200 W DC PSU, 152
 - 325 W AC PSU, 152
 - 325 W DC PSU, 153
 - 700/1200 W AC PSU, 151
 - BlackDiamond 12802 switch, 149
 - BlackDiamond 12804 switch, 147
- temperature, wiring closet, 43
- text conventions, 10
- tools for installing equipment
 - blank front panels, 108
 - external memory card, 111
 - fan tray, BlackDiamond 12802 switch, 122
 - fan tray, BlackDiamond 12804 switch, 119
- transition time, 55

- transition time, UPS, 55
- troubleshooting
 - external memory card, installing, 111
 - over-current conditions, 34, 36, 85, 94
 - power, turning off, 34, 36, 85
 - RF interference, 53

U

- unshielded twisted pair. *See* UTP
- UPS (uninterruptible power supply), 54
- UTP cable
 - bend radius, 49
 - category 5, 49
 - discharge ESD, 49
 - RF interference, 53

W

- wiring closet
 - airflow requirements, 44
 - electrostatic discharge, 45
 - floor coverings, 43
 - grounding, 43
 - humidity, 44
 - rack, securing, 47
 - temperature, 43
- wiring terminals, 46

X

- XM-2HR module, 28
- XM-2X module, 26
- XM-2XR module, 26

