

## 24.66 FLIR T660 45° (incl. Wi-Fi)

P/N: 55904-8622

Rev.: 43545

General description	
<p>The FLIR T660 is designed for the expert requiring the highest performance and the latest technology available. The camera combines excellent ergonomics and a walk-up-and-use interface with superior image quality of 640 × 480 pixel infrared resolution. The FLIR T660 is flexible and can meet your every need.</p>	
Benefits:	
<ul style="list-style-type: none"> <li>• Highest performance with the latest technology: The FLIR T660 is equipped with the innovative Multi Spectral Dynamic Imaging (MSX) feature, which produces an image richer in detail than ever before. Continuous auto-focus makes the FLIR T660 the first fully automatic infrared camera on the market.</li> <li>• Ground-breaking efficiency: You can highlight objects of interest, on both the infrared and the visual images, by sketching or adding predefined stamps directly onto the camera's capacitive touch screen. The user interface is intuitive and logical for effective operation. Auto-orientation allows you to tilt between landscape and portrait views.</li> <li>• Extensive communication options: The Wi-Fi connectivity of the FLIR T660 allows you to connect to smart phones or tablets for the wireless transfer of images or the remote control of the camera. The Bluetooth-based METERLiNK function transfers readings from external measurement instruments to the infrared image.</li> <li>• Support for UltraMax: When enabling UltraMax in the camera, the resolution of images can be substantially enhanced when importing the images into FLIR Tools.</li> </ul>	
Imaging and optical data	
IR resolution	640 × 480 pixels
UltraMax	Yes
Thermal sensitivity/NETD	<20 mK @ +30°C (+86°F)
Field of view (FOV)	45° × 34°
Minimum focus distance	0.15 m (0.49 ft.)
Focal length	13 mm (0.52 in.)
Spatial resolution (IFOV)	1.30 mrad
Lens identification	Automatic
F-number	1.0
Image frequency	30 Hz
Focus	Continuous, one shot or manual
Digital zoom	1–8× continuous
Digital image enhancement	Adaptive digital noise reduction
Detector data	
Detector type	Focal plane array (FPA), uncooled microbolometer
Spectral range	7.5–14 μm
Detector pitch	17 μm
Image presentation	
Display	Built-in touch screen, 4.3 in. wide screen LCD, 800 × 480 pixels
Display type	Capacitive touch screen
Auto orientation	Automatic landscape or portrait
Viewfinder	Built-in 800 × 480 pixels

<b>Image presentation</b>	
Automatic image adjustment	Continuous, histogram based
Manual image adjustment	Linear based; possible to adjust level/span/max./min.
<b>Image presentation modes</b>	
Infrared image	Full-color IR image
Visual image	Full color visual image
Thermal MSX	Thermal image with enhanced detail presentation
Picture in Picture	Resizable and movable IR area on visual image
<b>Measurement</b>	
Object temperature range	<ul style="list-style-type: none"> <li>• <math>-40^{\circ}\text{C}</math> to <math>+150^{\circ}\text{C}</math> (<math>-40^{\circ}\text{F}</math> to <math>+302^{\circ}\text{F}</math>)</li> <li>• <math>+100^{\circ}\text{C}</math> to <math>+650^{\circ}\text{C}</math> (<math>+212^{\circ}\text{F}</math> to <math>+1202^{\circ}\text{F}</math>)</li> <li>• <math>+300^{\circ}\text{C}</math> to <math>+2000^{\circ}\text{C}</math> (<math>+572^{\circ}\text{F}</math> to <math>+3632^{\circ}\text{F}</math>)</li> </ul>
Accuracy	<ul style="list-style-type: none"> <li>• <math>\pm 1^{\circ}\text{C}</math> (<math>\pm 1.8^{\circ}\text{F}</math>) or <math>\pm 1\%</math> of reading for limited temperature range.</li> <li>• <math>\pm 2^{\circ}\text{C}</math> (<math>\pm 3.6^{\circ}\text{F}</math>) or <math>2\%</math>, whichever is greater, at <math>25^{\circ}\text{C}</math> (<math>77^{\circ}\text{F}</math>) nominal.</li> </ul>
<b>Measurement analysis</b>	
Spotmeter	10
Area	5 + 5 areas (boxes or circles) with max./min./average (in post-acquisition analysis)
Profile	1 line profile with max/min temp
Automatic hot/cold detection	Auto hot or cold spotmeter markers within area and profile
Measurement presets	No measurements, Center spot, Hot spot, Cold spot, User preset 1, User preset 2
User presets (in live images)	The user can select and combine measurements from any number of available spots/boxes/circles/profiles/delta
Difference temperature	Delta temperature between measurement functions or reference temperature
Reference temperature	Manually set using difference temperature
Atmospheric transmission correction	Automatic, based on inputs for distance, atmospheric temperature and relative humidity
Optics transmission correction	Automatic, based on signals from internal sensors
Emissivity correction	Variable from 0.01 to 1.0 or selected from materials list
Emissivity table	Emissivity table of predefined materials
Reflected apparent temperature correction	Automatic, based on input of reflected temperature
External optics/windows correction	Automatic, based on inputs of window transmission and temperature
Measurement corrections	Emissivity, reflected temperature, relative humidity, atmospheric temperature, object distance, external IR window compensation
Colors (palettes)	Iron, Rainbow, Rainbow HC, White hot, Black hot, Arctic, Lava

<b>Alarm</b>	
Color Alarm (isotherm)	Above/below/interval
Measurement function alarm	Audible/visual alarms (above/below) on any selected measurement function
Screening	Difference temperature alarm, audible
<b>Set-up</b>	
Set-up commands	Define user presets, Save options, Programmable button, Reset options, Set up camera, Wi-Fi, GPS & compass, Bluetooth, Language, Time & units, Camera information
<b>Service functions</b>	
Camera software update	Use PC software FLIR Tools
<b>Storage of images</b>	
Image storage	Standard JPEG, including digital photo and measurement data, on memory card
Storage media	Removable memory SD card
Image storage mode	<ul style="list-style-type: none"> <li>• Simultaneous storage of thermal and digital photo in same JPEG file.</li> <li>• Optional to store digital photo as a separate JPEG file.</li> </ul>
Time lapse	15 seconds to 24 hours
File formats	Standard JPEG, measurement data included
File formats, visual	Standard JPEG, automatically associated with corresponding thermal image
<b>Image annotations (in still images)</b>	
Voice	60 seconds (via Bluetooth) stored with the image
Text	Add table. Select between predefined templates or create your own in FLIR Tools
Image description	Add short note (stored in JPEG EXIF tag)
Sketch	Draw on thermal/digital photo or add predefined stamps
METERLiNK	Wireless connection (Bluetooth) to: FLIR meters with METERLiNK
Report generation	<ul style="list-style-type: none"> <li>• Instant Report (*.pdf file) in camera</li> <li>• Separate PC software with extensive report generation</li> </ul>
<b>Geographic Information System</b>	
GPS	Location data automatically added to every still image from built-in GPS
Compass	Camera direction automatically added to every still image
<b>Video recording in camera</b>	
Radiometric IR video recording	CSQ to memory card
Non-radiometric IR video recording	MPEG-4 to memory card
Visual video recording	MPEG-4 to memory card

<b>Video streaming</b>	
Radiometric IR video streaming	Full dynamic to PC using USB or to mobile devices using Wi-Fi.
Non-radiometric IR video streaming	<ul style="list-style-type: none"> <li>• MPEG-4 using Wi-Fi</li> <li>• Uncompressed colorized video using USB</li> </ul>
Visual video streaming	<ul style="list-style-type: none"> <li>• MPEG-4 using Wi-Fi</li> <li>• Uncompressed colorized video using USB</li> </ul>
<b>Digital camera</b>	
Built-in digital camera	5 Mpixels with LED light (photo as separate image)
Digital camera, FOV	Adapts to the IR lens
Video lamp	Built-in LED light
<b>Laser pointer</b>	
Laser	Activated by dedicated button
Laser alignment	Position is automatic displayed on the IR image
Laser classification	Class 2
Laser type	Semiconductor AlGaInP diode laser, 1 mW, 635 nm (red)
<b>Data communication interfaces</b>	
Interfaces	USB-mini, USB-A, Bluetooth, Wi-Fi, Digital Video Output
METERLiNK/Bluetooth	Communication with headset and external sensors
Wi-Fi	Peer to peer (ad hoc) or infrastructure (network)
SD Card	One card slot for removable SD memory cards
<b>USB</b>	
USB	<ul style="list-style-type: none"> <li>• USB-A: Connect external USB device</li> <li>• USB Mini-B: Data transfer to and from PC / uncompressed colorized video</li> </ul>
USB, standard	USB 2.0 high speed
<b>Video output</b>	
Video out	Digital video output (DVI)
Video, connector type	HDMI compatible
<b>Radio</b>	
Wi-Fi	<ul style="list-style-type: none"> <li>• Standard: 802.11 b/g</li> <li>• Frequency range: 2412–2462 MHz</li> <li>• Max. output power: 15 dBm</li> </ul>
METERLiNK/Bluetooth	Frequency range: 2402–2480 MHz
Antenna	Internal
<b>Power system</b>	
Battery type	Rechargeable Li ion battery
Battery operating time	> 2.5 hours at 25°C (+68°F) and typical use
Charging system	In camera (AC adapter or 12 V from a vehicle) or 2-bay charger
Charging time	2.5 h to 90 % capacity, charging status indicated by LED's

<b>Power system</b>	
Charging temperature	0°C to +45°C (+32°F to +113°F)
External power operation	AC adapter 90–260 VAC, 50/60 Hz or 12 V from a vehicle (cable with standard plug, optional)
<b>Environmental data</b>	
Operating temperature range	–15°C to +50°C (+5°F to +122°F)
Storage temperature range	–40°C to +70°C (–40°F to +158°F)
Humidity (operating and storage)	IEC 60068-2-30/24 h 95% relative humidity +25°C to +40°C (+77°F to +104°F) / 2 cycles
EMC	<ul style="list-style-type: none"> <li>• ETSI EN 301 489-1 (radio)</li> <li>• ETSI EN 301 489-17</li> <li>• EN 61000-6-2 (Immunity)</li> <li>• EN 61000-6-3 (Emission)</li> <li>• FCC 47 CFR Part 15 Class B (Emission)</li> <li>• ICES-003</li> </ul>
Radio spectrum	<ul style="list-style-type: none"> <li>• ETSI EN 300 328</li> <li>• FCC Part 15.247</li> <li>• RSS-247 Issue 2</li> </ul>
Encapsulation	IP 54 (IEC 60529)
Shock	25 g (IEC 60068-2-27)
Vibration	2 g (IEC 60068-2-6)
Safety	EN/UL/CSA/PSE 60950-1
<b>Physical data</b>	
Weight	1.3 kg (2.87 lb.)
Camera size, excl. lens (L × W × H)	143 × 195 × 95 mm (5.6 × 7.7 × 3.7 in.)
Tripod mounting	UNC ¼"-20
Housing material	Magnesium
<b>Shipping information</b>	
Packaging, type	Cardboard box
List of contents	<ul style="list-style-type: none"> <li>• Infrared camera with lens</li> <li>• Battery (2 ea.)</li> <li>• Battery charger</li> <li>• Bluetooth headset</li> <li>• Calibration certificate</li> <li>• Printed documentation</li> <li>• HDMI-DVI cable</li> <li>• HDMI-HDMI cable</li> <li>• Hard transport case</li> <li>• Large eyecap</li> <li>• Lens cap</li> <li>• Memory card</li> <li>• Neck strap</li> <li>• Power supply, incl. multi-plugs</li> <li>• Tripod adapter</li> <li>• USB cable, Std A to Mini-B</li> </ul>
Packaging, weight	6.6 kg (14.6 lb.)
Packaging, size	495 × 192 × 370 mm (19.49 × 7.56 × 14.57 in.)
EAN-13	7332558008768
UPC-12	845188009281
Country of origin	Sweden

**Supplies & accessories:**

- T197914; IR lens, f=41.3 mm (15°) with case

- T197922; IR lens, f=24.6 mm (25°) with case
- T197915; IR lens, f=13.1 mm (45°) with case
- T198059; Close-up IR lens, 2.9× (50 μm) with case
- T198060; Close-up IR lens, 5.8× (100 μm) with case
- T198166; IR lens, f=88.9 mm (7°) with case and support for T6xx
- T198065; IR lens, f=6.5 mm (80°) with case
- T198066; Close-up IR lens, 1.5× (25 μm) with case
- T197896; High temperature option +300°C to 2000°C (+572°F to 3632°F)
- T910814; Power supply, incl. multi plugs
- T198126; Battery charger, incl. power supply with multi plugs T6xx
- T199406ACC; Battery Li-ion 3.7 V, 7.8 Ah, 29 Wh
- T911650ACC; Memory card SD Card 8 GB
- 1910423; USB cable Std A <-> Mini-B
- T198509; Cigarette lighter adapter kit, 12 VDC, 1.2 m/3.9 ft.
- T910930ACC; HDMI type C to DVI cable 1.5 m
- T910891ACC; HDMI type C to HDMI type A cable 1.5 m
- T198625ACC; Hard transport case
- T198495; Pouch
- T198497; Large eyecup
- T198498; Tripod Adapter
- T198499; Neck strap
- T197771ACC; Bluetooth Headset
- T911093; Tool belt
- 19250-100; IR Window 2 in
- 19251-100; IR Window 3 in.
- 19252-100; IR Window 4 in.
- 19250-200; SS IR Window 2 in.
- 19251-200; SS IR Window 3 in.
- 19252-200; SS IR Window 4 in.
- T198496; Stylus pen
- T198586; FLIR Reporter Professional (license only)
- T198584; FLIR Tools
- T198583; FLIR Tools+ (download card incl. license key)
- DSW-10000; FLIR IR Camera Player
- APP-10002; FLIR Tools Mobile (Android Application)
- APP-10004; FLIR Tools (MacOS Application)
- T199233; FLIR Atlas SDK for .NET
- T199234; FLIR Atlas SDK for MATLAB

[See next page]

# Camera housing

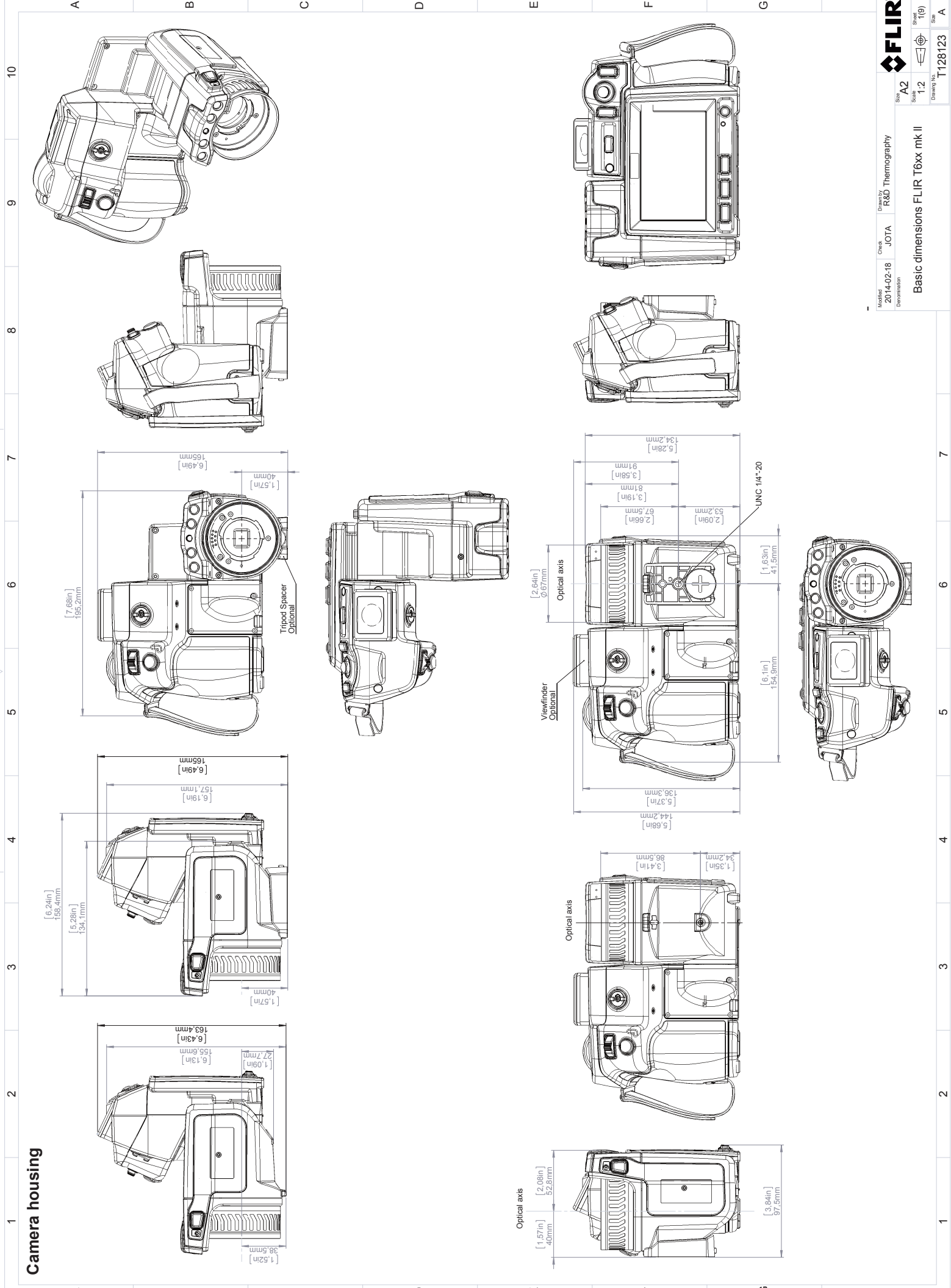

©2012 FLIR Systems, Inc. All rights reserved worldwide. No part of this drawing may be reproduced, stored in a retrieval system, or transmitted in any form, or by any means, electronic, mechanical, photocopying, recording, or otherwise, without written permission from FLIR Systems, Inc. Specifications subject to change without further notice. Dimensional data is based on nominal values. Products may be subject to regional market considerations. License procedures may apply. Product may be subject to US Export regulations. Please refer to exportquestions@flir.com with any questions. Diversion contrary to US law is prohibited.



# Camera with Lens IR f=6,5 mm (80°)

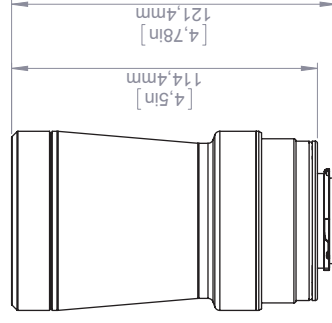
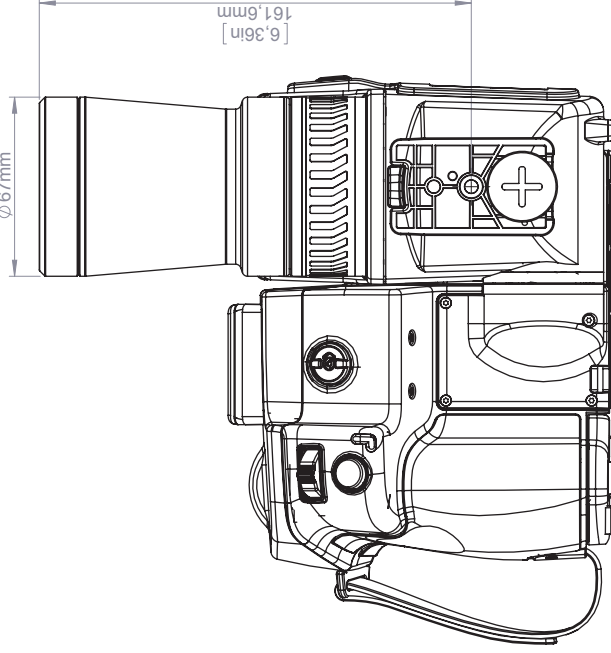
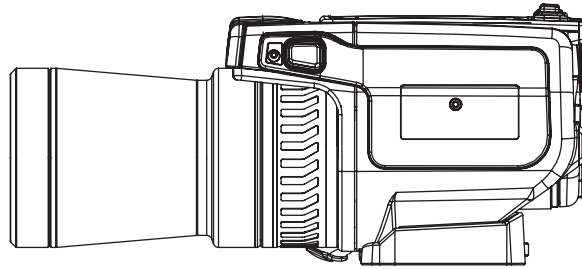
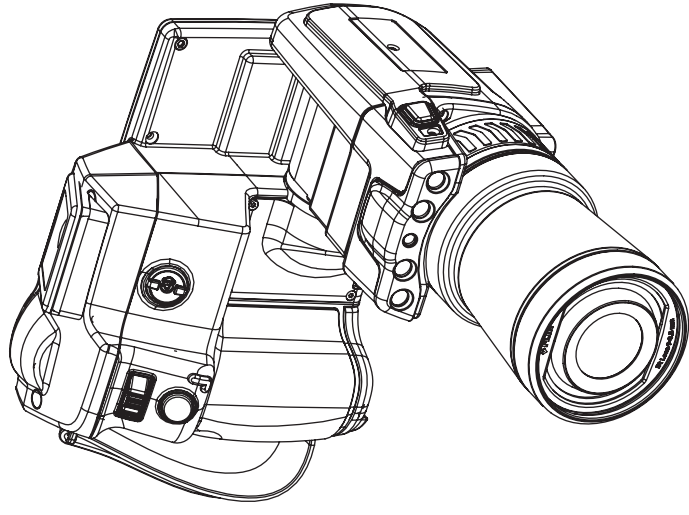
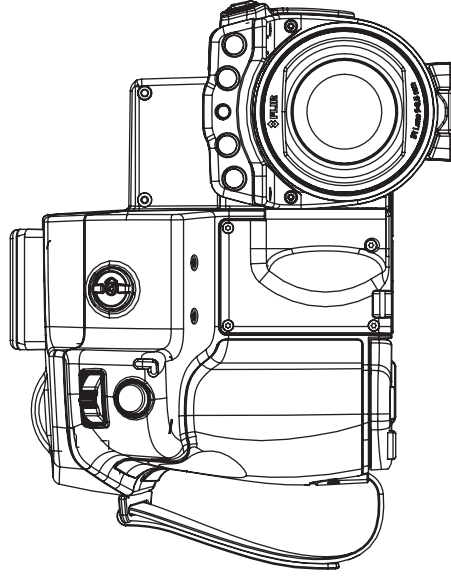
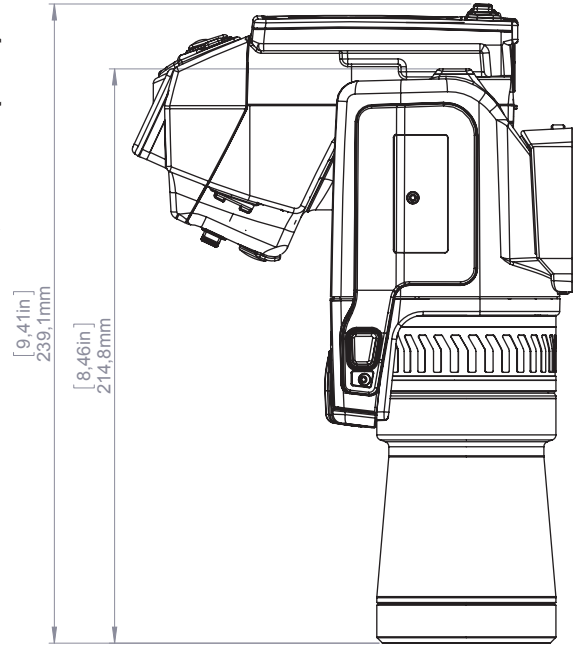

For additional dimensions see page 1

Modified 2014-02-18	Check JOTA	Drawn by R&D Thermography	Size A3	Sheet 2(9)	Size A
Denomination Basic dimensions FLIR T6xx mk II			Scale 1:2	Drawing No. T128123	

# Camera with Lens IR f=13,1 mm (45°)

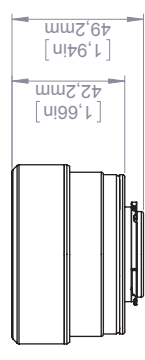
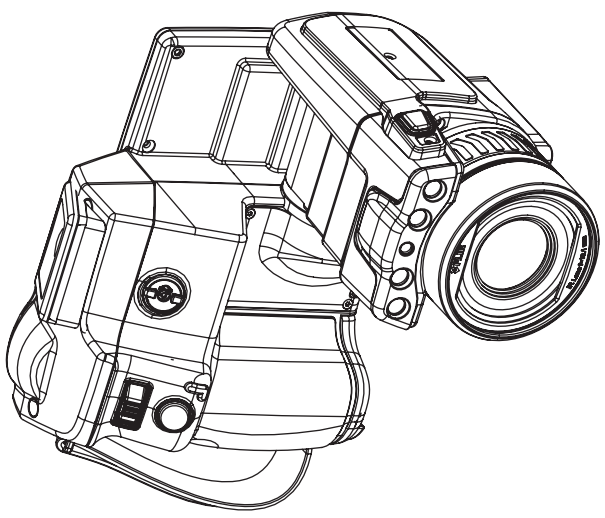
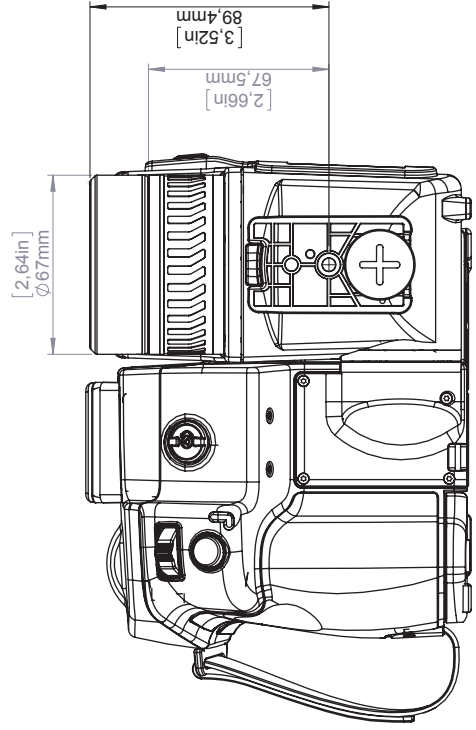
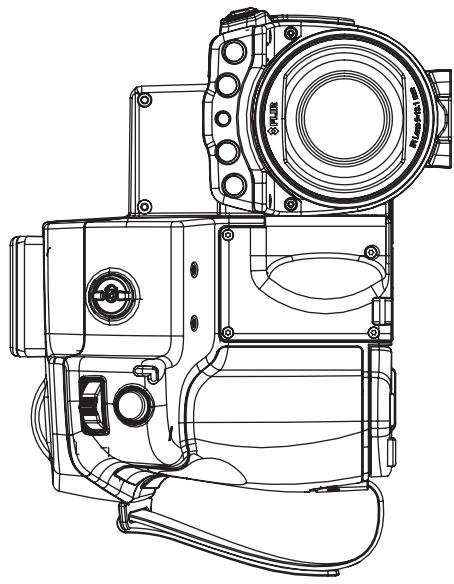
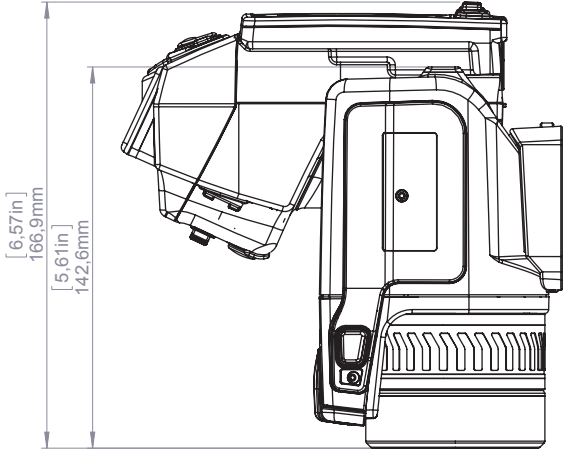

For additional dimensions see page 1			
Modified 2014-02-18 Denomination	Check JOTA	Drawn by R&D Thermography	Size A3
Basic dimensions FLIR T6xx mk II			Sheet 3(9)
			Scale 1:2
			Drawing No. T128123
			Size A

# Camera with Lens IR f=24,6 mm (25°)

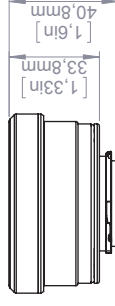
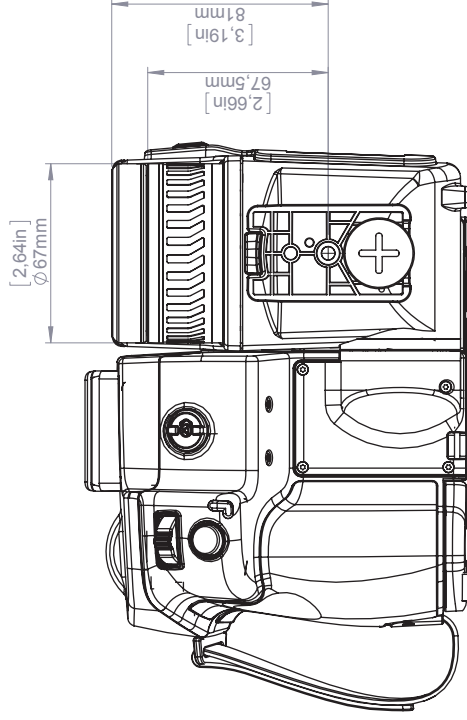
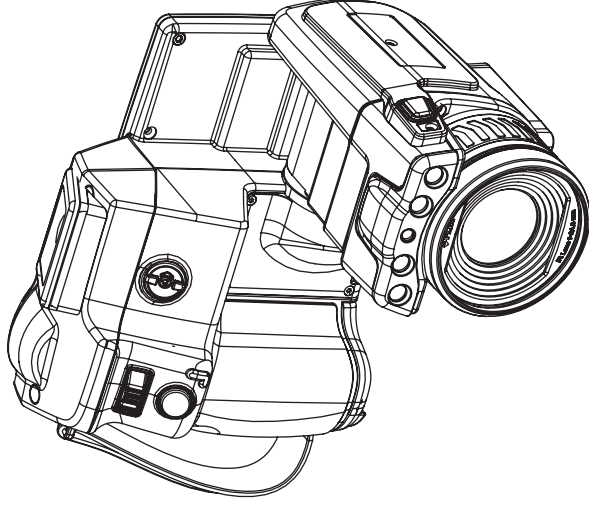
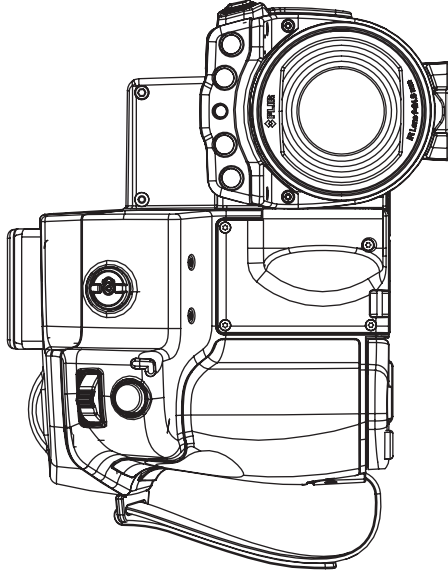
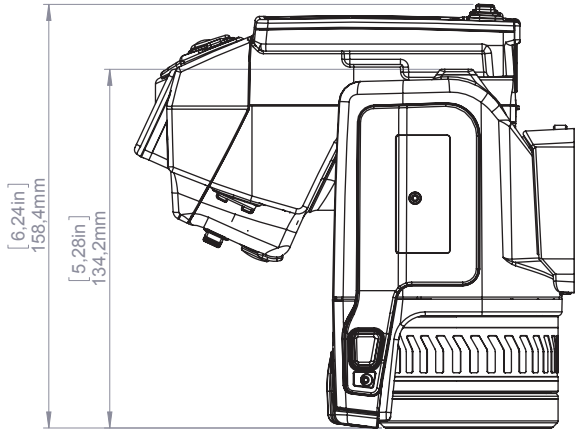

For additional dimensions see page 1

Modified 2014-02-18	Check JOTA	Drawn by R&D Thermography	FLIR®
Denomination Basic dimensions FLIR T6xx mk II			Sheet 4(9)
Size A3			Size A
Scale 1:2			Drawing No. T128123

# Camera with Lens IR f=41,3 mm (15°)

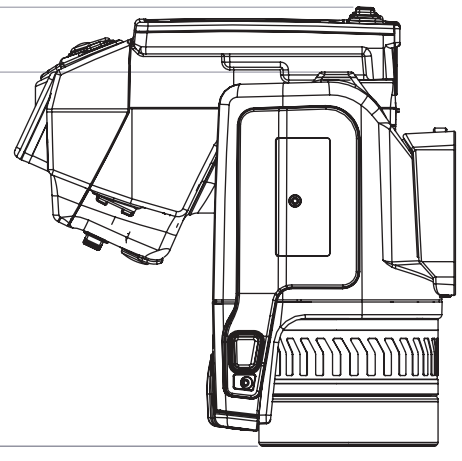
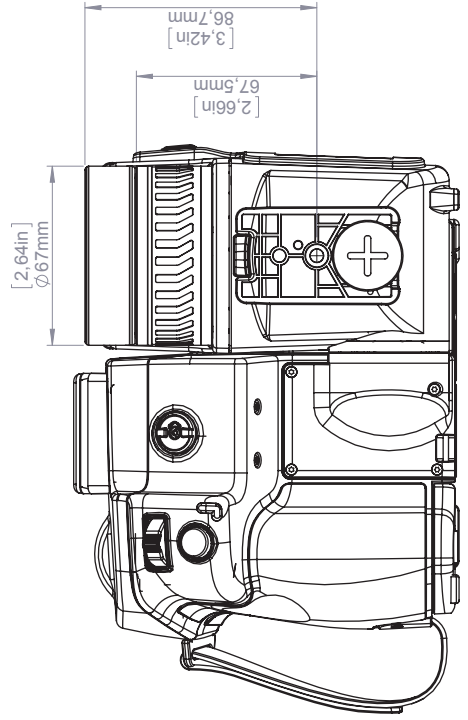
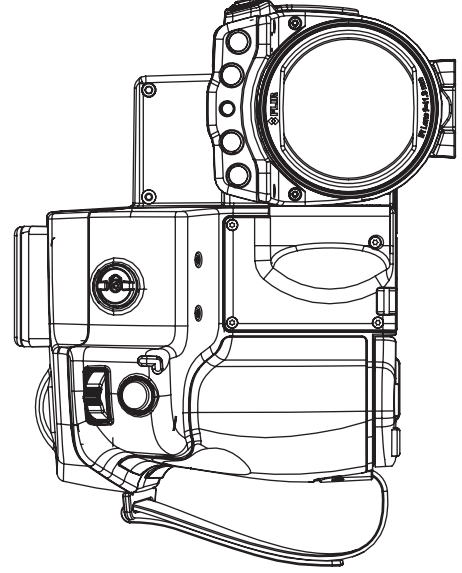
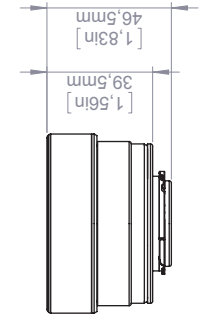
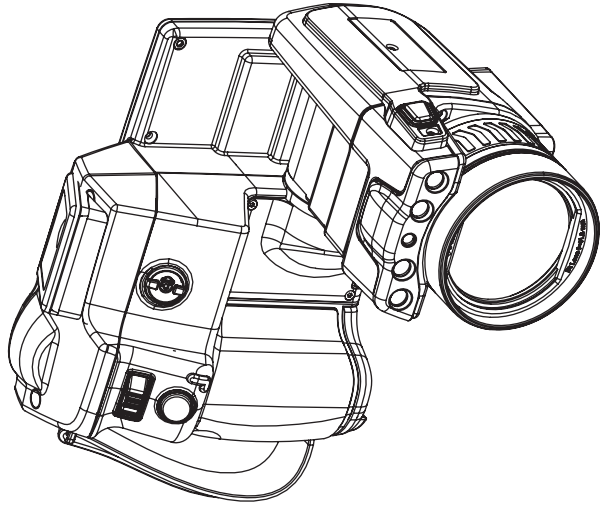

[6.47in]  
164.2mm  
[5.51in]  
139.9mm

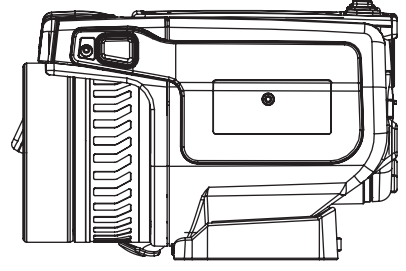

For additional dimensions see page 1			
Modified 2014-02-18 Denomination	Check JOTA	Drawn by R&D Thermography	FLIR®
Basic dimensions FLIR T6xx mk II			Sheet 5(9)
Size A3			Size A
Drawing No. T128123			Scale 1:2

Product may be subject to US Export Regulations. Please refer to exportquestions@flir.com with any questions. Diversion contrary to US law is prohibited. © 2012, FLIR Systems, Inc. All rights reserved worldwide. No part of this drawing may be reproduced, stored in a retrieval system, or transmitted in any form, or by any means, electronic, mechanical, photocopying, recording, or otherwise, without written permission from FLIR Systems, Inc. Specifications subject to change without further notice. Dimensional data is based on nominal values. Products may be subject to regional market considerations. License procedures may apply.

# Camera with Lens IR f=88,9 mm (7°) incl support

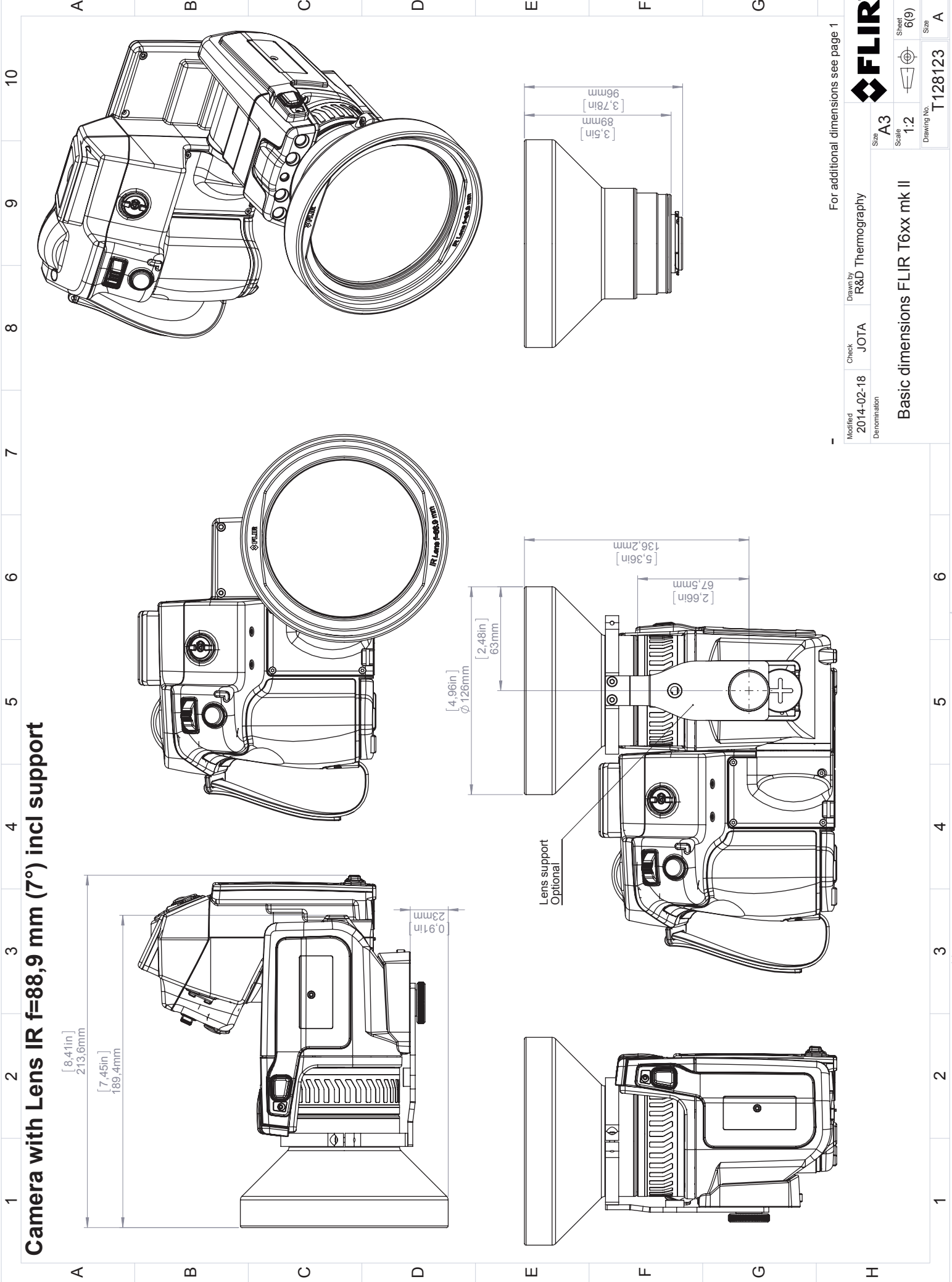

© 2012, FLIR Systems, Inc. All rights reserved worldwide. No part of this drawing may be reproduced, stored in a retrieval system, or transmitted in any form, or by any means, electronic, mechanical, photocopying, recording, or otherwise, without written permission from FLIR Systems, Inc. Specifications subject to change without further notice. Dimensional data is based on nominal values. Products may be subject to regional market considerations. License procedures may apply. Product may be subject to US Export Regulations. Please refer to exportquestions@flir.com with any questions. Diversion contrary to US law is prohibited.

Modified 2014-02-18	Check JOTA	Drawn by R&D Thermography	For additional dimensions see page 1
Denomination Basic dimensions FLIR T6xx mk II		Size A3	Sheet 6(9)
		Scale 1:2	Drawing No. T128123
			Size A

# Camera with Close-up lens 1,5X (25 µm)

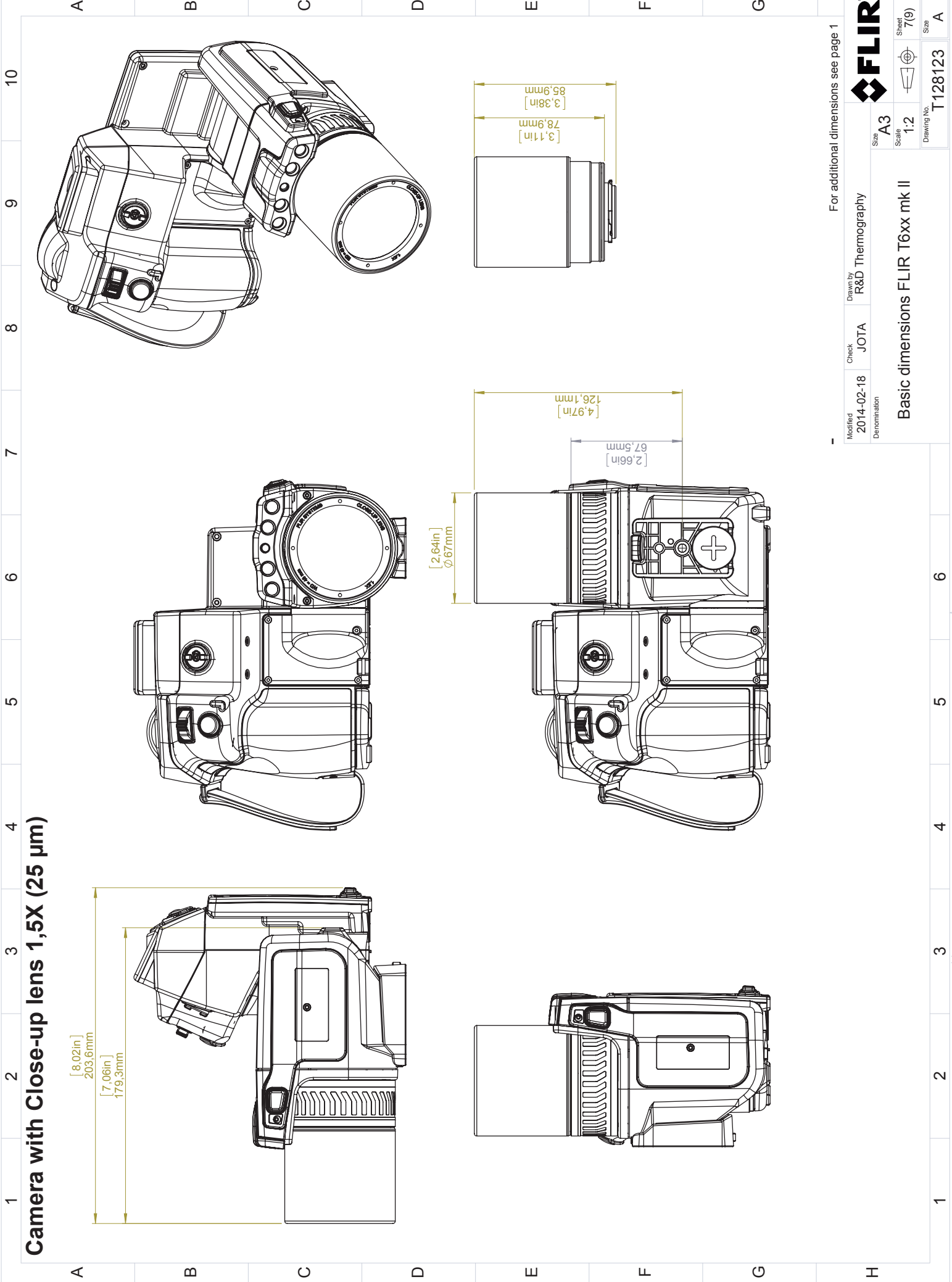

Product may be subject to US Export Regulations. Please refer to exportquestions@flir.com with any questions. Diversion contrary to US law is prohibited.  
 © 2012, FLIR Systems, Inc. All rights reserved worldwide. No part of this drawing may be reproduced, stored in a retrieval system, or transmitted in any form, or by any means, electronic, mechanical, photocopying, recording, or otherwise, without written permission from FLIR Systems, Inc. Specifications subject to change without further notice. Dimensional data is based on nominal values. Products may be subject to regional market considerations. License procedures may apply.

For additional dimensions see page 1

Modified	2014-02-18	Check	JOTA	Drawn by	R&D Thermography	Size	A3
Denomination						Scale	1:2
						Sheet	7(9)
						Drawing No.	T128123
						Size	A

Basic dimensions FLIR T6xx mk II

# Camera with Close-up lens 2,9X (50 μm)

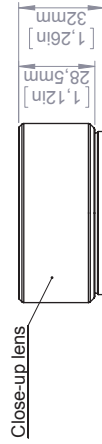
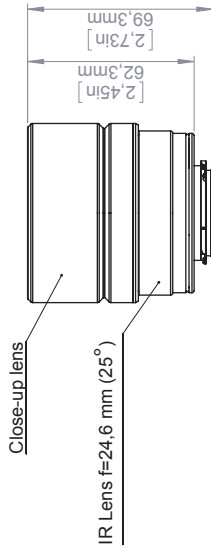
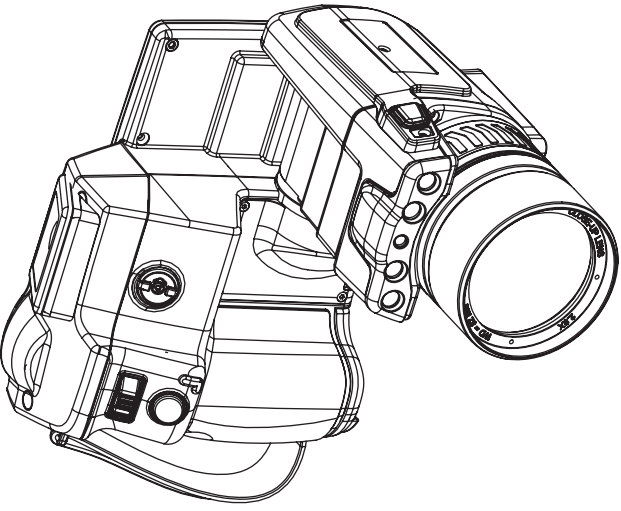
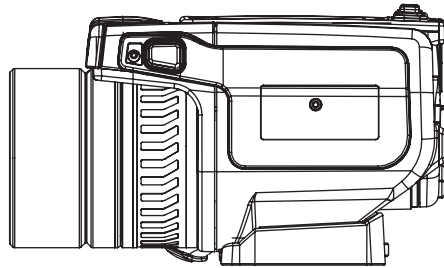
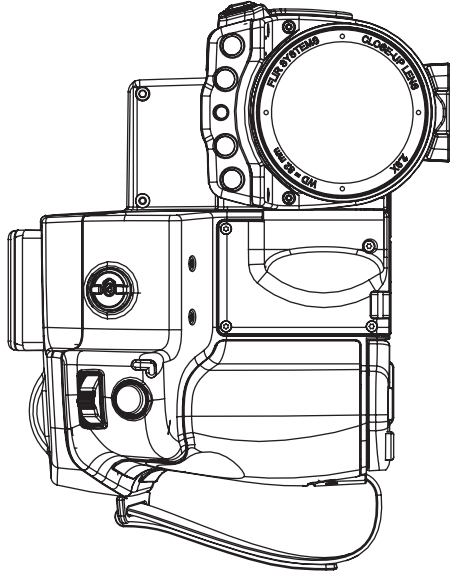
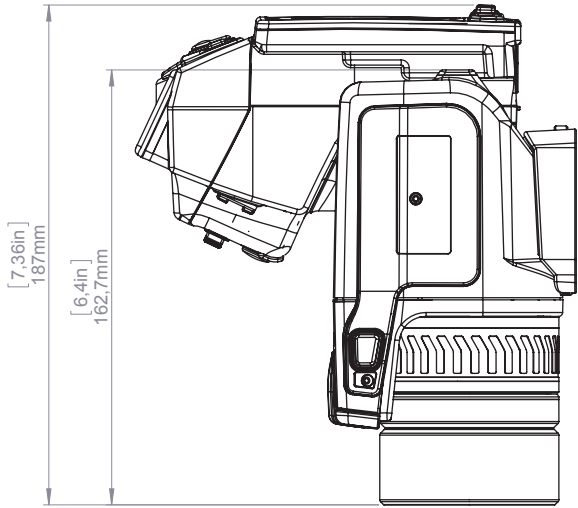

For additional dimensions see page 1

Modified 2014-02-18  
2014-02-18  
Denomination

Check JOTA

Drawn by R&D Thermography

Size A3

Scale 1:2

Sheet 8(9)

Size A

Basic dimensions FLIR T6xx mk II

Drawing No. T128123

# Camera with Close-up lens 5,8X (100 µm)

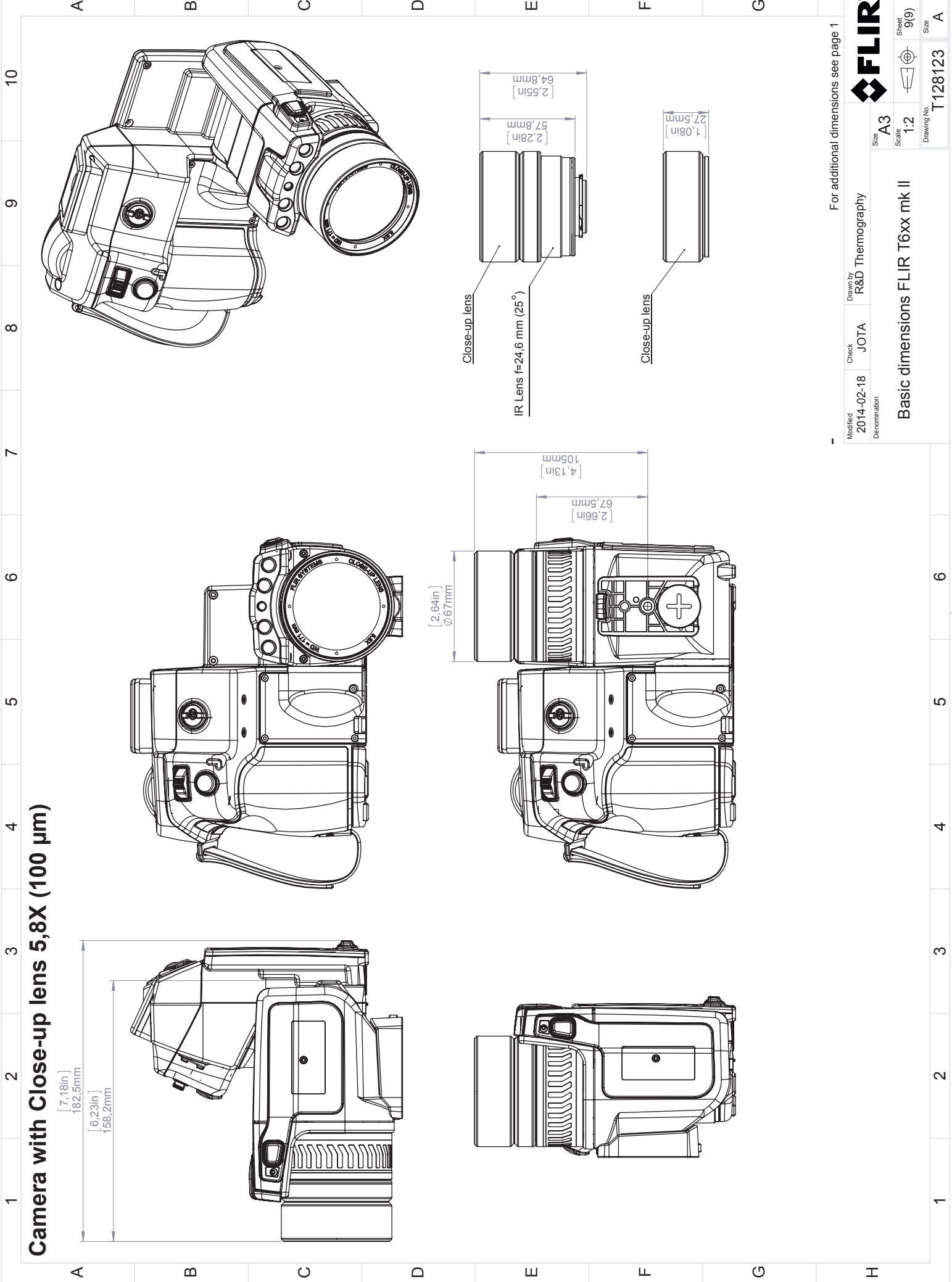
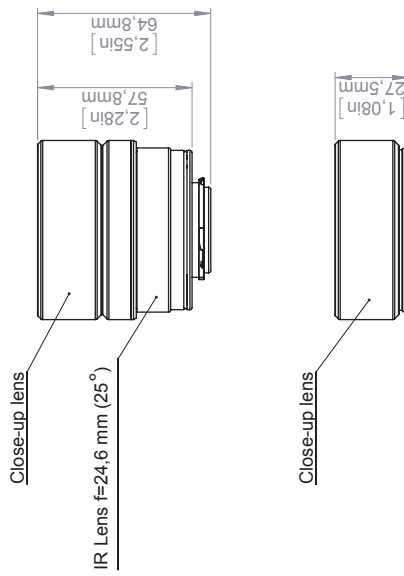
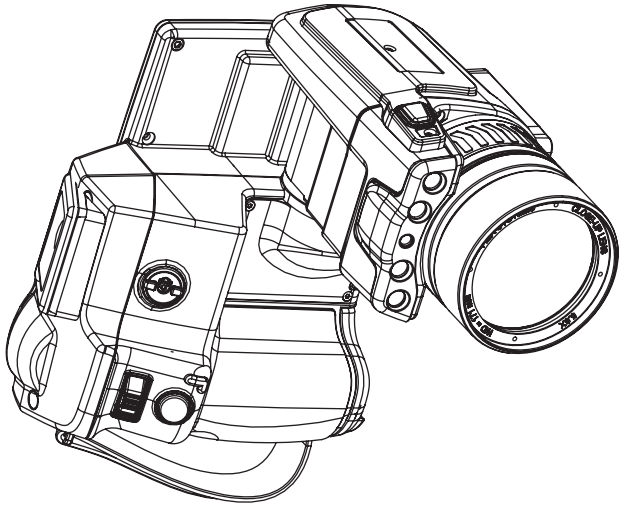
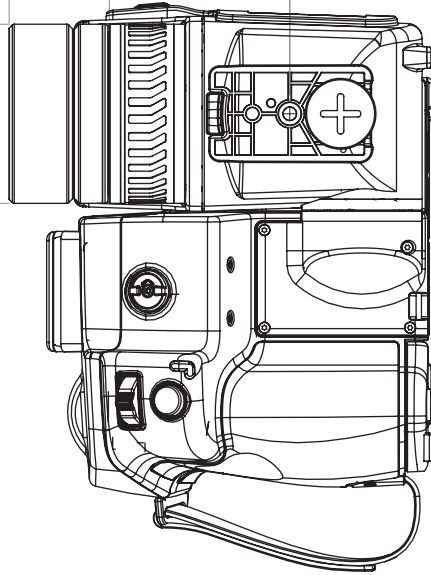
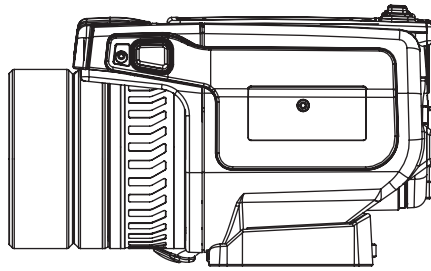
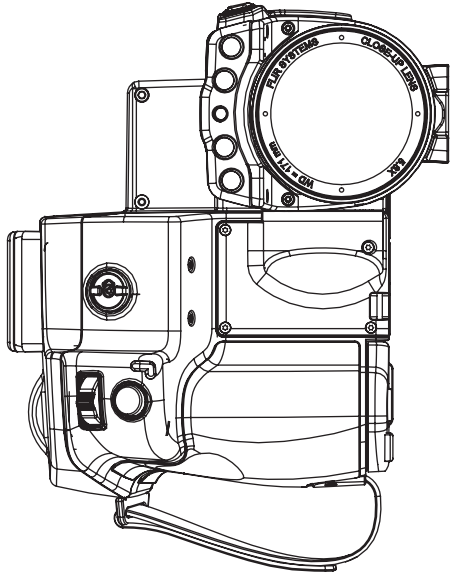
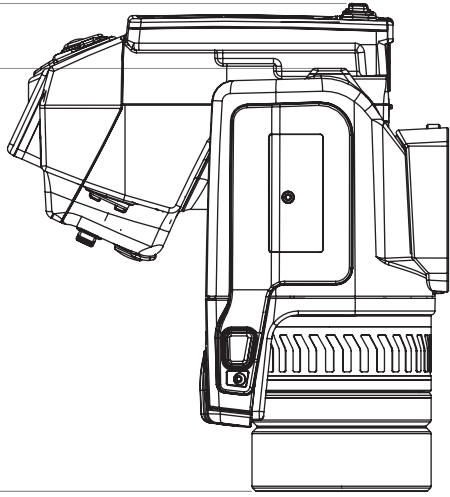

© 2012, FLIR Systems, Inc. All rights reserved worldwide. No part of this drawing may be reproduced, stored in a retrieval system, or transmitted in any form, or by any means, electronic, mechanical, photocopying, recording, or otherwise, without written permission from FLIR Systems, Inc. Specifications subject to change without further notice. Dimensional data is based on nominal values. Products may be subject to regional market considerations. License procedures may apply. Product may be subject to US Export Regulations. Please refer to exportquestions@flir.com with any questions. Diversion contrary to US law is prohibited.

For additional dimensions see page 1

Modified 2014-02-18	Check JOTA	Drawn by R&D Thermography	FLIR
Denomination Basic dimensions FLIR T6xx mk II			Size A3
Drawing No. T128123			Sheet 9(9)
Scale 1:2			Size A



[See next page]



August 02, 2017 Täby, Sweden

AQ320250

**CE Declaration of Conformity – EU Declaration of Conformity**

Product: FLIR T6XX -series

Name and address of the manufacturer:

FLIR Systems AB

PO Box 7376

SE-187 15 Täby, Sweden

This declaration of conformity is issued under the sole responsibility of the manufacturer.

The object of the declaration: FLIR T6XX -series (Product Model Name FLIR-T5590).

The object of the declaration described above is in conformity with the relevant Union harmonisation legislation:

**Directives:**

Directive	2014/30/EU	Electromagnetic Compability
Directive	2014/35/EU	Low Voltage Directive
Directive	2012/19/EU	Waste electrical and electric equipment
Directive	2014/53/EU	Radio Equipment Directive (RED)
Directive	1999/519/EC	Limitation of exposure to electromagnetic fields (SAR)
Directive	2011/65/EU	RoHS and 2015/830/EU (Phtalates)

**Standards:**

Emission:	EN 61000-6-3:2007	EMC – Generic standards
Immunity:	EN 61000-6-2:2005	Electromagnetic Compability Generic
	EN 301489-1:2008 v1.8.0	ERM – EMC for radio equipment
	EN 301489-17:2009 v2.1.1	ERM – EMC Wideband data
Laser:	EN 60825-1	Safety of laser products
Radio:	ETSI EN 300 328 v2.1.1	Harmonized EN covering essential requirements of the R&TTE Directive
	ETSI EN 301 893 v.2.1.1	5GHz WLAN
SAR:	EN 50360:2001/A1:2012	Human exposure (300 MHz – 3 GHz)
	EN 50566:2013/AC:2014	Handheld general public (30 MHz – 6 GHz)
Safety:	IEC 60950-1:2005+A1:2009+	Information technology equipment
	EN 60950-1:2006+A11:2009+A1:2010	
RoHS	EN 50581:2012	Technical documentation

**FLIR Systems AB**  
Quality Assurance

Lea Dabiri  
Quality Manager

## 27.1 Camera housing, cables, and other items

### 27.1.1 Liquids

Use one of these liquids:

- Warm water
- A weak detergent solution

### 27.1.2 Equipment

A soft cloth

### 27.1.3 Procedure

Follow this procedure:

1. Soak the cloth in the liquid.
2. Twist the cloth to remove excess liquid.
3. Clean the part with the cloth.

	<b>CAUTION</b>
Do not apply solvents or similar liquids to the camera, the cables, or other items. This can cause damage.	

## 27.2 Infrared lens

### 27.2.1 Liquids

Use one of these liquids:

- A commercial lens cleaning liquid with more than 30% isopropyl alcohol.
- 96% ethyl alcohol (C<sub>2</sub>H<sub>5</sub>OH).

### 27.2.2 Equipment

Cotton wool

	<b>CAUTION</b>
If you use a lens cleaning cloth it must be dry. Do not use a lens cleaning cloth with the liquids that are given in section 27.2.1 above. These liquids can cause material on the lens cleaning cloth to become loose. This material can have an unwanted effect on the surface of the lens.	

### 27.2.3 Procedure

Follow this procedure:

1. Soak the cotton wool in the liquid.
2. Twist the cotton wool to remove excess liquid.
3. Clean the lens one time only and discard the cotton wool.

	<b>WARNING</b>
Make sure that you read all applicable MSDS (Material Safety Data Sheets) and warning labels on containers before you use a liquid: the liquids can be dangerous.	

	<b>CAUTION</b>
<ul style="list-style-type: none"> <li>• Be careful when you clean the infrared lens. The lens has a delicate anti-reflective coating.</li> <li>• Do not clean the infrared lens too vigorously. This can damage the anti-reflective coating.</li> </ul>	

---

## 27.3 Infrared detector

### 27.3.1 General

Even small amounts of dust on the infrared detector can result in major blemishes in the image. To remove any dust from the detector, follow the procedure below.

#### Note

- This section only applies to cameras where removing the lens exposes the infrared detector.
- In some cases the dust cannot be removed by following this procedure: the infrared detector must be cleaned mechanically. This mechanical cleaning must be carried out by an authorized service partner.



#### CAUTION

In Step 2 below, do not use pressurized air from pneumatic air circuits in a workshop, etc., as this air usually contains oil mist to lubricate pneumatic tools.

### 27.3.2 Procedure

Follow this procedure:

1. Remove the lens from the camera.
2. Use pressurized air from a compressed air canister to blow off the dust.

## 28.1 Moisture & water damage

### 28.1.1 General

It is often possible to detect moisture and water damage in a house by using an infrared camera. This is partly because the damaged area has a different heat conduction property and partly because it has a different thermal capacity to store heat than the surrounding material.

Many factors can come into play as to how moisture or water damage will appear in an infrared image.

For example, heating and cooling of these parts takes place at different rates depending on the material and the time of day. For this reason, it is important that other methods are used as well to check for moisture or water damage.

### 28.1.2 Figure

The image below shows extensive water damage on an external wall where the water has penetrated the outer facing because of an incorrectly installed window ledge.

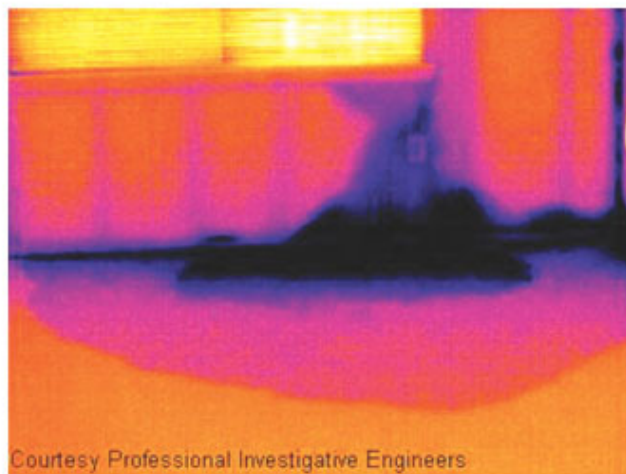

## 28.2 Faulty contact in socket

### 28.2.1 General

Depending on the type of connection a socket has, an improperly connected wire can result in local temperature increase. This temperature increase is caused by the reduced contact area between the connection point of the incoming wire and the socket, and can result in an electrical fire.

A socket's construction may differ dramatically from one manufacturer to another. For this reason, different faults in a socket can lead to the same typical appearance in an infrared image.

Local temperature increase can also result from improper contact between wire and socket, or from difference in load.

### 28.2.2 Figure

The image below shows a connection of a cable to a socket where improper contact in the connection has resulted in local temperature increase.