

User Manual

Version 1.0 October 2012

Terminal Hardware System

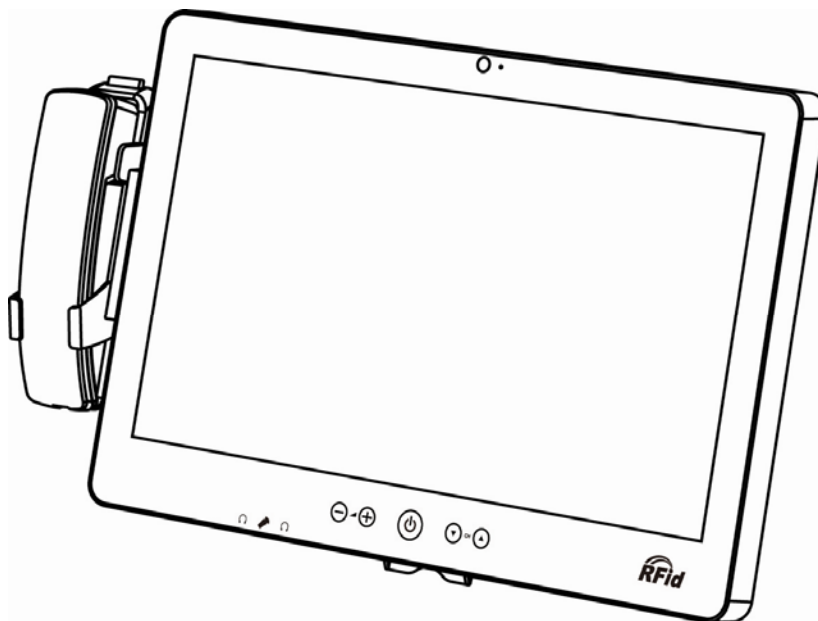

Copyright 2012
All Rights Reserved
Manual Version 1.0
Part Number:

The information contained in this document is subject to change without notice.

We make no warranty of any kind with regard to this material, including, but not limited to, the implied warranties of merchantability and fitness for a particular purpose. We shall not be liable for errors contained herein or for incidental or consequential damages in connection with the furnishing, performance, or use of this material.

This document contains proprietary information that is protected by copyright. All rights are reserved. No part of this document may be photocopied, reproduced or translated to another language without the prior written consent of the manufacturer.

TRADEMARK

Intel®, Pentium® and MMX are registered trademarks of Intel® Corporation. Microsoft® and Windows® are registered trademarks of Microsoft Corporation.

Other trademarks mentioned herein are the property of their respective owners.

Safety

IMPORTANT SAFETY INSTRUCTIONS

1. To disconnect the machine from the electrical Power Supply, turn off the power switch and remove the power cord plug from the wall socket. The wall socket must be easily accessible and in close proximity to the machine.
2. Read these instructions carefully. Save these instructions for future reference.
3. Follow all warnings and instructions marked on the product.
4. Do not use this product near water.
5. Do not place this product on an unstable cart, stand, or table. The product may fall, causing serious damage to the product.
6. Slots and openings in the cabinet and the back or bottom are provided for ventilation; to ensure reliable operation of the product and to protect it from overheating. These openings must not be blocked or covered. The openings should never be blocked by placing the product on a bed, sofa, rug, or other similar surface. This product should never be placed near or over a radiator or heat register, or in a built-in installation unless proper ventilation is provided.
7. This product should be operated from the type of power indicated on the marking label. If you are not sure of the type of power available, consult your dealer or local power company.
8. Do not allow anything to rest on the power cord. Do not locate this product where persons will walk on the cord.
9. Never push objects of any kind into this product through cabinet slots as they may touch dangerous voltage points or short out parts that could result in a fire or electric shock. Never spill liquid of any kind on the product.

CE MARK



This device complies with the requirements of the EEC directive 2004/108/EC with regard to “Electromagnetic compatibility” and 2006/95/EC “Low Voltage Directive”

FCC

This device complies with part 15 of the FCC rules. Operation is subject to the following two conditions:

- (1) This device may not cause harmful interference.
- (2) This device must accept any interference received, including interference that may cause undesired operation

CAUTION ON LITHIUM BATTERIES

There is a danger of explosion if the battery is replaced incorrectly. Replace only with the same or equivalent type recommended by the manufacturer. Discard used batteries according to the manufacturer's instructions.



Battery Caution

Risk of explosion if battery is replaced by an incorrectly type. Dispose of used battery according to the local disposal instructions.



Safety Caution

Note: To comply with IEC60950-1 Clause 2.5 (limited power sources, L.P.S) related legislation, peripherals shall be 4.7.3.2 "Materials for fire enclosure" compliant.

4.7.3.2 Materials for fire enclosures

For MOVABLE EQUIPMENT having a total mass not exceeding 18kg.the material of a FIRE ENCLOSURE, in the thinnest significant wall thickness used, shall be of V-1 CLASS MATERIAL or shall pass the test of Clause A.2.

For MOVABLE EQUIPMENT having a total mass exceeding 18kg and for all STATIONARY EQUIPMENT, the material of a FIRE ENCLOSURE, in the thinnest significant wall thickness used, shall be of 5VB CLASS MATERIAL or shall pass the test of Clause A.1

LEGISLATION AND WEEE SYMBOL

2012/19/EU Waste Electrical and Electronic Equipment Directive on the treatment, collection, recycling and disposal of electric and electronic devices and their components.



The crossed dustbin symbol on the device means that it should not be disposed of with other household wastes at the end of its working life. Instead, the device should be taken to the waste collection centers for activation of the treatment, collection, recycling and disposal procedure.

To prevent possible harm to the environment or human health from uncontrolled waste disposal, please separate this from other types of wastes and recycle it responsibly to promote the sustainable reuse of material resources.

Household users should contact either the retailer where they purchased this product, or their local government office, for details of where and how they can take this item for environmentally safe recycling.

Business users should contact their supplier and check the terms and conditions of the purchase contract.

This product should not be mixed with other commercial wastes for disposal.

Revision History

Revision	Date	Description
V1.0	October, 2012	● Release

Table Contents

1 Package Checklist	1
1-1 Standard Items	1
2 System View	2
2-1 Front View.....	2
2-2 Side View.....	3
2-3 Rear View	3
2-4 Bottom View	4
2-5 Dimension.....	4
3 System Assembly	5
3-1 SSD Card Replacement.....	5
4 Peripheral Installation	6
4-1 Phone module Installation.....	6
4-2 Arm Installation	7
5 Specification	8
6 Jumper Settings	10
6-1 C43 motherboard layout.....	10
6-2 Connectors & Functions.....	11
6-3 Jumper Setting.....	13
7 Drivers Installation	15

1 Package Checklist

1-1 Standard Items

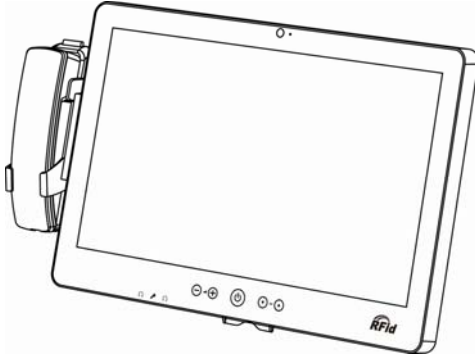

a. System

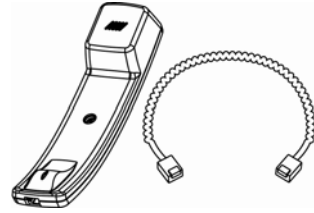

b. Phone module

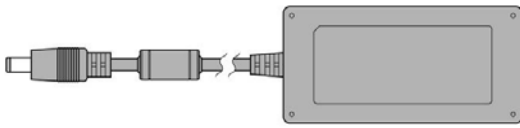

c. Power adapter

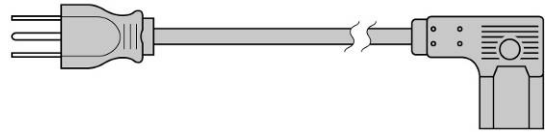

d. Power cable

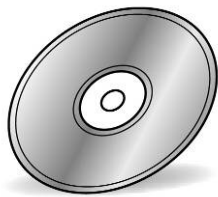

e. Driver CD

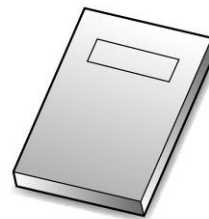

f. Manual

2 System View

2-1 Front View

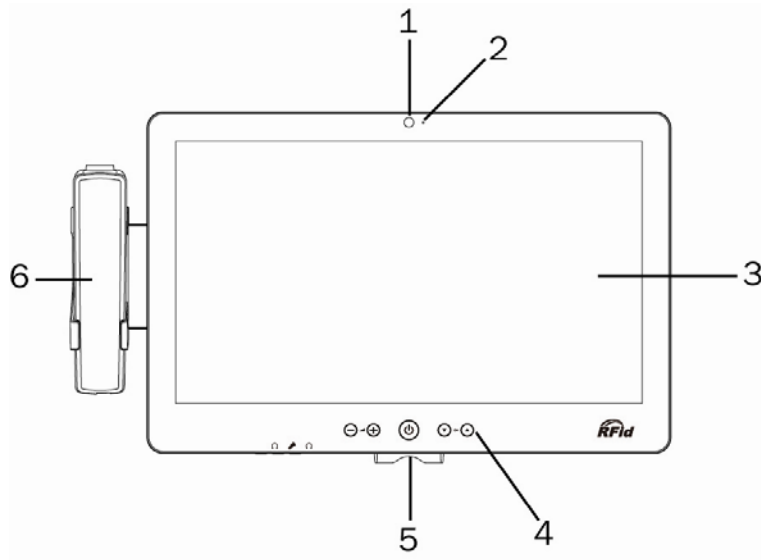

Number	Description
1	Build-in camera
2	Camera LED
3	Touch screen
4	Touch keys (from left to right: volume down, volume up, power button, channel down, channel up)
5	Smart IC card reader
6	VOIP phone (optional)

2-2 Side View

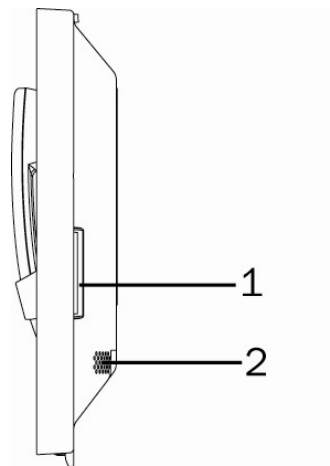

Number	Description
1	Combo smart IC card reader with separate RFID antenna (optional)
2	Speaker

2-3 Rear View

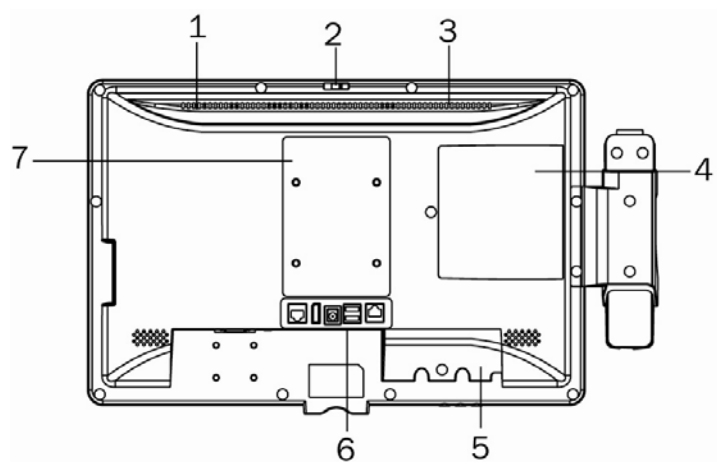

Number	Description
1	Light Sensor
2	Webcam switch
3	Ventilation
4	SSD card door
5	Cable cover
6	Vertical I/O port (from left to right: Nurse call, Display port, DC jack, USBx2, LAN)
7	VESA hole for wall-mount kit installation

2-4 Bottom View

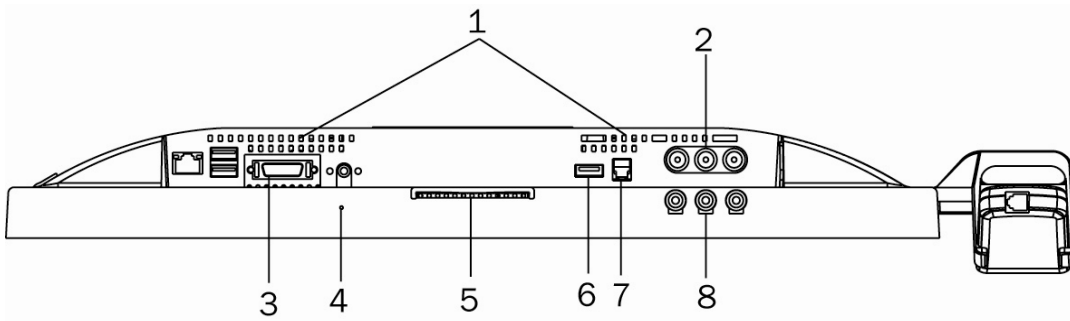

Number	Description
1	Ventilation
2	From left to right: Video in, Audio left, Audio right (optional)
3	Bottom I/O port (from left to right: LAN, USBx2, Remote, Power button)
4	Microphone
5	Smart IC card reader
6	USBx1
7	Phone jack (RJ11)
8	From left to right: Audio line-out, Mic-in, Audio line-out

2-5 Dimension

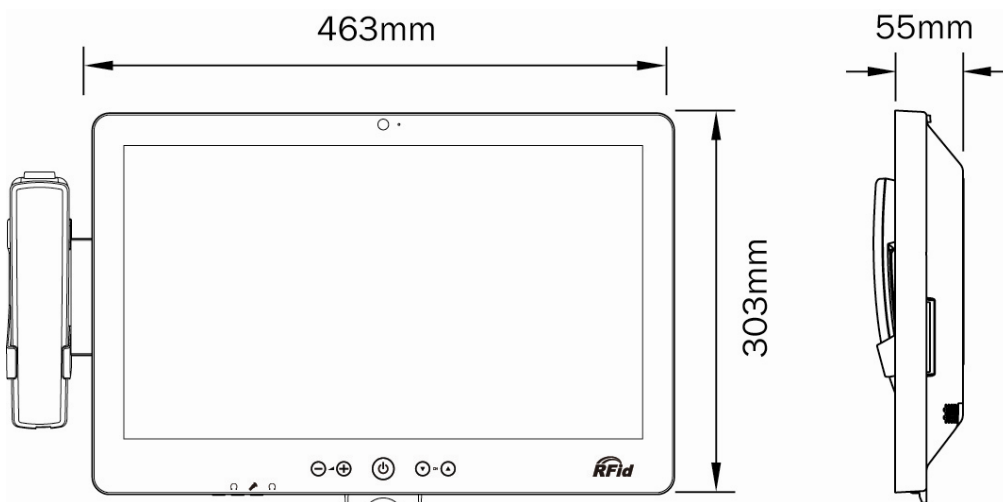

3 System Assembly

3-1 SSD Card Replacement

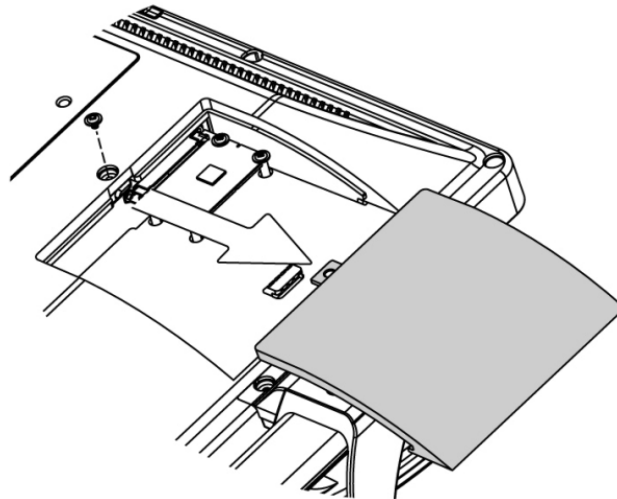

1. Find the SSD card door at the rear right side of the system and remove the screws(x1)

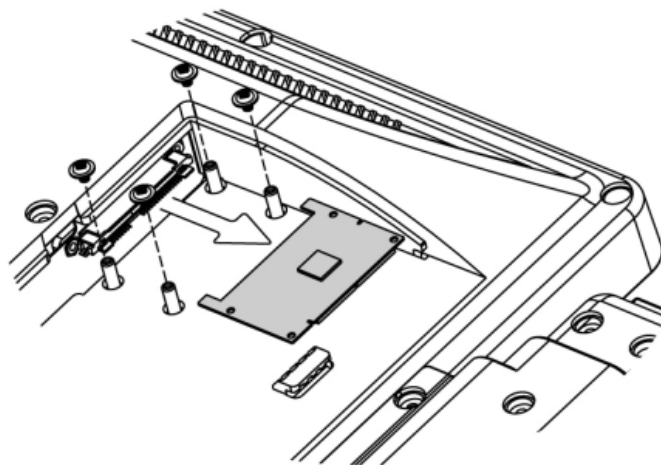

2. To replace the SSD card, remove the screws (x4) and push the SSD card outwards as shown in the picture.

4 Peripheral Installation

4-1 Phone module Installation

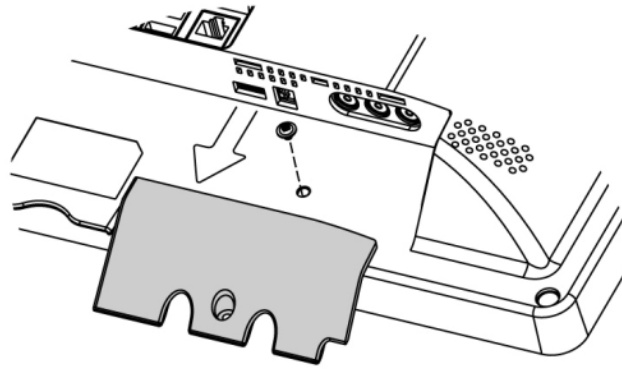

1. Loosen the screw(x1) to open the cable cover.

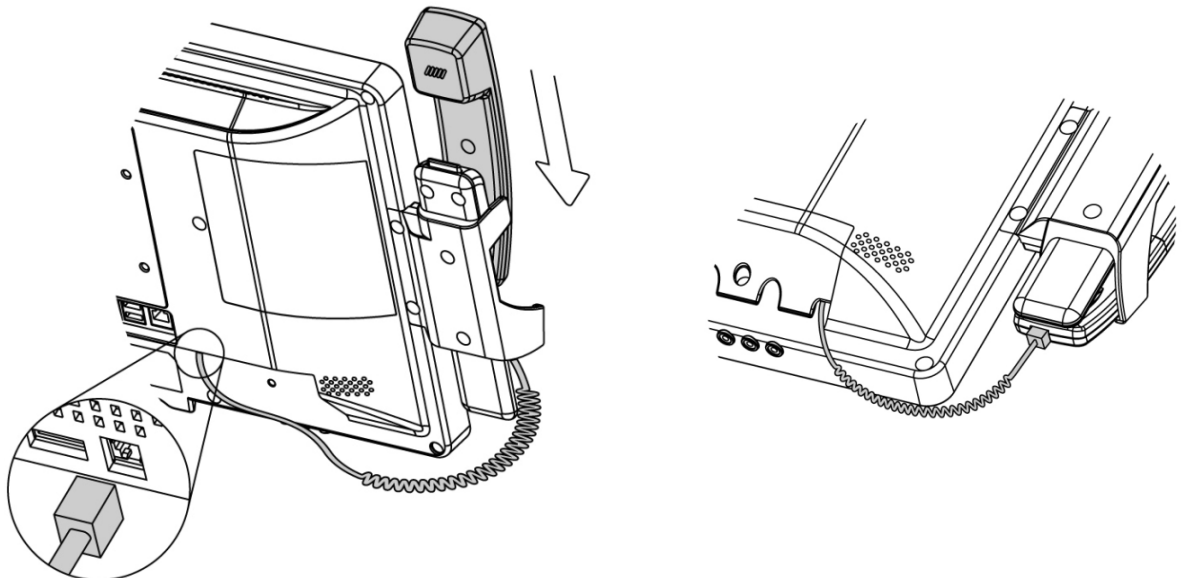

2. Slide the phone module into the phone holder and connect the other end of the phone cable to the connector on the system.

4-2 Wall Mount Installation

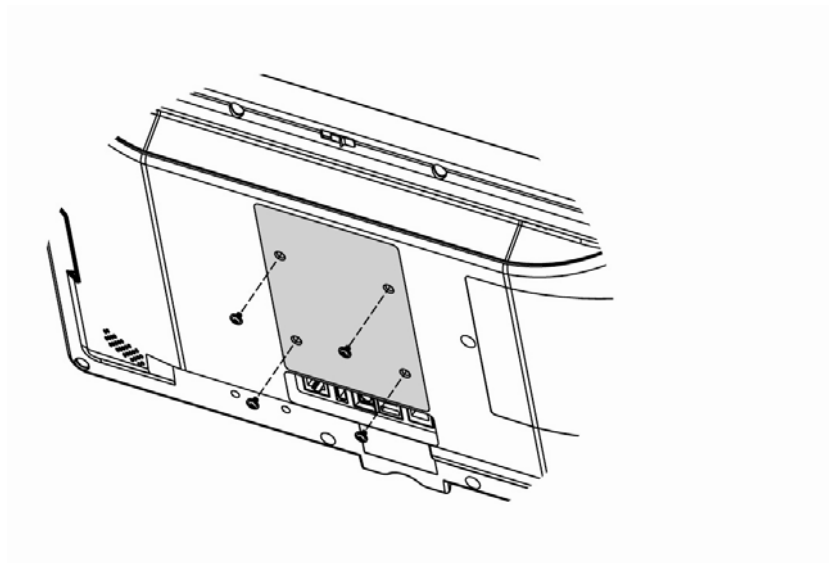

1. Connect the cables to the system.
2. Fasten the screws.(monitor screwx4)

Note: For use only with UL listed wall mount bracket with minimum support weight/load: 5.2kg

5 Specification

Model	PA79
Motherboard	C43
Processor	Pineview D525
Core Logic	CPU with Graphic built-in + ICH 8M
System Memory	2 x DDR3 SO-DIMM slot up to 4GB FSB800Mhz
Graphic Memory	Intel GMA 3150 share system memory up to 256MB
LAN Controller / PHY	Intel WG82583V / Intel WG82567V
Audio Controller	Realtek ALC 662-GR HD codec
I/O Controller	Winbond W83627UHG
Touch	TF P-cap 18.5"
Camera LED	Green-color (GPIO)
Microphone	1
Power LED	Tri-color (GPIO)
Watch Dog Timer	Hardware WDT
Display Size	18.5"
Resolution	1366x768
Brightness	250 nits
DC-In	19V
Storage	
HDD	1x SSD
Expansion	
Mini PCI e	2 x PCI-e full size slot
Side I/O (Back-Left)	
Smart IC Card Reader (optional)	1
Rear I/O (Left)	
LAN (2nd LAN)	1xRJ45 (with 10/100/1000,LED indicator)
USB	2 (USB 2.0)
Remote	1x SCSI 26pin
Reset Button	1, button can be pressed by probe
Power Button	1
Rear I/O (Right)	
Composite Video	Video in, Audio Left, Audio Right
Line-out	2 (Auto-detect,GPIO), in external IO

Model	PA79
Motherboard	C43
Mic-In	1 (Auto-detect,GPIO), in external IO
Vertical I / O	
LAN	1 x RJ45 (with 10/100/1000)
Power	DC Jack
Display Port	1
USB	2 (USB 2.0)
Nurse Call	1 x RJ48
Touch Keys	
Power Button	1xPower button (GPIO)
Channel Adjustment	1xChannel up, 1xChannel down (GPIO)
Volume	1xVolume up, 1xVolume down (GPIO)
Environment	
EMC & Safety	FCC Class B, CE, LVD / UL60950 / EN60601
Environment	
Operating Temperature	0°C ~ 35°C (32°F ~ +95°F)
Storage Temperature	-20°C ~ 60°C (-4°F ~ 140°F)
Humidity	20% - 85% RH non condensing
Weight	
Weight	5Kgs
Operating System	
OS Support	Windows Embedded POSReady7, Windows 7, Linux
Communication & Peripherals	
Speaker	2x3W
Build In Microphone	In the bottom side
Webcam	5M web cam (USB interface) with webcam door (w/ fly LED cable to MB & control by GPIO)
VOIP Phone (Front left)	Handset module (optional)
Smart IC Card Reader	Comply with ISO 7816-1,2,3,T=1 and T=0 protocol
Combo Smart IC Card Reader (optional) with separate RFID antenna in the front bezel	Comply with ISO 7816-1,2,3,T=1 and T=0 Support MIFARE, MIFARE+ ,Desfire, PC/SC 2.0, HID
Light Sensor	Yes (GPIO)
TV Tuner & DVD Maker Card	Mechanical reserved

6 Jumper Settings

6-1 C43 motherboard layout

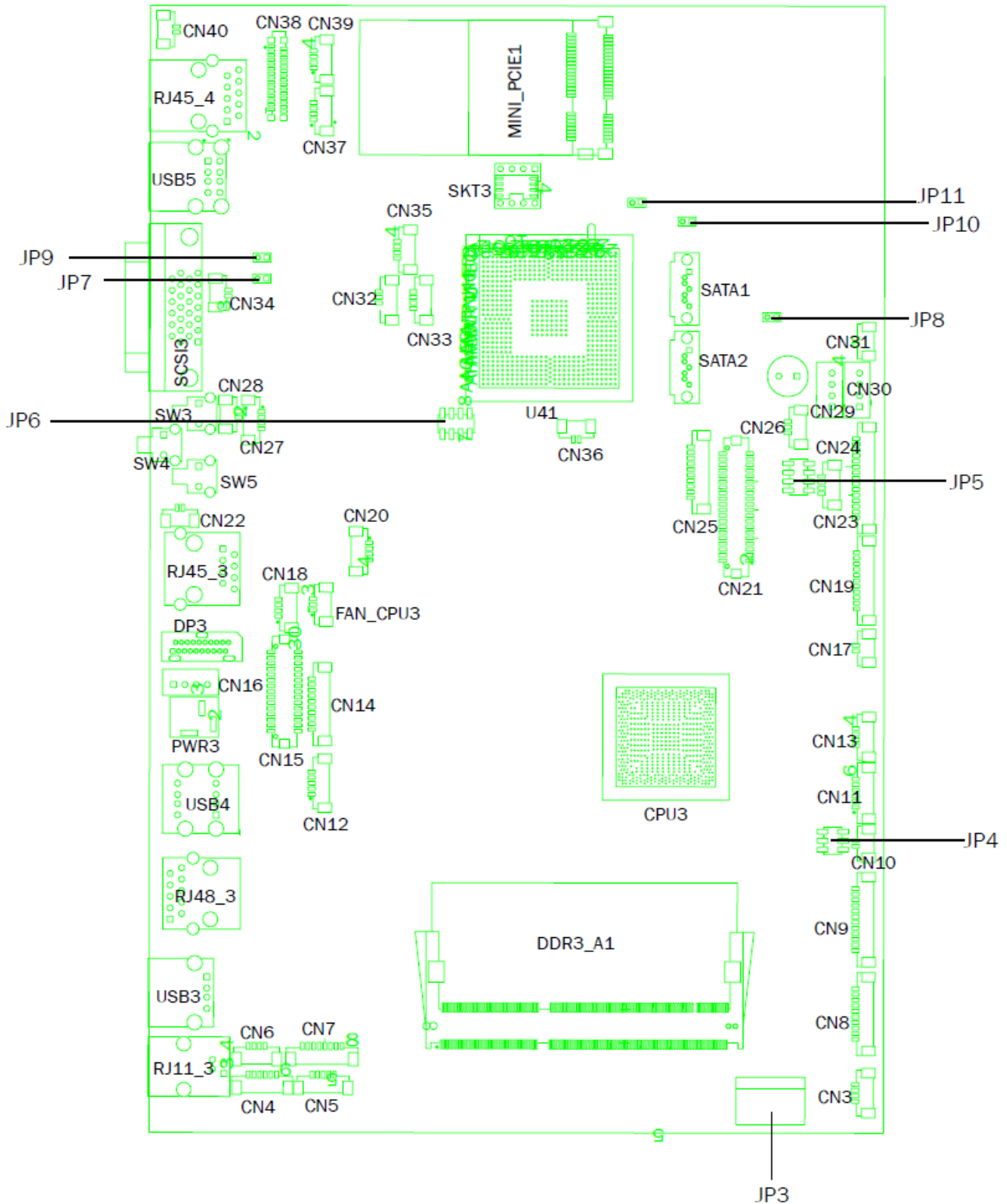

6-2 Connectors & Functions

Connector	Function
CN3	USB Port For Web Cam
CN4	Speaker & MIC
CN5	Cradle
CN6	Speaker
CN7	Audio Jack (Line out & MIC)
CN9	Inverter
CN10	Build-In MIC
CN12	Nurse Call Button
CN14	Membrane
CN15	30P All-In-One (Membrane, 2D scanner, RFID, Smart card, Audio Jack)
CN17	Nurse Call LED Power
CN18	Audio Jack (Line Out)
CN19/JP5	System Indicator
CN20	IrDA
CN21	LVDS
CN22	Power LED
CN23	PS/2 Keyboard
CN24	MSR
CN25	COM1
CN26	System FAN
CN27	MIC for AEC
CN28	Power Button
CN29/30	SATA Power
CN31	HDD LED
CN32/35	Internal USB
CN33	USB Port For DVD Dong
CN34	LAN2 LED
CN36	Battery
CN37	USB Port For RFID
CN38	2D Scanner
CN39	USB Port For Smart Card
CN40	LAN1 LED
DP3	DVI
PWR3	+19V DC Jack
RJ11_3	Handset
RJ45_3	LAN2
RJ45_4	LAN1

Connector	Function
RJ48_3	Nurse Call
SATA1/2	SATA
SCSI_3	Remote Control
USB3	USB3
USB4	USB1, USB2 of HUB
USB5	USB1, USB2
JP3	Touch
JP4	Inverter Selection
JP6	LCD ID Setting
JP7	MCU Power Button
JP8	Power Mode Setting
JP9	MCU Mode Setting
JP10	System Reset
JP11	CMOS Operation Mode

6-3 Jumper Setting

Inverter Selection

Function	JP4 (1-2) (3-4) (5-6)
CCFL	<pre> 1 3 5 □ □ ■ □ □ ■ 2 4 6 </pre>
▲ LED	<pre> 1 3 5 ■ ■ □ ■ ■ □ 2 4 6 </pre>

System Indicator

Function	JP5 (1-2) (3-4) (5-6) (7-8)
▲ Disable	<pre> 1 3 5 7 ■ ■ □ □ ■ ■ □ □ 2 4 6 8 </pre>
Enable	<pre> 1 3 5 7 □ □ ■ ■ □ □ ■ ■ 2 4 6 8 </pre>

MCU Power Button

Function	JP7 (1-2)
Disable	<pre> 1 □ □ 2 </pre>
▲ Enable	<pre> 1 ■ ■ 2 </pre>

Power Mode Setting

Function	JP8 (1-2)
▲ ATX Power	<pre> 1 □ □ 2 </pre>
AT Power	<pre> 1 ■ ■ 2 </pre>

MCU Mode Setting

Function	JP9 (1-2)
▲ Normal	<div style="display: flex; flex-direction: column; align-items: center;"> 1 <div style="border: 1px solid black; width: 10px; height: 10px; margin: 2px;"></div> <div style="border: 1px solid black; width: 10px; height: 10px; margin: 2px;"></div> 2 </div>
ISP Debug	<div style="display: flex; flex-direction: column; align-items: center;"> 1 <div style="background-color: black; width: 10px; height: 10px; margin: 2px;"></div> <div style="background-color: black; width: 10px; height: 10px; margin: 2px;"></div> 2 </div>

System Reset

Function	JP10 (1-2)
▲ System Normal	<div style="display: flex; flex-direction: column; align-items: center;"> 1 <div style="border: 1px solid black; width: 10px; height: 10px; margin: 2px;"></div> <div style="border: 1px solid black; width: 10px; height: 10px; margin: 2px;"></div> 2 </div>
System Reset	<div style="display: flex; flex-direction: column; align-items: center;"> 1 <div style="background-color: black; width: 10px; height: 10px; margin: 2px;"></div> <div style="background-color: black; width: 10px; height: 10px; margin: 2px;"></div> 2 </div>

CMOS Operation Mode

Function	JP11 (1-2)
▲ CMOS Normal	<div style="display: flex; flex-direction: column; align-items: center;"> 1 <div style="border: 1px solid black; width: 10px; height: 10px; margin: 2px;"></div> <div style="border: 1px solid black; width: 10px; height: 10px; margin: 2px;"></div> 2 </div>
CMOS Reset	<div style="display: flex; flex-direction: column; align-items: center;"> 1 <div style="background-color: black; width: 10px; height: 10px; margin: 2px;"></div> <div style="background-color: black; width: 10px; height: 10px; margin: 2px;"></div> 2 </div>

▲ = Manufacturer Default Setting

Note:  OPEN

 SHORT

7 Drivers Installation

The shipping package includes a Driver CD. You can find every individual driver and utility that enables you to install the drivers in the Driver CD.

Please insert the Driver CD into the drive and double click on the “index.htm” to pick up the models. You can refer to the drivers installation guide for each driver in the “Driver/Manual List”.