

# USER MANUAL

Version 1.0 August 2015

## POS260 Series

Model: P263/P265

Mobile PC

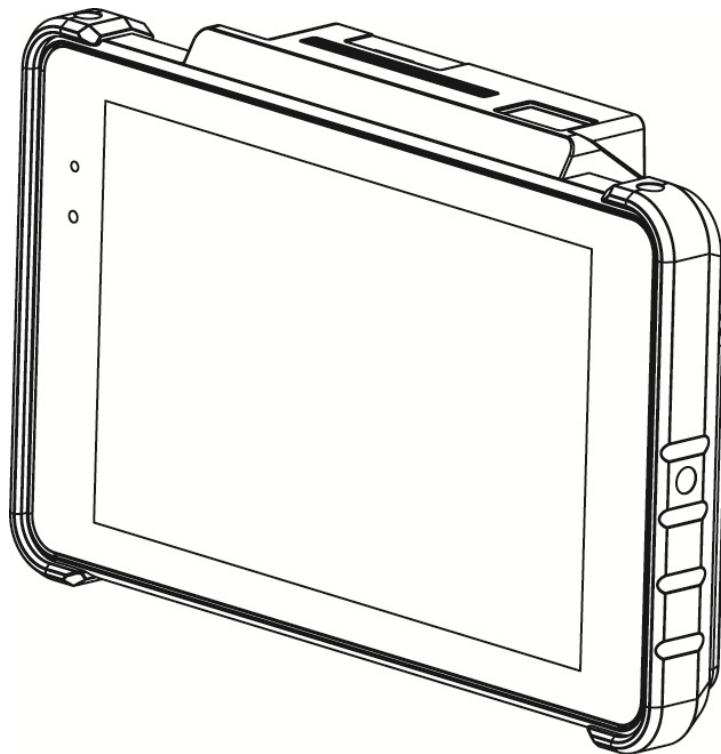

# Copyright

Copyright 2015  
All Rights Reserved  
Manual Version 1.0

The information contained in this document is subject to change without notice. We make no warranty of any kind with regard to this material, including, but not limited to, the implied warranties of merchantability and fitness for a particular purpose. We shall not be liable for errors contained herein or for incidental or consequential damages in connection with the furnishing, performance, or use of this material.

This document contains proprietary information that is protected by copyright. All rights are reserved. No part of this document may be photocopied, reproduced or translated to another language without the prior written consent of the manufacturer.

## TRADEMARK

The material in this manual is subject to change without notice. Bluetooth is a registered trademark of Bluetooth SIG. Microsoft®, Windows® and ActiveSync® are either registered trademarks or trademarks of Microsoft Corporation. All other product or service names are the property of their respective owners.

# Safety

## Regulatory Information

Caution: Only use approved and UL Listed accessories, battery packs and battery chargers. Do NOT attempt to charge damp/wet mobile computers or batteries. All components must be dry before connecting to an external power source.

## Power Supply

Use only the approved power supply 50-14000-148 output rated 5 Vdc and minimum 2 A. The power supply is certified to EN60950-1 with SELV outputs. Use of alternative power supply will invalidate any approval given to this device and may be dangerous.

## Warning for Use of Wireless Devices

Please observe all warning notices with regard to the usage of wireless devices.

## Potentially Hazardous Atmospheres

You are reminded of the need to observe restrictions on the use of radio devices in fuel depots, chemical plants etc. and areas where the air contains chemicals or particles (such as grain, dust, or metal powders) and any other area where you would normally be advised to turn off your vehicle engine.

## Safety in Aircraft

Switch off your wireless device whenever you are instructed to do so by airport or airline staff.

## Pacemakers

Pacemaker manufacturers recommended that a minimum of 15cm (6 inches) be maintained between a handheld wireless device and a pacemaker to avoid potential interference with the pacemaker. These recommendations are consistent with independent research and recommendations by Wireless Technology Research.

## Persons with Pacemakers

Persons with Pacemakers should ALWAYS keep the device more than 15cm (6 inches) from their pacemaker when turned ON and hence they should not carry the device in a breast pocket .

Should use the ear furthest from the pacemaker to minimize the potential for interference. If you have any reason to suspect that interference is taking place, turn OFF your device.

## Hearing Aids

The wireless device may interfere with some hearing aids. In the event of interference you may want to consult your hearing aid supplier to discuss solutions.

### Other Medical Devices

Please consult your physician or the manufacturer of the medical device, to determine if the operation of your wireless product may interfere with the medical device.

## FCC/EU RF Exposure Guidelines

### FCC Statement

This equipment has been tested and found to comply with the limits for a Class B digital device, pursuant to part 15 of the FCC Rules. These limits are designed to provide reasonable protection against harmful interference in a residential installation. This equipment generates, uses and can radiate radio frequency energy and, if not installed and used in accordance with the instructions, may cause harmful interference to radio communications. However, there is no guarantee that interference will not occur in a particular installation. If this equipment does cause harmful interference to radio or television reception, which can be determined by turning the equipment off and on, the user is encouraged to try to correct the interference by one or more of the following measures:

- Reorient or relocate the receiving antenna.
- Increase the separation between the equipment and receiver.
- Connect the equipment into an outlet on a circuit different from that to which the receiver is connected.
- Consult the dealer or an experienced radio/TV technician for help.

This device complies with FCC SAR exposure limits set forth for an uncontrolled environment.

This device complies with Part 15 of the FCC Rules. Operation is subject to the following two conditions: (1) this device may not cause harmful interference, and (2) this device must accept any interference received, including interference that may cause undesired operation.

### Caution!

Any changes or modifications not expressly approved by the party responsible for compliance could void the user's authority to operate the equipment.

 CE Marking and European Economic Area

The use of 2.4GHz WLAN's, for use through the EEA, have the following restrictions:

- Maximum radiated transmit power of 100 mW EIRP in the frequency range 2.400 -2.4835 GHz
- France, outside usage is restricted to 2.4 - 2.454 GHz.
- Italy requires a user license for outside usage.

Bluetooth® Wireless Technology for use through the EEA has the following restrictions:

- Maximum radiated transmit power of 100mW EIRP in the frequency range 2.400 -2.4835 GHz
- France, outside usage is restricted to 10mW EIRP
- Italy requires a user license for outside usage.

CE RF exposure

For body-worn operation, this device has been tested and meets the ICNIRP guidelines and the European Standard EN62209-2, for use with dedicated accessories.

SAR is measured with this device at a separation of 0cm to the body, while transmitting at the highest certified output power level in all frequency bands of this device.

## Battery Information

Our rechargeable battery packs are designed and constructed to the highest standards within the industry.

However, there are limitations to how long a battery can operate or be stored before needing replacement.

Many factors affect the actual life cycle of a battery pack, such as heat, cold, harsh environmental conditions and severe drops.

When batteries are stored over six (6) months, some irreversible deterioration in overall battery quality may occur. Store batteries discharged in a dry, cool place, removed from the equipment to prevent loss of capacity, rusting of metallic parts and electrolyte leakage.

When storing batteries for one year or longer, they should be charged and discharged at least once a year. If an electrolyte leakage is observed, avoid any contact with affected area and properly dispose of the battery. Batteries must be charged within the 32° to 95° F (0° to +35° C) ambient temperature range.

Replace the battery when a significant loss of run time is detected.



## Battery Caution

Risk of explosion if battery is replaced by an incorrectly type.

Dispose of used battery according to the local disposal instructions.



## Waste Electrical and Electronic Equipment (WEEE)

English: For EU Customers: All products at the end of their life must be returned to the reseller for recycling.

## Notational Conventions

The following conventions are used in this document:

- Italics are used to highlight specific items in the general text, and to identify chapters and sections in this and related documents.
- bullets (•) indicate:
  - action items
  - lists of alternatives
  - lists of required steps that are not necessarily sequential
  - Sequential lists (e.g., those that describe step-by-step procedures) appear as numbered lists.

**NOTE** This symbol indicates something of special interest or importance to the reader.

Failure to read the note will not result in physical harm to the reader, equipment or data.

**CAUTION** This symbol indicates that if this information is ignored, the possibility of data or material damage may occur.

**WARNING!** This symbol indicates that if this information is ignored the possibility that serious personal injury may occur.

# Revision History

Version	Date	Description
1.0	August 2015	Initial release





# Table of Contents

<b>1</b>	<b>Item Checklist .....</b>	<b>1</b>
1-1	Standard Items.....	1
1-2	Optional Items.....	2
<b>2</b>	<b>System View .....</b>	<b>3</b>
2-1	Front View.....	3
2-2	Rear View.....	4
2-3	Specification.....	5
<b>3</b>	<b>Getting Started.....</b>	<b>7</b>
3-1	Power On/Off the System.....	7
3-2	Installing the Hand Strap.....	7
3-3	Replacing the Battery.....	8
3-4	Using the Charging Cradle.....	9
3-5	Connect to Other Device.....	9
3-6	Replacing a Micro SD Card.....	10
3-7	Installing the 3G Card.....	11
<b>4</b>	<b>Application Programming Interface .....</b>	<b>12</b>
4-1	OpenFunKeyLib.....	13
4-2	SetFunKey1.....	14
4-3	SetFunKey2.....	15
4-4	Appendix A: KeyMap.ini.....	16

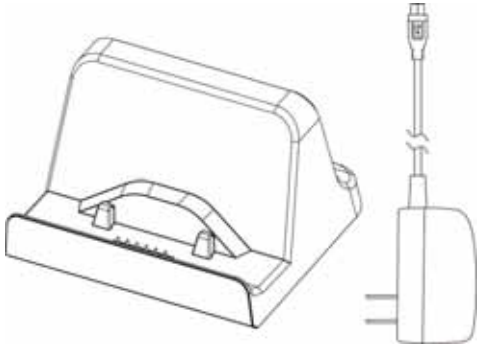

# 1 Item Checklist

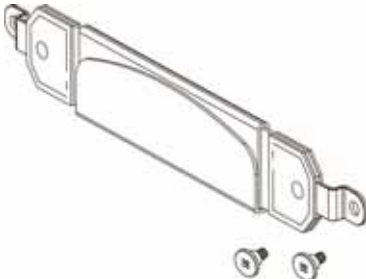
## 1-1 Standard Items

	
a. System	b. Charging cradle
	
c. Battery	d. Hand strap (with two screws)
	
e. Quick start guide	

## 1-2 Optional Items

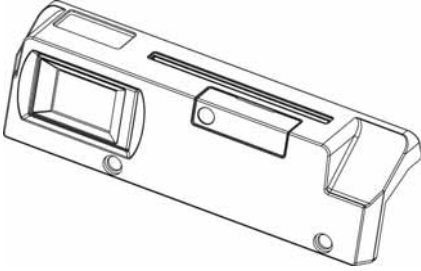
 A line drawing of an OTG (On-The-Go) cable. It features a standard USB-A connector on the left end and a USB-C connector on the right end. The cable is thin and has a small loop or bend in the middle.	 A line drawing of a rectangular peripheral kit. It has a slot on the top surface for a card, a small circular lens or sensor on the front, and a small rectangular port on the side. The device is shown from a three-quarter perspective.
a. OTG cable	b. Peripheral kit (1D/2D scanner, Fingerprint, Smart card reader, 3G Board )

## 2 System View

### 2-1 Front View

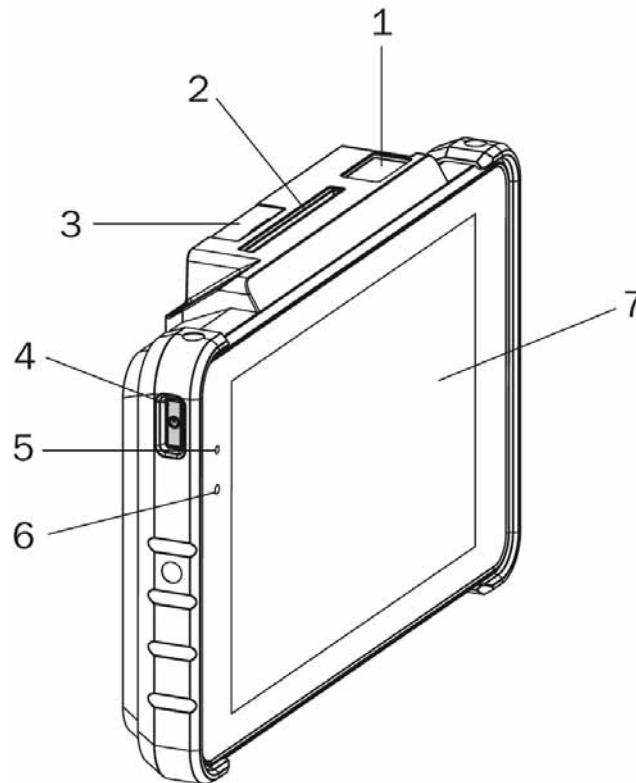

No.	Description
1	1D/2D Scanner (optional; will be installed to system prior to shipping)
2	Smart card reader (optional; will be installed to system prior to shipping)
3	3G card slot (optional; will be installed to system prior to shipping)
4	Power button
5	Power LED light indicator
6	Ambient light sensor
7	TFT LCD

## 2-2 Rear View

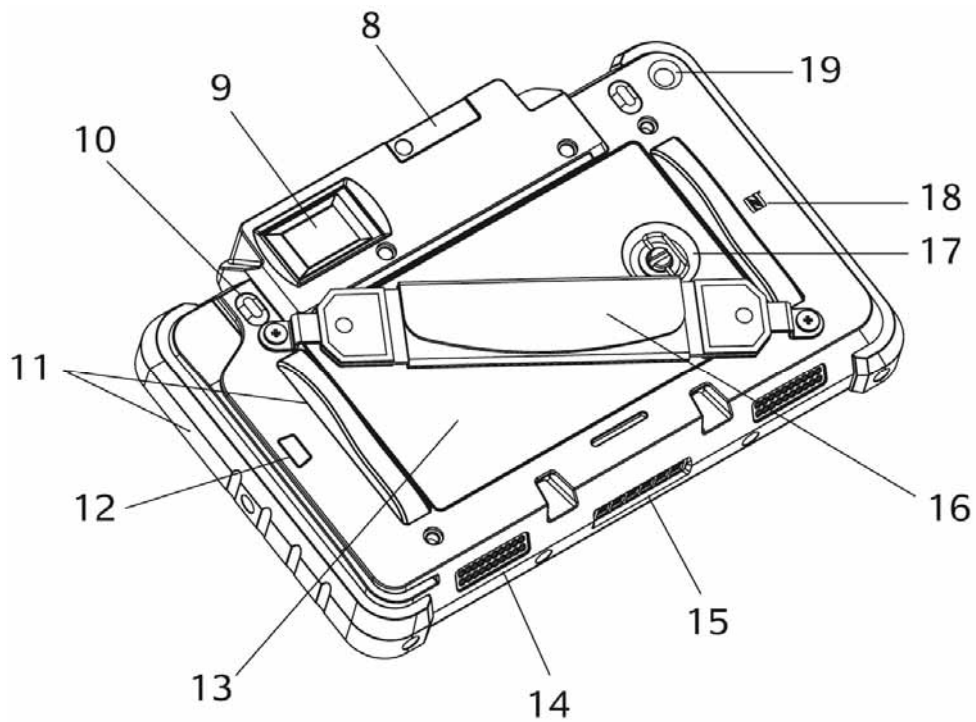

No.	Description
8	3G card slot (optional; will be installed to system prior to shipping)
9	Fingerprint (optional; will be installed to system prior to shipping)
10	Programmable button(default scan button)
11	Protection bumper
12	MSR
13	Battery cover
14	Speaker
15	Power charging slot
16	Hand strap
17	Pen screw
18	NFC logo
19	Camera

## 2-3 Specification

System	P263	P265
Motherboard	<b>D41</b>	
CPU	Baytrail - T CR Z3735F	
System Memory	2GB for Windows DDR3L	
Flash Memory	32G for Windows eMMC	
<b>LCD Touch Panel</b>		
LCD Size	7"	10.1"
Interface	MIPI	
Resolution	1280 x 800	1920 x 1200
Touch Screen	P-CAP 5 points Multi-touch	
<b>Wireless Networking</b>		
Wireless LAN	<b>802.11 a/b/g/n/ac, 2.4G/5GHz</b>	
Bluetooth	4.0+LE, Class 2	
NFC	1	
Cellular Network	3G/ HSDPA/ HSUPA	
<b>Expansion I/O Ports</b>		
Micro SD Socket	1	
DC input	6 pad	
<b>Audio</b>		
Speaker	1 x 1W Speaker	2 x 1W Speaker
<b>Control / Indicator</b>		
Power Button	1	
Sensor	G-sensor, Ambient Light Sensor	
Vibrator	Built-in vibrator motor	
LED Indicator	1 (Battery status indicator)	
<b>Peripherals</b>		
Camera	5MP ( Rear side)	
MSR	3 Tracks MSR	
Hand strap	1	
IC card reader	Smart IC Card Reader (Optional)	
Scanner	1D/2D Barcode Scanner (Optional)	
Fingerprint	1	
<b>Cradle</b>		
USB Port	Micro-USB 2.0 x 1	
Power Adapter	5V/2A , 10W	
<b>Battery &amp; Power</b>		

System	P263	P265
Motherboard	<b>D41</b>	
Battery	8000 mAh, 3.7V, 29.6 Wh <sup>*2</sup>	
<b>Certificate</b>		
EMC & Safety	FCC Class B / CE Mark / UL	
<b>Environment</b>		
Sealing	IP54 (display side)	
Fall Security	1.2 m drop, 1 drop per side at 25°C <sup>*3*4</sup>	
Operating Temperature (Not in charging mode)	0°C ~ 40°C (32°F ~ 104 °F)	
Operating Temperature (running charging mode)	0°C ~ 35°C (32 °F ~ +95 °F)	
Storage Temperature	-10°C ~ 45°C (14°F ~ 114°F)	
Operating Humidity	20% - 80% RH non-condensing	
Storage Humidity	20% - 80% RH non-condensing	
<b>Size</b>		
Dimension	203.9 x 127.9 x 35.3mm (8.0" x 5.0" x 1.3")	268 x 176 x 35.5mm (10.6" x 6.9" x 1.4")
Weight	665g (1.47lbs)	930g (2.08lbs)
Weight (with all peripherals)	Max 690g (1.52lbs)	Max 990g (2.18lbs)
<b>OS Support</b>	Window 8.1 embedded industry Pro & Window 10 embedded IoT Ent. (Support 32bit only)	

- \*1. Tablet LED indicator: Green light-Full charged / Orange light- Charging / Red flash light- Low battery / Red light- Critical low battery.
- \*2. The actual operation hours will be affected by real application environment.
- \*3. The drop durability height is a measured value resulting from actual testing. It does not necessarily guarantee the product from damage.
- \*4. The drop durability height does not include the protruding parts.

# 3 Getting Started

## 3-1 Power On/Off the System

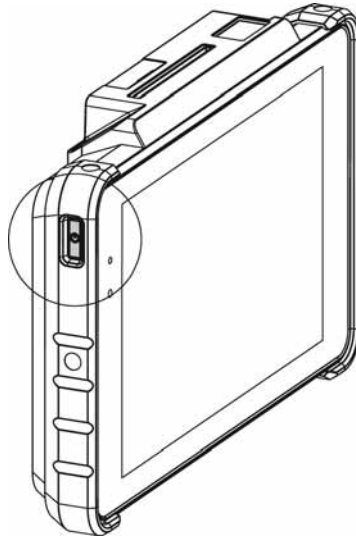

1. Push the power button to turn on the system and hold 4~5 seconds to turn off the system.

Note: For best touch performance, remove the protective plastic overlay from the LCD screen by peeling it away from one of the corners. Be sure to use a soft pointing device or finger tip to avoid scratching the screen during normal use.

## 3-2 Installing the Hand Strap

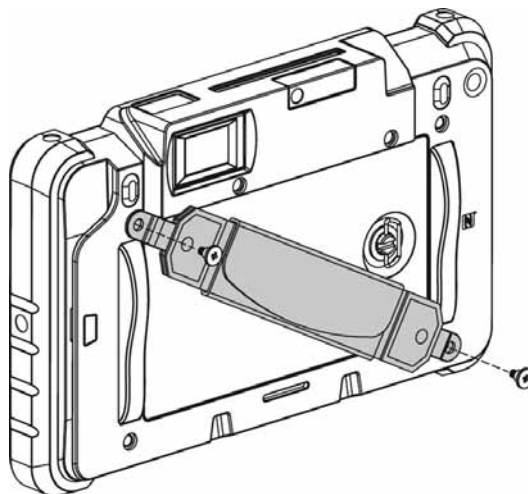

1. Attach the hand strap to the back of the system and fasten the screws (x2) to secure it.

### 3-3 Replacing the Battery

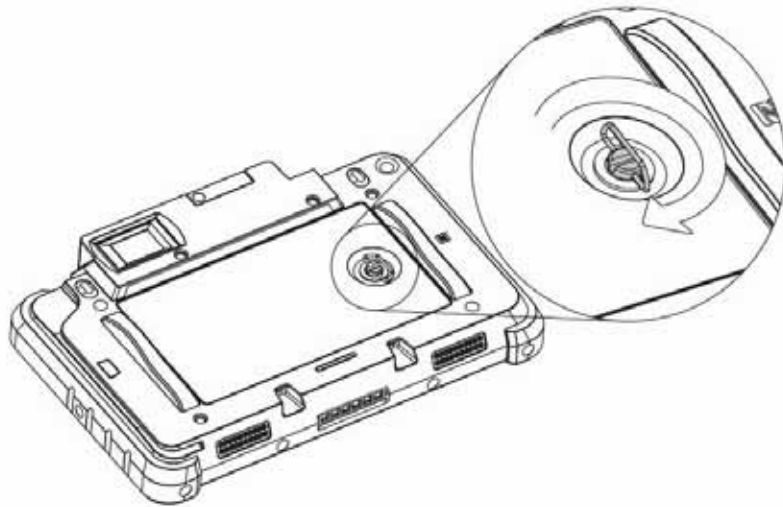

1. Loosen the pen screw counter-clockwise on the battery cover.

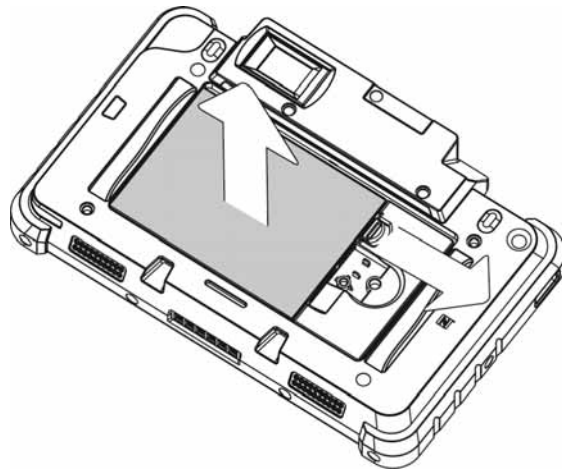

2. To remove the battery pull the plastic tab aside and gently lift the battery out of the system.

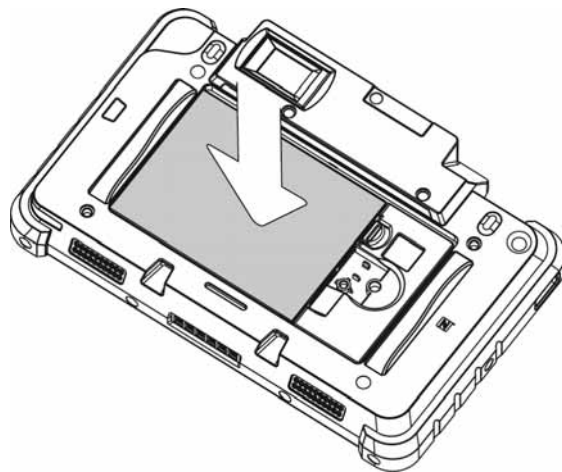

3. To install the battery put the battery in the slot and push until the battery clicks into place.



### 3-4 Using the Charging Cradle

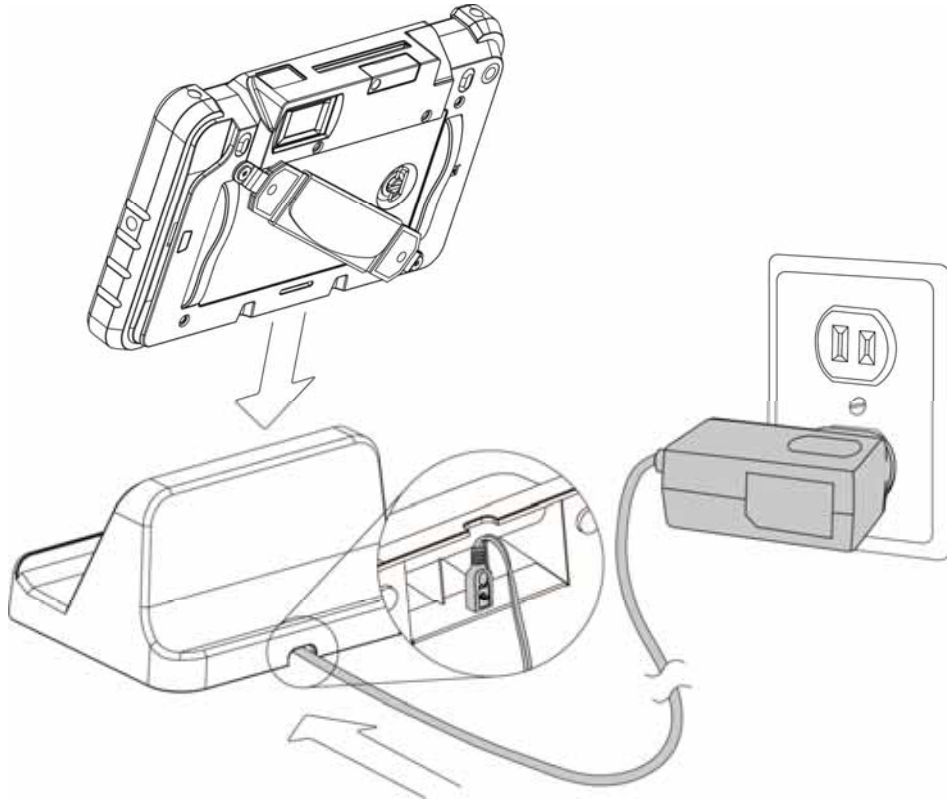

1. Connect the USB-AC adapter to the connector on the bottom of the cradle charger and the power outlet.

### 3-5 Connect to Other Device

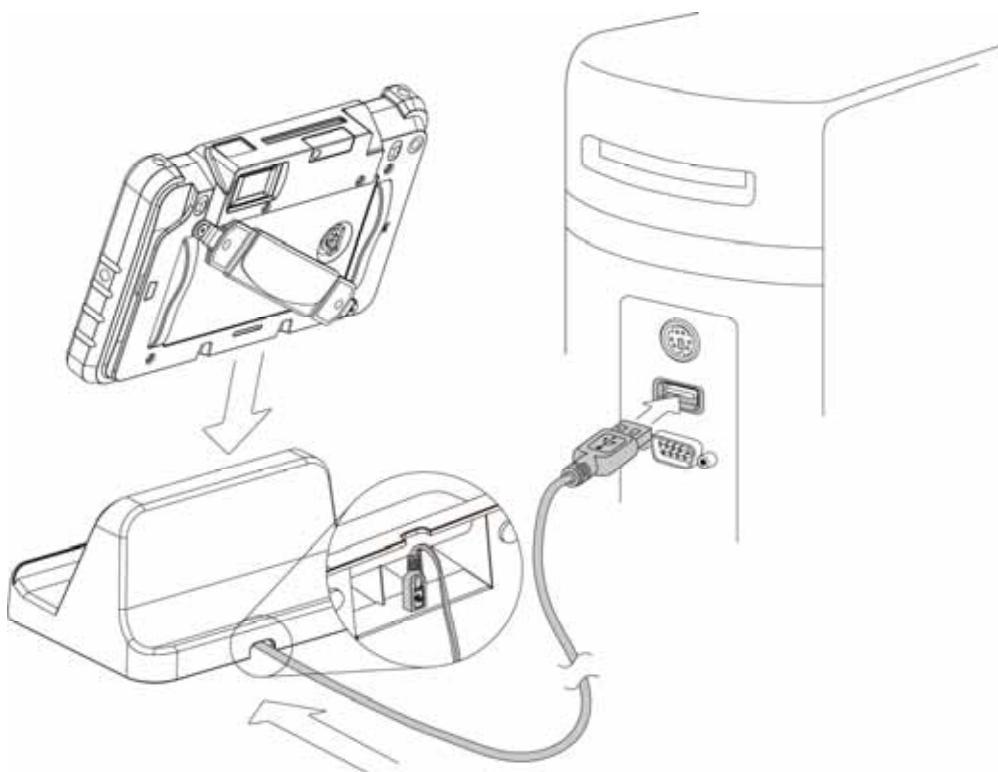

1. Connect the OTG USB cable to the connector on the bottom of the cradle charger and connect the other end to a PC to synchronize the two devices.

## 3-6 Replacing a Micro SD Card

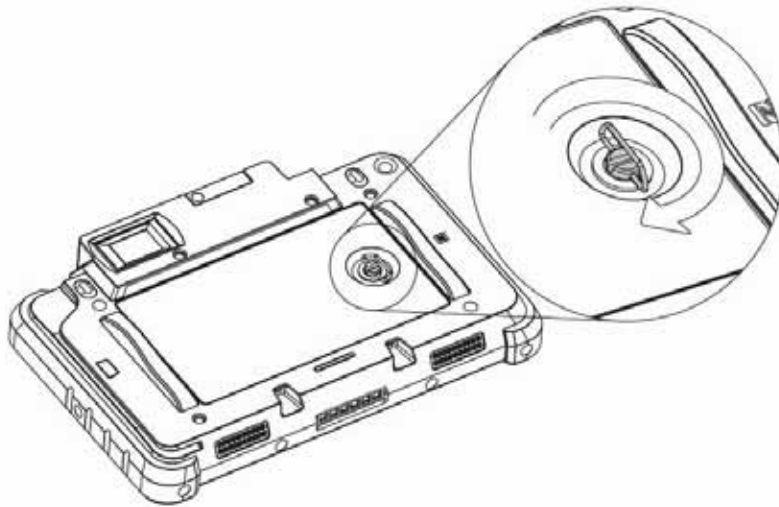

1. Loosen the pen screw counter-clockwise on the battery cover.

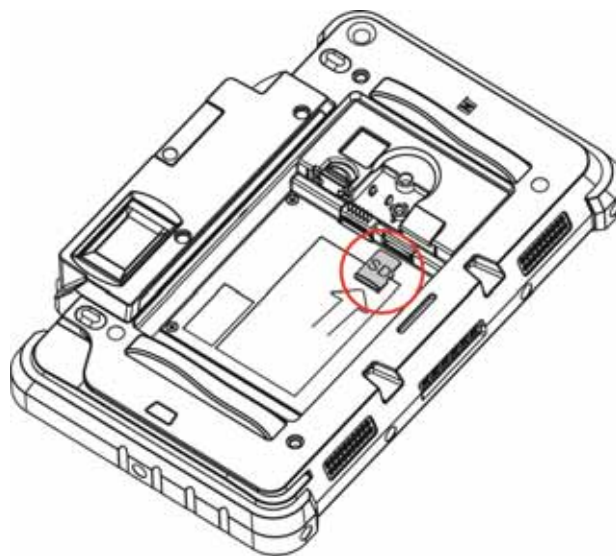

2. To install a Micro SD card insert the Micro SD card into slot until it snaps in place.
3. To remove the Micro SD card just push the card again and slide it outwards.

### 3-7 Installing the 3G Card

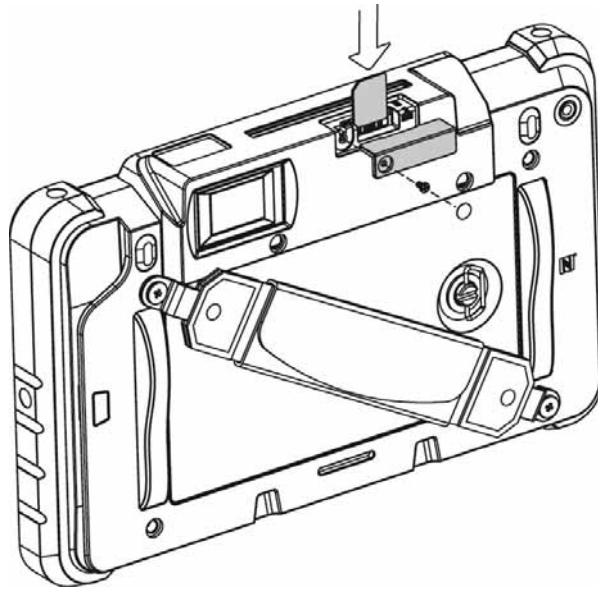

1. Loosen the screw(x1) to remove cover of 3G card slot.
2. Inset the 3G card until it snaps in place. Finally screw the cover back.

# 4 Application Programming Interface

- **Operating System**

The API operation has been verified with the following operating systems:

- Microsoft Windows 8 32 bit

- **EC Version**

11 or later version can support

## 4-1 OpenFunKeyLib

### [Function]

This opens the Function Key API service.

### [Format]

```
int OpenFunKeyLib(char *FunKeyControlVersion)
```

### [Argument]

uchar \*FunKeyControlVersion    get EC version.

### [Return Value]

If opening service was successful, the return SV\_ERROR\_SUCCESS value, If there is can't found EC control, the SV\_ERROR\_FAILED\_NO\_FOUND\_DEVICE are returned, if return SV\_ERROR\_FAIL the service can't form EC control get return value.

### [Explanation]

Before using an API function other than this function, it is necessary that this function be executed first.

### [Example]

```
char HIDVer[100];
```

```
If(OpenFunKeyLib(HIDVer) == SV_ERROR_SUCCESS)
    //Normal Processing
    Printf(HIDVer);
else
    //Error Processing
```

## 4-2 SetFunKey1

### [Function]

Set Button 1 output key.

### [Format]

```
int SetFunKey1(const char* SetKey, bool ButtonEnable)
```

### [Argument]

const char\* SetKey    Set button1 output key.

bool ButtonEnable    Enable/Disable key output.

Trur is enable, False is disable.

### [Return Value]

If set value successful, the return SV\_ERROR\_SUCCESS value. If there is an error, the SV\_ERROR\_FAIL are returned.

### [Explanation]

None

### [Example]

```
DWORD Rtn;
```

```
  Rtn = SetFunKey1("A", true); //Set button 1 output 'A'
```

## 4-3 SetFunKey2

### [Function]

Set Button 2 output key.

### [Format]

```
int SetFunKey2(const char* SetKey, bool ButtonEnable)
```

### [Argument]

const char\* SetKey    Set button1 output key.

bool ButtonEnable    Enable/Disable key output.

Trur is enable, False is disable.

### [Return Value]

If set value successful, the return SV\_ERROR\_SUCCESS value. If there is an error, the SV\_ERROR\_FAIL are returned.

### [Explanation]

None

### [Example]

```
DWORD Rtn;
```

```
//Set button 2 is barcode reader's trigger
```

```
Rtn = SetFunKey2("<BarCode>", true);
```

## 4-4 Appendix A: KeyMap.ini

[ASCII]

32=2C	44=36	56=25	68=07	80=13	92=31	104=0B	116=17
33=1E	45=2D	57=26	69=08	81=14	93=30	105=0C	117=18
34=34	46=37	58=33	70=09	82=15	94=35	106=0D	118=19
35=20	47=38	59=33	71=0A	83=16	95=2D	107=0E	119=1A
36=21	48=27	60=36	72=0B	84=17	96=35	108=0F	120=1B
37=22	49=1E	61=2E	73=0C	85=18	97=04	109=10	121=1C
38=24	50=1F	62=37	74=0D	86=19	98=05	110=11	122=1D
39=36	51=20	63=38	75=0E	87=1A	99=06	111=12	123=2F
40=26	52=21	64=1F	76=0F	88=1B	100=07	112=13	124=31
41=27	53=22	65=04	77=10	89=1C	101=08	113=14	125=30
42=25	54=23	66=05	78=11	90=1D	102=09	114=15	126=35
43=2E	55=24	67=06	79=12	91=2F	103=0A	115=16	



[FunctionKey]

{Return}=28	{F11}=44	{NumLock}=53	{KeypadPointDelete}=63
{Escape}=29	{F12}=45	{KeypadDivision}=54	{KeyboardPower}=66
{Backspace}=2A	{PrintScreen}=46	{KeypadMultiplication}=55	{KeyboardVolUp}=80
{Tab}=2B	{ScrollLock}=47	{KeypadSubtraction}=56	{KeyboardVolDn}=81
{Space}=2C	{Break}=48	{KeypadAdd}=57	{CapsLock}=82
{CapsLock}=39	{Pause}=48	{KeypadEnter}=58	{NumLock}=83
{F1}=3A	{Insert}=49	{Keypad1End}=59	{ScrollLock}=84
{F2}=3B	{Home}=4A	{Keypad2Down}=5A	{LeftCtrl}=E0
{F3}=3C	{PageUp}=4B	{Keypad3PageDn}=5B	{LeftShift}=E1
{F4}=3D	{Delete}=4C	{Keypad4Left}=5C	{LeftAlt}=E2
{F5}=3E	{End}=4D	{Keypad5}=5D	{RightCtrl}=E4
{F6}=3F	{PageDown}=4E	{Keypad6Right}=5E	{RightShift}=E5
{F7}=40	{RightArrow}=4F	{Keypad7Hoem}=5F	{RightAlt}=E6
{F8}=41	{LeftArrow}=50	{Keypad8Up}=60	
{F9}=42	{DownArrow}=51	{Keypad9PageUp}=61	
{F10}=43	{UpArrow}=52	{Keypad0Insert}=62	

## [MediaKey]

(ScanNextTrack)=00B5	(VolumeDown)=00EA	(WWWSearch)=0221
(ScanPreviousTrack)=00B6	(BassUp)=0152	(WWWHome)=0223
(Stop)=00B7	(BassDown)=0153	(WWWBack)=0224
(Play/Pause)=00CD	(TrebleDown)=0155	(WWWForward)=0225
(Mute)=00E2	(MediaSelect)=0183	(WWWStop)=0226
(BassBoost)=00E5	(Mail)=018A	(WWWRefresh)=0227
(Loudness)=00E7	(Calculator)=0192	(WWWFavorites)=022A
(VolumeUp)=00E9	(MyComputer)=0194	

## [SpecialKey]

<BarCode>=1111

Requirements in

AT/BE/BG/CZ/DK/EE/FR/DE/IS/IE/IT/EL/ES/CY/LV/LI/LT/LU/HU/MT/NL/NO/PL/PT/RO/SI/SK/TR/FI/SE/CH/UK/HR.5150MHz~5350MHz is for indoor use only

SAR is measured with the device at 0 mm to the body, while transmitting at the highest certified output power level in all frequency bands of the device. The maximum SAR value is 0.206 W/kg (body) averaged over 10 gram of tissue.

This equipment should be installed and operated with a minimum distance of 0 cm between the radiator and your body.

WARNING: This is a class A product. In a domestic environment this product may cause radio interference in which case the user may be required to take adequate measures.

Radio Type / Description		Transmitter Frequency (MHz)	Maximum Output Power
NFC	NFC	13.56	0.03dBuA/m @3m
Bluetooth	BR+EDR	2402 ~ 2480	5.79dBm
	Low Energy	2402 ~ 2480	6.59dBm
WLAN 2.4G	802.11b	2412 ~ 2472	17.89dBm
	802.11g	2412 ~ 2472	18.69dBm
	802.11n 20	2412 ~ 2472	18.89dBm
	802.11n 40	2422 ~ 2462	18.89dBm
WLAN 5G	802.11a	5150 ~ 5350	16.69dBm
		5470 ~ 5725	17.30dBm
	802.11n_20M 802.11ac_20M	5150 ~ 5350	15.87dBm
		5470 ~ 5725	16.56dBm
	802.11n_40M 802.11ac_40M	5150 ~ 5350	16.52dBm
		5470 ~ 5725	15.97dBm
	80211ac_80M	5150 ~ 5350	14.92dBm
		5470 ~ 5725	15.62dBm

# EU Declaration of Conformity (DoC)

**Hereby we,**

Name of manufacturer: FLYTECH TECHNOLOGY CO., LTD.  
 Address: No. 168, Sing-ai Rd., Neihu District, Taipei City 11494,  
 Zip code & City: Taipei City 11494,  
 Country: Taiwan, R.O.C.  
 Telephone number: 886-2-8791-4988

**declare that this DoC is issued under our sole responsibility and that this product:**

Product description: Mobile PC  
 Type designation(s): P263(D41)  
 Trademark: FLYTECH  
 Batch / Serial number: \_\_\_\_\_

**Object of the declaration** (further identification of the radio equipment allowing traceability; it may include a color image for the identification of the radio equipment):



**is in conformity with the relevant Union harmonization legislation:**

Radio Equipment directive: **2014 / 53 / EU**  
 and other Union harmonization legislation where applicable:

RoHs Directive: 2011/65/EU  
 \_\_\_\_\_

**with reference to the following standards applied:**

EN300 328 v2.1.1:2016 ; EN301 893 v2.1.1:2017 ; EN300 330 v2.1.1:2017  
EN50566:2013/EN62209-2:2010/EN62479:2010  
EN55032:2012/AC:2013 ; EN55024:2010  
EN301 489-1 v2.2.0:2017-03(Draft) / EN301 489-3 v2.1.1:2017-03(Final Draft) / EN301 489-17 v3.2.0:2017-03(Draft) / / EN301 489-52 v1.1.0:2016-11(Draft)  
EN60950-1:2006+A11:2009+A1:2010+A12:2011+A2:2013

**The Notified Body Telefication B.V., with Notified Body number 0560 performed:**

*Modules: B+C*

**Where applicable:**

The issued the EU-type examination certificate: [*note certificate number*]

Description of accessories and components, including software, which allow the radio equipment to operate as intended and covered by the DoC:

.....

**Signed for and on behalf of:**

**Taipei City / Aug. 18, 2017**

**Avin**

\_\_\_\_\_  
Place and date of issue

\_\_\_\_\_  
Name, Function, signature