

SKYWELL

User Manual

Atmospheric Water Cooler

Model:

Spec:

Serial Number:

Admin PIN:

Date of Purchase:

Please register this unit at
Skywell.com
to activate warranty and get
the latest product updates.

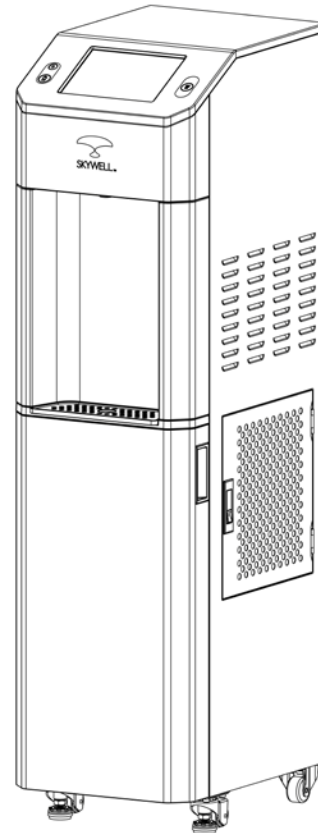

SAVE THIS MANUAL FOR FUTURE USE

When using electrical appliances, basic safety precautions should be followed in order to reduce the risk of fire, electric shock and injury to persons or property. This manual contains important information describing how to safely set up, use and maintain your Skywell water cooler.





WARNING To reduce risk of injury and property damage, please read this entire manual before assembling, installing & operating the dispenser. Failure to execute the instructions in this manual could cause personal injury or property damage.

QUICK SETUP AND INSTALLATION



Excessive Weight Hazard. Use two or more people to move and install the water cooler.

① Find the perfect spot for your Skywell on a hard level surface. It should have 4 inches of space in each direction to ensure proper air flow and operation.

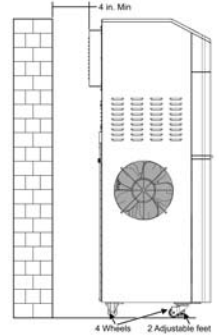

② Remove the Skywell from the box and recycle the box. Both we and the environment appreciate it! Skywell takes recycling and conservation efforts to heart. We have instituted the “**Skywell Cares**” initiative is a program Skywell has instituted for when it is time to retire your 5T1.5 unit. A Skywell Cares technician will retrieve your unit, at no cost, and recycle a significant portion of the materials to minimize waste and environmental impact.

③ **The drip tray may be removed and installed without opening the front door. The drip tray cover may be removed to clean the drip tray. When re-installing the drip tray, insert it downward securing it into its docking point below the dispense point.**

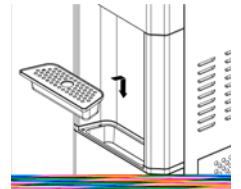

④ (OPTIONAL) If your Skywell was not installed by a Skywell technician, you may want to flush the filters to avoid a chalky taste in your first few gallons of generated water. See page 6 for instructions.

⑤ Plug the Skywell into a standard power outlet and let it begin making water.



WARNING The unit should be upright for 4 hours prior to plugging in. Plugging in shortly after the unit has been on another side can damage the compressor.

NOTE: WHEN YOUR UNIT IS PLUGGED IN FOR THE FIRST TIME, IT MAY TAKE UP TO 6 HOURS FOR COLD WATER TO REACH ITS COLDEST POINT.

KEY SAFETY CONSIDERATIONS



WARNING Plug the Skywell 3-prong grounded plug into a standard 3-prong grounded AC 120V, 60Hz outlet **ONLY**. The Skywell must be properly grounded. Consult with an electrician if necessary.



WARNING The Skywell dispenses water as hot as 207° Fahrenheit (97° Celsius). Use caution when dispensing hot water and do not allow children to dispense hot water without supervision.

WELCOME TO YOUR SKYWELL

Congratulations on your selection of an advanced state-of-the-art Atmospheric Water Generator, water cooler, and multi-purpose dehumidification unit.

Your Skywell 5T1.5 uses a fan to draw moist air into the machine, where it passes through a chilled evaporator coil that cools the air to below the dew point. The resulting condensation is collected in a tank at the bottom of the machine, and purified for your use using a proprietary filtration system, UV light treatment, and ozone protection.

THE SKYWELL MISSION

The company started with a simple goal: To change how the world thinks about drinking water.

Clearly, our planet needs a better way to create and dispense drinking water—a new approach that’s convenient for consumers, yet respectful of our environment. No plastic bottles, no delivery trucks, no added chemicals or unnecessary water waste. And a cost that’s comparable to traditional methods, including bottled water delivery and single-use bottles. This new approach had to be self-contained—no plumbing required—with super-efficient filtering, very low maintenance, and very high purity.

The solution: revolutionary technology that literally creates water from the air. Skywell takes our planet’s most plentiful resource—the air around us—condenses and filters it, and creates one of our most precious resources: pure, clean drinking water. We call it *air water*. To produce it, all you need is a Skywell and a standard electrical outlet.

Skywell is committed to making a positive impact on our world’s water crisis. We’re empowering people to control their own water supply—and in the process, to act in a socially responsible manner regarding the Earth’s waning supply of clean drinking water.

The time is right for Skywell. It’s here, now. And for us, it’s not just a product; it’s a mission.

CONTENTS OF THIS MANUAL

Quick Install Guide	2
Welcome to Your Skywell	3
Safety Precautions.....	4
Product Features	5
Parts & Features Specifications.....	5
Cleaning Prior to Initial Use.....	6
Operation	6
Using the touchscreen	7
Proper Care & Cleaning	8
How to Install Filters	9
Troubleshooting.....	10
Limited Warranty	11
Quick Reference Guide	Back Cover

SAFETY PRECAUTIONS



Ensure you read this entire manual before operating the machine for the first time.



This product dispenses water at very high temperatures. Failure to use properly can cause personal injury.

When operating this dispenser, always exercise basic safety precautions, including the following:

1. Prior to use, this dispenser must be properly assembled and installed in accordance with this manual.
2. This dispenser is intended for water dispensing only. Do NOT use other liquids. Do NOT use for other purposes. Warranty is void if used to directly dispense any other liquids.
3. For indoor use only. Keep water dispenser in a dry place away from direct sunlight. Do NOT use outdoors.
4. Install and use only on a hard, flat and level surface.
5. Do NOT place dispenser in an enclosed space or cabinet.
6. Do NOT operate dispenser in the presence of explosive fumes.
7. Position the back of the dispenser no closer than 4 inches from a wall and permit free airflow between wall and the dispenser. There must be at least 4 inches of clearance on the sides of the dispenser to permit airflow.
8. Use only properly grounded outlets. Do not use an extension cord with your water dispenser.
9. Always grasp the plug and pull straight out from the outlet. Never unplug by pulling on the cord.
10. Do NOT use this dispenser if the cord becomes frayed or otherwise damaged.
11. To protect against electric shock, do NOT immerse the cord, plug, or any other part of the cooler in water or other liquids.
12. Ensure the dispenser is unplugged prior to cleaning or changing filters.
13. Never allow children to dispense hot water without proper and direct supervision.
14. Service should be performed only by a certified technician. Please contact us at 1-844-SKYWELL (759-9355) for assistance.



Do not attempt to adjust the ozonator. Ozone is released in very small quantities that have been verified as safe. Attempting to adjust the ozonator may release more ozone than prescribed.



Electrical Shock Hazard

1. Plug your Skywell into a grounded 3-prong outlet only.
2. Do not remove ground prong from Skywell power cable.
3. Do not use an adapter or extension cord.
4. Failure to follow these instructions can result in death, fire, or electrical shock.

A 120 volt, 60 Hz, AC only, 15- amp, fused electrical supply is required. A time-delay fuse or circuit breaker is recommended. Do not overload the circuit, and provide a separate circuit, if required, to serve only this appliance. The Skywell must be plugged into a mating, 3 prong, grounding-type outlet, grounded in accordance with local codes and ordinances. In the event of a malfunction or breakdown, grounding will reduce the risk of electrical shock by providing a path of least resistance for electric current. If a mating outlet is not available, it is the personal responsibility and obligation of the customer to have the properly grounded outlet installed by a qualified electrician. Do not ground to a gas pipe. Do not have a fuse in the neutral or ground circuit.

IMPORTANT: Do NOT Return Dispenser To Store.

If you have a question or problem, please contact 1-844-SKYWELL (759-9355) for assistance.

PRODUCT SPECIFICATIONS

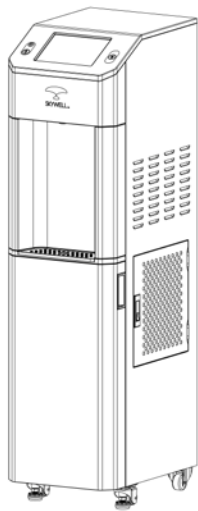

Power rating	AC120V / 60Hz / 13A
Refrigerant Types	R-134a & R-410a
Cold Water Power	70W
Cold water capacity / Hour	0.8L / 0.21Gallons
Hot Water Power	850W
Hot water capacity / Hour	7.2L / 1.9Gallons
Dispense Temp. Range	39°F - 203°F
Collection tank capacity	6 L / 1.6 Gallons
Cold tank capacity	10 L / 2.5 Gallons
Hot tank capacity	0.8 L / 0.21 Gallons
Dimensions	123.6 H × 32 W × 50.2 D (cm) 48.7 H × 12.6 W × 19.8 D (inch)
Net Weight	139lbs / 63Kg

PARTS & FEATURES

- Child Safety Lock ①
- Tap button: Hot Water ②
- Tap button: Cold Water ③
- Water Dispensing Point ④
- LED Night Lights ⑤
- Drip Tray ⑥
- Water Filter Door ⑦
- Interactive Touchscreen ⑧
- Vent door ⑨
- Water Filter ⑩
- Water Collection Tank ⑪
- Power Cord ⑫
- Drain Plug ⑬
- Condenser ⑭
- UV light ⑮
- UV light ⑯

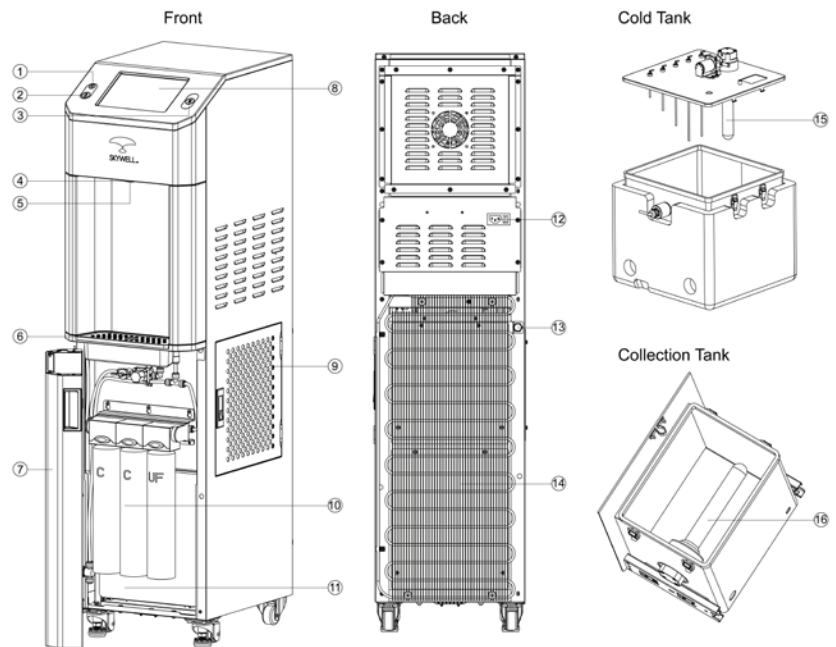

REPLACEMENT PARTS LIST

Complete Filter Kit	FW555	Air Filter	FA006
Sediment Filter	FW011	Touch Screen Device	TZ121
Pre-Carbon Filter	FW021	UV Light	FW101
UF Membrane Filter	FW031	Hot Water Button	AB051
Alkaline Filter (special order)	FW041	Cold Water Button	AB061

OPERATING AND USING YOUR SKYWELL

WATER FILTER BREAK-IN PRIOR TO USE (OPTIONAL)

While the very first drops of Skywell water will be clean, fresh water, the first few gallons may have a less than optimal taste while the filters break in. In order to avoid this Skywell recommends that the first 10 gallons produced not be consumed. (Feel free to water plants or otherwise use the water as you see fit.) After the first ten gallons, or the cold tank filling twice and being completely dispensed, the filters will have had ample water passed through them for a complete break-in. Your Skywell water will now not only be clean and fresh, but taste pure, without the potential chalkiness associated with brand new water filters.

Dispensing Cold Water

Note: After setup, it will take up to 6 hours to get the water to its maximum cold temperature. During this time, the compressor may run continuously. Cold water availability for dispense will be aligned with overall water production, which is driven by the ambient conditions.

1. Position your bottle, glass, pitcher or cooking pot securely below the dispensing point indicated by the [Skywell Mark](#) at the front of the machine.
 - To avoid splashes, hold the cup as close to the tap as possible.
2. Press and hold the cold water control downward to start dispensing water.
3. Release the control once the desired fill level is achieved.



Dispensing Hot Water

Note: After setup, the Skywell is able to heat generated water to hot water (up to 207 degrees Fahrenheit) within 15-20 minutes. Hot water availability for dispense will be aligned with overall water production, which is driven by the ambient conditions.

1. Position your bottle, glass, pitcher or cooking pot securely below the dispensing point indicated by the [Skywell Mark](#) at the front of the machine.
2. Press the red unlock button to unlock hot water dispensing (you should hear a beep)
3. Press and hold the hot water button to start dispensing water.
4. Release the control once desired the fill level is achieved.



THE SKYWELL

HYDRATION APP

- Button: Expand Menu
- Button: Go to Home Screen
- Button: User Profiles
- Button: Cause Info
- Button: Settings Menu
- Button: Help Screen
- Button: Quiet Mode

Level

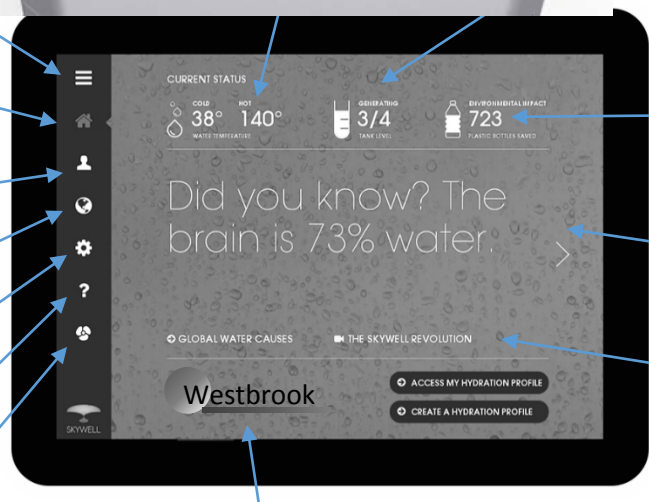



- Total .5L plastic bottles saved to date from use of the
- Water Facts
- Skywell Cause Video

Custom Logo

SETTING PRODUCTION SCHEDULE

To set up a custom schedule for producing water, first go to the Settings Menu. In the lower-right-hand corner there are two options:

-  Schedule Daily Generation – use to set regular production schedule. You can set up to 4 different time periods and have each produce water at different rates. “MAX” will produce the most water but also have the most “fan noise.”
-  Change Today’s Schedule – similar to setting Daily Generation but only applies to the calendar day for which it is set.



CREATING A USER PROFILE

To engage a new user, have them dispense water into a glass. After dispensing has finished, the screen will announce how much water has been dispensed and there will be a button in the lower-right-hand corner offering to “Create A New Hydration Profile”. Pressing this button will prompt the user to create a user name and PIN number. After this point, any water dispensed can be added to this profile.

ADDING WATER DISTRIBUTION TO A USER PROFILE

After dispensing has finished, the screen will announce how much water has been dispensed and there will be a button in the lower-right-hand corner offering to “Add to My Hydration Profile”. Press this button, select the desired user profile, and enter the PIN to complete.

ADDING CUSTOM LOGOS

A Skywell representative can help load your custom logos or brand messaging to the touchscreen display.

CLEANING AND CARE

Disinfecting the dispensing point

Time Required: 5 minutes

Recommended Frequency: Once per month

The Skywell machine is self-cleaning internally, but the dispensing point for the water interacts with the outside environment. Regular use of the hot water will generally disinfect the dispensing point, but extra care at the dispensing point can ensure you always have the cleanest water possible.

- 1) Use non-toxic cleaning agent to clean the nozzle
- 2) Dispense cold water and then hot water for at least 3 seconds each. Capture this water for non-potable use.

Cleaning the collection tank

Time Required: 15 minutes

Recommended Frequency: Once per month

Because the collection tank by necessity interacts with the environment in order to collect water, it can over time develop buildup. While the Skywell's filtration and water quality systems will ensure your water remains clean and safe to drink regardless, such buildup can shorten the life of the water filters and reduce the efficiency of the system. Therefore regular cleaning is important to ensure optimal performance.

- 1) Unplug your Skywell
- 2) Open the front cabinet door, and swivel the water filters in an upward motion until they are parallel to the floor.
- 3) Use the handle on the collection tank to pull it forward to help, but be careful to not put stress on the wires connected to the lid. Carefully remove the lid of the collection tank by lifting straight up.
- 4) Empty contents of tank. This is unfiltered water, but it can still be used for non-potable purposes, such as watering plants.
- 5) Use a non-toxic cleaning agent to wipe down all of the internal surface area of the collection tank.
- 6) Rinse the collection tank to remove any traces of cleaning agent.
- 7) Return collection tank into the Skywell, carefully reattach lid (NOTE: Ensure lid is properly lined up. If lid is reattached out of place, the machine may leak collected water over time).
- 8) Lower water filters to vertical position, plug Skywell back in.

Cleaning the air filter

Time Required: 5 minutes

Recommended Frequency: Once per month

- 1) Open the fan door by pressing the release latch
- 2) Remove the air filter
- 3) Rinse the air filter until water passing through it comes out clear
- 4) Return the air filter to its compartment and latch the door shut.

Note: The Air Filter comes with a lifetime warranty. If your air filter breaks due to manufacturing error, Skywell will replace it for free. If your air filter breaks for misuse or accidental damage, a replacement can be ordered by calling the Skywell Service Department at 844-SKY-WELL

Replacing water filters

Time Required: 15 minutes

Recommended Frequency: Quarterly

NOTE: If you purchased a service plan through Skywell, a certified technician will perform all replacements of filters for your machine.

- 1) Unplug your Skywell and wait for any noises to cease.
- 2) Open the front cabinet door to expose the filter manifold.
- 3) Place a bowl or other device below the filters to catch any water that may drip out as a result of releasing filters.
- 4) From left to right, replace the filters one at a time:

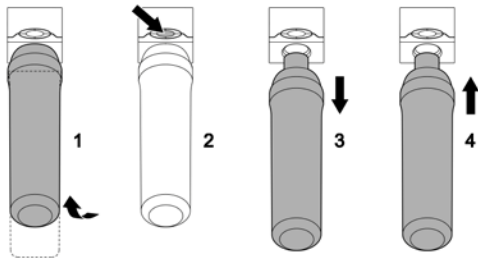
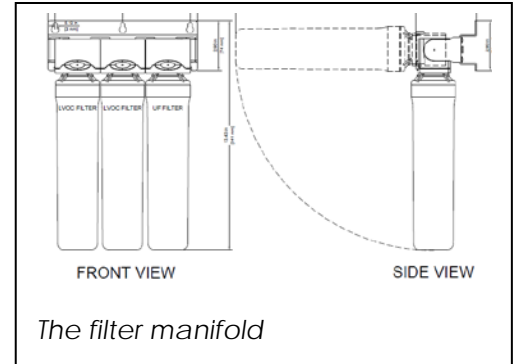

1. Swivel existing filter up until it is parallel to the ground.
2. **Pull out the filter element**
3. **Insert new filter and until it locks into place.**
4. Gently lower the new filter to its vertical position.

- 5) Once all the filters have been replaced, you may wish to flush them to provide any taste inconsistency while they are being broken in. See instructions for filter flushing on Page 6.
- 6) Close cabinet door and plug Skywell back in.

Replacing the UV System

Time Required: 20 minutes

Recommended Frequency: Every 8-9 months

It is recommended that a Skywell technician perform this maintenance function. Please contact Skywell for support.

IMPORTANT: Do NOT Return Dispenser To Store.
 If you have a question or problem, please contact 1-844-SKY-WELL for assistance.

TROUBLESHOOTING TIPS

PROBLEM	POSSIBLE CAUSES	HOW TO SOLVE
No hot water	1. There is no power to the outlet, machine is not plugged in, or power switch is off 2. Water levels are too low 3. Pump is not working	1. Ensure that the power outlet has power by testing another safe device. 2. Allow machine to generate additional water, or you can expedite by adding clean water to the collection tank. 3. Add water to collection tank and wait for 30 minutes while machine is plugged in. If there is still no water being dispensed from hot tank, call for service.
No cold water	1. There is no power to the outlet, machine is not plugged in, or power switch is off 2. Water levels are too low 3. Water has had insufficient time to cool. 4. Potential compressor cooling system problem if there is no cold water and unit doesn't cool water after one hour of running continuously. 5. Pump is not working	1. Ensure that the power outlet has power by testing another safe device. 2. Allow machine to generate additional water, or you can expedite by adding clean water to the collection tank. 3. Allow additional time for cooling, which can take multiple hours if machine has just been plugged in or is empty. 4. Check to see if the condenser coils (black tubing at the back) are radiating heat or not. If the area is not hot, call for service.
Water does not taste good	1. Water filters have not been replaced recently enough 2. Water filters are new and still being broken in. 3. Air filter is dirty 4. Collection tank needs to be cleaned	1. Replace water filters (see page 9) 2. Flush the filters (see page 6) 3. Clean the air filter (see page 8) 4. Clean the collection tank (see page 8)

IMPORTANT: Do NOT Return Dispenser To Store.
 If you have a question or problem, please contact 1-844-SKY-WELL for assistance.

- Water leaking from unit
1. Collection tank lid is not aligned correctly.
 2. Filters not seated correctly in filter manifold.
 3. Water line cracked.
 4. Level sensors are out of the tank.
1. Ensure that the lid to the collection tank is perfectly covering it and is firmly in place.
 2. Remove water filters and put back in place, ensuring tight fit (see page 9)
 3. Open cabinet door at front of unit and see if you can find a drip. Replace line if possible or call for service.

LIMITED WARRANTY

Skywell, LLC ("Vendor") warrants to the original purchaser of this dispenser, and to no other person, that if this dispenser is assembled and operated in accordance with the printed instructions accompanying it, then for a period of one (1) year from the date of purchase, all parts in such dispenser shall be free from defects in material and workmanship, and upon the primary compressor for five (5) years. Vendor may require reasonable proof of your date of purchase from an authorized retailer or distributor. Therefore, you should retain your sales slip or invoice. The Limited Warranty shall be limited to repair or replacement of parts, which prove defective under normal use and service and which Vendor shall determine in its reasonable discretion upon examination to be defective. Before returning any parts, you should contact Vendor's Customer Service Department using the contact information listed below. If Vendor confirms, after examination, a defect covered by this Limited Warranty in any returned part, and if Vendor approves claim, Vendor will replace such defective part without charge. If you return defective parts, transportation charges must be prepaid by you. Vendor will return replacement parts to original purchaser, freight or postage prepaid.

The Limited Warranty does not cover any failures or operating difficulties due to accident, abuse, misuse, alteration, misapplication, improper installation or improper maintenance or service by you or any third party, or failure to perform normal and routine maintenance on the dispenser, as set out in the User's Manual. In addition, the Limited Warranty does not cover damages to the finish, such as scratches, dents, discoloration or rust after purchase.

The Limited Warranty is in lieu of all other express warranties. Vendor disclaims all warranties for products that are purchased from seller other than authorized retailers or distributors. AFTER THE PERIOD OF THE ONE (1) YEAR EXPRESS WARRANTY (OR FIVE YEARS FOR PRIMARY COMPRESSOR), VENDOR DISCLAIMS ANY AND ALL IMPLIED WARRANTIES, INCLUDING WITHOUT LIMITATION THE IMPLIED WARRANTIES OF MERCHANTABILITY AND FITNESS FOR A PARTICULAR PURPOSE. FURTHER, VENDOR SHALL HAVE NO LIABILITY WHATSOEVER TO PURCHASER OR ANY THIRD PARTY FOR ANY SPECIAL, INDIRECT, PUNITIVE, INCIDENTAL, OR CONSEQUENTIAL DAMAGES. Vendor assumes no responsibility for any defects caused by third parties. This Limited Warranty gives the purchaser specific legal rights; a purchaser may have other rights depending upon where he or she lives. Some jurisdictions do not allow exclusion or limitation of special, incidental or consequential damages, or limitations on how long a warranty lasts, so the above exclusion and limitations may not apply to you.

Warranty is void if the electrical outlet is improperly wired to incorrectly sized circuit breaker or fuse, if not grounded properly, or wires do not have correct polarity. Use of this cooler confirms Purchasers agreement with the conditions of this warranty.

To activate this warranty, you must register your purchase at Skywell.com.

Skywell, LLC
2856 Colorado Ave
Santa Monica, CA 90404
www.skywell.com
1-844-SKY-WELL

IMPORTANT: Do NOT Return Dispenser To Store.
If you have a question or problem, please contact 1-844-SKY-WELL for assistance.

QUICK REFERENCE GUIDE

Cleaning the air filter

1. Open the air filter door
2. Remove the air filter
3. Rinse until clean
4. Return air filter and close filter door

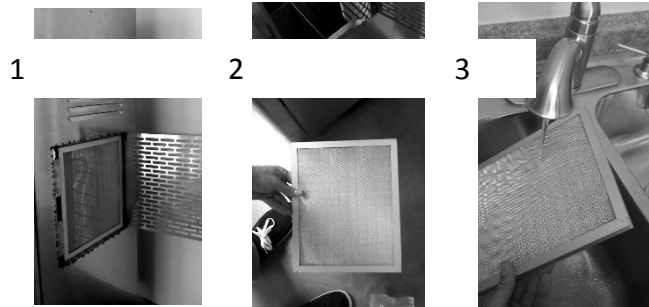

Changing the water filters

NOTE: Use only Skywell water filters. Other filters may damage the unit and will void the warranty.

- 1) Unplug your Skywell and open the front cabinet door
- 2) Place a bowl or drip tray below filters
- 3) From left to right, replace the filters one at a time:

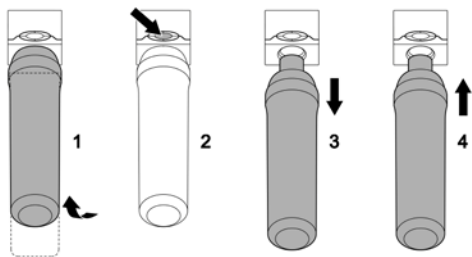

1. Swivel existing filter up until it is parallel to the ground.
2. **Pull out the filter element**
3. **Insert new filter and until it locks into place.**
4. Gently lower the new filter to its vertical position.

- 4) Once all the filters have been replaced, you may wish to flush them to provide any taste inconsistency while they are being broken in. See instructions for filter flushing on Page 6.
- 5) Close cabinet door and plug Skywell back in.

Your Skywell's Service History:

Delivered On:

Second Service:

Fourth Service:

Sixth Service:

Eighth Service:

First Service:

Third Service:

Fifth Service:

Seventh Service:

Ninth Service:

FCC Statement

This equipment has been tested and found to comply with the limits for a Class B digital device, pursuant to part 15 of the FCC Rules. These limits are designed to provide reasonable protection against harmful interference in a residential installation. This equipment generates uses and can radiate radio frequency energy and, if not installed and used in accordance with the instructions, may cause harmful interference to radio communications. However, there is no guarantee that interference will not occur in a particular installation. If this equipment does cause harmful interference to radio or television reception, which can be determined by turning the equipment off and on, the user is encouraged to try to correct the interference by one or more of the following measures:

- Reorient or relocate the receiving antenna.
- Increase the separation between the equipment and receiver.
- Connect the equipment into an outlet on a circuit different from that to which the receiver is connected.
- Consult the dealer or an experienced radio/TV technician for help.

FCC Radiation Exposure Statement

This device complies with FCC radiation exposure limits set forth for an uncontrolled environment and it also complies with Part 15 of the FCC RF Rules. This equipment must not be co-located or operating in conjunction with any other antenna or transmitter. This equipment should be installed and operated with a minimum distance of 5 millimeters between the radiator and your body.

This device complies with Part 15 of the FCC Rules. Operation is subject to the following two conditions: (1) this device may not cause harmful interference, and (2) this device must accept any interference received, including interference that may cause undesired operation.

Caution!

Any changes or modifications not expressly approved by the party responsible for compliance could void the user's authority to operate the equipment.

IC Statement

This device complies with Industry Canada licence-exempt RSS standard(s). Operation is subject to the following two conditions: (1) this device may not cause interference, and (2) this device must accept any interference, including interference that may cause undesired operation of the device.

Le présent appareil est conforme aux CNR d'Industrie Canada applicables aux appareils radio exempts de licence. L'exploitation est autorisée aux deux conditions suivantes : (1) l'appareil ne doit pas produire de brouillage, et (2) l'utilisateur de l'appareil doit accepter tout brouillage radioélectrique subi, même si le brouillage est susceptible d'en compromettre le fonctionnement.

This digital apparatus does not exceed the Class B limits for radio noise emissions from digital apparatus as set out in the interference-causing equipment standard entitled "Digital Apparatus," ICES-003 of Industry Canada.

Cet appareil numérique respecte les limites de bruits radioélectriques applicables aux appareils numériques de Classe B prescrites dans la norme sur le matériel brouilleur: "Appareils Numériques," NMB-003 édictée par l'Industrie.

Operation is subject to the following two conditions: (1) this device may not cause interference, and (2) this device must accept any interference, including interference that may cause undesired operation of the device.

L'opération est soumise aux deux conditions suivantes: (1) cet appareil ne peut causer d'interférences, et (2) cet appareil doit accepter toute interférence, y compris celles susceptibles de provoquer fonctionnement du dispositif.

To reduce potential radio interference to other users, the antenna type and its gain should be so chosen that the equivalent isotropically radiated power (e.i.r.p.) is not more than that permitted for successful communication.

Afin de réduire les interférences radio potentielles pour les autres utilisateurs, le type d'antenne et son gain doivent être choisis de façon que la puissance isotrope rayonnée équivalente (PIRE) est pas plus que celle prévue pour une communication réussie.

RF exposure warning: The equipment complies with RF exposure limits set forth for an uncontrolled environment. The antenna(s) used for this transmitter must not be co-located or operating in conjunction with any other antenna or transmitter.

Avertissement d'exposition RF: L'équipement est conforme aux limites d'exposition aux RF établies pour un incontrôlé environnement. L'antenne (s) utilisée pour ce transmetteur ne doit pas être co-localisée ou fonctionner en conjonction avec toute autre antenne ou transmetteur.