

USER MANUAL

RFID Reader/Writer [74E-300810-0001-1D]

USER MANUAL

RFID Reader/Writer
74E-300810-0001-1D
(Built-in Type)



Version 1.05

USER MANUAL

RFID Reader/Writer [74E-300810-0001-1D]

Contents

1. Safety Precautions

1.1 Warning

1.2 Caution

2. Outline

2.1 Outline

2.2 Feature

2.3 In use

3. Architecture

3.1 System Architecture

4. Specification

4.1 Specification

4.2 Dimension

5. Names and Functions

5.1 Names and Functions of each part

6. Installation

6.1 Installation Environment

6.2 Connecting Cable

7. Communications Specifications

7.1 Communications Specifications

USER MANUAL

RFID Reader/Writer [74E-300810-0001-1D]

1. Safety Concerns

1.1 Warning



WARNING

1) In case installing this product, Turn off the power supply or remove the connection of power cable.

2) This product is permitted by Radio regulation law in Japan. So it is not necessary to get the permission of high frequency equipment to set. And this product doesn't use except for the following country.

<Built-in module>

R/W module model	Number
PC-180001-M	AC-10008

<Electric wave acquisition country>

Country	ID
China	
Maxico	
Spain	
Philippin	
Thailand	

If you use the module other than PC-180001 or remodels it, you are punished by ordinance.

Changes or modifications not expressly approved by the manufacturer for compliance could void the user's authority to operate the equipment. It is punished similarly when using it in a country other than the above.

3) Don't use other AC adaptor excluding our company specified. It might cause the electric shock, a fire, and the breakdown.

4) This product uses electric wave. According to the place and method for use, it is danger that influences medical equipment. Observe the following strictly when operating it to reduce this influence.

- ① Do not use this product in the hospital or the airport.
- ② Do not use it for medical equipment.
- ③ Those who install the planting type medical equipment must not bring the installation part close from the antenna of the RFID equipment within 22cm.

USER MANUAL

RFID Reader/Writer [74E-300810-0001-1D]

1.2 Caution



CAUTION

- 1) Please avoid the installation in the following places.
 - ① Environment that deviated from the specifications range of this product.
 - ② Use in the following place
 - a. Locations exposed to direct sunlight.
 - b. Locations high temperature and high humidity.
 - c. Locations directly subjected to vibration and shock.
 - d. Locations where a strong magnetic field or electric field occurs.
 - e. Locations with corrosive gas or inflammable gas.
 - f. Locations where condensation occurs due to sudden temperature changes.
 - g. Locations covered metal.
- 2) Content with danger of not operating normally
 - ① When there is equipment which generates the electric wave in the vicinity of 13.56MHz to be near.
 - ② When there are a speaker or an echo thing to be near.
 - ③ When in surroundings, there is a noise source.
- 3) Do not set up this product in an unstable place.
It causes the breakdown when falling .
- 4) If you don't use equipment for a long time, stop to supply power, except for pull out the AC adaptor.
- 5) This product is a communication device that uses the electric wave of 13.56MHz. This device complies with Part 15 of the FCC Rules.
Operation is subject to the following two conditions:
 - ① This device may not cause harmful interference, and
 - ② This device must accept any interference received, including interference that may cause undesired operation.
- 6) This product and the internal antenna must not be co-located or operating in conjunction with any other antenna or transmitter.
End user cannot modify this transmitter device.
Any unauthorized modification made on the device could avoid the user's authority to operate this device.
- 7) The distance of Reader/Writer (R/W) and IC tag changes by the following.
 - ① Holding of IC tag
 - ② Material (set up)
 - ③ Size and shape
 - ④ Presence of electric conducting material

USER MANUAL

RFID Reader/Writer [74E-300810-0001-1D]

2. Outline

2.1 Outline

This product is RFID Reader/Writer to be able to read and write IC tag data by non-contact by using the frequency of 13.56MHz. It is possible to use it for various usages of management of entrance and exit and the distribution management, etc.

A basic control of this product becomes operation of returning the response for the command from a upper system.

2.2 Feature

Even when two or more IC tag exists in the area which can be read, this product can be read.

It corresponds to a standard command and two or more option commands in accordance with international standard ISO/IEC15693.

Because the data of IC tag can be freely overwritten, it can repeat, and be low-cost.

It is a Reader/Writer of the small size and low power consumption.

As for the connection with a upper system, the connection with RS-232C or USB becomes possible.

Connector No.	Connector	Communication	Connecting Cable Specification
CN1	RS-232C	Transmission/Reception	D-sub 9pin↔RJ45
CN2	RS-232C	Transmission	D-sub 9pi↔RJ45
CN3	USB	Transmission/Reception	Series A Plug↔Series B Plug

2.3 In use

Because this product corresponds to "Inducement type reading and writing communication equipment" of "High frequency use equipment" of the Radio Law of Japan; This is applied to the Ministry of General Affairs, and the formal licensing is acquired.

Therefore, the user can use it without following a procedure for the permission application of the high frequency use equipment.

USER MANUAL

RFID Reader/Writer [74E-300810-0001-1D]

3. Architecture

3.1 System Architecture

This product communicates with the lower system (IC tag) and the upper system (computer and PLC, etc.).

This product can change operation by sending the command from the upper system.

Power is supplied by Reader/Writer's electric wave when IC tag enters the antenna area, and the Reader/Writer is communicated.

The communication with the upper system passes serial I/F or USB I/F.

Connection with Computer

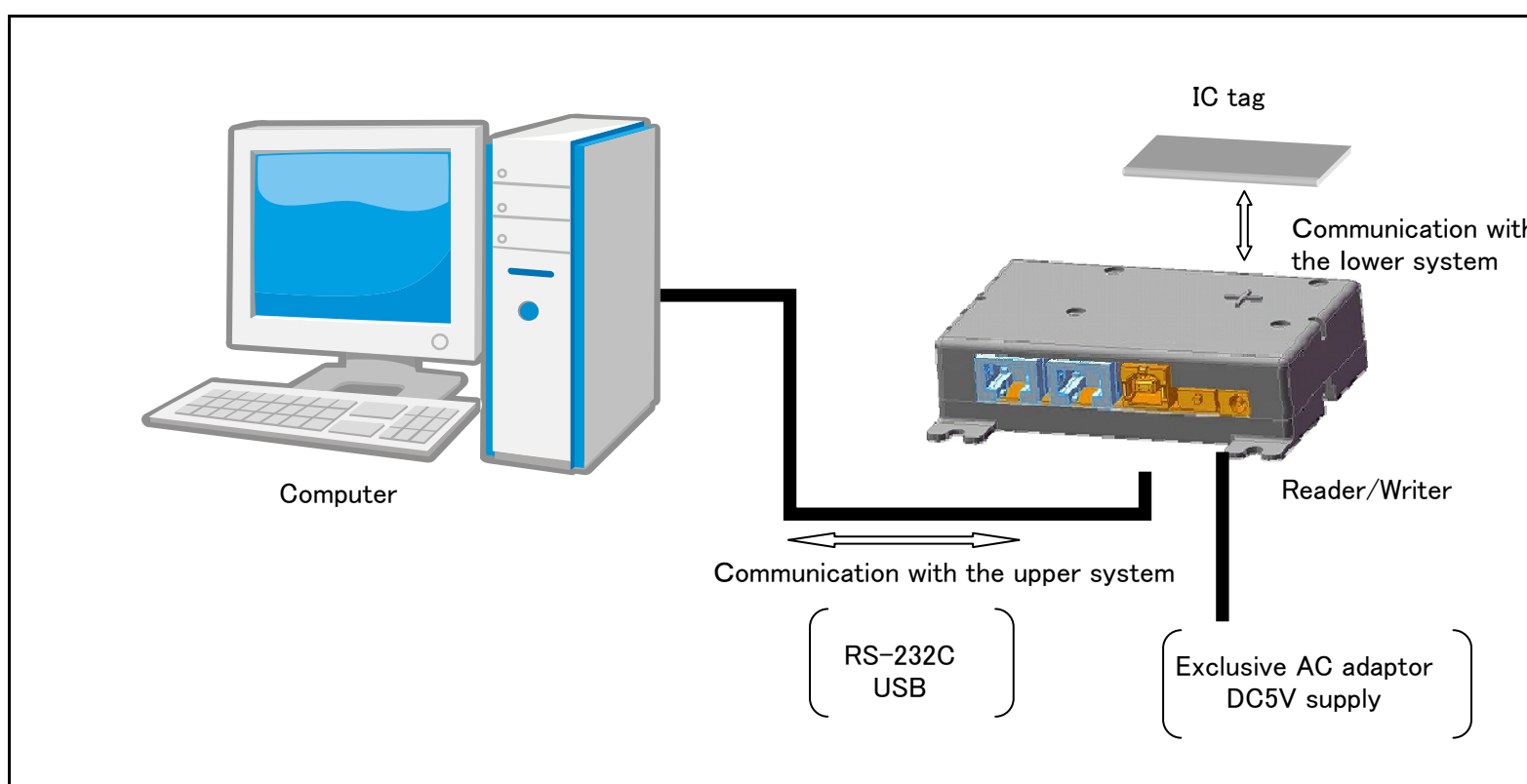

Connection with PLC

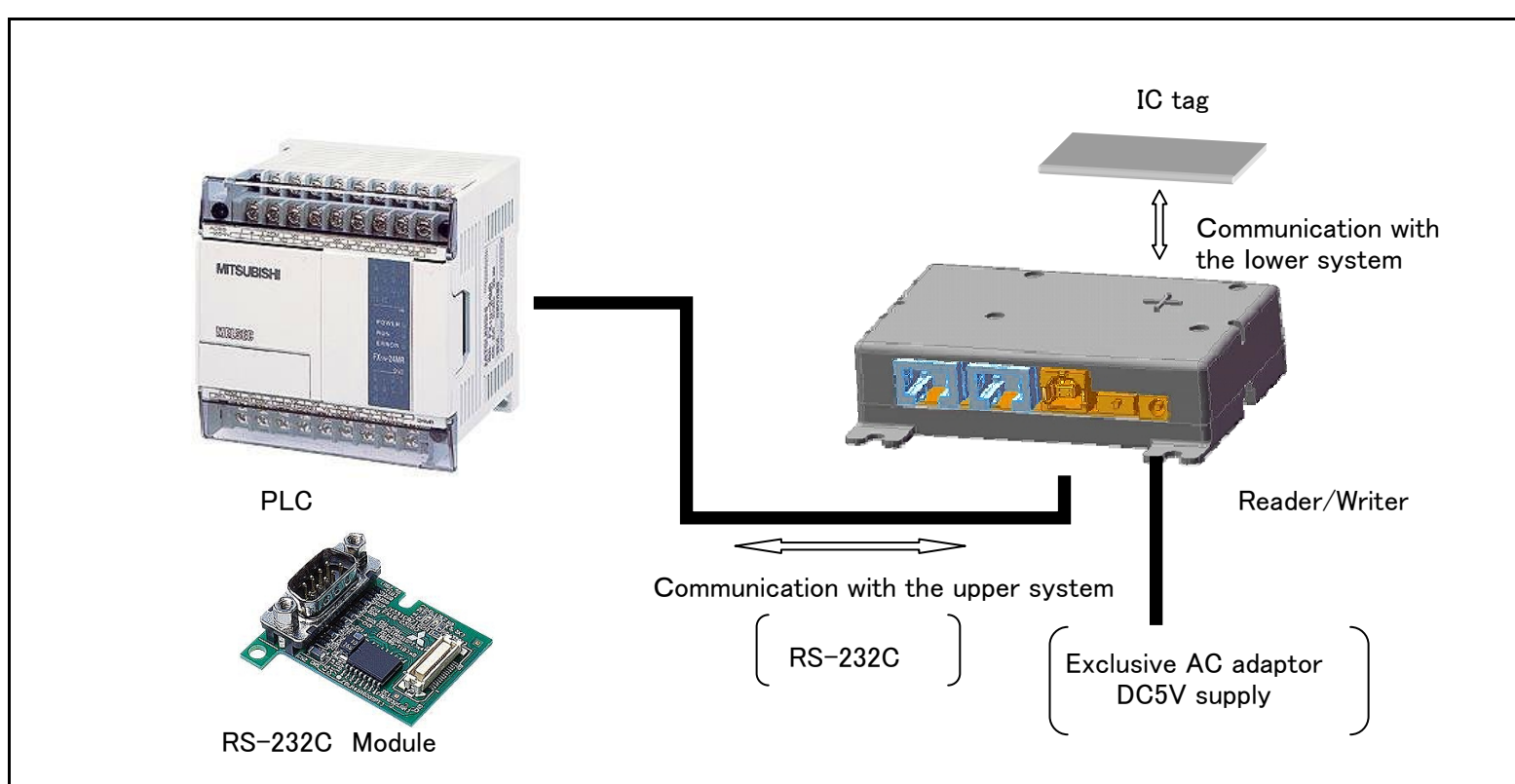

USER MANUAL

RFID Reader/Writer [74E-300810-0001-1D]

4.Specification

4.1 Specification

This product is RFID Reader/Writer to be able to read and write IC tag data by non-contact by using the frequency of 13.56MHz. It is possible to use it for various usages of management of entrance and exit and the distribution management, etc.

A basic control of this product is operation of returning the response to the command from the upper system.

Item	Specifications
Reader/Writer Module	PC-1080001-M (Japan Formal Licensing No.: AC-10008)
frequency	13.56 MHz \pm 7kHz
Applied tag (*1)	ISO15693 (Tag-it Plus/Pro, I-CODE SLI) ISO14443 (MIFARE Classic, MIFARE Ultralight) Felica (ID read only)
Communication Range (*2)	Tag-it : 80mm (Max.) MIFARE : 40mm (Max.) Felica : 35mm (Max.)
Communication Command	Multi Protocol Reader Writer Module (PC-1080001) (Refer to Software Specification)
I/F	Serial Communication Baud Rate: 19200bps (+ 0.32%) Transmission Method: Asynchronous Communication Method Data Structure: Data Length: 8bit, Stop Bit: 1bit, Non Parity Error Detecting: BCC Method Response Method: Response
Working Temperature	0°C - 60°C
Working Humidity	30% - 85%R.H. (Non condensing)
Rated Power	DC 5V 10VA
Dimensions	60 mm X 95 mm X 25 mm (Exclude the installation flange)

- *1) "Tag-it HF-I" is a registered trademark of the TEXAS INSTRUMENTS Inc.
"I.CODE SLI" and "MIFARE" are registered trademarks of the NXP Semiconductors Ltd.
"Felica" is a registered trademark of the Sony Corporation.
"Felica" is a technological method of the contactless IC card which the Sony Corporation developed.
- *2) It is a value for opposing the card tag and the antenna correctly.
The value is different depending on the system requirements and the tag type.
Please see "Multi protocol R/W module software specifications" about the specification of software.

4.2 Dimension

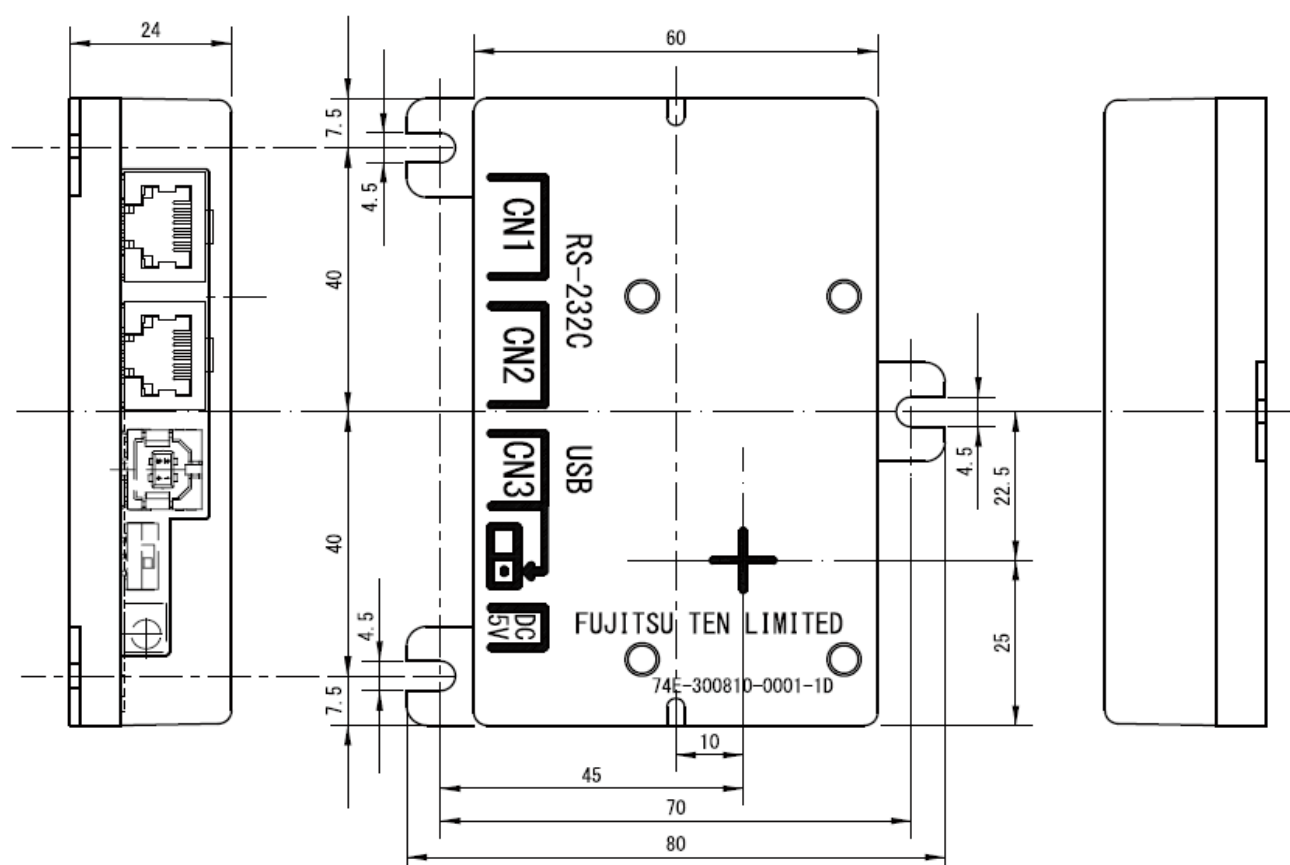

USER MANUAL

RFID Reader/Writer [74E-300810-0001-1D]

5. Names and Functions

5.1 Names and Functions of each part

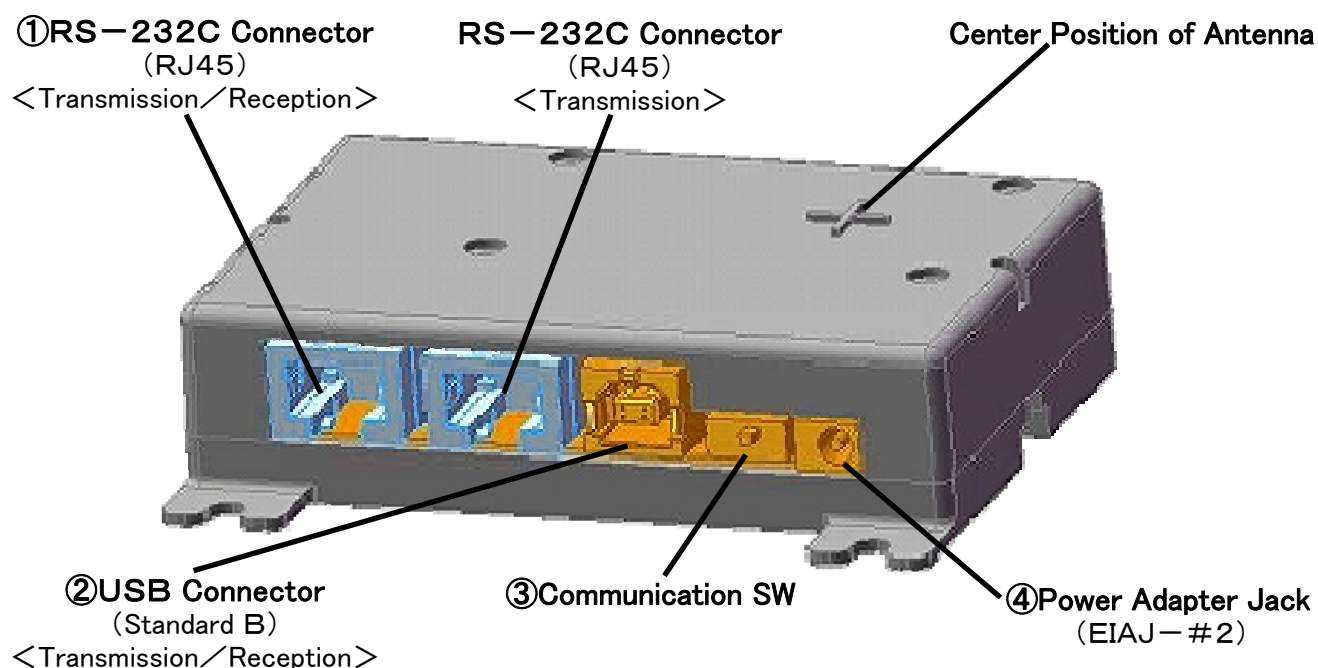

①RS-232C Connector

It is a connector of a Reader/Writer and the PC. The communication protocol is RS-232C. (flow control is not done)
In case connect to the PC, use the crossing cable of D-sub 9P (female) connector and RJ45 connector.
Turn on the left of ③Communication SW

Cable (Recommended) : CBL-RJ45F9-150 (MOXA)

Show the signal name the table below.

RS-232C(D sub connector 9P)

Pin No.	Abbreviation	Name
1	DCD	Data Carrier Detect
2	TxD	Transmitted Data
3	RxD	Received Data
4	DSR	Data Set Ready
5	GND	GND
6	DTR	Data Terminal Ready
7	CTS	Clear to Send
8	RTS	Request to Send
9	---	

RS-232C(RJ45 connector)

Pin No.	Abbreviation	Name
1	DSR	Data Set Ready
2	RTS	Request to Send
3	GND	GND
4	TxD	Transmitted Data
5	RxD	Received Data
6	DCD	Data Carrier Detect
7	CTS	Clear to Send
8	DTR	Data Terminal Ready

②USB Connector

It is a connector of a Reader/Writer and the PC.
In case connect to the PC, use the USB cable.
Turn on the right of ③Communication SW

Show the signal name the table below.

USB connector (Standard B)

Pin No.	Name	Function
1	Vbus	+5V
2	-Data(D-)	Data Line
3	+Data(D+)	Data Line
4	GND	GND

④Power Adapter Jack

It is an input terminal; DC5V.

Exclusive AC Adapter : US30-0520 <correspondence CE marking> [UNIFIVE CO.,LTD.]

Rated Power : AC100V-AC240V(50/60Hz) 12W, 0~50°C

Voltage(OUT):+5V、Current(OUT):2A、Plug specification :EIAJ Voltage division2



WARNING

Do not use exclusive AC adapter.

USER MANUAL

RFID Reader/Writer [74E-300810-0001-1D]

6. Installation

6.1 Installation Environment

6.1.1 General

Please avoid the installation in the following places.



CAUTION

- Environment that deviated from the specifications range of this product.
- Direct sunlight
- High temperature and high humidity
- Vibration
- Strong magnetic force and shock voltage
- Firedamp
- Condensation or temperature excursion
- An electrically charged thing



WARNING

- Do not use in the hospital or the airport.
- Do not use it for medical equipment.
- Those who install the planting type medical equipment must not bring the installation part close from the antenna of the RFID equipment within 23cm.

6.1.2 Environment in facilities



CAUTION

- Set up at the good ventilation.
- Don't set up near high temperature equipment (Heater,Transfer,Resistance(large capacity))
- In case temperature is over 60°C, set up the fan or air conditioner to down the temperature.
- Don't wire near the power code.

This product use the frequency of 13.56MHz, please attend to the following.

- Metal
Metal has the characteristic, reflect the electric wave.
Reception of the equipment becomes worse or there is a possibility of detecting it in the area where the IC tag is not detected either.
- Noise
Transceiver, motor, monitor and power source, generate the noise that influences the communication with IC tag.
So in case using near the these equipment check the influence before use.

6.1.3 Installation method

Tighten an M4 screw with spring washer and flat washer in three places.
Do not use the hexagon head screw, so as not to tighten too much.
(The tighten torque is 0.75 ± 0.05 N·m is recommended.)

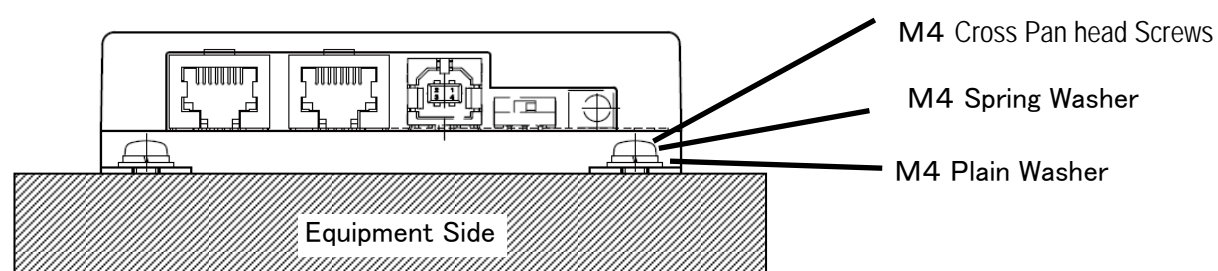

USER MANUAL

RFID Reader/Writer [74E-300810-0001-1D]

6. Installation

6.2 Connecting Cable



CAUTION

- Set up the cable away from the equipment putting out noise.
- After it wires, check the connector is firmly set or not.
- Attend to cause the large power to the connector
- Install the ferrite core in each cable for the noise control.

6.2.1 Location of Installing Ferrite Core

Power Cable: Set up the ferrite core in two places within 100mm from the main body of the power adaptor, and within 100mm from the Reader/Writer's main body.

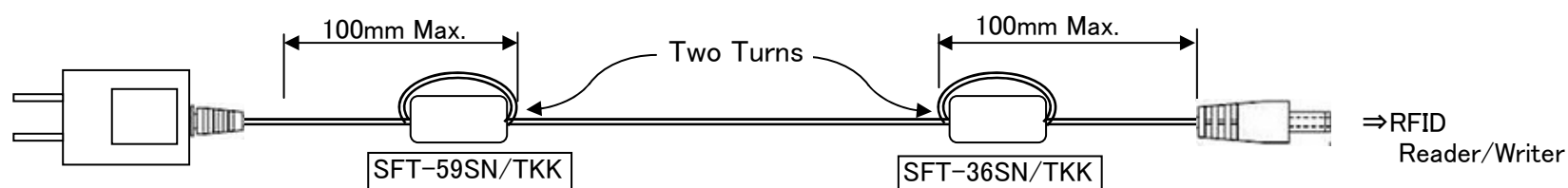

Communication Cable (RS-232C, USB): Set up the ferrite core within 100mm from the the Reader/Writer's main body.

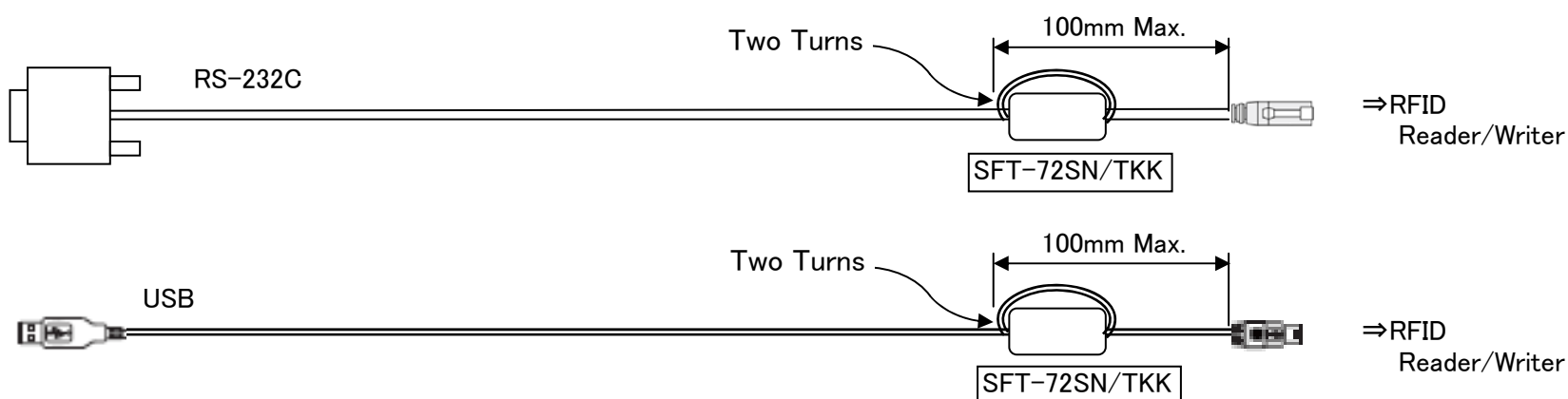

6.2.2 Method of Installing Ferrite Core

The cable around the ferrite core once so that the ferrite core should not move.
Close the ferrite core until you hear it click into place.

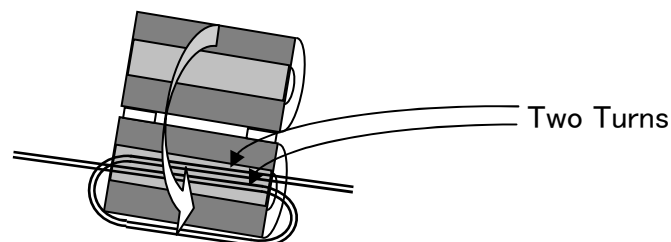

7. Communications Specifications

7.1 Communications Specifications

This Reader/Writer has the serial interface (RS-232C)(USB)

RS-232C interface (CN1)

PC can control a Reader/Writer by using serial interface

Serial Communication Format	
Bit Rates	19200 bps
Data Transmission	8 bit
Stop Bit	1 bit
Parity	-

USB interface (CN3)

PC can control a Reader/Writer by using serial interface

Serial Communication Format	
Bit Rates	19200 bps
Data Transmission	8 bit
Stop Bit	1 bit
Parity	-