



- **BOLERO-LT**

- **GSM/GPRS/GPS DEVICE**

- **HARDWARE DESCRIPTION**

- **PRELIMINARY**



**TABLE OF CONTENTS**

**1 INTRODUCTION .....6**

    1.1 GENERAL .....6

    1.2 CIRCUIT CONCEPT .....8

    1.3 USED ABBREVIATIONS .....9

    1.4 RELATED DOCUMENTS .....10

**2 SECURITY .....11**

    2.1 GENERAL INFORMATION .....11

    2.2 EXPOSURE TO RF ENERGY .....11

    2.3 EFFICIENT MODEM OPERATION .....12

    2.4 DRIVING .....12

    2.5 ELECTRONIC DEVICES .....12

    2.6 VEHICLE ELECTRONIC EQUIPMENT .....12

    2.7 MEDICAL ELECTRONIC EQUIPMENT .....12

    2.8 AIRCRAFT .....12

    2.9 CHILDREN .....13

    2.10 BLASTING AREAS .....13

    2.11 POTENTIALLY EXPLOSIVE ATMOSPHERES .....13

    2.12 NON-IONIZING RADIATION .....13

**3 SAFETY STANDARDS .....14**

**4 TECHNICAL DATA .....15**

    4.1 GENERAL SPECIFICATIONS OF TERMINAL BOLERO-LT .....15

        4.1.1 Power consumption .....16

        4.1.2 Operating temperatures .....16

    4.2 TECHNICAL SPECIFICATIONS OF GSM/GPRS ENGINE .....17

    4.3 TECHNICAL SPECIFICATIONS OF GPS RECEIVER .....18

    4.4 NMEA DATA MESSAGE .....19

**5 BOLERO-LT APPLICATION INTERFACE .....20**

    5.1 POWER SUPPLY .....20

        5.1.1 Power supply pins (3 and 4) on the 6-pin connector .....20

        5.1.2 Automatic shutdown .....20

    5.2 DETERMINING THE EXTERNAL EQUIPMENT TYPE .....20

**6 HARDWARE INTERFACES .....21**

    6.1 6-PIN CONNECTOR .....21

        6.1.1 Pin assignment on the 6-pin connector .....21

        6.1.2 Special pin description .....22

            6.1.2.1 Analog input (6) .....22

                6.1.2.1.1 Connection example using IO1 as analog inputs: .....22

                6.1.2.2 Digital Input (pin 6) .....23

                6.1.2.3 Output (pin 6) .....24

                6.1.2.4 How to use IGN pin ((pin 5) .....25

6.1.3 Buttons & LEDs .....26

6.1.4 SIM card interface .....27

6.1.5 Special pin description .....27

    6.1.5.1 Serial communication signals (RxA, TxA ) .....27

**6.2 MOUNTING THE BOLERO-LT DEVICE .....28**

**7 RF EXPOSURES .....29**

**8 APPENDIX .....30**

**8.1 SCHEMATICS .....30**

        8.1.1 Installation guidance for 6-pin connector .....30

**VERSION HISTORY:**

Version	Author	Changes	Changed date
1.0.0	F. Beqiri	- Initial release	04/12/2007

## CAUTIONS

Information furnished herein by FALCOM is accurate and reliable. However, no responsibility is assumed for its use.

Please, read carefully the safety precautions.

If you have any technical questions regarding this document or the product described in it, please contact your vendor.

General information about FALCOM and its range of products are available at the following Internet address: <http://www.falcom.de/>

## TRADEMARKS

Some mentioned products are registered trademarks of their respective companies.

## Copyright

This documentation is copyrighted by **FALCOM WIRELESS COMMUNICATIONS GmbH** with all rights reserved. No part of this documentation may be produced in any form without the prior written permission of **FALCOM WIRELESS COMMUNICATIONS GmbH**.

## FALCOM WIRELESS COMMUNICATIONS GMBH.

No patent liability is assumed with respect to the use of the information contained herein.

# 1 INTRODUCTION

This product manual is only addressed to qualified personnel which is well skilled in electronical/electrical installation and not addressed to private consumers/end users. The installation, implementing or setting into operation of the product can only be performed by this qualified personnel.

*The status of the product described in the data sheet may have changed since publication of the data sheet and therefore information in this data sheet on product status may be outdated. The latest information of the product is published on the download area of the FALCOM website.*

## 1.1 General

This description is focused on the GSM/GPRS and GPS terminal BOLERO-LT from FALCOM GmbH. It contains a variety of information about hardware concepts and issues of the BOLERO-LT device.

*In order quickly to start and immediately and comprehensive to use all functions and to avoid any mistakes of BOLERO-LT device on your utilization, we recommend to read the following references and suggestions for using your new BOLERO-LT device.*

BOLERO-LT consists of a Quad-band GSM/GPRS engine that works on the four frequencies GSM 850/900/1800/1900 MHz, a 20 channel GPS receiver based on SiRFstarIII engine and an embedded configurable software that provides location-based applications. The new device can be easily integrated into a variety of new applications stretching from real-time navigation and positioning to remote tracking and monitoring. It is designed for indoor use and ideal for fixed installation. The device concept is targeting for direct implementation as a mobile client in a wide range of high volume, low-cost, flexible system solutions like *AVL, fleet management, vehicle security and recovery and other related area*. The tracking functionality of the embedded mobile client application is combined with variety of alert messaging capabilities. The configurable alert messages contain current position and status report. It uses 1 digital input for monitoring the ignition key of your vehicle as well as 1 line for use either as input or output. Depending on how the system BOLERO-LT is set up, the I/O line can be supplied as digital output allowing remote control of external actuators. In addition to that two predefined digital inputs are detecting ignition line and main power (car battery) failure, and so you may handle these events and use as notification.

*By default, BOLERO-LT is offered without internal battery. Shall you need a BOLERO-LT device with an internal battery, please see "**Ordering Guide**" and choose one that meets your specific requirements. The housing of the new BOLERO-LT device offers IP65 protection (with protection rubber) and can be operated at ambient temperatures up to +85°C.*

The embedded software the embedded software can be controlled by word like "**PFAL**" commands needed for executing particular actions, reading or setting particular configurations into the device. These commands are valid for all kinds of operations including **SMS, CSD, TCP and SMTP**.

BOLERO-LT provides Geofence features for territory management, route verification, prohibited locations, parking area and more with exception reporting to a wide variety of events, such as arrivals, departures, deliveries, pick-ups, illegal

entries, unauthorized movement, etc. BOLERO-LT contains a data-logger that enables it to archive unique locations in sequence for up to 45 days for later analysis and evaluation (for example, archive interval up to 20 sec.).

The physical interface to the terminal application is made through a 6-pin connector. It provides a serial interface giving you maximum flexibility for local use such as controlling the terminal, receiving GPS location data, transferring data.

Figure 1 shows the front and top side of the BOLERO-LT covered with a protection rubber.



**Figure 1:** BOLERO-LT covered with a protection rubber

BOLERO-LT terminal can be implemented into any asset platform, including:

- Trailers
- Trucks
- Delivery vans
- Rail cars
- as well as other industrial monitoring installations.

and it can be used in a variety of applications, including:

- Real time online tracking
- Fleet management / monitoring
- Security / emergency services
- Real time satellite navigation
- Territory management
- Personalized drivers logbook
- Route verification
- Trip management / distance calculations
- Theft protection
- Toll collection / pay as you drive

BOLERO-LT - EVALKIT provides an easy and efficient way to evaluate and configure all system parameters of the mobile client. The configuration of the BOLERO-LT can be done locally via serial link or remotely via the GSM/GPRS network. The BOLERO-LT concept reduces the efforts for the creation of a turn key tracking and security solution to the definition of the server (dispatcher) application. In this way the time-to-market, the design-in risk and the total cost of solution are substantially reduced.

## 1.2 Circuit concept

The BOLERO-LT architecture includes the following major functional components (see figure 2):

❖ **ARCHITECTURE INTEGRATES:**

- High-performance Quad-Band GSM/GPRS core (operating at 26MHz),
- 20 parallel channel low-power GPS core (operating at L1 1575.42 MHz and C/A code 1,023 MHz chip rate),
- ARM7TDMI Processor (at speed 25MHz) that controls all functions of the system,
- Internal SIM card reader (1.8V and 3V),
- Internal GSM antenna,
- Internal GPS antenna,

❖ **Options to BOLERO-LT**

- 3D motion sensor
- Rechargeable Li-Polymer battery (see *Ordering Guide*),
- Audio for voice call

❖ **Physical interfaces:**

- Power supply line,
- 1x Multi-line I/O,
- 1 x Ignition;
- RS232 port
- SIM Card reader (Type: Molex-91228-0002 small SIM Card)
- LED status indicators.

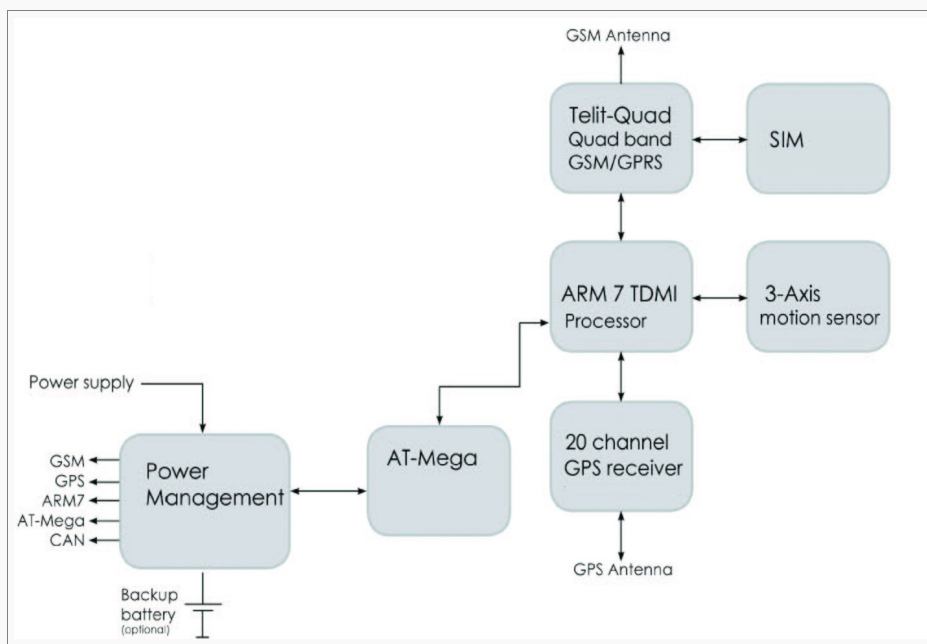

Figure 2: Architecture of the BOLERO-LT terminal



### 1.3 Used abbreviations

Abbreviation	Description
ASIC	Application Specific Integrated Circuit
DOP	Dilution of Precision
GPS	Global Positioning System
GSM	Global Standard for Mobile Communications
GGA	GPS Fixed Data
HDOP	Horizontal DOP
HW	Hardware
IMEI	International Mobile Equipment Identity
I/O	Input/Output
NMEA	National Marine Electronics Association
PRN	Pseudorandom Noise Number – The Identity of GPS satellites
RF	Radio Frequency
RTC	Real Time Clock
RXQUAL	Received Signal Quality
SIM	Subscriber Identification Module
SMS	Short Message Service
SRAM	Static Random Access Memory
TA	Terminal Adapter
TE	Terminal Equipment
TP	Transmit Protocol
TTFF	Time to First Fix
SA	Selective Availability
WAAS	Wide Area Augmentation System
MSK	Minimum Shift Keying

**Table 1:** Used abbreviations

## 1.4 Related documents

Some others PDF documents such as FCC approval, application notes, Certificate of Conformity R&TTE etc. are also available on the Web at: <http://www.falcom.de/> in the published download area.

In addition to this document, the following files comprise the full set of FALCOM BOLERO-LT product manuals:

NR	PDF file name	Description
[1]	steppIII_fox_bolero_lt_PFAL_Configuration_Command_Set.pdf	Contains the description of the internal firmware and the supported Configuration Command Set for the FALCOM STEPPIII, FOX and BOLERO-LT.
[2]	AppNotes_Transform_history_data.pdf	Contains information of how to transform history data that are being transmitted from BOLERO-LT via TCP connection.
[3]	AppNote_Remote_update.pdf	Contains information of how to upgrade FALCOM AVL devices device to a new firmware revision remotely via TCP.
[4]	AppNotes_in_vehicle_mounting.pdf	This document provides all the necessary information to allow your FALCOM product to be properly and safely installed.

*These PDF files are viewable and printable from Adobe Reader. If you do not have the Adobe Reader installed, you can download it from <http://www.adobe.com>.*

## 2 SECURITY

### **IMPORTANT FOR THE EFFICIENT AND SAFE OPERATION OF YOUR GSM-MODEM, READ THIS INFORMATION BEFORE USE!**

Your cellular engine BOLERO-LT is one of the most exciting and innovative electronic products ever developed. With it you can stay in contact with your office, your home, emergency services and others, wherever service is provided.

This chapter contains important information for the safe and reliable use of the BOLERO-LT. Please read this chapter carefully before starting to use the cellular engine BOLERO-LT.

### 2.1 General information

Your BOLERO-LT device utilizes the GSM/GPRS/GPS standard for cellular technology. GSM/GPRS is a newer radio frequency („RF“) technology than the current FM technology that has been used for radio communications for decades. The GSM standard has been established for use in the European community and elsewhere. Your modem is actually a low power radio transmitter and receiver. It sends out and receives radio frequency energy. When you use your modem, the cellular system handling your calls controls both the radio frequency and the power level of your cellular modem.

*For the use of the acquired devices SIM cards are needed, which are not included in the scope of delivery of the device. The SIM cards can be acquired e.g. by specific providers. From the use of the SIM cards can result additional costs, which are to be borne by the purchaser (client) of the devices. The seller does not cover the extra costs for the use of the devices. The seller gives no recommendation for the use of specific SIM cards and does not liable also for the fact that the devices are usable with all available SIM cards. The seller also covers no other costs, that are needed for the application of the customer in connection with this device.*

### 2.2 Exposure to RF energy

There has been some public concern about possible health effects of using a GSM modem. Although research on health effects from RF energy has focused for many years on the current RF technology, scientists have begun research regarding newer radio technologies, such as GSM. After existing research had been reviewed, and after compliance to all applicable safety standards had been tested, it has been concluded that the product is fit for use.

If you are concerned about exposure to RF energy there are things you can do to minimize exposure. Obviously, limiting the duration of your calls will reduce your exposure to RF energy. In addition, you can reduce RF exposure by operating your cellular modem efficiently by following the guidelines below.

## 2.3 Efficient modem operation

In order to operate your modem at the lowest power level, consistent with satisfactory call quality please take note of the following hints.

If your modem has an extendible antenna, extend it fully. Some models allow you to place a call with the antenna retracted. However, your modem operates more efficiently with the antenna fully extended.

Do not hold the antenna when the modem is „IN USE“. Holding the antenna affects call quality and may cause the modem to operate at a higher power level than needed.

## 2.4 Driving

Check the laws and regulations on the use of cellular devices in the area where you drive. Always obey them. Also, when using your modem while driving, please pay full attention to driving, pull off the road and park before making or answering a call if driving conditions so require. When applications are prepared for mobile use they should fulfil road-safety instructions of the current law!

## 2.5 Electronic devices

Most electronic equipment, for example in hospitals and motor vehicles is shielded from RF energy. However, RF energy may affect some malfunctioning or improperly shielded electronic equipment.

## 2.6 Vehicle electronic equipment

Check your vehicle manufacturer's representative to determine if any on board electronic equipment is adequately shielded from RF energy.

## 2.7 Medical electronic equipment

Consult the manufacturer of any personal medical devices (such as pacemakers, hearing aids, etc.) to determine if they are adequately shielded from external RF energy.

Turn your BOLERO-LT device OFF in health care facilities when any regulations posted in the area instruct you to do so. Hospitals or health care facilities may be using RF monitoring equipment.

## 2.8 Aircraft

Turn your BOLERO-LT OFF before boarding any aircraft.

Use it on the ground only with crew permission.

Do not use it in the air.

To prevent possible interference with aircraft systems, Federal Aviation Administration (FAA) regulations require you to have permission from a crew member to use your modem while the plane is on the ground. To prevent

interference with cellular systems, local RF regulations prohibit using your modem whilst airborne.

## 2.9 Children

Do not allow children to play with your BOLERO-LT device. It is not a toy. Children could hurt themselves or others (by poking themselves or others in the eye with the antenna, for example). Children could damage the modem or make calls that increase your modem bills.

## 2.10 Blasting areas

To avoid interfering with blasting operations, turn your unit OFF when in a "blasting area" or in areas posted: „turn off two-way radio“. Construction crew often use remote control RF devices to set off explosives.

## 2.11 Potentially explosive atmospheres

Turn your BOLERO-LT device **OFF** when in any area with a potentially explosive atmosphere. It is rare, but your modem or its accessories could generate sparks. Sparks in such areas could cause an explosion or fire resulting in bodily injury or even death.

Areas with a potentially explosive atmosphere are often, but not always, clearly marked. They include fuelling areas such as petrol stations; below decks on boats; fuel or chemical transfer or storage facilities; and areas where the air contains chemicals or particles, such as grain, dust or metal powders.

Do not transport or store flammable gas, liquid or explosives, in the compartment of your vehicle, which contains your modem or accessories.

Before using your modem in a vehicle powered by liquefied petroleum gas (such as propane or butane) ensure that the vehicle complies with the relevant fire and safety regulations of the country in which the vehicle is to be used.

## 2.12 Non-ionizing radiation

As with other mobile radio transmitting equipment users are advised that for satisfactory operation and for the safety of personnel, it is recommended that no part of the human body is allowed to come too close to the antenna during operation of the equipment. The radio equipment shall be connected to the antenna via a non-radiating 50 Ohm coaxial cable. The antenna shall be mounted in such a position that no part of the human body will normally rest close to any part of the antenna. It is also recommended to use the equipment not close to medical devices as for example hearing aids and pacemakers.

### 3 SAFETY STANDARDS

This GSM/GPS modem complies with all applicable RF safety standards.

The embedded GSM/GPRS/GPS modem meets the safety standards for RF receivers and the standards and recommendations for the protection of public exposure to RF electromagnetic energy established by government bodies and professional organizations, such as directives of the European Community, Directorate General V in matters of radio frequency electromagnetic energy.

## 4 TECHNICAL DATA

### 4.1 General specifications of terminal BOLERO-LT

#### ↪ Supply voltage range:

- Operating power supply voltage range of +10.8 V to +35.0V, suitable for direct connection to an automotive +12V or +24V DC power source (car battery).

#### ↪ Power saving :

- 8 different energy-saving modes - programmable with PFAL commands.
- Sleep modes minimize power consumption.

#### ↪ Operating temperature range:

- -40 °C to + 85 °C (see chapter 4.1.2 for further details)

#### ↪ Physical characteristics :

- Size: 85 mm x 56 mm x 20 mm (W x L x H)
- Weight: ca. 90 g
- Cable length: 1 m

#### ↪ Physical Interfaces :

- Six-wire cable with an 6-pin connector on the end:
  - ✓ 1 x I/O (firmware-controlled as **digital input/output** or **analog** inputs, by default it is an input)
  - ✓ 1 x Ignition (with software - controlled feature),
  - ✓ 1 x Power supply (with software - controlled feature)
  - ✓ 1 x Serial port (Rx, Tx), Baud rate is controlled by firmware (by default 57600 bps), 8 data bits, no parity, 1 stop bit, no flow control,
- SIM Card interface (for **1.8 V** and **3 V** SIM cards)
- **3 X LED** indicators (free-programmable by the software)

#### ↪ Hardware options :

- **3D motion** sensor (Compact motion sensor for measuring motion in 3 axes)
- **Audio** interface for voice call (1 x Microphone; 1 x Speaker)
- Rechargeable Li-Polymer battery (see [Ordering Guide](#)),
- Degree of protection (the housing of the BOLERO-LT offers **IP65 protection** from dust and jets of water.)

#### ↩ **Casing :**

- Fully shielded

#### ↩ **Certifications :**

- Fully type approved confirming with R&TTE directive.
- CE, FCC, PTCRB, e1,IC.

#### ↩ **Directive :**

- RoHS compliant.

#### ↩ **Firmware :**

- Embedded TCP/IP stack (inc. TCP, IP and SMTP protocol),
- Accessible via PFAL commands,
- Upgradeable via serial port and remotely over the air (GPRS/TCP interface).

#### ↩ **Memory :**

- 2 Mbyte FLASH for configuration, data-logging and firmware storage

#### ↩ **Serial ports :**

- 1 x full duplex serial communication

#### ↩ **Serial Interface Setting :**

- Full duplex serial communication, CMOS level
- 2-wires (1 x Rx and 1 x Tx) for serial communication
- Baud rate on the serial port (user configuration).
- 8 data bits, no parity, 1 stop bit, no flow control.

#### ↩ **Evaluation kit :**

- The BOLERO-LT Evalkit is designed to test, evaluate and make basis configuration to enable remote monitoring/configuration of the FALCOM BOLERO-LT. It provides a sample configuration for application.

### 4.1.1 Power consumption

To be defined.

### 4.1.2 Operating temperatures

Parameter	Min.	Typ.	Max.	Unit
Storage temperature ( <i>without internal battery</i> )	-40	+25	+90	°C
Operating temperature ( <i>without internal battery</i> )	-40	+25	+85	°C
GSM* ( <i>without internal battery</i> )	-30	+25	+80	°C
Charging temperature ( <i>with internal battery enabled ***</i> )	0	+25	+45	°C
Discharging temperature ( <i>with internal battery enabled ***</i> )	-20	+25	+60	°C

\* The extreme temperature can affect the sensitivity and performance of the GSM engine.

\*\* Using configuration \$PFAL,Cnf.Set,DEVICE.BAT.MODE=**disabled**

\*\*\* Using configuration \$PFAL,Cnf.Set,DEVICE.BAT.MODE=**auto**

Table 2: Operating temperature



## 4.2 Technical specifications of GSM/GPRS engine

### ↩ Frequency bands:

- *Telit GE864-Quad module*
- *Quad-Band: **GSM 850, 900, DCS 1800, PCS 1900.***
- *Compliant to GSM Phase 2/2+*

### ↩ Transmit power:

- *Class 4 (2 W) at EGSM900 and GSM850*
- *Class 1 (1 W) at GSM1800 and GSM 1900*

### ↩ GPRS connectivity:

- *GPRS multi-slot class 10*
- *GPRS mobile station class B*

### ↩ DATA:

#### **GPRS** ⇒

- *GPRS data downlink transfer: max. 85.6 kbps see table 3).*
- *GPRS data uplink transfer: max. 42.8 kbp (see table 3).*
- *Coding scheme: CS-1, CS-2, CS-3 and CS-4.*

#### **CSD** ⇒

- *CSD transmission rates: 2.4, 4.8, 9.6, 14.4 kbps, non-transparent, V.110.*

### ↩ SMS:

- *Text mode*

### ↩ GSM Antenna:

- *internal.*

### ↩ Ringing tones:

- *Offers a choice of 32 different ringing tones/melodies, easily selectable with PFAL command.*

### ↩ GPRS Coding scheme:

Coding scheme	1 Timeslot	2 Timeslots	4 Timeslots
CS-1:	9.05 kbps	18.1 kbps	36.2 kbps
CS-2:	13.4 kbps	26.8 kbps	53.6 kbps
CS-3:	15.6 kbps	31.2 kbps	62.4 kbps
CS-4:	21.4 kbps	42.8 kbps	85.6 kbps

**Table 3:** Coding schemes and maximum net data rates over air interface

Please note that, the values listed above are the maximum ratings which, in practice, are influenced by a great variety of factors, primarily, for example, traffic variations and network coverage.

### 4.3 Technical specifications of GPS receiver

↳ **GPS features:**

- *JP13-S-LP FALCOM GPS product with SiRFstarIII chip set.*
- *High sensitive 20 channel, L1 1575.42 MHz, C/A code 1,023 MHz chip rate.*
- *SiRF GSW3*

↳ **Accuracy:**

- *Position accuracy: < 10 m CEP without SA*

↳ **Datum:**

- *WGS-84.*

↳ **Time to First Fix (TTFF):**

- *Hot start < 1 sec., average*
- *Cold start \* < 42 sec, average*

↳ **Sensitivity:**

- *Tracking -159 dBm*

↳ **Dynamic Conditions:**

- *Altitude 18,000 meters (60,000 feet) max.*
- *Velocity < 515 meters/second (1000 knots) max.*
- *Max. update rate 1 Hz*

↳ **Supported protocols:**

- *NMEA Msg.: **GLL, GGA, RMC, VTG, GSV, GSA***
- *FALCOM Msg.: **IOP, GSM, AREA, 3DP, BIN** - see ["NMEA data message" chapter 4.4.](#)*

↳ **Crystal oscillator (TCXO):**

- *Load sensitivity ± 10 % load change, 0.2 ± ppm*

↳ **GPS antenna**

- *internal.*

## 4.4 NMEA data message

The BOLERO-LT device delivers data in the NMEA-0183 format. *Table 4* below lists each of the NMEA output messages and FALCOM developed its own protocols supported by the BOLERO-LT terminal and a brief description. For further description about NMEA, see [Related documents\[4\]](#).

The running firmware offers the possibility to switch on or off each protocol listed below for local use. With the help of PFAL commands supported by this firmware these protocols can also be transferred via **SMS**, **TCP**, **Data** call and **E-mail**.

<b>NMEA</b>	<b>Description</b>
GGA	<i>Time, position and fix type data.</i>
GLL	<i>Latitude, longitude, UTC time of position fix and status.</i>
GSA	<i>GPS receiver operating mode, satellites used in the position solution and DOP values.</i>
VTG	<i>The number of GPS satellites in view satellite ID numbers, elevation, azimuth and SNR values.</i>
GSV	<i>The number of GPS satellites in view satellite ID numbers, elevation, azimuth and SNR values.</i>
RMC	<i>Time, date, position, course and speed data.</i>
<b>FALCOM</b>	<b>Description</b>
IOP	<i>The status of the digital/analog inputs and output ports and battery voltage (if battery available)</i>
GSM	<i>The GSM operator, reception, registration status, GSM field strength, area code and cell ID.</i>
AREA	<i>The state of 32 areas</i>
3DP	<i>The state of the motion Sensor (hardware option)</i>
BIN	<i>User protocol including time, date, position, course and speed data.</i>

**Table 4:** NMEA and FALCOM Output Messages

## 5 BOLERO-LT APPLICATION INTERFACE

### 5.1 Power supply

The power supply for the BOLERO-LT terminal has to be a single voltage source within the range  $V_{+IN} = +10.8 \text{ V} \dots +35.0 \text{ VDC}$ . It must be able to provide sufficient current. The operating voltage ( $V_{+IN}$  and GND) is protected from reverse pole connection and against voltage spikes, but not against over voltage.

**NOTE: Operating voltage range must never be exceeded; care must be taken in order to fulfill min/max voltage requirements.**

#### 5.1.1 Power supply pins (3 and 4) on the 6-pin connector

The +IN pin on the 6-pin connector is dedicated to connect the supply voltage, GND pin is for grounding. The +IN and GND pins serve for charging the internal battery (if available) and powering the BOLERO-LT device. The power supply for the BOLERO-LT is capable of utilizing current ranging from  $V_{+IN} = +10.8 \text{ V} \dots +35.0 \text{ VDC}$  designed for automotive application.

Signal name	I/O	Parameter	Description
+IN	I	+10.8 V...+35.0VDC. The operating voltage must never be exceeded.	Positive operating voltage. <i>For security reason, it is recommended to integrate externally a 2A fuse link between interconnection plug (6-pin connector) and d.c.-power source (see Fig 19).</i>
GND	-	0 V	Ground

#### 5.1.2 Automatic shutdown

Automatic shutdown takes effect if:

- *under voltage is detected when battery level (if available) runs low and no external power supply connected.*

The automatic shutdown procedure is equivalent to the power-down initiated, i.e. BOLERO-LT logs off from the network and the software enters a secure state avoiding loss of data.

## 5.2 Determining the External Equipment Type

Before you connect the serial port pins on the aforementioned terminals (DCE units) to external equipment, you need to determine if the external hardware serial ports are configured as DTE or DCE. The FALCOM BOLERO-LT is designed for use as a DCE. Based on the aforementioned conventions for DCE-DTE connections it communicates with the customer application (DTE) using the following signals:

BOLERO-LT Terminal (DCE)	to	Application (DTE)
RxA	<-----	TXD
TxA	----->	RXD

**Table 6:** The signalling definitions between DTE and DCE.

## 6 HARDWARE INTERFACES

### 6.1 6-pin connector



Figure 4: View of the 16-pin connector pin assignments

#### 6.1.1 Pin assignment on the 6-pin connector

PIN	NAME	I/O	DESCRIPTION	LEVEL
1	RxA	I	RS232 serial interface (receive data) for direct connection . If not used leave open.	V <sub>24</sub> , ±12 V
2	TxA	O	RS232 serial interface (transmit data) for direct connection. If not used leave open.	V <sub>24</sub> , ±12 V
3	+IN	I	Power supply input (Input 7). The power supply must be able to meet the requirements of current consumption. Care must be taken so that the operating voltage applied to the terminal stay within the voltage range. Applying a voltage outside of the voltage range can damage the unit.	V <sub>i</sub> = +10.8 ... +35.0V; I <sub>max</sub> ≤ 2A
4	GND	-	Ground.	0 V
5	IGN	I	General purpose input. Either connect it to the vehicle ignition and use it for journey START and STOP reports or connect it to the operating voltage +IN and with the help of an external switch you are able to wake up the BOLERO-LT device from IGN-Sleep mode ( <i>sending into the IGN-Sleep mode this pin should be low while awaking from this mode requires a HIGH signal</i> ). See also chapter 6.1.2.4.	<b>HIGH</b> ≥+10.8 .. +35.0 V DC; <b>LOW</b> = 0V
6	IO1	I/O	Individually software configurable as digital or analog input or digital output. In the software it corresponds to <b>IO0</b> if used as input or <b>IO4</b> if used as output.	<b>Analog IN</b> : Up to 35.0 V DC/10 bits resolution
				<b>IN</b> : +0 ... +35.0 V DC ( <b>High</b> and <b>Low</b> programmable by the software)
				<b>OUT</b> : 100 mA @ +10.8 ... +35.0 V DC

Table 8: Pin assignment and description of 6-pin connector

### 6.1.2 Special pin description

For the IO lines that can work as input or output the corresponding output of this pin has to be set to high (with PFAL command “\$PFAL,IO4.Set=high”), otherwise 0V will be measured (and the device could be damaged).

#### 6.1.2.1 Analog input (6)

Analog voltage up to 35.0 V with 10 bit resolution can be processed and remotely evaluated by a server application. Pull-up resistor to a constant input voltage allows for resistive transducers to ground, e.g. fuel sensor or thermistors. *Because the pin 6 can operate either as digital or analog, it has to be configured and calibrated for such purposes before using.*

To use these IOs as analog inputs, the following configuration is required in the software.

**PFAL,IO0.Config=AI,2,11**

**PFAL,IO0.Config=DI,3,6**

*where 0 is the index corresponding to IO1 (pin 6). The strings AI and DI are identifiers for analog and digital input respectively. While the value after strings e.g. 3 and 6 are min. and max. voltages that will be used to generate Low and High events respectively. Detailed information can be found in software manual “stepplll\_fox\_bolero\_lt\_PFAL\_Configuration\_Command\_Set.pdf”.*

##### 6.1.2.1.1 Connection example using IO1 as analog inputs:

This pin can be connected to a temperature sensor (a NTC resistor for instance). Therefore, you can set a low and high temperature alarm. Passage through these thresholds will trigger an alarm. As alarm type you can use an SMS or a TCP with GPIOP as attachment protocol. The SMS contents can be sent to a mobile phone. An application example is shown in figure below:

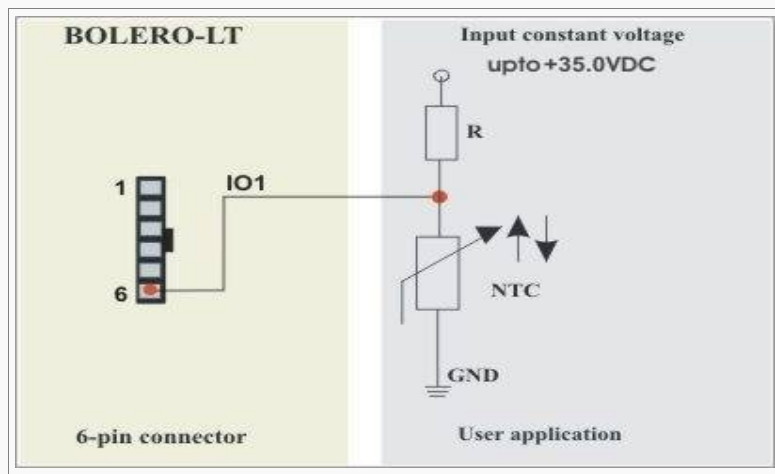

Figure 5: Connection example for analog input (IO1)

**This circuit example is only an illustration to show the aim of the analog input.**

### 6.1.2.2 Digital Input (pin 6)

This pin is a high active when is used as digital input, so you can set  $V_{IN(Low)}$  and  $V_{IN(High)}$  to any levels within the range from +0 to +35.0 VDC. The High and Low levels have to be set by using the PFAL command (e.g. **PFAL,IO0.Config=DI,3,6**) - where 0 is the index corresponding to IO1 (pin 6). While the value 3 and 6 are min. and max. voltages that will be used to generate Low and High events respectively. Detailed information can be found in software manual "[steppIII\\_fox\\_bolero\\_lt\\_PFAL\\_Configuration\\_Command\\_Set.pdf](#)".

The figure below illustrates how to connect these pins and use them as digital inputs. When an input is activated, BOLERO-LT can release an alarm (for instance a SMS, TCP or GSM data connection). The alarm type and the alarm text are user dependent. These inputs can be configured by using the "[steppIII\\_fox\\_bolero\\_lt\\_PFAL\\_Configuration\\_Command\\_Set.pdf](#)" manual. Both inputs can be connected as shown below:

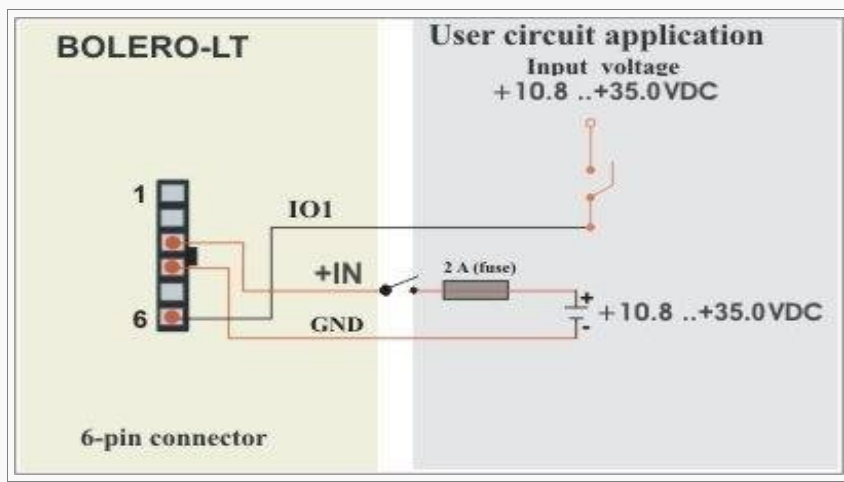

Figure 6: Connection example for digital input (IO1)

A completed circuit example for all inputs is attached in section [8.1.1](#).

### 6.1.2.3 Output (pin 6)

Pin 6 can also operate as a digital output. It is an open collector output. It can be directly connected via resistors (R) to LEDs, Relays etc., which need no more than 100 mA @ up to + 35.0 V DC. The figure below show the schematic of possible output connections. To use and activate this output use the command **\$PFAL,IO4.Set=high[low,hpulse,lpulse,cyclic]** for **IO1** or you can configure an alarm that activate this output when an specific event occur (e.g. **PFAL,Cnf.Set,AL0=IO.e8=redge:IO4.Set=cyclic,1000,2000**). In order to evaluate this alarm, firstly send this configuration to the BOLERO-LT device and then trigger IGN-pin to High – as result the IO1 goes High for 1 sec and Low for 2 sec. To set IO1 to Low, just execute the command **PFAL,IO4.Set=Low**. For more details how to activate an output and how to configure an alarm, refer to the manual **“stepIII\_fox\_bolero\_lt\_PFAL\_Configuration\_Command\_Set.pdf”**. *Please note that, no power should be applied directly to an output pin without having e.g. a resistor between output pin and power source.*

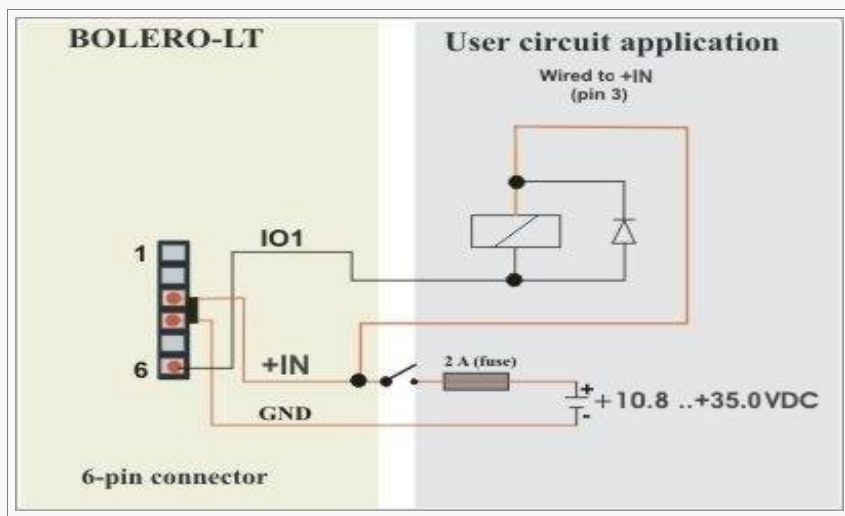

Figure 7: Connection example 1 for an output (Relay, IO1)

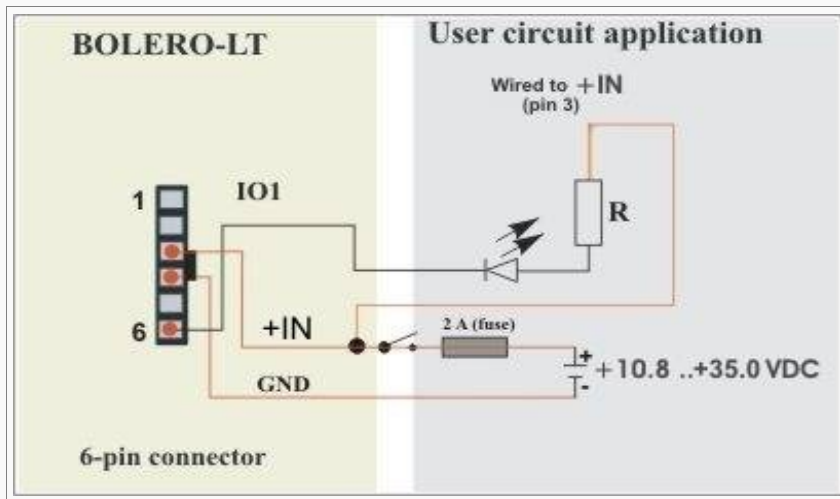

Figure 8: Connection example 2 for an output (LED, IO1)



### 6.1.2.4 How to use IGN pin ((pin 5)

The IGN-pin has two functions:

- ✓ It wakes up the system BOLERO-LT from the IGN-sleep mode (when sleeping),
- ✓ It can be used to monitor the vehicle ignition state, to report/store the START and STOP of a trip by using the events **IO.e8=redge** and **IO.e8=fedge** for **START** and **STOP** respectively.

IGN-sleep mode is one of the eight supported energy-saving modes of operation in which all unnecessary components are shut down. Once the device is awakened by IGN high signal, it returns to full functionality.

Note that, the IGN pin on the BOLERO-LT is not assumed to switch on the BOLERO-LT terminal, but to “wake up” the device from IGN-sleep mode.

Using IGN pin you can configure the system to store a specific location or to deliver an alarm SMS or TCP packet if an unauthorised person tries to start your vehicle. As an example, you can trigger the event caused by the status change of the Ignition to start the vehicle tracking.

**NOTE:** All BOLERO-LT devices that are shipped by the factory with an internal battery, are entered into the IGN-sleep mode. Therefore, to switch that sleep mode off and take the BOLERO-LT device back to full functionality, just connect it to the d.c.-power source and then set IGN-pin to High.

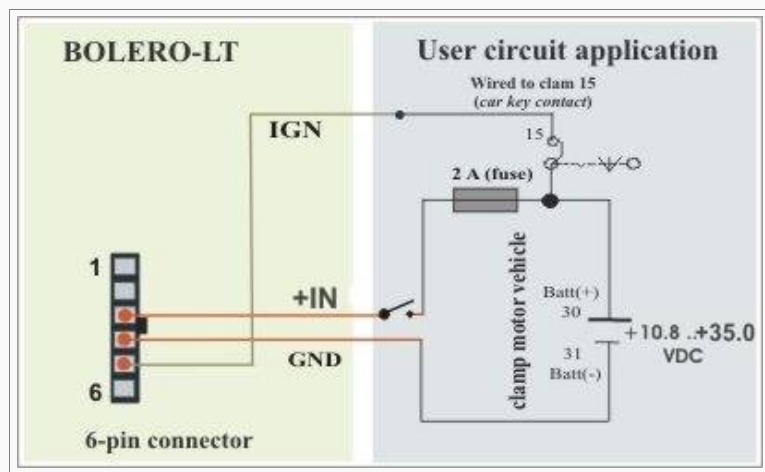

Figure 9: Vehicle ignition monitoring by IGN line

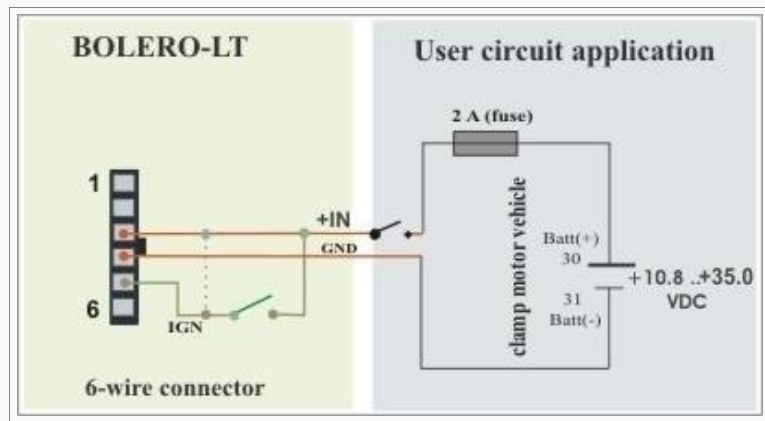

Figure 10: Use IGN line for awaking BOLERO-LT from IGN-Sleep

### 6.1.3 Buttons & LEDs

BOLERO-LT comes with 1 x free-programmable push-button (*connected to the DiWu-pin known in the STEPPIII*) and 3 x free-programmable LED indicators that can be used to indicate the status of different components in the the unit. The "On/Off" button generates (*IO.e9=redge*) event which can be used to power on the unit. However, you have the possibility to configure this button depending on what configuration is most important for you.



Figure 11: On/Off button

All LED indicators are accessible with PFAL commands and they can be interfaced to different components in the device to show their state. The mode and functionality of these LEDs are software controlled feature. References how to customize the device configuration, are available in the BOLERO-LT software manual "[stepIII\\_fox\\_bolero\\_lt\\_PFAL\\_Configuration\\_Command\\_Set.pdf](#)".



Figure 12: LED allocation

BOLERO device provides the following LED indicators		
Name	LED mode	Function
LED1	Free programmable	Free user programmable
LED2	Free programmable	Free user programmable
LED3	Free programmable	Free user programmable

Table 5: Modes of the LED's and associated functions

### 6.1.4 SIM card interface

The figure below shows the SIM card reader interface of the BOLERO-LT.



**Figure 13:** View of the SIM card interface

The SIM interface controls small 1.8/3 V SIM cards. This interface is fully compliant with GSM 11.11 recommendations concerning SIM functions.

**Note:** *The SIM should not be removed, while the unit is powered on. The SIM must only be removed when the **BOLERO-LT** is shut down. To remove the SIM card, press the Eject button (see figure 6) then pull out the SIM card-holder.*

### 6.1.5 Special pin description

#### 6.1.5.1 Serial communication signals (RxA, TxA )

The board supports one full duplex serial channel. All supported variable baud rates can be controlled from internal software. You can directly communicate with a PC serial port. It is recommended to use the BOLERO-LT Evalboard in order to communicate with the terminal.

#### **RS232 Level**

Serial interface (RxA, TxA) operates at V24,  $\pm 12$  V level. You do not need to use any level shifter for this serial port. The signals on these pins are obtained to RS232 compatible signal levels.

**RxA** *This is the main receiving channel and is used to receive software commands to the board from any terminal software (e.g. HyperTerminal) or from user written software. Firmware package can be sent through this line.*

**TxA** *This is the main transmitting channel and is used to output navigation and measurement data to any terminal software (e.g. HyperTerminal) or user written software.*

## 6.2 Mounting the BOLERO-LT device

The mounting location is very important, because it can affect the GPS reception quality. *Consider that the GPS receiving site of the unit is with the back viewing towards the sky.*

The double-side adhesive mounting plate included in the pack allows you to mount the unit BOLERO-LT somewhere on flat surfaces. When you have found a suitable place, make sure the mounting location provides an unobstructed line-of-sight and its surface is free of dirt and oil. Also clean the BOLERO-LT's back side. Remove one of the adhesive pad's yellow paper and attach it to the device's back side, then remove another one and attach the device back to the mounting location. Press the BOLERO-LT unit to avoid air bubbles.

### To assure maximum visibility of the satellites that provide positioning data:

- ✓ Mount the BOLERO-LT device on flat surfaces with the back facing towards the sky and relatively free of obstructions.
- ✓ For a proper reception of GPS signals, orient the unit at an angle from 0 to 60 degrees relative to the horizon (see fig. 14).
- ✓ Additionally, the mounting location must also be chosen far enough from electronic devices so that no interference takes place. Please, contact your vehicle supplier for more information.
- ✓ Failure to follow this installation instructions provided here, when installing this unit, can seriously degrade the performance of a GPS system .

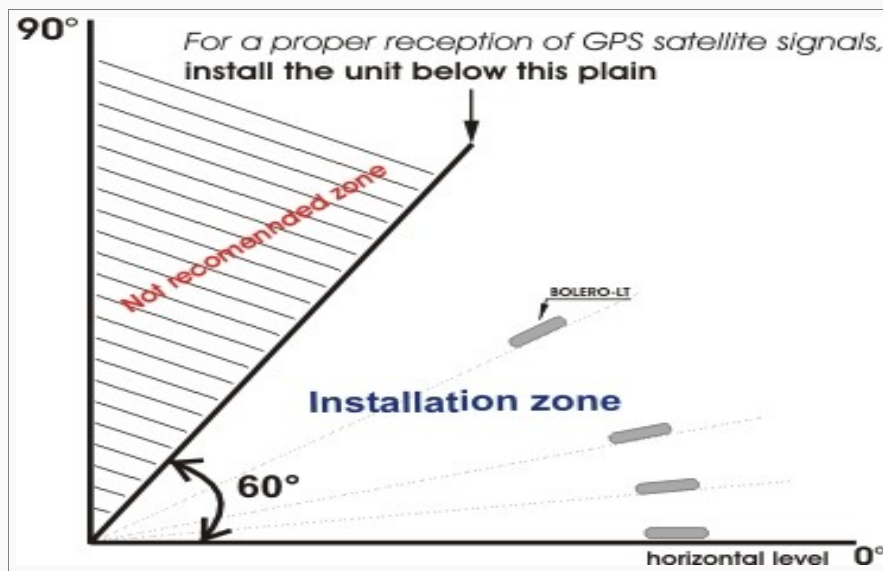

Figure 14: Installation area relative to the horizontal level

All radio-transmitting devices send signals, which may cause interference in different electronic devices (PC, television or electronic devices etc.). To avoid interference, place the terminal far enough from other electronic devices.

## 7 RF EXPOSURES

This device contains 850/900/1800/1900 MHz GSM/GPRS functions that is operational in these frequencies respectively.

The BOLERO-LT terminal contains 1800 MHz GSM functions that are not operational (must not be used) in U.S. Territories. Filing is only applicable for 850MHz GSM/1900 MHz PCS operations, whereby only these frequencies (850MHz GSM/1900 MHz PCS) are possible to be used in U.S. Territories.

### **Statement according to FCC part 15.19:**

This device complies with Part 15 of the FCC Rules. Operation is subject to the following two conditions:

- *this device may not cause harmful interference, and*
- *this device must accept any interference received, including interference that may cause undesired operation.*

### **Statement according to FCC part 15.21:**

Modifications not expressly approved by this company could void the user's authority to operate the equipment.

### **Statement according to FCC part 15.105:**

**NOTE:** This equipment has been tested and found to comply with the limits for a Class B digital device, pursuant to Part 15 of the FCC Rules. These limits are designed to provide reasonable protection against harmful interference in a residential installation. This equipment generates, uses and can radiate radio frequency energy and, if not installed and used in accordance with the instructions, may cause harmful interference to radio communications.

However, there is no guarantee that interference will not occur in a particular installation. If this equipment does cause harmful interference to radio or television reception, which can be determined by turning the equipment off and on, the user is encouraged to try to correct the interference by one or more of the following measures:

- *Reorient or relocate the receiving antenna.*
- *Increase the separation between the equipment and receiver.*
- *Connect the equipment into an outlet on a circuit different from that to which the receiver is connected.*
- *Consult the dealer or an experienced radio/TV technician for help.*

## 8 APPENDIX

### 8.1 Schematics

The figure below illustrates a common schematic when you use the BOLERO-LT hardware for vehicle security. For detailed information, please, refer to the related documents [[AppNotes\\_in\\_vehicle\\_mounting.pdf](#)].

#### 8.1.1 Installation guidance for 6-pin connector

On the top-right of the schematic you can find the corresponding pin out of the 6-pin connector.

**1 x Power supply (+IN) :** Connect to the vehicle battery (clamp 30).

**1 x Ignition line (IGN) :** Connect to the vehicle starter lock (clamp 15) and use it for triggering alarms whenever the vehicle ignition key is closed (engine started). Or connect it to the operating voltage (+IN) to use the IGN-Sleep mode (see also Fig. 10.1)

The schematic below represents how these lines can be used.

The operating voltage range **MUST** never be exceeded. For security reason, it is recommended to integrate externally a 2A fuse link between the positive wire of the BOLERO-LT (+IN) and d.c. - power source.

Please note that, the ground pin of the BOLERO-LT should be isolated from the vehicle body to avoid ground loops.

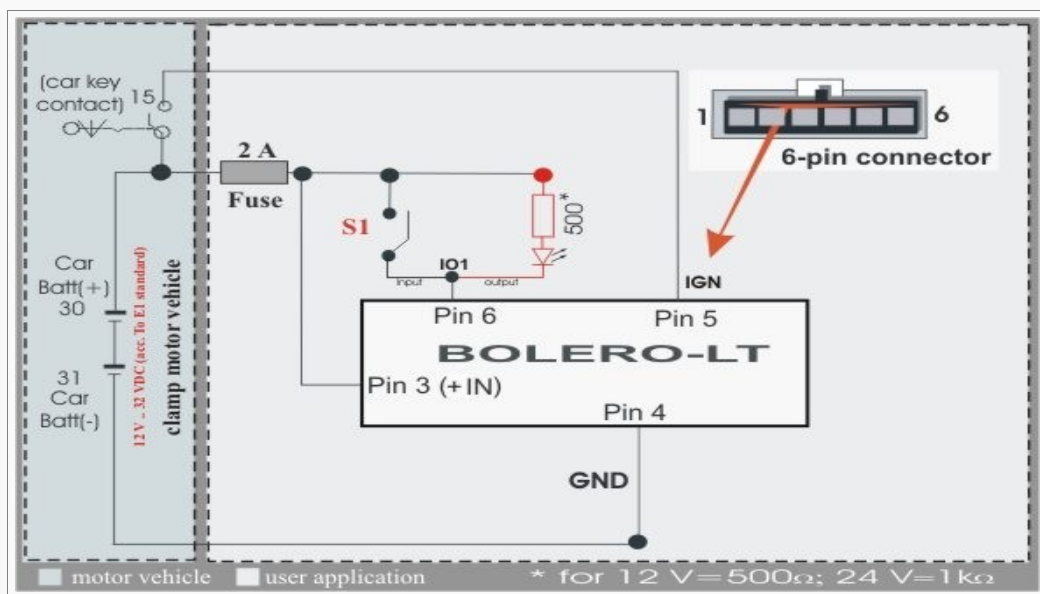

Figure 15: Schematic example of installation guidance