



- **FOX3 (2G)**

- **FOX3-3G**

- **FOX3-4G**

- **HARDWARE MANUAL**



Table of contents

| | |
|---|-----------|
| 1. Introduction | 7 |
| 1.1. General | 7 |
| 1.2. FOX3 Series hardware differences | 9 |
| 1.3. Package | 10 |
| 1.4. Circuit concept | 11 |
| 1.5. Related documents | 12 |
| 2. Disclaimer | 13 |
| 3. Security | 14 |
| 3.1. General information | 14 |
| 3.2. Exposure to RF energy | 14 |
| 3.3. Driving | 14 |
| 3.4. Electronic devices | 14 |
| 3.5. Vehicle electronic equipment | 14 |
| 3.6. Medical electronic equipment | 15 |
| 3.7. Aircraft | 15 |
| 3.8. Children | 15 |
| 3.9. Blasting areas | 15 |
| 3.10. Potentially explosive atmospheres | 15 |
| 3.11. Safety for Li-Ion batteries | 15 |
| 3.11.1. Safety precautions while charging the battery | 16 |
| 3.11.2. Safety precautions while discharging Li-Ion battery | 16 |
| 3.11.3. Safety precautions when replacing the battery | 16 |
| 3.12. Non-ionizing radiation | 16 |
| 4. Safety standards | 17 |
| 5. Technical data | 18 |
| 5.1. Product features | 18 |
| 5.1.1. Power consumption for FOX3/-3G/-4G | 20 |
| 5.1.2. Operating temperatures | 21 |
| 5.1.3. GSM/GPRS engine features | 22 |
| 5.1.4. GNSS engine features | 23 |
| 5.2. NMEA data message | 24 |
| 6. FOX3/-3G/-4G application interface | 25 |
| 6.1. Power supply | 25 |
| 6.1.1. Power supply pins (1 and 2) on the 8-pin connector | 25 |
| 6.1.2. Automatic shutdown | 25 |
| 6.1.3. Power saving | 26 |
| 6.2. Determining the External Equipment Type | 26 |
| 7. Hardware Interfaces | 27 |
| 7.1. Main Port (8pin connector) | 28 |
| 7.1.1. Main Port Pinout | 28 |

| | |
|---|-----------|
| 7.1.2. Installation cable (CA31-FOX3-KFZ-INST-1,5M-4x4) | 29 |
| 7.1.3. Special pin description (Pins 4, 5, 6) | 29 |
| 7.1.3.1. How to use I/O pins (4, 5, 6) as analog inputs | 30 |
| 7.1.3.2. How to use I/O pins (4, 5, 6) as digital Inputs | 31 |
| 7.1.3.3. How to use I/O pins (4, 5, 6) as digital outputs | 31 |
| 7.1.3.4. How to use IGN pin (pin 3) | 32 |
| 7.1.3.5. Serial Port 0 - Serial communication signals (RxA and TxA) | 33 |
| 7.2. Accessory Port (6pin connector) | 34 |
| 7.2.1. Accessory Port Pinout | 34 |
| 7.2.2. 1-Wire interface description | 34 |
| 7.2.2.1. Serial Port 1 - Serial communication signals (RxA_1 and TxA_1) | 35 |
| 7.3. Inserting a SIM card into the SIM holder | 36 |
| 7.3.1. How to enter the PIN of the inserted SIM card | 37 |
| 7.4. LED indicators | 38 |
| 7.5. 10pin mini-USB port | 38 |
| 7.5.1. Setting up a USB connection for FOX3/-3G/-4G | 39 |
| 7.5.1.1. Installing the CDC driver files for FOX3/-3G/-4G | 39 |
| 7.5.2. IOBOX-MINI/CAN accessory devices for FOX3/-3G/-4G | 41 |
| 7.5.2.1. Connecting IOBOX-MINI/CAN to FOX3/-3G/-4G | 41 |
| 7.5.2.2. IOBOX-MINI pinout | 42 |
| 7.5.2.3. IOBOX-CAN pinout | 43 |
| 7.6. Mounting | 44 |
| 7.6.1. External Antenna Ports | 45 |
| 7.7. Audio Interface | 46 |
| 8. Housing | 47 |
| 9. RF Exposures | 48 |
| 9.1. RF Exposures - English | 48 |
| 9.2. Exposition RF - French | 49 |
| 10. Appendix | 50 |
| 10.1. Schematics | 50 |
| 10.1.1. Installation guidance | 50 |
| 10.2. What should be considered when using FOX3/-3G/-4G device | 51 |
| 10.3. GPRS Coding scheme | 51 |

Version history:

This table provides a summary of the document revisions.

| Version | Author | Changes | Modified |
|---------|-----------|--|------------|
| 2.2.3 | F. Beqiri | - Added RF exposures in both English and French (chapter 9) | 12/22/2016 |
| 2.2.2 | F. Beqiri | - Added CA31 accessory – the main port installation cable with 2A fuse – see chapter 7.1.2 | 10/27/2016 |
| 2.2.1 | F. Beqiri | - Added FOX3-4G. There are two models of FOX3-4G available: FOX3-4G-NA , FOX3-4G-EU - Added all models of FOX3 series – See chapter 1.1 - Added table in chapter 1.2 - FOX3 series hardware differences. - Added power consumption for FOX3-3G and FOX3-4G. Updated power consumption for FOX3 - See chapter 5.1.1 - Added operation frequencies for FOX3-3G and FOX3-4G – See chapter 5.1.3 - Changed USB driver from FTDI to CDC. - Added new audio cable “ CA81b ” with with an integrated transformer that provides a full galvanic isolation - See chapter 7.7, Audio Interface | 10/08/2016 |
| 2.1.1 | F. Beqiri | - Internal information | Cancelled |
| 2.1.0 | F. Beqiri | - Added FOX3-3G. There are four models of FOX3-3G available: FOX3-3G , FOX3-3G-LITE , FOX3-3G-AUDIO and FOX3-3G-BLE . Only FOX3-3G-AUDIO . Only FOX3-3G , FOX3-3G-AUDIO and FOX3-3G-BLE are expandable via IOBOX-MINI , IOBOX-CAN and IOBOX-BTLE . | 10/05/2016 |
| 1.0.9 | F. Beqiri | - Updated power consumption - See chapter 5.1.1 - Updated chapter 7.5.2 - Connecting the IOBOX-CAN - Added chapter 7.5.2.3 - IOBOX-CAN pinout - Added the audio cable with integrated transformer and galvanic isolation (CA81b) - see chapter 7.7 | 20/07/2015 |
| 1.0.8 | F. Beqiri | - Unnamed: PAID-FEATURE in PREMIUM-FEATURE | 19/02/2015 |
| 1.0.7 | F. Beqiri | - Added point 6 in chapter 7.5.1.1 - Activation of the setting/option "Load-VCP" after installing the FTDI driver. | 10/27/2014 |
| 1.0.6 | F. Beqiri | - Added chapter 3.11.3, "Safety precautions when replacing the battery" | 10/24/2014 |
| 1.0.5 | F. Beqiri | - Added power consumption @ 24 VDC - see Table 3.1 | 01/07/2014 |
| 1.0.4 | F. Beqiri | - Added: KA70 (3-Wires installation cable (V+, GND, IGN) - optional accessory) | 16/05/2014 |
| 1.0.3 | F. Beqiri | - Added: Power consumption @ 12 VDC - see chapter 5.1.1 - Added: Installing USB drivers - see chapter 7.5.1.1 | 14/05/2014 |
| 1.0.2 | F. Beqiri | - Added figure 1 in chapter 1.1 | 30/01/2014 |
| 1.0.1 | F. Beqiri | - Chapter 7.1.3 updated | 27/01/2014 |
| 1.0.0 | F. Beqiri | - Initial version. | 15/12/2013 |

Cautions

The information furnished herein by FALCOM is believed to be accurate and reliable. However, no responsibility is assumed for its use. Please, read carefully the safety precautions.

If you have any technical questions regarding this document or the product described in it, please contact your vendor.

General information about FALCOM and its range of products are available at the following Internet address: <http://www.falcom.de/>

Trademarks

Some mentioned products are registered trademarks of their respective companies.

Copyright

This document is copyrighted by **FALCOM GmbH** with all rights reserved. No part of this documentation may be reproduced in any form without the prior written permission of **FALCOM GmbH**.

FALCOM GmbH

No liability (incl. patent liability) is assumed with respect to the use of the information contained herein.

Note

Because our products are being continuously improved, specifications and information given in this document are subject to change by FALCOM without notice.

1. INTRODUCTION

This product manual is only addressed to qualified personnel who are well skilled in electrical/electrical installation and not to the private consumers/end users. The installation, implementing or setting into operation of the product can be performed only by qualified personnel.

The product status described in this document may have changed since first publication and therefore the information in this document about the product status may be outdated. The latest product information is available in the download area of the FALCOM website.

The engineering of the FOX3/-3G/-4G products is built on the same technology combining both versions of the FOX-IN/EN devices with additional hardware extensions and mobile communications technology into one product. The main characteristic of these products is the on-board auto-switch that it supports connection to both internal and external antennas by automatically switching to the external antennas when connected. These AVL products are the first design to feature a hardware implementation of this technology.

1.1. General

FALCOM is using state-of-the-art technology to develop unique and low-cost devices for managing assets and vehicle tracking more effectively than current systems on the market today. FOX3/-3G/-4G are compact and all-in-one devices with powerful integration capability. There are three models of FOX3 series available: **FOX3** with 2G communication network, **FOX3-3G** with UMTS/HSPA communication networks and **FOX3-4G** with LTE. FOX3-3G supports fall back to GPRS and EDGE when UMTS or HSPA are not available and FOX3-4G supports fall back to HSPA and EDGE, GPRS when LTE is not available.

| Devices | Device series | | | |
|---------|---------------|----------------|---------------|-------------|
| FOX3 | FOX3 (2G) | FOX3 (2G)-LITE | | |
| FOX3-3G | FOX3-3G | FOX3-3G-LITE | FOX3-3G-AUDIO | FOX3-3G-BLE |
| FOX3-4G | FOX3-4G | FOX3-4G-NA | FOX3-4G-EU | |

Only **FOX3**, **FOX3-3G-AUDIO** supports audio for speaker and microphone. The FOX3 series provide analog ports and integrates with 1-Wire interface. The 1-Wire interface supports connection with multiple sensors such as iButton, Temperature Logger, Temperature Sensor, Humidity sensor.



Figure 1: FOX3/-3G/-4G networking and interfaces to peripheral devices.

Newly developed FALCOM PREMIUM features show the way to the future of mobile data logging, storing, processing and sending. The needed hardware options can be decided shortly before installation depending on the application. FOX3/-3G/-4G can act as a mobile client for various regular applications like AVL, fleet management, security and recovery of assets. The device offers new firmware features like: TCP DATA ENCRYPTION, several HISTORY MODES and ECO-DRIVE/BEHAVIOUR LOGGING beside standard items like status reports, messaging alerts, audio calls, spy calls and Geo-fencing.

The FOX3/-3G/-4G units are delivered without SIM card and without battery. SIM cards must first be purchased and then registered into the GSM network before installing into the device. The battery can be ordered as an option (refer to the Ordering Guide for more information). The setup and configuration of the device is provided through Serial Ports, over SMS and TCP using special commands like "PFAL" and the Workbench Software configuration tool. These "PFAL" commands are special to FALCOM AVL devices and can be used for all kinds of communications including Serial, SMS, CSD, TCP and SMTP. Please read the document "*AVL_PFAL_Configuration_Command_Set.pdf*" for more details about the PFAL-Commands.

Geofence features for territory management, route verification, prohibited locations, parking area and more with exception reporting to a wide variety of events, such as arrivals, departures, deliveries, pick-ups, illegal entries, unauthorized movement, etc are also implemented in the firmware. FOX3/-3G/-4G contain a data-logger (history feature) that enables archiving of unique vehicle locations in sequence up to 45 days for later analysis and evaluation, for example with an archiving interval up to 20 sec..

The physical interface to the devices application is made through integrated main and accessory ports as well as the 10pin mini-USB port. These ports are required for controlling the units, receiving GPS location data, transferring data, power supply, extending the number of I/Os as well as for the use of extra external devices which are not integrated in the In-Vehicle Computers.

FOX3/-3G/-4G are devices that can be configured and integrated onto any asset platform, including:

- Trailers
- Trucks
- Delivery vans
- Rail cars
- Industrial vehicles and more

and can be used in a variety of applications, including:

- Real time online tracking
- Fleet management / monitoring
- Security / emergency services
- Real time satellite navigation
- Territory management
- Personalized drivers logbook
- Route verification
- Trip management / Distance calculations
- Theft protection
- Toll collection / pay as you drive
- Eco-Drive - (PREMIUM feature)
- Encrypted TCP communication based on AES 128 bit algorithm - (PREMIUM feature) and more.

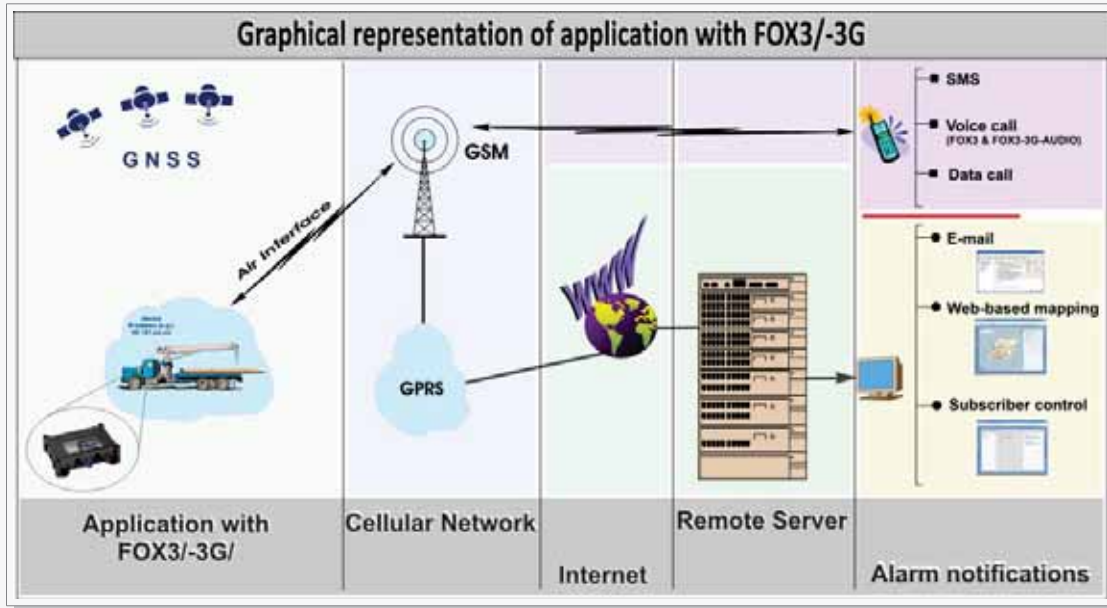

Figure 2: GSM/GPRS and GPS based vehicle tracking applications with FOX3/-3G/-4G

1.2. FOX3 Series hardware differences

The following table shows the hardware differences between FOX3 series models.

| Device models | Serial 0 | Serial 1 | 1-Wire | USB | Int/Ext Antenna | Audio | Bluetooth LE |
|----------------|----------|----------|--------|-----|-----------------|-------|--------------|
| FOX3 (2G) | x | x | x | x | x | x | |
| FOX3 (2G)-LITE | x | | | x | x | | |
| FOX3-3G | x | x | x | x | x | | |
| FOX3-3G-LITE | x | | | x | x | | |
| FOX3-3G-BLE | x | x | x | x | x | | x |
| FOX3-3G-AUDIO | x | x | x | x | x | x | |
| FOX3-4G-NA | x | x | x | x | x | TBD | |
| FOX3-4G-EU | x | x | x | x | x | TBD | |

Table 1: Hardware differences

1.3. Package

FOX3/-3G/-4G devices are shipped in a cardboard box with following content:



Figure 3: FOX3/-3G/-4G standard delivery

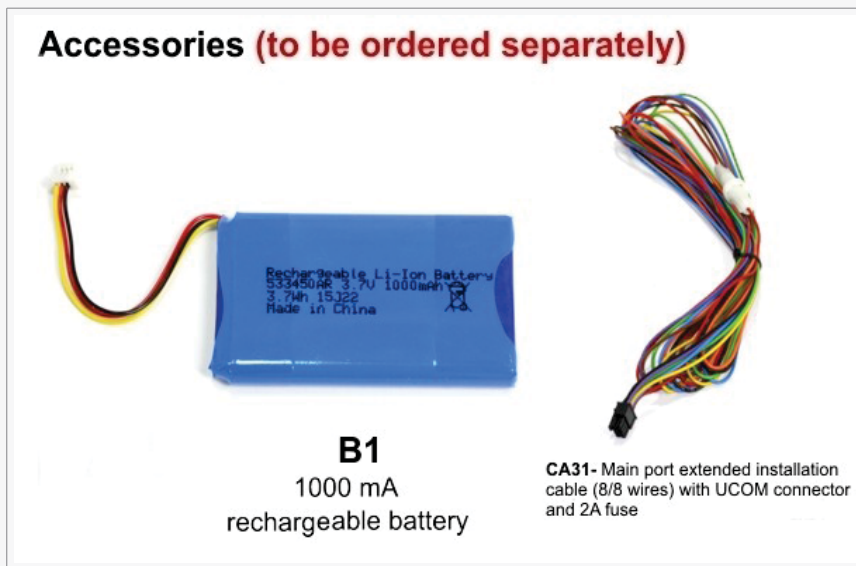

Figure 3.1: FOX3/-3G/-4G basic accessories (to be ordered separately)

Please refer to the FALCOM ordering guide for more details about the availability of other accessories.

1.4. Circuit concept

The architecture of the FOX3/-3G/-4G devices consist of the following major components (as shown below):

| Architecture Integrates | |
|---|--|
| - Quad-Band GSM/GPRS module or 3G /4Gmodule | |
| - GNSS receiver (GPS + GALILEO + GLONASS) - GLONASS needs to be activated | |
| - ARM7 processor controlling system functions | |
| - Inside SIM card holder (1.8/3V SIM cards) | |
| - Internal GSM/GNSS antennas | |
| - Main Port (Power, RS232 port, I/O ports) | |
| - Accessory Port (1-Wire, RS232 port, I ² C interface) | |
| - 10pin mini-USB-connector (incl. SPI & USB) | |
| - Audio connector (Microphone & Speaker) - for FOX3 & FOX3-3G-AUDIO | |
| - GSM & GNSS antenna ports (for external antennas) | |
| Physical Interfaces | FOX3/-3G/-4G accessories and hardware PREMIUM features |
| - 1 x Power supply lines | - Backup battery 1000 mAh (B1 Option) |
| - 3 x Multi-line I/O | - IOBOX-MINI - I/O extension module |
| - 1 x Ignition | - IOBOX-CAN - Second CAN-Bus interface |
| - 3 x LED indicators | - Car installation cable (more cables in the Ordering Guide) |
| - 2 x RS232 port (RX, TX, GND) V24 | - CAN-Bus Interface |
| - 1 x 2.5mm audio port | - RS485 port |
| - 1 x USB port | |
| - 1 x SPI interface (for IOBOX-MINI/ BT / CAN) | |
| - 1 x 1-Wire port | |
| - 1 x I ² C port | |
| - 2 x External antenna port | |
| - 8 x Mounting Holes | |

Table 2: FOX3/-3G/-4G architecture

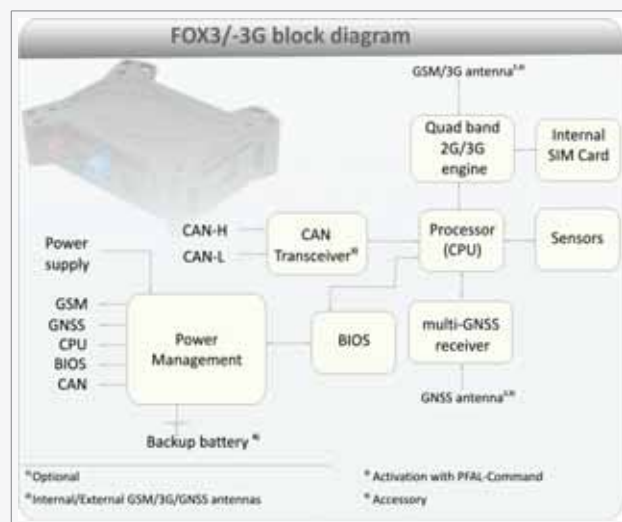

Figure 4: FOX3/-3G/-4G block diagram

1.5. Related documents

In addition to this document, the following files comprise the full set of FALCOM FOX3/-3G/-4G product manuals:

| NR | PDF file name | Description |
|------|--|--|
| [1] | AVL_PFAL_Configuration_Command_Set.pdf | Contains the description of the internal firmware and the supported Configuration Command Set for the AVL devices. |
| [2] | AppNotes_Transform_history_data.pdf | Contains information of how to decode history data that are being transmitted from a FALCOM AVL device via TCP connection. |
| [3] | AppNote_Remote_update.pdf | Contains information of how to upgrade FALCOM AVL devices to a new firmware revision remotely via TCP (server based application). |
| [4] | AppNotes_AVL_Installation_Guide.pdf | This document provides all the necessary information how to install your FALCOM product properly and safely in a vehicle. |
| [5] | AppNotes_ECO-DRIVE-GPS.pdf | This document contains information of how to use the features of the GPS-ECO-DRIVE supported as PREMIUM-FEATURE in the firmware version avl_2.11.0 and above. |
| [6] | AppNotes_AES_TCP.pdf | This document contains information of how to use the features of the AES_TCP (ADVANCED ENCRYPTION STANDARD) supported as PREMIUM-FEATURE in the firmware version avl_2.10.0 and above. |
| [7] | AppNotes_HowToActivatePremiumFeatures.pdf | This document contains information of how to activate a PREMIUM-FEATURE on a FALCOM AVL device. |
| [8] | AVL_AppNote_RFID_Howto.pdf | This document contains information of how to connect and use an RFID-Reader to/with the FALCOM AVL devices. |
| [9] | AppNotesForCANBusApplication.pdf | This document contains information of how to connect an the FALCOM AVL devices to the vehicle and how to configure and use the CAN-Bus features. |
| [10] | AppNote_CAN_FMS_CAN_OBDII_Howto.pdf | This document contains information of how to connect an the FALCOM AVL devices to the vehicle and how to configure and use the CAN-Bus/FMS/OBDII features. |
| [11] | AppNote_WebUpdate_Howto.pdf | This document contains information of how to upgrade an AVL device firmware remotely over the air. |
| [12] | AVL_STEPIII_AppNote_Connecting_Barcode_Scanner.pdf | This document contains information of how to connect a bar code scanner to a FALCOM AVL device and how to transmit the scanned data. |
| [13] | STEPPIII_FOX_BOLERO_LT_Software_Update.pdf | Contains information how to upgrade a FALCOM AVL device to a new firmware version locally via serial port. |
| [14] | AppNotesRemoteUpdateWithWorkbench.pdf | Contains information how to upgrade a FALCOM AVL devices to a new firmware version remotely via TCP. |
| [15] | AppNote_1-Wire_Guide.pdf | Contains information how to use the 1-Wire interface on the FOX3/-3G/-4G devices. |

These PDF files are viewable and printable from Adobe Reader. If you do not have the Adobe Reader installed, you can download it from <http://www.adobe.com>.

2. DISCLAIMER

This section explains our disclaimer concerning any application the customer may develop with FALCOM AVL devices.

- (1) Due to the large variety of supported applications with FALCOM AVL devices, FALCOM is not able to test all such types of applications.
- (2) The customer is solely responsible for proper use of the products and for a long-term test of the developed applications.
- (3) All applications are highly influenced by environmental conditions, correct handling, installation and device configuration/programming. FALCOM don't assume any responsibility for correct work of customer application and any results like damaging or losses on non-working .
- (4) FALCOM is not responsible for and disclaims all warranties of any kind with respect to third-party products and is also not responsible for any damages caused by use of the third-party products in any combination with the FALCOM devices. FALCOM can not assure that third-party products will operate technically trouble free in use with the FALCOM products.
- (5) We recommend to perform a reasonable test of your application before deploying into the field. The test should be also performed on any modification of configuration/programming, firmware update or any other changes made on the connected devices or peripherals also before deploying the change into the field. The environmental conditions and the duration of these tests should reflect the conditions of the real use case/installation.

3. SECURITY

IMPORTANT FOR THE EFFICIENT AND SAFE OPERATION OF YOUR GSM-MODEM, READ THIS INFORMATION BEFORE USE!

Your cellular engines FOX3/-3G/-4G are one of the most exciting and innovative electronic products ever developed. With them, you can stay in contact with your office, your home, emergency services and others, wherever service is provided.

This chapter contains important information for the safe and reliable use of the FOX3/-3G/-4G devices. Please read this chapter carefully before starting to use the cellular engines FOX3/-3G/-4G.

3.1. General information

Your FOX3/-3G/-4G devices utilize the GSM/GNNS standard for cellular technology. GSM is a newer radio frequency („RF“) technology than the current FM technology that has been used for radio communications for decades. The GSM standard has been established for use in the European community and elsewhere. Your FOX3/-3G/-4G are actually a low power radio transmitter and receiver. They send out and receives radio frequency energy. When you use your modem, the cellular system handling your calls, controls both the radio frequency and the power level of your cellular modem.

SIM cards are needed for the use of the acquired devices, which are not included in the scope of delivery of the device. The SIM cards can be acquired e.g. by specific providers. Additional costs can result from the use of the SIM cards which are to be borne by the purchaser (client) of the devices. The seller does not cover the extra costs for the use of the devices. The seller gives no recommendation for the use of specific SIM cards and is not liable for the fact that the devices are usable with all available SIM cards. The seller is also not liable for any other costs that are needed for the application of the customer in connection with this device.

3.2. Exposure to RF energy

There has been some public concern about possible health effects of using GSM modems. Although research on health effects from RF energy has focused for many years on the current RF technology, scientists have begun research regarding newer radio technologies, such as GSM. After existing research had been reviewed, and after compliance to all applicable safety standards had been tested, it has been concluded that the product is fit for use.

If you are concerned about exposure to RF energy, there are things you can do to minimize exposure. Obviously, limiting the duration of your calls will reduce your exposure to RF energy. In addition, you can reduce RF exposure by operating your cellular modem efficiently by following the guidelines below.

3.3. Driving

Check the laws and regulations on the use of cellular devices in the area where you drive. Always obey them. Also, when using your FOX3/-3G/-4G while driving, please pay full attention to driving, pull off the road and park before making or answering a call if driving conditions so require. When applications are prepared for mobile use, they should fulfil road-safety instructions of the current law!

3.4. Electronic devices

Most electronic equipment, for example in hospitals and motor vehicles is shielded from RF energy. However, RF energy may affect some malfunctioning or improperly shielded electronic equipment.

3.5. Vehicle electronic equipment

Check your vehicle manufacturer's representative to determine if any on board electronic equipment is adequately shielded from RF energy.

3.6. Medical electronic equipment

Consult the manufacturer of any personal medical devices (such as pacemakers, hearing aids, etc.) to determine if they are adequately shielded from external RF energy.

Turn your FOX3/-3G/-4G devices OFF in health care facilities when any regulations posted in the area instruct you to do so. Hospitals or health care facilities may be using RF monitoring equipment.

3.7. Aircraft

Turn your FOX3/-3G/-4G OFF before boarding any aircraft. Use them on the ground only with crew permission. Do not use them in the air.

To prevent possible interference with aircraft systems, Federal Aviation Administration (FAA) regulations require you to have permission from a crew-member to use your modems while the plane is on the ground. To prevent interference with cellular systems, local RF regulations prohibit using your modems whilst airborne.

3.8. Children

Do not allow children to play with your FOX3/-3G/-4G devices. It is not a toy. Children could hurt themselves or others (by poking themselves or others in the eye with the antenna, for example). Children could damage the modems or make calls that increase your modem bills.

3.9. Blasting areas

To avoid interfering with blasting operations, turn your device OFF when in a “*blasting area*” or in areas posted: „*turn off two-way radio*“. Construction crew often uses remote control RF devices to set off explosives.

3.10. Potentially explosive atmospheres

Turn your FOX3/-3G/-4G devices **OFF** when in any area with a potentially explosive atmosphere. It is rare, but your modems or their accessories could generate sparks. Sparks in such areas could cause an explosion or fire resulting in bodily injury or even death. Areas with a potentially explosive atmosphere are often, but not always, clearly marked. They include fuelling areas such as petrol stations; below decks on boats; fuel or chemical transfer or storage facilities; and areas where the air contains chemicals or particles, such as grain, dust or metal powders. Do not transport or store flammable gas, liquid or explosives, in the compartment of your vehicle, which contains your modem or accessories.

Before using your modems in a vehicle powered by liquefied petroleum gas (such as propane or butane) ensure that the vehicle complies with the relevant fire and safety regulations of the country in which the vehicle is to be used.

3.11. Safety for Li-Ion batteries

The FOX3/-3G/-4G devices are shipped without battery inside. If a backup battery is needed, please refer to the FALCOM Ordering Guide and follow the safety rules listed below.

The safety rules below are applied for the Li-Ion internal battery. Lithium-Ion (abbreviation: Li-Ion) batteries require particularly careful handling. This applies to charging and discharging techniques, and also to storage and other aspects of general handling. Mistreating the battery may cause the battery to get hot, crack, or inflame and cause serious injury. In order to avoid any damage and extend the life expectancy of battery, please follow the safety rules listed below before using FOX3/-3G/-4G devices with battery option:

- Do not place the battery on, in or near fires, apparatus that provide heat, or other high-temperature locations. Do not place the battery in direct sunshine, or use or store the battery inside cars in hot

weather. Doing so may cause the battery to generate heat, crack, or inflame. Using the battery in this manner may also result in a loss of performance.

- Do not attach the battery to a power supply plug or directly to a car's cigarette lighter.
- Do not pierce the battery with nails, strike the battery with a hammer, step on the battery, or otherwise subject it to strong impacts or shocks.
- Do not solder onto the battery contacts.
- Do not allow the battery to get wet.
- Do not disassemble or modify the battery.
- Immediately discontinue use of the battery if, while using, charging, or storing the battery, the battery emits an unusual smell, feels hot, or appears abnormal in any other way.
- Do not place the batteries in microwave ovens, high-pressure containers, or on induction cookware.
- In case the battery drips and the fluid gets into one's eye, do not rub the eye. Rinse well with water and immediately look for medical care. If left untreated the battery fluid could cause damage to the eye.

3.11.1. Safety precautions while charging the battery

Be sure to follow the rules listed below while charging the battery. Failure to do so may cause the battery to become hot, rupture, or ignite and cause serious injury.

- When charging the battery insure that the battery charging conditions specified are met. The temperature range over which the battery can be charged is 0°C to 40°C. Charging is interrupted, if the ambient temperature is outside of this range.

3.11.2. Safety precautions while discharging Li-Ion battery

The temperature range over which the battery can be discharged is -20°C to 60°C. Use of the battery outside of this temperature range may damage the performance of the battery or may reduce its life expectancy.

3.11.3. Safety precautions when replacing the battery

The following notes describe information that you must consider when replacing the battery. The lithium battery must be handled correctly to avoid possible danger.

Replace the battery only with the same battery that comes with the device. Use of another battery invalidates all warranty claims for the device.



Caution: risk of explosion if battery is replaced by an incorrect type.

Dispose of the used battery as required by local ordinances or regulations.

3.12. Non-ionizing radiation

The FOX3/-3G/-4G devices come with internal and external GSM/3G/4G/GNSS antennas. Therefore, care should be taken to install the devices/antennas in such a position that no part of the human body will normally rest within 20 cm of any part of the antennas for more than a few minutes whilst the equipment is in use. It is also recommended to use the devices not close to medical devices as for example hearing aids and pacemakers.

4. SAFETY STANDARDS

Your GSM/GPRS/3G/4G/GNNS devices complies with all applicable RF safety standards.

FOX3/-3G/-4G meet the safety standards for RF receivers and the standards and recommendations for the protection of public exposure to RF electromagnetic energy established by government bodies and professional organizations, such as directives of the European Community, Directorate General V in matters of radio frequency electromagnetic energy.

5. TECHNICAL DATA

5.1. Product features

↳ Supply voltage range:

- Operating power supply voltage range of +10.8 V to +32.0 V, suitable for direct connection to an automotive +12V or +24V DC power source (vehicle battery).

↳ Power saving:

- 10 different energy-saving modes - programmable with PFAL commands. See chapter 6.1.3 for more details.

↳ Operating temperature range:

- - 40°C to + 85°C (see chapter 5.1.2 for more details).

↳ Physical characteristics:

- Size: 83.0 ± 0.5 mm x 105 ± 0.5 mm x 28.0 ± 0.5 mm
- Weight (without battery): ca. 130 gr.

↳ Physical Interfaces:

- Main Port (8pin row connector) comprising:
 - ✓ 3 x I/Os multi functional pins (each pin has dual functions as analog or digital - software configurable. Each digital pin can individually be set as an input or output)
 - ✓ 1 x Ignition pin (software controlled feature)
 - ✓ 1 x Power supply (software controlled feature)
 - ✓ 1 x Serial port (Rx, Tx), Baud rate is controlled by firmware 4800...115200 bps (default=115200 bps), 8 data bits, no parity, 1 stop bit, no flow control.
- Accessory Port (6pin row connector) comprising:
 - ✓ 1-Wire line for connecting 1-Wire slave devices, such as iButton, temperature & humidity sensors etc.
 - ✓ I²C interface
 - ✓ 1 x Serial port (Rx, Tx), Baud rate is controlled by firmware 4800...115200 bps (default=115200 bps), 8 data bits, no parity, 1 stop bit, no flow control.
- 10pin mini-USB connector comprising:
 - ✓ USB port
 - ✓ SPI interface.
- Inside SIM card holder (supports 1.8/3 V SIM cards)
- Built-in 3D G-sensor for power management, motion and shock alarm
- 3 x LED indicators (red, green, blue) free-programmable
- External ports for connecting a GSM / GNSS antenna
- Audio interface with 2.5 mm female jack for connecting a headset (FOX3 & FOX3-3G-AUDIO).

↳ Accessories (to be ordered separately - see ordering guide):

- Backup Li-Polymer battery
- Car Installation Cable
- Accessory Installation Cable
- GSM/GNNS quad-band external antenna (FAL-ANT-11) for FOX3
- GSM/GNNS penta-band external antenna (FAL-ANT-12) for FOX3-3G
- GSM/GNNS penta-band external antenna (FAL-ANT-14) for FOX3-4G
- IOBOX-MINI (external I/O extension device - up to 13 inputs/outputs)
- IOBOX-CAN (external device with 2nd CANBus interface and 8 I/O)

↳ Casing:

- Fully shielded.

↳ Air humidity:

- 5 % up to 95 % (non-condensing).

↳ Directive:

- RoHS compliant (RoHS Directive 2002/95/EC)

↳ Firmware:

- Embedded TCP/IP stack, including TCP, IP, SMTP and UDP protocols
- Accessible via PFAL commands
- Upgradable locally via serial port and remotely over the air (OTA).

↳ Internal memory:

- 8 Mbyte FLASH for configuration, data-logging and firmware storage
- 2 MByte RAM.

↳ Supported protocols:

- NMEA Msg.: **GLL, GGA, RMC, VTG, GSV, GSA**
FALCOM Msg.: **IOP, GSM, AREA, 3DP, BIN** - see related documents [\[1\]](#) and [Table 5](#).

↳ GSM/3G/4G/GNSS antenna:

- Internal antennas and external antenna ports with built-in auto switch
- Connect / Disconnect event generation.

5.1.1. Power consumption for FOX3/-3G/-4G

All measurements have been performed with $T_{amb} = 23^{\circ}\text{C}$, $V_{IN+} = 12\text{ V DC}$; **FOX3**: DCS 1800 MHz, Power Level 10, Cell Power -75dBm; **FOX3-3G**: UMTS 2100 Mhz; FOX3-3G: LTE 800 MHz

| Modes | Average power consumption @ +12 V | | | | Comments |
|---------------------------|-----------------------------------|---------|---------|------|---|
| | FOX3 | FOX3-3G | FOX3-4G | Unit | |
| Max. | > 1 | > 1 | >1 | A | In a transmit burst the current consumption can rise to typical peaks of 1A |
| CPU on / GPS on / GSM off | 38 | 41 | 61 | mA | GPS-fix valid. |
| CPU on / GPS off / GSM on | 40 | 49 | 58 | mA | GSM idle (registered) and GPRS detached. |
| CPU on / GPS on / GSM on | 49 | 48 | 74 | mA | Power mode = disable, GPS fix valid, GPRS and TCP connected. |
| | 26 | 30 | - | mA | Power mode = auto, GPS fix valid, GPRS and TCP connected. |
| | 13 | 25 | - | mA | Power mode = doze, GPS fix valid, GPRS and TCP connected. |
| Transmit Data | 120 | 132 | 230 | mA | Sending data over TCP |

Table 3: Current consumption at 12 VDC

All measurements have been performed with $T_{amb} = 23^{\circ}\text{C}$, $V_{IN+} = 24\text{ V DC}$; **FOX3**: DCS 1800 MHz, Power Level 10, Cell Power -75dBm; **FOX3-3G**: UMTS 2100 Mhz; FOX3-3G: LTE 800 MHz

| Modes | Average power consumption @ +24 V | | | | Comments |
|--------------------------|-----------------------------------|---------|---------|------|---|
| | FOX3 | FOX3-3G | FOX3-4G | Unit | |
| Power mode = disabled | | | | | |
| Transmit Data | 60 | 68 | 94 | mA | Sending data over TCP |
| CPU on / GSM on /GPS on | - | - | 38 | mA | Microcontroller is ON, GPS fix valid, GPRS and TCP connected. |
| Power mode = Auto | | | | | |
| CPU on / GSM on /GPS on | 33 | 18 | - | mA | Microcontroller is ON, GPS fix valid, GPRS and TCP connected. |
| CPU on / GSM on /GPS off | 25 | 12 | - | mA | Microcontroller is ON, GPRS and TCP connected. |
| Power mode = Doze | | | | | |
| CPU on / GSM on /GPS on | 15 | 18 | - | mA | Microcontroller is ON, GPRS and TCP connected. |
| CPU on / GSM on /GPS off | 7 | 16 | - | mA | Microcontroller is ON, GPRS and TCP connected. |

Table 3.1: Current consumption at 24 VDC

| Sleep Modes | Average current consumption in sleep mode @ 12 V (external power) | | | Unit |
|-------------|--|---------|---------|------|
| | FOX3 | FOX3-3G | FOX3-4G | |
| IGN | < 1 | < 1 | < 1 | mA |
| IGN+Ring | 12 | 13 | 14 | mA |
| IGN+Timer | 1.5 | 2 | 3 | mA |
| IGN+GPS | 5 | 13 | 14 | mA |

Table 3.2: Power supply and current consumption for different sleep modes.

5.1.2. Operating temperatures

| Parameter | Min. | Typ. | Max. | Unit |
|---|------|------|------|------|
| Storage temperature | -40 | +25 | 85 | °C |
| Storage temperature | -20 | +25 | +60 | °C |
| Operating temperature | -40 | +25 | +85 | °C |
| GSM* | -30 | +25 | +80 | °C |
| Charging temperature (battery-operated **) | 0 | +25 | +45 | °C |
| Discharging temperature (battery-operated **) | -20 | +25 | +60 | °C |

* The GSM/GPRS module is fully functional (-20 °C to + 55 °C meets the 3GPP specifications).

** Optional. Storage and using conditions of the device with battery option are limited to the battery temperature range.

Table 4: Operating temperature for FOX3/-3G/-4G

5.1.3. GSM/GPRS engine features

↳ GSM/GPRS core:

| Device | Supported frequencies | | | | |
|------------|-----------------------|--------------|----------------------|------------|-------------------|
| | LTE | | UMTS | GSM/GPRS | |
| | Category | Bands | Bands | Slot class | Band |
| FOX3 | - | - | - | 10 | 850/900/1800/1900 |
| FOX3-3G | - | - | 850/900 1900/2100 | 10 | 850/900/1800/1900 |
| FOX3-4G-NA | 4 | 2,4,5,7,17 | 850/900 1900/2100 | 12 | 850/900/1800/1900 |
| FOX3-4G-EU | 4 | 1,3,5,7,8,20 | 850/900 900/2100 | 12 | 850/900/1800/1900 |

- All devices are compliant to GSM Phase 2/2+.
- FOX3-4G-NA is designed for operation in North America
- FOX3-4G-EU is designed for operation in Europe, Asia and other countries

↳ Output power:

- Class 4 (2 W) at EGSM900/850
- Class 1 (1 W) at GSM1800 and GSM 1900.

↳ GPRS connectivity:

- GPRS multi-slot class 10
- GPRS mobile station class B.

↳ DATA:

LTE:

- Downlink transfer: max. 150 Mbps
- Uplink transfer: max. 50 Mbps

HSPA:

- Downlink transfer: max. 7,2 Mbps
- Uplink transfer: max. 5,76 Mbps
-

GPRS:

- Downlink transfer: max. 85.6 kbps (see table 13)
- Uplink transfer: max. 42.8 kbps (see table 13)
- Coding scheme: CS-1, CS-2, CS-3 and CS-4.

CSD:

- CSD transmission rates: 2.4, 4.8, 9.6, 14.4 kbps, non-transparent, V.110.

↳ SMS:

- Text mode.

↳ Ring tones:

- Offers a choice of 19 different ringing tones/melodies, easily selectable with PFAL commands.

5.1.4. GNSS engine features

↪ GNSS engine:

- Multi channel GNSS (GPS + Galileo) receiver + (GLONASS optional)
- GPS L1 C/A code

↪ Accuracy:

- Position: 2.5 m CEP
- SBAS: 2 m CEP.

↪ Time to First Fix (TTFF):

- Hot starts: 1 sec.
- Cold starts: 26 sec.

↪ Sensitivity:

- Tracking: -161 dBm
- Cold start: -148 dBm.

↪ Operational limits:

- Velocity: 500 m/s (972 knots)
- Altitude: 50,000 m
- Max. update rate: 1 Hz.

↪ A-GPS support:

- AGPS: Online / Offline / Autonomous.

↪ Crystal oscillator (TCXO):

- Load sensitivity: $\pm 10\%$ load change, $0.2 \pm$ ppm.

5.2. NMEA data message

FOX3/-3G/-4G deliver data in the NMEA-0183 format and FALCOM own format. The table below lists the NMEA and FALCOM supported protocols and gives also a brief description for each of them. For further description about these protocols, refer to the related documents [1].

These protocols can be sent via SMS, TCP, data call, serial port, e-mail or stored inside the device using the corresponding PFAL-Commands. For example, the PFAL-Command "**PFAL,GSM.Send.TCP...**" allows sending the protocols via TCP to a remote server including the current device location, GPS state, UTC time, date, speed and course over ground. The received protocols by the server can then be used for graphically representation of the device location. Installing such a device in a vehicle, lets you know where your vehicle is, what is happening with your vehicle, has your vehicle been moved without authorization from a park area, updating vehicle movements in real time and more. The TCP server developed by FALCOM called "**Trace4You**" has a lot of such features allowing you to have a full control of your vehicle, fleet and your assets.

| NMEA | Description |
|--------|--|
| GPGLL | It contains GPS latitude, longitude, UTC time of position fix and status. |
| GPWGS | It contains satellites used in the GPS position solution and DOP values. |
| GPVTG | It contains the number of GPS satellites in view satellite ID numbers, elevation, azimuth and SNR values. |
| GPGLS | It contains the number of GPS satellites in view satellite ID numbers, elevation, azimuth and SNR values. |
| GPRMC | It contains GPS time, date, position, course and speed data. |
| GLGSA | It contains the GNSS DOP and Active Satellites (if GLONASS activated) |
| GLGSV | It contains the GNSS satellites in view (if GLONASS activated) |
| FALCOM | Description |
| GPIOP | It contains the status of digital/analog inputs and output ports and battery voltage (if battery available). |
| GP GSM | It contains the GSM operator, reception, registration status, GSM field strength, area code and cell ID. |
| GPAREA | It contains the state (entered or left the area/geofence) of 32 areas and 100 geofences - such as territory management, route verification, prohibited locations, parking area and more. |
| GP3DP | It contains the state values of the motion sensor. |
| BIN | The user protocol contains GPS time, date, position, course and speed data in binary format (small sized - only 21 characters). |

Table 5: NMEA Output Messages

6. FOX3/-3G/-4G APPLICATION INTERFACE

6.1. Power supply

The power supply for the FOX3/-3G/-4G devices has to be a single voltage source of $V_{+IN} = +10.8 \text{ V} \dots +32.0 \text{ V}$ DC. The operating voltage (V_{+IN}) has to be applied permanently to the FOX3/-3G/-4G devices and able to provide sufficient current of up to **1.5 A** (pulse).

The operating voltage (V_{+IN} and GND) is protected against voltage spikes and reverse polarity, but **NOT** protected against continuous overvoltage.

NOTE: Operating voltage range must never be exceeded; care must be taken in order to fulfill min/max voltage requirements.

6.1.1. Power supply pins (1 and 2) on the 8-pin connector

One +IN pin on the main 8-pin port is dedicated to connect the supply voltage, and the GND pin for grounding.

Both +IN and GND pins serve for charging the connected backup battery (option) and also for powering the FOX3/-3G/-4G devices. FOX3/-3G/-4G have an automatic power ON-function when external power is applied and no battery connected. The power supply for the FOX3/-3G/-4G ranges from $V_{+IN} = +10.8 \text{ V} \dots +32.0 \text{ VDC}$ allowing direct connection to vehicle power system.

| Signal name | I/O | Parameter | Description |
|-------------|-----|--|--|
| +IN | I | +10.8 V...+32.0 VDC. The operating voltage must never be exceeded. | Positive operating voltage. For security reason, it is recommended to protect the input voltage by an external 2A fuse between the device and d.c.-power source (see Fig 15). |
| GND | - | 0 V | Ground (should be isolated from the vehicle grounds when the device is going to be installed in a vehicle) |

6.1.2. Automatic shutdown

Automatic shutdown takes effect if:

- under voltage is detected (internal battery level runs below the nominal voltage and the external power supply is disconnected).

6.1.3. Power saving

SLEEP mode reduces the functionality of the modules of the FOX3/-3G/-4G devices to a minimum and, thus, minimizes the current consumption to the lowest level. The FOX3/-3G/-4G can be set into the sleep mode using the command `$PFAL, Sys.Device.Sleep=IGN+Ring+Timer=1:20:00` or with one or more parameters listed in the table below. Following SLEEP modes are supported by the FOX3/-3G/-4G devices:

| Modes | Description |
|-----------------|---|
| Example | <code>\$PFAL, Sys.Device.Sleep=IGN+Ring+Timer=1:20:00</code> <code>\$PFAL, Sys.Device.ChargeSleep=IGN</code> <code>\$PFAL, Sys.Device.Doze=Ign+Wakeup=23:20:00</code> |
| IGN | Device wakes-up when a rising edge (Low to High signal) on the IGN pin is detected. |
| Ring | Device wakes up on incoming voice call or SMS. |
| Wakeup=15:30:00 | Device wakes up at the set wake up time. |
| Timer=1:20:00 | Device wakes up when timeout has expired. |
| Motion=200 | Device wakes up when the set motion value is exceeded. |
| ExtPwrDetect | Device wakes up when external power connection is detected. |
| ExtPwrDrop | Device wakes up when external power disconnection is detected. For battery powered devices, the device wakes up when the battery voltage drops below the minimum. |
| GPS | Sets the GPS receiver into the Hibernate state |
| CAN | Device wakes up when activities on the CAN bus interface is detected. |
| LowBat=3.6 | Device wakes up when the battery voltage drops below the specified value |

IMPORTANT: The sleep and wake-up procedures are quite different depending on the selected sleep mode. Please note that the power saving with "Ring" works properly only when the PIN authentication has been done and the device is already registered in the GSM network. If you attempt to activate power saving while the device is not registered in the GSM network, the SIM card is not inserted or the PIN not correctly entered, the device responds error "ring shutdown aborted due to bad GSM coverage" and the power saving does not take place.

NOTE: *Related to the battery-powered devices only:*
When activating any sleep mode, make sure that the internal battery has enough power to safely wake up the device from that sleep mode. If the internal battery does not have enough power, the device can not complete the wake up process.

6.2. Determining the External Equipment Type

Before you connect the serial port pins of the FOX3/-3G/-4G devices to an external equipment, you need to determine if the external hardware serial ports are configured as DTE (*Data Terminal Equipment*) or DCE (*Data Communications Equipment*).

FOX3/-3G/-4G are designed for use as DCE devices. Based on the conventions for DCE-DTE connections, it communicates with the customer application (DTE) using the following signals:

| FOX3/-3G/-4G Terminal (DCE) | to | Application (DTE) |
|-----------------------------|--------|-------------------|
| RxA | <----- | TXD |
| TxA | -----> | RXD |
| GND | - | GND |

Table 6: The signaling definitions between DTE and DCE.

7. HARDWARE INTERFACES

This chapter describes the hardware interfaces:

| Interface specifications | |
|--------------------------|---|
| Main Port | The 8pin double-row connector, type: MOLEX-43045-08-MICRO FIT. It provides IN/OUT, power supply and first serial port (SER0) lines. The same pin functionality as FOX-IN/EN. |
| Accessory Port | The 6pin double-row connector, type: MOLEX-43045-06-MICRO FIT. It provides 1-Wire bus, I ² C master interface, second serial port (SER1). |
| 10pin-Mini-USB | 10pin mini-USB port with SPI interface and USB - Master interface. |
| Optical LED Indicators | 3 x LED indicators, free programmable using PFAL commands to show the device current state . |
| Mounting Holes | 4 x mounting holes for attaching the device to a suitable location (use M4x20 self tapping or machine screws for mounting, not included). |
| Audio interface | The audio connector has a diameter of 2.5 mm which allows to connect a SPK/MIC device to the FOX3/-3G/-4G. Hint: Only FOX3 and FOX3-3G-AUDIO have this connector and support audio for speaker and microphone. |
| External Antenna Ports | FAKRA connectors for connecting GSM & GNSS antennas. |
| Battery tray | It is used to insert and connect the battery to the device. |
| SIM Holder | It is used to insert your SIM card into the device for using GSM/GPRS services. |

Table 7: Interface specifications

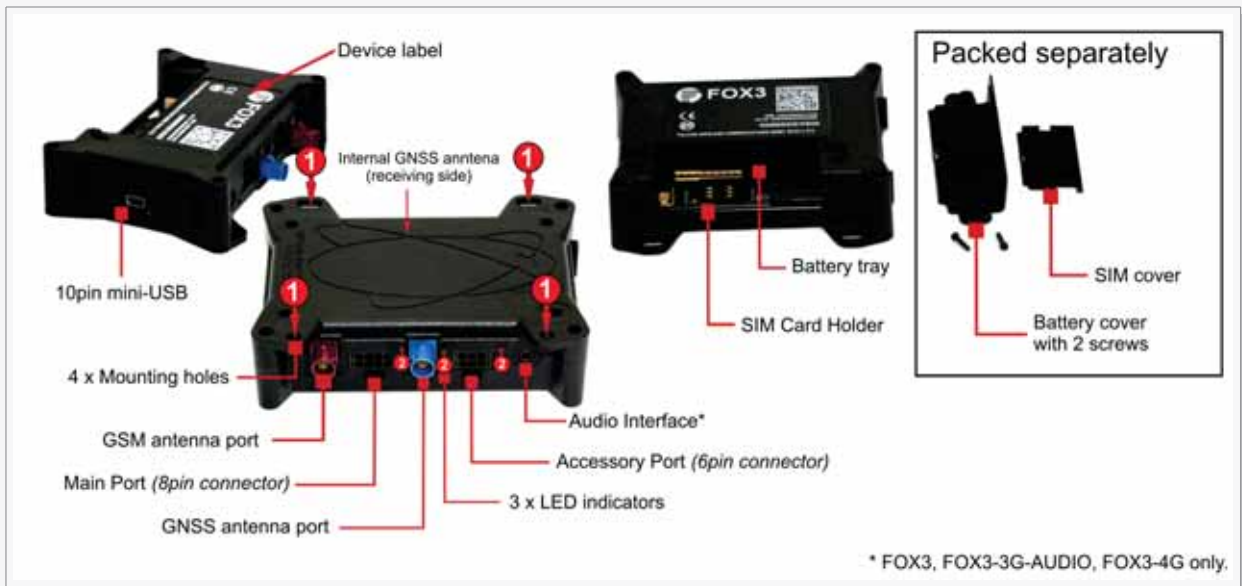

Figure 5: Interface specifications for FOX3/-3G/-4G devices.

7.1. Main Port (8pin connector)

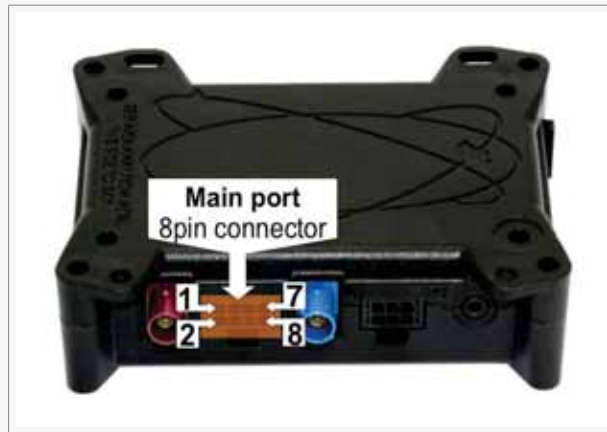

Figure 6: Pin assignments of 8-pin (2x4) connector (Type: MOLEX-43045-08-MICRO FIT)

7.1.1. Main Port Pinout

| PIN | NAM E | DIRECTION | DESCRIPTION | LEVEL |
|-----|-------|--------------|--|---|
| 1 | +IN | Input | Power supply input. The power supply must be able to meet the requirements of current consumption. Care must be taken so that the operating voltage, applied to the device, stay within the voltage range. Applying a voltage outside of the voltage range can damage the device. For security reason, it is recommended to integrate externally a 2A fuse link between power source and FOX3/-3G/-4G. | $V_{+IN} = + 10.8 \dots + 32.0 \text{ V}$ $I_{max} \leq 1.5 \text{ A}$ |
| 2 | GND | - | Ground. | 0 V |
| 3 | IGN | Input | General purpose input. It can be either connected to the vehicle ignition and be used for journey START and STOP reports, or be connected to the operating voltage +IN and be used to wakeup the FOX3/-3G/-4G devices from IGN-Sleep mode (<i>awaking from this mode requires a HIGH signal</i>). See also chapter 7.1.3.4. | HIGH $\geq +10.8 \dots +32.0 \text{ V DC}$; LOW = 0V |
| 4 | I/O1 | Input/Output | Software configurable pins. Each pin has dual functions as analog or digital. Each digital pin can individually be set either as input or output. | OUT : 100 mA max. @ +0 .. +32.0V DC |
| 5 | I/O2 | | Every time the device starts up, a level change occurs on the I/O2 and I/O3 pins. Only I/O1 doesn't change the level on device start up. | IN : 0 V..+32.0V DC (High & Low levels are free-programmable) |
| 6 | I/O3 | | Pins I/O2 and I/O3 support CAN communication if this interface is activated. The CAN-Bus interface can be activated using the corresponding PFAL command (see PFAL command set for more details). In this case the I/O2 = CAN_L and the I/O3 = CAN_H). | Analog : Up to 32.0 V DC/10 bits resolution |
| 7 | RxA_0 | Input | (Serial Port 0) The serial port (receive data) for direct connection to the host PC (for configuration, evaluation, firmware). If this pin is not used leave it open. | V24, $\pm 12 \text{ V}$ |
| 8 | TxA_0 | Output | (Serial Port 0) Serial port (transmit data) for direct connection to the host PC (for transmitting history data, output GPS protocols and more). If not used leave it open. | |

Table 8: Description of the main port (8-pin connector)

7.1.2. Installation cable (CA31-FOX3-KFZ-INST-1,5M-4x4)

This cable, which is NOT included in the standard delivery, is needed to install your FOX3/-3G/-4G to the vehicle. To order it, contact your vendor.

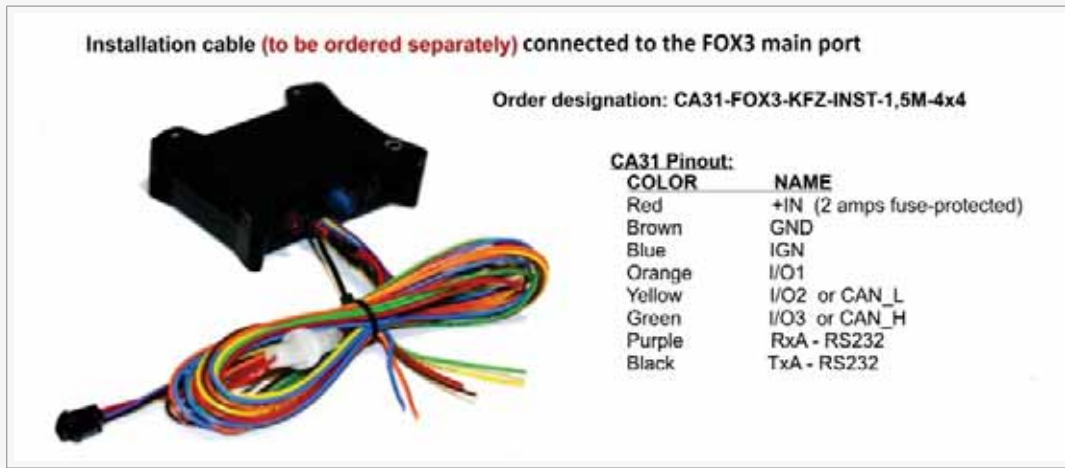

Figure 7: FOX3/-3G/-4G installation cable (KA70-FOX3-KFZ-INST-1,5M-2x4).

7.1.3. Special pin description (Pins 4, 5, 6)

The I/O2 and I/O3 (pin 5 and 6) can also operate as CAN-Bus interface if CAN is activated on the FOX3/-3G/-4G devices. More details about the CAN interface can be found in the PDF-files:

- 1) [AVL_PFAL_Configuration_Command_Set.pdf](#),
- 2) [AppNotesForCANBusApplication_xxx.pdf](#) and
- 3) [AppNote_CAN_FMS_CAN_OBDII_Howto_vxxx.pdf](#).

These pins have dual functions. All are controlled by the internal firmware of FOX3/-3G/-4G. Therefore, the user must define whether to use them as analog or digital pins. The configured digital pins can be inputs or outputs while the analog pins can only be inputs.

Their function is controlled by the command **PFAL,IO0[1,2].Config**. For example, if you want to use I/O1 as an analog pin, and the I/O2 and I/O3 as digital, then use the following commands respectively:

```
$PFAL,IO0.Config=AI,2,11 // 0 = I/O1; AI = analog; 2 and 11 = min. and max. voltages for Low and High events
$PFAL,IO1.Config=DI,5,10 // 1 = I/O2; DI = digital input; 5 and 10 = min. and max. voltages for Low and High events
$PFAL,IO2.Config=DI,5,10 // 2 = I/O3; DI = digital input; 5 and 10 = min. and max. voltages for Low and High events
```

If you want to use a digital pin, e.g. I/O2 or I/O3, as a digital output pin, then use the following PFAL command:

```
$PFAL,IO4.Set=high //4= I/O1; high = sets output to high
$PFAL,IO5.Set=high //5 = I/O2; high = sets output to high
$PFAL,IO6.Set=cyclic,2000,1000 //6 = I/O3; cyclic = sets output to high for 2 seconds and low for 1 seconds.
```

Some examples how to use them are given in the sections below.

When using an I/O as digital pin you must set it first to high (with PFAL command “\$PFAL,IO4.Set=high” or “\$PFAL,IO5.Set=high” or “\$PFAL,IO6.Set=high”), otherwise 0V will be measured (and the device could get damaged).

7.1.3.1. How to use I/O pins (4, 5, 6) as analog inputs

These pins can operate either as digital or analog inputs, however they should be configured and calibrated with PFAL commands for such purposes.

Analog voltages of up to 32.0V with a 10 bits resolution can be processed and remotely evaluated by a server application. A pull-up resistor to a constant input voltage allows for resistive transducers to ground, e.g. fuel sensor or thermistors.

To use these IOs as analog inputs, send the following command to the device.

\$PFAL,IO0[1,2].Config=AI,2,11

where 0, 1 and 2 are indices corresponding to IO1 (pin 4), IO2 (pin 5) and IO3 (pin 6), respectively. While the value 2 and 11 are min. and max. voltages that will be used to generate Low and High events, respectively. Detailed information can be found in the software manual "AVL_PFAL_Configuration_Command_Set.pdf".

Connection example 1 (for I/O1 and I/O2):

An analog input can be connected to a temperature sensor (a NTC resistor for instance). In the diagram below is used a fixed resistor from the input voltage to the I/O2, and a variable resistor (Negative Temperature Coefficient - whose resistance or capacitance decreases when temperature increases) to ground. It is possible to set a low temperature alarm and a high temperature alarm. Passage through these thresholds will trigger an alarm. We recommend to use SMS or TCP as alarm type with GPIOP protocol. The SMS can be received on a mobile phone, modem or any GSM device when changes are detected. The analog-to-digital converter (ADC) inside the unit has an input voltage range from 0 to 2.5 V. An application example is shown in figure below:

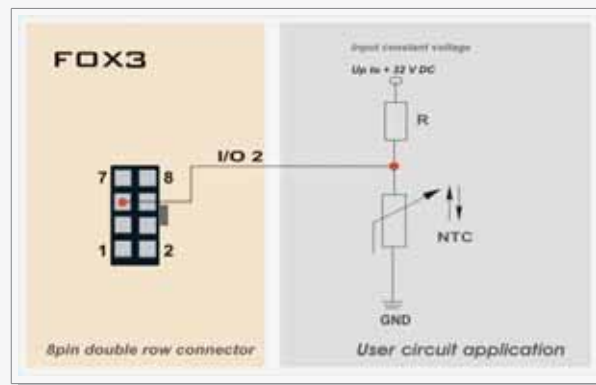

Figure 8: Connection example 1 when using it as analog input.

Connection example 2 (for I/O1 and I/O2):

An analog input can be connected to a tachometer generator. The maximum output voltage of the tachometer should be + 32.0 V (see illustrated example in figure below).

Both circuit examples (the NTC diagram above and the Tachometer below) are only illustrations to show the aim of these I/Os when using them as analog inputs.

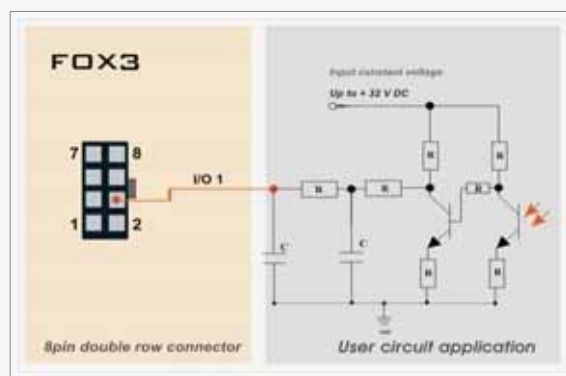

Figure 8.1: Connection example 2 when using it as analog input.

7.1.3.2. How to use I/O pins (4, 5, 6) as digital Inputs

These pins are high active when used as digital inputs, so you can set $V_{IN(Low)}$ and $V_{IN(High)}$ to any levels within the range from +0 to +32.0 VDC. The High and Low levels can be set with PFAL command (e.g.

PFAL,IO0[1,2].Config=DI,5,10) - where 0, 1 and 2 are indices corresponding to IO1 (pin 4), IO2 (pin 5) and IO3 (pin 6) respectively. The values 5 and 10 are min. and max. voltages that will be used to generate Low and High events respectively. Detailed information about PFAL commands can be found in software manual "AVL_PFAL_Configuration_Command_Set.pdf".

The figure below illustrates how these inputs can be used in practice. When the internal software detects input changes from *High* to *Low* or vice versa, a *Falling* or *Rising* edge Event is respectively generated. Therefore, depending on the alarm type, the FOX3/-3G/-4G can react to the input changes and release different alarms such as sending out SMS, email messages, TCP packets, opening a CSD connection or activating output ports. The alarm type is configuration-dependant.

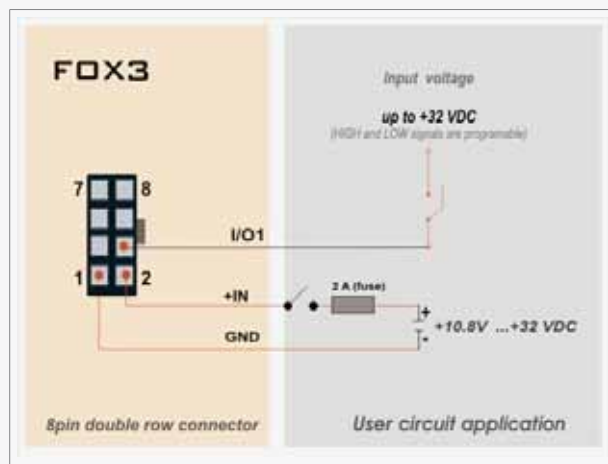

Figure 9: Connection example when using it as digital input.

A completed circuit example for all inputs is attached in section 10.1.1.

7.1.3.3. How to use I/O pins (4, 5, 6) as digital outputs

FOX3/-3G/-4G devices support three IOs which can be used either as input or output. These outputs are open collectors. They can be connected directly via resistors (R) to LEDs, Relays etc., which need no more power than *100 mA @ up to + 32.0 V DC*. The figures below show the schematic of possible output connections. To activate these outputs use the command **\$PFAL,IO4[5,6].Set=high[low,hpulse,lpulse,cyclic]** for **IO1**, **IO2** and **IO3** respectively or you can configure one or more alarms that activate these outputs when specific events occur (e.g. **\$PFAL,Cnf.Set,AL0=IO.e8=redge:IO4.Set=cyclic,1000,2000**).

In order to evaluate this alarm, send firstly this alarm configuration to the FOX3/-3G/-4G devices and then trigger IGN-pin to High – as result the IO1 goes High for 1 sec and Low for 2 sec. To set IO1 to Low, just execute the command **PFAL,IO4.Set=Low**. For more details how to activate an output and how to configure an alarm, refer to the manual "AVL_PFAL_Configuration_Command_Set.pdf". Both figures below show the schematic connections of how to use this output. **Please note that, the power should not be applied directly to an output pin without having e.g. a resistor between them.**

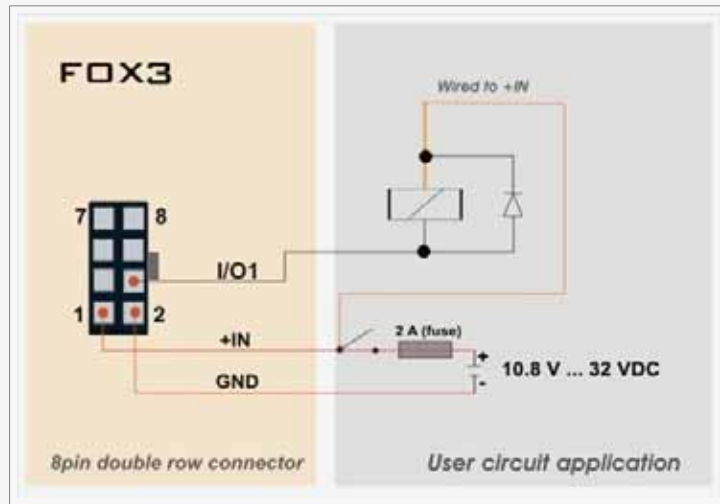

Figure 10: Connection example 1 when using it to control an Relay.

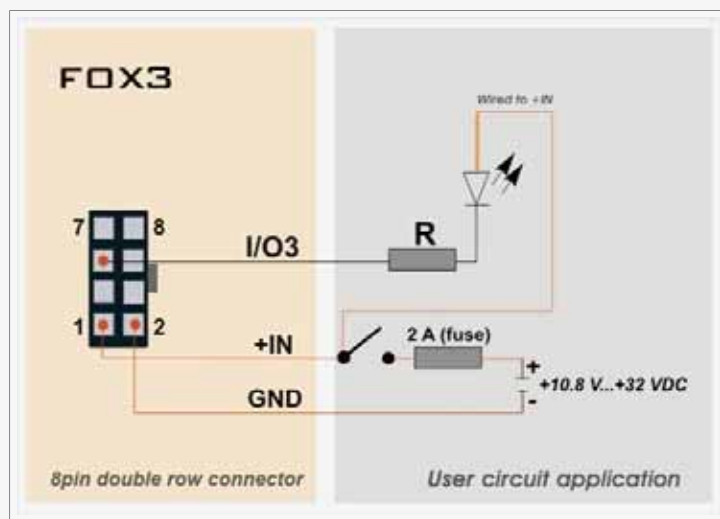

Figure 10.1: Connection example 2 when using it to control an LED.

7.1.3.4. How to use IGN pin (pin 3)

It is strongly recommended to connect this pin to the ignition key to support the IGN-power saving function when the vehicle is off.

The IGN-pin has two functions:

- ✓ It wakes up the system FOX3/-3G/-4G from the IGN-sleep mode (when sleeping),
- ✓ and can be used to monitor the vehicle ignition state, to report/store the trip START and STOP by using the events **IO.e8=redge** and **IO.e8=fedge** respectively.

IGN-sleep mode is one of the eight supported energy-saving modes of the device operation in which all unnecessary components are shut down. On IGN wake-up signal, the device returns to full functionality.

Note that, FOX3/-3G/-4G devices power on automatically when external power is applied, and IGN pin provides an additional "wake up" function for the IGN-sleep mode when it is requested.

In case of unauthorised vehicle access/start, you are automatically alarmed by SMS or TCP and the vehicle recovery can be started by knowing its exact location. In such a case, use the IGN generated event as a condition to start the vehicle tracking.

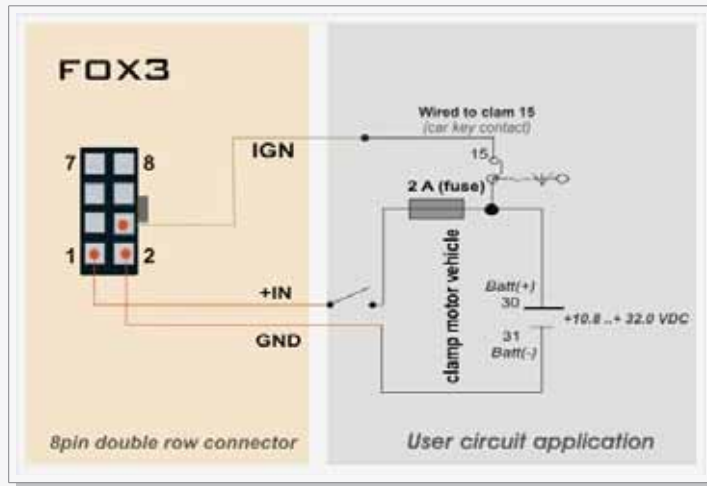

Figure 11: Monitoring vehicle starter by IGN line

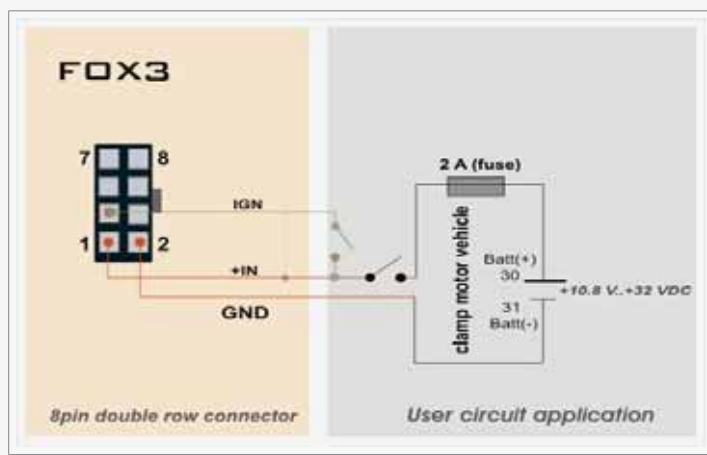

Figure 11.1: Use IGN line to wake FOX3/-3G/-4G up from IGN-Sleep

7.1.3.5. Serial Port 0 - Serial communication signals (RxA and TxA)

FOX3/-3G/-4G devices incorporates a full duplex serial channel which allows two devices to communicate directly with each other via the RS232 serial port. All supported variable baud rates are software-controlled. It is recommended to use the FOX3/-3G/-4G Evalboard in order to communicate with the FOX3/-3G/-4G devices, since you will find there all you need to evaluate with it. The signals on these pins are obtained to RS232 compatible signal levels.

RxA_0 Main channel used to receive software commands to the board from any software (e.g. HyperTerminal). Moreover, the firmware update can also be done through this serial port.

TxA_0 Main channel used to output navigation, measurement, response and system data to any software (e.g. HyperTerminal, FALCOM Workbench).

7.2. Accessory Port (6pin connector)



Figure 12: Pin assignments of 6-pin (2x3) connector (Type: MOLEX-43045-06-MICRO FIT)

7.2.1. Accessory Port Pinout

| PIN | NAME | DIRECTION | DESCRIPTION | LEVEL |
|-----|--------|---------------|---|-------------------------------------|
| 1 | 1-Wire | Input /Output | 1-Wire master interface for Driver ID, temperature and humidity sensors. | $V_{OUT} = + 2.8 .. +5.0 \text{ V}$ |
| 2 | GND | - | Ground Reference. | 0 V |
| 3 | RxA_1 | Input | (Serial Port 1) Serial port (receive data) for direct connection to the host PC (configuration, evaluation, firmware). If not used leave it open. | $V_{24}, \pm 12 \text{ V}$ |
| 4 | TxA_1 | Output | (Serial Port 1) Serial port (transmit data) for direct connection to the host PC (transmitting history data, output GPS protocols and others). If not used leave it open. | $V_{24}, \pm 12 \text{ V}$ |
| 5 | SCL | Output | I2C bus interface - Serial Clock line – the signal used to synchronize communication between the master and the slave. | |
| 6 | SDA | Input /Output | I2C bus interface - Serial Data line – the signal used to transfer data between the transmitter and the receiver. | |

Table 9: Description of the 6-pin (2x3) connector

7.2.2. 1-Wire interface description

A 1-Wire bus uses only one wire for signaling and power. One or several 1-Wire devices can be connected to the bus at the same time. Only one master should be connected to the bus.

Driver identification, temperature and humidity sensors are quite often used on vehicle applications. Thanks to the integration of 1-wire interface into the FOX3/-3G/-4G devices, the system integrators for telematics, fleet management and intelligent transportation system can be cost-benefit and time efficiently for their work due to the use of extra external devices which are not integrated in the in-vehicle computers. Using of the 1-Wire interface, you are able to know which drivers are in which vehicles and at the same time monitor the temperature and humidity of their refrigerated trucks. In this way, shippers can record by their server the transportation and the delivery state of their temperature-sensitive loads.

How does it work?

A 1-Wire network consists of a master controller which is connected to one or many slave devices. The 1-Wire interface on FOX3/-3G/-4G is a master controller. All of the actual monitoring devices (lightning detector, moisture meter, motion detector, barometer, etc.) are slave devices. FOX3/-3G/-4G communicate with temperature and iButton devices via 1-Wire protocol developed by Dallas Semiconductor, sending and

receiving signals over a single data line plus ground reference. The 1-Wire protocol synchronizes the monitoring devices to the FOX3/-3G/-4G. FOX3/-3G/-4G initiate and requests all activities on the 1-Wire network. One key feature of the Dallas system is that every 1-Wire slave device has a guaranteed unique address saved on-chip ROM (Read Only Memory). This enables the master to recognize individually each of your slave devices, and means you can have multiple devices of the same type on the same network without conflict.

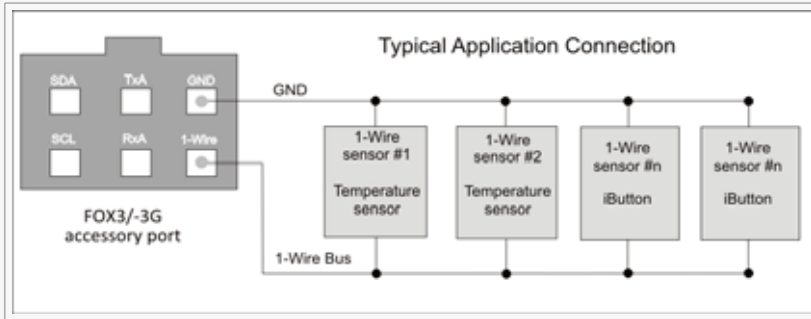

Figure 13: Typical application connection

Setting up a 1-Wire network with the FOX3/-3G/-4G devices is quite easy. 1-Wire is a simple system of devices such as temperature, iButton devices etc. that are connected through the 1-Wire data line plus ground reference to the FOX3/-3G/-4G devices. Remember that you can use and connect to the FOX3/-3G/-4G 1-Wire line only sensors that require power supply anywhere between 2.9V and 5.0V. FOX3/-3G/-4G devices receive on demand the unique address of the temperature and iButton IDs and other information they deliver. This information can then be sent via alarms to the remote TCP server.

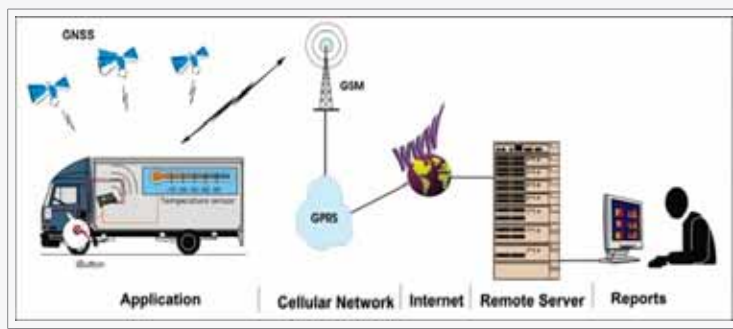

Figure 13.1: Typical application using 1-Wire single line.

More details about the 1-Wire interface, refer to the application note "*AppNote_1-Wire_Guide.pdf*", available in the FALCOMS's homepage: www.falcom.de.

7.2.2.1. Serial Port 1 - Serial communication signals (RxA_1 and TxA_1)

The FOX3/-3G/-4G devices incorporate a full duplex serial channel in the accessory port which allows two devices to communicate directly via RS232 serial ports. All supported baud rate are controlled by PFAL commands. In order to communicate with the FOX3/-3G/-4G devices, it is recommended to use the FOX3/-3G/-4G PromotionKit since you will find there all what you need for your evaluation. The signals on these pins are obtained to RS232 compatible signal levels.

| | |
|--------------|--|
| RxA_1 | Receive channel and can be used for executing commands and firmware update. |
| TxA_1 | Output channel for responses and system data to any software (e.g. HyperTerminal, FALCOM Workbench). |

7.3. Inserting a SIM card into the SIM holder

FOX3/-3G/-4G devices have a GSM modem that requires a SIM card to access to the mobile network services. The SIM card is obtained from your mobile provider and must be activated for GSM data services before using it. Together with the SIM card, you receive a 4-digit PIN number. Entering of the PIN allows your device to access the mobile network.

To insert the SIM card into the FOX3/-3G/-4G' SIM holder, follow the steps below:

- 1) Remove the power supply and any other connections from the device. Turn the FOX3/-3G/-4G devices on their back side as shown in the figure 14 below.
- 2) Indicate the SIM card holder on the left of the battery try **(1)**. To open it, push the metal slider in direction marked "⇒ **OPEN**".
- 3) Flip the card holder up **(2)**.
- 4) Insert the SIM card **(3)** into the card holder in direction as shown in the figure below.
- 5) Flip the card-holder back (without force) **(4)**, then hold it pressed and move the metal slider in direction marked "⇐ **LOCK**" until it stops.
- 6) Insert the SIM card cover in the direction as shown in picture below **(5)** and slide it until it stops.
- 7) If you have already ordered a backup battery to connect it to the FOX3/-3G/-4G (e.g. B1 - 1000 mAh battery, see figure 14.1 below), just plug in the 3pin connector of the battery cable to the battery connector on the left side in the battery tray (FOX3/-3G/-4G PCB).
- 8) Finally, place the battery cover and then screw it with both screws and a T6-TORX screwdriver **(6)**.

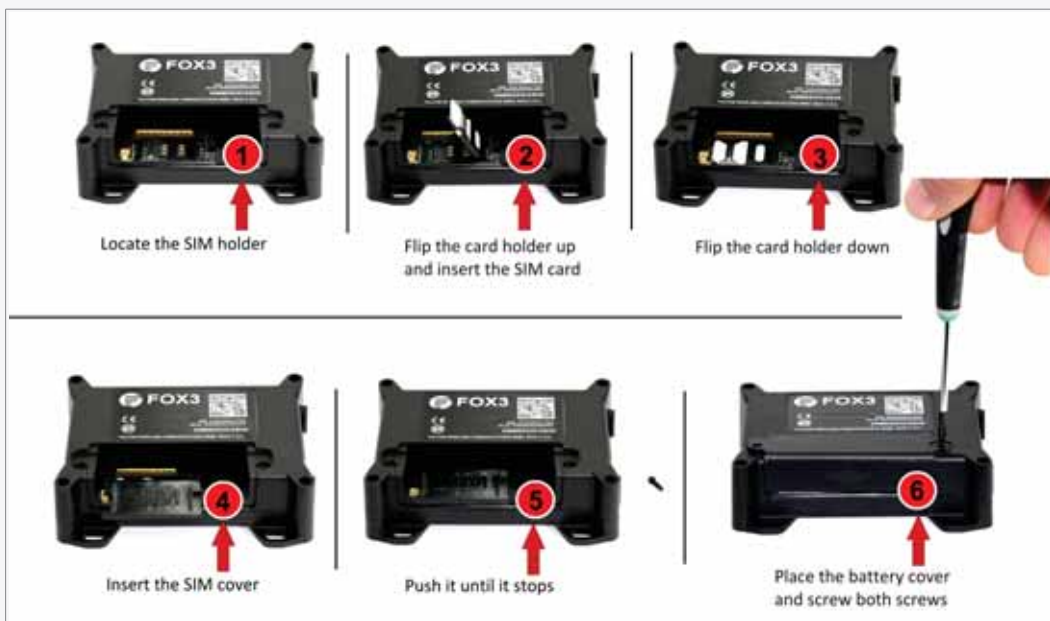

Figure 14: Steps for inserting the SIM card into FOX3/-3G/-4G devices



Figure 14.1: Connecting the battery to the FOX3/-3G/-4G devices

7.3.1. How to enter the PIN of the inserted SIM card

To insert the PIN of the SIM card follow the steps below (as reference use fig. 15):

- 1) Install the **FALCOM Workbench** software,
- 2) Connect your FOX3/-3G/-4G to a free PC COM port via its Promotion Kit and power up your device. **How to set up your FOX3/-3G/-4G using a Evalboard, is currently in preparation.**
- 3) Start the **FALCOM Workbench** software, open a **COM Port (1)**, a **Terminal (2)** and an **Editor (3)**, then select the COM port **(4)** and port settings (115200 bps, 8 Data bits, No Parity bit, 1 Stop bit, None Flow control).
- 4) Next, click on the **Connect** icon (II) on the left of the text "**Port**", to connect to. Connect the **Console (5)** to the **COM Port** and the **Editor (6)** to the **Console** on the **Connection view**. For more details refer to the Workbench User's Guide.
- 5) Finally, type the command `$PFAL,Cnf.Set,GSM.PIN=xxxx` on the the editor (xxxx=PIN of your SIM card) and then send it to the device by double-click. For more details refer to the manual "*AVL_PFAL_Configuration_Command_Set.pdf*".

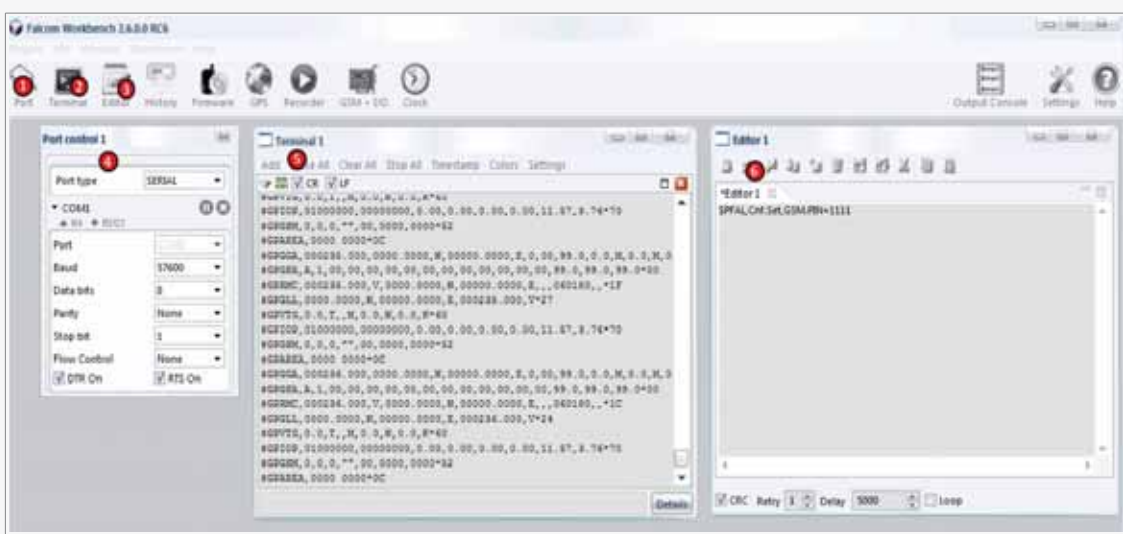

Figure 15: Entering the PIN code of the inserted SIM card.

7.4. LED indicators

The actual state of the FOX3/-3G/-4G can be displayed by three LED's on the front panel of the unit. These programmable and accessible LEDs can be interfaced to the build-in components to show their state. References how to customize the device configuration can be found in the FOX3/-3G/-4G software manual "AVL_PFAL_Configuration_Command_Set.pdf".

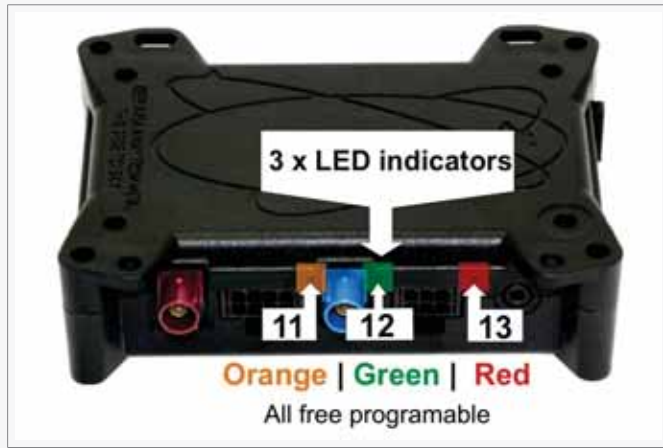

Figure 16: View of LED indicators

To turn on one of these LEDs, use the following command:

```
$PFAL,IO11.Set=high           // 11=LED Orange;
$PFAL,IO12.Set=hpulse,2000    // 12=LED Green;
$PFAL,IO13.Set=cyclic,2000,1000 // 13=LED Red;
```

To turn off these LEDs, use the following command with corresponding index number:

```
$PFAL,IO[11,12,13].Set=low
```

7.5. 10pin mini-USB port

This port supports a SPI and a USB 2.0 interface. The following table gives you an overview about the provided pins on this 10pin mini-USB-port.



Figure 17: Pin assignments of the 10pin mini-USB port.

This table shows the pinout of 10pin mini-USB connector.

| PIN | NAME | DIRECTION | DESCRIPTION | LEVEL |
|-----|------------|----------------|--|--|
| 1 | MOSI | Output | Master output, slave input | |
| 2 | USB_V+ | Input / Output | Power supply for IO-BOX | + 3.6 ... + 5.25 V |
| 3 | MISO | Input | Master input, slave output | |
| 4 | DM | Input | USB Data - | Complies to the USB 2.0 specifications |
| 5 | CLK | Output | Serial clock | |
| 6 | DP | Output | USB Data + | Complies to the USB 2.0 specifications |
| 7 | Detect USB | | Detects the connection to a USB master port. | |
| 8 | +IN | Input | =+IN (Pin 1 on 8pin connector) | $V_{+IN} = + 10.8 \dots + 32.0 \text{ V}$; $I_{max} \leq 1\text{A}$ |
| 9 | CS | Output | Chip select | |
| 10 | GND | - | Ground | |

Table 10: Pin description of the 10pin mini-USB.

This port can be used to connect the FOX3/-3G/-4G to the IOBOX-MINI device, which is offered as an accessory to the FOX3/-3G/-4G device.

7.5.1. Setting up a USB connection for FOX3/-3G/-4G

To setup a USB connection with FOX3/-3G/-4G, do the following steps:

1. Download the USB driver free of charge from the FALCOM's website "[FOX3_CDC_driver.zip](https://www.falcom.de/uploads/media/FOX3_CDC_driver.zip)". Please login first then click the link below to download the driver (https://www.falcom.de/uploads/media/FOX3_CDC_driver.zip)
2. Connect the FOX3/-3G/-4G to a free USB port on your PC via your own mini-USB to USB cable and install the driver. How to install the CDC driver refer to the sub-chapter below.
3. Open a terminal program and send the command \$PFAL,MSG.Send.USB,0,"Speed=&(Speed)" from the serial port (e.g. Serial 1/0) to the FOX3/-3G/-4G. The answer to this command will be shown on the terminal program where FOX3/-3G/-4G is connected to.

7.5.1.1. Installing the CDC driver files for FOX3/-3G/-4G

To install the FOX3/-3G/-4G CDC driver, do the following steps:

1. After downloading the driver from the FALCOM's website "[FOX3_CDC_driver.zip](https://www.falcom.de/uploads/media/FOX3_CDC_driver.zip)". Unzip the contents to a separate folder.
2. Connect the FOX3/-3G/-4G to your PC. You will see a message pop up that installation failed.
3. Right-click the popup, and choose "Browse my computer for Driver Software",

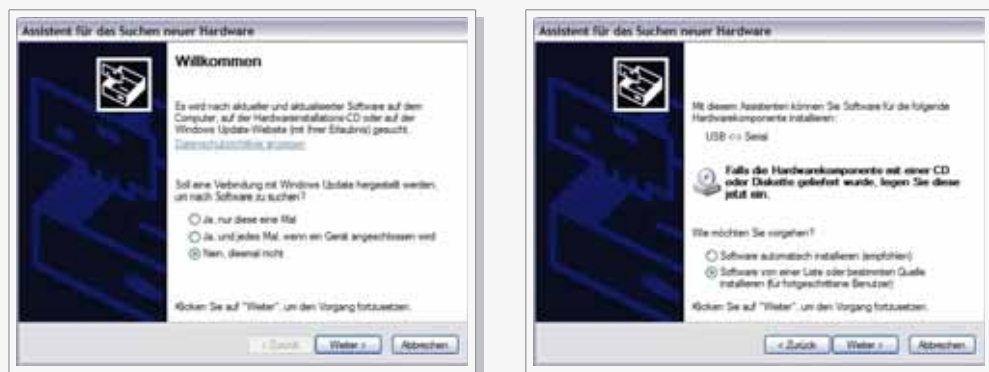

Figure 18: Search for USB drivers for FOX3/-3G/-4G hardware.

- In the Browse window, navigate to the folder where you extracted the contents of the Zip driver file. Please note that a double (manual) driver installation is required. In the ZIP file of the FOX3/-3G/-4G USB driver you can find the file: "*mambo2cdc.inf*"



Figure 19: Navigate to the USB CDC driver folder.

- Follow the remaining prompts and Windows will install the driver.



Figure 20: Installing the USB drivers.

- To find the COM port assigned to the FOX3, open Device Manager, go to "Connections" (as shown in figure below).

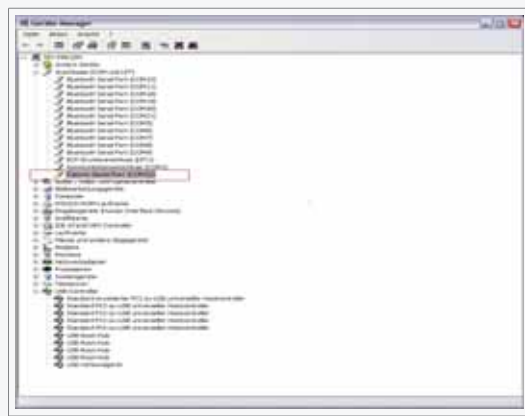

Figure 21: Search for the assigned Falcom serial port number.

- After installation is complete, you can delete the files you downloaded. Windows will reuse the installed driver information for any future FOX3/-3G/-4G devices.
- To communicate with FOX3/-3G/-4G via the USB port, use a Terminal program and select the USB serial port number assigned by the Windows to the installed USB driver in the Device Manager.

7.5.2. IOBOX-MINI/CAN accessory devices for FOX3/-3G/-4G

7.5.2.1. Connecting IOBOX-MINI/CAN to FOX3/-3G/-4G

Requirements for mounting the IOBOX-MINI/CAN to the FOX3/-3G/-4G devices:

- T6-TORX screwdriver

To mount the IOBOX-MINI or IOBOX-CAN to one of the FOX3/-3G/-4G devices, follow next steps:

1. Remove the power supply and any other connections from the device. Use a T6-TORX screwdriver as shown in step (1) and unscrew 4 screws as shown in step (2).
2. Open the casing of the device as shown in step (3).
3. Indicate the USB connector on the device PCB and plug in the IOBOX-MINI or IOBOX-CAN to it as shown in steps (4) and (5).
4. Hold pressed the front of the IOBOX-MINI or IOBOX-CAN as shown in step (6) and place the lower case on to the upper case of the device. Insert carefully the two tabs of the IOBOX-MINI or IOBOX-CAN into the two slots of the lower case of the device (6) and then slide the lower case until it stops (7).
5. Close the device with all 4 screws (8). Make sure that both cases fit to each other and there is no space between them.



Figure 22: Mounting IOBOX-MINI or IOBOX-CAN to the FOX3/-3G/-4G devices.

7.5.2.2. IOBOX-MINI pinout

The IOBOX-MINI is offered for the FOX3/-3G/-4G as an accessory for input/output extensions. To connect external input/output ports to the IOBOX-MINI, you have to order **CA38** - 16pin cable.



FOX3/-3G/-4G with IOBOX-MINI plugged in

IOBOX-MINI assignment

Figure 23: IOBOX-MINI pinout.

This table shows the pinout of IOBOX-MINI.

| PIN | NAME | I/O | DESCRIPTION | LEVEL |
|-----|------|-----|---|-------------------------------------|
| 1 | GND | - | Ground. | 0 V |
| 2 | IN5 | I | Digital input. | 0 .. +32.0 V DC ($V_{+IN} = +IN$) |
| 3 | - | - | No function | - |
| 4 | IN6 | I | Digital input. | 0 .. +32.0 V DC ($V_{+IN} = +IN$) |
| 5 | - | - | No function | - |
| 6 | IN7 | I | Digital input. | 0 .. +32.0 V DC ($V_{+IN} = +IN$) |
| 7 | ANA | I | Analogue input with 10 bits resolution. | 0 .. +32.0V DC |
| 8 | IN0 | I | Digital input. | 0 .. +32.0 V DC ($V_{+IN} = +IN$) |
| 9 | OUT0 | O | Open collector output. | 100 mA max. @ 0 .. +32.0V DC |
| 10 | IN1 | I | Digital input. | 0 .. +32.0 V DC ($V_{+IN} = +IN$) |
| 11 | OUT1 | O | Open collector output. | 100 mA max. @ 0 .. +32.0V DC |
| 12 | IN2 | I | Digital input. | 0 .. +32.0 V DC ($V_{+IN} = +IN$) |
| 13 | OUT3 | O | Open collector output. | 100 mA max. @ 0 .. +32.0V DC |
| 14 | IN3 | I | Digital input. | 0 .. +32.0 V DC ($V_{+IN} = +IN$) |
| 15 | OUT2 | O | Open collector output. | 100 mA max. @ 0 .. +32.0V DC |
| 16 | IN4 | I | Digital input. | 0 .. +32.0 V DC ($V_{+IN} = +IN$) |

Table 11: IOBOX-MINI pinout

The indices of these inputs and outputs can be found in the manual "AVL_PFAL_Configuration_Command_Set.pdf".

7.5.2.3. IOBOX-CAN pinout

The IOBOX-CAN is offered for the FOX3/-3G/-4G as an accessory for using a second CAN Bus interface (known in the firmware as CANB interface) and to extend the input/output ports on the FOX3/-3G/-4G. To connect external input/output ports to the IOBOX-CAN and use also second CAN Bus features, you have to order **CA38** - 16pin cable.



FOX3/-3G/-4G with IOBOX-CAN plugged in

IOBOX-CAN assignment

Figure 24: IOBOX-CAN pinout.

This table shows the pinout of IOBOX-CAN.

| PIN | NAME | I/O | DESCRIPTION | Main function | Alternative function | LEVEL |
|-----|---------|-----|-------------------------|----------------------------|----------------------|--|
| 1 | V5CAN | O | Power Supply Output | - | - | Vout = 5V DC ; I _{max} ≤ 50mA |
| 2 | IN1 | I | Digital/Analogue input | Analogue 10-bit resolution | Digital | 0 V DC .. +52.0 V DC |
| 3 | GND | - | Ground | | | 0 V |
| 4 | IN2 | I | Digital/Analogue input | Analogue 10-bit resolution | Digital | 0 V DC .. +52.0 V DC |
| 5 | OUT1 | O | Open collector output | Output | - | 100 mA max. @ 0 .. +32.0V DC |
| 6 | IN3 | I | Digital/Analogue input | Analogue 10-bit resolution | Digital | 0 V DC .. +52.0 V DC |
| 7 | OUT2 | O | Open collector output | Output | - | 100 mA max. @ 0 .. +32.0V DC |
| 8 | IN4 | I | Digital/Analogue input | Analogue 10-bit resolution | Digital | 0 V DC .. +52.0 V DC |
| 9 | OUT3 | O | Open collector output | Output | - | 100 mA max. @ 0 .. +32.0V DC |
| 10 | CAN_H | I/O | CAN HIGH-level | - | - | - |
| 11 | OUT4 | O | Open collector output | Output | - | 100 mA max. @ 0 .. +32.0V DC |
| 12 | CAN_L | I/O | CAN LOW-level | - | - | - |
| 13 | K-LINE | I/O | Currently not supported | - | - | - |
| 14 | L-LINE | O | Currently not supported | - | - | - |
| 15 | VCAN | I | Currently not used | - | - | |
| 16 | GND_CAN | - | Ground | - | - | 0 V |

Table 12: IOBOX-CAN pinout

The indices of these inputs and outputs and information how to use this CAN interface can be found in the manual "AVL_PFAL_Configuration_Command_Set.pdf" and "AppNote_CAN_FMS_CAN_OBDII_Howto.pdf".

7.6. Mounting

FOX3/-3G/-4G offer different mounting possibilities, depending on the kind of the antenna used.

1. When installing one of FOX3/-3G/-4G with internal antennas, please make sure the FOX3/-3G/-4G' back side with the text "THIS SIDE TO SKY" is facing up to the sky, with no metal objects above or under the device case that can interfere with GPS reception.
2. When installing a FOX3/-3G/-4G with external antennas, there are two connectors on the device for connecting a GPS/GNSS antenna such as FAL-ANT-11 (shown in figure below) or FAL-ANT-12 from FALCOM. During the installation, please make sure the receiving side of the GSM/GPS antenna is up, with no metal object above or under the antenna and device that interfere with GPS reception.

Each of FOX3/-3G/-4G provide 8 holes to be attached to suitable locations (see figure below). It can be mounted in different directions and different locations such as on wall or in vehicle. Fasteners can be Hexagon head with collar self drilling screws DIN 7504 K, ST3.5 x 32(12) mm and different length. **There are no screws included in the delivery pack.** More detailed information how to install the device in the vehicle, refer to the application note "[AppNotes_AVL_Installation_Guide.pdf](#)".

FOX3/-3G/-4G are NOT waterproof or sealed devices. Care must be taken to ensure the devices are kept away from water or any other liquids.

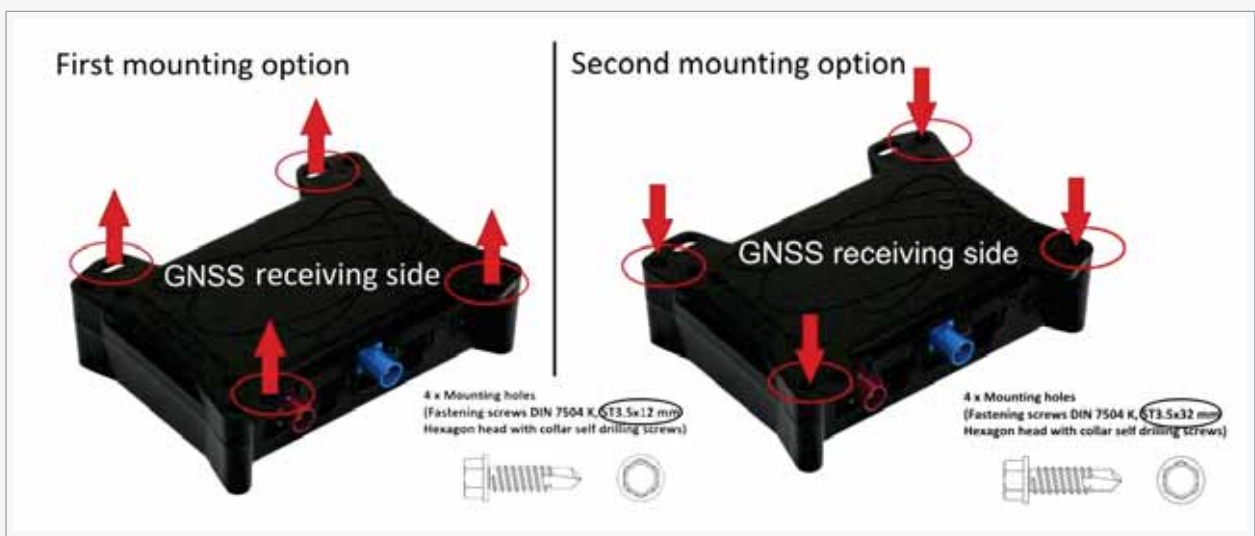

Figure 25: View of the mounting holes

7.6.1. External Antenna Ports

FOX3/-3G/-4G are fitted with two male *SMB FAKRA* connectors that accept a wide variety of GSM/GNSS antenna styles for using external antennas instead of the internal ones. The **Bordeaux** connector (*see figure below*) is for connecting a GSM antenna. The **Blue** connector (*see figure below*) is for connecting a GNSS antenna. **There is no antenna included in the standard delivery, it needs to be ordered separately.**

FALCOM provides two combined *GSM/GNNS* antenna (FAL-ANT11) especially, for the FOX3, STEPIII, FOX-EN and the 2G/3G/4G GNNS antenna (FAL-ANT-14) for FOX3-3G/-4G devices. FAL-ANT-11 operates on four frequencies: 850/900/1800/1900 MHz. FAL-ANT-14 is a penta-band and operates on five frequencies: 850/900/1800/1900 MHz, WCDMA 2100MHz. The GNNS antenna operates on 1575.42 MHz frequency. The combined GSM/ GNNS antennas should be ordered by FALCOM, the order names are: **FAL-ANT-11, FAL-ANT-14**. Any other GPS antenna connected to the FOX3/-3G/-4G devices must draw less than 25 mA. The antenna voltage is supplied internally. The figure below shows how to connect these antennas.

For more details about the FAL-ANT-11 and FAL-ANT-14, refer to the data sheet "*FAL-ANT-11_Datasheet.pdf*" available on the Falcom web page.



Figure 26: GSM/GPS antenna ports

CAUTION : Be careful not to accidental swap the GSM and GPS connectors. The device will not function if the antennas are swapped.

In order to comply with RF exposure requirements, install the antenna so that a distance minimum of 20 cm can be maintained between the antenna and persons.

To connect the **FAL-ANT-11** or **FAL-ANT-14** combined GSM/GPS antenna to the FOX3 or FOX3-3G/-4G devices:

- ✓ Plug the **Bordeaux**-coloured connector of the antenna to the **Bordeaux** coloured connector of the device.
- ✓ Plug the **Blue**-coloured connector of the antenna to the **Blue** coloured connector of the device.

To remove the **FAL-ANT-11** or **FAL-ANT-14** GSM/GPS antenna from the FOX3 or FOX3-3G/-4G devices:

- ✓ Press down the latches on the antenna connectors and then pull the antennas.

Do not mount the antenna visible on the dashboard but mount it in a location underneath the dashboard. Hiding the antenna is key to successful security in the event of theft. FOX3/-3G/-4G devices generate events in case of the GNNS antenna is connected, disconnected or cut off. If an intruder cuts off the GNNS antenna cable, an event is generated which can be used to trigger alarm notifications to the user.

7.7. Audio Interface

FOX3 and FOX3-3G-AUDIO devices have a 2.5 mm audio female 4pin connector for connecting an external active SPK/MIC device. If you are going to connect a loudspeaker directly to the FOX3 or FOX3-3G-AUDIO, FALCOM highly recommended that the cable of the loudspeaker or the loudspeaker itself is galvanic isolated from the audio channel of the FOX3 and FOX3-3G-AUDIO. This ensures a properly operation of the loudspeaker.

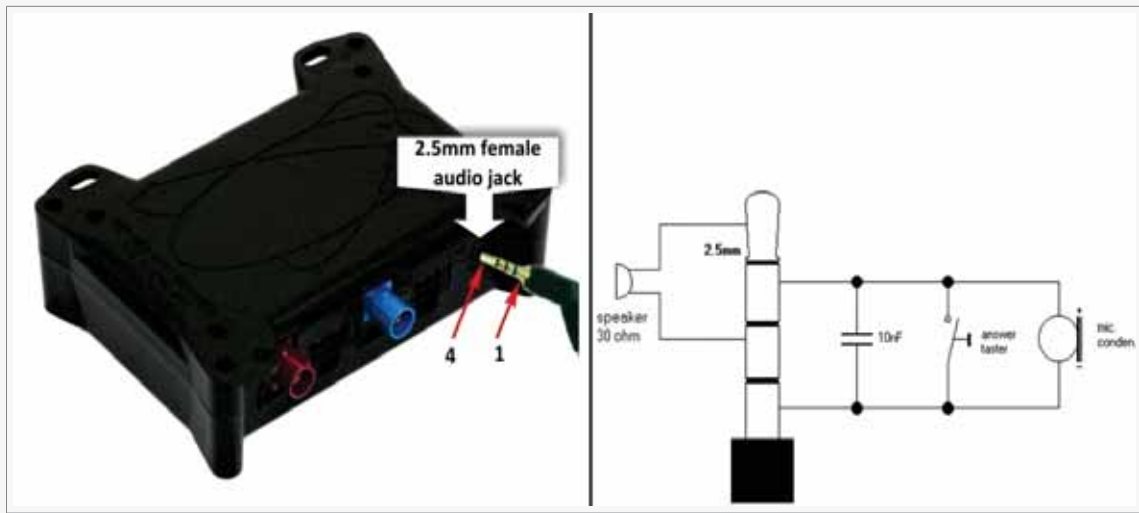

Figure 27: Audio plug 4pin connector

To know the pinout of the audio jack on the FOX3/-3G-AUDIO, see table below.

| Pin | Pin name | Description | Pin | Pin name | Description |
|-----|----------|---------------------|-----|----------|--------------------|
| 1 | MIC | Mic - | 3 | MIC | Mic + |
| 2 | R_SPKR | Right audio speaker | 4 | L_SPKR | Left audio speaker |

The following table lists some typical electret microphone electrical and speaker characteristics when connecting them directly to the FOX3 and FOX3-3G-AUDIO audio interfaces:

| | |
|-------------------|---|
| Microphone | The microphone should be a electret condenser microphone @ 2.2 k. |
| Speaker | The speaker should be a passive headset with 80 ohm or a active speaker with symmetric balanced input. Asymmetric non balanced input will cause GSM noise in the speaker. |

FALCOM provides an adapter cable (called "CA81b") with an integrated transformer that provides a full galvanic isolation between the FOX3/-3G-AUDIO audio interfaces and your loudspeaker. It allows connection to any loudspeaker on the market. If you would like to use this audio adapter cable, then you need to order it using the order designation "CA81b".

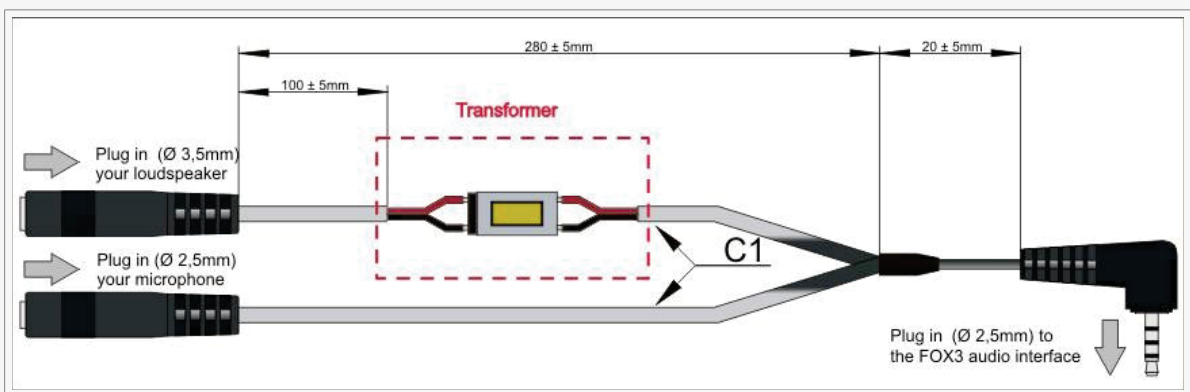

Figure 27.1: CA81b - Audio cable with integrated transformer provided by FALCOM

8. HOUSING

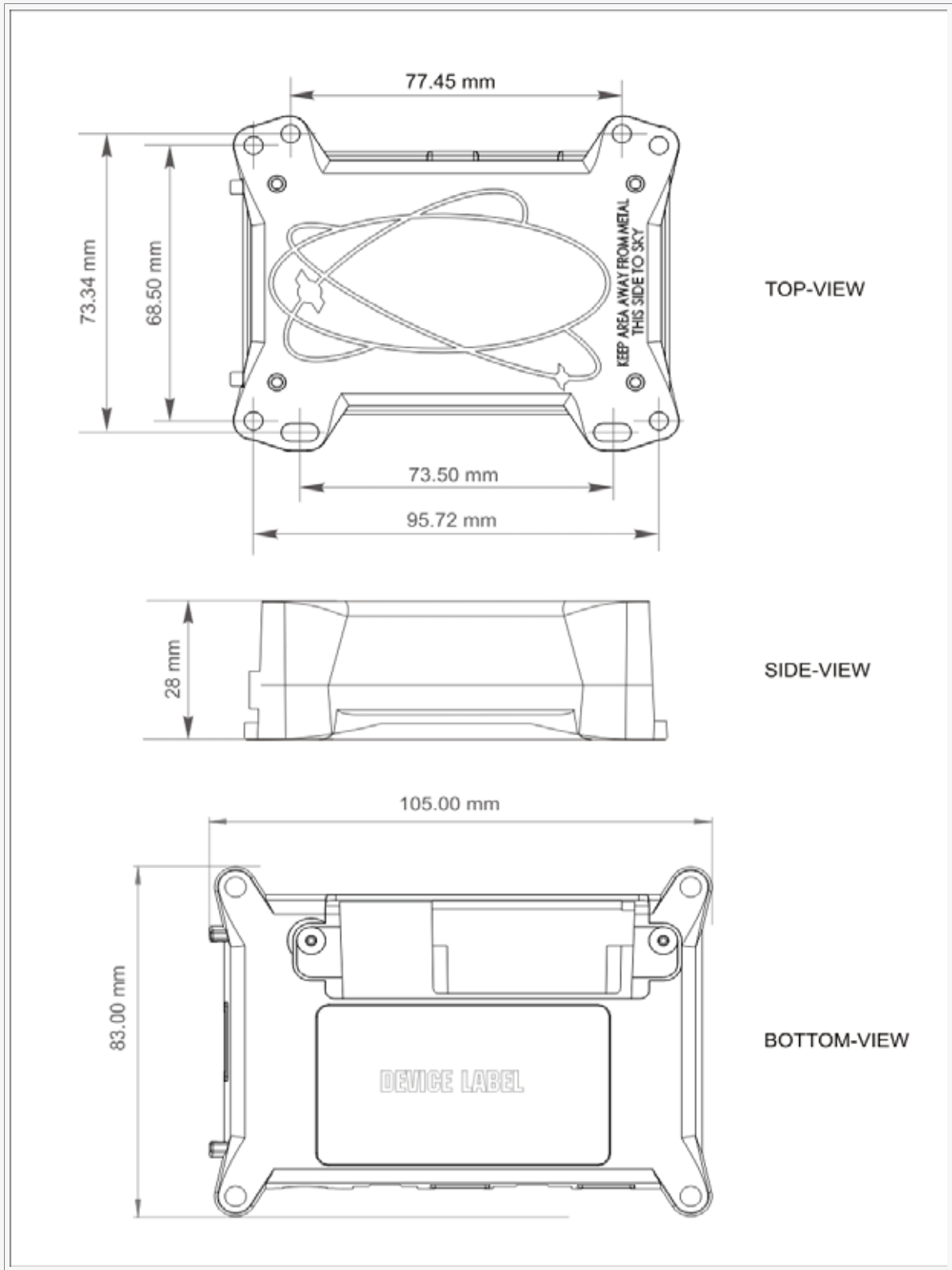

Figure 28: FOX3/-3G/-4G housing

9. RF EXPOSURES

9.1. RF Exposures - English

This device contains 850/900/1800/1900 MHz GSM/GPRS functions, 850/900/1700/1900/ 2100 MHz UMTS functions and Band 2, 4, 5, 7, 17 LTE functions and is operational in these frequencies respectively.

Following frequency bands are not operational (must not be used) in U.S. Territories.

- GSM: 900/1800 MHz
- UMTS: 2100/1700 MHz
- LTE: Band 7 (2600 MHz).

The external antennas used for this mobile transmitter must provide a separation distance of at least 20 cm from all persons and must not be co-located or operating in conjunction with any other antenna or transmitter.

Statement according to FCC part 15.19:

This device complies with Part 15 of the FCC Rules. Operation is subject to the following two conditions:

- this device may not cause harmful interference, and
- this device must accept any interference received, including interference that may cause undesired operation.

Statement according to FCC part 15.21:

Modifications not expressly approved by this company could void the user's authority to operate the equipment.

Statement according to FCC part 15.105:

NOTE: This equipment has been tested and found to comply with the limits for a Class B digital device, pursuant to Part 15 of the FCC Rules. These limits are designed to provide reasonable protection against harmful interference in a residential installation. This equipment generates, uses and can radiate radio frequency energy and, if not installed and used in accordance with the instructions, may cause harmful interference to radio communications.

However, there is no guarantee that interference will not occur in a particular installation. If this equipment does cause harmful interference to radio or television reception, which can be determined by turning the equipment off and on, the user is encouraged to try to correct the interference by one or more of the following measures:

- Reorient or relocate the receiving antenna.
- Increase the separation between the equipment and receiver.
- Connect the equipment into an outlet on a circuit different from that to which the receiver is connected.
- Consult the dealer or an experienced radio/TV technician for help.

9.2. Exposition RF - French

Cet appareil contient des fonctions 850/900/1800/1900 MHz GSM/GPRS, 800/850/900/ 1900/2100 MHz UMTS et bandes 2, 4, 5, 7, 17 LTE et est opérationnel dans ces fréquences, respectivement.

Les bandes de fréquences suivantes ne sont pas opérationnelles (ne doivent pas être utilisés) dans le territoire fédéral américain:

- GSM: 900/1800 MHz
- UMTS: 2100/1700 MHz
- LTE: bande 7 (2600 MHz).

L'antenne externe utilisé pour ce transmetteur mobile doit être placée à une distance d'au moins 20 cms de toute personne et ne doit pas être placée ou manié en combinaison avec nulle autre antenne ou transmetteur.

Déclaration en accord avec FCC partie 15.19:

Cet appareil satisfait aux règles de la FCC, partie 15. La mise en service est sujette aux deux conditions suivantes:

- cet appareil ne doit pas causer d'interférences préjudiciables et
- cet appareil doit accepter toute interférence reçue, interférences, qui peuvent causer des actions indésirés, incluses.

Déclaration en accord avec FCC partie 15.21:

Des modifications n'ayant pas été expressément approuvé par cette société, pourraient annuler l'autorisation de l'utilisateur d'opérer cet équipement.

Déclaration en accord avec FCC partie 15.105:

NOTE: Cet équipement a été testé et satisfait aux limites d'un appareil digital, classe B, en accord avec la partie 15 des règles de la FCC. Ces limitations sont déterminés pour assurer une protection raisonnable contre les interférences préjudiciables lors d'une installation résidentielle. Cet appareil génère, utilise et peut répandre de l'énergie radiofréquence et, s'il n'est pas installé et utilisé en accord avec les instructions, peut causer des interférences préjudiciables à la radiocommunication.

Cependant, il n'y a pas de garantie que des interférences n'auront pas lieu dans une installation particulière. Si l'équipement pose des interférences préjudiciables à la réception radio ou télévision, ce qui peut être déterminé en allumant et éteignant l'équipement, l'utilisateur est encouragé à essayer de rectifier les interférences par l'une ou l'autre des mesures suivantes:

- Réorientez ou relocalisez l'antenne réceptrice.
- Augmentez la distance entre l'équipement et le récepteur.
- Connectez l'équipement à une prise dans un circuit différent de celui auquel le récepteur est connecté.
- Consultez votre revendeur ou un technicien radio/télévision expérimenté pour du support.

10. APPENDIX

10.1. Schematics

The figure below illustrates a common schematic of how to install the FOX3/-3G/-4G devices in the vehicle. For detailed information, refer to the related documents [[AppNotes_AVL_Installation_Guide.pdf](#)].

10.1.1. Installation guidance

When installing the FOX3/-3G/-4G in a vehicle, you will be able to track and locate the vehicle all the time and also you will be automatically notified when disagreements with your stored configuration into the FOX3/-3G/-4G device are occurred. Depending on the user requirements, the operator may program the digital outputs to activate something e.g. a relay, buzzer, turn on a lamp, etc. The digital inputs can individually be configured e.g. to detect something when it is opened or closed; changes on digital inputs may trigger an output to activate, for example, a relay or buzzer. The IGN line can be connected to the vehicle ignition key to monitor its ON/OFF position.

Note: Turn the car ignition off before making any connection. Use a common ground point for all device ground pins. To avoid ground loops and second grounds, isolate all grounded pins of the FOX3/-3G/-4G from the vehicle body. Do not connect power from a different system to the FOX3/-3G/-4G.

The outputs of the FOX3/-3G/-4G devices must be supplied with the same voltage applied to the (+IN) pin. The operating voltage MUST never exceed its range, due to the device is not protected again continuous overvoltage. For security reasons, it is recommended to integrate an external 2A fuse between the positive wire of the FOX3/-3G/-4G (+IN) and d.c. - power source.

When using an external antenna, be sure to mount it on the dash or on the windshield of the vehicle with the GPS side facing the sky.

Apply power to the FOX3/-3G/-4G devices only with external antenna connected (if used) and vehicle ignition off. First, connect the GND pin and finally, apply power to the +IN pin of the FOX3/-3G/-4G.

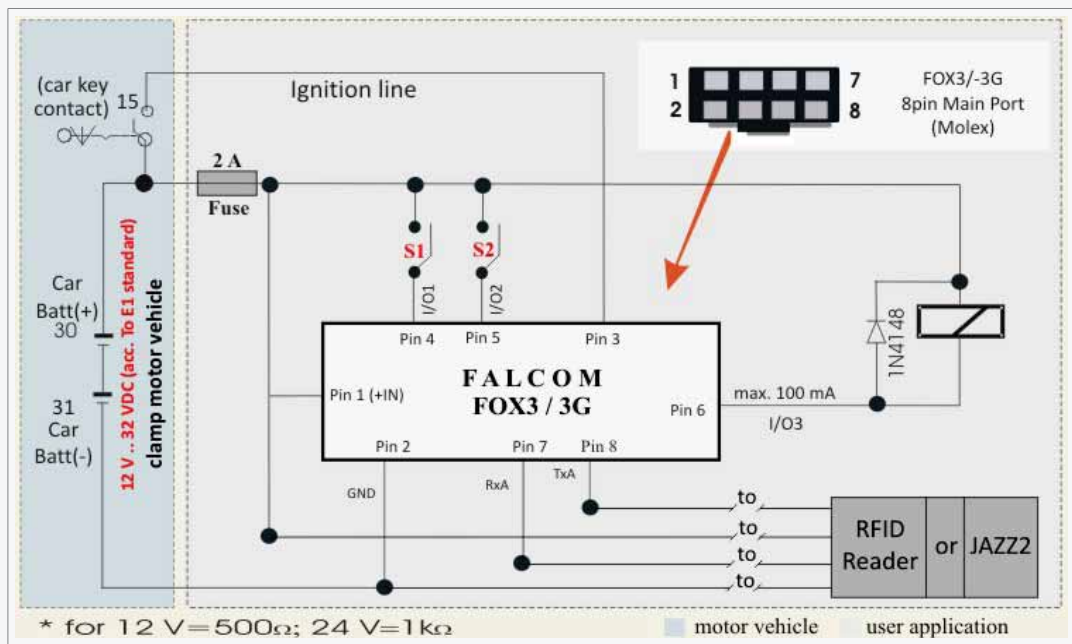

Figure 29: Schematic example of installation guidance.

10.2. What should be considered when using FOX3/-3G/-4G device

FOX3/-3G/-4G are devices controlled by means of the PFAL commands which are developed by FALCOM. These PFAL commands can be executed when the operating firmware inside the device is running. In order to create application with the FOX3/-3G/-4G device and to obtain maximum benefit from the FOX3/-3G/-4G operating firmware, you have to setup a specific configuration and store it in the device. All PFAL commands can be sent to the FOX3/-3G/-4G with the help of the Workbench software, which is free of charge and can be downloaded from the FALCOM's website (<http://www.falcom.de>). All PFAL commands supported by the FOX3/-3G/-4G and other AVL devices are listed and described in a separate manual called "AVL_PFAL_Configuration_Command_Set.pdf" which is accessible online at the FALCOM website under the password-protected area.

10.3. GPRS Coding scheme

| Coding scheme | 1 Timeslot | 2 Timeslots | 4 Timeslots |
|---------------|------------|-------------|-------------|
| CS-1: | 9.05 kbps | 18.1 kbps | 36.2 kbps |
| CS-2: | 13.4 kbps | 26.8 kbps | 53.6 kbps |
| CS-3: | 15.6 kbps | 31.2 kbps | 62.4 kbps |
| CS-4: | 21.4 kbps | 42.8 kbps | 85.6 kbps |

Table 13: Coding schemes and maximum net data rates over air interface

Please note that, the values listed above are the maximum ratings which, in practice, are influenced by a great variety of factors, primarily, for example, traffic variations and network coverage.