

# STEPP II

## Hardware description



**Index of contents**

**0 INTRODUCTION ..... 4**

0.1 GENERAL ..... 4

0.2 CIRCUIT CONCEPT ..... 5

0.3 SCOPE OF DELIVERY ..... 6

0.4 USED ABBREVIATIONS ..... 6

0.5 RELATED DOCUMENTS ..... 7

**1 SECURITY ..... 8**

1.1 GENERAL INFORMATION ..... 8

1.2 EXPOSURE TO RF ENERGY ..... 8

1.3 EFFICIENT MODEM OPERATION ..... 8

1.4 ANTENNA CARE AND REPLACEMENT ..... 9

1.5 DRIVING ..... 9

1.6 ELECTRONIC DEVICES ..... 9

1.7 VEHICLE ELECTRONIC EQUIPMENT ..... 9

1.8 MEDICAL ELECTRONIC EQUIPMENT ..... 9

1.9 AIRCRAFT ..... 9

1.10 CHILDREN ..... 10

1.11 BLASTING AREAS ..... 10

1.12 POTENTIALLY EXPLOSIVE ATMOSPHERES ..... 10

1.13 NON-IONIZING RADIATION ..... 10

**2 SAFETY STANDARDS ..... 11**

**3 TECHNICAL DATA ..... 12**

3.1 GENERAL SPECIFICATIONS OF TERMINAL STEPP II ..... 12

3.1.1 Power consumption ..... 13

3.1.2 Operating temperatures ..... 13

3.2 TECHNICAL SPECIFICATIONS OF GSM/GPRS ENGINE\* ..... 14

3.2.1 Air interface of the STEPP II GSM/GPRS part ..... 16

3.3 TECHNICAL SPECIFICATIONS OF GPS RECEIVER ..... 16

3.4 NMEA DATA MESSAGE ..... 17

**4 FUNCTIONAL DESCRIPTION ..... 19**

4.1 HOW DOES IT WORKS ..... 19

4.2 FALCOM STEPP II TYPICAL APPLICATIONS ..... 21

**5 STEPP II APPLICATION INTERFACE ..... 23**

5.1 POWER SUPPLY ..... 23

5.1.1 Power up/down scenarios ..... 23

5.1.2 Power supply pins (14, 15 and 16) on the 16-pin connector ..... 23

5.1.3 Automatic shutdown ..... 24

5.1.3.1 *Over voltage shutdown* ..... 24

5.2 AUTOMATIC GPRS MULTISLOT CLASS CHANGE ..... 24

5.3 DETERMINING THE EXTERNAL EQUIPMENT TYPE ..... 24

**6 HARDWARE INTERFACES ..... 26**

6.1 INTERFACE A (16-PIN MOLEX 43045-1609) ..... 27

6.1.1 Description of the 16-pin connector ..... 27

6.1.2 Special pin description ..... 28

6.1.2.1 *Analog inputs (pin 2, 4)* ..... 28

6.1.2.2 *Inputs (pin 6, 8, 10, 12)* ..... 29

6.1.2.3 *Outputs (pin 5, 7, 9, 11)* ..... 30

6.1.2.4 *VBAT (pin 14)* ..... 30

6.1.2.5 *Ignition (pin 13)* ..... 32

6.2 INTERFACE B (SIM CARD INTERFACE MOLEX-91228-0002)..... 33

6.3 INTERFACES C AND D..... 34

6.4 INTERFACE E (AMP 558556-1 CONNECTOR)..... 34

6.4.1 The 15- pin connector description ..... 35

6.4.2 Special pin description..... 35

6.4.2.1 VC 5 ..... 35

6.4.2.2 Boot select ..... 36

6.4.2.3 Serial communication signals (RxA, TxA)..... 36

6.4.2.4 Speaker outputs characteristics..... 36

6.5 INTERFACE F (LED'S DESCRIPTION) ..... 36

6.5.1 Interface E (Mounting holes)..... 37

6.5.1.1 Mounting the cradle to the terminal ..... 38

6.5.1.2 Placing the terminal ..... 38

**7 HOUSING .....39**

**8 STEPP II-MOUNTING CRADLE.....40**

**9 RF EXPOSURES.....41**

**10 APPENDIX .....42**

10.1 SCHEMATICS..... 42

10.1.1 Installation guidance for 16-pin Molex connector ..... 42

10.1.2 Installation guidance for 15-pin AMP connector..... 43

Version history:

Version number	Author	Changes
1.00	Fadil Beqiri	Initial release
1.01	Fadil Beqiri	- Description improved. - Some images changed.

## **Cautions**

Information furnished herein by FALCOM are accurate and reliable. However, no responsibility is assumed for its use.

Please, read carefully the safety precautions.

If you have any technical questions regarding this document or the product described in it, please contact your vendor.

General information about FALCOM and its range of products are available at the following internet address: <http://www.falcom.de/>

## **Trademarks**

Some mentioned products are registered trademarks of their respective companies.

## **Copyright**

The STEPP II user's guide is copyrighted by FALCOM GmbH with all rights reserved. No part of this user's guide may be produced in any form without the prior written permission of FALCOM GmbH.

## **FALCOM GmbH.**

No patent liability is assumed with respect to the use of the information contained herein.

## 0 Introduction

### 0.1 General

This description is focused on the GSM/GPRS and GPS terminal STEPP II from FALCOM GmbH. It contains information about purpose and use of the STEPP II concept.

In order quickly to start and immediately and comprehensive to use all functions and to avoid any mistakes of STEPP II terminal on your utilization, we recommend to read the following references and suggestions for using your new STEPP II terminal.

The STEPP II is a Plug-and-Play device which provides a powerful state-of-the-art technologies (GSM, GPS, internet) and makes them available for quick and easy integration into a number of applications for the vertical and horizontal market. The new STEPP II concept is a Full Type Approved combined GSM/GPRS/GPS Smart Terminal.

The compact design of the GSM/GPRS/GSM STEPP II terminal integrates it in an all-in-one solution. This combination concept and internal embedded software (known as firmware) make it available to be used in a wide range of tracking solutions such as fleet management, vehicle tracking, navigation, emergency calling, location-based services and many others.

The STEPP II is designed to be used on any GSM network. This single compact device is Tri-band GSM/GPRS engine that works on the three frequencies GSM 900MHz, GSM 1800 MHz and GSM 1900 MHz, it supports also state-of-art GPS technology for satellite navigation.

The embedded firmware based on the eCos operating system for the TCP/IP communication protocol (TCP/IP stack) converts data streams into data packets and makes GPRS traffic possible for industrial and automotive applications. No PDA or laptop needed for establishing a GPRS connection, it has its own TCP/IP and PPP stack and will work as a stand-alone terminal. STEPP II features GPRS multislots class 10 and supports the GPRS coding schemes CS-1, CS-2, CS-3 and CS-4. The STEPP II terminal can send and receive data by GSM and GPRS networks. It supports SMS, data and voice calls as well as internet and e-mail. The STEPP II terminal can be easily controlled by using SMS and PRSF commands provided on the embedded software for all kinds of operations.

The internal advanced GPS system uses twelve parallel channels, providing highly accurate positional, speed, time and date information. Using satellite signals the embedded GPS module enables users to determine the position of device anywhere in the world. The STEPP II module has an integrated TCXO which also improves the GPS system performance. Due to the temperature-stabilizing its position is determined more precisely.

A compact "stacked FLASH/SRAM" device stores the STEPP II software in the FLASH memory section of terminal, and a static RAM section provides the additional storage capacity required by GPRS connectivity.

Regarding the internal temperature of system, a built-in active cooling & heating system improves significantly system performance. Due to this electronic component, the STEPP II device is capable to operate in range from  $-40^{\circ}\text{C}$  to  $+85^{\circ}\text{C}$ . This component controls automatically the current

temperature of the terminal. It activates or deactivates the heating/cooling process to keep the internal temperature of STEPP II terminal under the required range for a normal operation.

The physical interfaces to the terminal application are made through integrated connectors. These are required for controlling the unit, receiving GPS location data, transferring data and audio signals and providing power supply lines. STEPP II provides a serial interface (2-wire and GND on the 16-pin AMP connector) giving you maximum flexibility for locally use.

The STEPP II contains an intelligent on-board charging management compatible with Li-Ion batteries. Lines are wired to the 16-pin connector which enable a direct connection to a Li-Ion battery.

Figure 1 shows the front and back side of the STEPP II.



Figure 1: Front and back side of STEPP II

## 0.2 Circuit concept

The STEPP II architecture includes the following major functional components (see figure 2):

- ❖ architecture integrates:
  - ✓ high-performance Dual Band GSM/GPRS core
  - ✓ 12 parallel channel low-power GPS core
  - ✓ ARM7TDMI processor that controls all functions of the system
  - ✓ Power Control circuitry for Li-Ion backup batteries
  - ✓ Cooling/Heating system
  - ✓ Audio amplifier
  - ✓ Interface circuitry
- ❖ physical interfaces:
  - ✓ 16-pin Molex connector (Type: Molex 43045-1609, and counterpart: Casing: 43025-1600 and Box type spring contact: 43031-0001) for power supply and I/O's
  - ✓ 15-pin AMP connector (Type: AMP5-558556-1, and counterpart: 558666-1) for audio interfaces and software update
  - ✓ SIM Card reader (Type: Molex-91228-0002 small SIM Card)

- ✓ GSM antenna interface (Type: Connector 50 Ω Fakra/Radiall SMB-male)
- ✓ GPS antenna interface (Type: Connector 50 Ω Fakra/Radiall SMB-male)

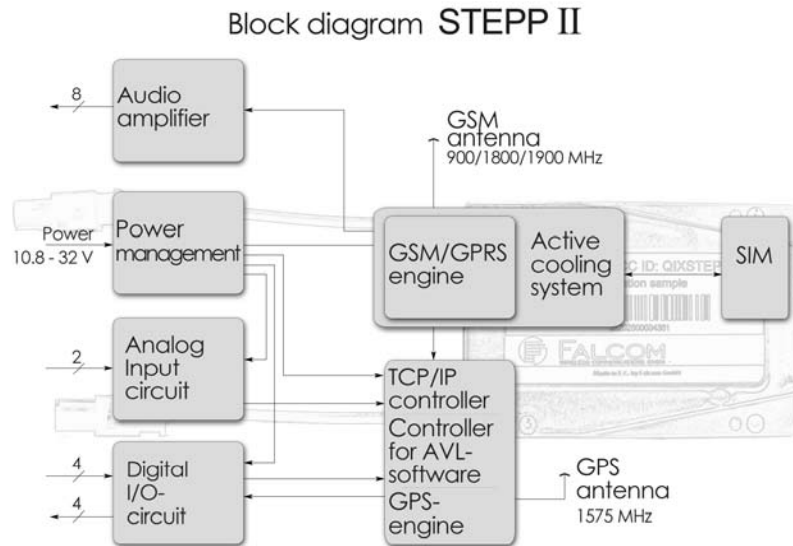

Figure 2: Architecture of the STEPP II terminal

### 0.3 Scope of delivery

Check the contents of the package. In case of damaged or missing any item, please contact your dealer immediately.

Concerning the STEPP II, there are two different terminals which operate in the different frequencies:

1. **STEPP-II-55** is a Tri-band device which operates in the three frequencies GSM 900 MHz, DCS 1800 MHz and PCS 1900 MHz, and is available to use in the European and Asia Networks.
2. **STEPP-II-56** is a Tri-band device which operates in the three frequencies GSM 850 MHz, DCS 1800 MHz and PCS 1900 MHz, and is available to use in the American Networks.

Regarding the electrical interfaces, mechanical specification (dimension, form etc.) and electrical specification they are the same to both terminals.

Please, note that according to your requirements you can choose the desired STEPP II device.

### 0.4 Used abbreviations

Abbreviation	Description
ASIC	Application Specific Integrated Circuit
DOP	Dilution of Precision
GPS	Global Positioning System
GSM	Global Standard for Mobile Communications
GGA	GPS Fixed Data
HDOP	Horizontal DOP

Abbreviation	Description
HW	Hardware
IMEI	International Mobile Equipment Identity
I/O	Input/Output
NMEA	National Marine Electronics Association
PRN	Pseudorandom Noise Number – The Identity of GPS satellites
RF	Radio Frequency
RTC	Real Time Clock
RXQUAL	Received Signal Quality
SIM	Subscriber Identification Module
SMS	Short Message Service
SRAM	Static Random Access Memory
TA	Terminal Adapter
TE	Terminal Equipment
TP	Transmit Protocol
TTF	Time to First Fix
SA	Selective Availability
WAAS	Wide Area Augmentation System
MSK	Minimum Shift Keying

Table 1: Used abbreviations

## 0.5 Related documents

1. ETSI GSM 07.05:“Use of Data Terminal Equipment–Data Circuit terminating Equipment interface for Short Message Service and Cell Broadcast Service”
2. ETSI GSM 07.07“AT command set for GSM Mobile Equipment”
3. ITU-T V.25ter “Serial asynchronous automatic dialing and control”
4. SiRF binary and NMEA protocol specification;  
[www.falcom.de/Service/Manuals/SiRF](http://www.falcom.de/Service/Manuals/SiRF)
5. stepp\_II\_getting\_started.pdf
6. stepp\_II\_software\_2.0RC1\_manual.pdf
7. stepp\_II\_software\_1.6.2\_manual.pdf
8. falcom\_eCos\_SDK\_user\_guide.pdf



## 1 Security

IMPORTANT FOR THE EFFICIENT AND SAFE OPERATION OF YOUR GSM-MODEM, READ THIS INFORMATION BEFORE USE!

Your cellular engine STEPP II is one of the most exciting and innovative electronic products ever developed. With it you can stay in contact with your office, your home, emergency services and others, wherever service is provided.

This chapter contains important information for the safe and reliable use of the STEPP II. Please read this chapter carefully before starting to use the cellular engine STEPP II.

### 1.1 General information

Your STEPP II device utilizes the GSM/GPRS/GPS standard for cellular technology. GSM/GPRS is a newer radio frequency („RF“) technology than the current FM technology that has been used for radio communications for decades. The GSM standard has been established for use in the European community and elsewhere. Your modem is actually a low power radio transmitter and receiver. It sends out and receives radio frequency energy. When you use your modem, the cellular system handling your calls controls both the radio frequency and the power level of your cellular modem.

### 1.2 Exposure to RF energy

There has been some public concern about possible health effects of using GSM modem. Although research on health effects from RF energy has focused for many years on the current RF technology, scientists have begun research regarding newer radio technologies, such as GSM. After existing research had been reviewed, and after compliance to all applicable safety standards had been tested, it has been concluded that the product is fit for use.

If you are concerned about exposure to RF energy there are things you can do to minimize exposure. Obviously, limiting the duration of your calls will reduce your exposure to RF energy. In addition, you can reduce RF exposure by operating your cellular modem efficiently by following the guidelines below.

### 1.3 Efficient modem operation

In order to operate your modem at the lowest power level, consistent with satisfactory call quality please take note of the following hints.

- If your modem has an extendible antenna, extend it fully. Some models allow you to place a call with the antenna retracted. However, your modem operates more efficiently with the antenna fully extended.
- Do not hold the antenna when the modem is „IN USE“. Holding the antenna affects call quality and may cause the modem to operate at a higher power level than needed.

## **1.4 Antenna care and replacement**

Do not use the modem with a damaged antenna. If a damaged antenna comes into contact with the skin, a minor burn may result. Replace a damaged antenna immediately. Consult your manual to see if you may change the antenna yourself. If so, use only a manufacturer-approved antenna. Otherwise, have your antenna repaired by a qualified technician.

Use only the supplied or approved antenna. Unauthorized antennas, modifications or attachments could damage the modem and may contravene local RF emission regulations or invalidate type approval.

## **1.5 Driving**

Check the laws and regulations on the use of cellular devices in the area where you drive. Always obey them. Also, when using your modem while driving, please pay full attention to driving, pull off the road and park before making or answering a call if driving conditions so require. When applications are prepared for mobile use they should fulfill road-safety instructions of the current law!

## **1.6 Electronic devices**

Most electronic equipment, for example in hospitals and motor vehicles is shielded from RF energy. However, RF energy may affect some malfunctioning or improperly shielded electronic equipment.

## **1.7 Vehicle electronic equipment**

Check your vehicle manufacturer's representative to determine if any on board electronic equipment is adequately shielded from RF energy.

## **1.8 Medical electronic equipment**

Consult the manufacturer of any personal medical devices (such as pacemakers, hearing aids, etc.) to determine if they are adequately shielded from external RF energy.

Turn your STEPP II device OFF in health care facilities when any regulations posted in the area instruct you to do so. Hospitals or health care facilities may be using RF monitoring equipment.

## **1.9 Aircraft**

Turn your STEPP II OFF before boarding any aircraft.

Use it on the ground only with crew permission.

Do not use it in the air.

To prevent possible interference with aircraft systems, Federal Aviation Administration (FAA) regulations require you to have permission from a crew member to use your modem while the plane is on the ground. To prevent interference with cellular systems, local RF regulations prohibit using your modem whilst airborne.

## 1.10 Children

Do not allow children to play with your STEPP II device. It is not a toy. Children could hurt themselves or others (by poking themselves or others in the eye with the antenna, for example). Children could damage the modem or make calls that increase your modem bills.

## 1.11 Blasting areas

To avoid interfering with blasting operations, turn your unit OFF when in a “blasting area” or in areas posted: „turn off two-way radio“. Construction crew often use remote control RF devices to set off explosives.

## 1.12 Potentially explosive atmospheres

Turn your STEPP II device **OFF** when in any area with a potentially explosive atmosphere. It is rare, but your modem or its accessories could generate sparks. Sparks in such areas could cause an explosion or fire resulting in bodily injury or even death.

Areas with a potentially explosive atmosphere are often, but not always, clearly marked. They include fuelling areas such as petrol stations; below decks on boats; fuel or chemical transfer or storage facilities; and areas where the air contains chemicals or particles, such as grain, dust or metal powders.

Do not transport or store flammable gas, liquid or explosives, in the compartment of your vehicle which contains your modem or accessories.

Before using your modem in a vehicle powered by liquefied petroleum gas (such as propane or butane) ensure that the vehicle complies with the relevant fire and safety regulations of the country in which the vehicle is to be used.

## 1.13 Non-ionizing radiation

As with other mobile radio transmitting equipment users are advised that for satisfactory operation and for the safety of personnel, it is recommended that no part of the human body be allowed to come too close to the antenna during operation of the equipment.

The radio equipment shall be connected to the antenna via a non-radiating 50 Ohm coaxial cable.

The antenna shall be mounted in such a position that no part of the human body will normally rest close to any part of the antenna. It is also recommended to use the equipment not close to medical devices as for example hearing aids and pacemakers.

## 2 Safety standards

This GSM/GPS modem complies with all applicable RF safety standards. The embedded GSM/GPRS/GPS modem meets the safety standards for RF receivers and the standards and recommendations for the protection of public exposure to RF electromagnetic energy established by government bodies and professional organizations, such as directives of the European Community, Directorate General V in matters of radio frequency electromagnetic energy.

## 3 Technical data

### 3.1 General specifications of terminal STEPP II

#### ❖ *Power supply:*

- Supply voltage from +10.8 V to +32.0 V (absolute maximum ratings) suitable for direct connection to an automotive +12V or +24V DC supply.

#### ❖ *Charging:*

- Supports externally connection to a Li-Ion battery (Note that the Li-Ion battery is not a part of terminal STEPP II).

#### ❖ *Temperature:*

- Normal operation (without connected battery): -40 °C to +85 °C (see chapter 3.1.2 for further details)

#### ❖ *Evaluation kit:*

- The STEPP II Eval-Board is designed to test, evaluate and make basis configuration to enable remote monitoring/configuration of the FALCOM STEPP II. It provides a sample configuration for application.

#### ❖ *Physical characteristics:*

- Size: 55.0 ± 0.15 mm x 80.0 ± 0.15 mm x 25.0 ± 0.15 mm
- Weight: ca. 80 g

#### ❖ *Audio:*

- 2 x Microphone, 2 x Speaker

#### ❖ *Firmware upgrade:*

- STEPP II firmware upgradeable over serial interface

#### ❖ *Serial Interface Setting:*

- Full duplex serial communication, CMOS level
- 2-wire (RxA and TxA) serial communication
- Baud rate: 9600 bps on the serial port
- 8 data bits, no parity, 1 stop bit, no hardware

#### ❖ *Casing:*

- Fully shield

**3.1.1 Power consumption**

Test conditions:

All measurements have been performed at  $T_{amb} = 25\text{ }^{\circ}\text{C}$ ,  $V_{IN+} = 12\text{ VDC}$  and 24 VDC. The heating/cooling system was not active.

<i>Average current at +12 V DC (without connected battery)</i>				
<b>GPS/GSM on</b> (Operating with firmware 1.6.2)	850/ 900	1800/ 1900	MHz	GSM band
	95	95	mA	in idle mode (base station sends at -85 dBm)
	170	140	mA	in transmit mode at power level 7/3
	205	160	mA	in transmit mode at power level 5/0 (maximum)
<b>GPS/GPRS on</b> (Operating with firmware 2.0RC1)	260		mA	in receive mode at maximum power level 5 (3 x downstream +2 x upstream using Coding Scheme 4 (CS-4))

**Table 2:** Power supply and current consumption at 12 V DC

<i>Average current at +24 V DC (without connected battery)</i>				
<b>GPS/GSM on</b> (Operating with firmware 1.6.2)	850/ 900	1800/ 1900	MHz	GSM band
	55	55	mA	in idle mode (base station sends at -85 dBm)
	102	85	mA	in transmit mode at power level 7/3
	120	95	mA	in transmit mode at power level 5/0 (maximum)
<b>GPS/GPRS on</b> (Operating with firmware 2.0RC1)	190		mA	in receive mode at maximum power level 5 (3 x downstream +2 x upstream using Coding Scheme 4 (CS-4))

**Table 3:** Power supply and current consumption at 24 V DC.

**3.1.2 Operating temperatures**

Parameter	Min	Typ	Max	Unit
Ambient temperature (according to GSM 11.10)	-40	25	85	$^{\circ}\text{C}$
Charging temperature (using an external battery)	0 $^{\circ}\text{C}$		+40	$^{\circ}\text{C}$

**Table 4:** Operating temperature

### 3.2 Technical specifications of GSM/GPRS engine\*

#### ❖ *Frequency bands:*

- Tri band: EGSM 900, GSM 1800, GSM 1900
- Tri band: EGSM 850, GSM 1800, GSM 1900
- Compliant to GSM Phase 2/2+

#### ❖ *GSM class:*

- Small MS

#### ❖ *Transmit power:*

- Class 4 (2 W) at EGSM900 and GSM850
- Class 1 (1 W) at GSM1800 and GSM 1900

#### ❖ *GPRS connectivity:*

- GPRS multi-slot class 10
- GPRS mobile station class B

#### ❖ *DATA:*

##### GPRS ⇒

- GPRS data downlink transfer: max. 85.6 kbps (see table 3).
- GPRS data uplink transfer: max. 42.8 kbps (see table 5).
- Coding scheme: CS-1, CS-2, CS-3 and CS-4. TCP/IP and PPP-stack.
- STEPP II supports two protocols PAP (Password Authentication Protocol) and CHAP (Challenge Handshake Authentication Protocol) commonly used for PPP connections.
- Supports of Packet Switched Broadcast Control Channel (PBCCH) allows you to benefit from enhanced GPRS performance when offered by the network operators.

##### CSD ⇒

- CSD transmission rates: 2.4, 4.8, 9.6, 14.4 kbps, non-transparent, V.110.
- Unstructured Supplementary Services Data (USSD) support.

##### WAP ⇒

- WAP compliant.

#### ❖ *SMS:*

- MT, MO, CB, Text and PDU mode
- SMS storage: SIM card plus 25 SMS locations in the mobile equipment
- Transmission of SMS alternatively over CSD or GPRS. Preferred mode can be user-defined.

❖ *SIM interface:*

- Support SIM card: 3 V

❖ *Temperature control and auto switch-off:*

- Constant temperature control prevents damage to module STEPP II when the specified temperature is exceeded. (see chapter 3.1.2 for further details)

❖ *External antenna:*

- Connected via 50 Ohm antenna connector.

❖ *Audio features:*

Speech codec modes:

- Half Rate (ETS 06.20)
- Full Rate (ETS 06.10)
- Enhanced Full Rate (ETS 06.50/06.60/06.80)
- Adaptive Multi Rate (AMR)

Handsfree operation

- Echo cancellation
- Noise reduction

❖ *Phonebook management:*

- Supported phonebook types: SM, FD, LD, MC, RC, ON, ME

❖ *Ringling tones:*

- Offers a choice of 7 different ringing tones/melodies, easily selectable with AT command

❖ *Real time clock:*

- Implemented

❖ *Timer function:*

- Programmable via SMS or \$PSRF commands

<b>Coding scheme</b>	<b>1 Timeslot</b>	<b>2 Timeslots</b>	<b>4 Timeslots</b>
CS-1:	9.05 kbps	18.1 kbps	36.2 kbps
CS-2:	13.4 kbps	26.8 kbps	53.6 kbps
CS-3:	15.6 kbps	31.2 kbps	62.4 kbps
CS-4:	21.4 kbps	42.8 kbps	85.6 kbps

**Table 5:** Coding schemes and maximum net data rates over air interface

Please note that the values listed above are the maximum ratings which, in practice, are influenced by a great variety of factors, primarily, for example, traffic variations and network coverage.

**\* Please note that not all features given above (in this chapter) are utilized in our firmware. Please, refer to the separated manual of the used firmware which is included on the delivered CD.**



**3.2.1 Air interface of the STEPP II GSM/GPRS part**

Test conditions:

All measurements have been performed at  $T_{amb} = 25\text{ }^{\circ}\text{C}$ ,  $V_{IN+ nom} = 12\text{ V}$ .

Parameter		Min	Typ	Max	Unit	
Frequency range Uplink (MS → BTS)	E-GSM 900	880		915	MHz	
	GSM 850	824		849	MHz	
	GSM 1800	1710		1785	MHz	
Frequency range Downlink (BTS → MS)	GSM 1900	1850		1910	MHz	
	E-GSM 900	925		960	MHz	
	GSM 850	869		894	MHz	
	GSM 1800	1805		1880	MHz	
	GSM 1900	1930		1990	MHz	
	RF power @ ARP with 50 Ω load	E-GSM 900	31	33	35	dBm
		GSM 850	31	33	35	dBm
		GSM 1800	28	30	32	dBm
GSM 1900		28	30	32	dBm	
E-GSM 900			174			
GSM 850			124			
GSM 1800			374			
GSM 1900			299		dBm	
Duplex spacing	E-GSM 900		45		MHz	
	GSM 850		45		MHz	
	GSM 1800		95		MHz	
	GSM 1900		80		MHz	
Carrier spacing			200		kHz	
Multiplex, Duplex	TDMA/FTDMA, FDD					
Time slots per TDMA frame			8			
Frame duration			4.615		ms	
Time slot duration			577		μs	
Modulation	GMSK					
Receiver input sensitivity @ ARP BER Class II < 2.4 %	E-GSM 900	-102	-107		dBm	
	GSM 850	-102	-107		dBm	
	GSM 1800	-102	-106		dBm	
	GSM 1900	-102	-105.5		dBm	

Table 6: Air Interface

**3.3 Technical specifications of GPS receiver**

❖ *GPS features:*

- OEM single board 12 channel GPS receiver, L1 1575.42 MHz, C/A code 1,023 MHz chip rate.
- GPS receiver with SiRFstarIIe/LP chip set
- Processor type ARM7/TDMI
- SiRF GSW2, version 2.20 (adapted for tracking solutions).

❖ *Accuracy:*

- Position 10 meters CEP without SA.

- Velocity 0.1 meters/second, without SA
- Time 1 microsecond synchronized to GPS time
- ❖ **DGPS Accuracy:**
  - Position 1 to 5 meters, typical
  - Velocity 0.05 meters/second, typical
- ❖ **Datum:**
  - WGS-84.
- ❖ **Acquisition Rate:**
  - Hot start <8 sec, average
  - Warm start <38 sec, average
  - Cold start <45 sec, average
- ❖ **Dynamic Conditions:**
  - Altitude 18,000 meters (60,000 feet) max.
  - Velocity <515 meters/second (1000 knots) max.
  - Acceleration 4 g, max.
  - Jerk 20 meters/second<sup>3</sup>, max.
- ❖ **Casing:**
  - Fully shield
- ❖ **Time – 1 PPS Pulse:**
  - Level CMOS.
  - Pulse duration 100 ms
  - Time reference At the pulse positive edge
  - Measurements Aligned to GPS second, ± μs
- ❖ **Supported protocols:**
  - NMEA Msg.: GLL, GGA, RMC, VTG, GSV, GSA
- ❖ **External antenna:**
  - Separate GPS antenna connector. See figure 37 for details
- ❖ **Memory:**
  - Combo-Memory (2 MB Flash–512 KB SRAM)

### 3.4 NMEA data message

The STEPP II device delivers data in the NMEA-0183 format. Table 7 lists each of the NMEA output messages supported by the STEPP II evaluation receiver and a brief description. For further description about NMEA see [Related documents](#)[4].

Option	Description
GGA	Time, position and fix type data.
GLL	Latitude, longitude, UTC time of position fix and status.

GSA	GPS receiver operating mode, satellites used in the position solution and DOP values.
VTG	The number of GPS satellites in view satellite ID numbers, elevation, azimuth and SNR values.
GSV	The number of GPS satellites in view satellite ID numbers, elevation, azimuth and SNR values.
RMC	Time, date, position, course and speed data.

**Table 7:** NMEA Output Messages

## 4 Functional description

### 4.1 How does it works

It can be powered from +10.8 to +32.0 VDC. It integrates a charging management which allows attachment to a Li-Ion backup battery. If the battery voltage is going low, to charge it just supply the terminal (via VC+ and GND pins) with aforementioned power source (e.g. car battery). The user external connected battery is internally monitored. A circuit example is shown in the chapter 6.1.2.4. Attached battery allows operation of terminal for some hours (it depends on the capacity of user chosen battery pack) in case of operating voltage (i.e. car battery) failure.

A general purpose terminal providing multiple digital/analogue inputs and outputs for a different variety of uses.

The STEPP II provides 2 analogue inputs, that are very convenient to monitor a tachometer generator, a temperature sensor as well fuel level and etc. Circuit examples for digital inputs are attached on the chapter 6.1.2.1. It also provides 4 digital inputs that can be used to trigger alarm SMS (i.e. they can be connected to the car alarm, to a door switch or customer specific requirements (e.g.: Panic button)). Circuit examples for digital inputs are attached in chapter 6.1.2.2. 4 digital outputs are provided to switch on/off external devices. Circuit examples for digital outputs are attached in chapter 6.1.2.3.

Three other inputs are pre-defined by the manufacturer:

- 1 x Power Supply line → which has to be connected to the vehicle battery (clamp 30) or another power source.
- 2 x Ignition lines → which can be connected to the vehicle starter lock (clamp 15).

To use the STEPP II you need to insert a SIM card (available for SMS, data and voice calls. The different services, i.e. Voice, Data and SMS depend on your application) and to install the terminal indoor at the supposed location (e.g. vehicle, boat etc.). STEPP II comes with a combined GSM/GPS antenna. To achieve an accurate geographical location of STEPP II, it is important to place the GPS antenna so that it has a clear view to the sky (no obstacle). The STEPP II terminal is not water resistant, please, give careful consideration to the installation location of terminal. The configuration of the terminal can be done by using a serial interface connection (locally) or over GSM network (remotely) using SMS commands. *Note that*, in order to configure the STEPP II remotely the basis configuration has to be locally executed. Once the basis configuration of the STEPP II terminal is locally set and stored (using STEPP II Eval-Board und Configuration software) then by means of provided SMS and PSRF commands it can be remotely configured or present configuration can be changed. You can then control it from a remote mobile phone via SMS. The GPS position or current configuration can be received by means of any GSM phone or PC connected to a GSM modem (able to send/receive SMS, data and voice calls). Thus, you will be able remotely to monitor the position of trucks, cars and boats (with a GSM/GPRS coverage) and to receive an alarm if the device has moved from a marked position (e.g. if your truck, car or boat has been stolen), deviates off a route or to detect if a car leaves a country.

The FALCOM STEPP II comprises also two audio interfaces available on the provided connectors:

- ❖ Two analog audio interfaces, each with a balanced analog microphone input and a balanced analog earpiece output. Both analog interfaces provide supply circuits to feed active microphones.

This means you can connect up to two audio devices in any combination. An audio interface allows the direct connection of a headset. An example of a possible installation is shown in the Appendix of this manual. The voice channel of STEPP II allows you to conduct a normal telephone conversation. For this, STEPP II operates in free-speech mode. Requirements are to connect a loud speaker (pins 13 and 15) and a free-speech microphone (pins 14 and 16) on the 16-pin connector interface of the STEPP II.

After that the terminal is connected to the aforementioned power supply, its actual status is displayed by three LED's on the front side of terminal. The red LED indicator will flash during the internal initialization of STEPP II terminal. If ambient temperature and the voltage of external connected battery are correct the red LED indicator will switch off.

STEPP II provided LED's		
Name	LED mode	Function
BAT (Red LED*)	OFF	Terminal is off or turned on and ambient temperature is OK.
	100 ms On/30 ms Off/ 100 ms On/1 s Off	Ambient temperature is higher than ca. 40 °C. The charging/discharging process is turned off.
	100 ms On/1 s Off	Ambient temperature is lower than ca. 0 °C. The charging/discharging process is turned off.
	100 ms On/3 s Off	The voltage of external connected battery is lower than ca. 3.5 V.
GSM (Green LED)	Off	Terminal is off or run in SLEEP mode
	600 ms On/600 ms Off	No SIM card inserted or no PIN entered, or network search in progress, or ongoing user authentication, or network login in progress.
	75 ms On/3 s Off	Logged to network (monitoring control channels and user interactions). No call in progress.
	75 ms On/75 ms Off/ 75 ms On/3 ms Off	One or more GPRS contexts activated.
	Flashing	Flashing Indicates GPRS data transfer: When a GPRS transfer is in progress, the LED goes on within 1 second after data packets were exchanged. Flash duration is approximately 0.5 s.
	On	On Depending on type of call: <i>Voice call:</i> Connected to remote party. <i>Data call:</i> Connected to remote party or exchange of parameters while setting up or disconnecting a call.

GPS (Yellow LED)	ON	Terminal is searching for satellites. Terminal receives invalid GPS position, no GPS fix obtained.
	Flashing (4 sec. interval)	Start-up GSM error (i.e. no SIM card inserted or incorrect PIN configuration or is not ready for operation)
	Continually flashing	Valid GPS data are being received, terminal has obtained a GPS fix and ready for use.

**Table 8:** Modes of the LED's and associated functions

\* Please note that, this LED also works even if no external battery is connected to the STEPP II, but in this case its functionality is invalid.

## 4.2 FALCOM STEPP II typical applications

The STEPP II is a plug and play device that can be used as mobile client in different variety of system solutions:

- ❖ **Tracking**  
*The vehicle to be tracked is fitted with a STEPP II and an antenna. GPS satellites are continuously transmitting information, including when the data being sent, which satellite sent it and the current reliability of the system. The STEPP II fitted in the vehicle, receives this information from at least 4 satellites and carries out the necessary calculations to determine its current position.*
- ❖ **AVL**  
*The embedded GPS receiver into the STEPP II determines its current location, speed and heading. This data can be stored or can be directly transmitted to a control centre. The terminal reports its position to the base station over GSM or GPRS (Internet) communications network. Current position can also be displayed on a digital maps installed on PC/PDA.*
- ❖ **Security**  
*Such as Telephone, Position, Speed/Course, Temperature, Remote reading, Alarm, Movement, Fire, Gas, Water level and many others.*
- ❖ **Setting alarm inputs**  
*For each input several telephone numbers (destination numbers) can be configured. Beside the destination number, alarm text as SMS with the desired GPS protocol (max. 2 protocols) can be configured. The alarm type could also be voice, and data connection.*
- ❖ **Remote Monitoring**
- ❖ .....

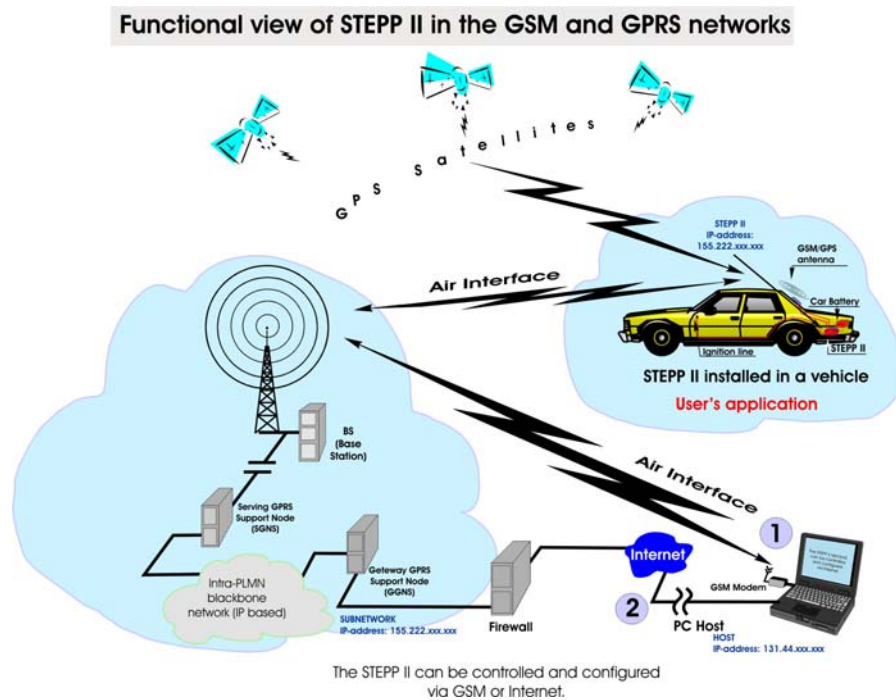

Normally the GPS antenna must be placed in a position where it can see the sky. To get a valid position, the STEPP II should get information from at least 3 satellites.

The STEPP II supports two software (known as “firmware”).

- ❖ Depending on the configuration, the device exchanges data with a server application (e.g. Mapping-Software, etc.). The STEPP II can be configured by the user via local RS232-interface or remotely over the GSM (air link see diagram marked ❶). This configuration is based on the STEPP II operating with firmware version 1.6.2. Please, refer to the issued manual “[stepp\\_II\\_software\\_1.6.2\\_manual.pdf](#)”.
- ❖ The STEPP II terminal supports a firmware, using TCP/IP stack and PPP protocol, according to the user configuration, terminal is able to establish a GPRS data connection. Via GPRS (see diagram marked ❷) it is possible that the vehicle's current location can be polled and displayed or the vehicle can be tracked "live" second by second on a mapping software. This configuration is based on the STEPP II operating with firmware version 2.0RC1. The firmware version 2.0RC1 is under development, however, for the end-user FALCOM releases the first version. This firmware version provides limited TCP commands (so far limited configuration, a full configuration is in preparation). Please, refer to the issued manual “[stepp\\_II\\_software\\_2.0RC1\\_manual.pdf](#)”.

## 5 STEPP II application interface

### 5.1 Power supply

The power supply for the STEPP II terminal has to be a single voltage source of  $V_{VC+} = +10.8 \text{ V} \dots +32.0 \text{ VDC}$ . It must be able to provide sufficient current in a transmit GSM burst which typically rises to 1.6 A.

The operating voltage ( $V_{VC+}$  and GND) is protected from reverse pole connection.

All the key functions for supplying power to the device are handled by an ASIC power supply. The ASIC provides the following features:

- ❖ Stabilizes the supply voltages for the GSM base band using low drop linear voltage regulators.
- ❖ Controls the module power up and power down procedures.
- ❖ A watchdog logic implemented in the base band processor periodically sends signals to the ASIC, allowing it to maintain the supply voltage for all digital components of STEPP II GSM/GPRS core. Whenever the watchdog pulses fail to arrive constantly, the terminal is turned off.
- ❖ Provides power to the SIM interface, digital outputs, handsfree set as well as heating/cooling system.

Keep in mind that, operating voltage ( $V_{VC+}$ ) has to be permanently applied to the terminal, because of several STEPP II components such as digital outputs, handsfree-set as well heating/cooling system do not operate only from the external battery. These components are operational as long as the main power ( $V_{VC+}$ ) is applied to the STEPP II terminal.

#### 5.1.1 Power up/down scenarios

In general, be sure not to turn on the STEPP II terminal module while it is out of the operating range of voltage and temperature stated in [Table 11](#) and [Table 4](#). The STEPP II terminal would immediately switch off after having started and detected these inappropriate conditions.

#### 5.1.2 Power supply pins (14, 15 and 16) on the 16-pin connector

One  $VC+$  pin of the 16-pin connector is dedicated to connect the supply voltage, 3 GND pins are recommended for grounding.

The  $VBAT+$  and GND pin serve for charging/discharging an external Li-Ion battery.

Signal name	I/O	Parameter	Description
$VC+$	I	+10.8 V...+32.0 VDC, $I_{typ} \leq 1.6$ during transmit burst. The minimum operating voltage must not fall below +10.0 VDC, not even in case of voltage drop.	Positive operating voltage.
GND	-	0 V	Ground
$VBAT+$	I/O	Charging/discharging an external Li-Ion battery under these conditions:	A Li-Ion battery can be connected to this line. Do not connect



		450 mA max at +4.2 VDC	this line to any external device (except recommended batteries), power supply or grounds.
--	--	------------------------	---

### 5.1.3 Automatic shutdown

Automatic shutdown takes effect if:

- ❖ the STEPP II board is exceeding the critical limits of over or under temperature.
- ❖ the battery is exceeding the critical limits of over or under temperature.
- ❖ under voltage is detected.

The automatic shutdown procedure is equivalent to the power-down initiated, i.e. STEPP II logs off from the network and the software enters a secure state avoiding loss of data.

#### 5.1.3.1 *Over voltage shutdown*

For over voltage conditions, no software controlled shutdown is implemented. If the supply voltage exceeds the maximum value specified in [Table 12](#), loss of data and even unrecoverable hardware damage can occur.

## 5.2 Automatic GPRS Multislot Class change

Temperature control is also effective for operation in GPRS Multislot class 10. If the board temperature exceeds the specified limit (*see 3.1.2 for temperature limits known as restricted operation*) while data are transmitted over GPRS, the module automatically reverts from GPRS Multislot class 10 (3 RX x 2 TX) to class 8 (4 RX x 1 TX). This reduces the power consumption and, consequently, causes the temperature of board to decrease. Once the temperature drops to a value of 5 degrees below the limit of restricted operation, STEPP II returns to the higher Multislot class 10. If the temperature stays at the critical level or even continues to rise, STEPP II will not switch back to the higher class. After a transition from Multislot class 10 to Multislot class 8 a possible switchback to Multislot class 10 is blocked for one minute. Please, note that there is no one single cause of switching over to a lower GPRS Multislot class. Rather it is the result of an interaction of several factors, such as the board temperature that depends largely on the ambient temperature, the operating mode and the transmit power. Furthermore, take into account that there is a delay until the network proceeds to a lower or, accordingly, higher Multislot class. The delay time is network dependent. In extreme cases, if it takes too much time for the network and the temperature cannot drop due to this delay, the terminal may even switch off.

## 5.3 Determining the External Equipment Type

Before you connect the serial port pins on the aforementioned terminals (DCE units) to external equipment, you need to determine if the external hardware serial ports are configured as DTE or DCE.

The FALCOM STEPP II is designed for use as a DCE. Based on the aforementioned conventions for DCE-DTE connections it communicates with the customer application (DTE) using the following signals:

STEPP II terminal (DCE)	to	Application (DTE)
RxA	←-----	TXD
TxA	-----▶	RXD

**Table 9:** The signalling definitions between DTE and DCE.

## 6 Hardware Interfaces

This chapter describes the hardware interfaces:

- pinout on the 16-pin (Molex) connector
- pinout on the 15-pin (AMP) connector
- RF interfaces
- SIM interface
- LED's indicator

Interface specifications	
Interface A	16-pin Molex 43045-1609
Interface B	SIM card reader for small SIM cards (3V)
Interface C	GPS RF Connector 50 $\Omega$ Fakra/Radiall (SMB-Male)
Interface D	GSM RF Connector 50 $\Omega$ Fakra/Radiall (SMB-Male)
Interface E	15-pin AMP 5-558556-1
Interface F	Optical GSM/GPS LED's

Table 10: Interface specifications

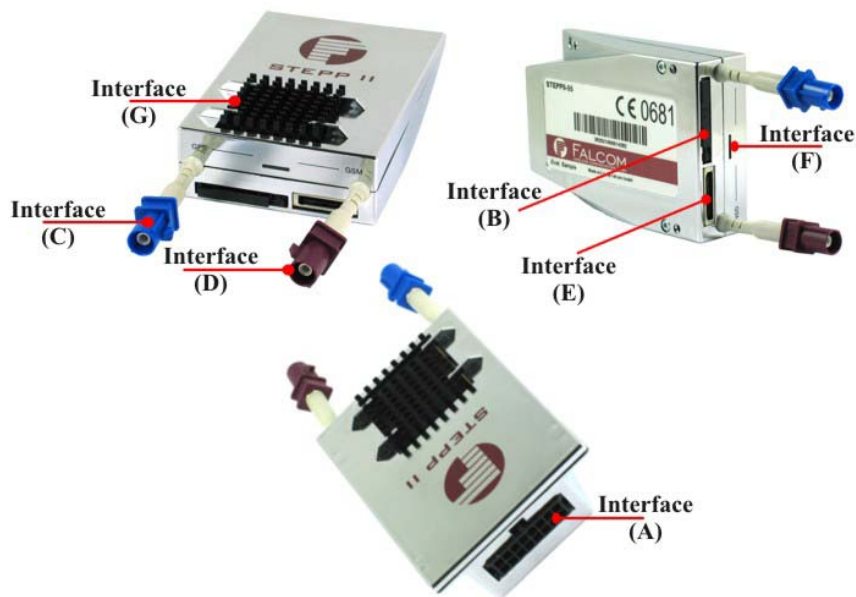

Figure 3: Interface specifications

### 6.1 Interface A (16-pin Molex 43045-1609)



Figure 4: View of the 16-pin Molex 43045-1609 connector pin assignments

#### 6.1.1 Description of the 16-pin connector

PIN	NAME	I/O	DISCRIPTION	LEVEL
1	MIC N1	I(-)	Balanced microphone input. Can be used to directly feed an active microphone. If not used leave it open.	$R_I \approx 50 \text{ k}\Omega$ differential $V_{I\text{max}} = 20 \text{ mVpp}$
3	MIC P1	I(+)		
2	Analog Input 2	I	General propose analog inputs	up to 32 V DC/8 bit resolution
4	Analog Input 1	I		
5	Out 2	O	Open collector outputs.	300 mA max. at +10.8 .. +32V DC
7	Out 1	O		
9	Out 3	O		
11	Out 4	O		
6	Inp 4	I	General propose inputs	<b>HIGH</b> $\geq +10.8 \dots +32 \text{ V DC}$ <b>LOW</b> = 0V
8	Inp 3	I		
10	Inp 2	I		
12	Inp 1	I		
13	IGN	I		10.8 .. 32 V DC
14	VBAT+	I/O	This line is a current source for an external battery. Supplies the terminal with power if no external power supply to the terminal is applied (e.g.: Vehicle battery). If not used leave it open. <b>Do not connect this pin to the VC+ line or GND.</b>	max. 450 mA at 4.2 VDC
15	VC+	I	Power supply input (Input 7). The power supply must be able to meet the requirements of current consumption in a Tx burst	$V_I = +10.8 \dots +32.0 \text{ V} \pm 5 \%$ $I_{\text{max}} \leq 2 \text{ A}$ (during Tx burst) 1 x Tx, peak current

			(up to 2 A). Sending with two timeslots doubles the duration of current pulses to 1154 $\mu$ s (every 4.616 ms)!	577 $\mu$ s every 4.616 ms 2 x Tx, peak current 1154 $\mu$ s every 4.616 ms
16	GND	-	Negative operating voltage (ground).	0 V

Table 11: Pin description of 16pin Molex connector

### 6.1.2 Special pin description

#### 6.1.2.1 *Analog inputs (pin 2, 4)*

Analog voltages up to 32 V with 8 bit resolution can be processed and remotely evaluated by a server application. Pull-up resistor to a constant input voltage allows for resistive transducers to ground, e.g. fuel sensor or thermistors.

↓ **Connection example for analog input 2:**

Thus, pin 2 (analog input 2) can be connected to a temperature sensor (a NTC resistor for instance). It is possible to set a low temperature alarm and a high temperature alarm (upper and lower values), passed to required temperature. Passage through these thresholds will trigger an alarm. We recommend to use SMS as alarm type with the protocol GPIOP (SMS including voltage values and text. It depends on the user configuration). The SMS can be received on a mobile phone, modem or any GSM device, see illustrated example in figure below:

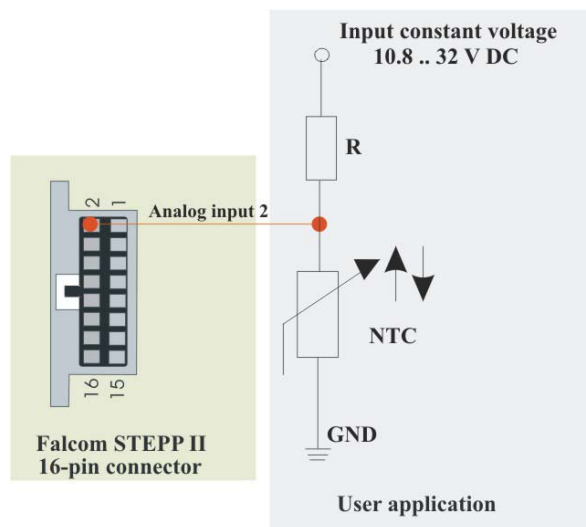
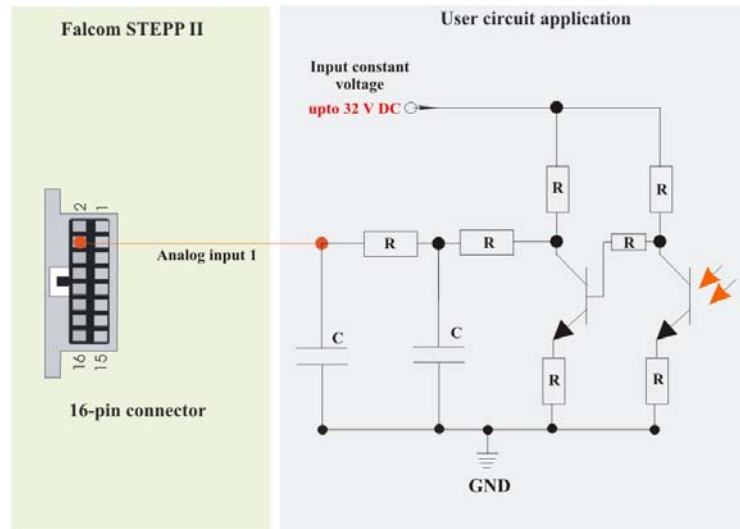

Figure 5: Connection example for analog input 2

↓ **Connection example for analog input 1:**

Likewise, on pin 4 (analog input 1) you can install a tachometer generator. Its functionality is just like pin 2 (analog input 2). The maximum output voltage of the tachometer is +32 V (see illustrated example in figure below).

**NOTE: Both circuit examples (the NTC (above) and the Tachometer) are only illustration to show the aim of the analog inputs.**



**Figure 6:** Connection example for analog input 1

**6.1.2.2 Inputs (pin 6, 8, 10, 12)**

The inputs (pin 6, 8, 10, 12) on the 16-pin connector are high active so they can be connected to +10.8 ... 32 V DC. The figure below illustrates how to connect these inputs. If one of connected pins (inputs) is activated (for at least 1 sec), STEPP II will release an alarm (SMS, Voice or data connection). The alarm type and the alarm text (alarm type SMS) depend on the configuration done by the user. The inputs can be configured by using the configuration software (Configurator\_2.2). All inputs reserved for customer specific applications can be connected as shown below:

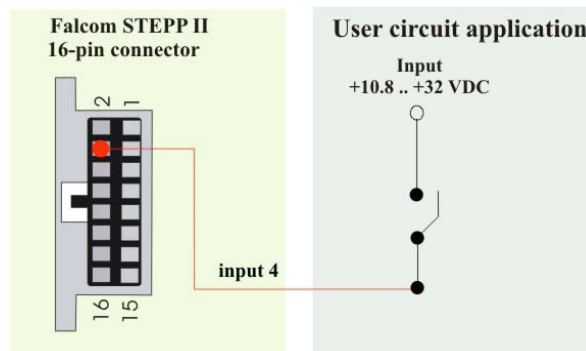
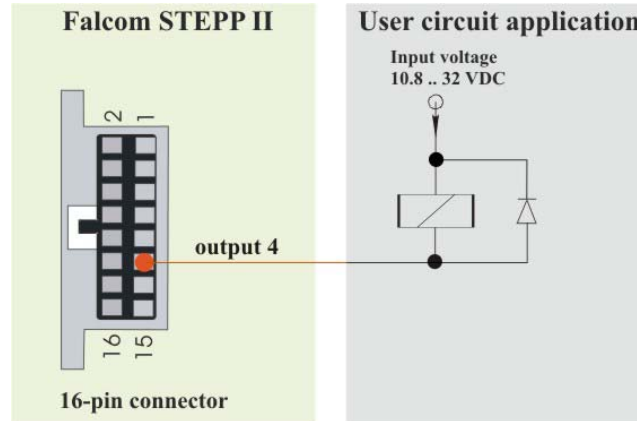

**Figure 7:** Connection example for input 4

A completed circuit example for all inputs is attached in section [10.1.1](#).

**6.1.2.3 Outputs (pin 5, 7, 9, 11)**

The STEPP II supports four outputs. These can be set remotely by the server application. The figures below show the schematic of possible output connections.



**Figure 8:** Connection example 1 for output 4 (Relay)

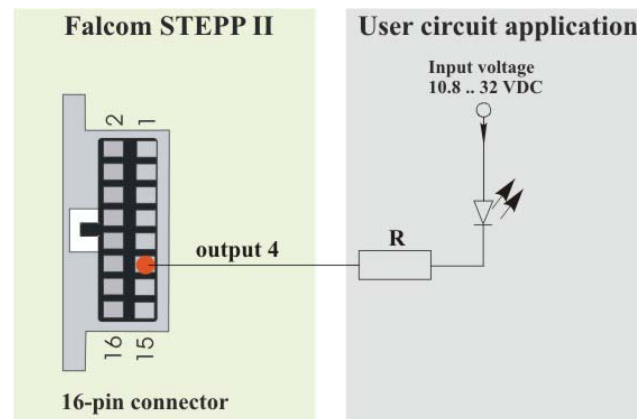

**Figure 9:** Connection example 2 for output 4 (LED)

A completed circuit example for all outputs is attached in section [10.1.1](#).

**6.1.2.4 VBAT (pin 14)**

The charging algorithm has been optimized for a Li-Ion battery pack. It is recommended that the battery pack you want to integrate into your STEPP II application is compliant with these specifications.

- ❖ Li-Ion battery pack specified for a maximum charging voltage of 4.2 V and a capacity of 700 mAh. Battery packs with a capacity down to 600 mAh or more than 800 mAh are allowed, too. Higher capacity of integrated battery pack offers better functionality of the STEPP II terminal.
- ❖ The charging current is limited of 450 mA.
- ❖ On-board battery circuit with current limiter charging of 450 mA that charges lead battery constantly.
- ❖ Ensure that the pack incorporates a protection circuit capable of detecting over voltage (protection against overcharging), under voltage (protection against deep discharging) and over current.

- ❖ The internal resistance of the battery and the protection should be as low as possible. It is recommended not to exceed 150 mΩ, even in extreme conditions at low temperature. The battery cell must be insensitive to rupture, fire and gassing under extreme conditions of temperature and charging (voltage, current).
- ❖ The contacts of battery pack must be protected from short circuits. For example, use rubber-band or cable isolation on the contacted parts to prevent short circuits.
- ❖ The battery pack must be approved to satisfy the requirements of CE conformity.

The circuit diagram below shows how to connect a Li-Ion battery to the STEPP II terminal. The charging/discharging process is implemented internally. The charging process take place only if the operating voltage is applied. If the STEPP II is not in use for a long time (e.g. warehouse) this pin (VBAT+) can be left open (remove the battery).

**Warning !** *The battery circuit is not protected from reverse pole connection. To prevent the mounting of battery in reverse polarity, mount it before the power supply is applied to the terminal. Then check again the connected wires from STEPP II to external user battery pack. If they are properly connected, supply the terminal with external power (i.e. car battery). Otherwise, if battery will be mounted with reverse pole while the operating voltage ( $V_{VC+}$ ) is applied to the terminal, some on-board electronic components of terminal can be damaged.*

!!! Take care not to connect the battery with the wrong polarity.

**Caution:** 1) *Please, keep in mind that the pin (VBAT+) has in no case to be connected neither to the operating voltage ( $V_{VC+}$ ) pin nor to the GND pin.*

2) *Charging process can only be accomplished in a temperature range from 0 °C to +40 °C, typically 15 to 25 °C.*

*The extreme temperatures have an unfavourable influence on the rechargeable batteries. The capacity and life cycle of the batteries are reduced if they are kept at cold or warm places, e.g. in a closed car at summer or winter conditions. Try always to keep the connected battery (STEPP II) at normal temperatures between 15 °C and 25 °C.*

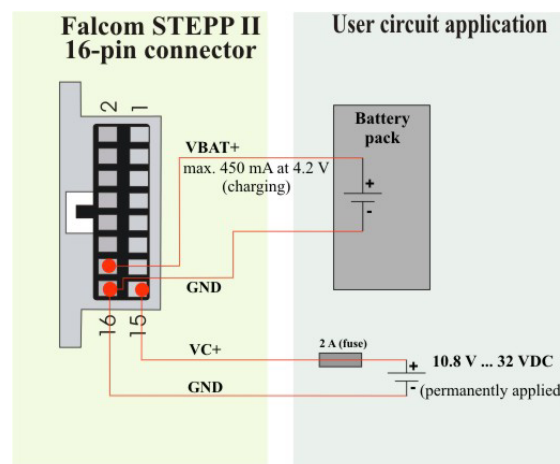

**Figure 10:** VBAT+ connection example



6.1.2.4.1 Why is required to connect a backup battery

The Li-Ion batteries (e.g. 1100 mA/h) provide sufficient current from which the STEPP II can also continue to operate (except digital outputs, handsfree set as well heating/cooling system which do not operate only from the external battery) in case of operating voltage failures. So, in this way it enables the STEPP II terminal sending/receiving SMS, establishing a data or voice call or establishing a GPRS connection.

6.1.2.5 Ignition (pin 13)

STEPP II provides two Ignition pins (pin 13) on the Molex and AMP connectors. Their functionality is the same. The vehicle ignition line (starter lock clamp 15) can be connected to one of the IGN pins of terminals (Pin 13). Thus, it is possible to send an alarm SMS (by starting the car engine), prerequisite, the input IGN of the STEPP II should be configured for this purpose. Both pins 13 on the Molex connector and AMP connector are internally connected with each other, so they can be alternatively used. For more information see the corresponding figure in chapter 10.1.1. Note that the STEPP II's IGN pins are not assumed to switch on the STEPP II terminal, they are only inputs pin which can be used for specific customer requirements.

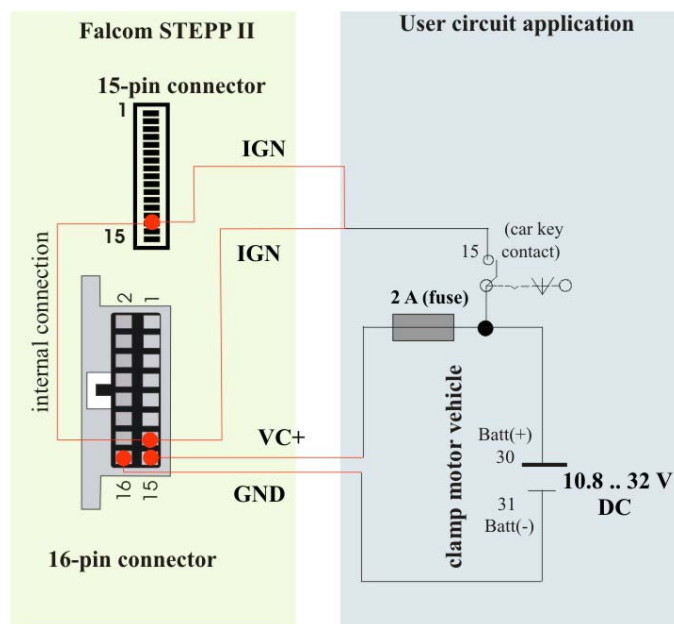

Figure 11: Ignition connection example

## 6.2 Interface B (SIM card interface Molex-91228-0002)

The figure below shows the SIM card reader interface of the STEPP II.



**Figure 12:** View of the SIM card interface

The SIM interface controls a internal small 3 V SIM card. This interface is fully compliant with GSM 11.11 recommendations concerning SIM functions.

**Note:** The SIM should not be removed, while the module is powered on. The SIM must only be removed when the STEPP II is shut down. To remove the SIM card press the Eject button (see figure 12) then pull out the SIM card holder.

**Note:** The unit is not designed for use of single 5 V SIM cards. These cards will generate an error which cannot be distinguished from a faulty SIM card.

### 6.3 Interfaces C and D

The STEPP II is fitted with two male SMB FAKRA connectors that accept a wide variety of GSM/GPS antenna styles. One of them (right) (see figure below), is provided for GSM RF connection. The GSM RF connector has an impedance of 50  $\Omega$ . A GSM antenna can be directly connected to this connector.

The other left-one is provided for GPS RF connection. The GPS RF connector (see figure below) has an impedance of 50  $\Omega$ . Active antennas have an integrated low-noise amplifier. They can be directly connected to this connector. The integrated low-noise amplifier of the antenna is internally supplied with the specified voltage.

FALCOM GmbH provides a combined GSM/GPS antenna, especially, for the STEPP devices, the GSM antenna operates on four frequencies: GSM 850/900 MHz and DCS 1800/1900 MHz. The GPS antenna operates on 1575.42 MHz frequency. This antenna is suitable for mounting, covertly if required, in various locations.

The order name of combined GSM/GPS antenna is: **FAL-ANT-5**

**Hint:** In order to operate properly the GPS part, it is recommended the GPS active antenna should not exceed 25 mA. The antenna voltage is supplied internally. The GPS antenna is protected from reverse pole connection.

The figure below shows the position of GSM/GPS connectors.



**Figure 13:** View of the GSM/GPS antenna cable.

Both GSM/GPS antenna cables with their FAKRA connectors are connected to STEPP II. Both GSM and GPS antenna cables have the same length.

### 6.4 Interface E (AMP 558556-1 Connector)

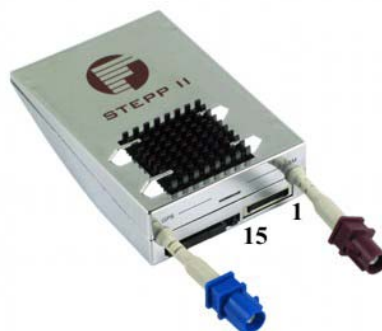

**Figure 14:** View of the 15-pin AMP5-558556-1 connector pin assignments

**CAUTION** - Insert the 15-pin AMP adapter kindly into the AMP slot of terminal. Forcing the adapter may damage the connector pins. If you feel any resistance while inserting the adapter into the AMP slot of terminal, remove it immediately and check for any damage of its connector or bend pins.

**6.4.1 The 15- pin connector description**

PIN	NAME	I/O	DISCRIPTION	LEVEL
1	GND	-	Negative operating voltage (grounds).	0 V
2	GND	-		0 V
3	SPK N1	O(-)	Analogue audio interface. Balanced audio output. Can be used to operate directly an earpiece. This audio interface is without amplifier. If not used leave it open.	$V_{Omax} = 1.3 V_{pp}$
4	SPK P1	O(+)		
5	VC 5	O	Power supply output. Can be used to supply external equipment which requires the same voltage level.	100 mA at 5 V $\pm 5\%$ VDC
6	VB		Battery controller	
7	MIC N2	I(-)	Balanced microphone input. Can be used to feed directly an active microphone. If not used leave it open.	$R_I \approx 50 \text{ k}\Omega$ $V_{Imax} = 20 \text{ mVpp}$
8	MIC P2	I(+)		
9	SPK N2 with amplifier	O	Analogue audio interface. Balanced audio output. Can be used to operate directly an earpiece. If not used leave it open.	8 $\Omega$ /1 W
10	SPK P2 with amplifier	O		
11	Boot select	I	STEPP II boots in debug mode if this pin is set to low. Connect it to GND in case of firmware update. For normal operation leave it open.	0 V (ground)
12	NC	-	Not connected	-
13	IGN2	I	Input 8	+10.8 ... +32 V
14	RxA RS232	O	Serial interface for direct connection to the host PC (configuration, evaluation, receiving history data and others) or to the STEPP II Eval-Board. If not used leave open.	V24, $\pm 12 \text{ V}$
15	TxA RS232	I		

Table 12: Pins description of 15-pin AMP connector

**6.4.2 Special pin description**

**6.4.2.1 VC 5**

This output can be used to power some external functions. VC 5 has to be used as a power supply for external user applications which require 100 mA

at  $5\text{ V} \pm 5\%$  VDC. This power supply is available when the terminal is switched on. To use this pin see chapter 10.1.2.

**6.4.2.2 Boot select**

To update a new STEPP II firmware, this pin should be linked to GND (ground). Leave it open for a normal STEPP II operation (tracking, call, etc.).

**6.4.2.3 Serial communication signals (RxA, TxA)**

The board supports a full duplex serial channel. The serial connection is at V24,  $\pm 12\text{ V}$  level. You do not need to use any level shifter. The signals on these pins are obtained to RS232 compatible signal levels. All supported variable baud rates can be controlled from any terminal software. You can directly communicate with a PC serial port. It is recommended to use the STEPP II Eval-Board in order to communicate with terminal.

RxA This is the main receiving channel and is used to receive software commands to the board from any terminal software (e.g. HyperTerminal) or from user written software.

TxA This is the main transmitting channel and is used to output navigation and measurement data to any terminal software (e.g. HyperTerminal) or user written software.

**6.4.2.4 Speaker outputs characteristics**

A speaker can be connected directly to the pin 9 and pin 10. The standard level is  $8\ \Omega/1\text{ Watt}$ .

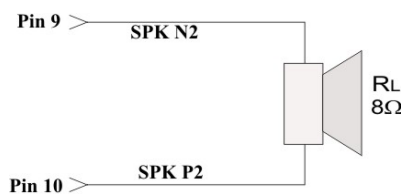

PIN	NAME	DESCRIPTION	LEVEL
9	SPK N2 with amplifier	Speaker 2 negative output	$8\ \Omega/1\text{ W}$
10	SPK P2 with amplifier	Speaker 2 positive output	$8\ \Omega/1\text{ W}$

**Table 13:** Description of recommended speaker characteristics.

**6.5 Interface F (LED's description)**

The actual state of the STEPP II is displayed by three LED's on the interface D of the terminal.

The following description shows the function of these LED's.

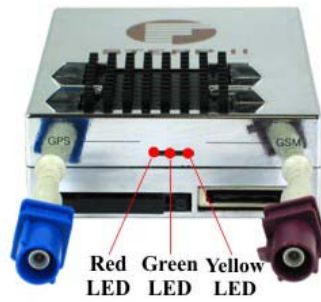

**Figure 15:** View of the GSM/GPS LED's

Three provided LED's show the actual state of the STEPP II terminal:

- Red (Battery): Battery status and ambient temperature (about its functionality see [Table 8](#)).
- Green (GSM): GSM network status (about its functionality see [Table 8](#)).
- Yellow (GPS): GPS status (about its functionality see [Table 8](#)).

### 6.5.1 Interface E (Mounting holes)

The STEPP II compact terminal provides 4 holes for attaching it to the suitable cradle. As a reference for mounting holes use figure 16 below in this section. The cradle is in the sales package.

In order to avoid any damage during mounting of the terminal, is required to use (choose if the screws are damaged) properly the screws delivered with STEPP II. Fasteners are 22 x 6 mm screws plus suitable washers, or customized screws.

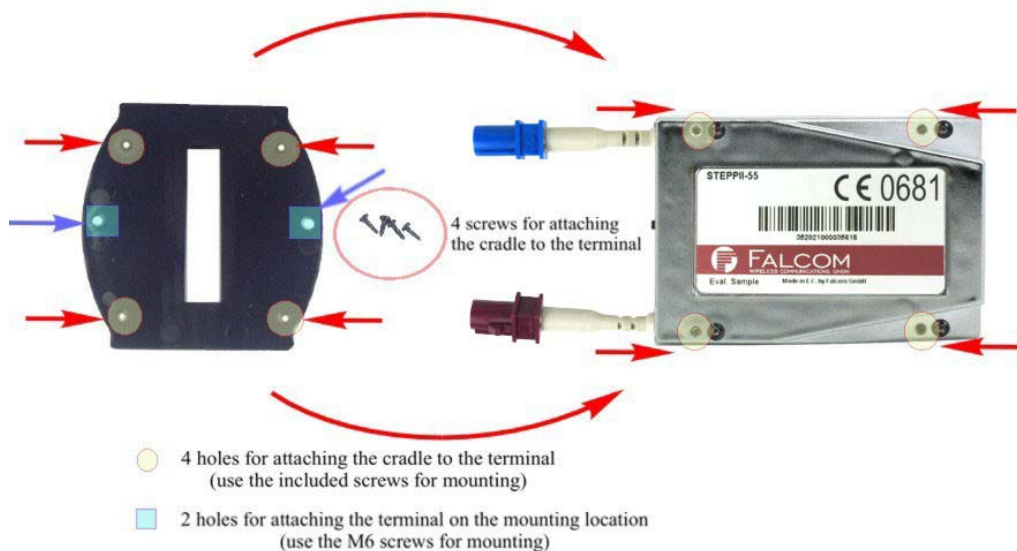

**Figure 16:** View of the mounting holes

### 6.5.1.1 Mounting the cradle to the terminal



**Figure 17:** Attached cradle to the terminal.

In order to avoid any damage during mounting, place the terminal (if needed) on the cradle and push it up/down till you see both terminal and cradle holes are facing each other. Screws must be inserted with the screw head on the bottom of cradle through to the provided holes on the bottom of the STEPP II. Use a suitable screwdriver to perform the rotation. Screw up kindly the appropriate screws. To avoid short circuits ensure that the customized screws (screws with different length) do not come into contact with the STEPP II PCB since there are a number of test points. Make sure that the STEPP II does not move up and down inside the cradle.

After you have secured up the cradle to the terminal, choose the mounting location (see next section). The terminal can be mounted in different locations on a wall or vehicle, metal or non-metal sheets. Its depends on the user's application. As a reference for mounting holes use figure 16 (blue colour).

### 6.5.1.2 Placing the terminal

**Caution:** In order to comply with RF exposure requirements, install the terminal so that a minimum distance of 20 cm can be maintained between the antenna and persons. If you use an external antenna, install the antenna so that a minimum distance of 20 cm can be maintained between the antenna and persons, with antenna gain not exceeding 3 dBi.

Place mounted terminal in a proper location:

1. The mounting location must be chosen far enough from electronic devices so that no interference takes place. Please, contact your vehicle supplier for more information.
2. Make sure the screws are suitable for mounting plate.
3. Drill appropriate screws (M6) the two indentations on the cradle.
4. Secure the cradle and terminal are firmly fixed on the selected mounting place.

**Note:** All radio transmitting devices send signals which may cause interference in different electronic devices (PC, television or electronic devices etc). To avoid interference, place the terminal far enough from other electronic devices.

## 7 Housing

The housing material: Galvano-ABS, gloss-chromium-plated.

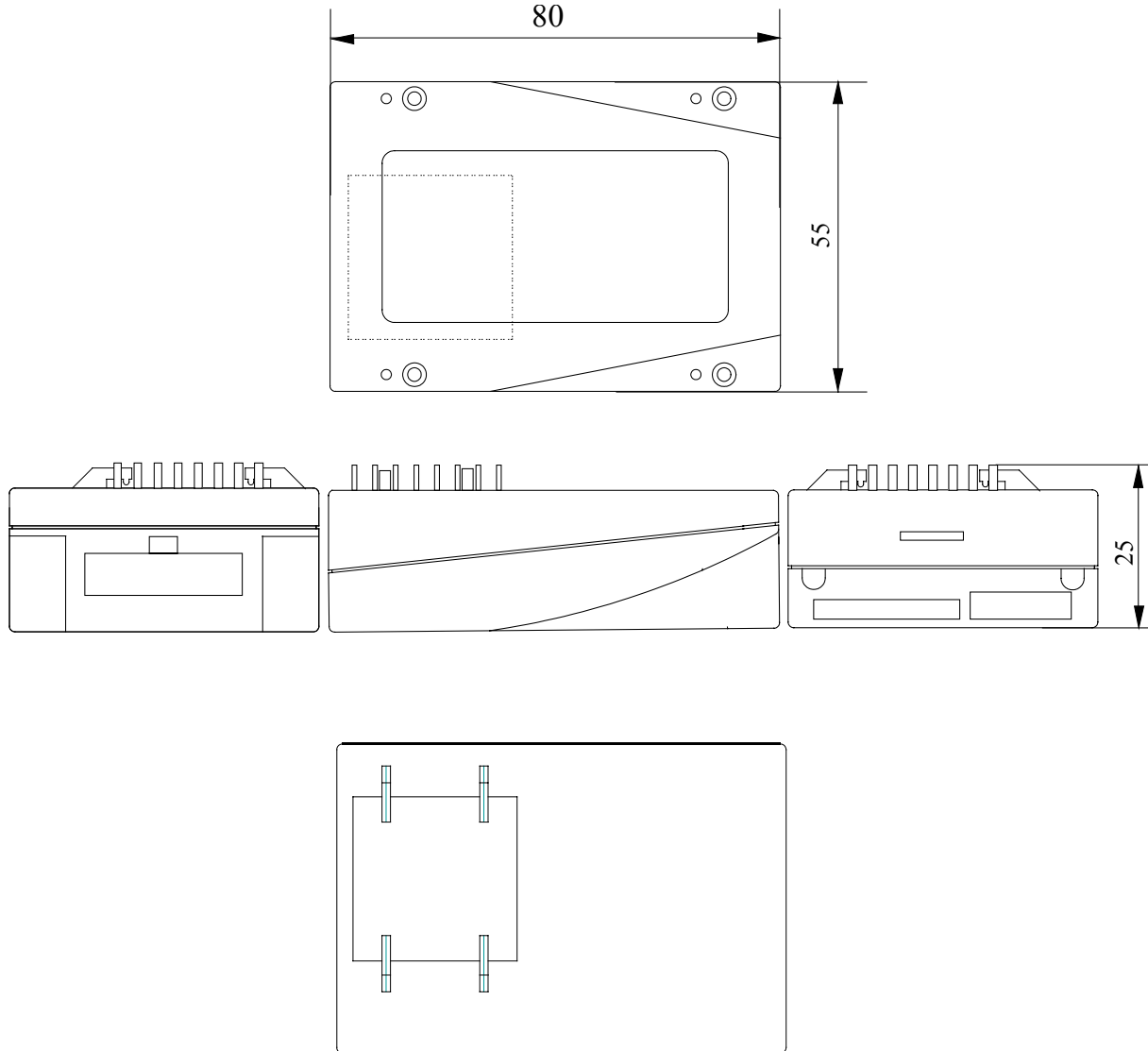

**Figure 18:** Housing of the STEPP II.



## 8 STEPP II-Mounting cradle

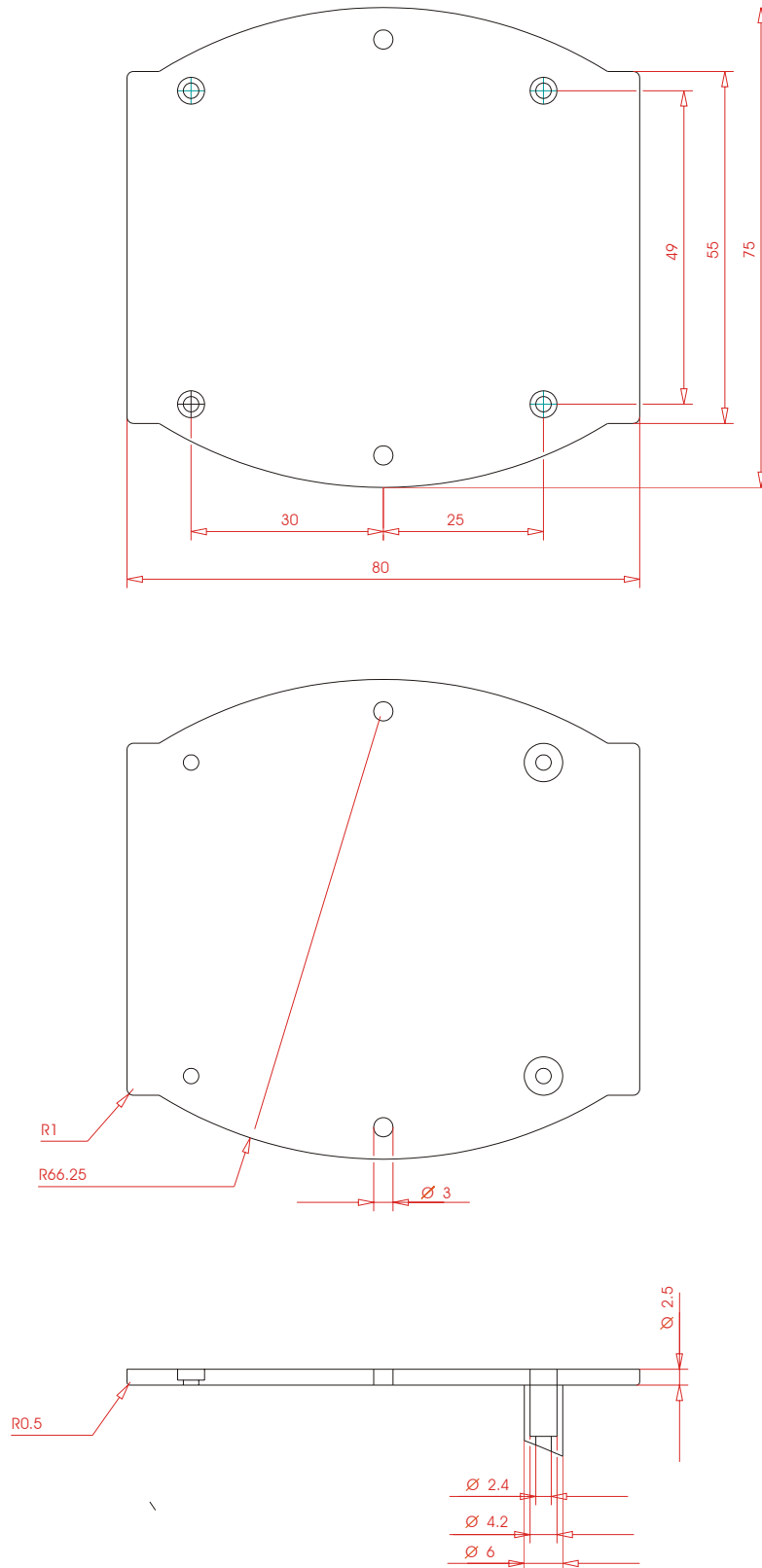

**Figure 19:** Mounting cradle of the STEPP II

## 9 RF Exposures

This device contains 850/1800/1900 MHz GSM/GPRS functions that are operational in these frequencies respectively.

The STEPP II/56 terminal contains 1800 MHz GSM functions that is not operational (must not be used) in U.S. Territories. This filing is only applicable for 850MHz GSM/1900 MHz PCS operations, whereby only these frequencies (850MHz GSM/1900 MHz PCS) are possible to be used in U.S. Territories.

The external antennas used for this mobile transmitter must provide a separation distance of at least 20 cm from all persons and must not be co-located or operating in conjunction with any other antenna or transmitter.

### **Statement according to FCC part 15.19:**

This device complies with Part 15 of the FCC Rules. Operation is subject to the following two conditions:

- (1) this device may not cause harmful interference, and
- (2) this device must accept any interference received, including interference that may cause undesired operation.

### **Statement according to FCC part 15.21:**

Modifications not expressly approved by this company could void the user's authority to operate the equipment.

### **Statement according to FCC part 15.105:**

**NOTE:** This equipment has been tested and found to comply with the limits for a Class B digital device, pursuant to Part 15 of the FCC Rules. These limits are designed to provide reasonable protection against harmful interference in a residential installation. This equipment generates, uses and can radiate radio frequency energy and, if not installed and used in accordance with the instructions, may cause harmful interference to radio communications.

However, there is no guarantee that interference will not occur in a particular installation. If this equipment does cause harmful interference to radio or television reception, which can be determined by turning the equipment off and on, the user is encouraged to try to correct the interference by one or more of the following measures:

- Reorient or relocate the receiving antenna.
- Increase the separation between the equipment and receiver.
- Connect the equipment into an outlet on a circuit different from that to which the receiver is connected.
- Consult the dealer or an experienced radio/TV technician for help

## 10 Appendix

### 10.1 Schematics

The figures below illustrate the recommended schematics for the connection of the 16-pin Molex and 15-pin AMP connectors.

#### 10.1.1 Installation guidance for 16-pin Molex connector

On the top of the schematic the corresponding pin out of the 16-pin Molex connector can be found.

A general purpose terminal providing multiple digital and analogue inputs as well outputs for a variety of uses.

The STEPP II comprises 7 inputs, 4 outputs and 2 analog inputs.

Of the 7 inputs, 4 inputs are free available for the user application. Three of the inputs are predefined by the manufacturer as below:

- 1 x Power supply → which has to be connected to the vehicle battery (clamp 30).
- 2 x Ignition lines → from them one can be connected to the vehicle starter lock (clamp 15). It can be used to trigger an alarm SMS when clamp 15 (ignition contact) of the vehicle is closed (engine of vehicle started). These pins are not provided to switch ON/OFF the STEPP II terminal.

4 digital inputs can be used to trigger any alarm type (SMS, voice or data), i.e. they can be connected to the car alarms or to a door switch, etc.

4 digital outputs are useful to switch remotely ON/OFF an external device. A schematic below in this section shows how digital inputs/outputs can be used.

Note that all provided outputs have to be used on the same level to the operating voltage ( $V_{VC+}$ ).

Ensure that the operating voltage ( $V_{VC+}$ ) of the terminal and external power source (i.e. car battery) incorporates a protection circuit against over voltage, which has to be limited to 2 A at +10.8 ... +32 VDC. See circuit diagram below.

A microphone can be connected to pin 1 and pin 3 of the 16-pin Molex connector. The figure 20 shows an example for the installation of the STEPP II-I/O's in a motor vehicle.

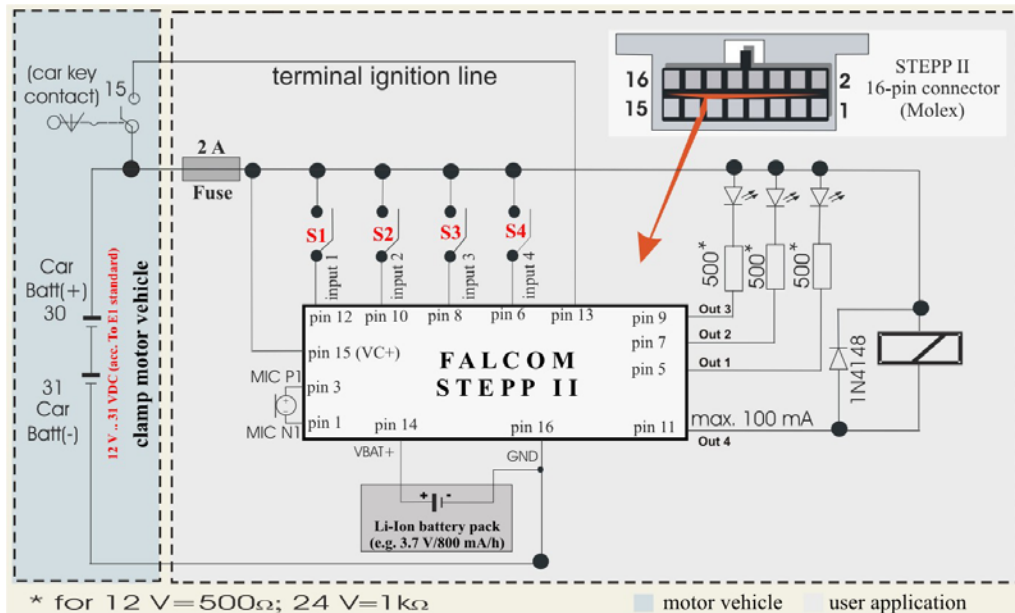

Figure 20: Schematic example of installation guidance

**10.1.2 Installation guidance for 15-pin AMP connector**

Figure 21 shows an example of an installation that enables voice communication. STEPP II supports two differential microphone inputs and two differential speaker outputs. The integrated amplifier allows direct connection of a Hands-Free-set to Pin 9 and Pin 10.

Please, note that the integrated audio interfaces are predefined on the embedded internal firmware as voice and alarm channels, where by pins (7, 8, 9 and 10) provided on the 15-pin AMP connector support voice channel and pins (1 and 3) provided on the 16-pin Molex connector support alarm channel.

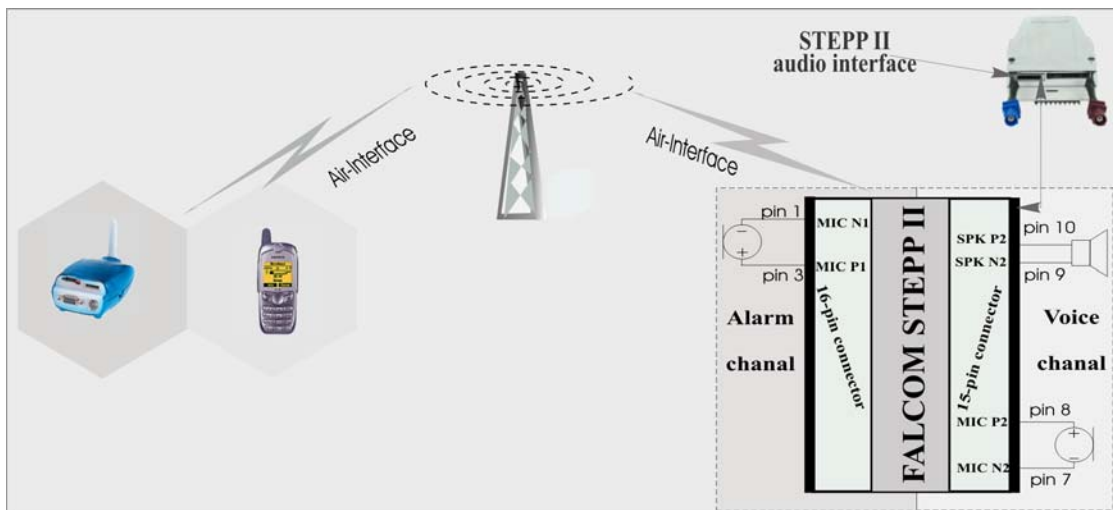

Figure 21: Possible installation for enabling voice connection.

**Voice channel**

The voice channel allows you to conduct a normal telephone conversation with the FALCOM STEPP II. For this, FALCOM STEPP II operates in Hands-Free mode. Requirements are to connect a loud speaker to the pins 9 and 10 and a Hands-Free microphone to the pins 7 and 8 of the FALCOM STEPP II 15-pin connector. FALCOM STEPP II will automatically answer an incoming call after the second or third ring.

**Alarm channel**

The alarm channel allows you to establish a voice call (listen-in mode) to the FALCOM STEPP II, without activating the loud speaker interface on the FALCOM STEPP II. In this case, connect a Hands-Free microphone to pins 1 and 3 of the FALCOM STEPP II 16-pin connector.