



# OWNER'S OPERATING MANUAL

## **FN Series™ Rackmount UPS Plus®**

Parallel or N+1 Redundant 3kVA to 24kVA

Hardwire models with a 208-240Vac Input and 120Vac & 240Vac Outputs

### **Uninterruptible Power Supply Models:**

**FN3KRM-2, -2TX & -2TXI**

**FN4KRM-2, -2TX & -2TXI**

**FN5KRM-2, -2TX, & -2TXI**

**FN6KRM-2, -2TX & -2TXI**



---

FALCON® Electric, Inc., 5106 Azusa Canyon Rd., Irwindale, California 91706, (626) 962-7770, Fax (626) 962-7720, Email: [sales@falconups.com](mailto:sales@falconups.com)

2009 Falcon® Electric Inc. All rights reserved.

All other brand names and trademarks are the property of their respective owners.

The information stated in this document is subject to change without notice. 2009-9-16

Falcon®, Falcon® Electric, FN and UPS Plus logos are registered trademarks of Falcon Electric, Inc.

## TABLE OF CONTENTS

FN Rackmount Series Parallelable and N+1 Redundant UPS Features..	3
FN -2TXI Double-Conversion On-line UPS Block Diagram.	3
Important Safety Instructions (READ FIRST)	4
<b>Chapter 1. Introduction</b>	
1.1 Manual Overview.	5
1.2 Brief FN Overview.	5
<b>Chapter 2. FN UPS Circuit Descriptions</b>	
Galvanically Isolated Output.	6
Input & Power Factor Correction	6
Power Factor Correction.	6
DC/DC Converter.	6
DC/AC Inverter	6
Battery Packs	6
Internal Battery Charger	6
Static Bypass Function.	7
Automatic Bypass Transfers	7
Output Filter	7
<b>Chapter 3. Unpacking the UPS and Battery Bank</b>	
3.1 Unpacking Instructions	8
<b>Chapter 4. Pre-installation Details</b>	
4.1 Floor Loading Requirements	9
4.2 UPS Input Power Requirements.	10
4.3 UPS Input/Output Requirements	10
4.4 UPS Output Rating Details	11
4.5 FN System Rear Panel Overview	11
4.6 Hardwire Terminal Block Wiring Details	12
4.7 UPS Rear Panel Details	12
4.8 System Installation Wiring Diagram, Single UPS Unit	13
4.9 System Installation Wiring Diagram, Multiple Parallel UPS Units.	13
4.10 UPS & Transformer Module Communications Bus Cabling..	13
4.11 External Battery Charger Option Installation	14
<b>Chapter 5. Displays &amp; Controls</b>	
5.1 Control Button and LCD Locations	15
5.2 Control Button Operation	15
5.3 LED Display Modes	16
5.4 LCD Display Overview	17
5.5 LCD Icon Descriptions	17
5.6 Status & Error Code Descriptions	17
<b>Chapter 6. Operation</b>	
6.1 How to start up the UPS with utility power present.	19
6.2 How to start up the UPS without utility power present.	21
6.3 How to turn off the UPS inverter and place the UPS into bypass mode	21
6.4 How to completely shutdown the UPS	21
6.5 How to display Readings.	22
6.6 How to display Programmed Settings	24
6.7 How to change the Programmed Settings	27
6.8 How to use the Maintenance Bypass Switch	31
<b>Chapter 7. Communications</b>	
7.1 Advanced Communications Option Cards Available	32
7.2 RS-232 Port	32
7.3 Optional Remote Emergency Power Off	33
7.4 Optional Communications Interface Board Details.	33
<b>Chapter 8. Maintenance</b>	
1. UPS & Battery Care	35
2. Storing the UPS and Batteries	35
3. When to Replace Batteries	35
<b>Chapter 9. Parallel Mode Operation</b>	
9.1 How to configure FN models for Transformer Module, Parallel or N+1 Communications.	36
9.2 How to connect the FNB Battery Module to the UPS Module	37
<b>Chapter 10. Environmental</b>	
10.1 Recycling the Used Battery Packs	37
10.2 FCC Considerations	37
<b>Chapter 11. Technical Support</b>	38
Warranty.	39
Specifications	40-43

## FN Series™ Parallelable and N+1 Redundant UPS Features

- Parallel Mode and N+1 Redundant Mode Operation
- True Double Conversion On-Line Sinewave Design
- Output Galvanic Isolation
- LCD Display with Advanced Monitoring
- Remote Emergency Power Off (REPO) Option
- Input Power Factor Correction
- Wide Input Voltage Window
- Precision Output Voltage Regulation
- Superior Brownout, Surge and Transient Protection
- Frequency Converter Operation
- User-Replaceable and Hot-Swappable Battery Pack
- Optional Extended Battery Banks & Chargers
- RS-232, USB & Optional SNMP/HTTP Communications
- UPSilon UPS Monitoring & Management Software
- Two-Year Warranty

### FN -2TXI Model Double Conversion On-line UPS Block Diagram

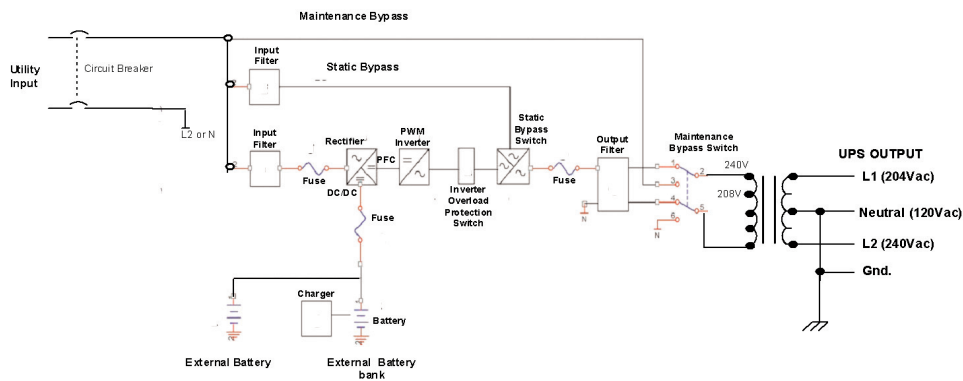

# IMPORTANT SAFETY INSTRUCTIONS, SAVE THESE INSTRUCTIONS

## RETAIN THIS USER MANUAL!

This manual contains important instructions which must be followed during the installation, operation and maintenance of the FN Series UPS, battery banks transformer box and options. **Please read all instructions before operating this equipment and save this manual for future reference.**

All of the models presented herein are designed for installation and use in a temperature-controlled environment, free of contamination.

**This UPS operates from utility power and contains a number of high current back-up batteries; this information is important to all personnel involved. Please read this manual first before continuing to unpack, install or operate this UPS.**

## STORAGE AND TRANSPORTATION

This UPS must be handled with care and given special attention due to the high amount of energy stored within its internal sealed, lead acid batteries. Please retain the UPS shipping container in the event the UPS needs to be returned for service. It has been designed to ship the UPS safely, without shipping damage.

## INSTALLATION

This UPS must be installed in a clean environment, free from moisture, flammable gases or fumes and corrosive substances. Operate the UPS in an indoor environment with an ambient temperature range of 32°F to +104°F (0°C to +40°C).

This UPS is designed for use with industrial, scientific or data processing class equipment.

**DO NOT USE TO POWER LIFE SUPPORT EQUIPMENT OR OTHER DESIGNATED “LIFE CRITICAL” APPLICATIONS.**

**The maximum UPS output load (in watts) must never exceed that shown on the UPS rating label. NEVER CONNECT equipment that could overload the UPS or demand half-wave rectification from the UPS, for example: electric drills, vacuum cleaners or hair dryers.**

Storing magnetic media on top of the UPS may result in data loss or corruption.

### **WARNING**

This UPS must be installed according to the instructions in this manual. Failure to do so could result in unsafe operation and could invalidate your warranty.

### **WARNING**

Once batteries have reached the end of their life, ensure they are disposed of properly.

**PLEASE REFER TO YOUR LOCAL LAWS AND REGULATIONS FOR BATTERY RECYCLING REQUIREMENTS. NEVER DISPOSE OF BATTERIES IN A LAND FILL.**

**Do not dispose of battery pack or batteries in a fire. The battery may explode. Do not open or mutilate the battery pack. Released electrolyte is harmful to skin and eyes. It may be toxic.**

### **WARNING**

A battery can present a risk of electrical shock and high short circuit current. The following precautions should be observed when working on batteries:

- \* Remove watches, rings, and other metal objects.
- \* Use tools with insulated handles.

## **1.0 INTRODUCTION**

### **Manual Overview**

This user manual has been written to provide basic information about Falcon FN Series -2TXI rackmount models. The FN Series is a rugged, double conversion, "on-line" UPS. It has galvanic output isolation configured for single or dual voltage output(s). The FN Series provides continuous power conditioning and accepts a wide range input voltage, while providing tight voltage regulation and a true sinewave output. The FN Series UPS is specifically designed to protect sensitive computers, laboratory and industrial equipment against the widest range of power problems. These problems include power failures, voltage sags, voltage surges, brownouts, utility line noise, high voltage spikes, frequency variations, common mode noise, switching transients, and harmonic distortion.

This manual also details unpacking, unit installation and the major features of the FN Series UPS, in addition to detailed UPS operation, configuration and troubleshooting information.

The specifications section at the end of this manual provides detailed operating parameters and general information on approvals and certifications.

### **FN Rackmount Overview**

The Falcon FN Series UPS system consists of (1) 2U Rackmount UPS module, (1) 3U rackmount battery module and (1) 2U rackmount output isolation transformer module. An optional input isolation transformer module is also available. The modules are designed to be easily installed in a standard 19" equipment rack. The equipment rack must be equipped with hard mounted shelves to properly support the weight of the modules. The modules do not support the mounting of equipment slide rails.

The FN Series front panel features a graphical LCD display, providing detailed operational information at a glance. The display enables the user or field service engineer to easily monitor and troubleshoot localized power problems, in addition to UPS operation. UPS control and programming are easily accessed using pushbuttons located adjacent to the LCD display.

FN rackmount UPS, Battery and Transformer module rear panels have the following features and functions:

**a. Circuit Breakers.**

**b. Hardwire input/output terminal blocks.**

**c. Maintenance Bypass Switch**

The maintenance bypass switch is located behind a protective cover plate on the transformer box rear panel. The UPS must be placed into manual static bypass mode prior to switching the maintenance bypass switch.

**d. RS-232 Port** - This port may be used to provide communications between the UPS and a network server or other computer system. When used in conjunction with the supplied UPSilon software, remote UPS monitoring and control are facilitated. The software will automatically save all open computer files and initiate an unattended, orderly operating system shutdown in the event of a utility power outage. UPSilon supports most MS Windows and Linux operating systems. An optional UNIX version is available through Falcon at an additional cost.

**e. Two Communications Option Board Expansion Slots** - The slots support the installation of an optional SNMP/HTTP Agent or contact closure interface boards. The SNMP/HTTP Agent board is a TCP-IP addressable solution to remote UPS monitoring and management via LAN, WAN or the Internet. The agent board is supplied with client software that will remotely shut down multiple servers or computers through the Ethernet LAN. A CD containing software clients and a SNMP MIB II compliant MIB is provided that supports most popular operations systems.

**f. Two RJ45 connectors for connection of UPS parallel operation or remote maintenance**

**bypass interface cables.** Used when UPS and transformer modules, or multiple UPS systems are connected in parallel.

**WARNING: Only FN rackmount models of identical power ratings may be connected in parallel. For example, a FN3KRM-2TXI may only be connected in parallel with another FN3KRM-2TXI unit. The FN5KRM-2TXI may only be connected in parallel with another FN5KRM-2TXI. The same is true for the FN6KRM-2TXI model.**

**g. One Local Maintenance Bypass Switch.** The switch is located on the transformer module rear panel and provides a manual means of placing the UPS into bypass mode to allow for servicing to be performed on the UPS and battery modules.

## **2.0 FN RACKMOUNT UPS CIRCUIT DESCRIPTIONS**

### **Galvanically Isolated Output**

The FN -2TXI output isolation transformer module provides a galvanically isolated, 120/240Vac, hardwire output. To meet UL and code requirements, a dedicated electrical panel should be provided by your electrical contractor or electrician. The FN -2TXI output configuration can be configured for a 120Vac, 208, 220, 230, or 240Vac output. It may also be configured for a dual voltage or 120/240Vac split-phase hardwire output. This configuration allows for the use of a standard electrical panel and readily available branch rated circuit breakers. It also simplifies the distribution to 240Vac and 120Vac loads. The outputs of up to four FN -2TXI units may be connected in parallel. Please refer to pages 12-13 of this manual for wiring details.

Additionally, the FN galvanic output isolation in conjunction with a derived neutral greatly reduces common mode noise and ground loops.

### **Input & Power Factor Correction**

All FN rackmount models require a 2 wire plus ground type 208-240Vac power source, at 50 or 60Hz. Each UPS module input must be connected to a dedicated circuit having a branch rated circuit breaker. If multiple FN units are to be connected in parallel, care must be taken to verify the source electrical panel has enough capacity. It must be rated to supply the total input power requirements of all FN Series units being connected, including all optional extended battery chargers, in addition to any other circuits that may be connected to the panel. Please have your electrical contractor review the FN datasheet located at the end of this manual and perform a site survey several weeks in advance of the installation date.

While the FN Series UPS is operating from the utility power, its internal power factor correction circuit converts utility AC power into regulated DC power for inverter use. The circuit also corrects the input current to maintain the phase relationships between both current and voltage sine waveforms. This also minimizes the amount of current distortion that is reflected back to the utility line.

### **DC/DC Converter**

The DC/DC converter utilizes energy from the batteries and boosts up the DC voltage to a level required by the inverter. This allows the inverter to operate continuously at optimum efficiency and voltage. The converter incorporates a patented circuit which reduces the amount of ripple current and EMI interference to the battery, increasing the overall battery life.

### **DC/AC Inverter**

In utility mode operation, the inverter utilizes the regulated DC output and converts it back into clean, regulated sinewave AC power. When utility power fails, the inverter will receive its energy from the battery through the DC/DC converter. In both modes of operation, the UPS inverter is online and continuously generates clean, regulated AC output power to the load. The IGBT, PWM inverter is of a very robust design and produces a pure sinewave output with a +/-2% voltage regulation. Having a very low output impedance, it can supply the high current demands of high inrush and non-linear loads.

## **Battery Packs**

FN rackmount battery modules utilize flame retardant batteries. They consist of (20) 12V, 7AH valve-regulated, sealed lead acid (VRLA) batteries in each module (Yuasa NP7-12). See replacement instructions on page 34.

To maintain the optimum battery life, the UPS should be installed in an environment with an ambient temperature of 68°F to 77°F (20°C to 25°C). Due to the battery manufacturer specification, the FN Series UPS batteries may be operated at 32°F to 104°F (0°C - 40°C) , but battery life will be substantially reduced if continuously operated at the higher temperature levels. Optional extended battery modules and external battery charger modules are available through Falcon to extend the amount of battery runtime.

## **Internal Battery Charger**

The internal battery charger located inside the UPS module utilizes energy from the utility power source to continuously charge the UPS batteries. The charger operates in "constant power" mode. The UPS batteries are being charged whenever the UPS is plugged in, turned on and operating from utility power. The internal UPS battery charger output is rated at 1.9 amps.

## **Static Bypass Function**

*NOTE: Bypass power will only be available if the bypass input is connected at the time of UPS installation.*

A manual static bypass pushbutton is located on the FN front control panel. When the UPS is operating from utility in the normal utility mode on-line state, depressing this button will cause the UPS to transfer to bypass. Depressing the bypass button again will return the UPS to normal inverter operation.

## **Automatic Bypass Transfers**

The FN Series UPS module will automatically switch to bypass mode under the following conditions: To energize the connected load when the UPS is first turned on; encounters an overload; encounters an over temperature condition; or upon a UPS failure condition. Should any of these events occur, the UPS will automatically transfer to bypass mode, sound an audible alarm and provide a "bypass" indication on the UPS module LCD display.

## **Output Filter**

As with the input filter stage, the output filter maintains conducted (EMC) and RFI levels below FCC Class A limits.

### **3.0 UNPACKING THE UPS AND BATTERY BANK**

Due to their size and weight the FN rackmount UPS, battery and transformer modules are packaged inside shipping cartons that are secured to a shipping pallet. Removal of the UPS, transformer and battery bank modules should never be attempted by one person.

Upon unpacking the UPS, transformer or battery bank, verify the following items were shipped. Should you have not received any of the items listed below, please contact Falcon Electric Customer Service at 1-800-842-6940.

#### **FN Rackmount UPS Module**

Shipping pallet contents:

- (1) FN Rackmount UPS (verify model shipped)
- (1) RS-232 Cable
- (1) UPSilon Software CD
- (1) Software Interface Cable
- (1) Owner's Manual
- (1) Installation Kit

#### **FNBRM-1S7 Battery Module**

Shipping pallet contents:

- (1) FN Extended Battery Bank
- (1) Interface Cable
- (1) Installation Kit

#### **FNITRM-2 Rackmount Output Transformer Module**

- (1) Installation kit
- (2) UPS Communications Interface Cables

**NOTE: If multiple FN UPS units were received for connection in parallel, please verify that one parallel interface cable kit has been received for each FN Rackmount system unit received.**

### **3.1 Unpacking Instructions**

1. Cut the bands securing the protective carton and lift it off of the UPS, Transformer and battery modules in their shipping cartons. Due to the weight of the units, a second person will be required.
2. Remove the Individual modules from their shipping cartons. Take care to remove separate cables, software, hardware packages and any other items shipped with the modules.

**Note: The UPS or extended battery bank weighs over 100 pounds. It is not recommended that you attempt to lift and remove them from the shipping pallet without the proper equipment.**



## **4.0 PRE-INSTALLATION DETAILS**

Falcon Electric, Inc. is not responsible for shipping damage or for filing shipping damage claims. Visually inspect the equipment for freight damage. If any equipment has been damaged during shipment, retain the shipping pallet and packing materials for inspection by the carrier, and immediately file a claim for “shipping damage” with the carrier. If you discover damage after acceptance, file a claim for “concealed damage”.

To file a claim for shipping damage or concealed damage:

- a. YOU MUST file with the carrier within 15 days of receipt of the equipment;
- b. YOU MUST send a copy of the damage claim within 15 days to Falcon Electric, Inc.

### **WARNING**

The UPS, Transformer and Battery Modules are very heavy. Use the proper lifting equipment and take the proper precautions when lifting or moving them.

1. Always install the FN system indoors in a controlled environment.
2. Install the FN modules in a location with unrestricted airflow around the front and rear sides of the modules, away from water, flammable liquids, gases, corrosive, and conductive contaminants.
3. Maintain a minimum clearance of 4 inches in the front and rear of the UPS.
4. Maintain an ambient temperature range of 32°F to 104°F (0°C to 40°C). To assure the maximum life of the batteries, operation in an ambient temperature of 68°F to 77°F (20°C to 25°C) is recommended.

### **OPERATION IN TEMPERATURES ABOVE 77°F (25°C) WILL REDUCE BATTERY LIFE.**

5. The FN Series Rackmount system modules must be installed in a standard 19” equipment rack having hard mounted shelves under the modules to properly support their weight.
6. When selecting a suitable rack location for the UPS, Transformer and battery bank(s) always verify the floor loading capabilities:

## **4.1 Floor Loading Requirements**

**a. VERIFY THE FLOOR OR SUPPORTING SURFACE UNDER THE EQUIPMENT RACK IS RATED TO SUPPORT THE WEIGHT OF THE TOTAL WEIGHT OF THE RACK, THE FN MODULES AND ALL OTHER EQUIPMENT INSIDE THE RACK.**

**UPS Module:**

- (1) FN3KRM-2TXI or FN4KRM-2TXI or FN5KRM-2TXI or FN6KRM-2TXI = 53 lbs. (24 kg)
- (2) FN3KRM-2TXI or FN4KRM-2TXI or FN5KRM-2TXI or FN6KRM-2TXI = 106 lbs. (48 kg)
- (3) FN3KRM-2TXI or FN4KRM-2TXI or FN5KRM-2TXI or FN6KRM-2TXI = 159 lbs. (72 kg)
- (4) FN3KRM-2TXI or FN4KRM-2TXI or FN5KRM-2TXI or FN6KRM-2TXI = 212 lbs. (96 kg)

**Battery Bank Modules (for all FN Rackmount models)**

- (1) FNBRM-1S7 = 150 lbs. (68 kg)
- (2) FNBRM-1S7 = 300 lbs. (136 kg)
- (3) FNBRM-1S7 = 450 lbs. (204 kg)
- (4) FNBRM-1S7 = 600 lbs. (272 kg)

**Output Transformer Module (for all FN Rackmount models)**

- (1) FNITRM-2 = 91 lbs. (41 kg)
- (2) FNITRM-2= 181 lbs. (82 kg)
- (3) FNITRM-2= 272 lbs. (123 kg)
- (4) FNITRM-2= 362 lbs. (164 kg)

## **4.2 UPS Input Power Requirements**

### **a. VERIFY THE PROPER UPS INPUT POWER IS AVAILABLE (for each UPS installed)**

<b>FN3KRM-2TXI</b>	<b>Input</b>	<b>--</b>	<b>Hardwire, 208-240Vac, 50/60Hz, 20A, single-phase, 2 wire plus ground</b>
<b>FN4KRM-2TXI</b>	<b>Input</b>	<b>--</b>	<b>Hardwire, 208-240Vac, 50/60Hz, 30A, single-phase, 2 wire plus ground</b>
<b>FN5KRM-2TXI</b>	<b>Input</b>	<b>--</b>	<b>Hardwire, 208-240Vac, 50/60Hz, 30A, single-phase, 2 wire plus ground</b>
<b>FN6KRM-2TXI</b>	<b>Input</b>	<b>--</b>	<b>Hardwire, 208-240Vac, 50/60Hz, 40A, single-phase, 2 wire plus ground</b>

## **4.3 UPS Input/Output Requirements**

### **a. VERIFY THE INPUT AND OUTPUT WIRING REQUIREMENTS**

<b>FN3KRM-2TXI</b>	<b>Wiring Type</b>	<b>--</b>	<b>THHN, 600V, insulated solid copper wire</b>
	<b>Gage</b>	<b>--</b>	<b>Input, 12 awg. - Output, 10 awg.</b>
	<b>Terminal Block Screw Torque</b>	<b>--</b>	<b>20 inch-pounds</b>
	<b>Required Branch Rated input circuit breaker</b>	<b>--</b>	<b>20A (40A with 3 external battery charger module options installed)</b>
	<b>Required Branch Rated output circuit breaker</b>	<b>--</b>	<b>20A</b>
<b>FN4KRM-2TXI</b>	<b>Wiring Type</b>	<b>--</b>	<b>THHN, 600V, insulated solid copper wire</b>
	<b>Gage</b>	<b>--</b>	<b>Input, 10 awg. - Output, 8 awg.</b>
	<b>Terminal Block Screw Torque</b>	<b>--</b>	<b>20 inch-pounds</b>
	<b>Required Branch Rated input circuit breaker</b>	<b>--</b>	<b>30A (50A with 3 external battery charger module options installed)</b>
	<b>Required Branch Rated output circuit breaker</b>	<b>--</b>	<b>30A</b>
<b>FN5KRM-2TXI</b>	<b>Wiring Type</b>	<b>--</b>	<b>THHN, 600V, insulated solid copper wire</b>
	<b>Gage</b>	<b>--</b>	<b>Input, 10 awg. - Output, 8 awg.</b>
	<b>Terminal Block Screw Torque</b>	<b>--</b>	<b>20 inch-pounds</b>
	<b>Required Branch Rated input circuit breaker</b>	<b>--</b>	<b>30A (50A with 3 external battery charger module options installed)</b>
	<b>Required Branch Rated output circuit breaker</b>	<b>--</b>	<b>30A</b>
<b>FN6KRM-2TXI</b>	<b>Wiring Type</b>	<b>--</b>	<b>THHN, 600V, insulated solid copper wire</b>
	<b>Gage</b>	<b>--</b>	<b>Input, 8 awg. - Output, 4 awg.</b>
	<b>Terminal Block Screw Torque</b>	<b>--</b>	<b>25-30 inch-pounds</b>
	<b>Required Branch Rated input circuit breaker</b>	<b>--</b>	<b>40A (60A with 3 external battery charger module options installed)</b>
	<b>Required Branch Rated output circuit breaker</b>	<b>--</b>	<b>40A</b>

## 4.4 UPS Output Rating Details

- a. **VERIFY THE LOAD TO BE CONNECTED DOES NOT EXCEED THE UPS OUTPUT RATING** for the single or combined paralleled UPS units.

(1) FN3KRM-2TXI	Not N+1	Hardwire, 120/240Vac, 2,100W, split-phase, 3 wire plus ground
(2) FN3KRM-2TXI	Not N+1	4,200W
	N+1	2,100W
(3) FN3KRM-2TXI	Not N+1	6,300W
	N+1	4,200W
(4) FN3KRM-2TXI	Not N+1	8,400W
	N+1	6,300W
1) FN4KRM-2TXI	Not N+1	Hardwire, 120/240Vac, 2,800W, split-phase, 3 wire plus ground
(2) FN4KRM-2TXI	Not N+1	5,600W
	N+1	2,800W
(3) FN4KRM-2TXI	Not N+1	8,400W
	N+1	5,600W
(4) FN4KRM-2TXI	Not N+1	11,200W
	N+1	8,400W
(1) FN5KRM-2TXI	Not N+1	Hardwire, 120/240Vac, 3,500W, split-phase, 3 wire plus ground
(2) FN5KRM-2TXI	Not N+1	7,000W
	N+1	3,500W
(3) FN5KRM-2TXI	Not N+1	10,500W
	N+1	7,000W
(4) FN5KRM-2TXI	Not N+1	14,000W
	N+1	10,500W
(1) FN6KRM-2TXI	Not N+1	Hardwire, 120/240Vac, 4,200W, split-phase, 3 wire plus ground
(2) FN6KRM-2TXI	Not N+1	8,400W
	N+1	4,200W
(3) FN6KRM-2TXI	Not N+1	12,600W
	N+1	8,400W
(4) FN6KRM-2TXI	Not N+1	16,800W
	N+1	12,600W

## 4.5 FN Rackmount System Rear Panel Overview

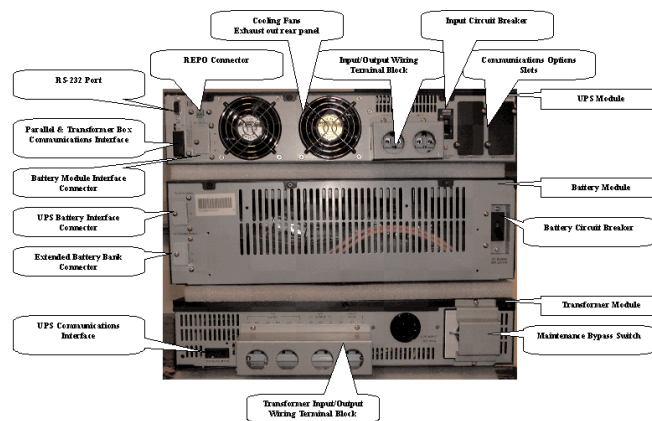

#### 4.6 Output Transformer Module Hardwire Terminal Block Wiring Details

1	2	3	4	5	6	7	8	9	10	11	12
Isolated Output to Load						Input From UPS Output			Utility (MBS input)		
G3 Ground	L2	L1	L2	L1	L1	G2 Ground	L2 (N)	L1	G1 Ground	L2	L1
	0	120Vac	0	120Vac	88Vac		208-240Vac			208-240Vac	

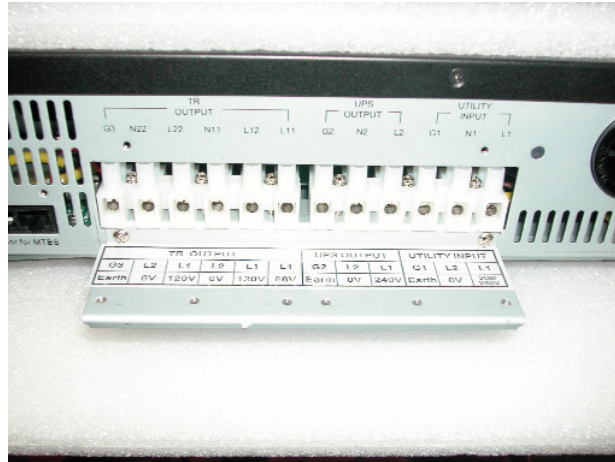

#### 4.7 UPS Module Hardwire Terminal Block Wiring Details



G2	N22	L21	G1	N1	L12
OUTPUT			INPUT		
Ground	L2	L1	Ground	L2	L1
	208-240Vac			208-240Vac	

To Transformer Box Input

From The Utility Source & To Transformer Module MBS Input

### 4.8 System Installation Wiring Diagram (single rackmount UPS system)

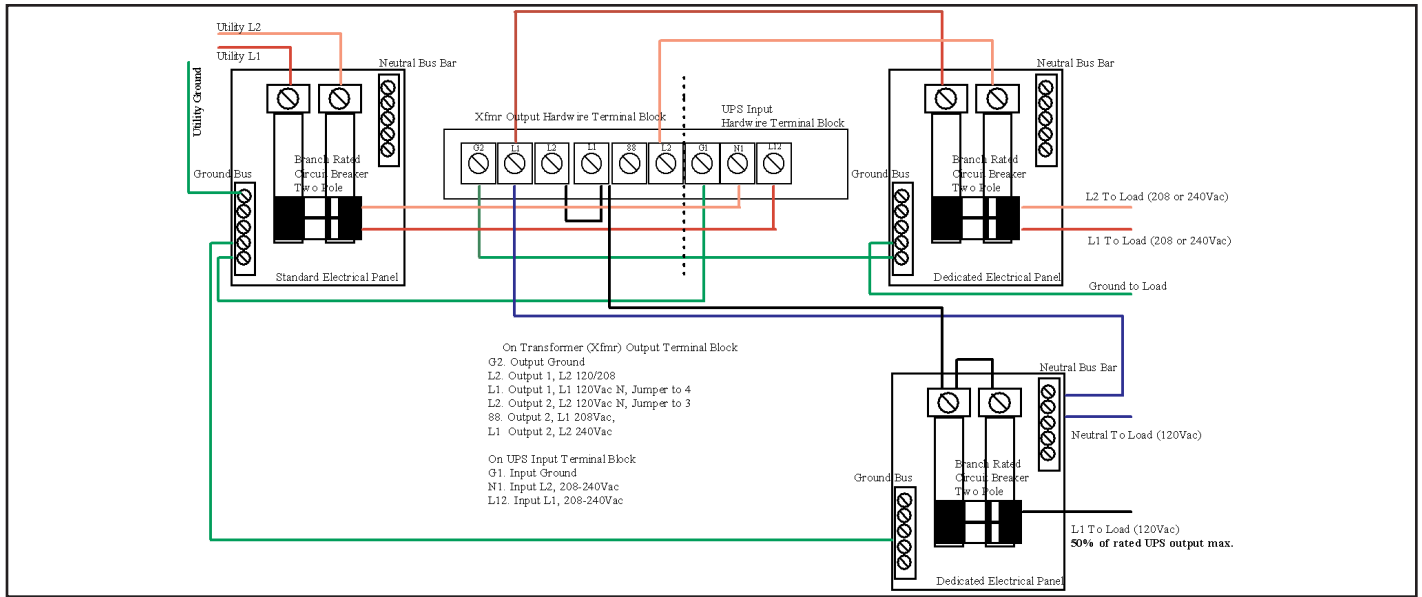

### 4.9 System Installation Wiring Diagram (typical multiple parallel UPS units, Rackmount)

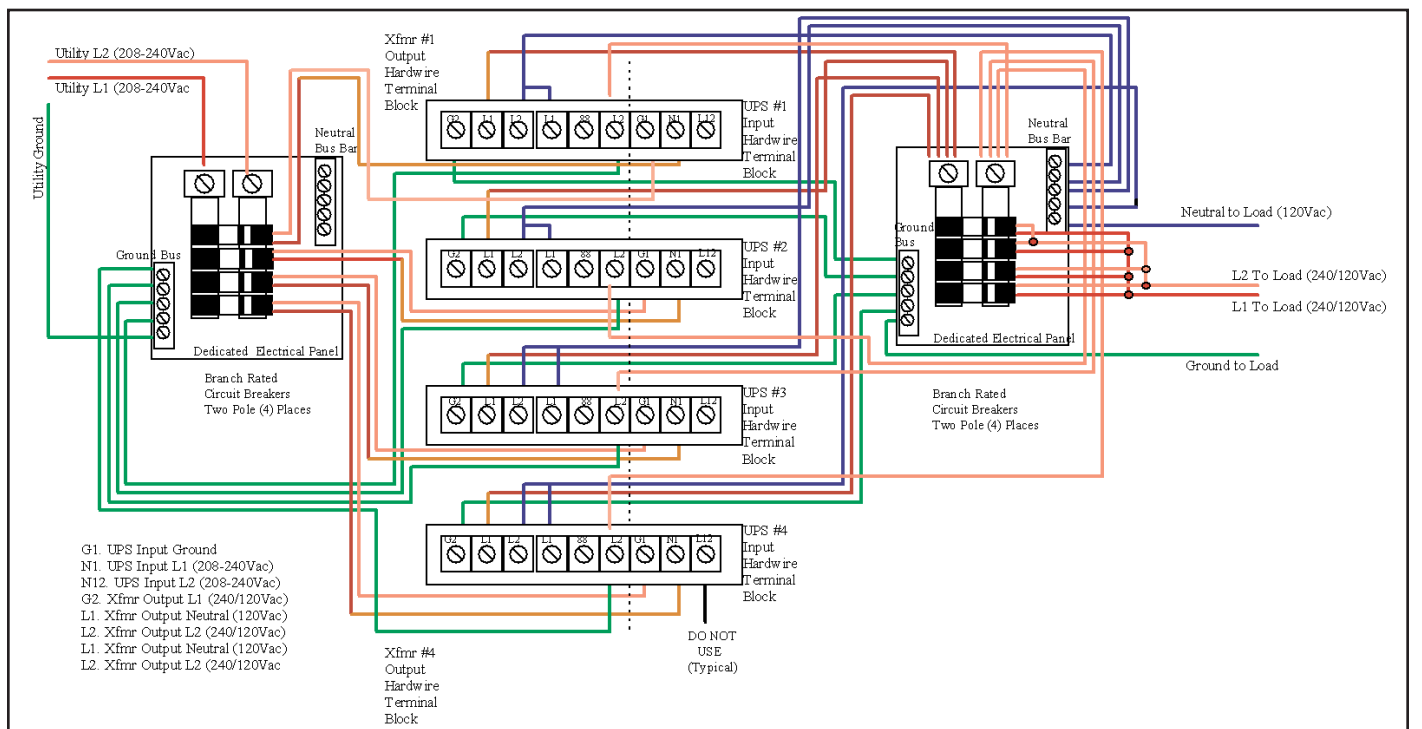

### 4.10 UPS & Transformer Modules Communications Bus Cabling

Use one UA88385 parallel communications bus cabling kit for each UPS to be connected to the system output transformer module or to paralleled UPS systems. Connect the supplied cables as shown below. Note the first and last connectors on the first and last UPS are connected using the longer of the supplied cables. Switch on the termination resistor dip switch next to the long cable. For the transformer module, daisy chain the cables from the UPS to the transformer module in a similar manner using the communications connectors located on the transformer module rear panel.

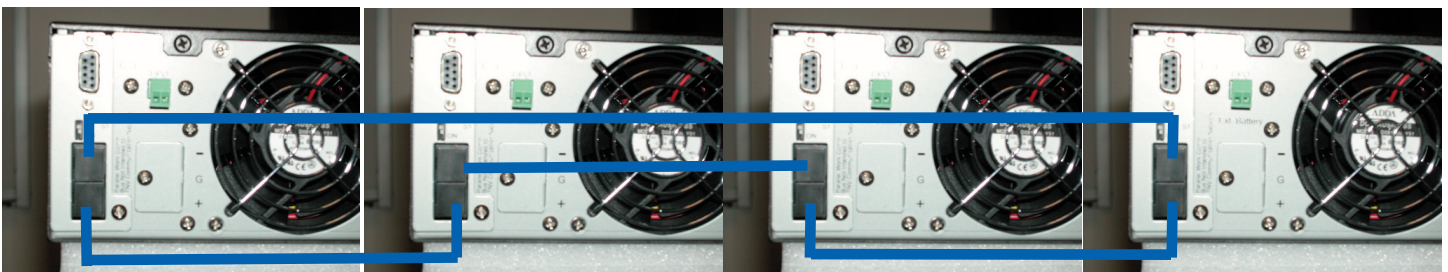

## 4.11 External Battery Charger Option Installation Wiring Detail (Typical UPS unit with optional FN6KBC-5A-2, for use with external battery banks only)

### FN6KBC-5A-2 5 Amp External Battery Charger Module



FN6KBC-5A-2 Battery Charger Module Terminal Block Wiring Details

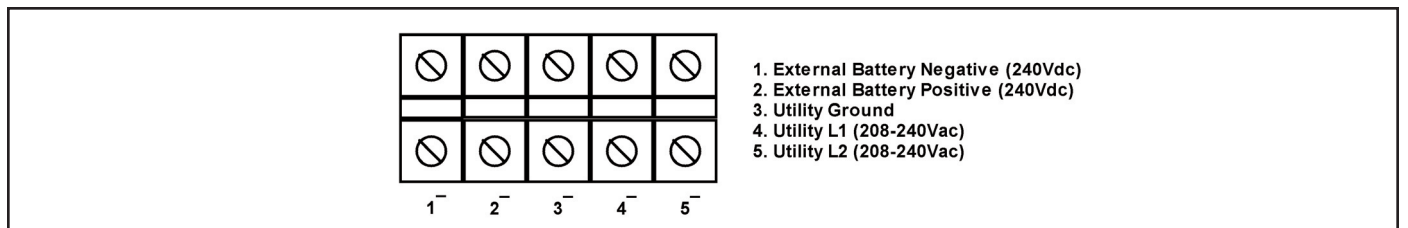

Battery Charger Module/UPS System Wiring Diagram

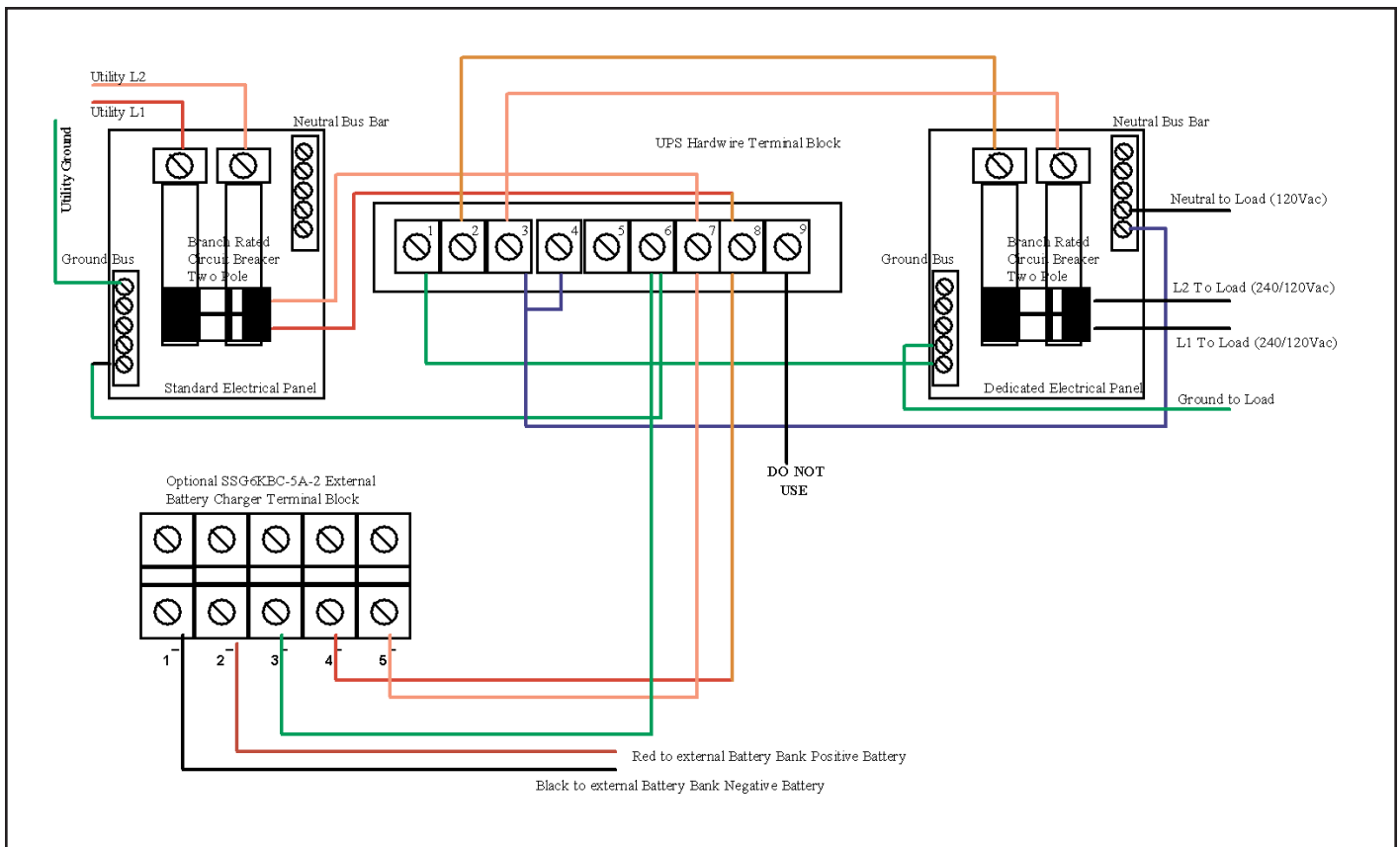

## 5.0 DISPLAY & CONTROLS

The pictures below outline the various control panel, LED and LCD functions and locations.

### 5.1 Control Button and LCD Locations

1. LCD Display
2. N+1 Status LED
3. Utility Status Indicator LED
4. Bypass Input Status LED
5. UPS On / Alarm Silence Control Button
6. Previous Page / Change Setting Button
7. Confirm Button
8. Next Page Button
9. UPS Off / Bypass Button
10. Function Button
11. Economy/Green Mode Status LED
12. UPS Alarm LED

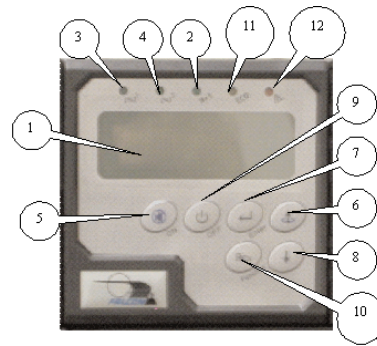

### 5.2 Control Button Operation



#### On/Alarm Silence Button

1. When utility power is present and the UPS input circuit breakers are in the “On” position, depressing and holding this button for 5 seconds will turn on the UPS.
2. When utility power is not present or the UPS input circuit breaker is in the “Off” position, depressing and holding this button for 5 seconds will initiate a preliminary startup sequence. When “Off” or “BPS” is displayed on the LCD, depressing the “On” button again for 6 seconds will start up the UPS in battery mode (cold start).
3. When the UPS is in utility or battery mode, depressing this button will silence any audible alarms.



#### Off/Bypass Button

1. When the UPS is operating in utility or battery mode, depressing and holding this button until an audible beep is sounded will leave the load powered in bypass mode. To completely shut down the UPS and connected load, press the Off/Bypass button until “Off” is displayed on the LCD, and then turn off the UPS and Bypass input circuit breakers. The UPS will shut down in about one minute.



#### Function Button

1. When the UPS is operating in utility or battery mode, depressing the Function Button will switch the LCD to display the “Programmed Parameter” settings. When in this mode, depressing the “Next Page” button will display the next programmed parameter setting. Repeatedly depress the “Next Page” button to display all of the programmed parameter settings.

#### Control Panel

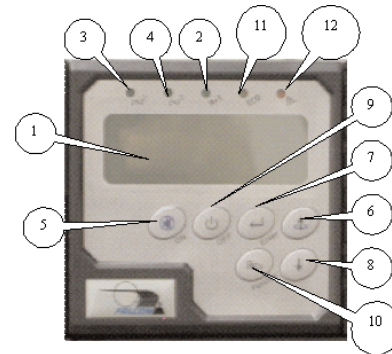

2. When the LCD is in the “Display Programmed Settings” mode, depressing the Function Button will return the LCD to normal mode.

The LCD display will also return to “Normal Mode” automatically after 30 seconds of button inactivity.



#### Previous Page/Change Setting Button

1. When the LCD display is in “Normal Mode”, repeated pressing of this button will sequence up through the input/output/battery parameters and readings will be displayed.
2. When in “Programming Mode”, pressing this button will change the selected parameter setting. The new setting will be displayed on the LCD Measurement display.



### Next Page Button

1. When the LCD display is in “Normal Mode”, repeated pressing of this button will sequence down through the input/output/battery parameters and readings.
2. When the UPS is displaying “OFF” or “BPS”, depressing the “Next Page” and “Function” buttons at the same time will place the UPS into “Programming Mode”. Refer to the “How to Change the Programmed Settings” section of this manual for more details.
3. When in “Programming Mode”, repeated pressing of this button will sequentially select the various programmable parameters. Refer to page 27, “How to Change the Programmed Settings” section of this manual for more details.



### Confirm Button

1. When in “Programming Mode” and prompted on the LCD display to SAVE settings, pressing this button will save all changed parameters.

## 5.3 LED Display Modes



**Utility (AC Source 1) UPS Input Power Present LED (Green)** -- Indicates utility power is present and the UPS input circuit breakers is turned on. If the utility voltage is out of tolerance the LED will turn off.

**Bypass (AC Source 2) Bypass Input Power Present LED (Green)**-- Indicates bypass power is present and the Bypass circuit breaker is turned on. If bypass power is out of range, the LED will turn off.

**N+1 Mode Enabled (Green)** - Indicates multiple UPS units are connected in parallel and have been properly configured and programmed for Parallel N+1 mode operation.

**Economy/Green Mode Enabled (Yellow)** -- Indicates Economy/Green mode has been enabled.

**Alarm Condition Present (Red)** -- Indicates the UPS in an alarm condition.



## 5.4 LCD Display Overview

### LCD Display

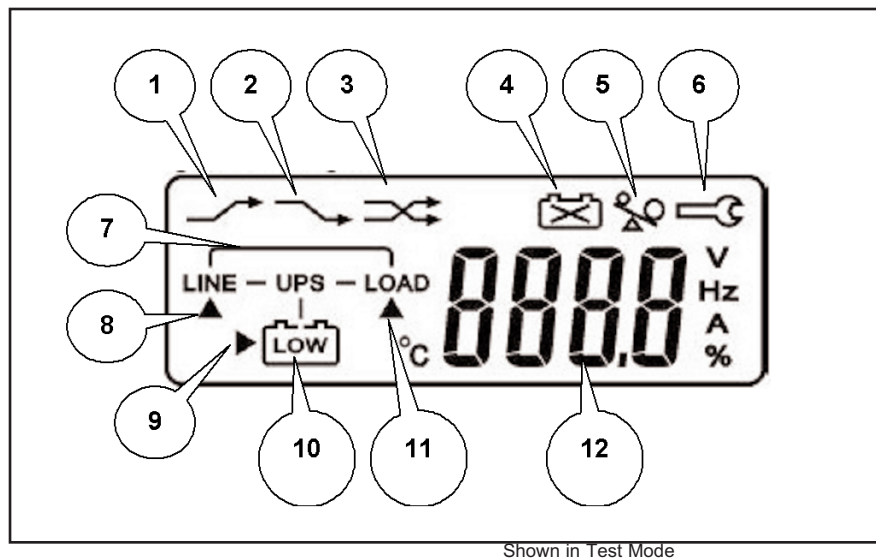

## 5.5 LCD Icon Descriptions

1. Bypass input is out of tolerance, UPS failed to transfer to bypass, or bypass input is out of tolerance when the UPS is in Economy/Green Mode.
2. Utility loss or the utility input is out of tolerance.
3. UPS lost inverter output and transferred to bypass.
4. Battery voltage is out of tolerance, or defective batteries.
5. The UPS output is overloaded.
6. The UPS is presently in maintenance mode.
7. MIMIC Display showing Line, UPS, Battery and Load. When referenced in conjunction with arrows 8, 9 and 11, it defines the operational state of the UPS. They also indicate the source of the input/output/battery parameter readings displayed on the Measurement Display (12).
- 8, 9 & 11. MIMIC display and Measurement location indicators.
10. Battery and Low Battery Icons. The battery icon is displayed as part of the MIMIC display. In the event of a utility loss that depletes that battery charge, the Low Battery icon is displayed until the batteries have recharged to a reasonable level. In the event of a complete battery discharge, the low battery icon will be displayed along with an audible alarm. When the batteries have recharged to a reasonable level, the normal battery icon will be displayed.
12. Measurement Display. The Measurement display is used to show the input/output/battery readings, program mode settings, status and error codes.

## 5.6 Status and Error Code Descriptions

- OFF or BPS-- Displayed when the UPS is turned off with the "Off" button, EPO or remote shutdown.
- EPO -- When an optional EPO communications board is installed, EPO is displayed alternately with the OFF or BPS message, after an EPO signal has been applied to the EPO interface connector. After an EPO condition, the UPS input circuit breaker must be turned off and the "Off" button must be depressed twice for 5 seconds to reset the UPS prior to turning the UPS and Bypass input circuit breakers back on.

- Er04 -- Error code 04 indicates the UPS inverter has malfunctioned. Contact Falcon Service.
- Er05 -- Error code 05 indicates the UPS batteries are weak or dead and must be replaced. Call Falcon Service upon receiving the message for further instructions.
- Er06 -- Error code 06 indicates the UPS output has a short circuit connected to it. Remove the connected equipment load from the UPS output and restart the UPS. If the shorted output condition is corrected, determine the location of the shorted wiring or equipment.
- Er07 -- EPO Mode.
- Er08 -- DC Bus high voltage level out of specification. Contact Falcon Service.
- Er09 -- DC Bus low voltage level out of specification. Contact Falcon Service.
- Er10 -- Error code 10 indicates the UPS inverter has encountered an over-current condition. This could indicate the connected equipment exceeds the output rating of the UPS. Disconnect some of the connected equipment in an attempt to correct the condition.
- Er11 -- Error code 11 indicates the UPS is in an over-temperature condition. Verify the ambient operating temperature is not too high. Verify the UPS cooling fan operation.
- Er12 -- Error code 12 indicates the UPS output is overloaded, similar to error code 10. This could indicate the connected equipment exceeds the output rating of the UPS. Disconnect some of the connected equipment in an attempt to correct the condition.
- Er13 -- Battery charger malfunction. Contact Falcon Service.
- Er14 -- Cooling fan failure. Contact Falcon Service.
- Er15 -- Maintenance bypass initiated improperly. Refer to page 31, Maintenance Bypass section.
- Er18 -- Internal software error, UPS programming reset to default values.
- Er22 -- Static bypass malfunction. Contact Falcon Service.
- Er24 -- Fixed 50 or 60Hz output mode programmed without turning off the bypass input circuit breaker. Should a fixed 50 or 60Hz output be desired, turn the bypass input circuit breaker off. To clear error code 24, startup the UPS with the Bypass input circuit breaker turned off.
- Er26 -- PFC over-current condition. Verify the UPS output is or has been overloaded.
- Er28 -- The UPS output has experienced a 120% overload in bypass for over 2 minutes. Bypass has been shutdown.
- Er29 -- The battery charger is overcharging the batteries. Contact Falcon Service.
- Er\*\* -- Other error code, consult with Falcon Service.

## 6.0 OPERATION

The following sections outline the operation and programming of the FN -2TXI UPS models. Please read and understand them completely prior to connecting any equipment to the UPS output.

### 6.1 How to start up the UPS with utility power present

1. Verify the UPS input wiring is correct and connected to a live circuit.
2. Turn on the UPS and Bypass input circuit breakers located on the UPS rear panel, and the following LCD Display will be displayed. **The UPS output will be immediately turned on, with the UPS in bypass mode.**

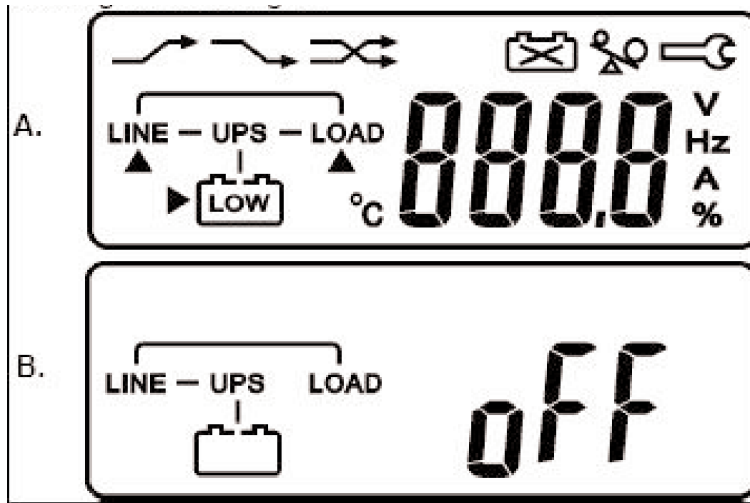

Display A is an LCD test display and is shown for about 3 seconds after the input circuit breaker is turned on.

Next, display B is shown (OFF or BPS displayed). The UPS is OFF with the load supported by the bypass output. The UPS will remain in this state until the "On" button is depressed. When the UPS is turned off using the "Off" button, it will return to this state until the input circuit breaker is turned off.

3. Depress the "On" button for 3 seconds until two audible beeps are sounded.
4. The UPS fans will turn on and the following LCD display will be shown:

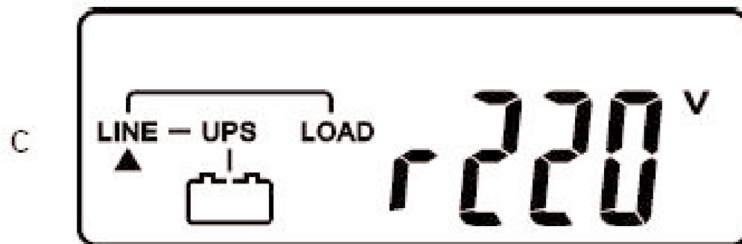

Note the MIMIC portion of the display with the arrow under the line and the input voltage is displayed.

The UPS will sound two short beeps continuously until the following is displayed.

**NOTE: Always allow the UPS to charge its batteries for 8 hours prior to use.**

5. The UPS will now sequence up to on-line mode and display the following:

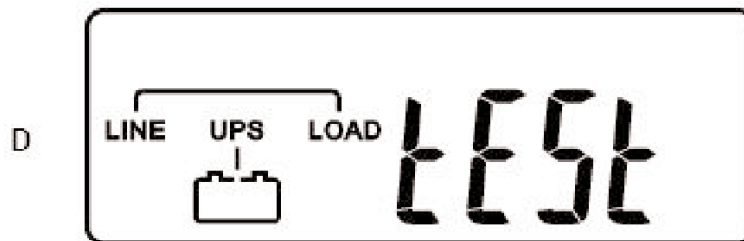

The UPS initiates a self-test.

Go to the next page.

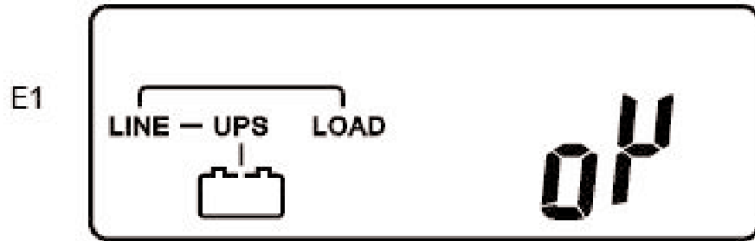

If the UPS passes the self-test, "OK" is displayed.

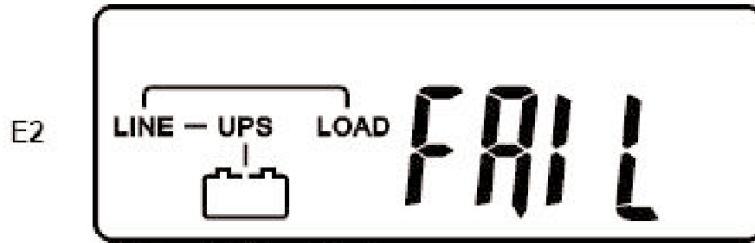

If the UPS fails the self-test, "FAIL" is displayed alternately with an error code. Please note the error code and contact Falcon Service.

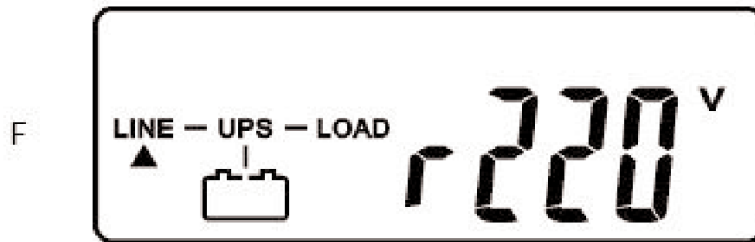

The UPS is now turned on and in on-line inverter mode. Using an AC volt meter, verify the UPS input voltage measurement.

## 6.2 How to start up the UPS without utility power present (Cold Start)

1. Press the “On” button for 6 seconds to awaken the UPS. The UPS will beep twice and display G below. Immediately upon G being displayed, press the “On” button for another 6 seconds. The UPS will beep twice again and sequence through H and I.

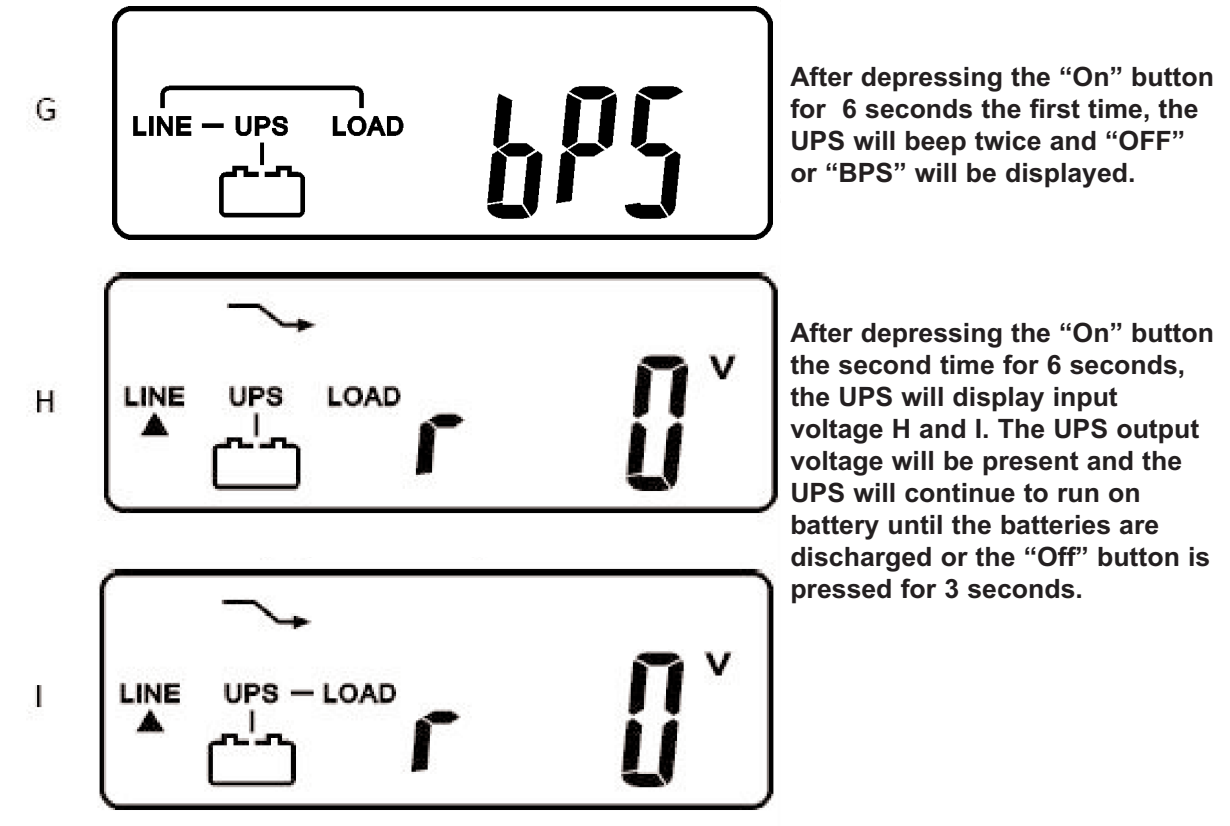

## 6.3 How to turn off the UPS inverter and place the UPS into bypass mode

1. While the UPS is operating in utility, inverter or battery mode, depress the “Off” button until the UPS sounds two audible beeps. The UPS will switch to static bypass and turn off the inverter. The LCD will display “OFF” or “BPS”. The connected load will now be powered directly from the utility source. The UPS will continue to operate in bypass mode until:
  - a. The “On” button is depressed for three seconds, which will return the UPS to normal inverter mode operation.
  - b. The UPS and Bypass Input circuit breakers are turned off, which will shut down the UPS and the connected load completely.

## 6.4 How to completely shutdown the UPS

1. While the UPS is operating in utility, inverter or battery mode, depress the “Off” button until the UPS sounds two audible beeps. The UPS will switch to static bypass and turn off the inverter. The LCD will display “OFF” or “BPS”.
2. Turn off the UPS and Bypass input circuit breakers, which will shutdown the UPS and the connected load completely.

Note, the UPS may continue to run for 30 seconds to one minute prior to turning off.

## 6.5 How to display readings

1. The bypass input voltage is displayed immediately after the UPS and Bypass circuit breakers are turned on and has sequenced up to inverter mode as shown in I1. Depressing the "Next Page" button will change to display the utility frequency as shown in J below.

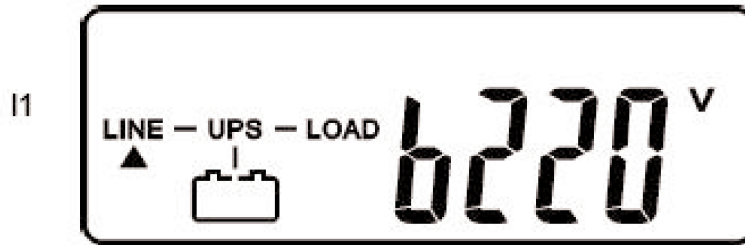

The "b" denotes the reading is for the bypass. The arrow under the LINE indicates the reading is for the bypass input voltage.

Depress the "Next Page" button.

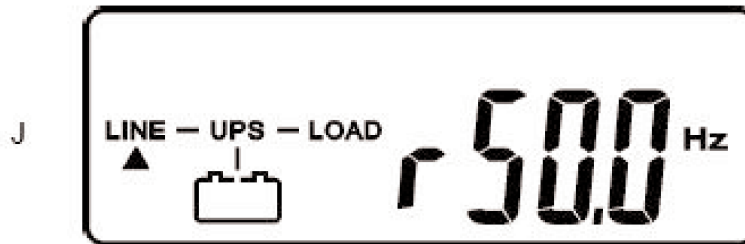

The "r" denotes the reading is for utility. The arrow under the LINE indicates the reading is for the utility frequency.

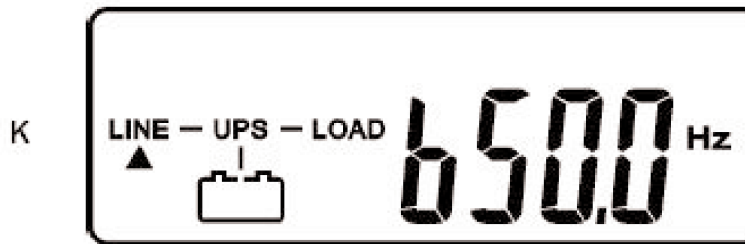

Depress the "Next Page" button.

The "b" denotes the reading is for the bypass.

Depress the "Next Page" button.

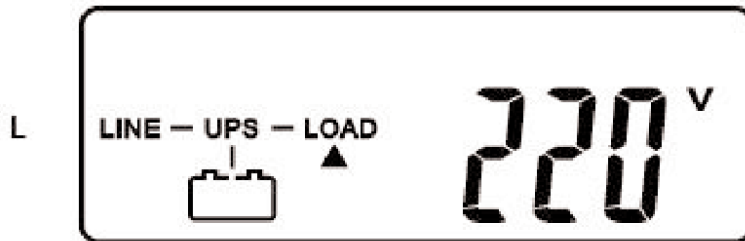

The arrow under the LOAD indicates the reading is for the UPS output voltage.

Depress the "Next Page" button.

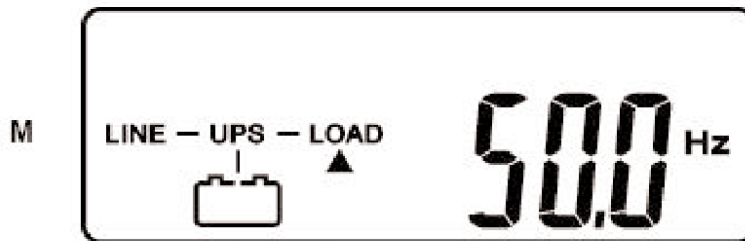

The arrow under the LOAD indicates the reading is for the UPS output frequency.

Depress the "Next Page" button.

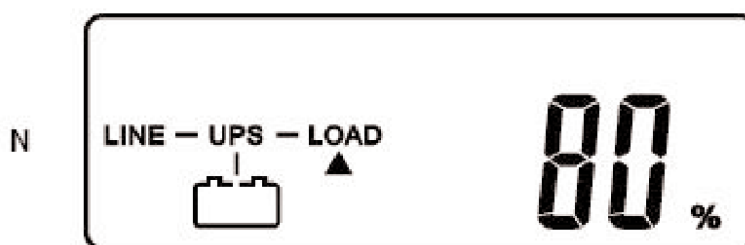

The arrow under the LOAD indicates the reading is for the UPS output and indicates the percentage of output load connected to the UPS.

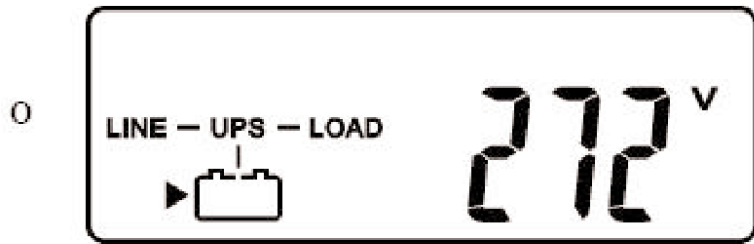

Depress the "Next Page" button.

The arrow next to the battery icon indicates the reading is for the battery voltage.

Depress the "Next Page" button.

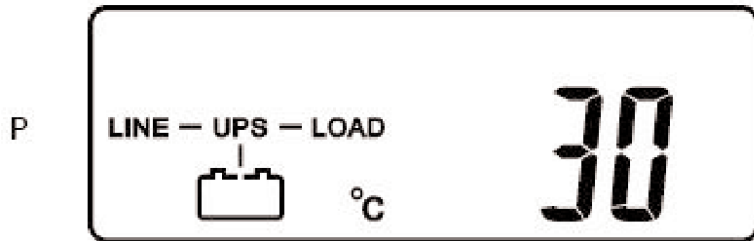

The degree C symbol indicates the reading is for the internal UPS temperature.

Depressing the "Next Page" button again will return the display to reading I1.

## 6.6 How to Display Programmed Settings

1. The UPS must be turned on and operating in on-line inverter mode prior to attempting to read the “programmed settings”.
2. Depress the “Function” button and the following first function parameter will be displayed:

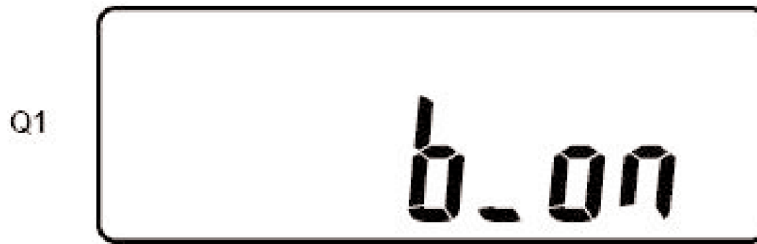

The first function status displayed will be the audible alarm buzzer status. It is shown here to be turned on.



If the “Previous Page/Change Setting” button is pressed, the audible alarm will be turned off. Depressing the button again will turn the alarm back on. Depress the “Next Page” button.



Next, the self-test status is displayed. Here the self-test is shown to be in the “Test Not On” state.



If the “Previous Page/Change Setting” button is pressed, a UPS self-test will be initiated and the following displays will be shown.

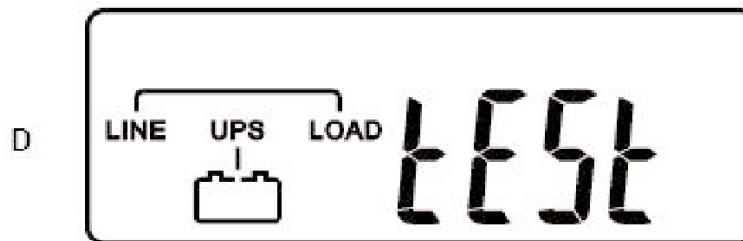





Depress the “Next Page” button.

Go to the next page.

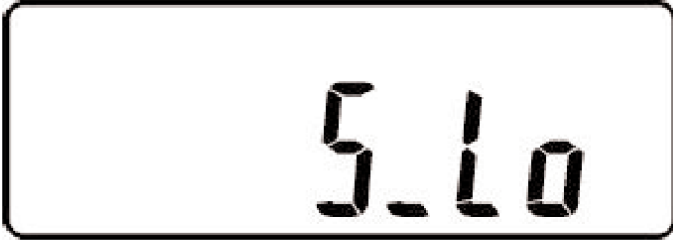
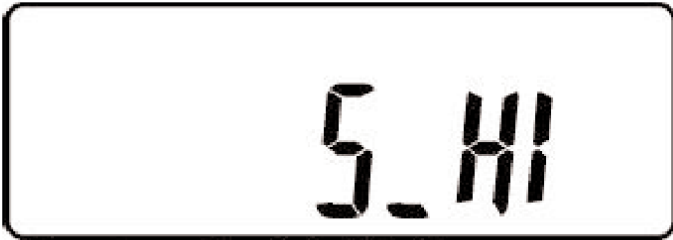

Note: The following functions are a continuation from the previous page. These functions can only be displayed and must have their settings changed using another programming method referenced later in the manual. As the other programming method requires turning the UPS off to perform, they are accessible here as a convenient reference while the UPS is in normal online operation.

S1		The next parameter displayed shows the “bypass input voltage acceptable window” setting. The voltage window can be set to “Lo” (184-260Vac) or “Hi” (195-260Vac), which is shown below.
S2		<u>Depress the “Next Page” button.</u> The next parameter displayed shows acceptable input frequency window. The window can be set to +/-3Hz (shown), or +/-1Hz (not shown).
T		<u>Depress the “Next Page” button.</u> The next parameter display is the inverter output voltage setting. The inverter output voltage can be set to 200Vac (not shown), 220Vac (shown), 230Vac (not shown) or 240Vac (not shown).
U		<u>Depress the “Next Page” button.</u> The following V1, V2, V3 and V4 show the operational status setting of the UPS. This function may be set to one of four modes. “Normal” indicates none of the other modes are set.
V1		
V2		Economy/Green Mode: Indicates the UPS will automatically transfer to bypass mode to save energy, one minute after the output load drops below 10% of the UPS output rating.

V3 

Fixed or constant frequency output mode: In normal mode the UPS output frequency will automatically be set to the utility frequency and is synchronized with that frequency. When set to cf50Hz mode, the UPS inverter output frequency will always be 50Hz. When set to cf60Hz mode, the UPS inverter output frequency will always be 60Hz.

V4 

Setting the UPS to a fixed or constant output frequency should be done when the input source is a generator.

W 

Depress the “Next Page” button.

The next parameter displayed shows the inverter output voltage adjustment. The adjustment can be set to 0% (shown), +1%, -1%, +2%, -2%, +3% or -3% (not shown).

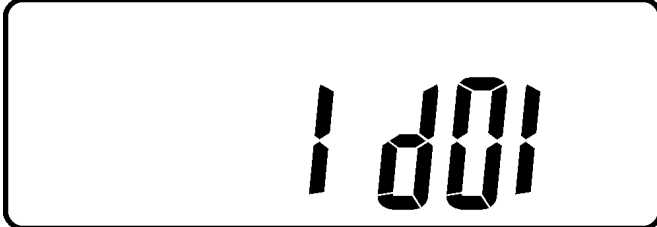
X 

Depress the “Next Page” button.

The next parameter displayed shows the UPS unit address. If only one UPS is being used, the address should be set to “d0” as shown.

If multiple parallel UPS units are connected in a parallel configuration of 6, 12, 18 or 24kVA, or 6, 12, 18kVA N+1 operation, the units would be addressed “d0”, “d1”, “d2” and “d3”. See the parallel mode configuration section on page 30 of this manual for more details.

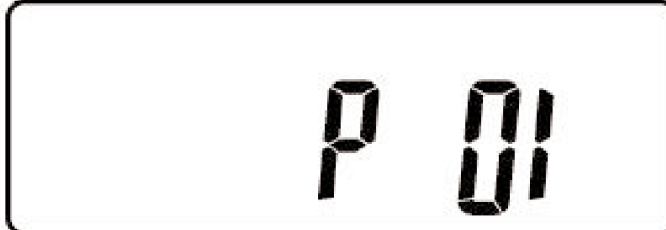
Y 

Depress the “Next Page” button.

The next parameter displayed shows the UPS position when it is used in a parallel configuration. The positions are “01”, “02”, “03”, or “04”.

If only one UPS is being configured, the position should be set to “01” as shown.

## 6.7 How to Change the Programmed Settings

**Note:** The UPS must be placed into Off / Bypass mode prior to attempting to change the following parameter settings.

1. To enter programming mode depress the “On” and “Next Page” buttons at the same time and hold them down until the UPS sounds two beeps. The audible alarm status parameter setting will be displayed.

Q1

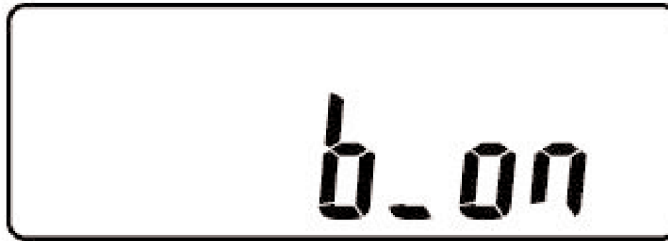

The audible alarm parameter settings cannot be set in this programming mode. Refer to section 6 of this manual for setup instructions.

Q2

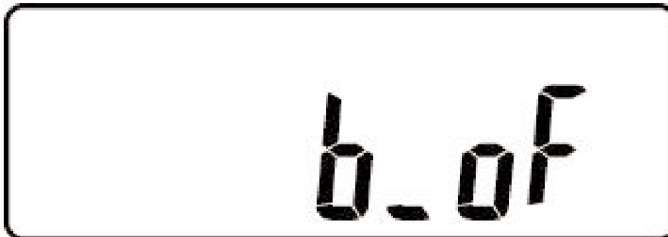

Depress the “Next Page” button.

R1

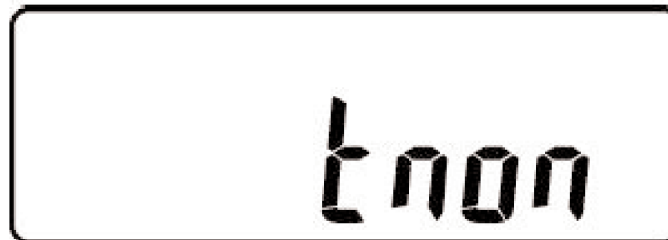

Self-test parameter settings cannot be set in this programming mode. Refer to section 6 of this manual for setup instructions.

R2

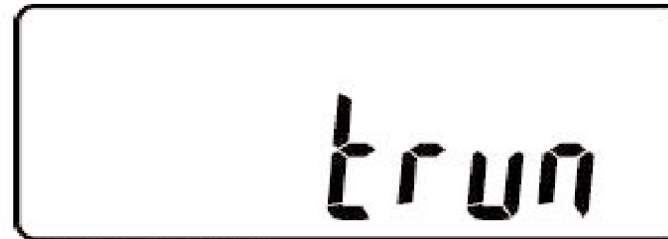

Depress the “Next Page” button and go to the next page.

S1

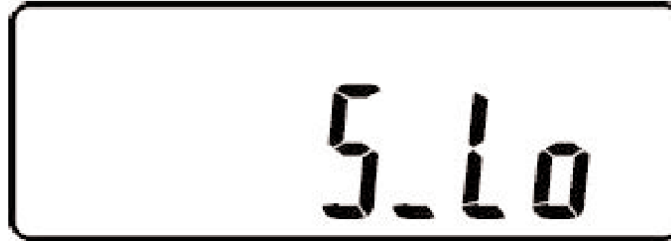

The next parameter displayed shows the “bypass input voltage acceptable window” setting. The voltage window can be set to “Lo” (184-260Vac) or “Hi” (195-260Vac), which is shown below.

S2



To change the settings, depress the “Previous Page/Change Setting” button. To change to the alternate setting, press the button again. All setting changes will be saved when prompted at the end of the parameter sequence.

T

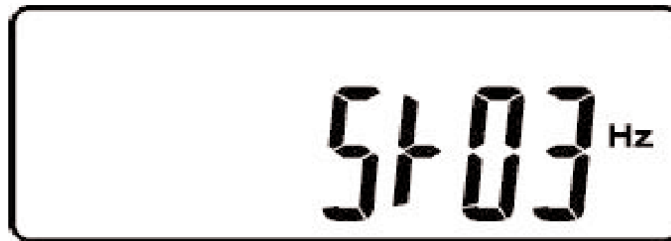

Depress the “Next Page” button.

The next parameter displayed shows the acceptable input frequency window. The window can be set to +/-3Hz (shown), or +/-1Hz (not shown).

To change the settings, depress the “Previous Page/Change Setting” button. To change to the alternate setting, press the button again. All setting changes will be saved when prompted at the end of the parameter sequence.

Depress the “Next Page” button.

U



The next parameter display is the inverter output voltage setting. The inverter output voltage can be set to 200Vac (not shown), 220Vac (shown), 230Vac (not shown) or 240Vac (not shown).

To change the settings, depress the “Previous Page/Change Setting” button. To change to another voltage setting, repeat pressing the button until the desired voltage is displayed. All setting changes will be saved when prompted at the end of the parameter sequence.

Depress the “Next Page” button and go to the next page.



The following V1, V2, V3 and V4 show the operational status setting of the UPS. This function may be set to one of four modes. "Normal": which indicates none of the other modes are set.

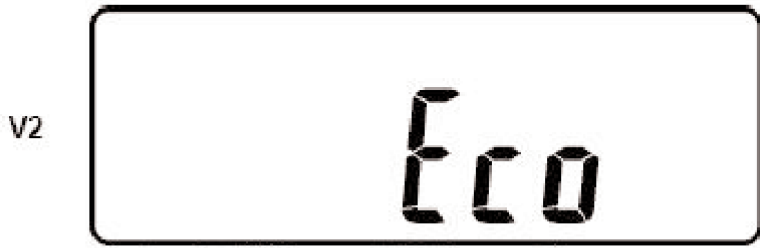

The Economy/Green Mode: indicates the UPS will automatically transfer to bypass mode to save energy, should the output load drop below 10% of the UPS output rating.



Fixed or constant frequency output mode: In normal mode the UPS output frequency will automatically be set to the utility frequency and is synchronized with that frequency. When set to cf50Hz mode, the UPS inverter output frequency will always be 50Hz. When set to cf60Hz mode, the UPS inverter output frequency will always be 60Hz.



Setting the UPS to a fixed or constant output frequency should be done when the input source is a generator.

To change between these settings, depress the "Previous Page/Change Setting" button. Repeat pressing the button until the desired mode setting is displayed. All setting changes will be saved when prompted at the end of the parameter sequence.

Depress the "Next Page" button.

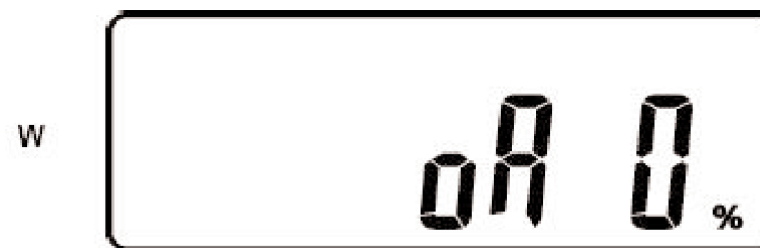

The next parameter displayed shows the inverter output voltage adjustment. The adjustment can be set to 0% (shown), +1%, -1%, +2%, -2%, +3% or -3% (not shown).

To change between these settings, depress the "Previous Page/Change Setting" button. Repeat pressing the button until the desired mode setting is displayed. All setting changes will be saved when prompted at the end of the parameter sequence.

X



The next parameter displayed shows the UPS unit address. If only one UPS is being used, the address should be set to “d0” as shown.

If multiple parallel UPS units are connected on a parallel configuration of 6, 12, 18 or 24kVA, or 6, 12, 18kVA N+1 operation, the units would be addressed “d0”, “d1”, “d2” and “d3”. See the parallel mode configuration section of this manual for more details.

To change between these settings, depress the “Previous Page/Change Setting” button. Repeat pressing the button until the desired address setting is displayed. All setting changes will be saved when prompted at the end of the parameter setup.

Depress the “Next Page” button.

Y

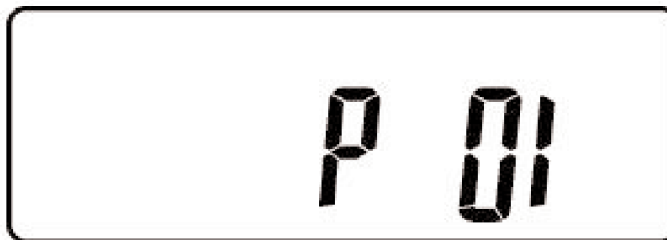

The next parameter displayed shows the UPS position when used in a parallel configuration. The positions are “01”, “02”, “03”, or “04”.

If only one UPS is being configured, the position should be set to “01” as shown.

To change between these settings, depress the “Previous Page/Change Setting” button. Repeat pressing the button until the desired UPS position setting is displayed. All setting changes will be saved when prompted at the end of the parameter setup.

Depress the “Next Page” button.

Z



At the end of the parameter setup mode, you will be prompted to save the settings.

To save the settings press the “Confirm” button. If you do not wish to save the settings, press the Off / Bypass button for five seconds. The LCD will display OFF to indicate the settings are not saved.

**IMPORTANT:**

The UPS must be switched to maintenance bypass mode, shut down and restarted after entering

## **6.8 How to Use the Maintenance Bypass Switch Located on the Rear Panel**

***IMPORTANT: Improper use of the internal Maintenance Bypass Switch will void the equipment warranty. The following instructions must be followed whenever this switch is used.***

1. Press the "Off/Bypass" button for 5 seconds to place the UPS into bypass mode.
2. On the rear of the transformer module, remove the two phillips screws securing the upper and lower sides of the maintenance bypass security cover plate.
3. On the rear of the transformer module, turn the Maintenance Bypass Switch to "Bypass". The maintenance bypass icon will be displayed on the LCD display.
4. The output transformer is now in maintenance bypass mode.
5. To return to normal UPS mode operation, switch the Maintenance Bypass Switch to INV. Replace the switch cover plate and secure it with the screws previously removed.
6. Press the "On" button on the UPS module to return the UPS to normal inverter operation.

## **7.0 COMMUNICATIONS**

All FN models are provided with the following communication ports:  
RS-232 port with standard DB-9F serial port connector located on the UPS module rear panel.  
Two advanced communications option slots are provided on the rear panel of the UPS module.  
Unless an advanced communications option board has been previously purchased and installed, the port will be covered with a small cover plate. This plate will be secured with (2) screws.

**CAUTION:** NEVER INSTALL OPTION CARDS THAT HAVE NOT BEEN SUPPLIED BY FALCON ELECTRIC, OR ARE FOR ANOTHER FALCON MODEL, WITHOUT CONSULTING WITH FALCON SERVICE.

**MOST SG SERIES COMMUNICATIONS BOARDS WILL NOT WORK IN FN SERIES MODELS.**

**ONLY USE OPTION BOARDS THAT ARE SPECIFIED FOR FN 3, 5 & 6kVA MODELS.**

### **7.1 Advanced Communications Option Cards Available:**

- a. USHA TYPE SNMP/HTTP Agent Board
- b. Dry Contact with EPO Interface Board (P/N UA88383)
- c. USB & EPO Interface Board (P/N UA88382)
- d. RS485 & EPO Interface Board (P/N UA88381)
- e. Second RS-232 Interface Card (P/N UA88380)

**CAUTION:** The internal USHA SNMP/HTTP AGENT device must be installed into the Advanced Communications Option Slot specified in this manual. Do not attempt to install it in the contact closure option card slot. The RS-232 port and UPSilon software may not be used when the USHA card is installed.

### **7.2 RS-232 Port**

The UPS is equipped with (1) RS-232 port located on the UPS module rear panel. A standard RS-232C interface cable is provided to allow for the connection of the UPS to another RS-232 port found on most computers. When an RS-232 cable has been connected, and the supplied UPSilon computer shutdown and management software has been properly installed on the connected computer, a high level of UPS management and protection against lost or corrupted files is in effect. **Please follow the installation and setup instructions supplied on the UPSilon software CD.**

The UPSilon users manual is also located on the UPSilon CD supplied with this unit. UPSilon supports most popular operating systems. Should you have special UNIX requirements, please contact Falcon Sales for information and pricing of UPSilon for UNIX.

**The UPS & PC Computer DB-9 pin designations are as follows:**

<b><i>PIN #</i></b>	<b><i>PIN Definition (UPS)</i></b>	<b><i>PIN Definition (PC)</i></b>
<b><i>2</i></b>	<b><i>Transmitted data</i></b>	<b><i>Received data</i></b>
<b><i>3</i></b>	<b><i>Received data</i></b>	<b><i>Transmitted data</i></b>
<b><i>5</i></b>	<b><i>Signal ground</i></b>	<b><i>Signal ground</i></b>



The supplied Falcon RS-232 interface cable pin designations are as follows:

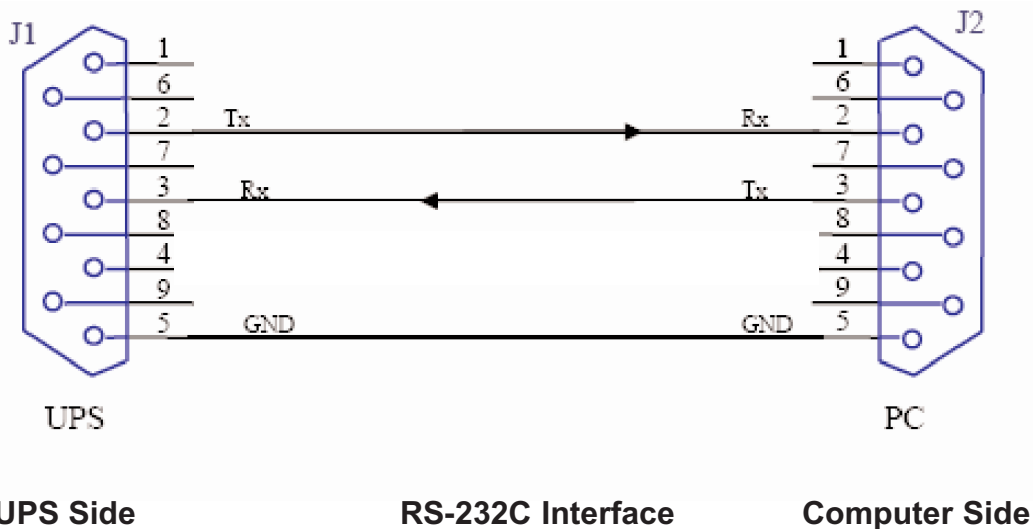

The computer RS-232 Port settings should be set to the following:

<b>Baud Rate</b>	<b>2400 bps</b>
<b>Data Length</b>	<b>8 bits</b>
<b>Stop Bit</b>	<b>1 bit</b>
<b>Parity</b>	<b>None</b>

### 7.3 Optional Remote Emergency Power Off (REPO)

A two-pin REPO connector (green connector) is located on the UPS module rear panel. The connector is shipped with no jumper wire installed, and is a normally open interface requiring a CLOSED EPO connection to initiate EPO UPS shutdown.

Upon receiving the remote EPO switch contact closure, the UPS will immediately turn off its inverter and bypass outputs, in addition to placing the UPS into an "OFF" state and sounding an audible alarm. "OFF" and "EPO" will be alternately displayed on the LCD panel.

After removal of the EPO contact closure, the UPS must be completely shut down and restarted to clear the EPO condition.

### 7.4 Optional Communications Interface Board Details

#### **UA88380 Second RS-232 Interface Option Board**

This communications board supports the connection of a second RS-232 DB-9 connection to the UPS, in addition to providing (1) two-pin EPO interface connector. The DB-9 pinout is identical to the standard DB-9 RS-232 interface found on the UPS rear panel.

#### **UA88381 RS-485 Interface Option Board**

This communications board has (1) RS485 standard interface (CN2), in addition to providing (1) two-pin EPO interface connector (CN1), and (1) two-pin remote power connector (CN3).

Pin 1 - Ground	CN2			Pin 1 - REPO 1	CN1
Pin 2 - A/Data+	1	2	3	Pin 2 - REPO 2	1
Pin 3 - B.Data-					2
	CN3				
Pin 1 - AC+	1	2			
Pin 2 - AC-					

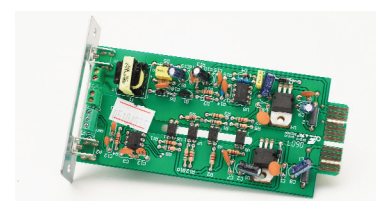

## UA88382 USB Interface Option Card

This option card supports the connection of (1) USB interface cable for use with UPSilon remote monitoring, management and unattended O/S shutdown software.

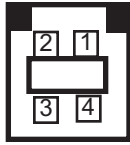

Pin 1 - VCC (+5V)	Pin 1 - REPO 1	CN1
Pin 2 - D-	Pin 2 - REPO2	1 2
Pin 3 - D+		
Pin 4 - Ground		

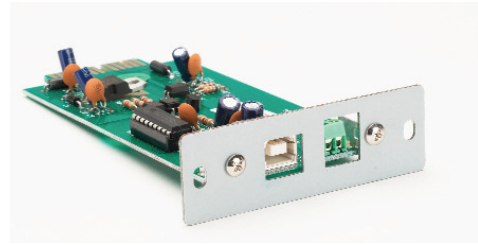

## UA88383 Dry Contact Interface Option Card

This card provides dry contact closure signals for UPS on bypass, utility normal, inverter on, low battery, abnormal battery, UPS summary alarm. It also provides EPO and remote UPS shutdown capability.

1 2 3 4 5 6 7 8 9 10

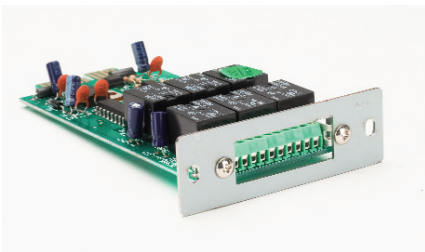

- Pin 1 - UPS on Bypass
- Pin 2 - Utility Abnormal
- Pin 3 - Utility Normal
- Pin 4 - Inverter On
- Pin 5 - Low Battery
- Pin 6 - Abnormal Battery
- Pin 7 - UPS Summary Alarm
- Pin 8 - Common
- Pin 9 - Shutdown UPS (+) signal
- Pin 10 - Shutdown UPS (-) signal

Pins 9 & 10 apply 6-25Vdc for 5 seconds to activate shutdown.

## USHA SNMP/HTTP Agent Option Card

Now you can monitor and manage your Falcon Electric FN Series UPS across an Ethernet LAN, WAN, Enterprise Network or via the World Wide Web. With our Universal SNMP/HTTP Agent board (USHA), remote management is easy using a standard web browser or Network Management Software (NMS).

Remote SNMP/HTTP UPS management is a simple matter of inserting our USHA board into the designated option port provided on the rear panel of every FN Series UPS.

The USHA board is supplied with a SNMP UPS MIB II compliant "snap-in" Management Information Base (MIB). The MIB is compatible with HP OpenView and other Network Management Software (NMS).

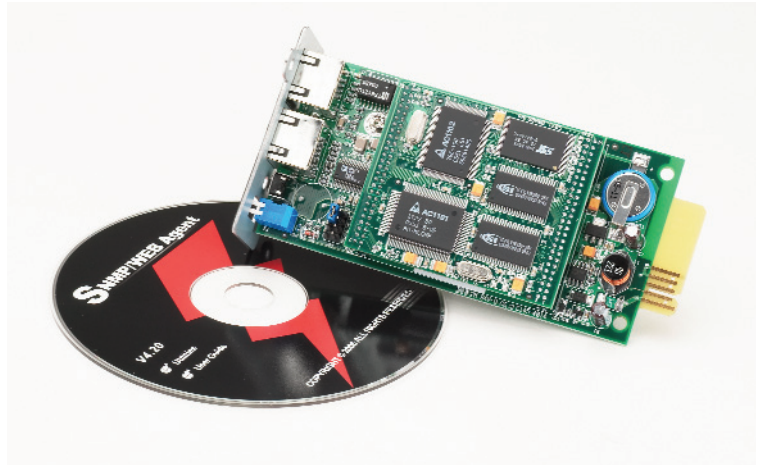

Remote server and computer shutdown client software is also provided on the CD that is shipped with this option. The software supports the shutdown of multiple servers or computers "in-band" across any Ethernet LAN. The client software may be installed on as many systems as required and supports most MS Windows and server platforms, in addition to LINUX.

## **8.0 MAINTENANCE**

The FN Series UPS requires very little maintenance. The batteries are located inside the battery module and consist of (20) Yuasa 12V, 7AH or equivalent, sealed, VRLA, maintenance-free, lead-acid batteries.

Batteries must be kept recharged to prevent excessive self-discharging, which may result in their premature failure. **When connected to the battery module, the UPS will continuously recharge the batteries when plugged in and turned on. When not in use, batteries must be recharged every 6 months to keep your warranty valid.**

### **1. The UPS and Battery Care**

Keep the area around the UPS clean and dust free. If the area around the UPS becomes very dusty, clean it with a vacuum cleaner. To assure the full 3-5 year battery life, keep the UPS battery module at an ambient temperature of 77°F (25°C). Other than replacement at three to five years of service, no other battery maintenance is required.

### **2. Storing the UPS and Batteries**

When storing the UPS for any amount of time, it is recommended to connect the battery module and turn on the UPS for at least 24 hours, every four to six months to ensure full recharging of the batteries. This will prevent excessive battery self-discharge.

### **3. When to Replace Batteries**

We suggest the battery pack(s) be replaced every 3-5 years for FN units that are operated and maintained in a 77°F (25°C) environment. Higher temperature operating environments will decrease the battery life. Typically, if the UPS is installed in a 104°F (40°C) or above operating environment, the batteries will need to be replaced once a year.

In order to assure the performance of the FN Series UPS, check the battery every two to three months by performing a UPS self-test. If at any time the UPS LCD panel displays the weak or defective battery icon or error code, the batteries need replacing. Contact the Falcon Electric Service Department to order replacement batteries.

### **4. Battery Replacement**

Battery replacement inside the battery module must be performed by a qualified service technician. Contact Falcon service when battery replacement is required.



#### ***NOTE!***

**NEVER ATTEMPT TO REPLACE THE BATTERY PACKS WHILE THE UPS IS IN BATTERY MODE.**

## **9.0 PARALLEL MODE OPERATION**

### **9.1 How to configure FN rackmount models for transformer module, parallel or N+1 mode operation.**

Up to (4) like kVA FN model UPS units may be connected to their respective transformer modules and/or in parallel, in single UPS increments, to provide a single 3-24kVA UPS output a true N+1 redundant output. This is accomplished by connecting each UPS to be paralleled, wired to a single utility source rated for the combined UPS load. The UPS outputs should be connected together. A licensed electrician can provide the hard-wire output connections and circuit. Each individual UPS output must have a branch rated circuit breaker as specified prior, installed between the UPS output and load.

FN models have two special bus connectors located on the UPS rear panel that supports interconnection of the transformer module and/or paralleled UPS units. (1) parallel UPS interface kit must be purchased from Falcon for each UPS to be paralleled. The cable kit is shipped with each transformer module inside the shipping container. The interface kit contains (1) daisy chain bus cable (3076), (1) wrap around bus cable (3077), detailed installation instructions and assorted hardware. The Falcon part number for the kit is UA88385.

### **9.2 How to connect the Battery Module to the UPS module.**

1. Open the battery connector cover plate from the UPS module rear panel and connect the supplied red, black and green battery cable connectors to the respectively colored mating connectors on the UPS module.
2. On the battery module rear panel verify the battery circuit breaker is in the off position. Next, open the top battery connector cover plate. Connect the red, black and green connectors on the opposite side of the battery cable to the respectively colored mating connectors on the battery module. Turn on the battery module circuit breaker. The UPS may now be powered up.
3. To add a more battery modules, remove the lower cover plate on the first module and connect a the supplied battery cables to this connector on the previous battery module.

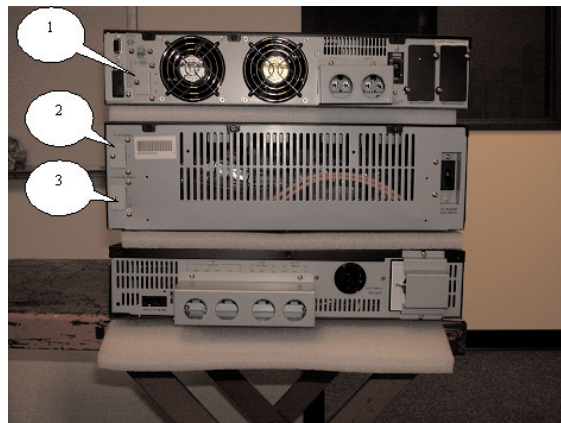

**For more details, contact Falcon Sales or Support Engineering.**

## **10.0 ENVIRONMENTAL**

### **10.1 Recycling the Used Battery Packs**

**NEVER** discard the UPS module, the UPS battery module, the transformer module or batteries in the trash. Contact your local recycling or hazardous waste center for information on proper disposal of the used battery pack and batteries. The entire spent battery packs may be returned to the Falcon Service Center at the end user's expense for recycling. Prior to returning the spent battery pack(s), please call the Falcon Service Center and obtain a Return Materials Authorization (RMA) number.

**NEVER** dispose of batteries in a fire, as batteries will explode.

**NEVER** dispose of used batteries or the UPS in the trash or a landfill as it is a violation of federal and state laws. The UPS and batteries must be recycled. For UPS and battery recycling information, please contact Falcon Service for the name and address of the nearest battery recycling facility.

**NEVER** open or mutilate the battery or batteries. Released electrolyte is harmful to the skin and eyes. It may be toxic. A battery can present a risk of electrical shock and burns due to their high short circuit current capability.

#### **WARNING**

**Observe all warnings, cautions, and notes before replacing batteries. Batteries can present a risk of electrical shock and burns due to high short circuit current. The following precautions should be observed when working on batteries:**

- \* **Remove watches, rings, and other metal objects.**
- \* **Use tools with insulated handles.**
- \* **Do not lay tools or metal parts on top of batteries.**
- \* **Do not attempt to alter any battery wiring or connectors. Attempting to alter wiring can cause injury.**
- \* **Do not dispose of batteries in a fire. The batteries may explode. Refer to your local codes for disposal requirements.**
- \* **Do not open or mutilate the battery packs or batteries. Released electrolyte is harmful to the skin and eyes. It may be toxic.**

### **10.2 FCC Considerations**

**Note:** This equipment has been tested and found to comply with the limits for a Class A digital device, pursuant to part 15 of the FCC Rules. These limits are designed to provide reasonable protection against harmful interference in an industrial installation. This equipment generates, uses and can radiate radio frequency energy and, if not installed and used in accordance with the instructions, may cause harmful interference to radio communications. However, there is no guarantee that interference will not occur in a particular installation. If this equipment does cause harmful interference to radio or television reception, which can be determined by turning the equipment off and on, the user is encouraged to try to correct the interference by one or more of the following measures:

- \* Reorient or relocate the receiving antenna.
- \* Increase the separation between the equipment and receiver.
- \* Connect the equipment into an outlet on a circuit different from that to which the receiver is connected.
- \* Consult the dealer or an experienced radio/TV technician for help.

## **11.0 TECHNICAL SUPPORT**

In the event your FN Series UPS requires service or should any other technical support be required, write, call, fax or email Falcon Service.

Falcon Electric, Inc.  
5106 Azusa Canyon Road  
Irwindale, CA. 91706  
Service 800.842.6940  
Voice 626.962.7770  
Fax 626.962.7720  
Email: [service@falconups.com](mailto:service@falconups.com)  
[WWW.FALCONUPS.COM](http://WWW.FALCONUPS.COM)

Please have your UPS model, serial number and date of purchase on hand prior to your call. This information is located on the identification label on the rear panel of the UPS. This information is essential in retrieving your unit's historical records. Should our service department determine service is required, you will be given a Return Material Authorization number (RMA) along with return shipping instructions.

The RMA number issued must appear on the outside of the shipping carton. The original shipping container must be used when returning any FN Series product. **Failure to use the original shipping container and packing materials will likely result in the unit being received by Falcon with shipping damage.**

**Falcon Electric will not assume any responsibility for shipping damage.** In the event shipping damage is found, you will be notified of the damage and be instructed to file a claim with the freight carrier. You will be billed for all required repairs due to the shipping damage. You must submit a copy of our repair invoice to the carrier for reimbursement.

All units must be returned prepaid. The address and shipping instructions will be given to you at the time the RMA is issued.

### **Requesting Technical Information or Support**

You may request technical information or support by email or telephone.

Please send your technical or support questions by email to:  
**[SUPPORT@FALCONUPS.COM](mailto:SUPPORT@FALCONUPS.COM)**

You may contact a FALCON support engineer directly by calling the FALCON support line between 9:00 am and 4:00 pm PST.  
**800.842.6940**

### **FALCON Web Support**

Product data sheets, specifications and owner's manuals are available in Adobe® Acrobat .PDF format on our corporate website at:

**[WWW.FALCONUPS.COM](http://WWW.FALCONUPS.COM)**

# FALCON ELECTRIC, INC.

## NEW PRODUCT LIMITED WARRANTY

**Limited Warranty:** Falcon warrants that this product will be free from defects in materials and workmanship for a period of two years from the date of shipment by Falcon.

**Procedures:** Any defective product must be returned to Falcon. No product can be returned without first obtaining a Return Material Authorization (RMA) number from Falcon. Falcon will repair, replace or refund the purchaser price, at Falcon's sole discretion, for any defective product that is returned to Falcon with an RMA number. For defective product returned within 30 days of shipment, Falcon will pay for shipping costs to and from its service center. For defective product returned after 30 days but within 90 days of shipment, Falcon will only pay for shipping costs in sending the new or repaired product back to the end-user. For defective product returned more than 90 days after shipment, all shipping costs will be borne by the end-user.

**Exclusions:** This limited warranty does not cover damage caused by: (i) improper installation, misuse or neglect; (ii) unauthorized repairs or modifications or use of unauthorized parts; (iii) acts or events outside of Falcon's control, such as fire, accidents, impacts; (iv) normal wear and tear, such as cleaning and replacement of batteries. The warranty is null and void if: (i) the product is used in conjunction with life support equipment; (ii) the factory seal is broken or shows signs of tampering; or (iii) the battery is allowed to discharge below the minimum battery cutoff point. To prevent this discharge, remove the battery fuse, or switch the battery disconnect to the "off" position when the unit is to be stored without the AC power being supplied to the UPS for more than two days. The battery must be recharged every four to six months when not in use. This limited warranty is not transferable.

**Limitations:** IN NO EVENT IS FALCON RESPONSIBLE FOR ANY SPECIAL, INDIRECT, SECONDARY OR CONSEQUENTIAL DAMAGES, SUCH AS PERSONAL INJURY, DAMAGE TO PROPERTY, LOSS OF DATA, LOST PROFITS, ETC. IN NO EVENT WILL FALCON'S LIABILITY UNDER THIS LIMITED WARRANTY EXCEED THE PURCHASE PRICE PAID FOR THE PRODUCT IN QUESTION.

**Disclaimers:** The limited warranties set forth in this document are the only warranties that apply to Falcon's products. **ALL OTHER WARRANTIES ARE EXPRESSLY DISCLAIMED, INCLUDING ANY IMPLIED WARRANTIES OF MERCHANTABILITY OR FITNESS FOR A PARTICULAR PURPOSE. THIS WARRANTY GIVES YOU SPECIFIC LEGAL RIGHTS, AND YOU MAY HAVE OTHER LEGAL RIGHTS THAT VARY FROM STATE TO STATE.**

2007-04 Rev. C

Model Number (Includes FNITRM-6K-2)	FN3KRM-2TXI	FN3RMK-2TXI	FN3KRM-2TXI	FN3KRM-2TXI
<b>Number of Parallel Units</b>	<b>1</b>	<b>2</b>	<b>3</b>	<b>4</b>
N+1 VA Rating	N/A	3,000	6,000	9,000
Maximum VA Rating (non-N+1)	3,000	6,000	9,000	12,000
<b>Electrical Input</b>				
Nominal AC Voltage	208 or 240Vac (Please specify the input voltage at the time of order)			
Voltage Range	160Vac – 280Vac			
Bypass Voltage Window	184-260Vac or 195-260Vac (Programmable)			
Current-Amps (system)	N/A	14.5A	29A	N/A
(non-N+1)	14.5A	29A	44A	58A
Frequency	50/60 Hz (Synchronized Auto – Tracking) or 47-63 Hz (Programmable Unsynchronized)			
Power Factor Correction	> 0.95			
Efficiency (AC-AC)	Up to 90%			
(Battery Mode)	85%			
<b>Electrical Output</b>				
Watts	2,100	4,200	6,300	8,400
N+1 Redundant Mode	N/A	2,100	4,200	6,300
Voltage (Non-isolated) <b>(UPS OUTPUT ONLY)</b>	208, 220, 230, 240Vac Programmable (UPS modules may not be connected in parallel without a FNITRM-6K-2 isolation module installed on the output of each UPS module.)			
Voltage (Isolated) <b>(FNITRM-6K-2 OUTPUT)</b>	Note: Two 120Vac outputs may be connected in parallel to provide a single 120Vac output. 240/120Vac Split-Phase (3 wire plus ground) or			
Overload Capability	<105% of 2100 Watts continuous output (each UPS) 115% of 2100 Watts for 83 Seconds (each UPS) 125% of 2100 Watts for 25 seconds (each UPS) 150% of 2100 Watts for 320 milliseconds (each UPS)			
Voltage Regulation	-2 Model UPS Module ±2% -2TXI Model With Output Transformer Module ±3%			
Voltage Adjustment	±0%, ±1%, ±2% or ±3% (Programmable)			
Frequency	50/60 Hz ±5Hz (Synchronized Auto-Tracking) or 50 Hz and 60 Hz (Programmable Fixed Output)			
Frequency Stability	±0.2% (Fixed frequency operation) Fixed frequency output available in non-parallel configurations only.			
Frequency Window	±1 Hz or ±3 Hz (Programmable, Auto-Tracking mode)			
Harmonic Distortion	5% Typical			
Crest Ratio	3:1			
<b>Battery</b>				
DC Voltage	240Vdc			
Type	12V, 9AH Sealed Lead Acid Maintenance-Free (20 pieces)			
Charger Current	1.5A			
Back Up Time @ Full Load	31 Minutes			
@ 1/2 Load	78 Minutes			
Recharge Time	4 Hours to 90%			
Replacement	Hot-Swappable & User-Replaceable Through Removable Front Panel			
<small>Battery times are approximate.</small>				
<b>Transfer Time</b>				
Line Falls/Recovers	0 ms			
UPS to Bypass or Reverse	0-1 ms			
After Overload	Auto Transfer to UPS			
<b>Electrical Connections</b>				
Input	Hardwire Terminal Block			
Output	Hardwire Terminal Block			
REPO	Hardwire Connector Supplied			
<b>Environmental</b>				
Operating Temperature	0° C - 40° C (32° F to 104° F)			
Humidity	10% to 95% Non – Condensing			
Altitude	10,000 Feet			
Cooling	Low Velocity Forced Air Fans			
Audible Noise @ 1 Meter	50 dbA			
<b>Controls and Indicators</b>				
Status on LCD & LED	Line mode, Backup mode, ECO (green) mode, Bypass, Low Battery, Defective Battery, Overload, UPS Alarm, Transferring with interruption			
LCD Displayed Readings	Input Voltage, Input Frequency, Output Voltage, Output Frequency, Load Percentage, Battery Voltage, Internal Temperature			
Self-Diagnostics	At power up, Manual front panel button & Software control with programmable 24-hour automatic self-test			
Audible Alarms	Utility Loss, Low Battery, Transfer to Bypass and UPS Failure			
Communications	RS-232 Serial Port (Bundled UPSilon 2000 Software) & REPO Connector			
<b>Mechanical</b>				
UPS Dimensions H x W x D	2U	2U	2U	2U
inches	3.47 x 17.4 x 26.3	3.47 x 17.4 x 26.3	3.47 x 17.4 x 26.3	3.47 x 17.4 x 26.3
(mm)	88 x 440 x 667	88 x 440 x 667	88 x 440 x 667	88 x 440 x 667
Number of cabinets	1	2	3	4
Battery Bank Dimensions H x W x D	3U	3U	3U	3U
Model FNBRM-1S9 inches	6.93 x 17.4 x 26.3	6.93 x 17.4 x 26.3	6.92 x 17.4 x 26.3	6.93 x 17.4 x 26.3
(included with all models) (mm)	176 x 440 x 667	176 x 440 x 667	176 x 440 x 667	176 x 440 x 667
Number of cabinets	1	2	3	4
Transformer Module H x W x D	2U	2U	2U	2U
Model FNITRM-6K-2 inches	3.47 x 17.4 x 26.3	3.47 x 17.4 x 26.3	3.47 x 17.4 x 26.3	3.47 x 17.4 x 26.3
(included with -2TXI models) (mm)	88 x 440 x 667	88 x 440 x 667	88 x 440 x 667	88 x 440 x 667
Number of cabinets	1	2	3	4
UPS Weight lb. (kg)	53 (24)	106 (48)	159 (72)	212 (96)
Battery Bank Weight lb. (kg)	150 (68)	300 (136)	450 (204)	600 (272)
Transformer Module lb. (kg)	91 (41)	181 (82)	272 (123)	362 (164)
Agency Listing	UL 1778 & cUL Listed, CE and FCC Class A			



Model Number (Includes FNITRM-6K-2)	FN4KRM-2TXI	FN4KRM-2TXI	FN4KRM-2TXI	FN4KRM-2TXI
<b>Number of Parallel Units</b>	<b>1</b>	<b>2</b>	<b>3</b>	<b>4</b>
N+1 VA Rating	N/A	4,000	8,000	12,000
Maximum VA Rating (non-N+1)	4,000	8,000	12,000	18,000
<b>Electrical Input</b>				
Nominal AC Voltage	208 or 240Vac			
Voltage Range	160Vac – 280Vac			
Bypass Voltage Window	184-260Vac or 195-260Vac (Programmable)			
Current-Amps (system) N+1 (non-N+1)	N/A 19.3A	19.3A 38.5A	38.5A 58A	N/A 77A
Frequency	50/60 Hz (Synchronized Auto – Tracking) or 47-63 Hz (Programmable Unsynchronized)			
Power Factor Correction	> 0.95			
Efficiency (AC-AC) (Battery Mode)	Up to 90% 85%			
<b>Electrical Output</b>				
Watts	2,800	5,200	8,400	11,200
N+1 Redundant Mode	N/A	2,800	5,200	8,400
Voltage (Non-isolated) <b>(UPS OUTPUT ONLY)</b>	208, 220, 230, 240Vac Programmable (UPS modules may not be connected in parallel without a FNITRM-6K-2 isolation module installed on the output of each UPS module.)			
Voltage (Isolated) <b>(FNITRM-6K-2 OUTPUT)</b>	Please specify the output voltage configurations desired at the time of order. Note: Two 120Vac outputs may be connected in parallel to provide a single 120Vac output. 240/120Vac Split-Phase (3 wire plus ground) or			
Overload Capability	<105% of 3500 Watts continuous output (each UPS) 115% of 3500 Watts for 83 Seconds (each UPS) 125% of 3500 Watts for 25 seconds (each UPS) 150% of 3500 Watts for 320 milliseconds (each UPS)			
Voltage Regulation	-2 Model UPS Module ±2% -2TXI Model Output Transformer Module ±3%			
Voltage Adjustment	±0%, ±1%, ±2% or ±3% (Programmable)			
Frequency	50/60 Hz ± 5Hz (Synchronized Auto-Tracking) or 50 Hz and 60 Hz (Programmable Fixed Output)			
Frequency Stability	±0.2% (Fixed frequency operation) Fixed frequency output available in non-parallel configurations only.			
Frequency Window	±1 Hz or ±3 Hz (Programmable, Auto-Tracking mode)			
Harmonic Distortion	5% Typical			
Crest Ratio	3:1			
<b>Battery</b>				
DC Voltage	240Vdc			
Type	12V, 9AH Sealed Lead Acid Maintenance-Free (20 pieces)			
Charger Current	1.5A			
Back Up Time @ Full Load @ 1/2 Load	21 Minutes 54 Minutes			
Recharge Time	4 Hours to 90%			
Replacement	Hot-Swappable & User-Replaceable Through Removable Front Panel			
<b>Battery times are approximate.</b>				
<b>Transfer Time</b>				
Line Fails/Recovers	0 ms			
UPS to Bypass or Reverse	0-1 ms			
After Overload	Auto Transfer to UPS			
<b>Electrical Connections</b>				
Input	Hardwire Terminal Block			
Output	Hardwire Terminal Block			
REPO	Hardwire Connector Supplied			
<b>Environmental</b>				
Operating Temperature	0° C - 40° C (32° F to 104° F)			
Humidity	10% to 95% Non – Condensing			
Altitude	10,000 Feet			
Cooling	Low Velocity Forced Air Fans			
Audible Noise @ 1 Meter	50 dbA			
<b>Controls and Indicators</b>				
Status on LCD & LED	Line mode, Backup mode, ECO (green) mode, Bypass, Low Battery, Defective Battery, Overload, UPS Alarm, Transferring with interruption			
LCD Displayed Readings	Input Voltage, Input Frequency, Output Voltage, Output Frequency, Load Percentage, Battery Voltage, Internal Temperature			
Self-Diagnostics	At power up, Manual front panel button, Software control with programmable 24-hour automatic self-test			
Audible Alarms	Utility Loss, Low Battery, Transfer to Bypass and UPS Failure			
Communications	RS-232 Serial Port (Bundled UPSilon 2000 Software) & REPO Connector			
<b>Mechanical</b>				
UPS Dimensions H x W x D inches (mm)	2U 3.47 x 17.4 x 26.3 88 x 440 x 667	2U 3.47 x 17.4 x 26.3 88 x 440 x 667	2U 3.47 x 17.4 x 26.3 88 x 440 x 667	2U 3.47 x 17.4 x 26.3 88 x 440 x 667
Number of cabinets	1	2	3	4
Battery Bank Dimensions H x W x D inches (included with all models) (mm)	3U 6.93 x 17.4 x 26.3 176 x 440 x 667	3U 6.93 x 17.4 x 26.3 176 x 440 x 667	3U 6.93 x 17.4 x 26.3 176 x 440 x 667	3U 6.93 x 17.4 x 26.3 176 x 440 x 667
Number of cabinets	1	2	3	4
Transformer Module H x W x D inches (included with -2TXI models) (mm)	2U 3.47 x 17.4 x 26.3 88 x 440 x 667	2U 3.47 x 17.4 x 26.3 88 x 440 x 667	2U 3.47 x 17.4 x 26.3 88 x 440 x 667	2U 3.47 x 17.4 x 26.3 88 x 440 x 667
Number of cabinets	1	2	3	4
UPS Weight lb. (kg)	53 (24)	106 (48)	159 (72)	212 (96)
Battery Bank Weight lb. (kg)	150 (68)	300 (136)	450 (204)	600 (272)
Transformer Module (option) lb. (kg)	91 (41)	181 (82)	272 (123)	362 (164)
Agency Listing	UL 1778 & cUL Listed, CE and FCC Class A			

Model Number (without FNITRM-6K-2) (Includes FNITRM-6K-2)	FN5KRM-2				
	FN5KRM-2TXI	FN5KRM-2TXI	FN5KRM-2TXI	FN5KRM-2TXI	
<b>Number of Parallel Units</b>	<b>1</b>	<b>2</b>	<b>3</b>	<b>4</b>	
N+1 VA Rating	N/A	5,000	10,000	15,000	
Maximum VA Rating (non-N+1)	5,000	10,000	15,000	20,000	
<b>Electrical Input</b>					
Nominal AC Voltage	208 or 240Vac				
Voltage Range	160Vac – 280Vac				
Bypass Voltage Window	184-260Vac or 195-260Vac (Programmable)				
Current-Amps (system) N+1 (non-N+1)	N/A 24A	24A 57A	57A 70A	N/A 93A	
Frequency	50/60 Hz (Synchronized Auto – Tracking) or 47-63 Hz (Programmable Unsynchronized)				
Power Factor Correction	> 0.95				
Efficiency (AC-AC) (Battery Mode)	Up to 90% 85%				
<b>Electrical Output</b>					
Watts	3,500	7,000	10,500	14,000	
N+1 Redundant Mode	N/A	3,500	7,000	10,500	
Voltage (Non-Isolated) <b>(-2 UPS MODEL ONLY)</b>	208, 220, 230, 240Vac Programmable (UPS modules may not be connected in parallel without a FNITRM-6K-2 isolation module installed on the output of each UPS module.)				
Voltage (Isolated) <b>(-2TXI UPS MODELS ONLY)</b>	Please specify the output voltage configurations desired at the time of order. Note: Two 120Vac outputs may be connected in parallel to provide a single 120Vac output. 240/120Vac Split-Phase (3 wire plus ground) or				
Overload Capability	<105% of 3500 Watts continuous output (each UPS) 115% of 3500 Watts for 83 Seconds (each UPS) 125% of 3500 Watts for 25 seconds (each UPS) 150% of 3500 Watts for 320 milliseconds (each UPS)				
Voltage Regulation	UPS Module Output ±2% Output Transformer Module Output ±3%				
Voltage Adjustment	±0%, ±1%, ±2% or ±3% (Programmable)				
Frequency	50/60 Hz ± 5Hz (Synchronized Auto-Tracking) or 50 Hz and 60 Hz (Programmable Fixed Output)				
Frequency Stability	±0.2% (Fixed frequency operation) Fixed frequency output available in non-parallel configurations only.				
Frequency Window	±1 Hz or ±3 Hz (Programmable, Auto-Tracking mode)				
Harmonic Distortion	5% Typical				
Crest Ratio	3:1				
<b>Battery</b>					
DC Voltage	240Vdc				
Type	12V, 9AH Sealed Lead Acid Maintenance-Free (20 pieces)				
Charger Current	1.5A				
Back Up Time @ Full Load	15.6 Minutes				
@ 1/2 Load	40 Minutes				
Recharge Time	4 Hours to 90%				
Replacement	Hot-Swappable & User-Replaceable Through Removable Front Panel				
Battery times are approximate.					
<b>Transfer Time</b>					
Line Fails/Recovers	0 ms				
UPS to Bypass or Reverse	0-1 ms				
After Overload	Auto Transfer to UPS				
<b>Electrical Connections</b>					
Input	Hardwire Terminal Block				
Output	Hardwire Terminal Block				
REPO	Hardwire Connector Supplied				
<b>Environmental</b>					
Operating Temperature	0° C - 40° C (32° F to 104° F)				
Humidity	10% to 95% Non – Condensing				
Altitude	10,000 Feet				
Cooling	Low Velocity Forced Air Fans				
Audible Noise @ 1 Meter	50 dbA				
<b>Controls and Indicators</b>					
Status on LCD & LED	Line mode, Backup mode, ECO (green) mode, Bypass, Low Battery, Defective Battery, Overload, UPS Alarm, Transferring with interruption				
LCD Displayed Readings	Input Voltage, Input Frequency, Output Voltage, Output Frequency, Load Percentage, Battery Voltage, Internal Temperature				
Self-Diagnostics	At power up, Manual front panel button, Software control with programmable 24-hour automatic self-test				
Audible Alarms	Utility Loss, Low Battery, Transfer to Bypass and UPS Failure				
Communications	RS-232 Serial Port (Bundled UPSilon 2000 Software) & REPO Connector				
<b>Mechanical</b>					
UPS Dimensions H x W x D	2U	2U	2U	2U	
inches	3.47 x 17.4 x 26.3	3.47 x 17.4 x 26.3	3.47 x 17.4 x 26.3	3.47 x 17.4 x 26.3	
(mm)	88 x 440 x 667	88 x 440 x 667	88 x 440 x 667	88 x 440 x 667	
Number of cabinets	1	2	3	4	
Battery Bank Dimensions H x W x D	3U	3U	3U	3U	
Model FNBR1S9	6.93 x 17.4 x 26.3	6.93 x 17.4 x 26.3	6.92 x 17.4 x 26.3	6.93 x 17.4 x 26.3	
inches	176 x 440 x 667	176 x 440 x 667	176 x 440 x 667	176 x 440 x 667	
(mm)					
Number of cabinets	1	2	3	4	
Transformer Module H x W x D	2U	2U	2U	2U	
Model FNITR-6K-2	3.47 x 17.4 x 26.3	3.47 x 17.4 x 26.3	3.47 x 17.4 x 26.3	3.47 x 17.4 x 26.3	
inches	88 x 440 x 667	88 x 440 x 667	88 x 440 x 667	88 x 440 x 667	
(mm)					
Number of cabinets	1	2	3	4	
UPS Weight	lb. (kg)	53 (24)	106 (48)	159 (72)	212 (96)
Battery Bank Weight	lb. (kg)	150 (68)	300 (136)	450 (204)	600 (272)
Transformer Module (option)	lb. (kg)	91 (41)	181 (82)	272 (123)	362 (164)
Agency Listing	UL 1778 & cUL Listed, CE and FCC Class A				

Model Number (without FNITRM-6K-2) (includes FNITRM-6K-2)	FN6KRM-2			
	FN6KRM-2TXI	FN6KRM-2TXI	FN6KRM-2TXI	FN6KRM-2TXI
<b>Number of Parallel Units</b>	<b>1</b>	<b>2</b>	<b>3</b>	<b>4</b>
N+1 VA Rating	N/A	6,000	12,000	18,000
Maximum VA Rating (non-N+1)	6,000	12,000	18,000	24,000
<b>Electrical Input</b>				
Nominal AC Voltage	208 or 240Vac			
Voltage Range	160Vac – 280Vac			
Bypass Voltage Window	184-260Vac or 195-260Vac (Programmable)			
Current-Amps (system)	N/A	29A	58A	N/A
(non-N+1)	29A	58A	87A	116A
Frequency	50/60 Hz (Synchronized Auto – Tracking) or 47-63 Hz (Programmable Unsynchronized)			
Power Factor Correction	> 0.95			
Efficiency (AC-AC)	Up to 90%			
(Battery Mode)	85%			
<b>Electrical Output</b>				
Watts	4,200	8,400	12,600	16,800
N+1 Redundant Mode	N/A	4,200	8,400	12,600
Voltage (Non-Isolated) <b>(-2 MODEL ONLY)</b>	208, 220, 230, 240Vac Programmable (UPS modules may not be connected in parallel without a FNITRM-6K-2 isolation module installed on the output of each UPS module.)			
Voltage (Isolated) <b>(-2TXI MODELS ONLY)</b>	Please specify the output voltage configurations desired at the time of order. Note: Two 120Vac outputs may be connected in parallel to provide a single 120Vac output. 240/120Vac Split-Phase (3 wire plus ground) or			
Overload Capability	<105% of 4200 Watts continuous output (each UPS) 115% of 4200 Watts for 83 Seconds (each UPS) 125% of 4200 Watts for 25 seconds (each UPS) 150% of 4200 Watts for 320 milliseconds (each UPS)			
Voltage Regulation	UPS Module Output ±2% Output Transformer Module Output ±3%			
Voltage Adjustment	±0%, ±1%, ±2% or ±3% (Programmable)			
Frequency	50/60 Hz ±5Hz (Synchronized Auto-Tracking) or 50 Hz and 60 Hz (Programmable Fixed Output)			
Frequency Stability	±0.2% (Fixed frequency operation) Fixed frequency output available in non-parallel configurations only.			
Frequency Window	±1 Hz or ±3 Hz (Programmable, Auto-Tracking mode)			
Harmonic Distortion	5% Typical			
Crest Ratio	3:1			
<b>Battery</b>				
DC Voltage	240Vdc			
Type	12V, 9AH Sealed Lead Acid Maintenance-Free (20 pieces)			
Charger Current	1.5A			
Back Up Time Full/Half Load	12 Minutes / 31 Minutes			
Recharge Time	4 Hours to 90%			
Replacement	Hot-Swappable & User-Replaceable Through Removable Front Panel			
Battery times are approximate.				
<b>Transfer Time</b>				
Line Falls/Recovers	0 ms			
UPS to Bypass or Reverse	0-1 ms			
After Overload	Auto Transfer to UPS			
<b>Electrical Connections (UPS, Output Isolation Transformer &amp; Battery Bank)</b>				
Input	Hardwire Terminal Block			
Output	Hardwire Terminal Block			
REPO	Hardwire Connector Supplied			
<b>Environmental</b>				
Operating Temperature	0° C - 40° C (32° F to 104° F)			
Humidity	10% to 95% Non – Condensing			
Altitude	10,000 Feet			
Cooling	Low Velocity Forced Air Fans			
Audible Noise @ 1 Meter	50 dbA			
<b>Controls and Indicators</b>				
Status on LCD & LED	Line mode, Backup mode, ECO (green) mode, Bypass, Low Battery, Defective Battery, Overload, UPS Alarm, Transferring with Interruption			
LCD Displayed Readings	Input Voltage, Input Frequency, Output Voltage, Output Frequency, Load Percentage, Battery Voltage, Internal Temperature			
Self-Diagnostics	At power up, Manual front panel button, Software control with programmable 24-hour automatic self-test			
Audible Alarms	Utility Loss, Low Battery, Transfer to Bypass and UPS Failure			
Communications	RS-232 Serial Port (Bundled UPSilon 2000 Software) & REPO Connector			
<b>Mechanical</b>				
UPS Dimensions H x W x D	2U	2U	2U	2U
inches	3.47 x 17.4 x 26.3	3.47 x 17.4 x 26.3	3.47 x 17.4 x 26.3	3.47 x 17.4 x 26.3
(mm)	88 x 440 x 667	88 x 440 x 667	88 x 440 x 667	88 x 440 x 667
Number of cabinets	1	2	3	4
Battery Bank Dimensions H x W x D	3U	3U	3U	3U
Model FNBRM-1S9	6.93 x 17.4 x 26.3	6.93 x 17.4 x 26.3	6.92 x 17.4 x 26.3	6.93 x 17.4 x 26.3
inches	176 x 440 x 667	176 x 440 x 667	176 x 440 x 667	176 x 440 x 667
(mm)				
Number of cabinets	1	2	3	4
Transformer Module H x W x D	2U	2U	2U	2U
Model FNITRM-2	3.47 x 17.4 x 26.3	3.47 x 17.4 x 26.3	3.47 x 17.4 x 26.3	3.47 x 17.4 x 26.3
inches	88 x 440 x 667	88 x 440 x 667	88 x 440 x 667	88 x 440 x 667
(mm)				
Number of cabinets	1	2	3	4
UPS Weight	53 (24)	106 (48)	159 (72)	212 (96)
lb. (kg)				
Battery Bank Weight	150 (68)	300 (136)	450 (204)	600 (272)
lb. (kg)				
Transformer Module (option)	92.5 (41.96)	185 (83.9)	277.5 (125.7)	370 (187.9)
lb. (kg)				
Agency Listing	UL 1778 & cUL Listed, CE and FCC Class A			
<b>Available Options</b>				
<b>OPTION</b>	<b>DESCRIPTION</b>		<b>OPTION</b>	<b>DESCRIPTION</b>
FNBRM-1S9	External Rackmount Battery Bank (1 parallel 9AH battery strings) (2U)		FNITRM-2	3-6kVA Isolation Transformer Module (3U)
Option A	USHA SNMP/HTTP Network Card		Option D	Optional RS485 Interface board
Option B	Contact Closure Interface Card		Option E	Optional USB Interface board
Option C	2 <sup>nd</sup> RS-232 Interface Card		Option F	Parallel cable kit