

BC840/M/E, Compact BLE 5, Thread, Zigbee Modules Ver 0.30 Dec. 2018

BluNor BC840 is a powerful, highly flexible, ultra low power Bluetooth Low Energy (BLE) using Nordic nRF52840 SoC. With an ARM Cortex™ M4F MCU, available 1MB flash, 256KB RAM, embedded 2.4GHz multi-protocol transceiver, and an integrated PCB trace antenna. It allows faster time to market with reduced development cost.

BC840 size is compact(7.0x9.0x1.5mm), short range (10 meters) module. It is ideal for wearable. BC832M is compact in size. Its range is estimated at 1000 meters for 125 Kbps data rate.

Specifications:

- nRF52840 CKA, ARM Cortex M4F, 64 MHz
- ARM® TrustZone® Cryptocell-310 co-processor
- Complete RF solution with integrated antenna
- BLE 5 data rate: 2Mbps, 1Mbps, 500kbps, 125kbps.
- IEEE 802.15.4 Thread and Zigbee data rate: 250 Kbps
- 2.4 GHz proprietary data rate: 2 Mbps, 1 Mbps
- DC-DC converter, inductors on board.
- Direct powered by Lithium batteries or USB supply (up to 5.5V)
- 32 MHz main crystal on board.
- Serial Wire Debug (SWD)
- Nordic SoftDevice Ready
- Over-the-Air (OTA) firmware update
- Flash/RAM: 1MB/256KB.
- 48 General purpose I/O pins
- USB 2.0 full speed (12 Mbps) controller
- QSPI 32 MHz interface
- High speed 32 MHz SPI
- Type 2 NFC-A tag with wake-on field, Touch-to-pair support
- Programmable peripheral interconnect (PPI)
- 12 bit/200 Ksps ADC, 8 configurable channels with programmable gain
- 64 level comparator
- 15 level comparator with wake-up from OFF mode
- Temperature sensor
- 4x4-channel pulse width modulator (PWM)
- Audio peripherals: I2S, digital microphone interface (PDM)
- 5 x 32 bit timers with counter mode
- Up to 4x SPI masters/3x SPI slaves
- Up to 2x I2C compatible 2-wire masters/slaves
- 2x UART (CTS/RTS)
- Quadrature Demodulator (QDEC)
- 3x real time counters (RTC)
- 128-bit AES HW encryption
- SoC Receiver Sensitivity: -96 dBm at 1Mbps
- SoC TX power: programmable +8dBm to -20dBm.
- LGA, 64 pins.
- Integrated PCB trace antenna
- Operation voltage: 1.7V to 5.5V
- Operation temperature: -40°C to +85°C
- QDID: 108621
- FCC ID: Pending
- IC IC Pending
- CE, TELEC, RCM: Pending

Applications

- Wearable
- Secure IoT
- Beacons/Proximity
- Connected appliances



BC840/M/E, Compact BLE 5, Thread, Zigbee Modules Ver 0.30 Dec. 2018

■ Lighting products

■ Home and building automation

■ Sensors

Model Summaries

module	BC840	BC840M	BC840E
SoC	nRF52840-CKAA	nRF52840-CKAA	nRF52840-CKAA
Size, mm	7.0x9.0x1.5	7.0 (10 antenna area)x12.0x1.5	7.0x12.0x1.5
BT Antenna	PCB trace	PCB trace	u.FL
BT range, 1 Mbps, LMPI	10 meters, est.	150 meters.est	
BT range, 1Mbps, 1.52m			
BT range, 125 Kbps, LMPI.		400 meters, est.	
BT range, 125 kbps, 1.52m			
Availability	Sample	Sample	Sample

Table Of Contents

1. Introduction	4
BC840 Block Diagram.....	4
BC840	5
BC840M	5
BC840E	5
2. Codes Development Using Nordic Tools	5
Easy, fast and safe code development	5
Over-The-Air DFU	5
SoftDevices	5
Development Tools	6
3. Product Descriptions.....	7
Block Diagram of nRF52840.....	7
ARM Trustzone CryptoCell 310	9
Mechanical Drawings.....	12
Pin Assignments of BC840, BC840M, and BC840E	14
Pin Function	16
Mounting BC840 and BC840M on the Host PCB.....	17
Host Board Layout	17
4. BC840 Evaluation Board	18
Nordic Development Tools	18
Android OS Apps	19
iOS Apps	19
BC840 EvaluationBoard Schematics.....	20
Suggestion for Battery Power Application	21
5. Production	22
Preloaded Firmware.....	22
AT Command Codes	22
Soldering Temperature-Time Profile for Re-Flow Soldering	23
Cautions, Design Notes, and Installation Notes.....	23
Packaging.....	26
FCC Label	26
Revision History.....	27
6. Contact Us	錯誤! 尚未定義書籤。

1. Introduction

BluNor BC840 Series are powerful, highly flexible, ultra low power wireless modules using Nordic nRF52840 SoCs. With an ARMCortex™ M4F MCU, 1MB flash, 256KB RAM, embedded 2.4GHz multi-protocol transceiver, and an integrated antenna, it allows faster time to market with reduced development cost.

The following is a block diagram of BC840. Antenna circuit and main clock are integrated. All 48 GPIOs of nRF52840 can be accessed from main board. For lower power consumption at idle state, a 32.768 kHz crystal can be added on the host board. Connection to an external NFC (Near Field Communication) antenna is provided.

BC840 Block Diagram

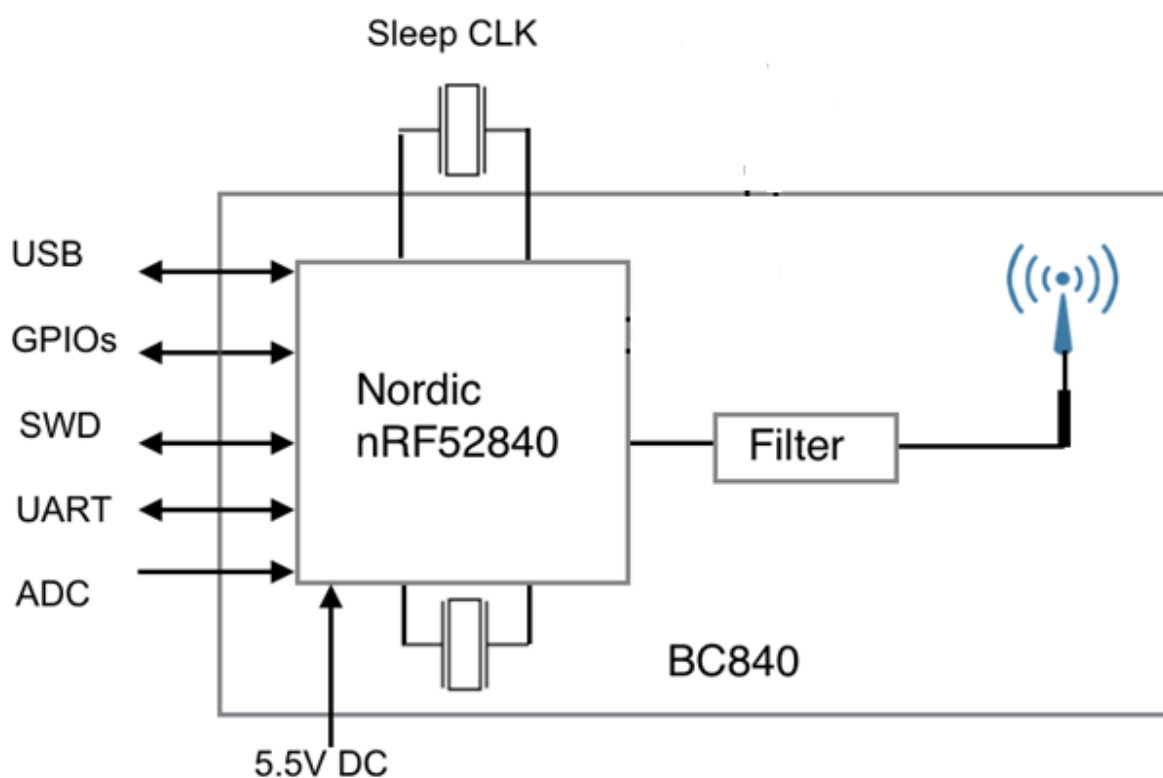

BlueNor BC840M is a sister module of BC840. The physical size is slightly larger to accommodate longer range PCB trace antenna. BC840E is with an u.FL connector for an external antenna.

BC840 and BC840M common features:

- nRF52840 CCAA with Cortex M4F MCU
- 1MB flash, 256 KB RAM
- Supports NFC
- Integrated PCB trace antenna.

- 64 LGA pins
- 48 GPIOs

BC840

- Estimated range is 10 meters.
- Size: 7.0x9.0x1.5 mm.

BC840M

- Estimated range is 1000 meters.
- Size: 7.0x12.0x1.5mm. Antenna area width is 10.0mm.

BC840E

- With an u.FL connector for external antenna.
- Size: 7.0x12.0x1.5 mm.

2. Codes Development Using Nordic Tools

Development tools by Nordic and other third party development tools recommended by Nordic should be used .

Easy, fast and safe code development

Nordic development environment for nRF52840 offers a clean separation between application code development and embedded protocol stacks. This means compile, link and run time dependencies with the embedded stack and associated debugging challenges are removed. The Bluetooth low energy and ANT stack is a pre-compiled binary, leaving application code to be compiled stand-alone. The embedded stack interface uses an asynchronous and event driven model removing the need for RTOS frameworks.

Over-The-Air DFU

The nRF52840 is supported by an Over-The-Air Device Firmware Upgrade (OTA DFU) feature. This allows for in the field updates of application software and SoftDevice.

SoftDevices

The Nordic protocol stacks are known as SoftDevices and complement the nRF52 Series SoCs. All nRF52 Series are programmable with software stacks from Nordic. This bring maximum flexibility to application development and allows the latest stack version to be programmed into the SoC.

SoftDevices available from Nordic:

S140: Bluetooth low energy concurrent central/peripheral/observer/broadcaster stack.

Development Tools

Nordic Semiconductor provides a complete range of hardware and software development tools for the nRF52 Series devices. nRF52 DK board is recommended for firmware development.

Nordic software development tools can be downloaded from the following webpage.

http://infocenter.nordicsemi.com/index.jsp?topic=/com.nordic.infocenter.nrf52/dita/nrf52/development/nrf52_dev_kit.html&cp=1_1

3. Product Descriptions

Brief description of nRF52840 SoC is provided. For full description of the SoC, please download from Nordic Semiconductor website.

<https://www.nordicsemi.com/eng/Products/Bluetooth-low-energy>

Block Diagram of nRF52840

BC840/M/E, Compact BLE 5, Thread, Zigbee Modules Ver 0.30 Dec. 2018

The following is a block diagram of Nordic nRF52840 Bluetooth Low Energy (BLE) SoC. Arrows with white

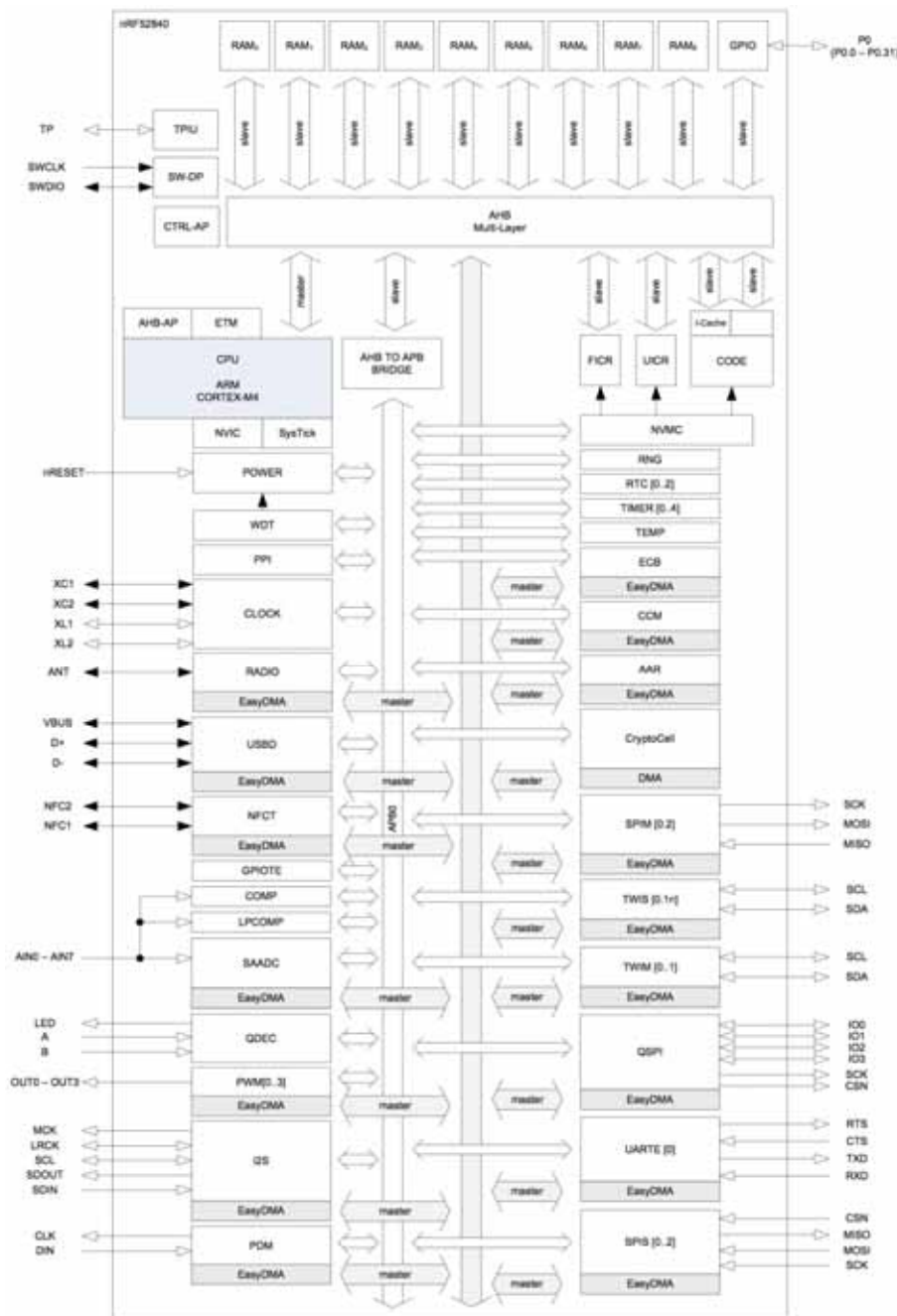

heads indicate signals that share physical pins with other signals.

The 32 bit ARM Cortex M4F MCU with hardware supports for DSP instructions and floating point operations, code density and execution speed are higher than other Cortex M MCU. The Programmable Peripheral Interconnect (PPI) system provides a 20-channel bus for direct and autonomous system peripheral communication without CPU intervention. This brings predictable latency times for peripheral to peripheral interaction and power saving benefits associated with leaving CPU idle. The device has 2 global power modes

BC840/M/E, Compact BLE 5, Thread, Zigbee Modules Ver 0.30 Dec. 2018

ON/OFF, but all system blocks and peripherals have individual power management control which allows for an automatic switching RUN/IDLE for system blocks based only on those required/not required to achieve particular tasks.

The radio supports Bluetooth low energy and ANT. Output power is scalable from a maximum of +8dBm down to -20 dBm in 4dB steps. Sensitivity is increased to -96 dBm to -89 dBm, depending on data rate. Sensitivity for BLE is -96 dBm, and -92.5 dBm for ANT.

The NFC block supports NFC-A tags with proximity detection and Wake-on-field from low power mode. The NFC enables Out-Of-Band (OOB) Bluetooth pairing of devices and thus greatly simplifying deployment.

ARM Trustzone CryptoCell 310

ARM® TrustZone® CryptoCell-310co-processor is a security subsystem which provides Root of Trust (RoT) and cryptographic services for a device. CryptoCell services are available to the application through a software library API, not

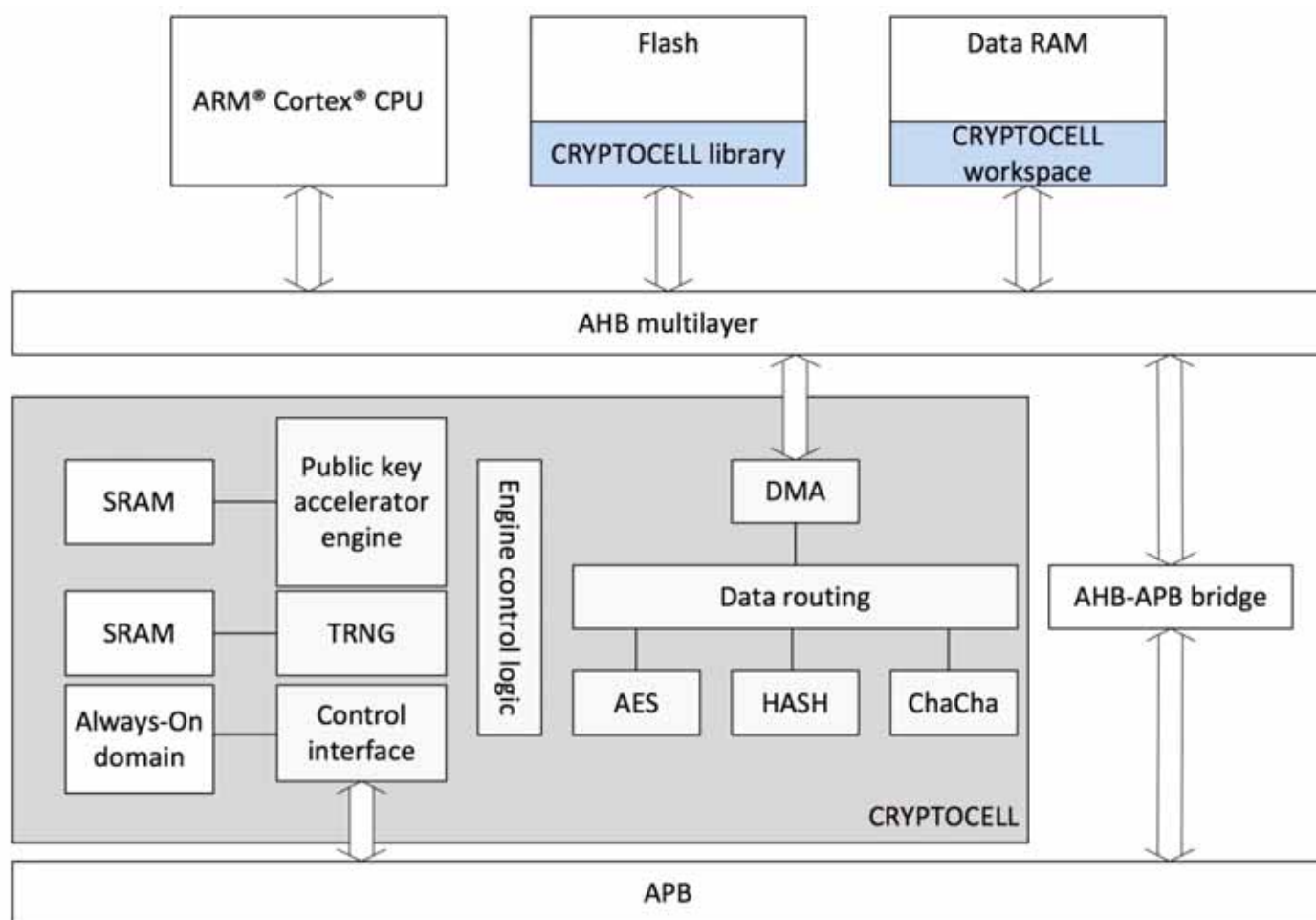

a hardware register interface.

The following cryptographic features are provided.

- FIPS-140-2 certified True Random Number Generator (TRNG)

- RSA asymmetric encryption
 - Up to 2048 bit key size
 - PKCS#1 v2.1/v1.5
 - Optional CRT support
- Elliptic curve cryptography (ECC)
 - NIST FIPS 186-4 recommended curves using pseudo-random parameters, up to 521 bits:
 - Prime field: P-192, P-224, P-256, P-384, P-521
 - SEC 2 recommended curves using pseudo-random parameters, up to 521 bits:
 - Prime field: P-160, P-192, P-224, P-256, P-384, P-521
 - Koblitz curves using fixed parameters, up to 256 bits:
 - Prime field: P-160, P-192, P-224, P-256
 - Edwards/Montgomery curves:
 - Ed25519, Curve 25519
 - ECDH/ECDSA support
- Secure remote password protocol (SRP)
 - Up to 3072 bit operations
- Hashing functions
 - SHA-1, SHA-2 up to 256 bit size
 - keyed-hash message authentication code (HMAC)
- AES symmetric encryption
 - General purpose AES engine (encrypt/decrypt, sign/verify)
 - 128 bit key size
 - Supported encryption modes: ECB, CBC, CMAC/CBC-MAC, CTR, CCM/CCM*.
- ChaCha20/Poly1305 symmetric encryption
 - Supported keyed size: 128 and 256 bits
 - Authenticated encryption with associated data (AEAD) mode



BC840/M/E, Compact BLE 5, Thread, Zigbee Modules Ver 0.30 Dec. 2018

Mechanical Drawings

The followings are mechanical drawings of BC840. Size is 7.0x9.0mm. It has 64 LGA pins on a 8x8 matrix, top

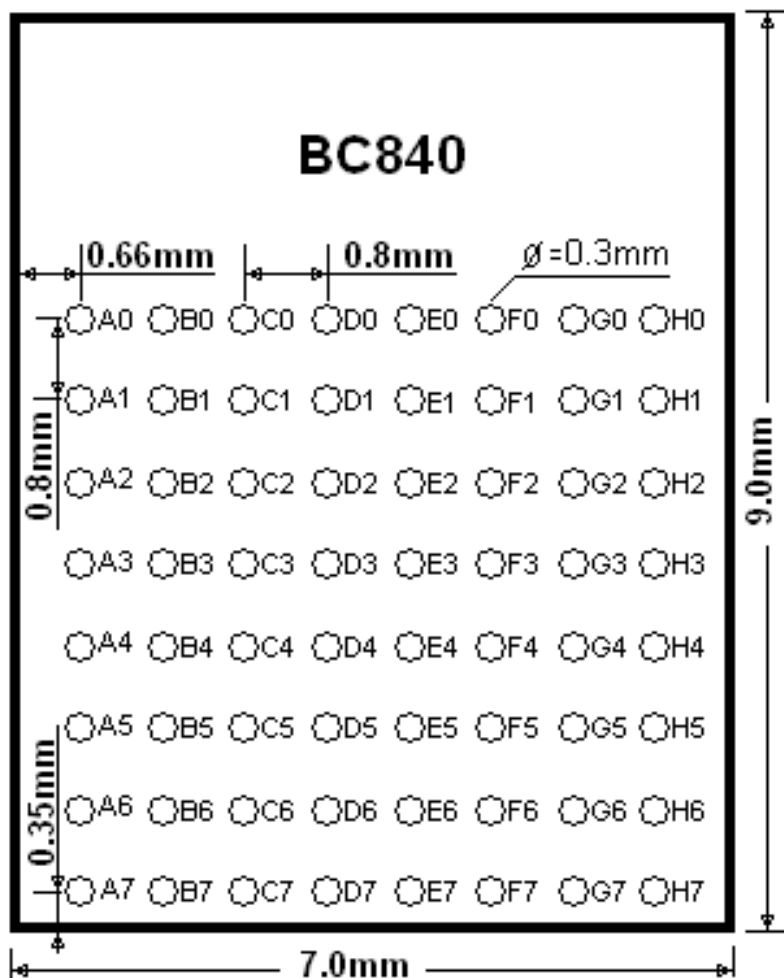

view of module:

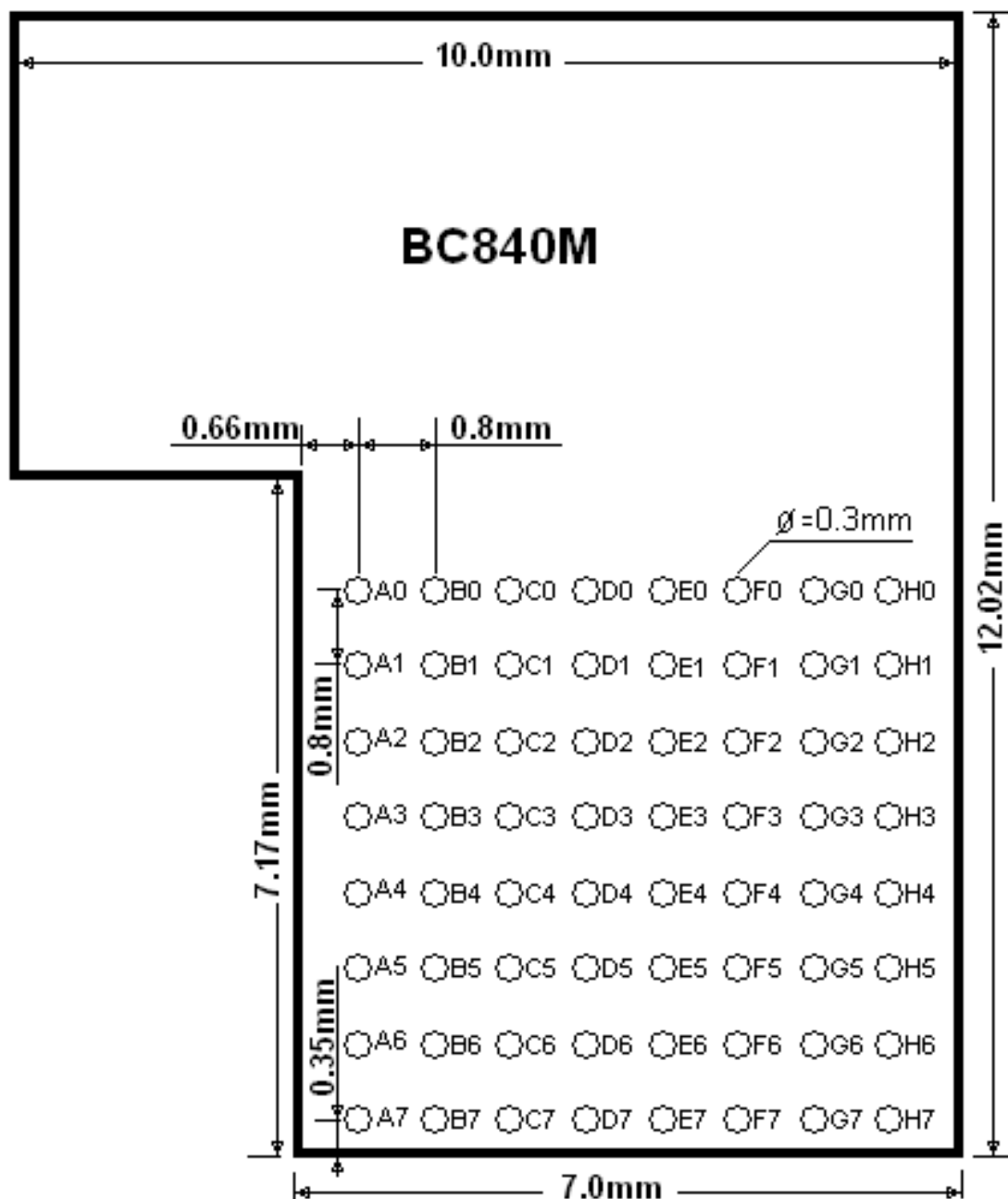

BC840M mechanical drawings, top view.

BC840/M/E, Compact BLE 5, Thread, Zigbee Modules Ver 0.30 Dec. 2018

Pin Assignments of BC840, BC840M, and BC840E

The followings are BC840/BC840M/BC820E pin assignment. Pin functions are in a table in next section. Please refer to Nordic nRF52840 Product Specifications for detailed descriptions and features supported.

<https://www.nordicsemi.com/eng/Products/nRF52840>

BC840, BC840M, and BC840E pin assignments

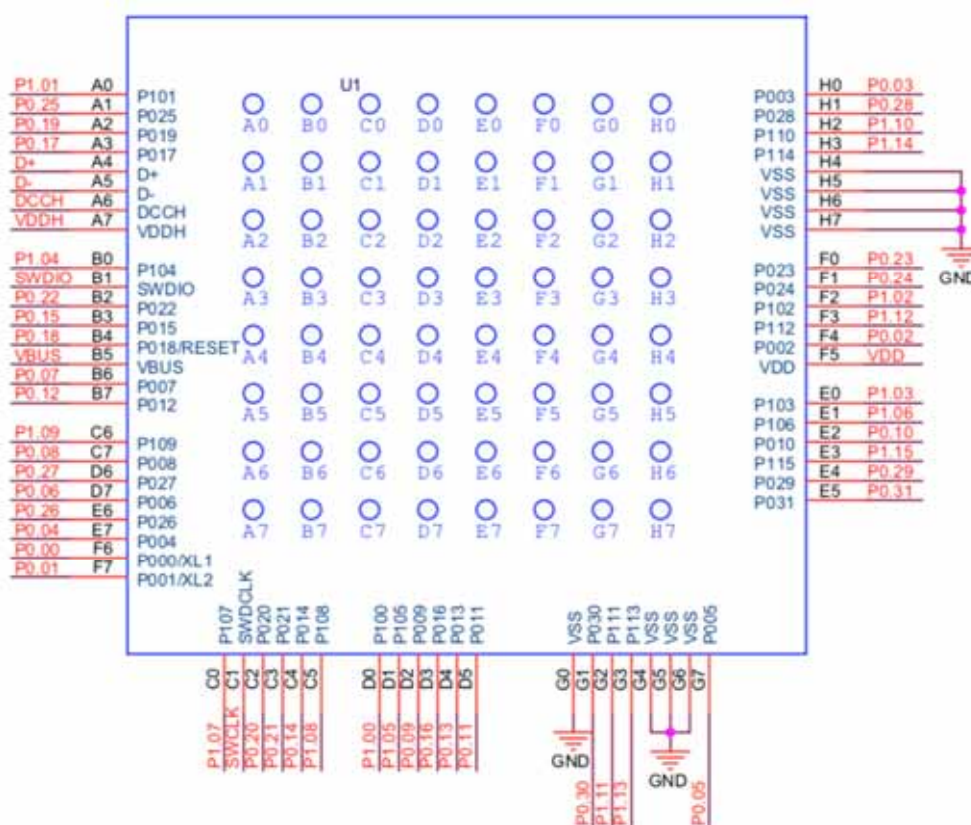

BC840	52840 CKAA	pin name	Descriptions
pin#	pin#	pin name	Descriptions
A0	J1	P1.01	GPIO
A1	K2	P0.25	GPIO
A2	K4	P0.19	GPIO
A3	J6	P0.17	GPIO
A4	K8	D+	USB D+
A5	J8	D-	USB D-
A6	H9	DCCH	DC to DC converter output
A7	J10	VDDH	High Voltage Power Supply
B0	H1	P1.04	GPIO
B1	J2	SWDIO	Serial Wire Debug Data I/O
B2	K3	P0.22	GPIO

BC840/M/E, Compact BLE 5, Thread, Zigbee Modules Ver 0.30 Dec. 2018

B3	K7	P0.15	GPIO
B4	K6	P0.18	GPIO P0.18/reset
B5	J9	VBUS	5V DC power for USB 3.3V regulator
B6	F9	P0.07	GPIO
B7	G10	P0.12	GPIO
C0	G1	P1.07	GPIO
C1	H2	SWDCLK	Serial Wire Debug clock input
C2	J5	P0.20	GPIO
C3	J4	P0.21	GPIO
C4	J7	P0.14	GPIO
C5	G9	P1.08	GPIO
C6	F10	P1.09	GPIO
C7	E10	P0.08	GPIO
D0	J3	P1.00	GPIO
D1	G2	P1.05	GPIO
D2	F1	P0.09	GPIO, NFC antenna connection
D3	H6	P0.16	GPIO
D4	H7	P0.13	GPIO
D5	H8	P0.11	GPIO
D6	D9	P0.27	GPIO, configured as I2C SCL on EV-BC840
D7	E9	P0.06	GPIO
E0	F3	P1.03	GPIO
E1	E3	P1.06	GPIO
E2	E2	P0.10	GPIO, NFC antenna connection
E3	C6	P1.15	GPIO
E4	C7	P0.29/AIN5	GPIO, analog input 5
E5	C8	P0.31/AIN6	GPIO, analog input 6
E6	C9	P0.26/SDA	GPIO, configured as I2C SDA on EV-BC840
E7	C10	P0.04/AIN2	GPIO, analog input 2
F0	H5	P0.23	GPIO
F1	H4	P0.24	GPIO
F2	G3	P1.02	GPIO
F3	C5	P1.12	GPIO
F4	B6	P0.02/AIN0	GPIO, analog input 0
F5	B8	VDD	DC supply in, 1.7 to 3.6V
F6	B9	P0.00/XL1	GPIO, connection for 32.768 kHz sleep crystal
F7	B10	P0.01/XL2	GPIO, connection for 32.768 kHz sleep crystal
G0	B7	GND	Ground
G1	A7	P0.30/AIN7	GPIO, analog input 7
G2	A3	P1.11	GPIO

G3	A4	P1.13	GPIO
G4		GND	Ground
G5		GND	Ground
G6		GND	Ground
G7	D10	P0.05/AIN3	GPIO, analog input 3
H0	A5	P0.03/AIN1	GPIO, analog input 1
H1	A6	P0.28/AIN4	GPIO, analog input 4
H2	B4	P1.10	GPIO
H3	B5	P1.14	GPIO
H4		GND	Ground
F5		GND	Ground
H6		GND	Ground
H7		GND	Ground

Pin Function

Mounting BC840 and BC840M on the Host PCB

The following figure shows recommended mounting of BC840 and BC840M module on the host PCB.

- For the best Bluetooth range performance, the antenna area of BC840M module shall extend 5.5 mm outside the edge of host PCB board, or 5.5 mm outside the edge of a ground plane.
- For the best Bluetooth range performance, the antenna area of BC840 module shall extend 2.5 mm outside the edge of host PCB board, or 2.5 mm outside the edge of a ground plane.
- The next choice is to place BC840M on a corner of host PCB, the antenna area shall extend 5.5 mm from the edge of ground plane. Ground plane shall be at least 5 mm from the edge of the antenna area of module.
- The next choice is to place BC840 on a corner of host PCB, the antenna area shall extend 2.5 mm from the edge of ground plane. Ground plane shall be at least 5 mm from the edge of the antenna area of module.
- We don't recommend mounting BC840 module in the middle of a host PCB.

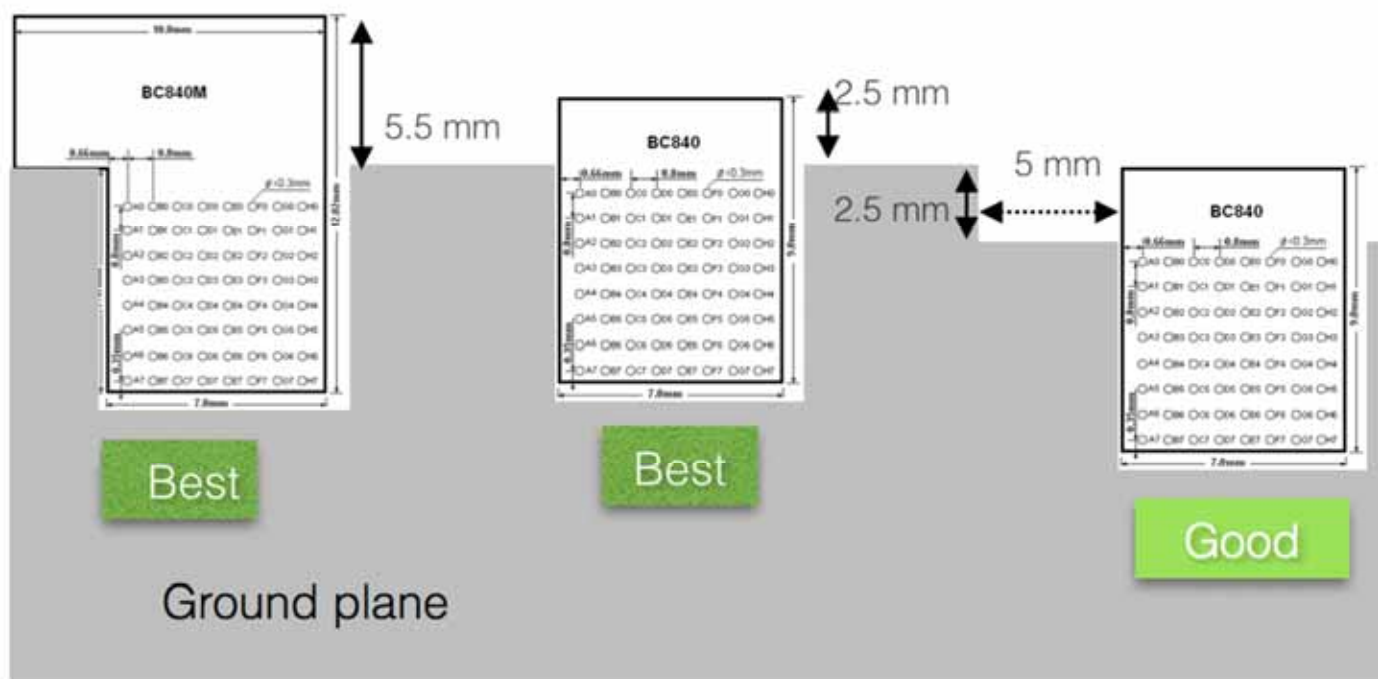

For the best Bluetooth range performance, keep all external metal at least 30mm from the antenna area.

Host Board Layout

Library components for some PCB layout software are available. Or, it can be extracted from EV-BC840 evaluation board Gerber files. Gerber files can be downloaded from:

<http://www.fanstel.com/download-document/>.

4. BC840 Evaluation Board

An evaluation board consists of the followings:

- Mini USB cable
- Evaluation board

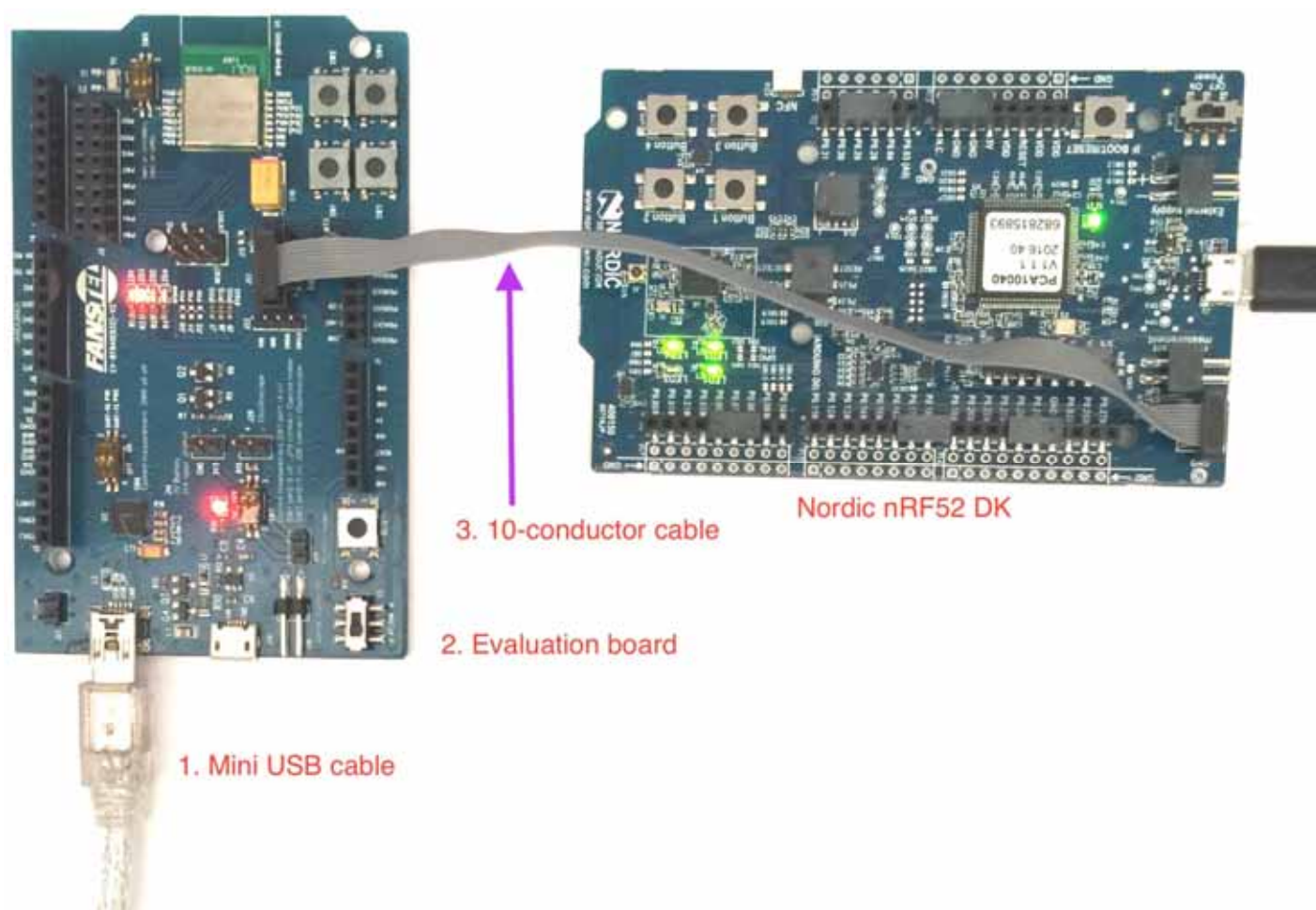

- 10-conductor cable for connection to Nordic nRF52 DK (DK is not included)

Nordic Development Tools

A Nordic nRF52840 DK is recommended for programming this evaluation board. Nordic development tools can be downloaded from:

<https://www.nordicsemi.com/eng/Products/nRF52840>

Many application examples can be downloaded from Nordic website.

BC840/M/E, Compact BLE 5, Thread, Zigbee Modules Ver 0.30 Dec. 2018

Some firmware, Android OS, and iOS app codes can be downloaded from **Bluetooth 5 Codes section** of this Fanstel webpage.

<http://www.fanstel.com/download-document/>

BT840 firmware can be used in all nRF52840 modules, e.g., BT840, BT840F, BT840E, BC840, and BC840M.

Android OS Apps

The following Android OS apps are available for download from Google Play Store:

BlueNor nrf5x: to use with Bluetooth 5 stacks, AT commands, or Slave firmware. Master firmware does not connect to a smartphone. Source codes can be downloaded from <http://www.fanstel.com/download-document/>

BlueNor Mesh: to use with BlueNor mesh firmware to send command to any node in a mesh. Node number is displayed when acknowledgement is received. Source codes will be uploaded to Fanstel website when supporting Bluetooth 5.

iOS Apps

The following iOS apps can be downloaded from Apple APP Store.

BlueNor Mesh: to use with BlueNor mesh firmware to send command to any node in a mesh. Node number is displayed when acknowledgement is received.

BlueNor nrf5x firmware, apps, and source codes will be uploaded when ready.



BC840 Evaluation Board Schematics

Evaluation board can be used as a reference design for using modules..

Suggestion for Battery Power Application

Standby current consumption is important for battery-powered product. We suggest adding a 32.768 kHz crystal and 2 capacitors on host board. The 32MHz main clock won't be active at idle state to save power.

Two inductors required for on-board DC to DC converter are inside BC840 and BC840M. You can enable DCDC converter to have lower power consumption.

5. Production

Preloaded Firmware

Production testing codes are not erased before shipping from factory. To load your firmware, please erase the entire chip and re-program using instruction below.

```
//program BT840 Bootloader+Softdevice+Application hex
```

```
nrfjprog -f NRF52 --program BT840_AT_3in1PC181113.hex --chiperase --reset
```

```
//The file BT840_AT_3in1PC181113.hex = softdevice S140v6.1.1+BT840_AT_UARTwithout32K+bootloader
```

AT Command Codes

Begin in November 2018, we use AT command codes for production testing. Up to date codes can be downloaded from:

<https://www.fanstel.com/download-document/>

You can erase and reprogram with your codes. Or, use AT command codes as preloaded.

If you need a special version of codes, programming services are available with MOQ and programming charges.

Soldering Temperature-Time Profile for Re-Flow Soldering

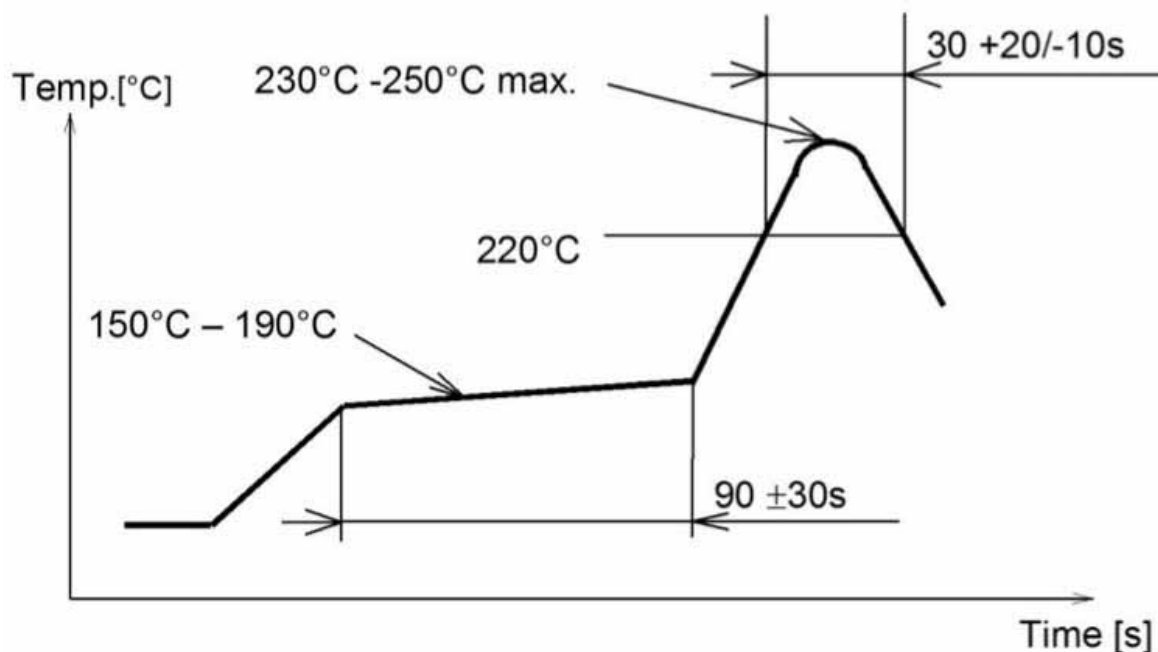

Maximum number of cycles for re-flow is 2. No opposite side re-flow is allowed due to module weight.

Cautions, Design Notes, and Installation Notes

Failure to follow the guidelines set forth in this document may result in degrading of the product's functions and damage to the product.

Design Notes

- (1) Follow the conditions written in this specification, especially the control signals of this module.
- (2) The supply voltage has to be free of AC ripple voltage (for example from a battery or a low noise regulator output). For noisy supply voltages, provide a decoupling circuit (for example a ferrite in series connection and a bypass capacitor to ground of at least 47uF directly at the module).
- (3) This product should not be mechanically stressed when installed.
- (4) Keep this product away from heat. Heat is the major cause of decreasing the life of these products.
- (5) Avoid assembly and use of the target equipment in conditions where the products' temperature may exceed the maximum tolerance.
- (6) The supply voltage should not be exceedingly high or reversed. It should not carry noise and/or spikes.
- (7) this product away from other high frequency circuits.

Notes on Antenna and PCB Layout

- (1) Don't use a module with internal antenna inside a metal case.

(2) For PCB layout:

- Avoid running any signal line below module whenever possible,
- No ground plane below antenna,
- If possible, cut-off the portion of main board PCB below antenna.

Installation Notes

- (1) Reflow soldering is possible twice based on the time-temperature profile in this data sheets. Set up the temperature at the soldering portion of this product according to this reflow profile.
- (2) Carefully position the products so that their heat will not burn into printed circuit boards or affect the other components that are susceptible to heat.
- (3) Carefully locate these products so that their temperatures will not increase due to the effects of heat generated by neighboring components.
- (4) If a vinyl-covered wire comes into contact with the products, then the cover will melt and generate toxic gas, damaging the insulation. Never allow contact between the cover and these products to occur.
- (5) This product should not be mechanically stressed or vibrated when reflowed.
- (6) If you want to repair your board by hand soldering, please keep the conditions of this chapter.
- (7) Do not wash this product.
- (8) Refer to the recommended pattern when designing a board.
- (9) Pressing on parts of the metal cover or fastening objects to the metal will cause damage to the unit.
- (10) For more details on LGA (Land Grid Array) soldering processes refer to the application note.

Usage Condition Notes

- (1) Take measures to protect the unit against static electricity. If pulses or other transient loads (a large load applied in a short time) are applied to the products, check and evaluate their operation before assembly on the final products.
- (2) Do not use dropped products.
- (3) Do not touch, damage or soil the pins.
- (4) Follow the recommended condition ratings about the power supply applied to this product.
- (5) Electrode peeling strength: Do not add pressure of more than 4.9N when soldered on PCB
- (6) Pressing on parts of the metal cover or fastening objects to the metal cover will cause damage.
- (7) These products are intended for general purpose and standard use in general electronic equipment, such as home appliances, office equipment, information and communication equipment.

Storage Notes

- (1) The module should not be stressed mechanically during storage.
- (2) Do not store these products in the following conditions or the performance characteristics of the product, such as RF performance will be adversely affected:
 - Storage in salty air or in an environment with a high concentration of corrosive gas.
 - Storage in direct sunlight
 - Storage in an environment where the temperature may be outside the range specified.
 - Storage of the products for more than one year after the date of delivery storage period.
- (3) Keep this product away from water, poisonous gas and corrosive gas.
- (4) This product should not be stressed or shocked when transported.
- (5) Follow the specification when stacking packed crates (max. 10).

Safety Conditions

These specifications are intended to preserve the quality assurance of products and individual components. Before use, check and evaluate the operation when mounted on your products. Abide by these specifications, without deviation when using the products. These products may short-circuit. If electrical shocks, smoke, fire, and/or accidents involving human life are anticipated when a short circuit occurs, then provide the following failsafe functions, as a minimum.

- (1) Ensure the safety of the whole system by installing a protection circuit and a protection device.
- (2) Ensure the safety of the whole system by installing a redundant circuit or another system to prevent a dual fault causing an unsafe status.

Other Cautions

- (1) This specification sheet is copyrighted. Reproduction of this data sheet is permissible only if reproduction is without alteration and is accompanied by all associated warranties, conditions, limitations, and notices.
- (2) Do not use the products for other purposes than those listed.
- (3) Be sure to provide an appropriate failsafe function on your product to prevent an additional damage that may be caused by the abnormal function or the failure of the product.
- (4) This product has been manufactured without any ozone chemical controlled under the Montreal Protocol.
- (5) These products are not intended for other uses, other than under the special conditions shown below. Before using these products under such special conditions, check their performance and reliability under the said special conditions carefully to determine whether or not they can be used in such a manner.

BC840/M/E, Compact BLE 5, Thread, Zigbee Modules Ver 0.30 Dec. 2018

- In liquid, such as water, salt water, oil, alkali, or organic solvent, or in places where liquid may splash.
 - In direct sunlight, outdoors, or in a dusty environment
 - In an environment where condensation occurs.
 - In an environment with a high concentration of harmful gas.
- (6) If an abnormal voltage is applied due to a problem occurring in other components or circuits, replace these products with new products because they may not be able to provide normal performance even if their electronic characteristics and appearances appear satisfactory.
- (7) When you have any question or uncertainty, contact Fanstel.

Packaging

Production modules are delivered in reel, 1000 modules in each reel.

FCC LABEL

The Original Equipment Manufacturer (OEM) must ensure that the OEM modular transmitter must be labeled with its own FCC ID number. This includes a clearly visible label on the outside of the final product enclosure that displays the contents shown below. If the FCC ID is not visible when the equipment is installed inside another device, then the outside of the device into which the equipment is installed must also display a label referring to the enclosed equipment

The end product with this module may subject to perform FCC part 15 unintentional emission test requirement and be properly authorized.

This device is intended for OEM integrator only.

Revision History

- September 2018 Version 0.20: initial draft release.



6.Contact Us

United States:

Fanstel Corp.

7466 E. Monte Ctisto Ave. Scottsdale AZ 85260

Tel. 1 480-948-4928

Fax. 1-480-948-5459

Email: module@fanstel.com

Website: www.fanstel.com

Taiwan:

Fanstel Corp.

10F-10, 79 Xintai Wu Road

Xizhu, New Taipei City, Taiwan 22101

泛世公司

臺灣省新北市汐止區新臺五路 79 號 10 樓之 10, 22101

Tel. 886-2-2698-9328

Fax. 886-2-2698-4813

Email: tp@fanstel.com

Website: www.fanstel.com

China:

Fanstel Technologies Corp.

11 Jiale Street

Ping-Dih, Long-Gang, Shen Zhen, GD 518117

泛世康科技(深圳)有限公司

廣東省深圳市龍崗區坪地鎮佳樂街 11 號

Tel. 86-755-8409-0928

Fax. 86-755-8409-0973

QQ. 3076221086

Email: sz@fanstel.com

Website: www.fanstel.com

Federal Communications Commission (FCC) Statement

15.21

You are cautioned that changes or modifications not expressly approved by the part responsible for compliance could void the user's authority to operate the equipment.

15.105(b)

This equipment has been tested and found to comply with the limits for a Class B digital device, pursuant to part 15 of the FCC rules. These limits are designed to provide reasonable protection against harmful interference in a residential installation. This equipment generates, uses and can radiate radio frequency energy and, if not installed and used in accordance with the instructions, may cause harmful interference to radio communications. However, there is no guarantee that interference will not occur in a particular installation. If this equipment does cause harmful interference to radio or television reception, which can be determined by turning the equipment off and on, the user is encouraged to try to correct the interference by one or more of the following measures:

- Reorient or relocate the receiving antenna.
- Increase the separation between the equipment and receiver.
- Connect the equipment into an outlet on a circuit different from that to which the receiver is connected.
- Consult the dealer or an experienced radio/TV technician for help.

This device complies with Part 15 of the FCC Rules. Operation is subject to the following two conditions:

- 1) this device may not cause harmful interference, and
- 2) this device must accept any interference received, including interference that may cause undesired operation of the device.

FCC RF Radiation Exposure Statement

This equipment complies with FCC radiation exposure limits set forth for an uncontrolled environment. This equipment should be installed and operated with minimum distance 20cm between the radiator & your body.

This transmitter must not be co-located or operating in conjunction with any other antenna or transmitter.



BC840/M/E, Compact BLE 5, Thread, Zigbee Modules Ver 0.30 Dec. 2018

Canada, Industry Canada (IC)

This Class B digital apparatus complies with Canadian ICES-003
Cet appareil numérique de classe B est conforme à la norme NMB-003.

This device complies with Industry Canada licence-exempt RSS standard(s). Operation is subject to the following two conditions: (1) this device may not cause interference, and (2) this device must accept any interference, including interference that may cause undesired operation of the

Le présent appareil est conforme aux CNR d'Industrie Canada applicables aux appareils radio exempts de licence. L'exploitation est autorisée aux deux conditions suivantes:

(1) l'appareil ne doit pas produire de brouillage, et

(2) l'utilisateur de l'appareil doit accepter tout brouillage radioélectrique subi, même si le brouillage est susceptible d'en compromettre le fonctionnement.

Canada, avis d'Industry Canada (IC)

"Le présent appareil est conforme aux CNR d'Industrie Canada applicables aux appareils radio exempts de licence. L'exploitation est autorisée aux deux conditions suivantes : (1) l'appareil ne doit pas produire de brouillage, et (2) l'utilisateur de l'appareil doit accepter tout brouillage radioélectrique subi, même si le brouillage est susceptible d'en compromettre le fonctionnement."

Déclaration d'exposition aux radiations:

Cet équipement est conforme aux limites d'exposition aux rayonnements ISED établies pour un environnement non contrôlé. Cet équipement doit être installé et utilisé avec un minimum de 20 cm de distance entre la source de rayonnement et votre corps.

(Modular approval) End Product Labeling:

The final end product must be labeled in a visible area with the following: "Contains IC: 4100A-BC840M".

Caution: Exposure to Radio Frequency Radiation.

To comply with RSS 102 RF exposure compliance requirements

OEM statement

The Original Equipment Manufacturer (OEM) must ensure that the OEM modular transmitter must be labeled with its own FCC ID number. This includes a clearly visible label on the outside of the final product enclosure that displays the contents shown below. If the FCC ID is not visible when the equipment is installed inside another device, then the outside of the device into which the equipment is installed must also display a label referring to the enclosed equipment

The end product with this module may subject to perform FCC part 15 unintentional emission test requirement and be properly authorized.

This device is intended for OEM integrator only