

BlueFan BH661C, Dual Mode Bluetooth Module Ver 1.00 July 2016 draft

BH661 Features

- Processor: Toshiba TC35661
- Bluetooth Classic and BLE (Dual Mode) Support
- On board chip antenna.
- Transmitter power +4 dBm; Receiver sensitivity: -91 dBm.
- Bluetooth: V4.0, GATT profile with high level API commands.
- Bluetooth Classic 2.1 embedded SPP profile with high level API commands
- On board masked ROM and SRAM for reliable operation
- Host Control Interface (HCI) protocols, UART interface
- General Purpose IO
 - SPI interface
 - I²C interface
 - UART interface, 2400bps to 4.33Mbps
 - Wake up interface from sleep and deep sleep modes
- Operation voltage: 1.8V-3.6V
- Current consumption
- Operation Temperature: -40°C to +85°C
- Dimension: 15.6x8.7mm, LGA (Land Grid Array) package, 58 pins.
- Integrated shield to resist EMI
- Approval: FCC, pending



Applications:

- | | |
|--|--|
| <input type="checkbox"/> Access Points | <input type="checkbox"/> Instrumentation |
| <input type="checkbox"/> Industrial Control | <input type="checkbox"/> Automobile |
| <input type="checkbox"/> Medical | <input type="checkbox"/> Sports |
| <input type="checkbox"/> Scanners | <input type="checkbox"/> Proximity |
| <input type="checkbox"/> iOS and Android devices | <input type="checkbox"/> Headset |
| <input type="checkbox"/> Wireless sensors | <input type="checkbox"/> Walkie talkie |
| <input type="checkbox"/> Cable replacement | |

Ordering Information:

module	BH661C-503	BH661C-007, -008
SoC	TC35661-503	TC35661-007, -008
antenna	Chip	Chip
Line of sight range, meters	30	30
sleep clock	external	external
Sizes, mm	11x16.7x1.9	11x16.7x1.9
Eval board	EV-BH661C-503	EV-, -007, -008
FCC ID	pending	pending



BlueFan BH661C, Dual Mode Bluetooth Module Ver 1.00 July 2016 draft

IC ID (Canada)	pending	pending
Availability	in production	made to order



BlueFan BH661C, Dual Mode Bluetooth Module Ver 1.00 July 2016 draft

1. Introduction	4
2. Product Overview	4
3. Hardware Description	5
Mechanical Drawings of BH661C	
Pin Assignments of BH661C	
Pin Functions	
4. UART Interface	6
Features	
Flow Control Function	
UART Baud Rate Setting	
Error Detect Function	
5. Bluetooth Features	8
BH661C-503	
BH661C-008	
6. General Device Requirements and Operation	9
Absolute Maximum Ratings	
Recommended Operating Conditions	
Current Consumption	
7. Software	10
Information Regarding Software Versions	
Software	
8. BH661C Evaluation Board	11
Evaluation Software for Windows PC	
Evaluation Software for MAC	
Android OS App	
iOS App	
Evaluation Board Schematics	
9. FCC	12
10. Soldering Temperature-Time Profile for Re-Flow Soldering	12
11. Cautions	12
12. Packaging	15
13. Contact Us	16

BlueFan BH661C, Dual Mode Bluetooth Module Ver 1.00 July 2016 draft

1. Introduction

BH661C is a dual mode BLE (Bluetooth Low Energy) and Bluetooth Classic module using Toshiba TC35661 SOC.

TC35661 provides Bluetooth™ HCI (Host Control Interface) function specified in Bluetooth™ Core Specifications. The HCI function allows BH661 to be connected to an external host processor for Bluetooth applications.

2. Product Overview

The following is a block diagram of Toshiba BH661. It communicates with a host processor via an UART port. A 26MHz main clock crystal is on board. For lower power consumption in sleep mode, an external 32.768 KHz clock source is required. This module can be wake up by an external signal

An chip antenna is on board.

For ROM code supporting wide band voice, use I²S interface to connect to an external codec.

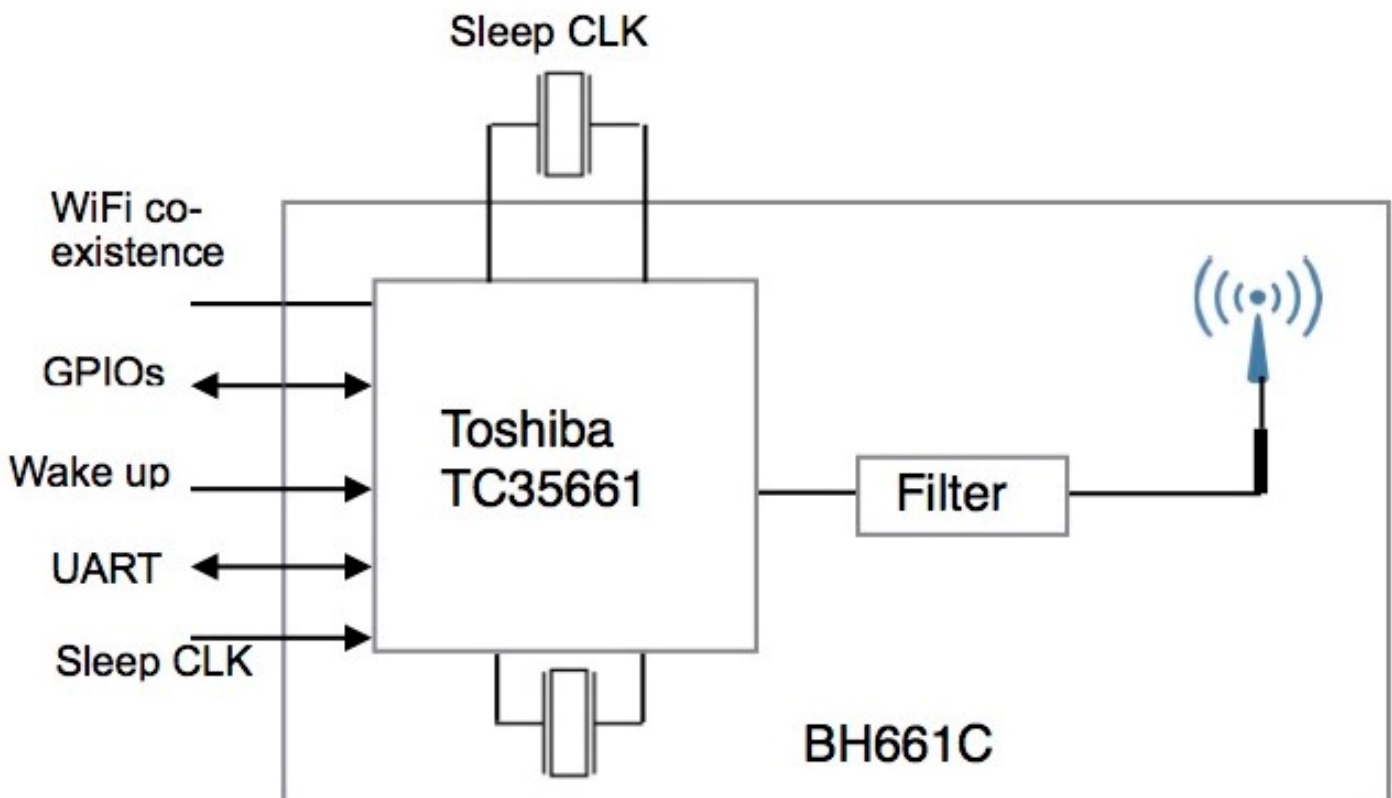

3. Hardware Description

Mechanical Drawings of BH661C

The size of BH661C is 11.1x16.7x1.9mm. The mechanical drawing is shown below.

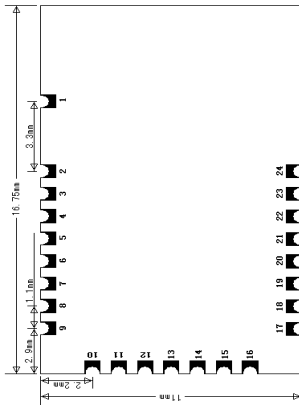

Pin Assignments of BH661C

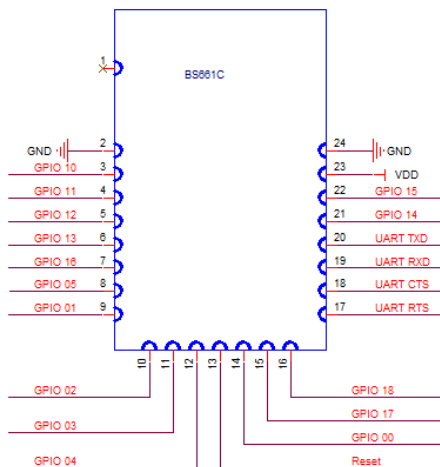

Pin Functions

Pin	Pin name	Descriptions
1	NC	
2	GND	
3	GPIO 10	
4	GPIO 11	
5	GPIO 12	
6	GPIO 13	

BlueFan BH661C, Dual Mode Bluetooth Module Ver 1.00 July 2016 draft

7	GPIO 16	
8	GPIO 05	
9	GPIO 01	GPIO1, set by firmware to Analog to Digital Converter input 0
10	GPIO 02	
11	GPIO 03	
12	GPIO 04	
13	RESET	External reset, active low
14	GPIO 00	GPIO 00, set by firmware to WAKE-UP0
15	GPIO 17	
16	GPIO 18	
17	UART1-RTS	
18	UART1-CTS	
19	UART1-RX	
20	UART1-TX	
21	GPIO 14	GPIO 14, set by firmware to SCL
22	GPIO 15	GPIO 15, set by firmware to SDA
23	VDD	Power supply, 2.0 to 3.6 V
24	GND	Ground

4. UART Interface

Features

- Full duplex 4-wire data transfer: RX, TX, RTSX, CTSX.
- Programmable baud rate: 2400 bps to 4.33 Mbps.
- Data format:
 - ◆ LSB first
 - ◆ 1 start bit
 - ◆ 8 data bit
 - ◆ 1 stop bit
 - ◆ No parity bit
- Error detection:

BlueFan BH661C, Dual Mode Bluetooth Module Ver 1.00 July 2016 draft

- ◆ Character timeout
- ◆ Overrun error
- ◆ Framing error

TC35661 UART interface is used to transfer control command and data and is multiplexed with GPIO pin. After to release reset state, TC35661 software sets UART interface to related GPIO pins. The default bit rate depends on the selection ROM version. (e.g. TC35661-503: 115,2kbps)

Flow Control Function

TC35661 UART interface uses flow control function by hardware signal, Transmit flow control (CTS_X) and receive flow control (RTS_X). Above Figure shows signals input and output direction .

CTS_X input signal is used for UART transmitting. Low input indicates close of the preparation of the other party to receive data and TC35661 executes UART transmitting data if there is data for transmission. In case of input high level, TC35661 stops transmitting by UART frame.

RTS_X input signal is used for UART receiving. Low output indicates request data transmission to UART transmitside device of the other party. TC35661 outputs Low level from RTS_X when being able to receive data and prepares to receive data. Response time of UART transmitting and receiving for flow control signal depends on baud rate and internal process status of frame. It is from 1 frame to 4 frames.

Response time of UART transmitting and receiving for flow control signal depends on baud rate and internal process status of frame. It is from 1 frame to 4 frame.

UART Baud Rate Setting

TC35661 UART interface has a programmable baud rate setting function. The UART baud rate can be set according to the following equation. The baud rate generating clock frequency is set to either 39 MHz or 52 MHz. The over-sampling number is set to an integer that range from 1 to 65535.

$$\text{UART Baud Rate} = \text{Baud rate generating clock frequency} / (\text{Over sampling number} \times \text{dividing ratio})$$

The following table shows examples of UART baud rate setting. The maximum actual baud rate is 4,333,333 bps.

Target baud rate[bps]	Actual baud rate[bps]	clock(MHz)	Over-sampling number	Dividing ratio	Deviation[%]
115,200	116,071	39	12	28	0.7564
115,200	116,071	52	14	32	0.7564
921,600	928,571	39	14	3	0.7564
921,600	928,571	52	14	4	0.7564
1,843,200	1,875,143	52	14	2	0.7564
2,764,800	2,785,714	39	14	1	0.7564

BlueFan BH661C, Dual Mode Bluetooth Module Ver 1.00 July 2016 draft

Target baud rate[bps]	Actual baud rate[bps]	clock(MHz)	Over-sampling number	Dividing ratio	Deviation[%]
4,329,600	4,333,333	52	12	1	0.0862

Error Detect Function

TC35661 UART interface has 3 kinds of error functions.

- Receiver timeout error
- Receiver over run error
- Receiver frame error

Receiver timeout error reports as an error if the receiver frame interval counted by TC35661 internal timer is equal to or greater than a predetermined time

Receiver over run error is reported if UART internal receive frame buffer TC35661 is overflowed.

Receiver frame error is reported if it fails to recognize the unit frame.

5. Bluetooth Features

BH661C-503

- Bluetooth 4.0 with SPP & GATT
- GAP support for SPP
- GATT Server and Client Mode are supported for LE
- Class 2 TX power w/o external PA, improving link robustness.
- Excellent link budget (up to 91 dB), enabling long-range applications.
- GAP peripheral support for LE.

Note:

- For GAP Broadcaster and Peripheral role are supported
- Observer and Central is not supported on GAP
- For GATT Server and Client Mode are supported

BH661C-008

- Bluetooth Classic supporting wide band voice
- Headset profile (HSP)
- Handsfree profile (HFP)
- Class 2 TX power w/o external PA, improving link robustness.
- Excellent link budget (up to 91 dB), enabling long-range applications.

6. General Device Requirements and Operation

Absolute Maximum Ratings

1	Voltage on any digital pin	VDD +/- 0.3 V
2	Operating ambient temperature range	-40 to 85 °C
3	Storage temperature range	-40 to 125 °C
4	Bluetooth RF inputs	10 dBm

Recommended Operating Conditions

		Min	Typ	Max	
1	Power supply voltage	1.7	3.3	3.6	V
2	Maximum ambient operating temperature	-40		85	°C

Current Consumption

Parameters	Condition	Min	Typ	Max	mA
Idle Current	After reset was pulled down.		7.8		mA
Connected Peak Power	Sending DH5 packets. Max. output power			62	mA
Connected Peak Power	Sending DH3 packets. Max. output power			61	mA
Connected Peak Power	Sending DH1 packets. Max. output power			55	mA
Sniff Mode	Sniff Interval =1280ms, Attempt=4, timeout=0		0.18		mA
Sniff Mode	Sniff Interval =500ms, Attempt =4 Timeout=0		0.41		mA
Paging	PageScan interval=1280ms, window=11ms		0.33		mA
Inquiry	InquiryScan interval=1280ms, window=11ms		0.33		mA
BLE Advertising (1 Packet)	Advertising interval=30ms		5.8		mA
BLE Advertising (1 Packet)	Advertising interval=1280ms		0.165		mA

BLE Connected (1 Packet)	Connection interval=105ms		0.913		mA
BLE Connected (1 Packet)	Connection interval=1000ms		0.123		mA

7. Software

Information Regarding Software Versions

The version number of the embedded software can be read out by an extended HCI command. The extended HCI command class < HCI_M2_Message_Get >" allows the reading of the firmware version. PC and MAC software to send HCI commands to read module software version is available from <http://www.fasntel.com>.

Software

The module software offers both embedded Bluetooth HCI (Host Control Interface), extended HCI and TCU (Toshiba Control Unit) Command interfaces via the embedded UART interface

- (1) HCI commands are standard according to Bluetooth standard specifications.
- (2) Extended HCI commands are available for device control, such as RF control, BD_ADDR control, firmware version control, embedded IO control, maintenance tasks etc. Please refer to the "Extension HCI Command Document".
- (3) The BH661-502 includes Toshiba TC35661 with ROM code 502 incorporating Bluetooth stack and SPP profile and BLE GATT profile. The profile application interface is described in the "SPP Command Interface Document" (about 14 commands) and the "Bluetooth Basic Management Command Interface Document" (about 46 commands). The related high level commands are called "TCU" commands. The "SPP Message Sequence Chart Document" and the "Bluetooth Management Message . Sequence Chart Document" describe the logical and sequential procedure to use those commands.
- (4) The BH661-008 includes Toshiba TC35661 with ROM code 008 incorporating Bluetooth Handsfree profile and Headset profile. The profile application interface is described in the "Bluetooth Basic Management Command Interface Document" (about 46 commands). The related high level commands are called "TCU" commands.
- (5) After RESET of the module, the module starts in HCI mode. The "Bluetooth LSI TC35661 Application Note" describes how to start the device and enter into "TCU" mode thereafter.
- (6) Toshiba offers SPP drivers, that allows a further abstraction towards the application software including SPP programming examples. This is documented in the "BT SPP API Specification", the "BT SPP Driver Specification" and the "BT SPP Application Note". The "SPP API" offers a few high-level APIs for LSI initialization, connection setup and communication with a remote SPP device. The user has full control over all LSI features by utilizing the lower-level "SPP Drivers". The drivers take care for issuing commands and data to the LSI and they handle the responses from the TC36661. The "Application Note" includes a SPP programming example and shows the integration with a RTOS." All documents are available on respective Fanstel or Toshiba websites.

8. BH661C Evaluation Board

A quick and easy way to evaluate BH661C is to use a Windows PC or a MAC as the host processor. Connect the development board DVB661C to a PC with an USB cable.

Evaluation Software for Windows PC

Evaluation software for Windows PC can be download from the following link.

<https://dl.dropboxusercontent.com/u/54939426/BlueFanHClwin.rar>

After unzipping, it becomes an executable file. You need to OPEN from a MENU for the first time. Then, you can double click the icon to open.

Evaluation Software for MAC

Evaluation software for MAC can be download from the following link.

<https://dl.dropboxusercontent.com/u/54939426/BlueFanHClmac.zip>

After unzipping, it becomes an executable file. You need to OPEN from a MENU for the first time. Then, you can double click the icon to open

Android OS App

Android OS apps to evaluate communication via SPP and BLE can be downloaded from Google Play Store by searching for [BlueFan](#). This is a very basic app for proving communication between a PC, BH661 module, and an Android device.

iOS App

iOS apps to evaluate communication via BLE can be downloaded from Apple App Store by searching for [BlueFan](#). This is a very basic app for proving communication between a PC, BH661 module, and an Android device.

BlueFan BH661C, Dual Mode Bluetooth Module Ver 1.00 July 2016 draft

9. FCC

(1) the module should not installed and operated simultaneously with other radios except additional RF exposure was evaluated and meeting FCC requirement for simultaneously transmission.

(2) Antenna used should be limited to (Dipole) type with equal or lesser antenna gain.

10. Soldering Temperature-Time Profile for Re-Flow Soldering

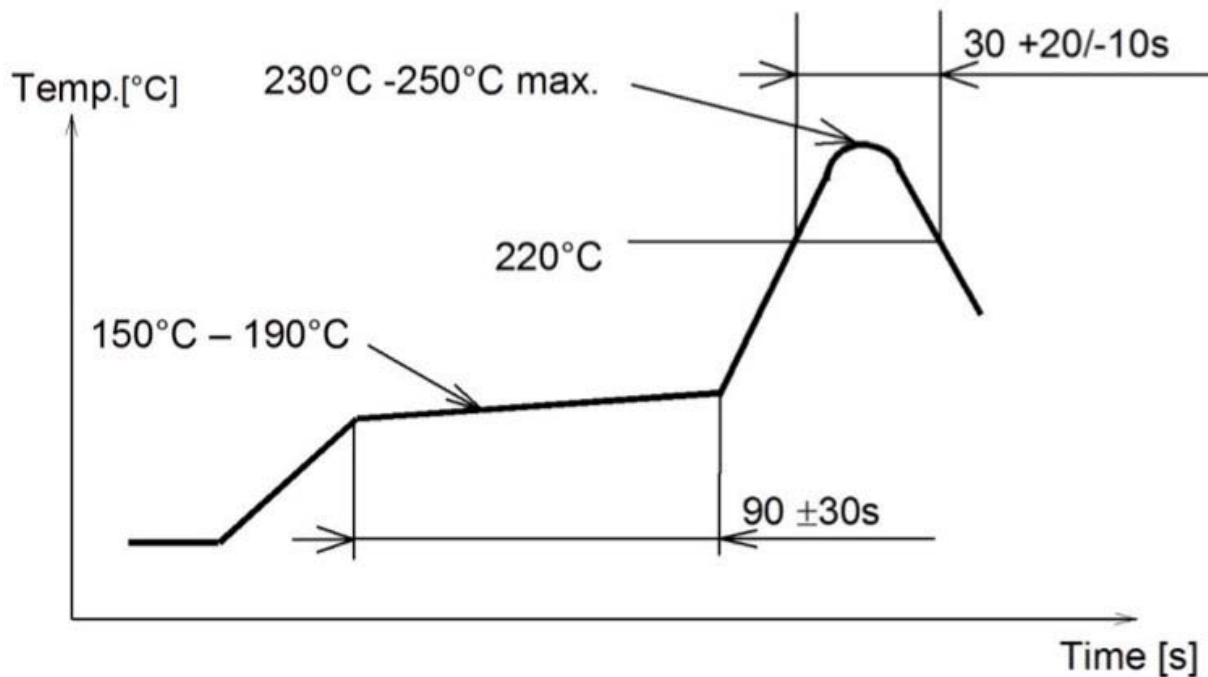

The following temperature profile is suggested for re-flow oven.

11. Cautions

Failure to follow the guidelines set forth in this document may result in degrading of the product's functions and damage to the product.

Design Notes

(1) Follow the conditions written in this specification, especially the control signals of this module.

BlueFan BH661C, Dual Mode Bluetooth Module Ver 1.00 July 2016 draft

- (2) The supply voltage has to be free of AC ripple voltage (for example from a battery or a low noise regulator output). For noisy supply voltages, provide a decoupling circuit (for example a ferrite in series connection and a bypass capacitor to ground of at least 47uF directly at the module).
- (3) This product should not be mechanically stressed when installed.
- (4) Keep this product away from heat. Heat is the major cause of decreasing the life of these products.
- (5) Avoid assembly and use of the target equipment in conditions where the products' temperature may exceed the maximum tolerance.
- (6) The supply voltage should not be exceedingly high or reversed. It should not carry noise and/or spikes.
- (7) this product away from other high frequency circuits.

Notes on Antenna and PCB Layout

- (1) Don't use a module with internal antenna inside a metal case.
- (2) Use a module with external antenna inside a metal case. Antenna must be outside of a metal case.
- (3) For PCB layout:
 - Avoid running any signal line below module whenever possible,
 - No ground plane below antenna,
 - If possible, cut-off the portion of main board PCB below antenna.

Installation Notes

- (1) Reflow soldering is possible twice based on the time-temperature profile in this data sheets. Set up the temperature at the soldering portion of this product according to this reflow profile.
- (2) Carefully position the products so that their heat will not burn into printed circuitboards or affect the other components that are susceptible to heat.
- (3) Carefully locate these products so that their temperatures will not increase due to the effects of heat generated by neighboring components.
- (4) If a vinyl-covered wire comes into contact with the products, then the cover will melt and generate toxic gas, damaging the insulation. Never allow contact between the cover and these products to occur.
- (5) This product should not be mechanically stressed or vibrated when reflowed.
- (6) If you want to repair your board by hand soldering, please keep the conditions of this chapter.
- (7) Do not wash this product.
- (8) Refer to the recommended pattern when designing a board.

BlueFan BH661C, Dual Mode Bluetooth Module Ver 1.00 July 2016 draft

- (9) Pressing on parts of the metal cover or fastening objects to the metal will cause damage to the unit.
- (10) For more details on LGA (Land Grid Array) soldering processes refer to the application note.

Usage Condition Notes

- (1) Take measures to protect the unit against static electricity. If pulses or other transient loads (a large load applied in a short time) are applied to the products, check and evaluate their operation before assembly on the final products.
- (2) Do not use dropped products.
- (3) Do not touch, damage or soil the pins.
- (4) Follow the recommended condition ratings about the power supply applied to this product.
- (5) Electrode peeling strength: Do not add pressure of more than 4.9N when soldered on PCB
- (6) Pressing on parts of the metal cover or fastening objects to the metal cover will cause damage.
- (7) These products are intended for general purpose and standard use in general electronic equipment, such as home appliances, office equipment, information and communication equipment.

Storage Notes

- (1) The module should not be stressed mechanically during storage.
- (2) Do not store these products in the following conditions or the performance characteristics of the product, such as RF performance will be adversely affected:
- Storage in salty air or in an environment with a high concentration of corrosive gas.
 - Storage in direct sunlight
 - Storage in an environment where the temperature may be outside the range specified.
 - Storage of the products for more than one year after the date of delivery storage period.
- (3) Keep this product away from water, poisonous gas and corrosive gas.
- (4) This product should not be stressed or shocked when transported.
- (5) Follow the specification when stacking packed crates (max. 10).

Safety Conditions

These specifications are intended to preserve the quality assurance of products and individual components. Before use, check and evaluate the operation when mounted on your products. Abide by these specifications, without deviation when using the products. These products may short-circuit. If electrical shocks, smoke, fire, and/or accidents involving human life are anticipated when a short circuit occurs, then provide the following failsafe functions, as a minimum.

BlueFan BH661C, Dual Mode Bluetooth Module Ver 1.00 July 2016 draft

- (1) Ensure the safety of the whole system by installing a protection circuit and a protection device.
- (2) Ensure the safety of the whole system by installing a redundant circuit or another system to prevent a dual fault causing an unsafe status.

Other Cautions

- (1) This specification sheet is copyrighted. Reproduction of this data sheet is permissible only if reproduction is without alteration and is accompanied by all associated warranties, conditions, limitations, and notices.
- (2) Do not use the products for other purposes than those listed.
- (3) Be sure to provide an appropriate fail-safe function on your product to prevent an additional damage that may be caused by the abnormal function or the failure of the product.
- (4) This product has been manufactured without any ozone chemical controlled under the Montreal Protocol.
- (5) These products are not intended for other uses, other than under the special conditions shown below. Before using these products under such special conditions, check their performance and reliability under the said special conditions carefully to determine whether or not they can be used in such a manner.
 - In liquid, such as water, salt water, oil, alkali, or organic solvent, or in places where liquid may splash.
 - In direct sunlight, outdoors, or in a dusty environment
 - In an environment where condensation occurs.
 - In an environment with a high concentration of harmful gas.
- (6) If an abnormal voltage is applied due to a problem occurring in other components or circuits, replace these products with new products because they may not be able to provide normal performance even if their electronic characteristics and appearances appear satisfactory.
- (7) When you have any question or uncertainty, contact Fanstel.

12. Packaging

We will deliver the module in the described below.



BlueFan BH661C, Dual Mode Bluetooth Module Ver 1.00 July 2016 draft

13. CONTACT US

United States:

Fanstel Corp.
7466 E. Monte Ctisto Ave. Scottsdale AZ 85260
Tel. 1 480-948-4928
Fax. 1-480-948-5459
Email: module@fanstel.com
Website: www.fanstel.com

Taiwan:

Fanstel Corp.
10F-10, 79 Xintai Wu Road
Xizhu, New Taipei City, Taiwan 22101
泛世公司
臺灣省新北市汐止區新臺五路 79 號 10 樓之 10, 22101
Tel. 886-2-2698-9328
Fax. 886-2-2698-4813
Email: tp@fanstel.com
Website: www.fanstel.com

China:

Fanstel Technologies Corp.
11 Jiale Street
Ping-Dih, Long-Gang, Shen Zhen, GD 518117
泛世康科技(深圳)有限公司
廣東省深圳市龍崗區坪地鎮佳樂街 11 號
Tel. 86-755-8409-0928
Fax. 86-755-8409-0973
QQ. 3076221086
Email: sz@fanstel.com
Website: www.fanstel.com



BlueFan BH661C, Dual Mode Bluetooth Module Ver 1.00 July 2016 draft

Federal Communications Commission (FCC) Statement

15.21

You are cautioned that changes or modifications not expressly approved by the part responsible for compliance could void the user's authority to operate the equipment.

15.105(b)

This equipment has been tested and found to comply with the limits for a Class B digital device, pursuant to part 15 of the FCC rules. These limits are designed to provide reasonable protection against harmful interference in a residential installation. This equipment generates, uses and can radiate radio frequency energy and, if not installed and used in accordance with the instructions, may cause harmful interference to radio communications. However, there is no guarantee that interference will not occur in a particular installation. If this equipment does cause harmful interference to radio or television reception, which can be determined by turning the equipment off and on, the user is encouraged to try to correct the interference by one or more of the following measures:

- Reorient or relocate the receiving antenna.
- Increase the separation between the equipment and receiver.
- Connect the equipment into an outlet on a circuit different from that to which the receiver is connected.
- Consult the dealer or an experienced radio/TV technician for help.

This device complies with Part 15 of the FCC Rules. Operation is subject to the following two conditions:

- 1) this device may not cause harmful interference, and
- 2) this device must accept any interference received, including interference that may cause undesired operation of the device.

FCC RF Radiation Exposure Statement

- 1) This Transmitter must not be co-located or operating in conjunction with any other antenna or transmitter.
- 2) This equipment complies with FCC RF radiation exposure limits set forth for an uncontrolled environment.

This equipment should be installed and operated with a minimum distance of 20 centimeters between the radiator and your body.

To comply with FCC regulations limiting both maximum RF output power and human exposure to RF radiation, the maximum antenna gain including cable loss in a mobile-only exposure condition must not exceed chip

Ant / 1.6dBi

Note: The end product shall has the words "Contains Transmitter Module FCC ID:X8WBH661

Canada, Industry Canada (IC)

This Class B digital apparatus complies with Canadian ICES-003
Cet appareil numérique de classe B est conforme à la norme NMB-003.



BlueFan BH661C, Dual Mode Bluetooth Module Ver 1.00 July 2016 draft

This device complies with Industry Canada licence-exempt RSS standard(s). Operation is subject to the following two conditions: (1) this device may not cause interference, and (2) this device must accept any interference, including interference that may cause undesired operation of the

(Modular approval) End Product Labeling:

The final end product must be labeled in a visible area with the following: “Contains IC:4100A-BH661”.



BlueFan BH661C, Dual Mode Bluetooth Module Ver 1.00 July 2016 draft

Caution: Exposure to Radio Frequency Radiation.

To comply with RSS 102 RF exposure compliance requirements, a separation distance of at least 20 cm must be maintained between the antenna of this device and all persons.

Pour se conformer aux exigences de conformité CNR 102 RF exposition, une distance de séparation d'au moins 20 cm doit être maintenue entre l'antenne de cet appareil et toutes les personnes

To comply with IC regulations limiting both maximum RF output power and human exposure to RF radiation, the maximum antenna gain including cable loss in a mobile-only exposure condition must not internal chip Ant / 1.6dBi

OEM: instruction

Information for the OEMs and Integrators

The following statement must be included with all versions of this document supplied to an OEM or integrator, but should not be distributed to the end user.

This device is intended for OEM integrators only. Please See the full Grant of Equipment document for other restrictions.

Information To Be Supplied to the End User by the OEM or Integrator

The following regulatory and safety notices must be published in documentation supplied to the end user of the product or system incorporating an adapter in compliance with local regulations. Host system must be labeled with "Contains FCCID: X8WBH661 ", FCC ID displayed on label