

INSTALLATION

ID CPR44

ISO14443-A and -B RFID Reader

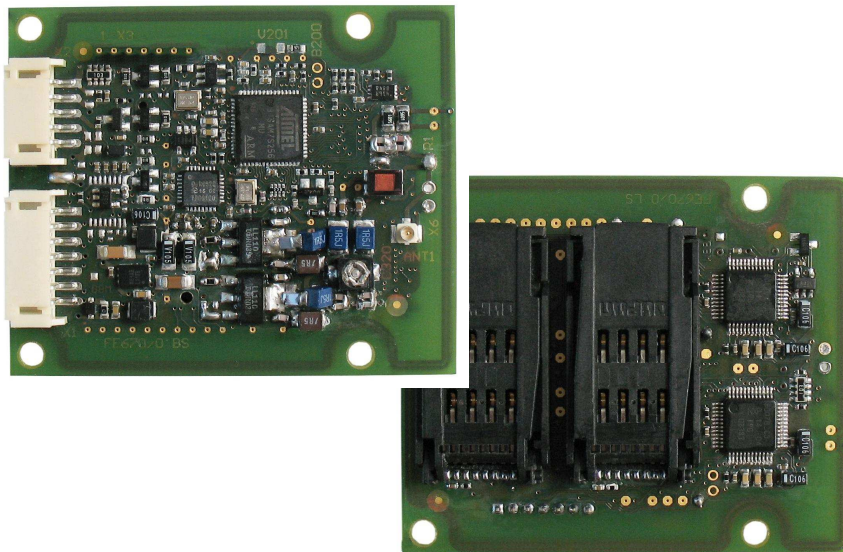

Note

© Copyright 2010 - 2012 by
FEIG ELECTRONIC GmbH
Lange Strasse 4
D-35781 Weilburg
Tel.: +49 6471 3109-0
<http://www.feig.de>

With the edition of this document, all previous editions become void. Indications made in this manual may be changed without previous notice.

The reproduction, distribution and utilization of this document as well as the communication of its contents to others without express authorization is prohibited. Offenders will be held liable for the payment of damages. All rights reserved in the event of the grant of a patent, utility model or design.

Composition of the information in this document has been done to the best of our knowledge. FEIG ELECTRONIC GmbH does not guarantee the correctness and completeness of the details given in this manual and may not be held liable for damages ensuing from incorrect or incomplete information. Since, despite all our efforts, errors may not be completely avoided, we are always grateful for your useful tips.

The instructions given in this manual are based on advantageous boundary conditions. FEIG ELECTRONIC GmbH does not give any guarantee promise for perfect function in cross environments and does not give any guaranty for the functionality of the complete system which incorporates the subject of this document.

FEIG ELECTRONIC call explicit attention that devices which are subject of this document are not designed with components and testing methods for a level of reliability suitable for use in or in connection with surgical implants or as critical components in any life support systems whose failure to perform can reasonably be expected to cause significant injury to a human. To avoid damage, injury, or death, the user or application designer must take reasonably prudent steps to protect against system failures.

FEIG ELECTRONIC GmbH assumes no responsibility for the use of any information contained in this document and makes no representation that they free of patent infringement. FEIG ELECTRONIC GmbH does not convey any license under its patent rights nor the rights of others.

OBID® and OBID i-scan® is a registered trademark of FEIG ELECTRONIC GmbH.
All brand names, trademarks or logos are property of their respective owners.

Contents

1. Safety Instructions / Warning - Read before start-up !	4
2. Characterization ID CPR44.0x-xx	5
3. Installation and wiring	6
3.1. Dimensions	6
3.2. Connection X1, X2 - Vcc and Interface	7
3.3. Digital Outputs	8
3.4. SAM Module	9
3.4.1. Installation of a SAM Card.....	10
3.5. Installation notes	11
3.5.1. Metallic surroundings	11
3.5.2. EMC effects on cables	11
3.5.3. EMC effects from magnetic fields	12
4. Radio Approvals	13
4.1. Europe (CE).....	13
4.2. USA (FCC) and Canada (IC)	14
5. Technical Data	15

1. Safety Instructions / Warning - Read before start-up !

- The device may only be used for the intended purpose designed by for the manufacturer.
- The operation manual should be conveniently kept available at all times for each user.
- Unauthorised changes and the use of spare parts and additional devices which have not been sold or recommended by the manufacturer may cause fire, electric shocks or injuries. Such unauthorised measures shall exclude any liability by the manufacturer.
- The liability-prescriptions of the manufacturer in the issue valid at the time of purchase are valid for the device. The manufacturer shall not be held legally responsible for inaccuracies, errors, or omissions in the manual or automatically set parameters for a device or for an incorrect application of a device.
- Repairs may only be executed by the manufacturer.
- Installation, operation, and maintenance procedures should only be carried out by qualified personnel.
- Use of the device and its installation must be in accordance with national legal requirements and local electrical codes .
- When working on devices the valid safety regulations must be observed.
- **Special advice for carriers of cardiac pacemakers:**
Although this device doesn't exceed the valid limits for electromagnetic fields you should keep a minimum distance of 25 cm between the device and your cardiac pacemaker and not stay in an immediate proximity of the device respective the antenna for some time.

2. Characterization ID CPR44

The reader modules ID CPR44 are designed for data exchange (read and write) with passive transponder according ISO14443 type A and type B and are capable for communication with NFC devices (ISO18092) and supports the mifare classic security functions. The small dimensions and the different available interfaces (RS232-TTL or USB) makes it suitable for an easy integration into terminals, housings and other devices. If the device is connected to an USB host it works as a self-powered device which requires a separate power supply.

The following different types are available:

	CPR44-4SCUSB	CPR44-CUSB
Dimensions L x D x H (mm)	50 x 60 x 13,8	50 x 60 x 7,3
Power supply	5 V / DC	
SAM Socket	4	-
Digital outputs	3	
Interface		
• RS232-TTL	●	
• USB full-speed (12Mbit/s)	●	

ID CPR44-4SCUSB

Reader module with internal antenna. The reader modules ID CPR44-4SCUSB are equipped with 4 sockets for Security Access Modules (SAM) in ID000 format.

ID CPR44-SCUSB

Reader module with internal antenna. The reader modules ID CPR44-SCUSB has no Security Access Modules sockets.

Because of their high performance and a wide range of different configuration parameters the reader modules ID CPR44 is suitable for a lot of applications like access control, ePayment, eTicketing and public transport..

For further details about configuration parameters and commands please refer to the ID CPR44-Family manual (H90700-xe-ID-B.pdf).

3. Installation and wiring

3.1. Dimensions

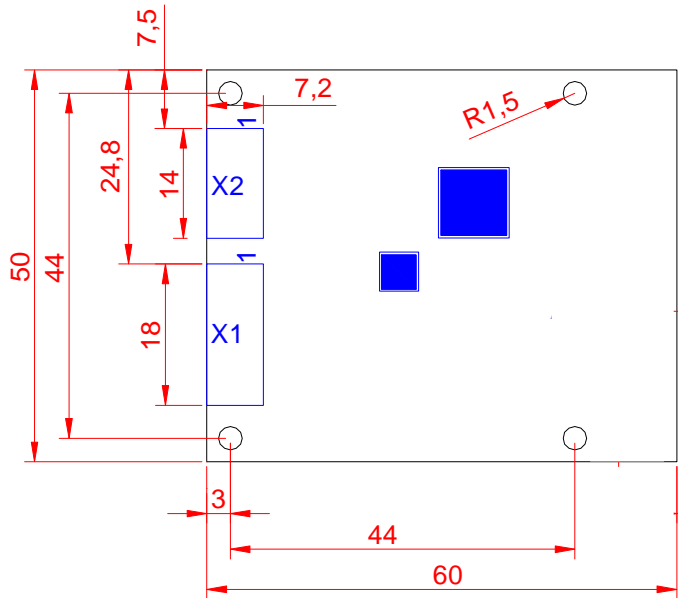

Fig. 2 Top view

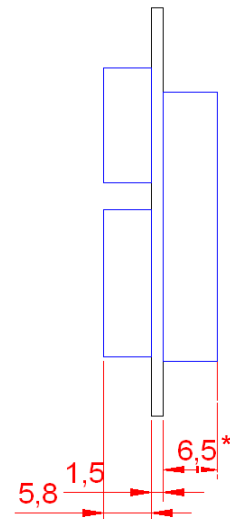

Fig. 1 Side view
(* only types with SAM)

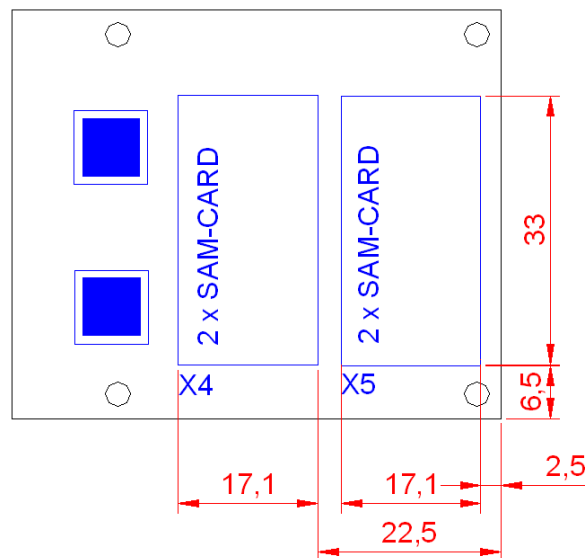

Fig. 3 Button view. Types with SAM

3.2. Connection X1, X2 - Vcc and Interface

The reader can be connected to a RS232-TTL interface and the power supply by using the multi-pin connector X1. The multi-pin connector X2 provide the connection for the USB interface. The device is a self-powered USB device which requires a separate power supply.

The following figure 5 and the table shows the assignment of the pins X1 (7pol.) and X2 (5pol.) Typ "JST PH" RM 2 mm (horizontal).

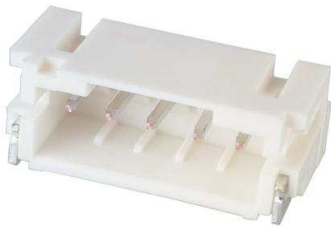

Fig. 4 Plug „JST PH“

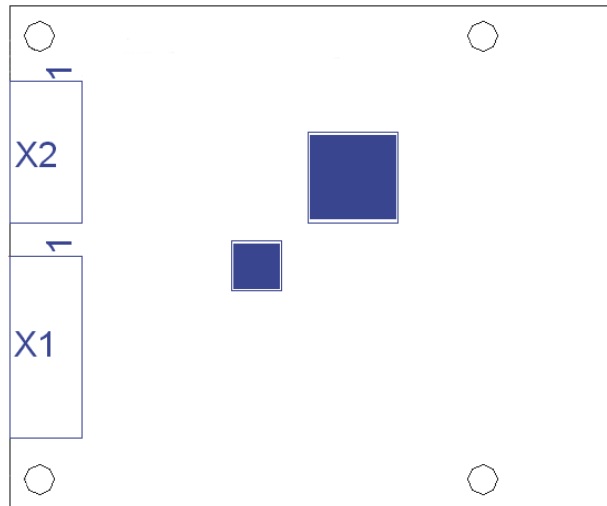

Fig. 5 Plug and connections

X1 Pin-No.	Symbol	ID CPR44
1	OUT1	Digital Output 1
2	OUT2	Digital Output 2
3	OUT3	Digital Output 3
4	GND*	
5	RxD	RS232-TTL
6	TxD	RS232-TTL
7	VCC**	+ 5 V DC \pm 5 %
X2 Pin-No.		
1	Shielding	USB-Cable Shielding
2	GND*	
3	USB-D PLUS	
4	USB-D MINUS	
5	VCC**	+ 5 V DC \pm 5 %

* GND are connected internal directly

** VCC are connected internal directly. Feed-In VCC only at one pin!

NOTICE:

- *The reader has to be supplied by a limited power supply (e.g. NEC Class 2/LPS power supply) according IEC EN 60950, only*
- *Use only regulated power supply's.*
- *The connection cable (RS232TTL, USB, VCC) should be as short as possible and must be shorter than 3 m.*
- *Reversing the polarity of the supply voltage may destroy the device.*
- *Supply voltages outside the specifications may destroy the device.*
- *If switching power supplies are used with the module, be sure that there is adequate filtering.*
- *Noise from the power supply can result in a reduction of the read/write range of the module.*

3.3. Digital Outputs

The Fig. 6 shows the circuit diagram of the digital outputs OUT1 – OUT3. The digital outputs are intended for the connection of external LED's.

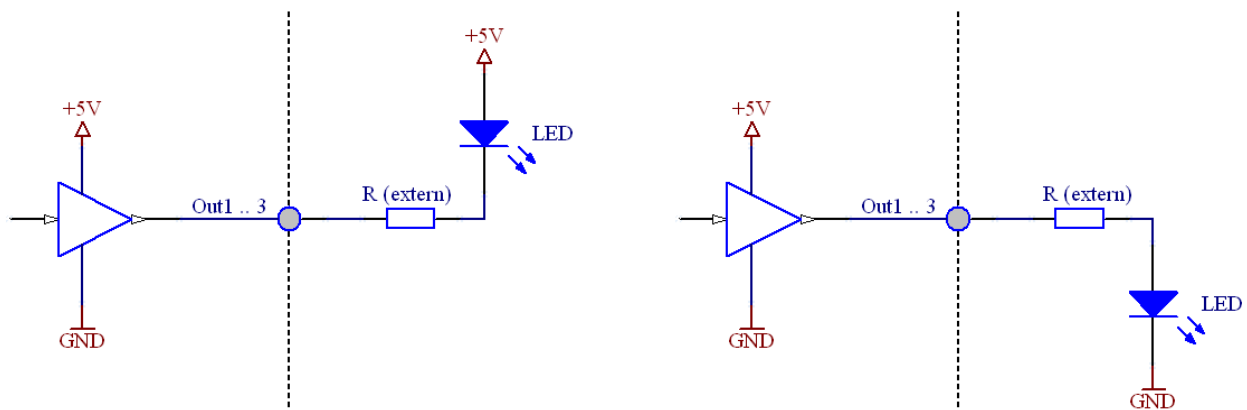

Fig. 6 Wiring of digital outputs OUT1...3

3.4. SAM Module

Fig. 8 shows the position of the 2 SAM connector (double stacked) X4 and X5. Each SAM connector is designed for two ID000 formatted (SIM Karte) SAM modules.

NOTICE

- *The SAM connectors are designed only for occasional opening and closing cycles.*
- *Wrong inserted SAM modules and forcefully opening or closing will damage the SAM connectors.*

Socket	Position	SAM Number
X4	top	3
	button	1
X5	top	4
	button	2

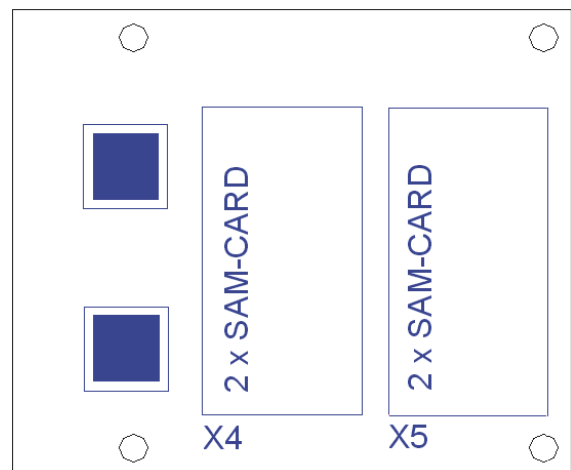

Fig. 7 Position der 4 SAM Module

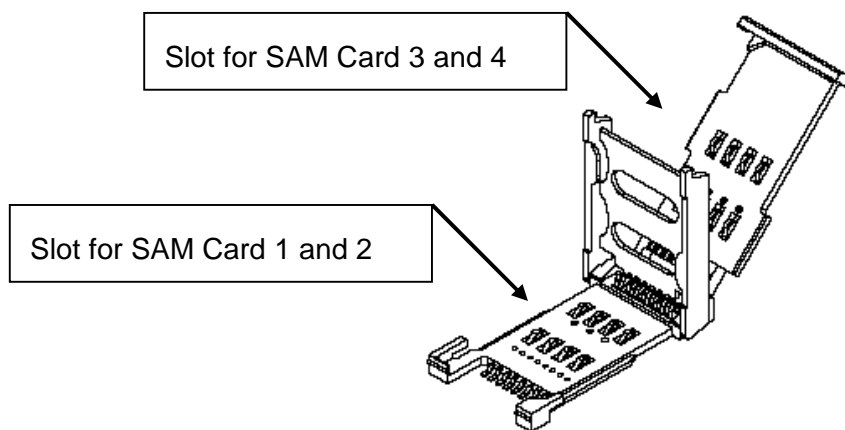
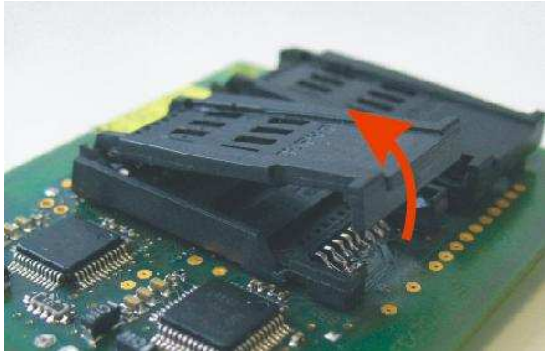
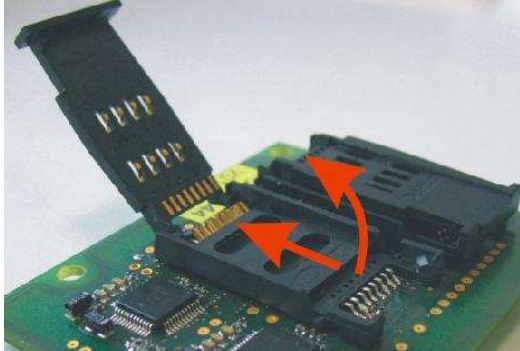
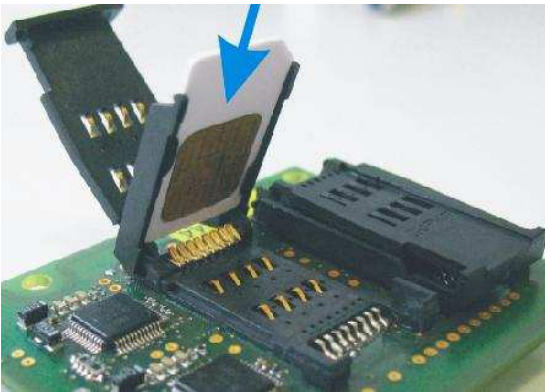
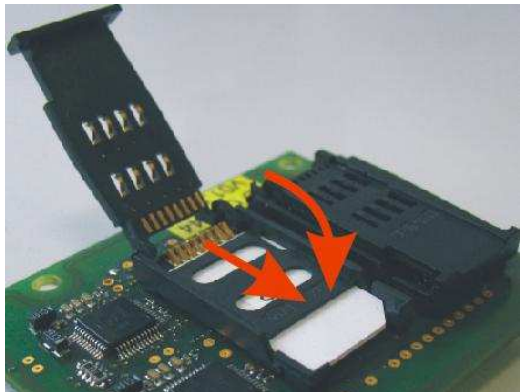
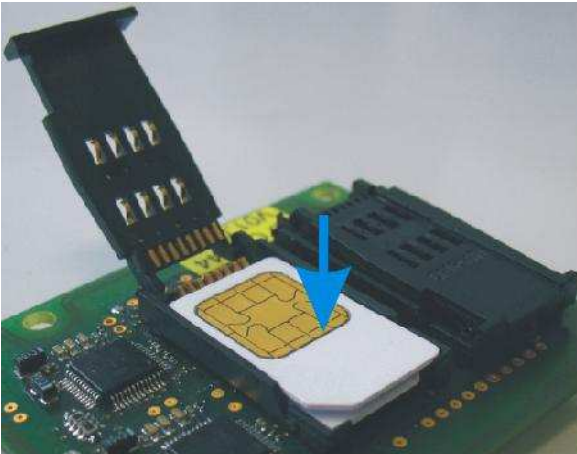
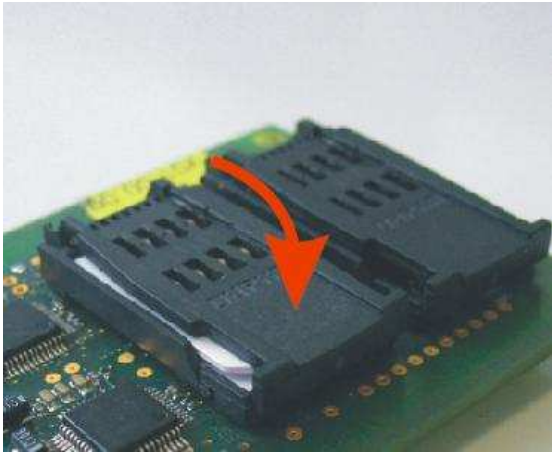

Fig. 8 SAM Modul

3.4.1. Installation of a SAM Card

The following step by step instruction shows the installation of the SAM Card 1 and 3 into the SAM connector X4. The installation of the SAM Cards 2 and 4 in the socket X5 must be done in the same way.

	
<p>1. Unlatch the top cover at the front edge.</p>	<p>2. Push the cover of lower slot backwards and open it</p>
	
<p>3. Put the SAM module 1 into the cover of the lower slot. The contact plate face down</p>	<p>4. Turn down the cover of the lower slot and push it forward till the cover is locked.</p>
	
<p>5. Place the SAM Card 3 with the contact face at the top on the cover of the lower slot.</p>	<p>6. Close the top cover with carefully pressure to snap into place.</p>

3.5. Installation notes

Be aware of the following possible environmental factors when installing an ID CPR44 into another device :

- Effects from nearby metal objects
 - ⇒ Detuning of the integrated antenna
 - ⇒ Impaired communication of the antenna's magnetic field
- EMC effects on cables
 - ⇒ Impaired communication between reader and transponder
- EMC effects from magnetic fields
 - ⇒ Impaired communication between reader and transponder

3.5.1. Metallic surroundings

When installing an ID CPR44 into another device, be sure that there are no metal surfaces or objects in the direct vicinity of the reader if possible. These can detune the antenna and thus reduce the magnetic field of the integrated antenna. This will in turn result in reduced read distances for the reader.

The distance between the reader and a metal surface should be at least 3 cm. Note that even other circuit boards may act like metal objects depending on how much copper they contain.

If a metallic surrounding cannot be avoided, stable function should at least be ensured by keeping the distance as great as possible.

The area between the antenna and transponder as well as the area on the other side of the transponder should also be kept clear of metal parts.

Since any change in the metallic environment will result in detuning of the integrated antenna and therefore to impaired function, no moving metal parts, such as metallic fans, should be allowed in the vicinity of the reader.

3.5.2. EMC effects on cables

In spite of the internal EMC filters inside the reader, high levels of noise on the supply voltage can result in impairment of the communication between the reader and transponder.

When installing an ID CPR44 into another device, be sure therefore that a clean, noise-free power supply is used.

3.5.3. EMC effects from magnetic fields

The communication principle of RFID- Technology is based on the modulation of electromagnetic fields. Alternating magnetic fields in the vicinity of the antenna can have a negative influence on the reader function.

Sources of such magnetic interference fields include coils within a primary or secondary switching power supply.

When determining the position of the reader and antenna within a device, check the device for any possible sources of interference as described above. If necessary, use shielding to suppress such interference.

4. Radio Approvals

4.1. Europe (CE)

When used according to regulation, this radio equipment conforms with the basic requirements of Article 3 and the other relevant provisions of the R&TTE Guideline 1999/EC dated March 99.



Equipment Classification according ETSI EN 300 330: Class 2

4.2. USA (FCC) and Canada (IC)

Product name:	ID CPR44
FCC ID:	PJMCPR44
IC:	6633A-CPR44
Notice for USA and Canada	<p>This device complies with Part 15 of the FCC Rules and with RSS-210 of Industry Canada.</p> <p>Operation is subject to the following two conditions.</p> <p>(1) this device may not cause harmful interference, and</p> <p>(2) this device must accept any interference received, including interference that may cause undesired operation.</p> <p>Unauthorized modifications may void the authority granted under Federal communications Commission Rules permitting the operation of this device.</p> <p>This equipment has been tested and found to comply with the limits for a Class A digital device, pursuant to Part 15 of the FCC Rules. These limits are designed to provide reasonable protection against harmful interference when the equipment is operated in a commercial environment. This equipment generates, uses, and can radiate radio frequency energy and, if not installed and used in accordance with the instruction manual, may cause harmful interference to radio communications. Operation of this equipment in a residential area is likely to cause harmful interference in which case the user will be required to correct the interference at his own expense.</p> <p>Le présent appareil est conforme aux CNR d'Industrie Canada applicables aux appareils radio exempts de licence. L'exploitation est autorisée aux deux conditions suivantes :</p> <p>(1) l'appareil ne doit pas produire de brouillage, et</p> <p>(2) l'utilisateur de l'appareil doit accepter tout brouillage radioélectrique subi, même si le brouillage est susceptible d'en compromettre le fonctionnement.</p>

Warning: Changes or modification made to this equipment not expressly approved by FEIG ELECTRONIC GmbH may void the FCC authorization to operate this equipment.

Installation with FCC / IC Approval:

FCC-/IC-NOTICE: To comply with FCC Part 15 Rules in the United States / with IC Radio Standards in Canada, the system must be professionally installed to ensure compliance with the Part 15 certification / IC certification. It is the responsibility of the operator and professional installer to ensure that only certified systems are deployed in the United States / Canada.

5. Technical Data

Weight	approx 20 g
Antenna	<ul style="list-style-type: none"> • Internal (48 mm x 58 mm)
Temperature Range	Operating -25°C to +70°C Storage -40°C to +85°C
Humidity	0 to 95 % not condensing
Power Supply	<ul style="list-style-type: none"> • 5 V DC \pm 5 % Ripple: 0...250 kHz < 10 mVpp up from 250 kHz < 0,1 mVpp
Current consumption	typ. 300 mA ¹
RF Interface	ISO14443-A & ISO14443-B (Part 4 fully supported) 106, 212, 424, 847 kbit/s
Supported Transponder (reading and writing)	mifare classic, mifare Ultralight, mifare Ultralight C, mifare DESfire, mifare PLUS, Smart MX, my-d proxim- ity, SLE44R35S, SLE55R, Jewel, SLE66CL, ST19XR34, SRI4K, SRIX4K, SRI512, SR176, RF360, etc. NFC Type 1, 2 and Type 4 in card emulation mode
Operating Frequency	13.56 MHz
RF Transmitting Power	400 mW \pm 2 dB
Host-Interface	<ul style="list-style-type: none"> • USB Full-Speed (12 Mbit/s) Self-Powered Device • RS232-TTL (4.800 to 230.400 Baud)
Digital Output	3 ($I_{out\ high\ max.}$: 5 mA / $I_{out\ low\ max.}$: 8 mA)
Connector	VCC, RS232TTL, Digital Outputs: <ul style="list-style-type: none"> • JST PH 7pin. (X1) USB: <ul style="list-style-type: none"> • JST PH 5pin. (X2)
Contact Interface (ISO7816) (only types with SAM)	4 * SAM Socked for ID000 Format (SIM-Card) 9600 to 375.000 bit/s T=0 and T=1 Protocol for 1,8 V; 3 V; 5 V Smartcards
MTBF	500.000 h

¹ Current consumption of SAMs excluded

USB Driver	<ul style="list-style-type: none">• PC/SC Driver for Windows• Native OBID® USB Driver for Windows• Windows® CE for different platforms on request
Operating Modes	Polling-Mode
EEPROM (for Parameter)	1 * 10 ⁶ write cycles
FLASH (for Firmware)	(Firmware update in Application possible)
Radio Approval	Europe EN 300 330 USA FCC 47 CFR Part 15 Canada IC RSS-Gen, RSS-210
EMC	EN 301 489
Safety and Health	EN 60950 EN 50364
Waste and Hazardous Substances	WEEE - 2002/96/EC RoHS - 2002/95/EC