

INSTALLATION

cVEND plug

Contactless Payment and Ticketing Module



Note

© Copyright 2014 by
FEIG ELECTRONIC GmbH
Lange Strasse 4
D-35781 Weilburg
Tel.: +49 6471 3109-0
<http://www.feig.de>

With the edition of this document, all previous editions become void. Indications made in this manual may be changed without previous notice.

The reproduction, distribution and utilization of this document as well as the communication of its contents to others without express authorization is prohibited. Offenders will be held liable for the payment of damages. All rights reserved in the event of the grant of a patent, utility model or design.

Composition of the information in this document has been done to the best of our knowledge. FEIG ELECTRONIC GmbH does not guarantee the correctness and completeness of the details given in this manual and may not be held liable for damages ensuing from incorrect or incomplete information. Since, despite all our efforts, errors may not be completely avoided, we are always grateful for your useful tips.

The instructions given in this manual are based on advantageous boundary conditions. FEIG ELECTRONIC GmbH does not give any guarantee promise for perfect function in cross environments and does not give any guaranty for the functionality of the complete system which incorporates the subject of this document.

FEIG ELECTRONIC call explicit attention that devices which are subject of this document are not designed with components and testing methods for a level of reliability suitable for use in or in connection with surgical implants or as critical components in any life support systems whose failure to perform can reasonably be expected to cause significant injury to a human. To avoid damage, injury, or death, the user or application designer must take reasonably prudent steps to protect against system failures.

FEIG ELECTRONIC GmbH assumes no responsibility for the use of any information contained in this document and makes no representation that they free of patent infringement. FEIG ELECTRONIC GmbH does not convey any license under its patent rights nor the rights of others.

All brand names, trademarks or logos are property of their respective owners.

Contact:

Commercial Questions: cvend@feig.de
Technical Questions: cvend-support@feig.de

Contents

| | |
|--|-----------|
| 1. Warnings - Read before start-up ! | 4 |
| 1.1. Safety Instructions | 4 |
| 1.2. Security Instructions | 4 |
| 2. Characterization | 5 |
| 3. Mechanical Integration | 7 |
| 3.1. Dimensions | 9 |
| 4. Connection | 10 |
| 4.1. Connector X1 - Ethernet Interface | 11 |
| 4.2. Connector X2 - USB Device Interface | 12 |
| 4.3. Connector X3 - RS232 V.24 (UART#1) Interface | 13 |
| 4.4. Connector X4 - RS232-LVTTL (UART#0) Interface | 14 |
| 4.5. Connector X5 – Power Supply Vcc..... | 15 |
| 4.6. Wake-Up..... | 16 |
| 4.7. Connector X6, X11, X12 - Extension Interfaces | 17 |
| 4.7.1. Connector X6 - RGB Display (cVEND plug flex only) | 17 |
| 4.7.2. Connector X11 - SAM and SD Interface..... | 18 |
| 4.7.3. Connector X12 - Auxiliary Interfaces | 18 |
| 5. Technical Data | 19 |
| 5.1. Standard Compliance..... | 20 |
| 5.2. Radio Approvals | 20 |
| 5.2.1. Europe (CE)..... | 20 |
| 5.2.2. USA (FCC) and Canada (IC)..... | 21 |
| 6. cVEND plug SAM Extension - Option | 23 |

1. Warnings - Read before start-up !

1.1. Safety Instructions

- The device may only be used for the intended purpose designed for by the manufacturer.
- The operation manual should be conveniently kept available at all times for each user.
- Unauthorized changes and the use of spare parts and additional devices which have not been sold or recommended by the manufacturer may cause fire, electric shocks or injuries. Such unauthorized measures shall exclude any liability by the manufacturer.
- The liability-prescriptions of the manufacturer in the issue valid at the time of purchase are valid for the device. The manufacturer shall not be held legally responsible for inaccuracies, errors, or omissions in the manual or automatically set parameters for a device or for an incorrect application of a device.
- Repairs may only be executed by the manufacturer.
- Installation, operation, and maintenance procedures should only be carried out by qualified personnel.
- Use of the device and its installation must be in accordance with national legal requirements and local electrical codes .
- When working on devices the valid safety regulations must be observed.
- Special advice for carriers of cardiac pacemakers:
Although this device doesn't exceed the valid limits for electromagnetic fields you should keep a minimum distance of 25 cm between the device and your cardiac pacemaker and not stay in an immediate proximity of the device respective the antenna for some time.

1.2. Security Instructions

- **DO NOT DISASSEMBLE ANY PART!** The device contains a battery-powered security circuited. The security circuit will be triggered if security relevant parts are disassembled. In such cases the device stops regular operation and can be reactivated only by the manufacturer in a certified secure environment.

2. Characterization

The cVEND plug is a secure contactless module for contactless credit cards (open-loop) and public transport tickets (closed-loop). It fulfills the newest functional and security related payment card industry standards.

cVEND plug is designed for flush integration into non conducting housings. It is EMVCo contactless certified, if installed according the guidelines described in this manual.

cVEND plug is available in two versions:

→ cVEND plug flex

The cVEND plug flex is a flexible secure platform to develop a payment and ticketing solution. Due to the variety of interfaces and the open SDK cVEND plug flex can be the core element for a terminal. direct connection of color or monochrome displays, touch screens, external scanners or other peripheral components are possible.

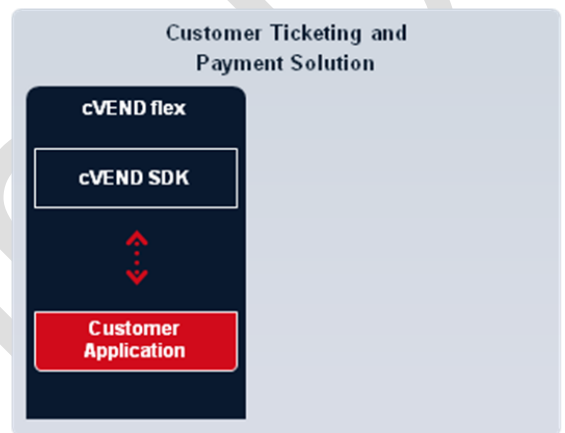

→ cVEND plug reader

The cVEND plug reader is a secure contactless reader for payment and ticketing applications which includes an EMVCo contactless Level 2 kernel for credit card processing. The cVEND plug reader offers an easy to use secure protocol and can be used in payment mode as well as in transparent card reader mode which makes it suitable for payment and ticketing applications.

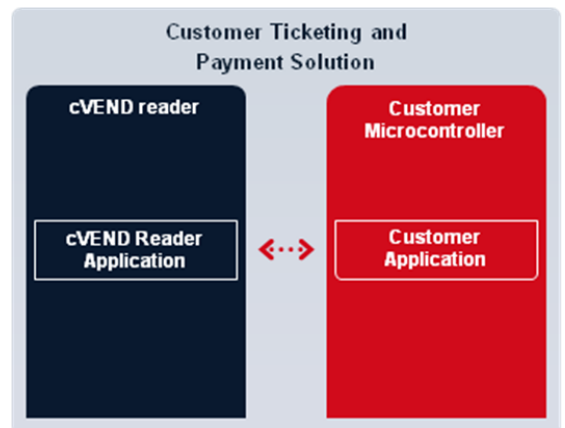

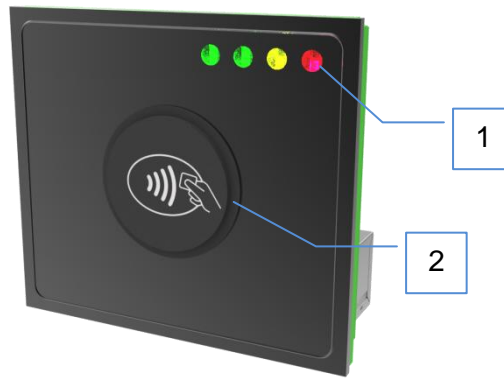

Fig. 1: cVEND plug front view - not installed

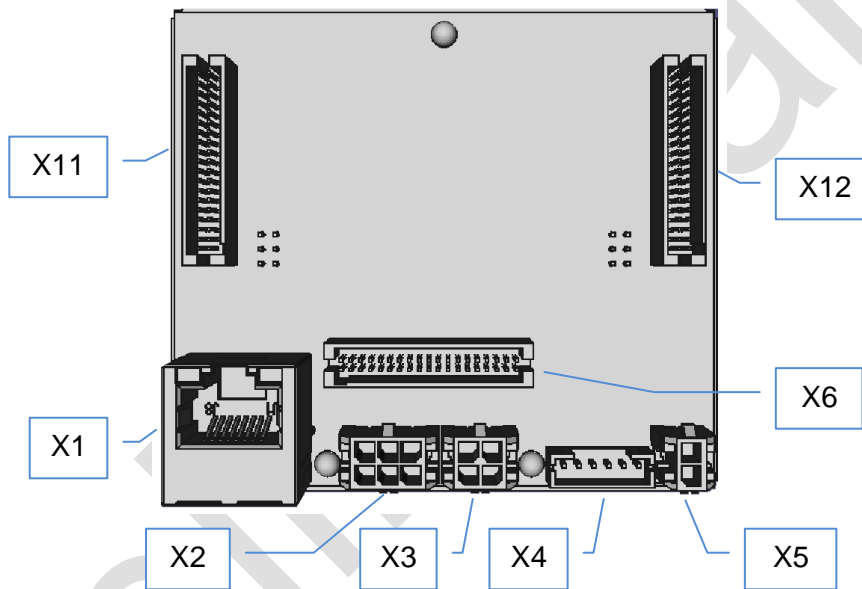

Fig. 2: cVEND plug rear view - not installed

Table 1: Interfaces and connectors

| Label | Description |
|------------|---|
| 1 | LEDs (4 x green, 1 x yellow, 1 x red) |
| 2 | From outside visible, illuminated plastic dome "Plug" |
| X1 | Ethernet Interface (10 / 100 Base-T network port) |
| X2 | USB Device Interface |
| X3 | RS232 V.24 (UART#1) Interface |
| X4 | RS232-LVTTL (UART#0) Interface |
| X5 | Power Supply 5V DC |
| X6 | Connector for RGB Display (cVEND plug flex only) |
| X11 | Connector for SAM / SD-Card Extension Board |
| X12 | Connector for Auxiliary Interfaces |

3. Mechanical Integration

For flush integration into non conducting housings one round opening with a diameter of 28,5 mm is necessary to show the back-lit contactless symbol. cVEND plug is installed from inside the housing. cVEND plug is designed for front plates with 3 mm thickness.

cVEND plug has to be installed from inside the housing. If the LEDs of cVEND plug shall be used, additional light channels are to be provided.

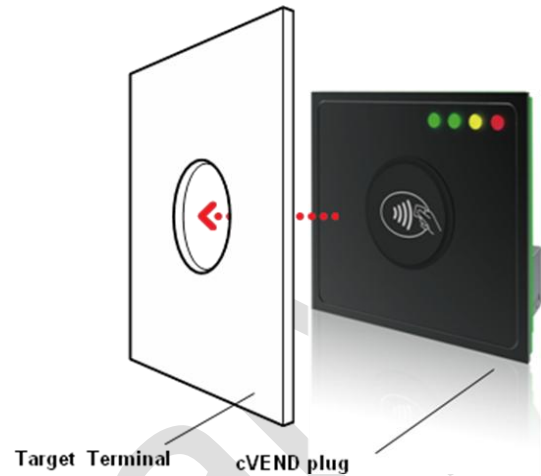

NOTICE

To comply with EMVCo regulations:

- **The contactless logo must be visible.**
- **The upper edge of the cVEND plug plastic dome and the target terminal front plate must be on the same level.**
- **Avoid any kind of conducting material surrounding the cVEND plug.**
- **Do not use conducting materials for fastening.**

The following figure shows cross-sectional view of cVEND plug plastic dome (1) flush installed into target terminal front plate (2)

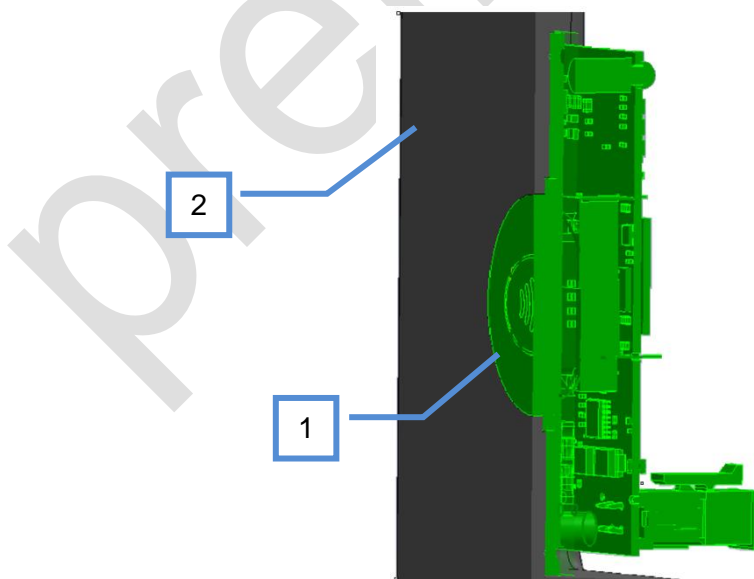

Fig. 3: cVEND plug (1) installed in front plate (2) - cross-sectional view

The cVEND plug front consists of a silicon rubber mat (1) with integrated sealing (2) and a fixed poly carbonate plastic dome (3) which shows the back-lit contactless symbol.

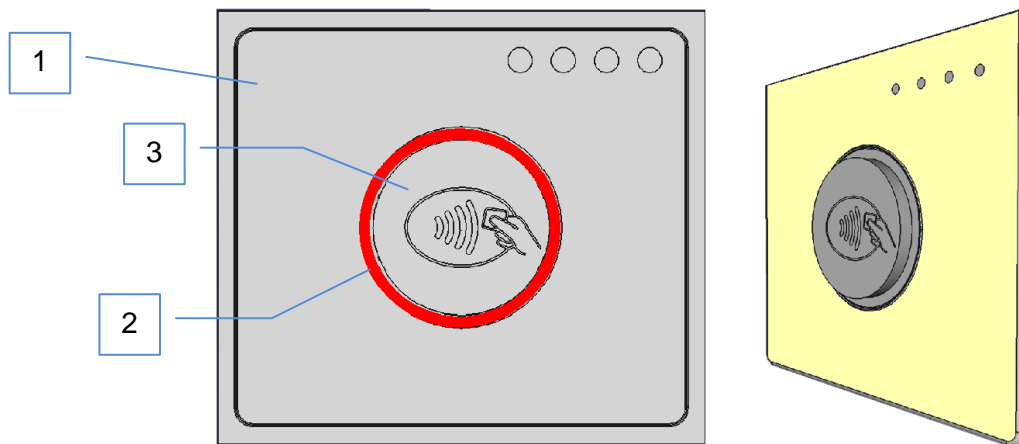

Fig. 4: Plug front with sealing (red colored)

For fastening the cVEND plug front has to be pressed tight against the housing front. Therefore a clamp range of 2,5 mm (fastening area) on all sides of the cVEND plug antenna PCB is available. The following figure shows the clamp range (red marked). The picture on the left side shows the back view, the picture on the right side is perspective view. For detailed dimension see Chapter 3.1. Dimensions. 3D STEP Data are available on request.

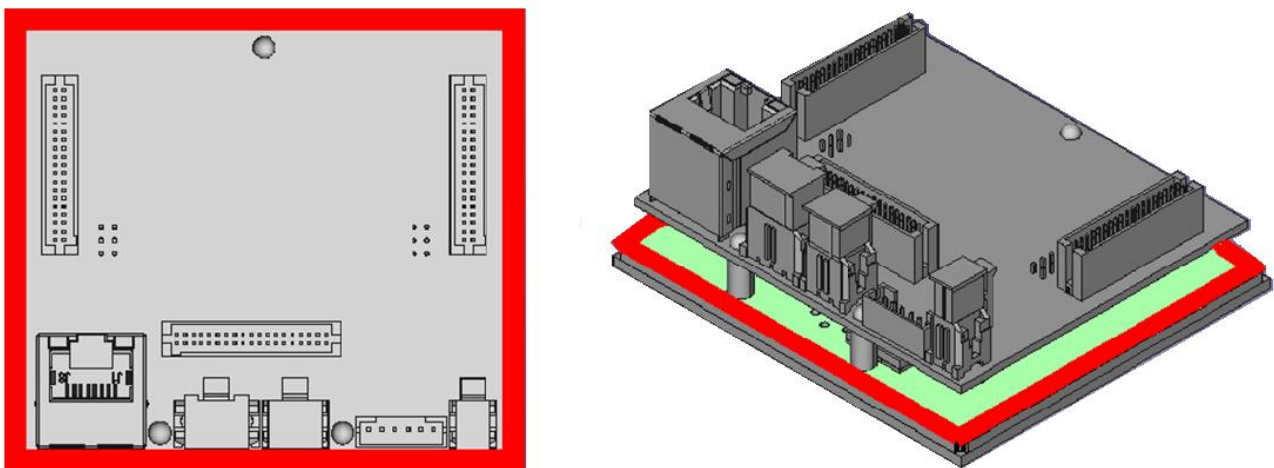

Fig. 5: cVEND plug fastening area (red marked)

3.1. Dimensions

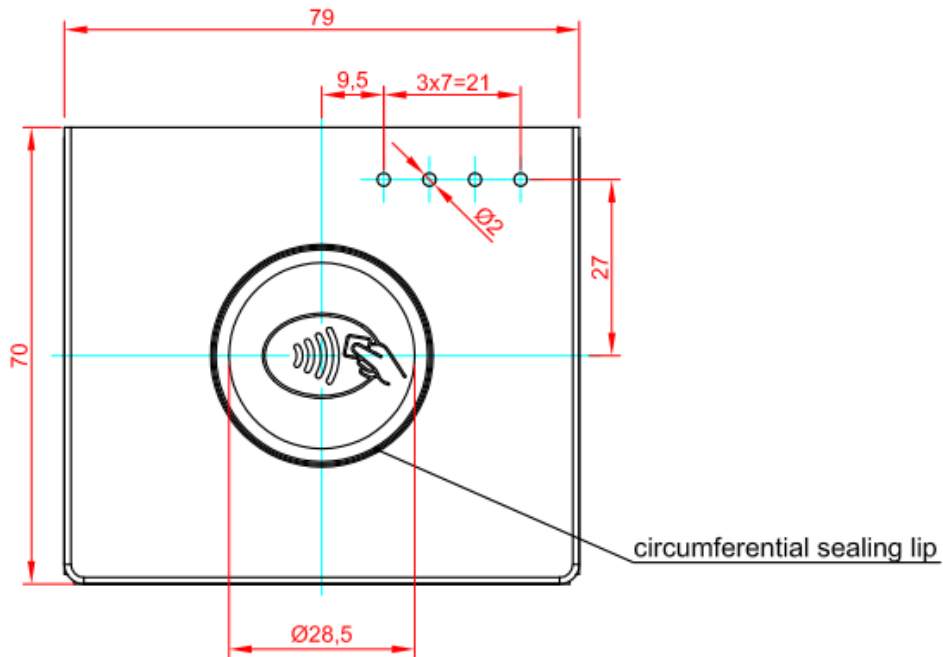

Fig. 6: cVEND plug front with LED position

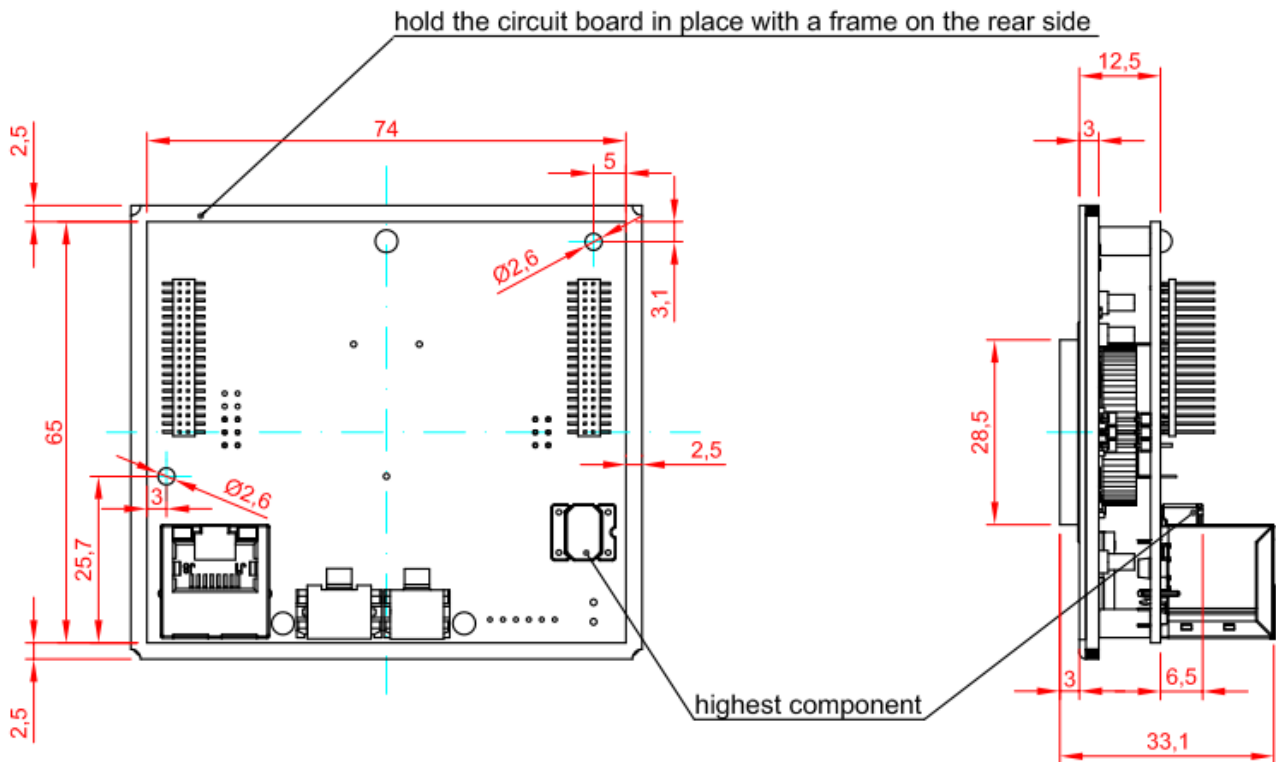

Fig. 7: cVEND plug rear and side view (without cVEND SAM Extension Board)

4. Connection

The connector I/O PINs are described from the cVEND plug view. A cVEND plug input must be connected to one output or vice versa.

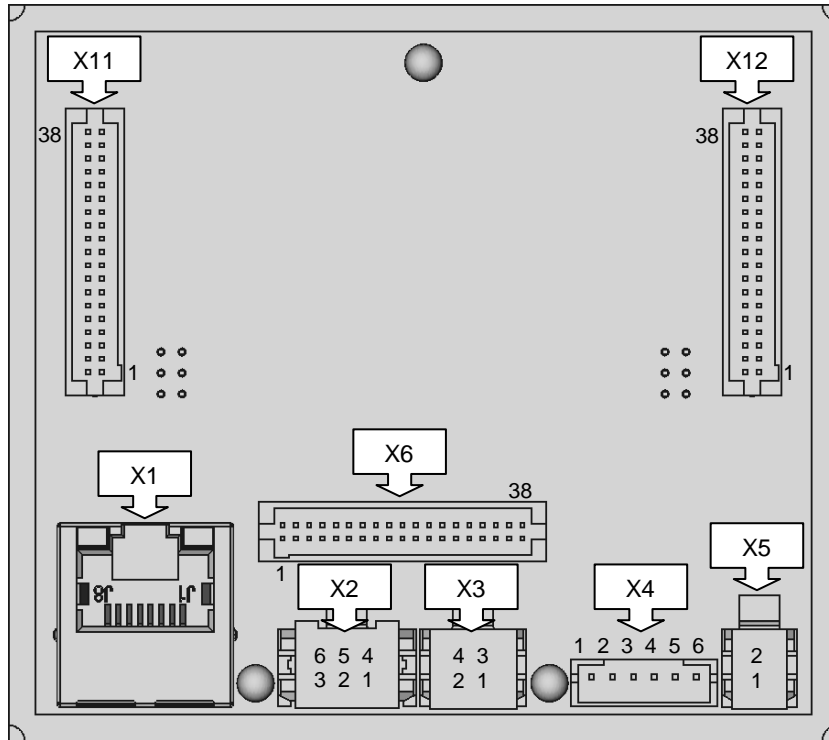

Fig. 8: cVEND plug - connector location

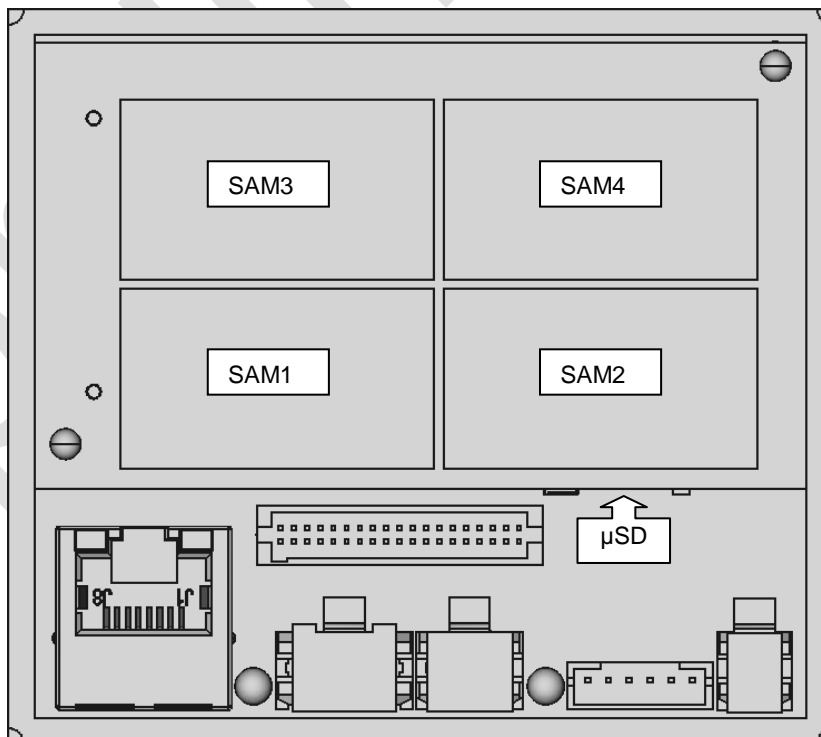

Fig. 9: cVEND plug with optional SAM Extension Board

4.1. Connector X1 - Ethernet Interface

cVEND has an integrated 10 / 100 Base-T network port at RJ45 connector X1, with automatic polarity correction during auto-negotiation and 10 Base-T signal reception.

CAT 5 cables are recommended to ensure a reliable operation at 10 Mbps or 100 Mbps.

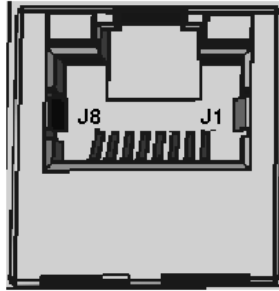

Fig. 10: Ethernet Interface at connector X1

Required Connector: RJ45

Table 2: Pin Assignment Ethernet Connector

| PIN | Label |
|-----|-------|
| 1 | TX+ |
| 2 | TX- |
| 3 | RX+ |
| 4 | VETH+ |
| 5 | VETH+ |
| 6 | RX- |
| 7 | VETH- |
| 8 | VETH- |

4.2. Connector X2 - USB Device Interface

At connector X2 a USB-Device interface is provided where USB-Host can be connected. cVEND is designed as a self powered device. powering over USB interface is not possible.

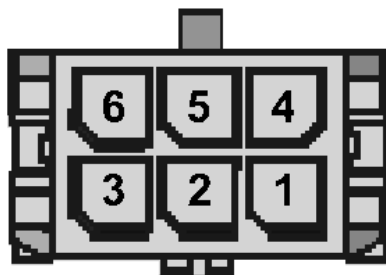

Fig. 11: USB Interface at connector X2

Required Connector:

The fitting complement for this connector consists of a 6-pole plug Type Molex Micro Fit and the appending Crimp contact.

Manufacturer ordering code:

Molex 43025-0600

Plug, 6-pole, grid dimension 3.0 mm, Dual Row, Molex Micro Fit housing

Molex 43030-0001

Crimp contact, Female, grid dimension 3.0 mm, AWG#20-24, Molex Micro Fit

Table 3: Pin Assignment USB Connector

| PIN | Label | Direction |
|-----|---------|-----------|
| 1 | DEV-Vcc | I |
| 2 | DEV-D- | I/O |
| 3 | DEV-D+ | I/O |
| 4 | N.C. | - |
| 5 | GND | - |
| 6 | Shield | - |

NOTE:

The USB interface is specified for max. 5 m (16,4 ft) cable length.

4.3. Connector X3 - RS232 V.24 (UART#1) Interface

X3 is the connector for a RS232 interface on V.24 level.

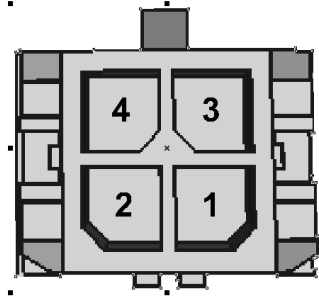

Fig. 12: RS232 V.24 (UART#1) Interface at connector X3

Required Connector:

The fitting complement for this connector consists of a 4-pole plug Type Molex Micro Fit and the appending Crimp contact.

Manufacturer ordering code

Molex 43025-0400

Plug, 4-pole, grid dimension 3.0 mm, Dual Row, Molex Micro Fit housing

Molex 43030-0001

Crimp contact, Female, grid dimension 3.0 mm, AWG#20-24, Molex Micro Fit

Table 4: Pin Assignment RS232 V.24 Interface

| PIN | Label | Direction | Remark |
|-----|------------|-----------|------------------|
| 1 | Device TXD | O | |
| 2 | Device RXD | I | |
| 3 | Wake-UP | I/O | see 4.6. Wake-Up |
| 4 | GND | - | |

4.4. Connector X4 - RS232-LVTTL (UART#0) Interface

At connector X4 a RS232 interface on LVTTL 3.3V level is provided. This interface offers also hardware handshake.

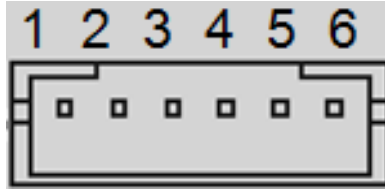

Fig. 13: RS232-LVTTL Interface at connector X4

Required Connector:

The fitting complement for this connector consists of a 6 -pole plug Type JST PH and the appending Crimp contact.

Manufacturer ordering code:

JST PHR-6 - housing, 6-pole, grid dimension 2.0 mm, Single Row
 JST SPH-002T-P0.5 or SPH-004T-P0.5 Crimp contact

Table 5: Pin Assignment RS232 LVTTL Interface

| PIN | Label | Direction | |
|-----|------------|-----------|------------------|
| 1 | Device RTS | O | |
| 2 | GND | - | |
| 3 | Device RXD | I | |
| 4 | Device TXD | O | |
| 5 | Device CTS | I | |
| 6 | Wake-Up | I/O | see 4.6. Wake-Up |

NOTE:

The length of the cable to the RS232-LVTTL interface should be kept as short as possible, and must in any case not exceed 3 m.

4.5. Connector X5 – Power Supply Vcc

cVEND must be supplied by a regulated power supply of 5 V DC only. If switching power supplies are used be sure that there is adequate filtering. Noise from the power supply can result in a reduction of the read/write range of the module. The cable length from the power supply should be as short as possible, and should in any case not exceed 3 m.

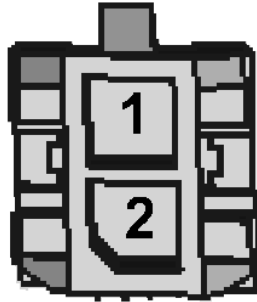

Fig. 14: Power Supply at connector X5

Required Connector:

The fitting complement for this connector consists of a 2-pole plug Type Molex Micro Fit and the appending Crimp contact.

Manufacturer ordering code

Molex 43025-0200

Plug, 2-pole, grid dimension 3.0 mm, Dual Row, Molex Micro Fit housing

Molex 43030-0001

Crimp contact, Female, grid dimension 3.0 mm, AWG#20-24, Molex Micro Fit

Table 6: Pin Assignment Power Supply

| PIN | Label | Direction | Remark |
|-----|-------|-----------|----------|
| 1 | Vcc | I | 5,0 V/DC |
| 2 | GND | - | |

NOTE:

The reader has to be supplied by a limited power supply (e.g. NEC Class 2/LPS power supply) according IEC EN 60950-1 chapter 2.5, only.

Reversing the polarity of the supply voltage may destroy the device.

Supply voltages outside the specifications may destroy the device.

4.6. Wake-Up

cVEND offers a standby mode which can be configured via software commands. If standby is activated the bidirectional Wakeup I/O is used for signaling a wakeup event by the cVEND and can be used by the host to activate the cVEND.

Wakeup by host:

The host controller can awake the cVEND by pulling down the Wakeup line.

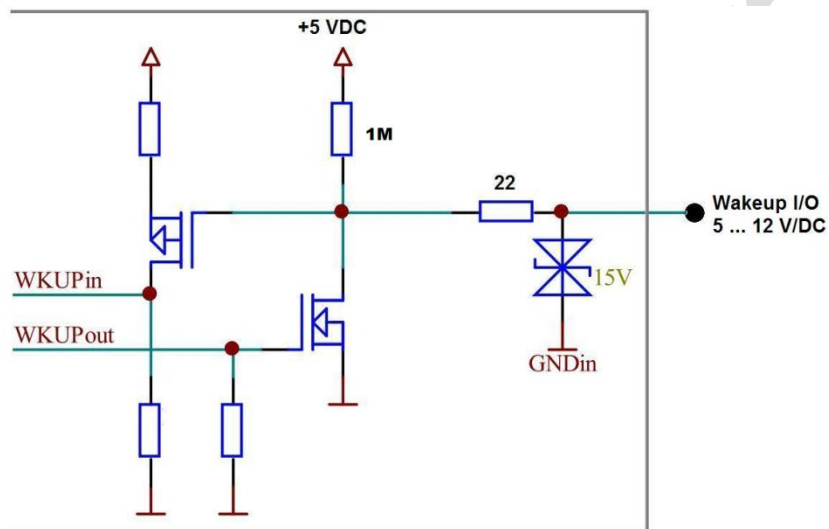

Fig. 15: cVEND internal Wake-up circuit

NOTE:

If the standby - wakeup option is used in connection with the USB interface the USB connection will be interrupted while standby mode.

4.7. Connector X6, X11, X12 - Extension Interfaces

Via X11 and X12 the optional extension board, which offers 4 sockets for SAM cards and one socket for a SD memory card, can be connected.

Alternatively X11 and X12 can be used to connect custom specific electronics. therefore this connectors are offering signals to connect external smart card drivers, SD memory cards, digital I/Os and I²C, SPI and USB Host interfaces. Further technical details, implementation recommendations and schematics are available on request.

NOTICE:

Some of the Extension Interfaces may need a dedicated software driver which may not provided by the standard cVEND SDK.

4.7.1. Connector X6 - RGB Display (cVEND plug flex only)

X6 is intended for connecting an external custom specific RGB Display. technical details are available on request.

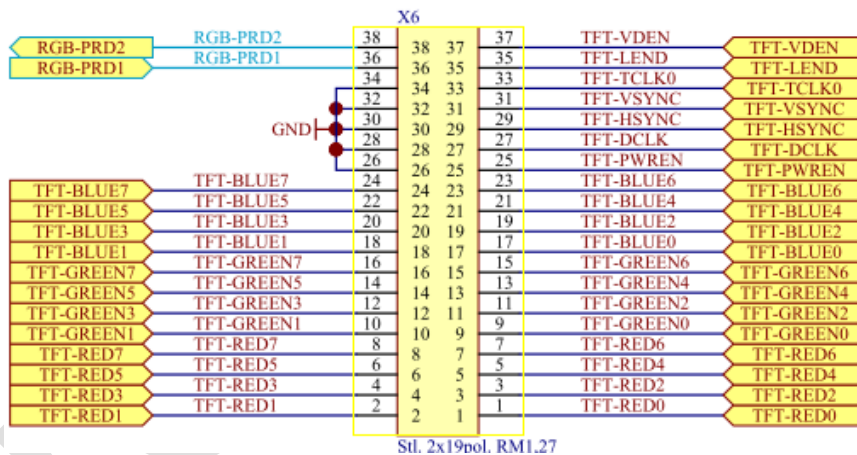

Fig. 16: cVEND plug X6 - PIN assignment.

4.7.2. Connector X11 - SAM and SD Interface

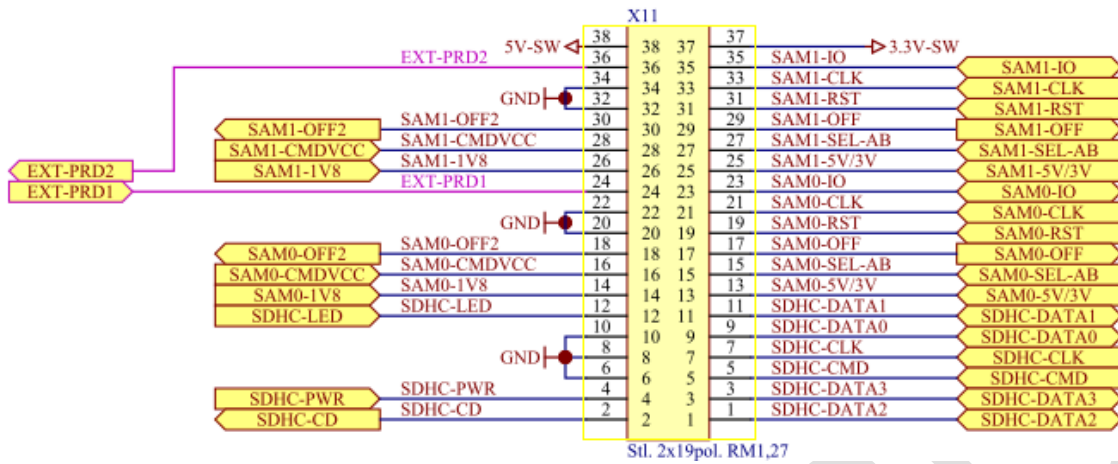

Fig. 17: cVEND plug X11 - PIN assignment.

4.7.3. Connector X12 - Auxiliary Interfaces

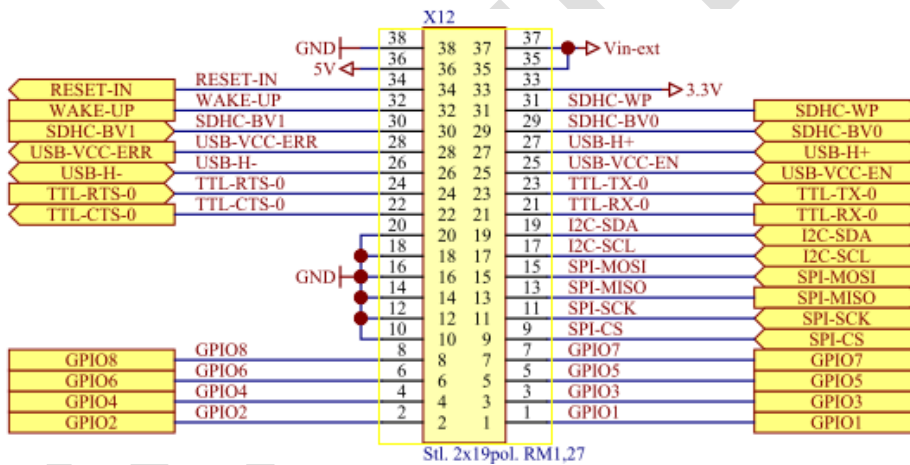

Fig. 18: cVEND plug X12 - PIN assignment.

5. Technical Data

| | | flex | reader |
|--|--|------|--------|
| Housing | <ul style="list-style-type: none"> plug front with contactless symbol (visible dome: PC; plane: Silicon) | ✓ | ✓ |
| Dimensions over all (W x H x D) | <ul style="list-style-type: none"> 79 x 70 x 37 mm | ✓ | ✓ |
| Dimensions visible | <ul style="list-style-type: none"> ∅ 28.5 mm | | |
| Wight | <ul style="list-style-type: none"> 85 g | ✓ | ✓ |
| Temperature Range | Operating <ul style="list-style-type: none"> -25 °C to +70 °C ambient temperature Storage <ul style="list-style-type: none"> -25 °C to +80 °C | ✓ | ✓ |
| Humidity | <ul style="list-style-type: none"> 95 % max, (no condensing) | ✓ | |
| Power Supply | <ul style="list-style-type: none"> 5,0 to 5,5 V DC (Ripple < 80 mVpp) | ✓ | ✓ |
| Power Consumption Operation | <ul style="list-style-type: none"> typ. < 1 A, peripherals excluded | ✓ | ✓ |
| Standby Mode | <ul style="list-style-type: none"> < 20 mA, Full operation after wake-up ≤ 1 Sec Wakeup by Card and digital input | ✓ | ✓ |
| RFID Interface | <ul style="list-style-type: none"> Integrated Antenna 13,56 MHz ISO/IEC 14443-A / -B (NFC reader/writer mode) in EMVCo contactless mode JIS X 6319-4 (Sony Felica) transparent communication channel NFC IP1 (P2P) and NFC card emulation mode hardware enabled | ✓ | ✓ |
| Supported Transponder | <ul style="list-style-type: none"> ISO/IEC 14443-4 compliant smart cards, NFC Type 1, 2 and 4 in card emulation mode, mifare classic, mifare ultralight and further technologies on request | ✓ | ✓ |
| Peripheral Interfaces | <ul style="list-style-type: none"> Ethernet - IEEE 802.3/Ethernet, 10/100 Mbps RS232 (V.24) RS232-LVTTL, incl. CTS, RTS signals USB 2.0 Host hardware enabled USB 2.0 Device SPI hardware enabled I2C 100/400 kHz hardware enabled 24-Bit RGB-bus interface for external TFT displays hardware enabled | ✓ | ✓ |
| User Interface | <ul style="list-style-type: none"> 6 LED (4 green, 1 red, 1 yellow), Buzzer, illuminated Payment Logo | ✓ | ✓ |
| CPU and Security | <ul style="list-style-type: none"> ARM 9 CPU (384 MHz) – Tamper Protected and Side Channel Attack Resistant with Real Time Memory Encryption Cryptographic Hardware Acceleration supports SHA, DES, AES True Random Number Generator RAM MByte 128 / FLASH MByte 256 Real Time Clock – Battery backed | ✓ | ✓ |
| Battery | <ul style="list-style-type: none"> 3V Lithium Battery, 540 mAh, Lifetime 10 year at 25 °C¹ | ✓ | ✓ |

¹ Battery is needed for security function and RTC. Higher temperature will reduced lifetime!

5.1. Standard Compliance

| | | |
|---------------------------------------|--------|--|
| Radio Approval | Europe | • EN 300 330 |
| | USA | • FCC 47 CFR Part 15 |
| | Canada | • IC RSS-Gen, RSS-210 |
| EMC | | • EN 301 489 |
| Safety and Health | | • EN 60950 |
| | | • EN 50364 |
| Hazardous Substances | | • RoHS - 2011/65/EC |
| Electrostatic Discharge | | • ISO 10605, Category 3 |
| Protection Class (Front Side) | | • IP65 (if accurate installed) |
| Impact protection Class | | • IEC 62262, IK10 (installed in equivalent robust housing) |
| Shock and Vibration | | • IEC 60721-3-5, Class 5M3 |
| Payment | | • EMVCo 2.4 Contactless Level 1 |
| | | • PCI PTS 4.x, SRED incl. Open Protocol |
| Contactless Payment Kernel (Optional) | | • MasterCard PayPass |
| | | • VISA Paywave |
| | | • American Express Expresspay |
| | | • Discover |

5.2. Radio Approvals

5.2.1. Europe (CE)

When properly used this radio equipment conforms to the essential requirements of Article 3 and the other relevant provisions of the R&TTE Directive 1999/5/EC of March 99.



Performance Classification according to ETSI EN 301 489: Class 2

5.2.2. USA (FCC) and Canada (IC)

| | |
|--------------------------------------|---|
| Product name: | cVEND plug |
| FCC ID: IC: | PJMcVEND 6633A-cVEND |
| Notice for USA and Canada | <p>This device complies with Part 15 of the FCC Rules and with RSS-210 of Industry Canada.</p> <p>Operation is subject to the following two conditions.</p> <p>(1) this device may not cause harmful interference, and</p> <p>(2) this device must accept any interference received, including interference that may cause undesired operation.</p> <p>Unauthorized modifications may void the authority granted under Federal communications Commission Rules permitting the operation of this device.</p> <p>This equipment has been tested and found to comply with the limits for a Class A digital device, pursuant to Part 15 of the FCC Rules. These limits are designed to provide reasonable protection against harmful interference when the equipment is operated in a commercial environment. This equipment generates, uses, and can radiate radio frequency energy and, if not installed and used in accordance with the instruction manual, may cause harmful interference to radio communications. Operation of this equipment in a residential area is likely to cause harmful interference in which case the user will be required to correct the interference at his own expense.</p> <p>Le présent appareil est conforme aux CNR d'Industrie Canada applicables aux appareils radio exempts de licence. L'exploitation est autorisée aux deux conditions suivantes :</p> <p>(1) l'appareil ne doit pas produire de brouillage, et</p> <p>(2) l'utilisateur de l'appareil doit accepter tout brouillage radioélectrique subi, même si le brouillage est susceptible d'en compromettre le fonctionnement.</p> |

Warning: Changes or modification made to this equipment not expressly approved by FEIG ELECTRONIC GmbH may void the FCC authorization to operate this equipment.

Installation with FCC / IC Approval:

FCC-/IC-NOTICE: To comply with FCC Part 15 Rules in the United States / with IC Radio Standards in Canada, the system must be professionally installed to ensure compliance with the Part 15 certification / IC certification. It is the responsibility of the operator and professional installer to ensure that only certified systems are deployed in the United States / Canada.

preliminary

6. cVEND plug SAM Extension - Option

The optional SAM Extension board offers 4 sockets for ID000 Format smart cards and one SDHC memory card socket. It can be connected to cVEND plug via connector X11 and X12.

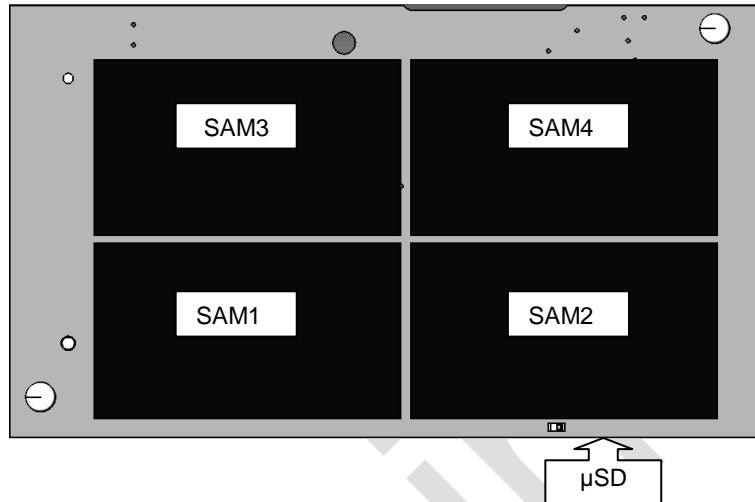

Fig. 19: cVEND plug SAM Extension - top view

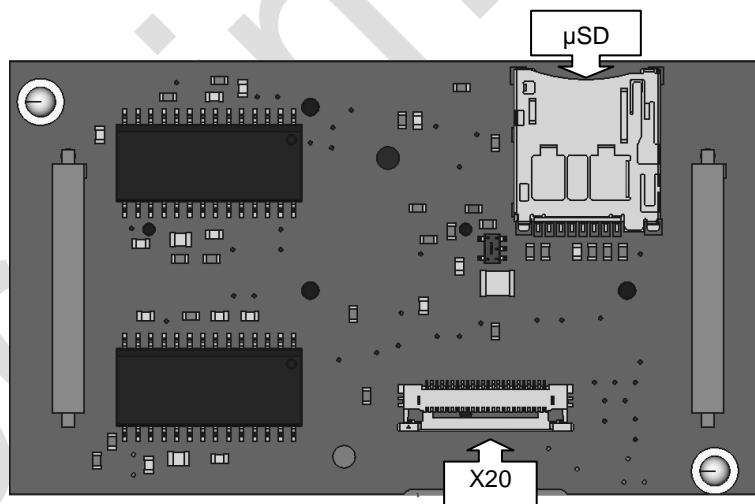

Fig. 20: cVEND plug SAM Extension - bottom view

X20: Auxiliary Interfaces

Via the 20 pol. FFC/FCP, RM 0,6 connector X20 the SPI, RS232-LVTTL, USB-Host and I²C interfaces as well as digital GPIOs are provided.

NOTICE:

Some interfaces may need a dedicated software driver which may not provided by the standard cVEND SDK.

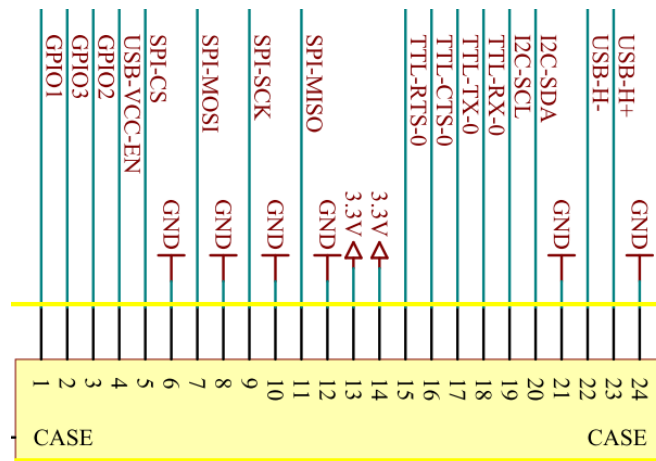

Fig. 21: cVEND plug SAM Extension - X20 Pin assignment

| | |
|--------------------------------|---|
| Removal Memory | microSD Socket SD Host Controller Version 2.0 for SD/SDHC class 10 memory card |
| SAM Interface - ISO7816 | 4 x SAM Sockets for ID000 Format (SIM-Card) T=0 and T=1 Protocol support of power class A, B, C |