

INSTALLATION MANUAL

ID ISC.MR102

For all variants



Note

© Copyright 2022 by

FEIG ELECTRONIC GmbH
Industriestraße 1a
D-35781 Weilburg (Germany)
Tel.: +49 6471 3109-0
[https://www.feig.de/en/
identification-support@feig.de](https://www.feig.de/en/identification-support@feig.de)

With the edition of this document, all previous editions become void. Indications made in this manual may be changed without previous notice.

Copying of this document and giving it to others and the use or communication of the contents thereof are forbidden without express authority. Offenders are liable to the payment of damages. All rights are reserved in the event of the grant of a patent or the registration of a utility model or design.

Composition of the information in this document has been done to the best of our knowledge. FEIG ELECTRONIC GmbH does not guarantee the correctness and completeness of the details given in this manual and may not be held liable for damages ensuing from incorrect or incomplete information. Since, despite all our efforts, errors may not be completely avoided, we are always grateful for your useful tips.

The instructions given in this manual are based on advantageous boundary conditions. FEIG ELECTRONIC GmbH does not give any guarantee promise for perfect function in cross environments and does not give any guarantee for the functionality of the complete system which incorporates the subject of this document.

FEIG ELECTRONIC GmbH calls explicit attention that devices which are subject of this document are not designed with components and testing methods for a level of reliability suitable for use in or in connection with surgical implants or as critical components in any life support systems whose failure to perform can reasonably be expected to cause significant injury to human health. To avoid damage, injury or death the user or application designer must take reasonably prudent steps to protect against system failures.

FEIG ELECTRONIC GmbH assumes no responsibility for the use of any information contained in this document and makes no representation that they are free of patent infringement. FEIG ELECTRONIC GmbH does not convey any license under its patent rights nor the rights of others.

Content

1	Safety Instructions	5
2	Performance Features of the readers	6
	Available Reader types.....	6
	Optional accessories.....	6
3	Assembly and Wiring	7
	Housing versions.....	7
	3.1.1 Dimensions	7
3.2	Module version	8
	3.2.1 Dimensions	8
4	Connections	9
4.1	Antenna terminal ANT 1	9
	4.1.1 DC Voltage supply on antenna connector ANT1	10
4.2	Power supply	10
	4.2.1 Power supply via X1	10
	4.2.2 Power supply via PoE (Power over Ethernet) on X4 (ID ISC.MR102-PoE).....	11
4.3	Power supply and interface connection on X2 (ID ISC.MR102-A)	13
	4.3.1 RS232 Interface (ID ISC.MR102-A).....	14
4.4	Ethernet-Interface on X2 (10/100Tbase)	15
4.5	USB – Interface X3 (Host communication)	15
5	Control and display elements LED	16
5.1	LED	16
6	Radio Approvals	17
6.1	Declaration of Conformity (CE), (UKCA)	17
6.2	USA (FCC) and Canada (IC)	17
6.3	UL Approval - USA and Canada	18
7	Technical Data	19

8	Annex	21
8.1	Accessories	21
8.1.1	Wall mounting kit ID ISC.MS.MR/PR-A	22
8.1.2	Serial data cable ID CAB.RS-A	23
8.1.3	Antenna.....	24

1 Safety Instructions

- ▶ The device may only be used for the intended purpose designed by for the manufacturer.
- ▶ The operation manual should be conveniently kept available at all times for each user.
- ▶ Unauthorized changes and the use of spare parts and additional devices which have not been sold or recommended by the manufacturer may cause fire, electric shocks or injuries. Such unauthorized measures shall exclude any liability by the manufacturer.
- ▶ The liability-prescriptions of the manufacturer in the issue valid at the time of purchase are valid for the device. The manufacturer shall not be held legally responsible for inaccuracies, errors, or omissions in the manual or automatically set parameters for a device or for an incorrect application of a device.
- ▶ Repairs may only be executed by the manufacturer.
- ▶ Installation, operation, and maintenance procedures should only be carried out by qualified personnel.
- ▶ Use of the device and its installation must be in accordance with national legal requirements and local electrical codes.
- ▶ When working on devices the valid safety regulations must be observed.
- ▶ Before touching the device, the power supply must always be interrupted. Make sure that the device is without voltage by measuring. The fading of an operation control (LED) is no indicator for an interrupted power supply or the device being out of voltage!
- ▶ Special advice for wearers of cardiac pacemakers:
Although this device doesn't exceed the valid limits for electromagnetic fields you should keep a minimum distance of 25 cm between the device and your cardiac pacemaker and not stay in the immediate proximity of the device's antenna for any length of time.

2 Performance Features of the readers

The Reader ID ISC.MR102 is designed for reading passive data carriers, so-called „Smart Labels“ at an operating frequency of 13.56 MHz.

The ID ISC.MR102 is suitable for all applications in which moderate reading distances are required. Also required is an external antenna connected to the Reader.

An anticollision function enables simultaneous reading of up to 100 * ISO15693 or ISO18000-3M3 transponders per second.

The Reader electronics is contained in a plastic housing having an IP30 enclosure rating.

Available Reader types

The following reader types are currently available:

Reader type	Description
ID ISC.MR102-A	Housing version with asynchronous RS232 interface
ID ISC.MRM102-A	Module version with asynchronous RS232 interface
ID ISC.MR102-PoE	Housing version with LAN interface and Power over Ethernet
ID ISC.MR102-USB	Housing version with USB-Interface
ID ISC.MRM102-USB	Module version with USB-Interface

Table 1: Reader types

Optional accessories

Optional [Accessories](#) are listed in the attachment.

3 Assembly and Wiring

Housing versions

The Reader is designed for an office environment. It can be wall-mounted, in this case the wall-mount kit should be ordered separately.

See appendix [Wall mounting kit ID ISC.MS.MR/PR-A](#)

Notes:

- **The distance between two readers of the same type should not fall below 4m.**
- **Before any installation the intended position of the reader should be tested for its suitability.**

3.1.1 Dimensions

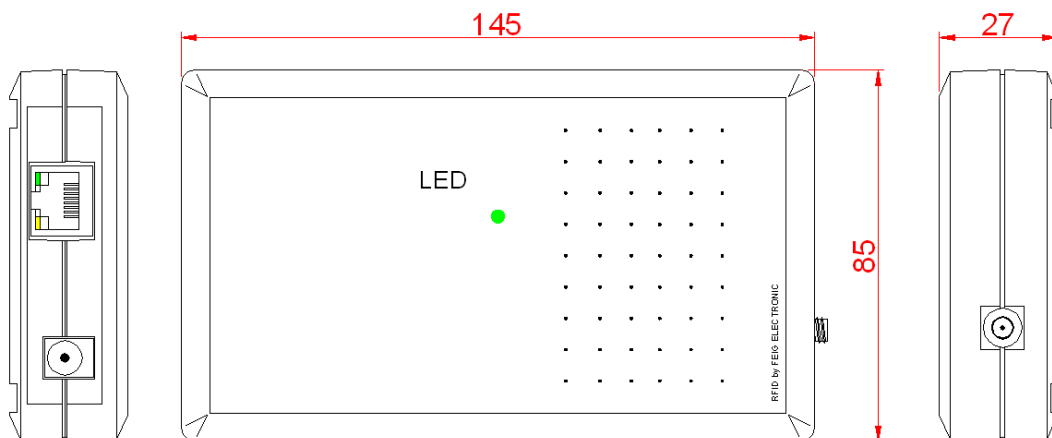

Figure 1: Dimensions of the housing version (all dimensions are in mm)

3.2 Module version

This reader version has been designed for mounting in other equipment.

Notes:

- *The distance between two readers of the same type should not fall below 4m.*
- *Before any installation the intended position of the reader should be tested for it's suit-ability.*

3.2.1 Dimensions

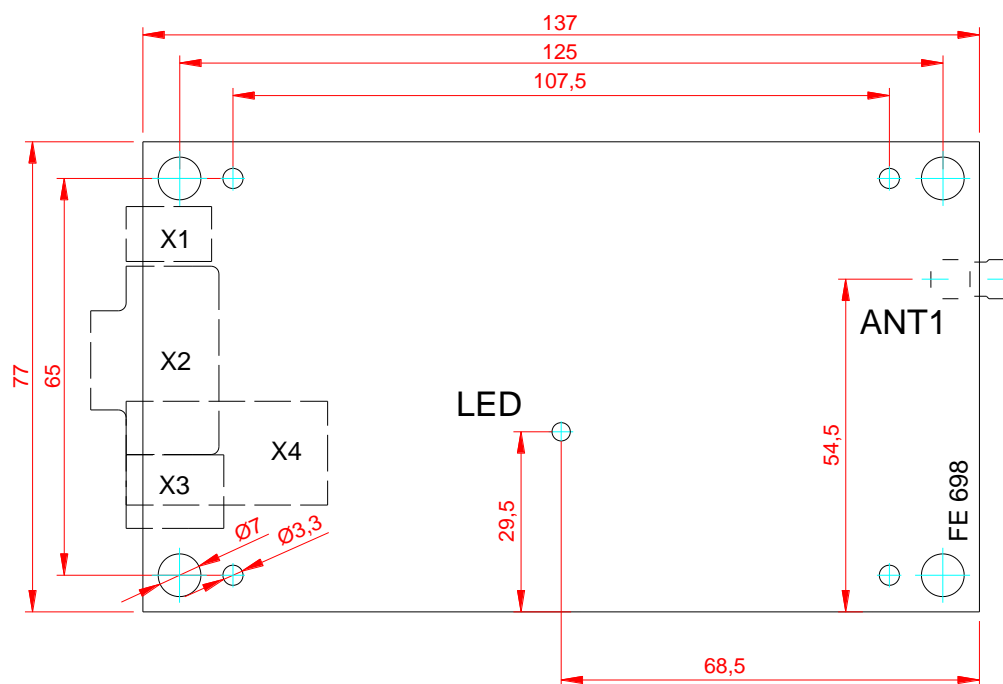

Figure 2: Dimensions of the module version (all dimensions in mm)

4 Connections

Depending on the reader variant different connectors are available. [Figure 3: Connection overview](#) displays the arrangement and the [Table 2: Connectors](#) shows which connector can be used for the different interface cable.

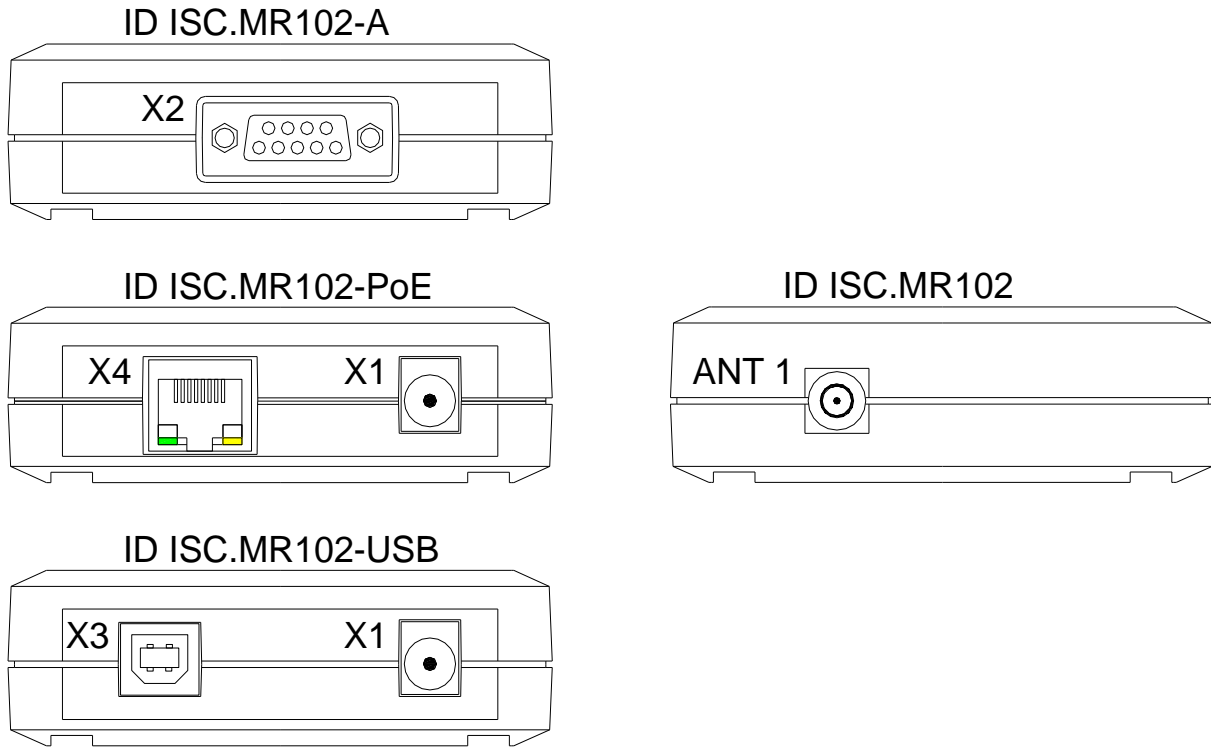

Figure 3: Connection overview

Connector	Description
ANT 1	Antenna terminal ANT 1 (Impedance 50Ohm)
X1	Power supply 12 - 24VDC
X2	RS232 Interface
X3	USB Interface
X4	10/100Tbase Ethernet interface with RJ-45 (PoE)

Table 2: Connectors

4.1 Antenna terminal ANT 1

A SMA socket is provided on the circuit board for connecting the external antenna.

The maximum tightening torque for the SMA socket is 0.45 Nm.

Caution:

Higher tightening torque will damage the connector.

Terminal	Description
X4	Connecting the external antenna (input impedance 50Ω)

Table 3: Connecting the external antenna

Note:

- **The input impedance for the antenna must be calibrated to a value of $50 \Omega \pm (15 \Omega \angle 15^\circ)$.**
- **If the antenna ID ISC.ANT340240 is used a minimum distance of 20cm to any metal parts are necessary. Otherwise there is a danger that the reader will be destroyed.**
- **The optimum operating Q factor of the antenna should be in a range of $QB = 10...20$. To determine the operating Q the antenna must be supplied with a 50 Ohm source such as a network analyzer or frequency generator.**
- **When connecting an antenna, ensure that it does not exceed the permissible limits prescribed by the national regulations for radio frequency devices.**

4.1.1 DC Voltage supply on antenna connector ANT1

The reader is able to provide a DC voltage on the antenna output ANT1. With this DC voltage a external LED can be supported for example.

Note:

- **This DC voltage ($7,5V \pm 1V$) is designed for low current (max. 5mA) only.**
- **Only antennas can be used which are designed for DC voltage and do not short cut DC voltages.**
- **For the connection of other devices (e.g. VSWR-Meter) it is necessary to check if DC voltage is allowed.**
- **This DC voltage is not sufficient for powering the ID ISC.DAT tuning board.**

4.2 Power supply

4.2.1 Power supply via X1

The reader has to be supplied by a limited power supply according EN 62368-1 Chapter Q.1, or with a NEC Class 2/LPS certified power supply.

The external wiring for the power supply must be compliant with

- IEC 60332-2-1 and IEC 60332-2-2 for Wire Cross Section < 0.5 mm²
- IEC 60332-1-2 and IEC 60332-1-3 for Wire Cross Section > 0.5 mm²

Connect the 12-24 V DC/⎓ supply voltage to socket X1 on the circuit board.

⎓ Direct current symbol

Terminal	Name	Description	X 1
X1 / inside	Vcc	Vcc – supply voltage (+)	
X1 / outside	GND	Ground – supply voltage (-)	

Table 4: Connecting the supply voltage

Note:

- **Reversing the polarity of the supply voltage may destroy the device.**
- **The unit has to be supplied by a listed NEC Class 2/LPS Power supply, only**

Power supply recommendations:

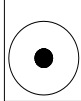
To take full advantage of the Reader performance, you must use a sufficiently regulated and low-noise power supply. When using a switching power supply, be sure that its internal switching frequency is less than 300 kHz. See also: [Accessories](#)

Feig Article No	Name	Description.
1688.002.00	ID NET.12V-B-EU Power Supply Unit 12V	Power Supply 100 - 240V AC Input Voltage, (Continental European Plug), with angular DC Plug 2,5mm*5,5mm Output: 12 V DC/⎓; 700mA Ambient Operating Temperature: 0°C to +40°C

Table 5: Recommended power supply

Note:

The power supply is supplied with a DC/⎓ plug 2.5mm x 5.5mm. This is compatible with the reader's socket X1.

4.2.2 Power supply via PoE (Power over Ethernet) on X4 (ID ISC.MR102-PoE)

Optional the reader (only MR102-PoE) can be powered via the LAN connector on X4 with the use of a PoE „Power over Ethernet“ power supply according to IEEE802.3af*, Class2 (6,49 Watt).

The DC supply can be achieved via the free pin's 4,5 and 7,8 (Midspan-Power). Also a “Phantom Powering” (Inline-Power) via the signal pin's 1,2,3, and 6 is possible.

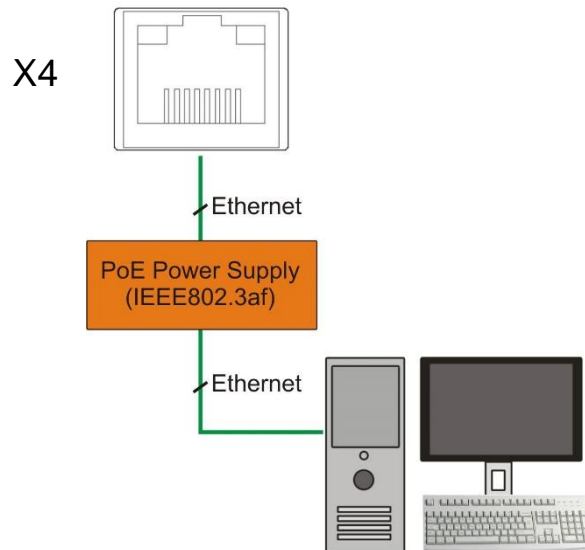

Figure 4: LAN and PoE connection

Note:

- *It must be ensured that the reader is supplied with 42,5 V DC (48 V DC – cable losses) at least.*
- *The maximum cable distance for Ethernet is 100m.*
- *A connection of the PoE Port X4 to devices at outside building installation (e.g. connected to the outside plants) is not allowed.*
- *A shielded twisted pair STP CAT5 cable must be used.*

* For detailed technical information regarding the 802.3af standard, please refer to the most recent edition of the corresponding IEEE specification.

Article No.	Name	Description
3842.000.00	ID NET.PoE113W-A	Power over Ethernet Supply 100-240V AC (Continental European Plug), Output: 48V DC/---; 0,5A

Table 6: Recommended PoE Power Supply

4.3 Power supply and interface connection on X2 (ID ISC.MR102-A)

For the power supply connection and the connection of the asynchronous interface RS232 / 485 the reader provides a 9-pin D-Subminiature female connector.

(See also connections).

X2	Interface + Power supply
2	TxD
3	RxD
5	GND
7	GND
9	Vcc
1;4;6;8	n.c.

Table 7: Connection assignment of the connector X2

For this reader a serial cable with integrated DC connector is available.

Serial [data cable ID CAB.RS-A](#)).

Feig Part No.	Description
1690.000.00	ID CAB.RS-A

Table 8: Serial data cable

4.3.1 RS232 Interface (ID ISC.MR102-A)

Interface parameter can be configured via software protocol (e.g. ISOStart)

4.4 Ethernet-Interface on X2 (10/100Tbase)

The Reader has an integrated 10 / 100 base-T network port for an RJ-45. Connection is made on X2 and has an automatic "Crossover Detection" according to the 100BASE-T Standard.

With structured cabling CAT 5 cables should be used. This ensures a reliable operation at 10 Mbps or 100 Mbps.

The prerequisite for using TCP/IP protocol is that each device has a unique address on the network. All Readers have a factory set IP address. Interface parameter can be configured via software protocol (e.g. ISOStart).

Network	Address
IP-Address	192.168.10.10
Subnet-Mask	255.255.255.0
Port	10001
DHCP	OFF

Table 9: Standard factory configuration of the Ethernet connection

Note:

- *The reader provides a DHCP able TCP/IP interface.*
- *A shielded twisted pair STP CAT5 cable must be used.*

4.5 USB – Interface X3 (Host communication)

There is a USB-socket X3 on board for the connection of the USB-Interface. The pinout is standardized. The data rate is reduced to 12 Mbit (USB full speed). A standard USB-cable can be used.

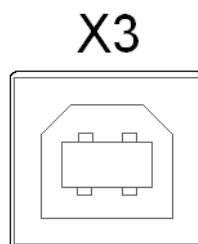

Figure 5: USB interface for the host communication

Note:

The length of the USB-cable can be a max. of 5 meter. It isn't allowed to use longer cables!

5 Control and display elements LED

5.1 LED

The Reader's LED can be configured through software.



The following [Table 10](#) shows the default setting.

Abbreviation	Description
LED green	"RUN " - Turns on when the Reader is ready
LED red	„LABEL“ - Turns on when a transponder is detected. - Flashes if a RF-Warning appears (red – green alternating with 8Hz) (Temperature alarm, short circuit on antenna output)
LED orange	„INITIALIZING“ - Flashes during Reader initialization after power-up.

Table 10: Default configuration of the LEDs

6 Radio Approvals

6.1 Declaration of Conformity (CE), (UKCA)

	<p>Declaration of Conformity (CE)</p> <p>Hereby, FEIG ELECTRONIC GmbH declares that the radio equipment type ID ISC.MR102 is in compliance with Directive 2014/53/EU.</p> <p>The full text of the EU declaration of conformity is available at the following internet address: https://www.feig.de/en/service/eu-declarations-of-conformity/</p>
	<p>UKCA Declaration of Conformity</p> <p>Hereby FEIG ELECTRONIC GmbH declares that the radio equipment type ID ISC.MR102 is in compliance with Directive No. 1206 Radio Equipment Regulations 2017.</p> <p>The full text of the UKCA declaration of conformity is available at the following internet address: https://www.feig.de/en/service/ukca-declarations-of-conformity/</p>

6.2 USA (FCC) and Canada (IC)

Product names:	ID ISC.MR102-A, ID ISC.MRM102-A, ID ISC.MR102-B, ID ISC.MR102-USB, ID ISC.MRM102-USB, ID ISC.MR102-PoE
Reader name:	ID ISC.MR102
FCC ID: IC:	PJMMR102 6633A-MR102
Notice for USA and Canada	<p>This device complies with Part 15 of the FCC Rules and with RSS-210 of Industry Canada.</p> <p>Operation is subject to the following two conditions.</p> <p>(1) this device may not cause harmful interference, and</p> <p>(2) this device must accept any interference received, including interference that may cause undesired operation.</p> <p>Unauthorized modifications may void the authority granted under Federal communications Commission Rules permitting the operation of this device.</p> <p>This equipment has been tested and found to comply with the limits for a Class A digital device, pursuant to Part 15 of the FCC Rules. These limits are designed to provide reasonable protection against harmful interference when the equipment is operated in a commercial environment. This equipment generates, uses, and can radiate radio frequency energy and, if not installed and used in accordance with the instruction manual, may cause harmful interference to radio communications. Operation of this equipment in a residential area is likely to cause harmful interference in which case the user will be required to correct the interference at his own expense.</p> <p>Le présent appareil est conforme aux CNR d'Industrie Canada applicables aux appareils radio exempts de licence. L'exploitation est autorisée aux deux conditions suivantes :</p> <p>(1) l'appareil ne doit pas produire de brouillage, et</p> <p>(2) l'utilisateur de l'appareil doit accepter tout brouillage radioélectrique subi, même si le brouillage est susceptible d'en compromettre le fonctionnement.</p>

Warning: Changes or modification made to this equipment not expressly approved by FEIG ELECTRONIC GmbH may void the FCC authorization to operate this equipment.

Installation with FCC / IC Approval:

FCC-/IC-NOTICE: To comply with FCC Part 15 Rules in the United States / with IC Radio Standards in Canada, the system must be professionally installed to ensure compliance with the Part 15 certification / IC certification. It is the responsibility of the operator and professional installer to ensure that only certified systems are deployed in the United States / Canada.

Following antennas are approved by FCC according FCC Part 15 and IC Canada according RS210:



- ID ISC.ANT40/30
- ID ISC.ANT100/100
- ID ISC.ANT310/310
- ID ISC.ANT340/240
- ID ISC.ANTS370/270
- ID ISC.ANT800/600

6.3 UL Approval - USA and Canada

The following UL label position is on the back side of the reader.

ID ISC.MR102-A	ID ISC.MRM102-A
 <p>FEIG ELECTRONIC ID ISC.MR102-A FCC ID: PJMMR102 IC: 6633A-MR102 Input 12-24V --- max. 0.5A This device complies with Part 15 of the FCC Rules. Operation is subject to the following two conditions: (1) this device may not cause harmful interference, and (2) this device must accept any interference received including interference that may cause undesired operation. This unit has to be supplied by a Listed NEC Class 2/LPS Supply only. For use with connections to Listed ITE equipment and accessories only. Made in Germany</p>	 <p>FEIG ELECTRONIC ID ISC.MRM102-A FCC ID: PJMMR102 IC: 6633A-MR102 Input 12-24V --- max. 0.5A This device complies with Part 15 of the FCC Rules. Operation is subject to the following two conditions: (1) this device may not cause harmful interference, and (2) this device must accept any interference received including interference that may cause undesired operation. This unit has to be supplied by a Listed NEC Class 2/LPS Supply only. For use with connections to Listed ITE equipment and accessories only. Made in Germany</p>
ID ISC.MR102-PoE	
 <p>FEIG ELECTRONIC ID ISC.MR102-PoE FCC ID: PJMMR102 IC: 6633A-MR102 Input 12-24V --- max. 0.5A This device complies with Part 15 of the FCC Rules. Operation is subject to the following two conditions: (1) this device may not cause harmful interference, and (2) this device must accept any interference received including interference that may cause undesired operation. This unit has to be supplied by a Listed NEC Class 2/LPS Supply only. For use with connections to Listed ITE equipment and accessories only. Made in Germany</p>	
ID ISC.MR102-USB	ID ISC.MRM102-USB
 <p>FEIG ELECTRONIC ID ISC.MR102-USB FCC ID: PJMMR102 IC: 6633A-MR102 Input 12-24V --- max. 0.5A This device complies with Part 15 of the FCC Rules. Operation is subject to the following two conditions: (1) this device may not cause harmful interference, and (2) this device must accept any interference received including interference that may cause undesired operation. This unit has to be supplied by a Listed NEC Class 2/LPS Supply only. For use with connections to Listed ITE equipment and accessories only. Made in Germany</p>	 <p>FEIG ELECTRONIC ID ISC.MRM102-USB FCC ID: PJMMR102 IC: 6633A-MR102 Input 12-24V --- max. 0.5A This device complies with Part 15 of the FCC Rules. Operation is subject to the following two conditions: (1) this device may not cause harmful interference, and (2) this device must accept any interference received including interference that may cause undesired operation. This unit has to be supplied by a Listed NEC Class 2/LPS Supply only. For use with connections to Listed ITE equipment and accessories only. Made in Germany</p>

7 Technical Data

Mechanical Data	
Housing	ABS plastic closed
Weight	200 g / 0,44 lbs
Dimensions (W x H x D)	85 x 145 x 27 mm (3,35 x 5,71 x 1,06 in)
Degree of Protection	IP 30
Color	similar RAL 9018 (papyrus white)
Electrical Data	
Power supply – ID ISC.MR102-A/-B/-USB – ID ISC.MR102-PoE	12 ...24V DC/  12 ...24V DC/  or PoE
Power consumption	max. 6 W
Antenna DC voltage	7,5V DC ± 1V (5mA) on antenna output (e.g. for support of external LED)
Antenna Connection	SMA female (50Ω)
Operating frequency	13,56 MHz
RF transmitting power	1,2 W ± 1 dB
Supported Transponder	<ul style="list-style-type: none"> • ISO15693, ISO18000-3 MODE 1 (EM HF ISO Chips, Fujitsu HF ISO Chips, KSWSensor Chips, Infineon my-d, NXP I-Code, STM ISO Chips, TI Tag-it) • ISO18000-3M3 (Upgrade Code required) • NXP I Code 1
Protocol Modes	ISO Host Mode Scan Mode
Indicator	1 x LED (multicolor – red / green)
Interfaces – ID ISC.MR102-A – ID ISC.MR102-PoE – ID ISC.MR102-USB	RS232 USB 2.0 Ethernet (TCP/IP)
Address setting for interface	Software (0- 254 Addresses)
Features	<ul style="list-style-type: none"> - Short circuit detection (antenna) - Temperature control - Support of external multiplexer ID ISC.ANT.MUX (in Host Mode)

Environmental Conditions

Temperature range	Operation	-25°C to +55°C / -13°F to +131°F
	Storage	-25°C to +45°C / -13°F to +113°F (PoE) -25°C to +85°C / -13°F to +185°F
Humidity		5% - 95% (non-condensing)
Vibration		EN 60068-2-6 10 Hz to 150 Hz : 0,075 mm / 1 g
Shock		EN 60068-2-27 Acceleration: 30 g

Applicable Standards

RF Approval	Europe	EN 300 330
	UK	EN 300 330
	USA	FCC 47 CFR Part 15
	Canada	IC RSS-GEN, RSS-210
EMC		EN 301 489
Safety	Low Voltage	EN 62368-1
	Human Exposure	EN 50364

8 Annex

8.1 Accessories

The following accessories are available for the Reader.

Article No.	Name	Description
1688.002.00	ID NET.12V-B-EU Power Supply Unit 12V	Power Supply 100 - 240V AC Input Voltage, (Continental European Plug), with angular DC Plug 2,5mm*5,5mm Output: 12 V DC/---; 700mA Ambient Operating Temperature: 0°C to +40°C
3842.000.00	ID NET.PoE113W-A	Power over Ethernet Supply 100-240V AC (Continental European Plug), Output: 48V DC/---; 0,5A
1691.000.01	ID ISC.MS.MR/PR-A	Wall mounting kit for ID ISC.MR102
1690.000.00	ID CAB.RS-A	Serial data cable with integrated supply voltage line
1686.000.00	ID CAB.USB-A	USB-cable 2,5m
1687.000.00	ID CO.RS232/485	External RS232/RS485 converter
1663.000.00	ID ISC.ANT340/240-A	External antenna Dimensions: 340mm x 240mm x 9mm Degree of Protection: IP20
2396.000.00	ID ISC.ANT340/240-B	External antenna without housing
3249.000.00	ID ISC.ANT310/310-A	External antenna Dimensions: 318mm x 338mm x 30mm Degree of Protection: IP65
3512.000.00	ID ISC.ANTS370/270-A	External antenna Dimensions: 370mm x 270mm x 27mm Degree of Protection: IP20
1968.000.00	ID ISC.ANT100/100-A	External antenna (PCB board) Dimensions: 40mm x 30mm x 6mm
1967.000.00	ID ISC.ANT40/30-A	External antenna (PCB board) Dimensions: 100mm x 100mm x 6mm

Table 11: Accessories

8.1.1 Wall mounting kit ID ISC.MS.MR/PR-A

The wall mounting kit can be used to attach the Reader to a flat surface.

- Remove the screws from the back side of the Reader.
- Attach the individual wall hangers using the screws supplied with the mounting kit.

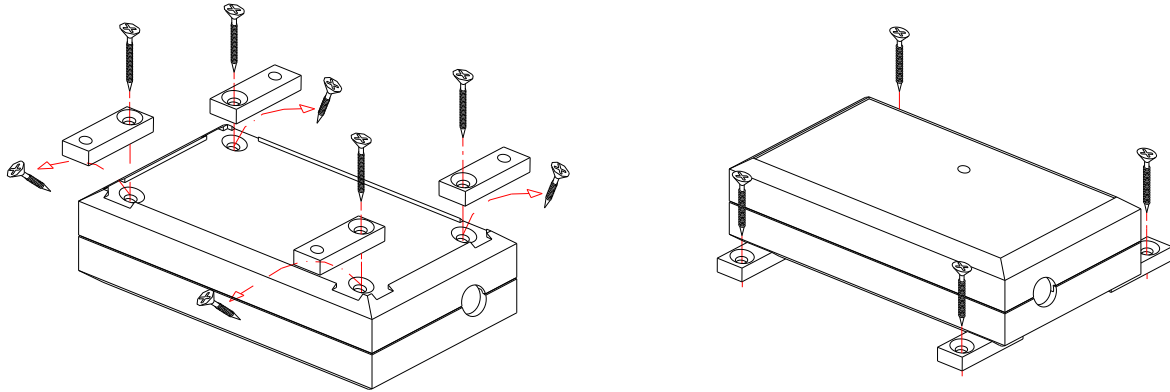

Figure 6: Mounting wall hangers

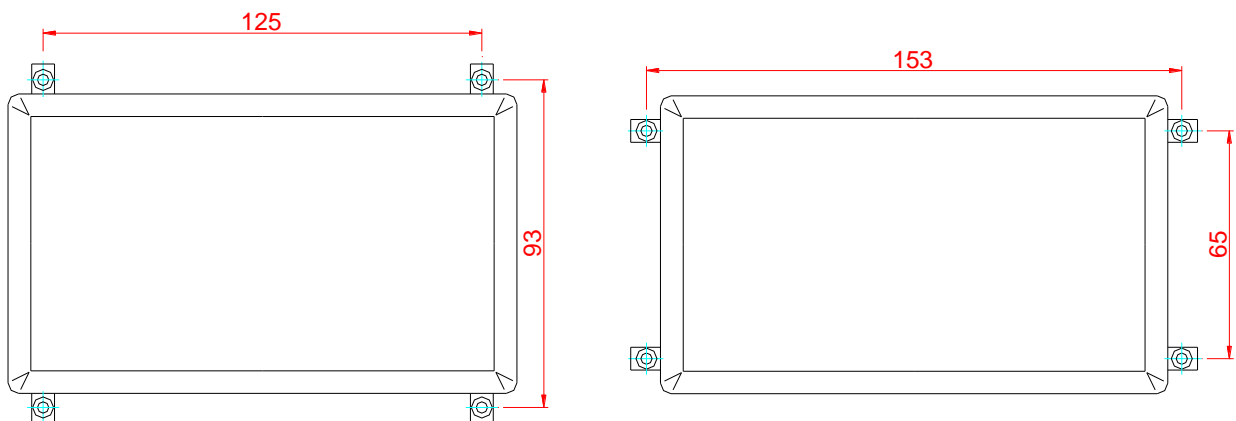

Figure 7: Mounting drill dimensioning (all dimensions in mm)

8.1.2 Serial data cable ID CAB.RS-A

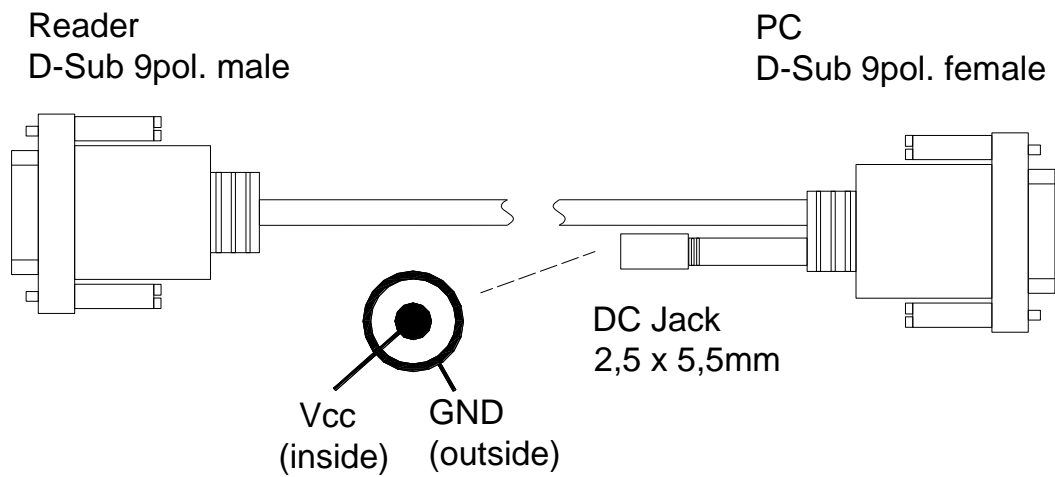

Figure 8: Serial data cable with supply voltage connection

8.1.3 Antenna



Figure 9: ID ISC.ANT340/240



Figure 10: ID ISC.ANT310/310

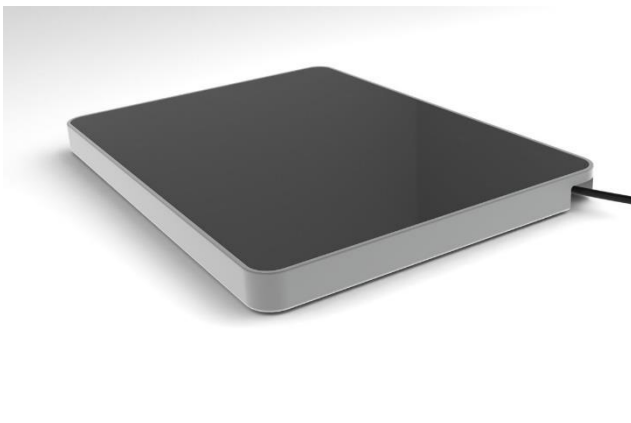

Figure 11: ID ISC.ANTS370/270