

Professional Mixers



From Fender Pro Audio

Owner's Manual for
MX 5216, MX 5224,
and MX 5232

P/N 048846

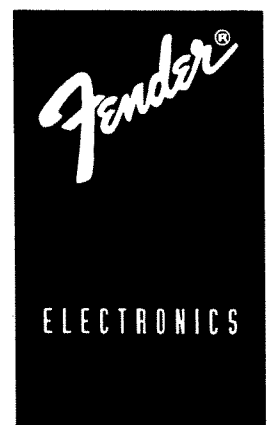

INTRODUCTION

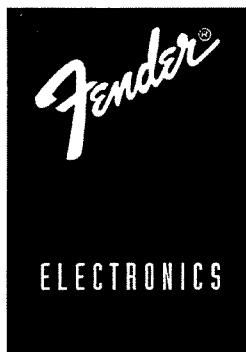

Dear Customer,

Congratulations on purchasing your new MX-5200 Series mixing console—and thank you! Whether you purchased the MX-5216 (16 input channels), MX-5224 (24 input channels), or MX-5232 (32 input channels), you now have one of the finest instruments available to the sound engineer/producer.

The modular MX-5200 Series mixers, along with options such as the proprietary Fender Sysflex™ expansion system or Fender MX-AutoSoft™ automation system, provide quality, features, flexibility, and performance beyond any product in its class.

With or without optional equipment, the MX-5200 Series has the features and versatility to allow you to be at your creative best. Even though the MX-5200 Series is easy to use, and has the features and performance to allow you to quickly begin hassle-free mixing, please read this manual anyway (particularly the Getting Started section). After all, we want you to have the most pleasant and efficient sound experience possible, using the MX-5200 as your creative tool.

P.S.— For more information on the fundamentals of working with sound-reinforcement and recording gear, including mixing consoles, check out Tom Butler's *Making The Connection—The Fender Pro Audio Primer*. Visit your nearest Fender dealer, or contact Fender Musical Instruments Corp. directly.

Happy mixing!

Your friends at Fender

PICTOGRAPHIC TABLE OF CONTENTS (FAST-FIND)

The circled numbers in these diagrams quickly guide you to the pages containing information on each of the MX-5200 Series mixers' features. A full table of contents is located on pages 4 through 6.

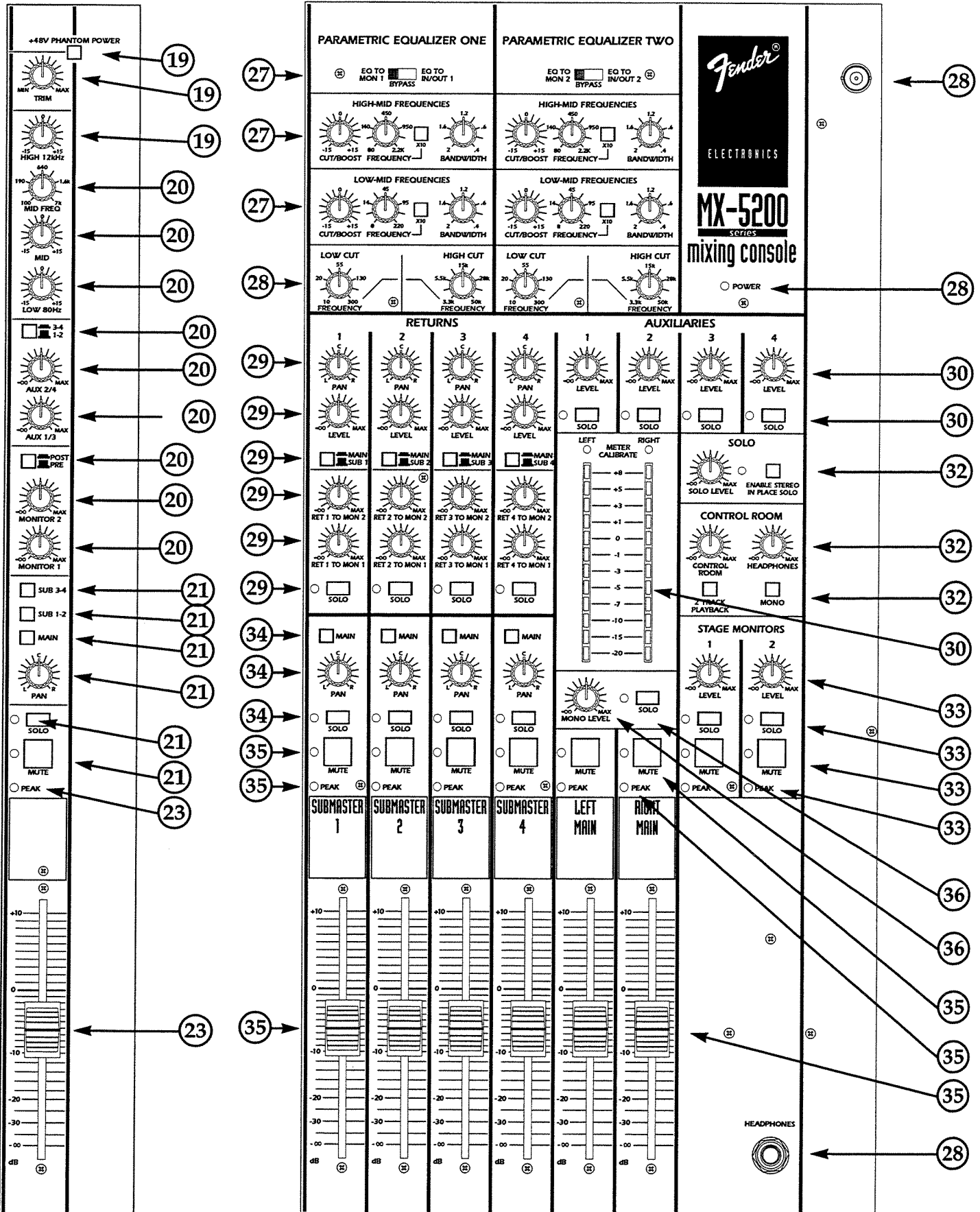

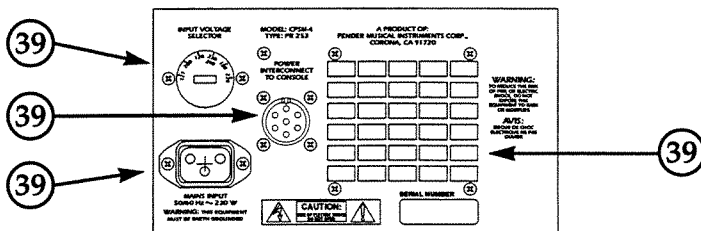
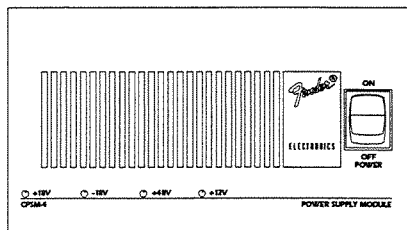
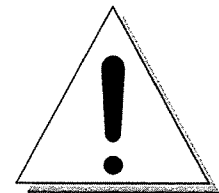
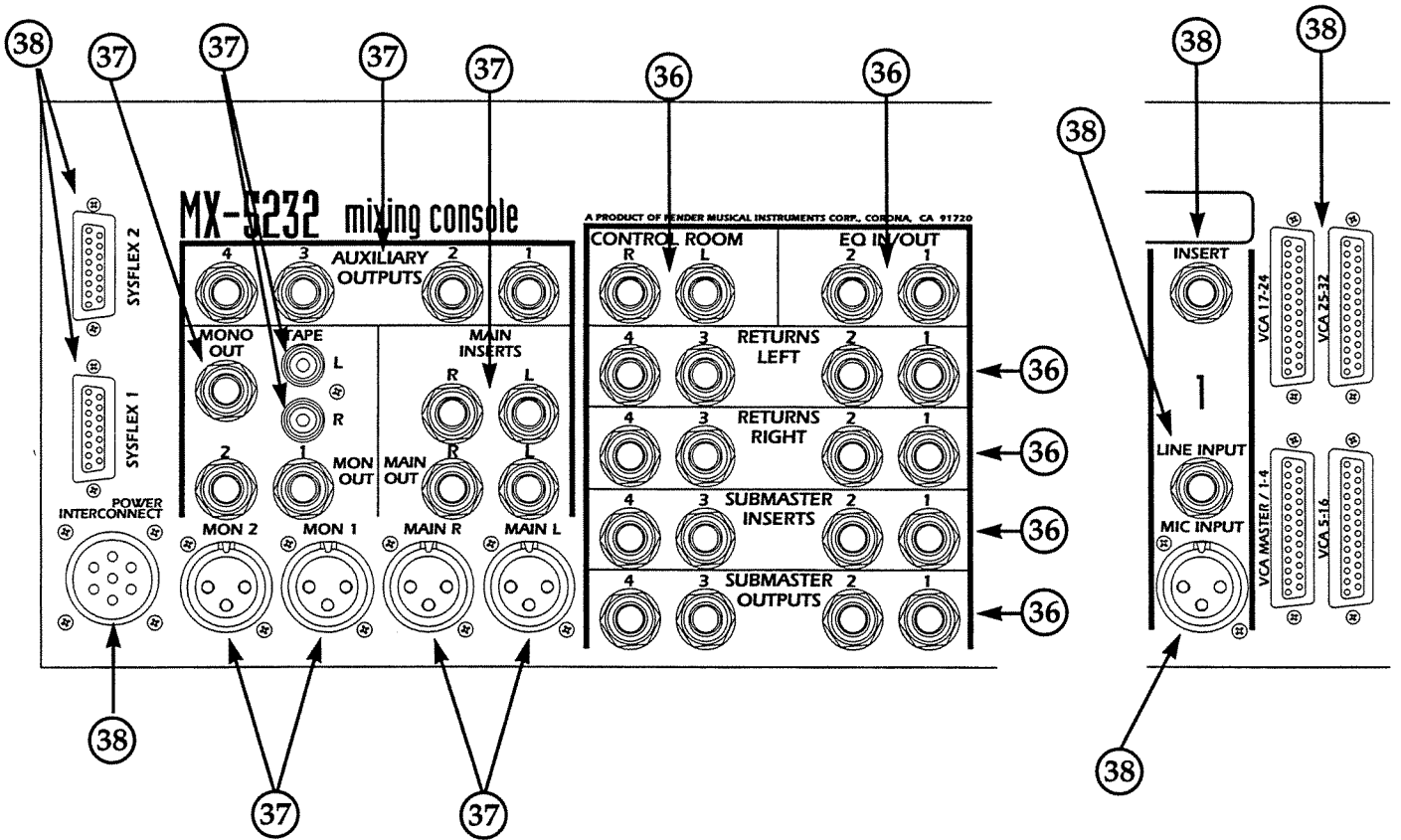

OTHER IMPORTANT INFORMATION

- Safety Information 7
- Getting Started 10
- Block Diagram 16
- Troubleshooting 40
- Specifications 41
- Warranty 44
- Setup Examples 45

TABLE OF CONTENTS

Introduction	1
Pictographic Table Of Contents (Fast-Find)	2
Safety Information	7
Features	7
Standard MX-5200 Features	7
Input Channel Features	8
Master Module Features	9
Power Supply Features	10
Getting Started	10
Unpacking	10
Power Supply Connection And Checkout	10
Warnings	10
Turning On The Power Supply For The First Time	11
Connecting The Power Supply To The Mixer	11
Start-Up Control Positions	12
Basic Audio Connections	13
Connecting The MX-5200 To Recording & Sound Reinforcement Gear ..	13
Mains	13
Control Room & Headphones	13
Stage Monitors	14
Mono	14
Submasters	15
Auxiliaries	15
Block Diagrams	16
Block Diagram Of MX-5200 Series Mixer	16
Legend For MX-5200 Series Mixer Block Diagram	18
Channel Input Section	19
+48V Phantom Power	19
Trim	19
EQ Section	19
High EQ	19
Mid Frequency & Mid	20
Low EQ	20
Aux Bus Send Controls	20
Stage Monitor Send Section	20
Submaster/Fader Bus Assignment Section	21
Solo/Mute Section	21
Mute Switch	21
Solo Switch	21
PFL Solo Mode	21
Stereo In Place Solo Mode	21
Quick Solo & Mute Reference	22
Solo Functions	22
Mute Functions	23
Peak LED	23
Channel Fader	23
Input Channel Rear-Panel Jacks	23
Mic Input	23

Line Input	23
Insert Jack	24
Master Module Section	26
Parametric Equalizer Section	26
EQ To Mon 1 • Bypass • EQ To In/Out 1 Switch	27
High-Mid Frequencies	27
Cut/Boost Control	27
Frequency Control & Frequency Multiplier (x10) Switch	27
Bandwidth Control	27
Low-Mid Frequency Band	27
Cut/Boost Control	28
Frequency Control And Frequency Multiplier (x10) Switch	28
Bandwidth Control	28
Low Cut Control	28
High Cut Control	28
Power Indicator LED	28
BNC Connectors For Console Illumination	28
Headphones Jack	28
Return Section (1-4)	29
Pan Control & Main/Sub 1 (2, 3, Or 4) Selector Switch	29
Level Control	29
Ret 1 (2, 3, Or 4) To Mon 1 (Stage Monitor Mix 1) Level Control ..	29
Ret 1 (2, 3, Or 4) To Mon 2 (Stage Monitor Mix 2) Level Control ..	29
Solo Switch	29
Solo LED Indicator	30
Auxiliary Master Level Controls (1-4)	30
Level Control (1-4)	30
Solo Switch & Solo LED Indicator	30
Meter Section	30
Meter Calibration Procedure	31
Solo Section	32
Solo Level Control	32
Enable Stereo In Place Solo Switch	32
Control Room Section	32
Control Room Level Control	32
Headphones Level Control	32
2 Track Playback Switch	32
Mono Switch	32
Stage Monitors	33
Monitor (Master) Level Control (1-2)	33
Monitor Solo Switch & LED Indicator	33
Monitor Mute Switch & Mute LED Indicator	33
Peak Indicator LED	33
Submaster Section (1-4)	34
Submaster Main (Assignment) Switch	34
Pan Control	34
Solo Switch & LED Indicator	34
Mute Switch & Led Indicator	35
Peak Indicator LED	35
Submaster Fader	35

Table Of Contents, continued

Stereo Main Mix (Master) Section.....	35
Left Main	35
Left Main Mute Switch & LED Indicator.....	35
Peak Indicator LED	35
Left Main Fader	35
Right Main.....	35
Right Main Mute Switch & LED Indicator	35
Peak Indicator LED	35
Right Main Fader	35
Mono Master Level	36
Mono Master Solo Switch & LED Indicator	36
Rear Panel	36
Control Room Outputs (L&R).....	36
EQ In/Out.....	36
Returns (Left 1-4 & Right 1-4)	36
Submaster Inserts 1-4.....	36
Submaster Outputs 1-4	36
Auxiliary Outputs 1-4	37
Mono Out	37
Tape In, Left & Right	37
Main Inserts, Left & Right	37
Monitor Outs 1&2	37
Main Out Left & Right.....	37
Channel Inputs & Inserts.....	38
Channel Insert/Direct Out Jack.....	38
Line Input	38
Mic Input (XLR)	38
Other Rear-Panel Connections.....	38
Sysflex™ Expansion Ports	38
Power Interconnect	38
VCA Control Option	38
The Power Supply.....	39
Troubleshooting Your Mixer.....	40
Power	40
Power Amp & Speakers	40
Mixer & Sound Source	40
Specifications For Fender MX-5200 Series Mixers.....	41
Interconnecting Cables, Grounding, And Troubleshooting	42
Fender Electronic Products Limited Warranty	44
Setup Examples	45
A Small Mono P.A. System With Stage Monitors & Stereo Recording Mix	45
A Small Stereo P.A. With Two External Monitor Systems, Front Of House Cue Wedge, Mono Subwoofer, And A Stereo Recording Mix	46
Stereo Bi-amplified Sound System For A Small Club.....	47
A Large Stereo Triamped P.A.	48
A Large Onstage Monitor Mixing System.....	50
A Multi-Track Home/Project Studio System	52

SAFETY INFORMATION

Throughout this manual, the lightning flash with an arrowhead symbol within a triangle alerts the reader to the presence of uninsulated "dangerous voltages" within the product's enclosure that may be of sufficient magnitude to constitute a risk of electric shock.

The exclamation point within a triangle alerts the reader to the presence of important operating or maintenance instructions.

Warning: To avoid the risk of shock or fire, do not expose the mixer or the power supply to moisture. Do not remove metal covers or open the chassis. There are no user-serviceable parts inside the mixer or its power supply. Opening the power supply's enclosure exposes dangerous high voltages. Refer all servicing to qualified personnel.

Caution: Always make sure that the power supply's AC (Mains) voltage selector is set to the correct voltage, and use the proper type of AC line cord for the selected voltage. Always transport your mixer and power supply securely, either in a suitable flight case or in the original packing materials as shipped from the factory.

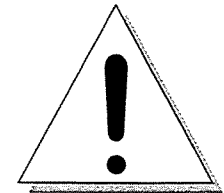
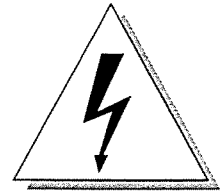

FEATURES

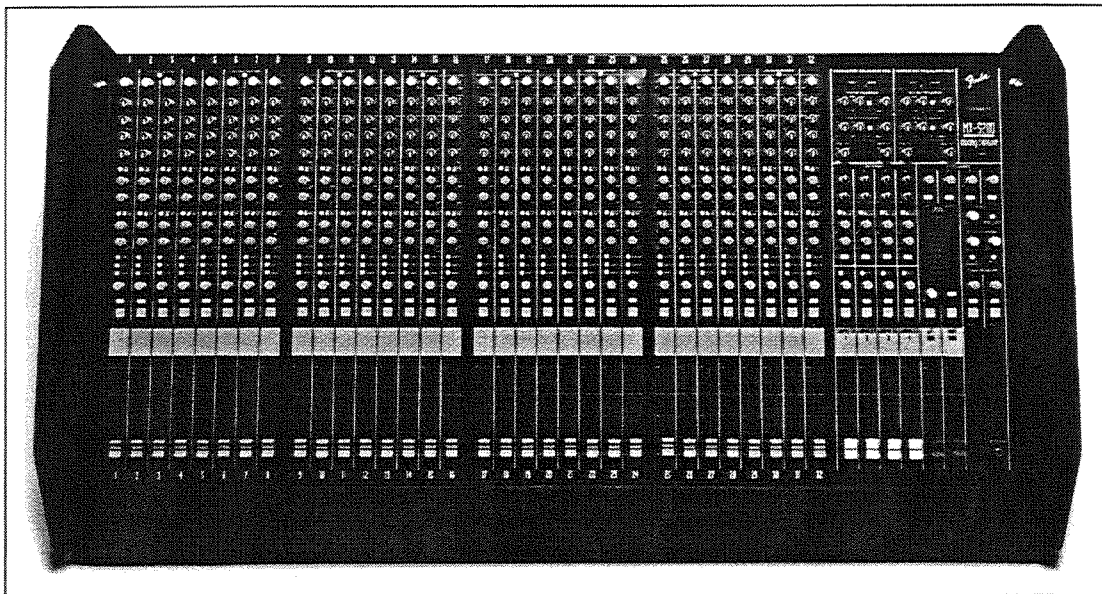

Standard MX-5200 Series Features

- 16, 24, or 32 Input Channels on modular panels (in groups of eight)
- Comprehensive, separate Master Section module
- Separate half-rack-size power supply unit
- Four Submasters, Stereo Mains, two Stage Monitor Sends, four Auxiliary Sends
- Comprehensive input and output connections, all on the rear panel

Input Channel Features

- Balanced XLR mic input with switchable +48V phantom power
- Studio-grade low-noise/high-headroom mic preamp
- Balanced or unbalanced 1/4" TRS line input
- 1/4" TRS channel patch point (Insert send/return)
- Flexible 3-band equalizer (80 Hz low shelving, sweepable midrange peak/dip, and 12kHz high shelving)
- Switchable Pre/Post selection for monitor sends
- Aux Sends switchable for routing to Aux Buses 1 and 2 or to Aux Buses 3 and 4
- Switchable assignment to Sub 1-2, Sub 3-4, and/or Main L-R
- Single Solo switch provides Stereo In Place Solo or PFL Solo, in combination with Master Section switch
- LED indicators for Mute, Solo, and Peak
- Dual-rail 100mm precision fader, connectorized for easy replacement
- Optional VCA automation of 100mm faders and Mute switch

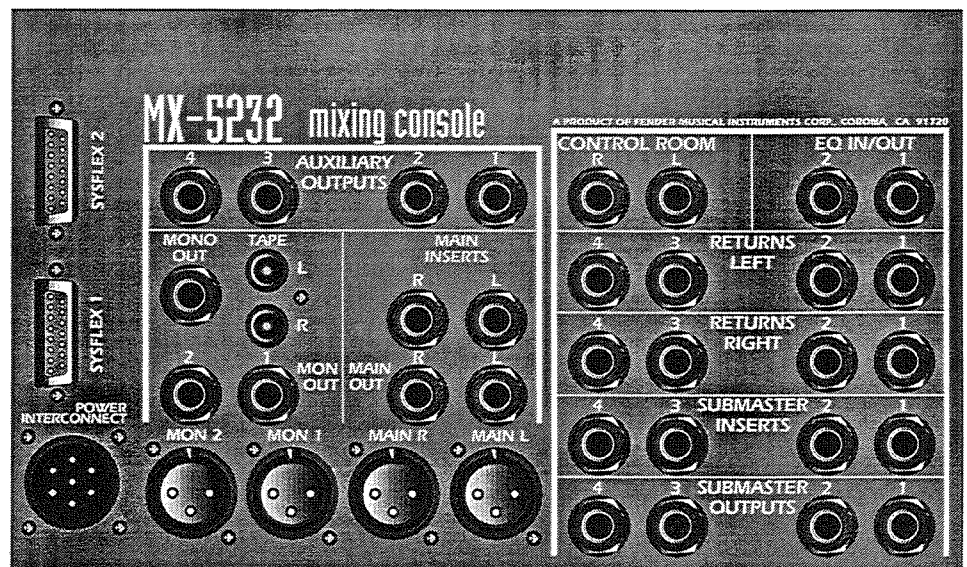
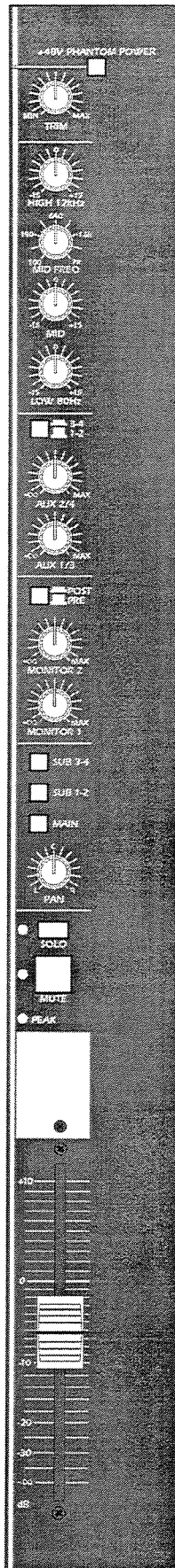
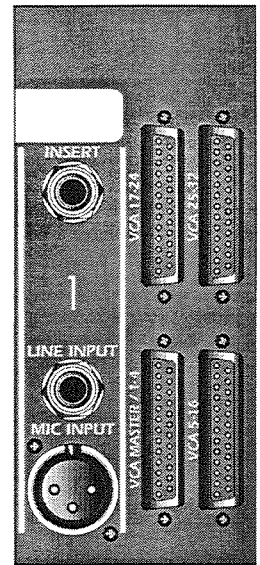

Master Module Features

- Dual-rail 100mm precision faders for Subs 1-4 and Main Left and Right
- Four Submasters, each with Mute switch/LED, Solo switch/LED, Peak LED, and Pan/Assign to Main L-R
- Balanced Main Left and Right outputs, each with Mute switch/LED and Peak LED
- Balanced Mono sum output (of Left and Right Mains) with rotary Level control and Solo switch/LED
- Two balanced Stage Monitor outputs, each with Mute switch/LED, Solo switch/LED, Peak LED, and rotary Master Level control
- Four Aux Send masters, each with Solo switch/LED and rotary Master Level control
- Four comprehensive stereo or mono Effects Returns sections, each with return level, pan pot, assignment to either Stereo L-R or to Submasters, Solo switch/LED, and independent Return Level to Monitor controls
- Stereo 12-segment LED bargraph meters (with VU ballistics and peak hold) follow the Solo signal or Main L-R, with front-panel accessible calibration trim controls
- Master switch to allow either Pre Fader Listen (PFL) or Stereo In Place Solo
- Master Solo Level control
- High-powered headphone amp with separate level control and front-panel-mounted output jack
- Separate line-level stereo Control Room monitor outputs, with stereo rotary Level control, switchable 2 Track Tape Playback input, and Mono switch
- A pair of 2-band, fully parametric equalizers and sweepable high-pass and low-pass filters that can be switched into Monitors 1-2 or accessed via rear-panel patch-point jacks
- Optional VCA automation of all 100mm faders and all Mute switches
- Optional meter bridge with analog VU meters for all main Master Section signals
- Optional Sysflex™ system to link two or more MX-5200 Series mixers together

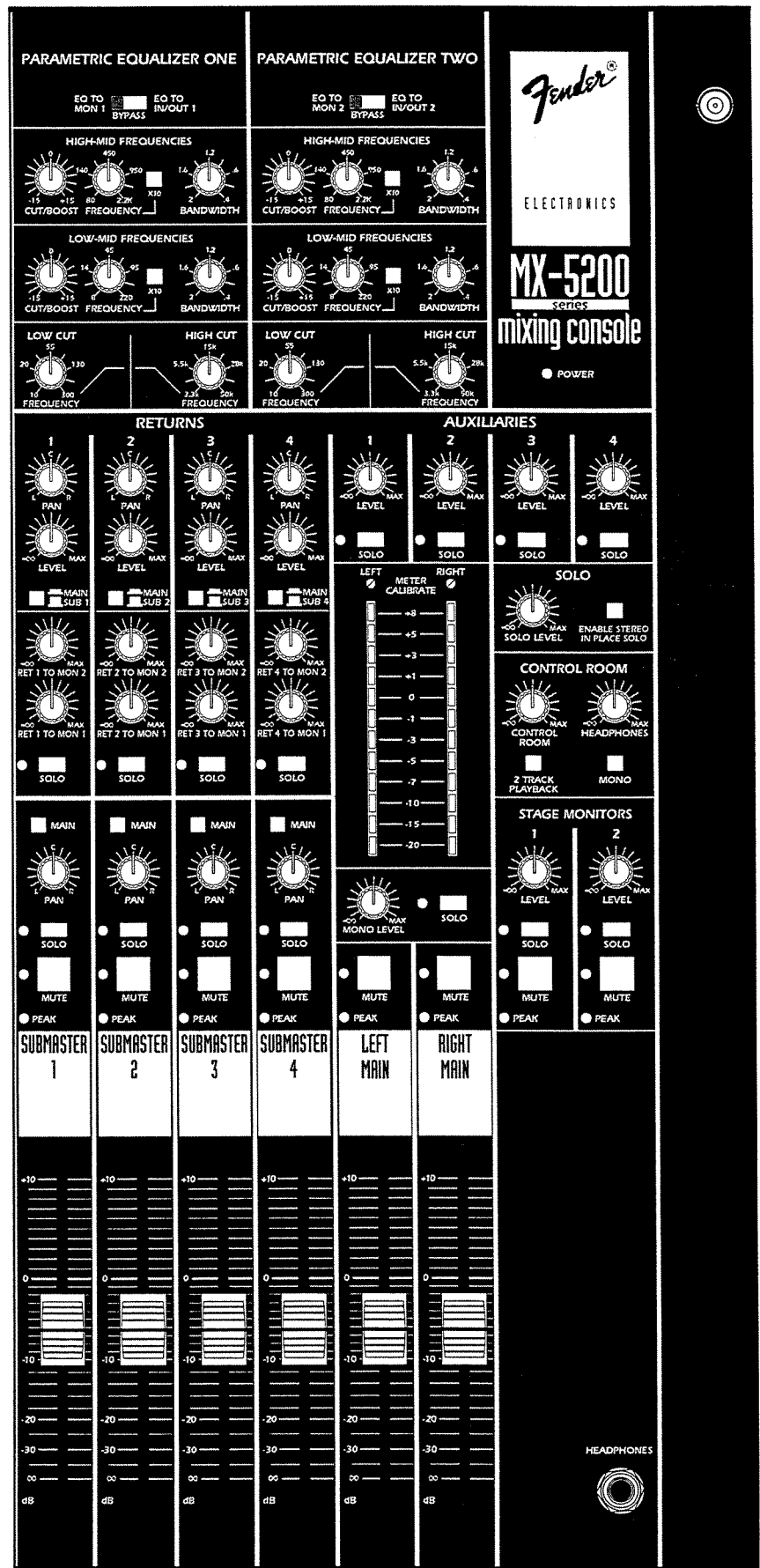

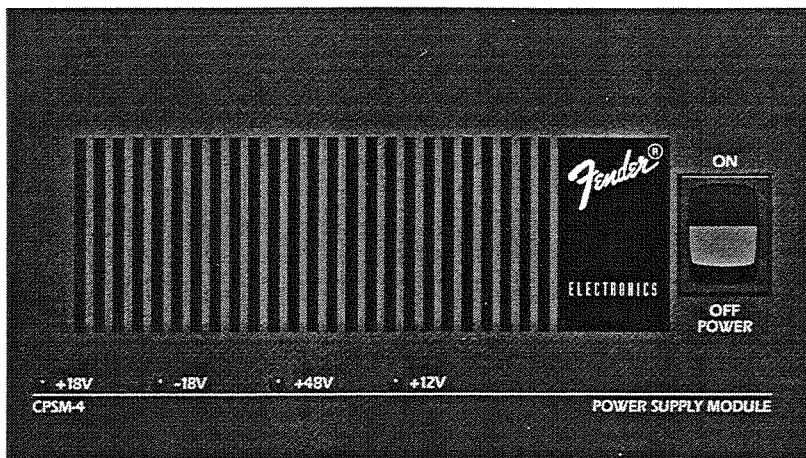

Power Supply Features

- Separate power supply in a compact half-rack-size metal enclosure, with secure connection to mixer via a single cable with a multi-pin, locking circular connector at each end
- Over-designed specifications and fan-cooled operation for maximum reliability
- Universal supply with selectable AC (Mains) voltages of 100, 120, 127, 200, 220, or 230/240VAC
- Detachable IEC line cord
- Provides +18V and -18V (audio supplies), +48V (phantom power), and +12V (lamp supply)
- Optional rack-mounting kit that will hold one or two power supplies
- Optional redundant fail-safe power-supply kit, linking two supplies together for automatic change-over in the event of a failure in one power supply

GETTING STARTED

Please read the following section carefully before attempting to hook up or use your MX-5200 Series mixer.

Unpacking

Immediately after unpacking the mixer, inspect it for obvious damage. While the mixer was thoroughly tested and inspected prior to shipment, damage sometimes occurs during transportation. Also check that the following items have been shipped with the mixer and power supply:

- Detachable AC (Mains) power cord
- Multi-pin cable with circular connectors for attaching the supply to the mixer.

If any items are missing or if damage has occurred, contact your authorized Fender dealer.

Save the original box and packing materials, which were designed to protect the mixer during shipment. Using the original box and packing materials will help to ensure safe transit (in lieu of a flight case) if the mixer must ever be shipped.

Power Supply Connection And Checkout

Failure to abide by the procedures in this section could be hazardous to your health or to that of your equipment. Please read and follow instructions carefully.

WARNINGS



Caution: Before turning on the power switch on the Console Power Supply Module (CPSM-4) or connecting the supply to the mixer, make sure the appropriate AC (Mains) cord is plugged into the Mains input on the rear of the power supply, and that the Input Voltage Selector rotary switch is set to correspond with the proper AC (Mains) voltage. Improper AC (Mains) voltage selection will damage the power supply and could be a fire hazard.



Caution: Always make sure that the CPSM-4 is earth-grounded. Do not remove the ground pin from the AC (Mains) cord. If the cord is damaged, replace it with the same type.



Caution: Never operate the power supply in wet locations.

Caution: Never block the fan ventilating slots at the front and rear of the CPSM-4 power supply. The vents must be free from obstruction, or the unit may overheat, causing damage and risk of fire.



Turning On The Power Supply For The First Time

After observing the above cautions and before connecting the CPSM-4 to the mixer, turn on the power supply. If all of the LEDs on the front of the supply fail to illuminate, check the AC (Mains) cord and the AC (Mains) source to be sure that the unit is receiving power. If the AC (Mains) power is being supplied and any or all of the LEDs still fail to light, contact your authorized Fender dealer or service center.

Connecting The Power Supply To The Mixer

If the power supply panel LEDs all light properly, turn the supply off again and use the 9' multi-pin cable with circular connectors to connect the power supply to the mixer. Insert the cable end with the female contacts into the receptacle on the back of the mixer and turn the twist-lock ring until the connection is tight. Similarly, make a tight connection from the end of the cable with male contacts into the receptacle on the back of the power supply.

Caution: Never connect or disconnect the power supply from the mixer when the power switch is on. Inadvertent short-circuits could occur that would damage the mixer or the power supply.

After making sure the power interconnect cable's connections are tight and the cable is in good condition, turn on the power switch and again observe the four LEDs on the CPSM-4 power supply's front panel. Also observe the green Power LED in the upper right corner of the mixer's Master Module. All LEDs should be brightly lit, indicating that the power supply is operating and the mixer is receiving power.

If any LEDs fail to light, turn off the power supply immediately and consult the troubleshooting section of this manual.



START-UP CONTROL POSITIONS

Anytime a new mix is started or a new mixer configuration is checked out, the control knobs and switches should be set to the following positions in order to minimize noise, allow for the best frequency response and distortion, etc. Use these knob and switch settings as the "normal" setup unless otherwise specified, or until a control position needs to be changed.

It is particularly important that output controls going to amps and speakers be turned all the way down before turning power to the mixer on or off.

Control Type	Normal Position	Examples
Center-detent Rotary Controls	Place in the center-detent position.	EQ boost/cut knobs, pan pots
100mm Slide Faders	Start with fader fully down ($-\infty$). After power-up, pull faders up towards 0 only on input channels and outputs that are to be used. Leave all others fully down.	Channel fader, Sub 1-4 faders, Main L and Main R faders
Rotary Frequency Controls for EQ	Start with controls toward extremes of audio band (i.e., towards 20 Hz or 20kHz).	Channel EQ Mid frequency control, Frequency controls on Parametric EQ, sweepable High Cut and Low Cut filters in Master Module
Other Non-detented Rotary Controls	Fully counterclockwise (Min) at start. After power-up, turn controls clockwise as needed, leaving unused controls all the way down.	Aux. and Monitor Sends, Channel Trim controls, Master Aux. controls, Monitor controls, Control Room and Headphone outputs, etc.
Solo Switches	Not pressed (LED off).	All channel and Master Solo switches
Mute Switches	Start with all Mute switches pressed (LED on, muted). After power-up, unmute only those Input or Output channels that are to be used.	Channel Mute switches, Main L-R Mute switches, etc.
Other Switches	Not pressed.	+48V Phantom, Channel Assign switches to Main or Sub 1-2 or Sub 3-4, etc.

BASIC AUDIO CONNECTIONS

The MX-5200 is designed to accept high- and low-level sources via its 1/4" and XLR inputs on each channel. For optimum clarity and to prevent noise from entering the system, use good-quality shielded cables and make sure all connections are tight. Where applicable, use a balanced input or output.

Connecting The MX-5200 To Recording & Sound Reinforcement Gear For Use

For initial setup, test the mixer in the following basic configurations, which give you a feel for connecting the MX-5200 and how the primary inputs and outputs work. Before plugging in or unplugging any of the audio connections or switching power on or off, be sure that the power amp levels are turned all the way down, in order to protect your speakers.

Mains: Connect the Right and Left Main outputs (XLR and 1/4" balanced outputs are provided on the rear panel) to a power amplifier and speakers. Set the Left Main and Right Main faders to their lowest positions ($-\infty$). On Channel 1, press the Main button on the Input Channel and turn the Channel 1 Pan control to its midpoint (12 o'clock).

Connect a microphone or other sound source to one of the inputs on Input Channel 1, and make sure that no Solo and Mute buttons are pressed. Move the Fader to the 0dB position, and set the Trim knob to its full counterclockwise (Min) position. While talking into the microphone or while another sound source is providing sound, turn up the Trim control until the Peak LED lights, and then back off the gain control until the Peak LED on the Input Channel no longer glows constantly. Turn up the power amplifier's level controls and then slowly raise the Left Main and Right Main faders. You should hear sound from the speakers, and the Left and Right meters should track the output of the Left Main and Right Main (provided that no Solo switch is "on" anywhere on the console, thus switching the meters from the L/R Main to whatever signal is "soloed").

Control Room & Headphones: Connect the Control Room outputs (1/4" left and right phone jacks) to a power amp and speakers. Set the Control Room and Headphones levels to their full counterclockwise position ($-\infty$). As in the previous example, press the Main button on the Input Channel and turn the Pan control to its midpoint. Make sure that the 2 Track Playback and Mono switches in the Control Room portion of the Master Module Section are not pressed.

Connect a microphone or other sound source to one of the inputs on Input Channel 1, and make sure that no Solo and Mute buttons are pressed (their LEDs should not be glowing). Move the channel Fader to the 0dB position and set the Trim knob to its full counterclockwise (Min) position. While talking into the microphone or while another sound source is providing sound, turn up the Trim control until the Peak LED lights. Then back off the gain until the Peak LED on the Input Channel is not glowing constantly. Turn up the power amplifier's gain. Now

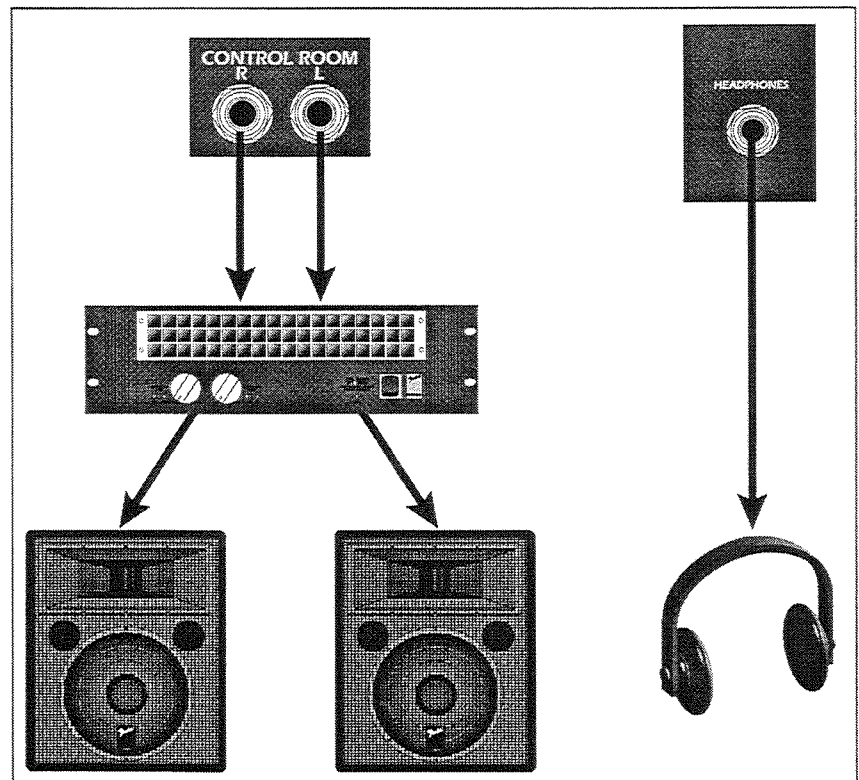
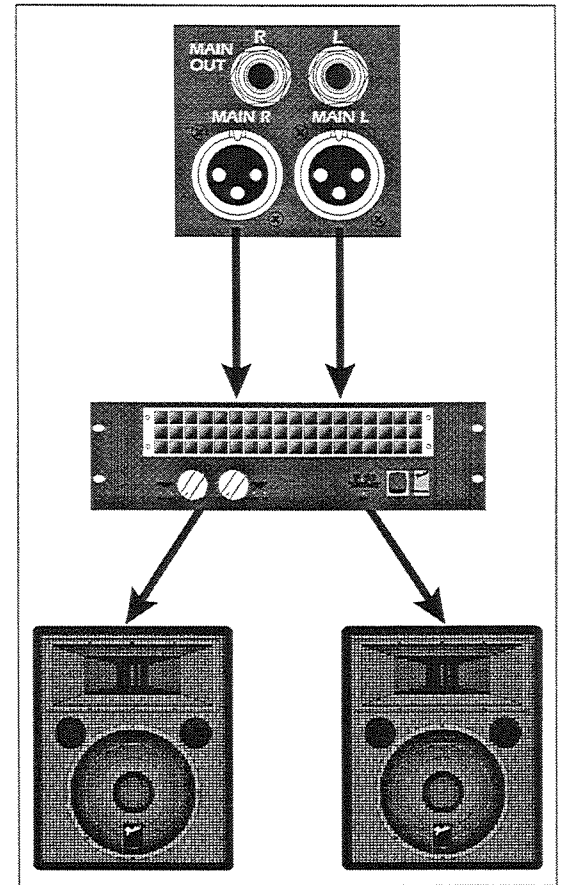

bring up the Left and Right Main faders to their nominal (0dB) position.

Next, slowly turn the Control Room Level knob clockwise, raising its gain. You should hear sound from the speakers. Plug a set of headphones into the Headphones jack and slowly turn the Headphones Level control clockwise. You should hear sound from the headphones. Now plug the output of a CD player or tape recorder into the two Tape (L/R) phono/RCA jacks on the rear panel. Press the 2 Track Playback button in the Control Room section of the Master module. The control room monitor output should now switch from the Main L/R mix to the output of the CD or tape player.

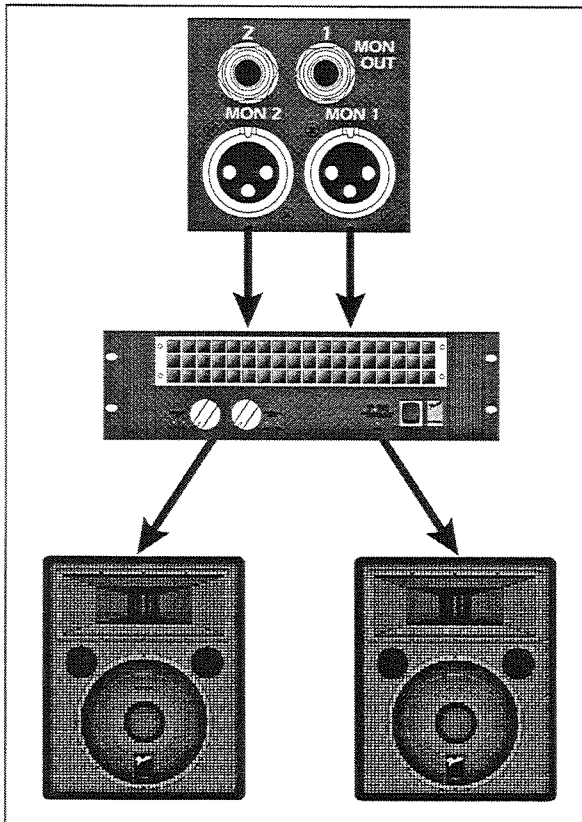

Stage Monitors: Connect the Monitor outputs (XLR or 1/4" balanced outputs on the rear panel of the MX-5200) to a power amplifier and speakers. Set the Stage Monitors 1 Master Level control to its full counterclockwise position ($-\infty$). Make sure that the Mute switch for each of these Stage Monitor outputs is not pressed. Press (select) the Solo switch on Stage Monitor 1 to meter the output level of Stage Monitor mix 1.

Be sure that the Monitor Send switch on Input Channel 1 is set to the "Pre" position. Connect a microphone or other sound source to one of the inputs on Input Channel 1, and make sure that the Channel 1 Solo and Mute buttons are not pressed (their LEDs should not be glowing). Set the Trim knob to its full counterclockwise (Min) position. The Channel 1 fader should be all the way down ($-\infty$). Set the Monitor 1 level on the Input Channel to its midpoint (12 o'clock position). While talking into the microphone or while another sound source is providing a signal, turn the Trim control until the Peak LED flashes; then back off until it only occasionally lights. Turn up the power amplifier's gain and then slowly turn the Stage Monitors 1 level control clockwise. You should hear sound from the speakers, and the meters on the left side of the console should operate. If they do not, check to see that the Solo Level control is all the way up, which will give you a true AFL meter reading. Since the Send is pre-channel fader, the position of the fader should have no effect (the Send will work even if the fader is all the way off). Try switching the Channel 1 Mon. Send to post-fader using the switch. If the fader is all the way off, the signal should disappear. Try bringing up the fader: As you increase the fader's gain, the Send Level should track it. If this works, try using Monitor Send 2 the same way. Be sure to turn off the Mon. 1 Solo switch.

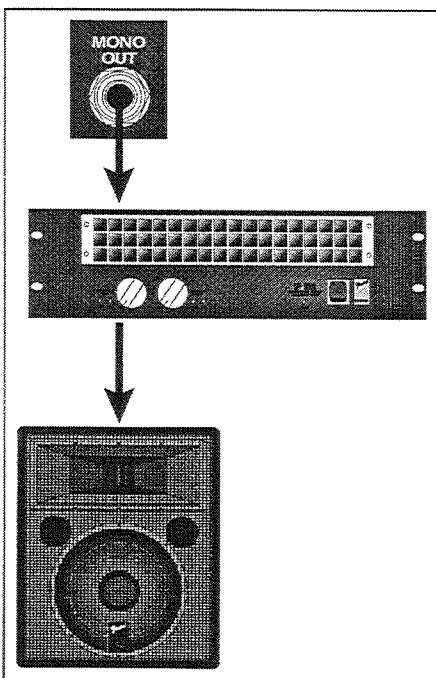

Mono: Connect the Mono Out 1/4" jack to a power amp and speaker(s). Set the Left Main and Right Main faders to their lowest positions ($-\infty$) and the Mono Level to its fully counterclockwise ($-\infty$) position.

Assign Input Channel 1 to the Left and Right Mains, and center the pan pot on Channel 1 so it feeds both channels. Connect a CD player or other sound source to one of the inputs on Input Channel 1, and make sure that no Solo and Mute buttons are pressed anywhere on the console (their LEDs should not be glowing). Set the Trim knob to its full counterclockwise (Min) position. While the sound source is providing sound, turn the Trim control until the Peak LED lights; then back off slightly. Now move the fader to the 0dB position. Next, bring up the Left Main Master fader until the Left meter reads 0dB. Press the Solo button on the Mono (sum) output, making sure that the Solo Level control is all the way up: so as to give the meters a true AFL reading. Turn up the power amplifier's gain and then slowly raise the Mono (sum Master) Level control. You should hear sound from the speaker(s). Bring up the Mono Level control until it reads 0dB. Release the Mono Solo switch, and then bring up the right Main Master fader until the left and right meters read 0dB. Now, press the Mono Sum Solo button again. The left meter should now be +3dB higher than 0dB. This is caused by combining the Left and Right Main mix into mono.

Submasters: Connect Submaster 1's output to a power amplifier and speakers. Set the Submaster 1, 2, 3, and 4 faders to their lowest positions ($-\infty$) and the Submaster Pan controls to their midpoint (12 o'clock position). Make sure that the Solo, Mute, and Main buttons in the Submaster section are not pressed. Press the Sub 1-2 button on Input Channel 2 and turn the Pan control to its midpoint.

Connect a microphone or other sound source to one of the inputs on Input Channel 1, and make sure that no Solo and Mute buttons are pressed (their LEDs should not be glowing). Set the Trim knob to its full counterclockwise (Min) position. While talking into the microphone or while another sound source is providing a signal, turn the Trim control until the Channel 1 Peak LED lights; then back off the gain until the Peak LED on the Input Channel is not glowing constantly. Move the Fader to the 0dB position. Turn up the power amplifier's gain and then slowly raise Submaster 1's fader. You should hear sound from the speakers. Press the Submaster 1 Solo button, making sure that the Solo Level is all the way up, and the Enable Stereo In Place Solo button is not pushed. You should now see the left meter reading the output of Submaster 1. Now deselect the Submaster 1 Solo. Make sure no other Solo buttons are pushed (if they're pushed, then their LEDs will glow). Press the Main/Sub 1 switch in Submaster 1, assigning Submaster 1 to the Left and Right Mains. With the pan pot centered on Submaster 1, as you bring up the Submaster 1 level, the signal should appear on the left and right meters, showing a signal on the Left and Right Main bus. (Try plugging the input to your power amp into either the Left or Right Main output to confirm this.) Now turn the pan control, and the signal should swing from left to right. Try the other submasters as well, using the assignment switches and pan pot on Channel 1 to route the signal to the other submaster buses.

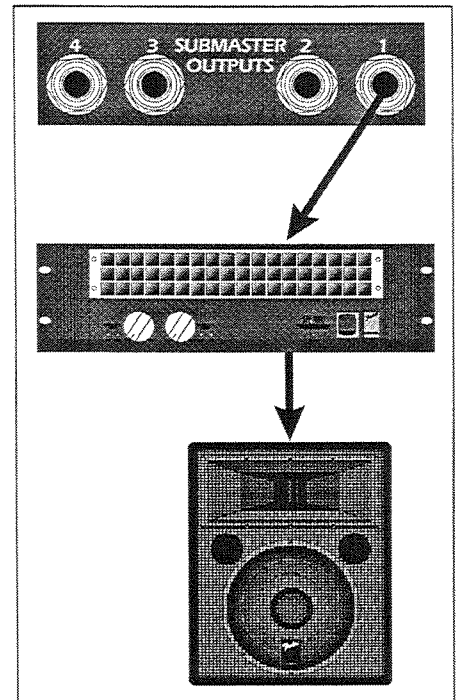

Auxiliaries: Connect two of the four Auxiliary Outputs to a power amplifier and speakers (start with Auxiliary Outputs 1 and 2, and repeat the procedure later for Auxiliary Outputs 3 and 4). Set the Auxiliary 1, 2, 3, and 4 Levels to their full counterclockwise positions ($-\infty$). Make sure the Auxiliary selector button (labeled 1-2 and 3-4) on Channel 1 is not pressed, thus assigning the sends to Aux 1/2. (When you repeat the procedure for Auxiliary Outputs 3 and 4, press the 1-2/3-4 button, thus reassigning the sends to Aux 3/4.)

Connect a microphone or other sound source to one of the inputs on Input Channel 1, and make sure that no Solo and Mute buttons are pressed anywhere on the console (their LEDs should not be glowing). Set the Trim knob to its full counterclockwise (Min) position. While talking into the microphone or while another sound source is providing a signal, turn the Trim control until the Peak LED lights; then back off the gain until the Peak LED on the Input Channel is not glowing constantly. Move the fader to the 0dB position. Press the Solo button on Aux. 1, making sure that the Solo Level is all the way up, and the Enable Stereo In Place Solo button is not pushed, so as to give a true meter reading on the output of Aux. 1. Turn up the power amplifier's gain and then slowly turn the Auxiliary 1 Master Level control clockwise. You should hear sound from the left speaker, and the level on the left meter should track the output level of Aux. 1. Now try Aux. Send 2 the same way (the sound should come out of the right speaker). Then try Aux. 3 and Aux. 4 the same way.

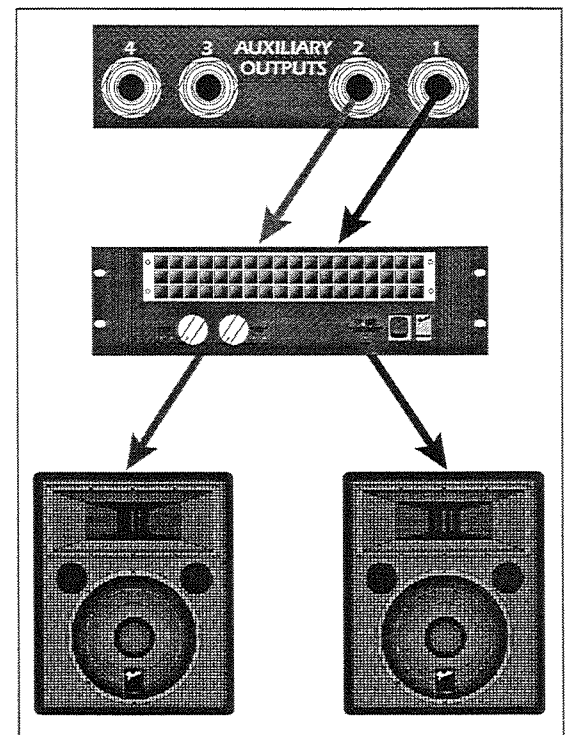

For Further Connection Information

There are certainly many other connection possibilities with the MX-5200, including the inserts, returns, tape inputs, etc. Details on using them are included in this manual in their respective sections.

BLOCK DIAGRAM OF MX-5200 SERIES MIXER

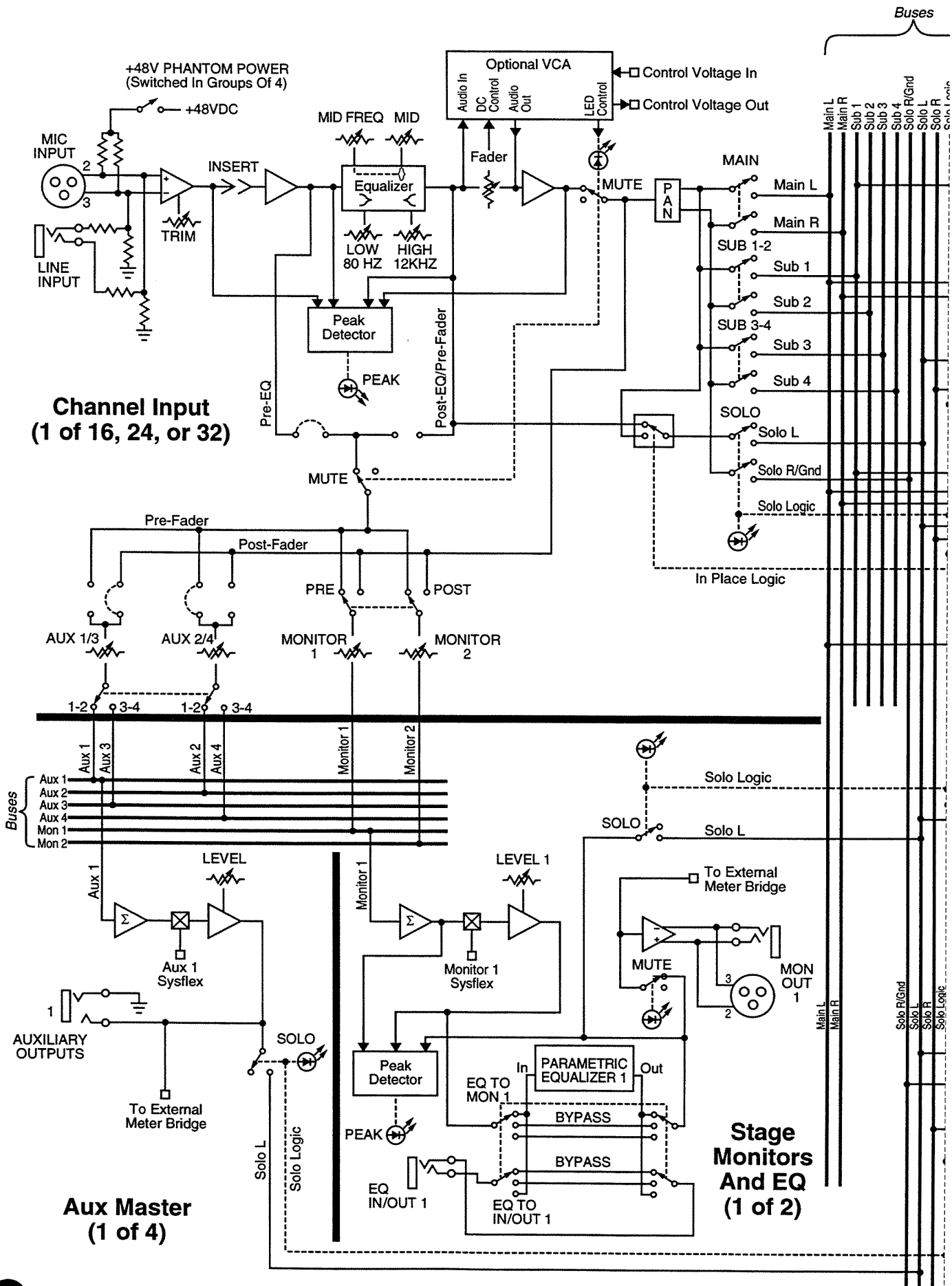



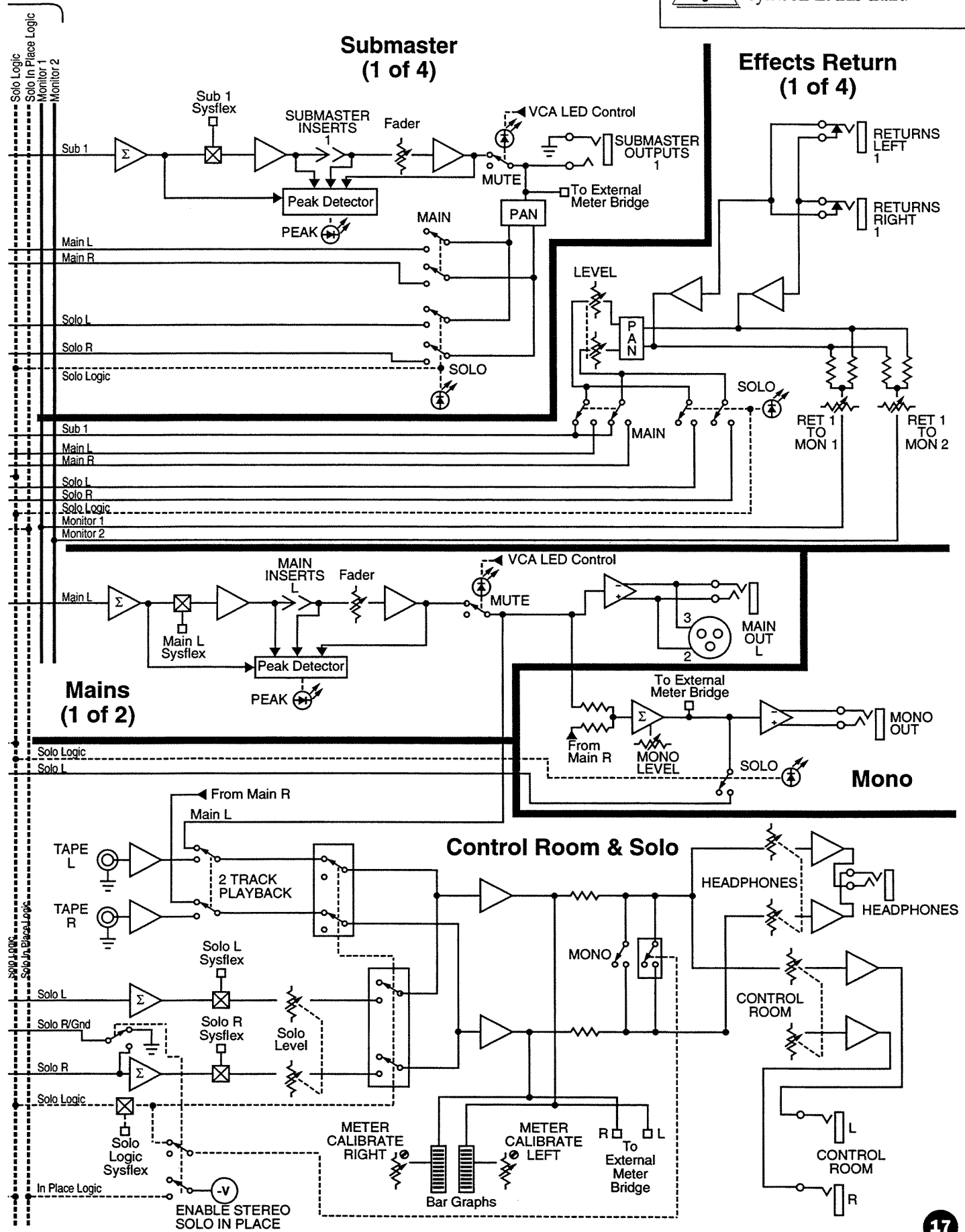























See legend on page 18 for an explanation of the symbols in this chart.



Block Diagram For MX-5200 Series Mixers

The block diagram on pages 16 and 17 shows how the signals travel throughout the MX-5200, without the minute detail usually associated with full electronic schematic diagrams. Notice that wherever multiple channels of one kind are included on the MX-5200, only one of those channels is shown in the block diagram. This simplifies following the signals. (If you need them, full schematic diagrams have been included separately.)

Legend For MX-5200 Series Mixer Block Diagram

	Border between mixer sections		Amplifier
	Arrow indicates signal flow direction		Summing amplifier
	Bus		Amplifier with balanced output
	Signal line		TS (Tip/Sleeve) jack
	Logic line		TRS (Tip/Ring/Sleeve) jack
	Insert point		XLR input or output jack
	Wires intersect, but do not connect		RCA (phono) jack
	Wires intersect and connect		Sysflex™ connecting point
	Internal jumper		External connection for VCA or Sysflex control
	Switch		Ground
	Logic-controlled switch		LED
	Ganged switches operating in tandem		Bar graph meter display
	Pot, fader, etc.	LEVEL	Capitalized type indicates panel control
	Trim pot	Mono	Large, boldface type indicates a module on the MX-5200 Series mixer
	Ganged pots operating in tandem		

CHANNEL INPUT SECTION

The channel input section consists of multiple input modules, with each input module providing eight Input Channels. The MX-5216 has two input modules for 16 inputs, the MX-5224 has three input modules for 24 inputs, and the MX-5232 has four input modules for 32 inputs.

Each Input Channel is outfitted with a rear-panel line-level input (1/4" tip/ring/sleeve, balanced or unbalanced), a rear-panel mic-level input (XLR, balanced), a studio-grade microphone preamplifier, and a rear-panel 1/4" TRS Insert jack (tip=send/ring=return). Switchable 48-volt Phantom Power is designed to provide internal power to the XLR Mic inputs in groups of four Input Channels at a time (1-4, 5-8, etc.).

The Trim control sets the level of the signal passing through the mic preamp, and the EQ section (shelving low and high, sweepable midrange) shapes the sound. Two knobs provide the Auxiliary sends to Aux Buses 1 through 4, and two knobs provide the Stage Monitor mixes (which are selectable for pre- and post-fader monitoring). Each input may be assigned to the stereo Main mix (Left and Right) and four subgroups by pressing the appropriate assignment switch, as well as operating the pan pot. (Buses are the connecting points where various inputs, outputs, or circuits connect or derive signal.) The Solo switch is provided for Headphone and Control Room monitoring, as well as metering, and the Mute switch turns the channel on and off. A Peak Detector circuit with LED indicator monitors signal levels before and after the Insert point, after the EQ section, and after the fader, immediately letting you know if an overload condition occurs in the critical first stages of the signal path. Finally, a long-throw fader offers precise control over level.

Each channel in the Input Section is identical to the others, so all functions outlined in the following chapter are applicable to every Input Channel.

+48V Phantom Power

This switch is found in each group of four Input Channels (1-4, 5-8, 9-12, etc.). When it is on, +48 volts DC is delivered to pins 2 and 3 on each of the four XLR connectors in the group of four Mic inputs. This is suitable for powering condenser microphones or active direct boxes requiring phantom power.

Note: In most cases, microphones not requiring phantom powering can be plugged into any input in a group that is receiving phantom power without an effect on their performance. Some gear may not be able to handle phantom power, though, so check with the manufacturer of your other equipment before connecting it to a channel where phantom power is activated.

Trim

The Trim control adjusts the channel's input gain by varying the mic preamp's gain, thereby matching the signal from a mic or other source to the mixer. Its wide range (48dB of gain) allows you to optimize the preamp gain for different sources while minimizing preamplifier hiss and optimizing preamplifier headroom.

EQ Section

Your MX-5200 Series mixer has been designed with a very powerful input equalizer. This equalizer provides two fixed-frequency shelving-type EQ controls (high and low) and a peak/dip type of midrange control section that is sweepable.

High EQ

The High EQ circuit has a fixed center frequency of 12kHz and allows for boosting or cutting by ± 15 dB.

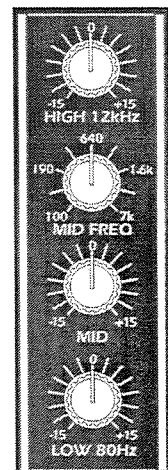
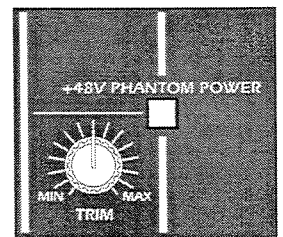
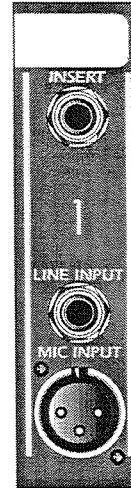

Mid Frequency & Mid (Boost/Cut)

Two controls govern the midrange. The one labeled “Mid Frequency” selects the center frequency from a range of 100 Hz to 7kHz, while the one labeled “Mid” adjusts the amount of boost or cut at that selected center frequency. It allows for boosting or cutting by $\pm 15\text{dB}$.

Low EQ

The Low EQ circuit has a fixed center frequency of 80 Hz and allows for boosting or cutting by $\pm 15\text{dB}$.

Aux Bus Send Controls

Two knobs provide the Aux Sends, and they are switchable as a pair by the 1-2/3-4 switch above the two knobs labeled Aux 1/3 and Aux 2/4 on each Input Channel.

Note: This switch has nothing to do with pre/post selection. The four Aux Sends come wired for pre- and post-fader use. This may be changed by moving internal jumper positions for each Send control.

Here is the standard MX-5200 Auxiliary Bus configuration:

- Aux 1/3 routes the post-EQ/post-fader signal to Auxiliary Buses 1 or 3.
- Aux 2/4 routes the pre-EQ/pre-fader signal to Auxiliary Buses 2 or 4.

Internal jumpers (to be added or changed only by an Authorized Fender Service Center) allow this configuration to be changed to the following:

- Post-EQ/post-fader or post-EQ/pre-fader on all Aux Sends (1 through 4).
- Pre- or post-fader on all Aux Sends (1 through 4).

In addition, when the channel Mute switch is engaged, the post-EQ/post-fader signal is muted, but the pre-EQ/pre-fader signal is not. This allows signals to be sent to effects even as a channel’s level (fader) is being decreased; this is useful, for example, when you want to create the illusion of increasing distance, by increasing reverb while decreasing the direct signal. It also allows a channel to be “cued” in the PFL solo system, even if the channel is muted.

Stage Monitor Send Section

The two Stage Monitor send controls for each Input Channel allow for selection of pre- or post-fader sends for onstage monitoring. The level of the signal being sent to each monitor bus can be separately adjusted by the two send controls (Monitor 1 and Monitor 2). Both sends can be selected pre- or post-fader by a single switch.

Here is the standard configuration for the monitor sends:

- Pre-EQ/pre-fader or post-EQ/post-fader to Monitor 1 and Monitor 2, switch-selectable.

Internal jumpers (to be added or changed only by an Authorized Fender Service Center) allow this configuration to be changed to the following:

- Post-EQ/pre-fader or post-EQ/post fader signal to Monitor 1 and Monitor 2.

Note: Changing the internal jumper positions must be performed by a qualified service technician. Consult your Fender Electronics dealer for details.

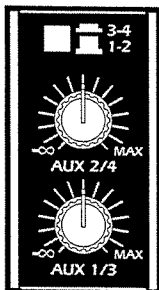

Submaster/Fader Bus Assignment Section

After the signal has been processed by the Input Channel's mic preamp, EQ, and fader, it is sent to the Pan control, which adjusts the position of the signal on each pair of buses that are selected by the assignment switches (like a motion picture camera pans from left to right).

When they're pressed, the assignment switches route the stereo output of the pan pot in the following manner:

Switch	Grouping
Main	Main L and Main R
Sub 1-2	Submaster 1 and 2
Sub 3-4	Submaster 3 and 4

Any combination of the three switches can be selected, providing up to three stereo pairings or six individual bus routings.

Solo/Mute Section

Each channel has a Solo switch and a Mute switch, enabling you to audition only that channel (Solo) and to turn the channel off to reduce noise or to block unwanted audio sources from entering the mix (Mute). The Solo and Mute switches are accompanied by LEDs that indicate when the channel's Solo or Mute function is active.

Mute Switch

When the Mute switch on an Input Channel is pressed, signal from that Input Channel is turned off—or muted—to the Main, Submaster, Auxiliary, and Monitor Buses (if post-fader is selected). If the Enable Stereo In Place Solo button is switched in, a channel is soloed, and then if the Mute button on that channel is pressed, the signal to the Solo Buses will also be muted. Pressing the Mute switch causes the red Mute LED to glow, showing that the channel has been turned off.

Solo Switch

The Solo button on each Input Channel operates in two different ways, depending on the Enable Stereo In Place Solo button in the Master section. Note that the Enable Stereo In Place Solo button's setting (in or out) has no effect on anything in the MX-5200 until a Solo button is pressed. Note, too, that Soloing on the MX-5200 is non-destructive; that is, soloed signals are sent only to the meters and to the Control Room and Headphone outputs, leaving all other console outputs unaffected.

PFL Solo Mode

When the Enable Stereo In Place Solo button is in its "out" position (disabled) and the Input Channel's Solo button is pressed, the pre-fader/post-EQ signal (pre-fader listen, or PFL) is routed in mono to both the left and right control room and headphone outputs. Simultaneously, the left meter monitors its level. A PFL Solo is extremely handy for troubleshooting in live P.A. settings (it's sometimes referred to as a cue switch) because it allows you to see if a channel has signal—by using the meters—and to isolate or identify a problem and fix it, even if the channel is muted.

Stereo In Place Solo Mode

When the Enable Stereo In Place Solo button is in its "in" (enabled) position and the Input Channel's Solo button is pressed, the Stereo In Place Solo mode is activated. In this mode, the post-fader/post-Mute/post-Pan stereo signal that is fed to the assignment switches' inputs is also sent to both the Left and Right Control Room and Headphone outputs in stereo. The left and right meters indicate the levels of this soloed, stereo channel. This allows you to isolate an input or group of inputs in a complicated stereo mix, allowing you to precisely place it "in position" using the fader, pan controls, and (when used) effects/auxiliary sends and returns. This is very helpful in a recording studio, where placement of instruments and effects in the stereo mix are critical.

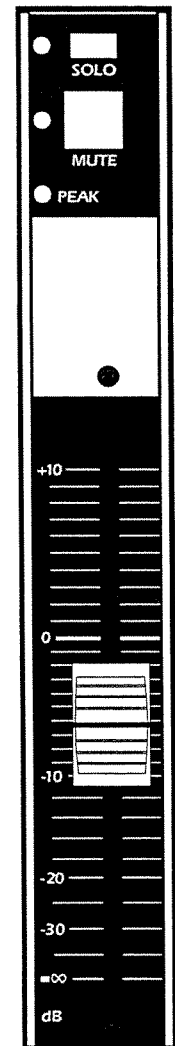
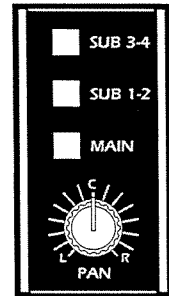

Solo/Mute Section, continued

Note: When Enable Stereo In Place Solo mode is enabled, if the Solo button is pressed while the channel's Mute is active, no signal from the channel reaches the control room or headphone outputs.

Quick Solo & Mute Reference

Details on each Solo and Mute switch's function are included in their corresponding sections in this manual. However, as a quick reference, here is a condensed guide to their basic functions.

Note: The Solo functions only affect the Control Room, Meter, and Headphones outputs. Some Mute functions affect the Control Room and Headphones outputs and/or the other outputs.

SOLO FUNCTIONS

Where Solo Switch Is Located	Enable Stereo In Place Solo Switch	Type Of Solo	Signal Obtained From	Solo Sent To	Meter Reading
Input Channel	Disabled	PFL (mono)	Pre-fader/ Post-EQ	Mono to both L & R Outputs	On L only
	Enabled	In Place Stereo	Post-EQ Post-fader/ Post-Mute/ Post-Pan	L & R Outputs	On L&R
Submaster 1-4	Disabled	AFL (after Submaster fader listen)	Post-Submaster fader	Mono to L & R Outputs	On L only
	Enabled	PFL Summed to mono	Post-Submaster fader/ Post-Mute Post-Pan	L & R Outputs	On L&R
Returns 1-4	Disabled	In Place Stereo	Pre-fader	Summed to mono, then to L & R Outputs	On L only
	Enabled	In Place Stereo	Post-Level Post-Pan	L & R Outputs	On L&R
Mono	Disabled	AFL mono	Post-fader	Mono to L & R	On L only
	Enabled	AFL mono L	Post-fader	L Output only	On L only
Monitor 1-2	Disabled	AFL mono	Post-fader/ pre-Mute	Mono to L & R	On L only
	Enabled	AFL mono L	Post-fader/ pre-Mute	L Output only	On L only
Aux 1-4	Disabled	AFL mono	Post-fader	Mono to L & R	On L only
	Enabled	AFL mono L	Post-fader	L Output only	On L only

Note: PFL means pre-fader listen; AFL means after-fader listen.

MUTE FUNCTIONS

Where Mute Switch Is Located	What Is Muted When Switch Is Pressed
Input Channel	Post-EQ/post-fader/post-pan feed to Main L & R, Submaster 1-4, Aux 1-4, Mon 1 & 2, Stereo In Place Solo L & R (not PFL), Control Room, and Headphones
Submaster 1-4	Submaster output, post-pan feed to Main L & R outputs (if assigned to Main L/R mix), and Solo L & R outputs (in Stereo In Place Solo mode)
Left Main	Left Main outputs, Left Main feed to Mono Sum Out, Control Room Left output (assuming 2 Track Playback switch is not engaged), and Headphone Left output, assuming nothing is soloed
Right Main	Right Main outputs, Right Main feed to Mono Sum Out, Control Room Right output (assuming 2 Track Playback switch is not engaged), and Headphone Right output, assuming nothing is soloed
Stage Monitors 1-2	Stage Monitor 1 & 2 outputs

Peak LED

The Peak LED on each Input Channel monitors signal levels before and after the Insert point, after the EQ section, and after the Fader. The Peak LED glows when signal levels exceed 6dB below the clipping point. This gives you plenty of warning that the signal may be reaching levels at which distortion may be introduced. It's okay to have the LED blinking on occasion, but if it glows continuously, then the level is too high. As always, use your ears in addition to what you see in the Peak LED and meters to help guide you.

Channel Fader

Each Input Channel has a long-throw (100mm) fader that is designed for precise adjustment of the channel's level. Its circuitry is designed so that signal levels are smoothly adjustable whether the fader is at the top or bottom of its range, so that there are no "dead zones," or abrupt changes.

INPUT CHANNEL REAR-PANEL JACKS

Each Input Channel is equipped with three rear-panel jacks: Mic Input (XLR), Line Input (1/4" tip/ring/sleeve, or TRS), and Insert (1/4" TRS).

Mic Input

The Mic Input is a female XLR jack designed to accept balanced signals from microphones, direct boxes, or other low-level gear. Phantom power (when switched on) is available on pins 2 and 3. The audio "+" signal is carried on pin 2, while the audio "-" signal is carried on pin 3.

Line Input

The Line Input is a 1/4" input designed to accept balanced or unbalanced line-level signals from CD players, recorders, signal processors, high-level keyboards and other instruments, etc. The tip carries the audio "+" signal, the ring carries the audio "-" signal, and the sleeve is grounded.

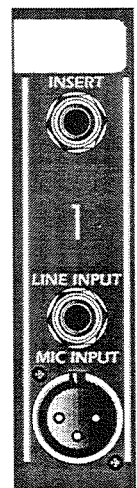

Input Channel Rear-Panel Jacks, continued

Both inputs connect to the input-stage preamplifier, and are mixed together (there is no provision for adjusting their mix if both inputs are used, except by adjusting the gain at the sources). The inputs' gain is adjusted by the trim control. The line input will be attenuated -20dB below the mic input.

Insert Jack

The Insert point is a 1/4" TRS stereo jack with a normally closed switch. This jack acts as both a send and a return for patching external processors into the signal path (between the channel's input preamp and the EQ stage) and may also be used as a direct output. The jack's tip is the send and the ring acts as its return.

When no plug is inserted into the jack, the Send and Return are "normalled" together (that is, they are connected automatically), so the signal flows directly from the input preamp to subsequent sections.

Inserting a plug either halfway or fully into the jack breaks the "normal" between the Send and Return. When inserting external signal-processing devices into an Input Channel, a high-quality patch cable with a single 1/4" TRS plug at one end and two mono 1/4" plugs at the ends of the two cords connected to it (or 1/4" TRS plug to two phono plugs) is recommended. It should be wired as shown in these diagrams:

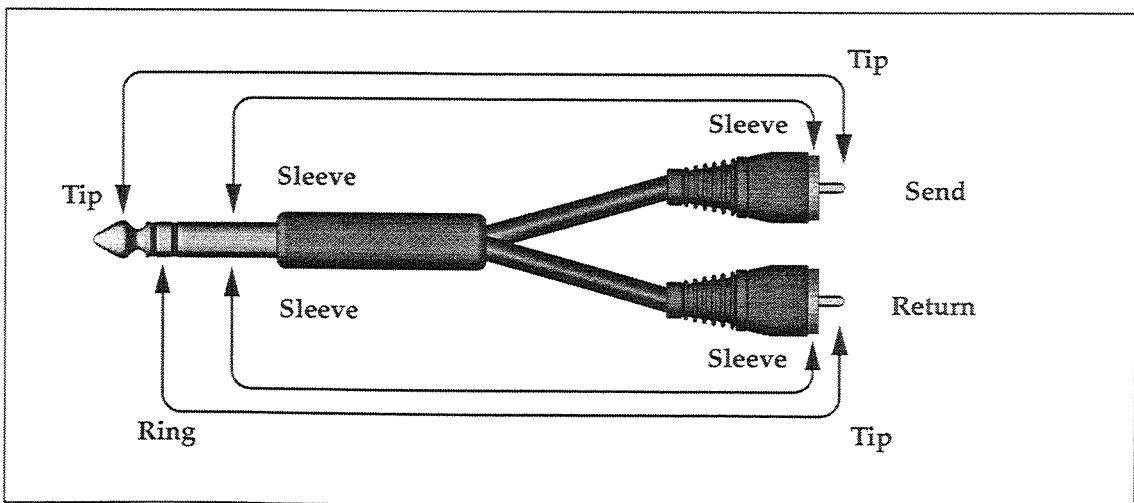
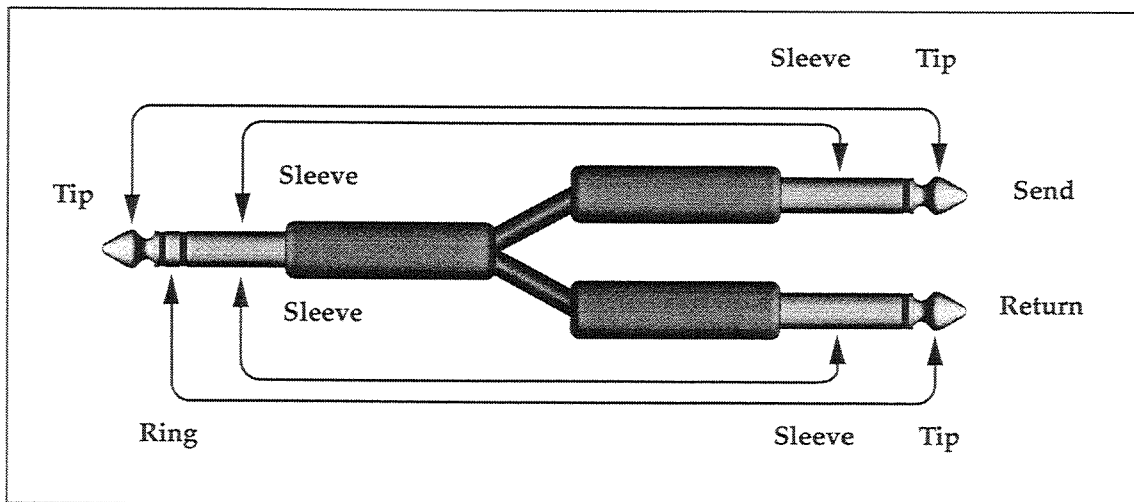

The Insert jack can also be used as a pre-EQ/pre-fader direct output. In order to take a direct output from each channel without breaking the normal signal flow (for example, to record direct to a multi-track recorder during live performance), a special adapter cable wired with the following connections must be made:

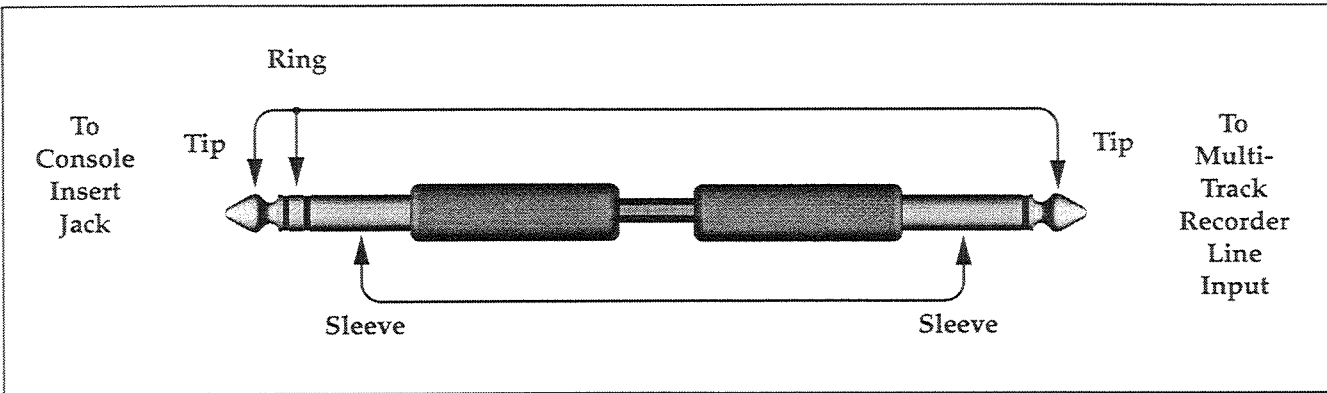

A standard stereo cord equipped with 1/4" TRS plugs on both ends can be used to patch either of the MX-5200's Parametric Equalizers into a channel's signal path for ultra-precise equalization. (See the section on the Parametric Equalizer below.) The following diagram shows the correct wiring for the Parametric EQ insertion cable:

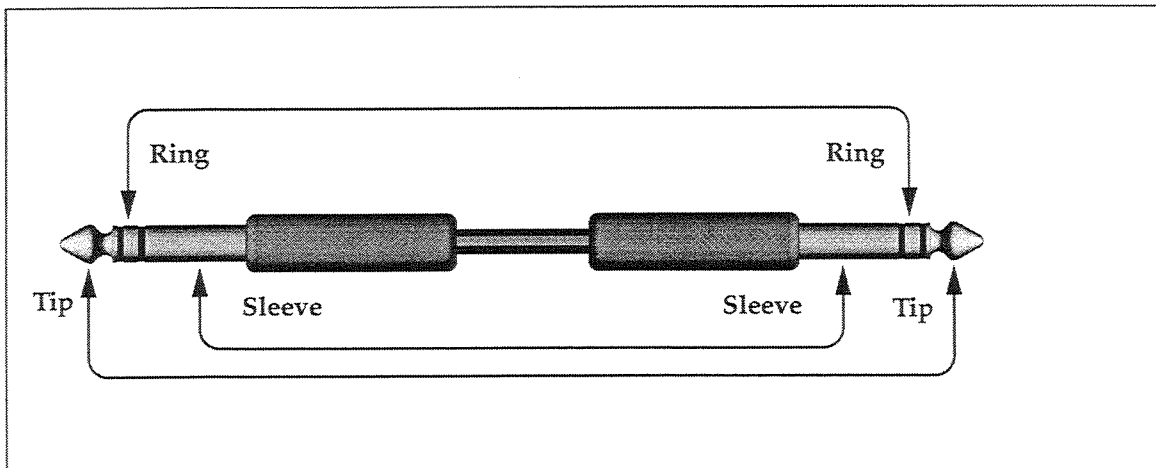

MASTER MODULE SECTION

Parametric Equalizer Section

Two extremely versatile "outboard" parametric equalizers are built into the MX-5200, providing you with the ability to (1) create two inputs with very flexible EQ, (2) equalize the main stereo mix, (3) group several inputs together and equalize the entire subgroup, or (4) control feedback in the stage monitors. This is accomplished by switching the two equalizers into the Monitor 1 and Monitor 2 outputs, or by patching the equalizers' EQ In/Out jacks into any of the MX-5200's insert jacks (on any Input Channel, Submaster, or Master) via a standard TRS stereo cable. The equalizers' send/return jacks are wired the opposite of the rest of the MX-5200's insert jacks specifically for this purpose, so the insert send matches the EQ input, and the EQ output matches the insert return. Regardless of whether you use the switchable internal connection between the equalizers and the monitor mixes or patch into the inserts, either can be bypassed with the 3-position slide switch (Bypass is the center position), for EQ/non-EQ comparison, or simply to defeat the equalizer. Note that both equalizers have identical features. The difference is that the first position on Parametric Equalizer One's 3-way selector is hardwired to the Monitor 1 bus, and the first position on Parametric Equalizer Two's 3-way switch is hardwired to the Monitor 2 bus.

Each parametric equalizer can be used to tame unwanted resonances (such as feedback), boost anemic frequencies, or add clarity or punch to sounds. In addition, the low-cut and high-cut roll-off filters let you remove subsonic and supersonic sounds that can create intermodulation distortion or subwoofer-unfriendly rumbling, and can also be used to “band-limit” the range of frequencies reproduced. This can be extremely helpful in both live and studio applications, and is a vast improvement over a simple lowpass filter switch.

EQ To Mon 1 • Bypass • EQ To In/Out 1 Switch

This 3-position switch selects the routing of the input and output signal for the Parametric Equalizer. In its EQ To Mon 1 setting, it inserts the equalizer between the monitor mix and the monitor outputs. It is placed after the Stage Monitor Level control and before the Stage Monitor Mute switch.

The 3-way switch’s center position—Bypass—provides a hardwired bypass of the Parametric Equalizer. It also acts as a bypass if you are using the Parametric Equalizer’s EQ In/Out jack to patch the EQ into an insert.

The 3-way switch’s right position inserts the Parametric Equalizer into the signal path of whatever insert patch point (Input, Submaster, or Main) is plugged into the rear-panel EQ In/Out jack.

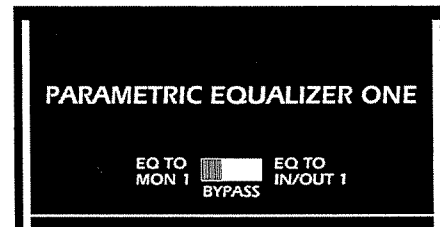

High-Mid Frequencies

The three knobs and one switch in the High-Mid Frequencies parametric EQ band act together to select the center frequency (the frequency the EQ operates from), range (also known as slope, or bandwidth, and sometimes mistakenly called “Q”) of the High-Mid band’s operation, and the amplitude (amount of boost or cut) that occurs in this band.

Cut/Boost Control

This knob adjusts the amount of boosting or cutting of the selected frequency band. It can boost or cut by 15dB, and its straight-up (12 o’clock) position is 0dB, where there’s no boosting or cutting.

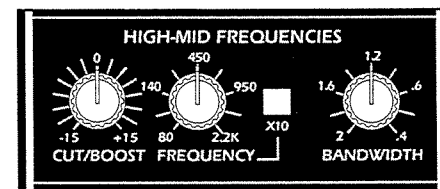

Frequency Control And Frequency Multiplier (x10) Switch

The High-Mid band’s center frequency is sweepable over a range of 80 Hz to 22kHz. With the x10 switch in the “out” position (not engaged), the range is 80 Hz to 2.2kHz. Pushing in the frequency multiplier switch (engaging it) increases that range by a factor of 10, thereby changing it to a range of 800 Hz to 22kHz.

Bandwidth Control

The Bandwidth control sets how narrow or wide a range around the frequency center is affected by the equalizer. The range is expressed in octaves (.4 octaves to 2 octaves), rather than specific frequencies, since the range is a ratio that changes with frequency. (An octave is the difference between one frequency and another that is twice that frequency—for example 350 Hz and 700 Hz, or 60 Hz and 120 Hz).

Note that the bandwidth covered by an octave at one frequency is different from the bandwidth of an octave at another frequency. For example, at 1kHz (1,000 Hz), a bandwidth of .4 octaves is 400 Hz. At 100 Hz, that would be 40 Hz. At 20kHz—approximately the top limit of human hearing—a bandwidth of .4 octaves translates to 8kHz. Narrow bandwidths are excellent for selectively chopping out feedback frequencies, 60 Hz hum, etc. Broader bandwidths mean that the equalizer affects a wider range of frequencies.

Low-Mid Frequency Band

The three knobs and one switch in the Low-Mid Frequencies EQ band act together to select the frequency center, range (bandwidth) of the band’s operation, and the amplitude, or the amount of the boost or cut.

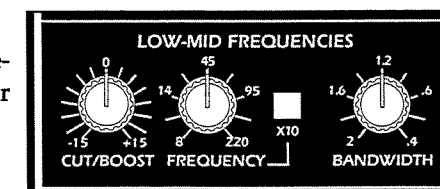

Cut/Boost Control

This knob adjusts the amount of boosting or cutting of the selected frequency band. It can boost or cut by 15dB, and its straight-up (12 o'clock) position is 0dB, which is no boosting or cutting.

Frequency Control And Frequency Multiplier (x10) Switch

The Low-Mid Band's center frequency is sweepable over a range of 8 Hz to 2.2kHz. With the x10 switch in the "out" position (disengaged), the range is 8 Hz to 220 Hz. Pushing the frequency multiplier switch multiplies that range by 10, thereby changing it to a range of 80 Hz to 2.2kHz.

Bandwidth Control

The Bandwidth control sets how narrow or wide a range around the frequency center is affected by the filter. Like the High-Mid band, the range (.4 octaves to 2 octaves) is expressed in octaves, rather than specific frequencies.

Low Cut

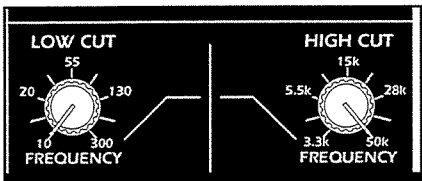

The Low Cut filter is a sweepable highpass rolloff filter with a slope of -12dB per octave. The Low Cut control is variable from 10 Hz to 300 Hz, making it ideal for removing rumble, muddy low frequencies, and subsonic (below 20 Hz) frequencies. The selected frequency is the point where the rolloff begins, extending down in frequency at a slope of 12dB per octave.

High Cut

The High Cut filter is a sweepable lowpass rolloff filter with a slope of -12dB per octave, with an adjustable cutoff frequency. The High Cut control is variable from 3.3kHz to 50kHz. It can be applied to many tasks, including removing cymbal "splash," high-frequency noise (or hiss), or supersonic (above 20kHz) frequencies that may interact with lower frequencies to cause intermodulation distortion.

Power Indicator LED

The LED labeled Power illuminates when the CPSM-4 power supply is connected to the MX-5200 and its power switch is turned on.

BNC Connectors For Console Illumination

At the extreme left and right sides of the MX-5200 are BNC (bayonet-style) connectors designed to hold and provide power for gooseneck-style lamps. The CPSM-4 power supply delivers 12 volts DC to drive them. When using gooseneck lamps, make sure that they are securely connected by turning them until they lock into place. Follow all safety precautions outlined for the power supply on page 39, and never insert anything except a gooseneck lamp's base into the BNC connectors.

Headphones Jack

The 1/4" Headphones jack on the lower right side of the MX-5200's face is designed to provide a high-quality, high-power signal to the headphones. The stereo signal sent to the headphone amplifier is the same as that reaching the control room outputs (that is, if the Control Room is monitoring the stereo main mix, any soloed signal, or the 2-Track Playback source, or if it is in mono or stereo mode), although its level is independently adjustable via the Headphone Level knob in the Master section.



Return Section (1-4)

Four Return channels are identical, with the exception of their bus assignments: Return 1 can be routed to the Left Main and Right Main or Submaster 1; Return 2 can be routed to the Left Main and Right Main or Submaster 2; Return 3 can be routed to the Left Main and Right Main or Submaster 3; and Return 4 can be routed to the Left Main and Right Main or Submaster 4. When the Main/Sub switch for any of the Returns is in the Sub (“out”) position, the signal is sent in mono to its Submaster.

Pan Control, Level Control, And Main/Sub 1 (2, 3, or 4) Selector Switch

If an effects device with a mono output is used, and its output is plugged into only one of the Return jacks, then a mono signal is sent to the Pan control, which sends its stereo output to the Level control. If a stereo effects device with two outputs is used, and those outputs are plugged into both of the return jacks (Return Left and Return Right), then the Pan acts as a stereo balance control, swinging the stereo signal towards the left or right of the main mix, and this stereo signal is then sent to the stereo Level control. From there, the signal goes to the assignment switch, which then routes it to the Left and Right Main, or combines the stereo signal into mono before sending it on to the Submaster corresponding to its Return number (1-4), depending on whether the Main/Sub switch is pressed.

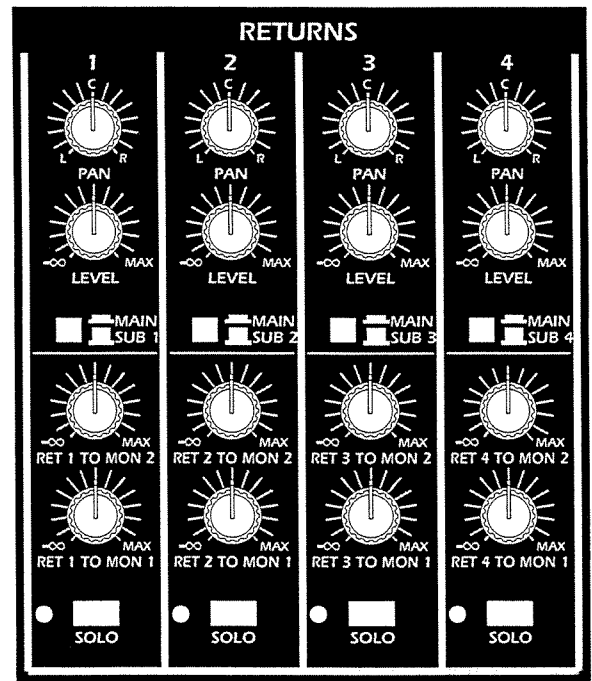

Level Control

The Return Level is a control that adjusts the Return’s gain, regardless of whether both the Left and Right Return inputs are used (stereo returns), or only one of them is employed (a mono return).

Ret 1 (2, 3, or 4) To Mon 1 (Stage Monitor Mix 1) Level Control

The Left and Right Returns come directly from their inputs and are combined into mono and their level adjusted by this control before being sent to the Monitor 1 bus. Since Mon. Mix 1 will most often be used as a vocalist’s monitor, this allows the performer to hear an effect (normally reverb) in the monitor mix.

Ret 1 (2, 3, or 4) To Mon 2 (Stage Monitor Mix 2) Level Control

The Left and Right Returns come directly from their inputs and are combined into mono and their level adjusted by this control before being sent to the Monitor 2 bus. Again, this allows the musicians to monitor “wet” with effects in the second monitor mix.

Solo Switch

The Solo button on each Return channel operates in two different ways, depending on whether the Enable Stereo In Place Solo button in the Master section is pressed to its “in” position. (For information on the effect of the Solo and Enable Stereo In Place Solo functions, see page 21.) The Solo Level control should be turned all the way up in either mode in order to give a true AFL meter level.

When the Enable Stereo In Place Solo button is in its “out” (disabled) position and a Return’s Solo button is pressed, the signal is pre the Level and Pan controls (PFL), summed to mono, and then sent to both the left and right Control Room and Headphones outputs. The left meter monitors the level of the soloed return signal (assuming the Solo Level control is all the way up). This allows you to set the output level of your effects device for optimum headroom and signal-to-noise ratio, and to “preview” the type of effect you have selected, before returning it to the Mains, the Submasters, or the Stage Monitors.

When the Enable Stereo In Place Solo button is in its “in” (enabled) position and a Return’s Solo button is pressed, the left and right post-pan/post-stereo level control In Place Stereo signals are sent to the left and right Control Room and Headphones outputs in stereo. The left

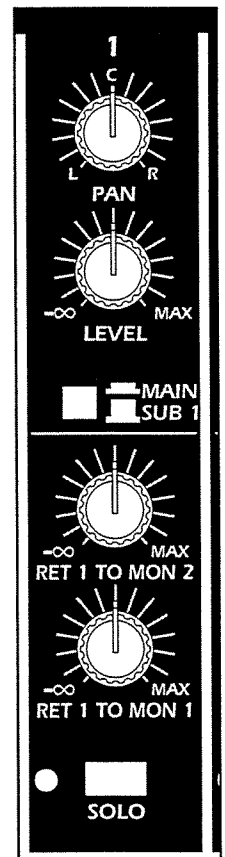

Enable Stereo In Place Solo, continued

and right meters monitor the level of stereo returns' level.

Solo LED indicator

When the Solo switch is engaged (pressed), the LED indicator glows until the Solo switch is pressed again to disengage the function.

Auxiliary Master Level Controls (1-4)

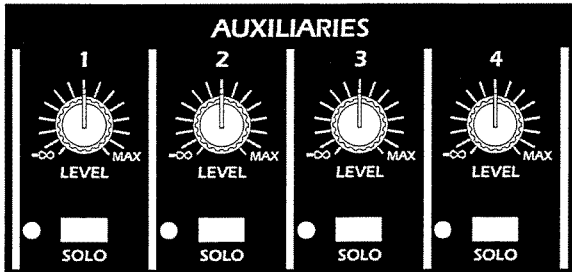

Four Auxiliary outputs provide the flexibility to send the four auxiliary mixes out to external signal-processing equipment (which is then returned to the mix via the Return section), or to additional stage monitor systems, recording gear, etc. Each of the four Auxiliaries in the Master Section contains a Level control and a Solo switch (with LED).

Level Control (1-4)

The Level control adjusts the level of signals on its Auxiliary Bus before sending them to its corresponding Auxiliary Out jack on the MX-5200's rear panel.

Solo Switch

The Solo button on the Auxiliary channels operates in two different ways, depending on whether the Enable Stereo In Place Solo button in the Master section is pressed to its "in" position. (For information on the effect of the Solo and Enable Stereo In Place Solo functions, see page 21.)

When the Enable Stereo In Place Solo button is in its "out" position (disabled) and an Aux's Solo button is pressed, the mono post-fader/pre-Mute (after-fader listen, or AFL) signal is sent to both the left and right control room and headphone outputs. The left meter monitors the signal's level.

When the Enable Stereo In Place Solo button is in its "in" position (enabled) and an Aux's Solo button is pressed, the left channel's mono post-fader/pre-Mute (after-fader listen, or AFL) signal is sent to the left Control Room and Headphones outputs. The left meter monitors the signal's level.

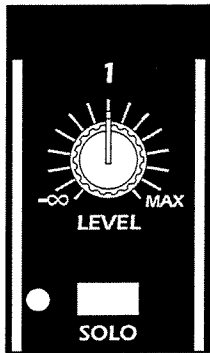

Solo LED Indicator

When the Solo switch is engaged, the LED indicator glows until the Solo switch is pressed again to disengage the function.

Meter Section

The two meters, labeled Left and Right, contain 12-segment LED ladders that keep tabs on levels at various locations throughout the mixer, depending on whether a Solo switch is on. When no Solo switches are on and the 2 Track Playback switch is not engaged, the meters monitor the Left and Right Main output levels. These meters are of the peak-hold type, meaning that they register and "hold" instantaneous peaks for a bit longer than the duration of the actual peak, thereby making it easier for you to check and set levels, since you can see the maximum level (because it is held for a period of time).

Whenever a Solo switch is pushed, the meters switch from monitoring the Main Left and Right mix to metering the soloed signal. Depending on the type of solo (PFL, AFL, or Stereo In Place Solo), either the left meter (PFL/AFL) or both meters (Stereo In Place Solo) will operate. For the most accurate reading of PFL and AFL solos, it is important that the Solo Level control be turned all the way up (its calibrated nominal position). This is extremely important. If the Solo Level control is not all the way up, the meter reading will be below the real output level of the soloed output, by the amount of gain reduction incurred by the Solo Level control.

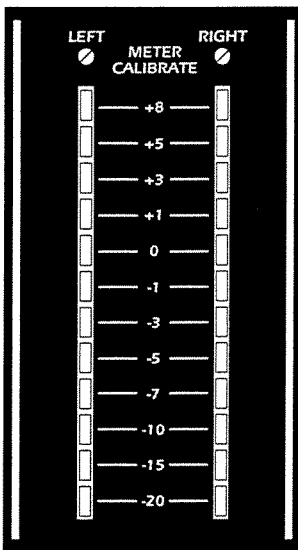

Some of the situations where it is important to have an accurate meter reading include:

- Metering the pre-fader direct output of an Input Channel (via the insert jack) when feeding the input of a multi-track recorder (PFL solo mode).
- Metering the output of a Submaster (AFL solo mode).
- Metering the output of an Aux. Send (AFL mode).
- Metering the Mono Sum output (AFL mode).

Using the MX-5200 Series' solo metering capabilities in conjunction with the input and output Peak indicators eliminates the need to scan a bank of meters to check levels and overloads, plus it helps to minimize the MX-5200 Series' weight and size.

Should you desire a larger number of meters, an optional analog (moving needle-type) VU meter bridge is available from your local Fender Electronics dealer. Installation of the optional meter bridge must be performed by an authorized Fender service center.

Whenever the 2 Track Playback button is pushed (engaged), it also switches the left and right meter from the main stereo mix, and instead takes its signal from the two 2 Track Playback phono/RCA input jacks (Left and Right) on the mixer's rear panel. This allows you not only to aurally monitor the playback from your stereo recorder (DAT, cassette, analog 2-track, or DAW—digital audio workstation), but it also allows you to meter the outputs of that recorder as well. This is helpful when calibrating an analog recorder; it's also useful in making sure all of your levels are correct at both inputs and outputs. Although this works somewhat like the Solo, it differs in that the stereo audio signal is not picked off of the stereo solo bus, but rather off of the recorder playback jacks. It is also non-destructive, however, and has no effect on the stereo Main outputs. It is very much like the tape monitor switch on a "consumer" audio receiver.

METER CALIBRATION PROCEDURE

There is one calibration trim pot for each bargraph meter, located beneath the front panel. It is set at the factory for 0dBu = 0.775 volts AC output. It can be recalibrated to other standards, but the procedure should only be undertaken by a qualified serviceperson. Do not try to adjust these controls unless you know how to use sophisticated audio test equipment and have a thorough knowledge of operating levels and audio matching.

For most applications, the factory setting is the desired calibration, although in some cases recalibration to another reference may be desirable. Here is the procedure for calibrating the meters.

1. Set a signal generator or other unbalanced sine wave signal source to produce a 1kHz signal at a level equal to the desired "0" (zero) level for the meters. Typical "0" levels include +4dBu (1.228 Volts RMS) if pro equipment constitutes the majority of the equipment connected to the mixer, or -10dBV (0.316 Volts RMS) if the connected equipment is mostly "consumer" gear. Other "0" levels may also be used.

Send the signal into Tape L, an RCA (phono) jack located on the mixer's rear panel.

2. Make sure that none of the mixer's Solo switches are pressed. (It doesn't matter if the master Enable Stereo In Place Solo switch is pressed.) Press 2 Track Playback, located in the Control Room part of the Master Section.
3. Locate the screwdriver trim control for Meter Calibrate Left, located immediately above the left LED bargraph meter in the front-panel Master Section. Adjust this trimmer so that the first yellow segment of the bargraph just begins to turn on with the desired "0" level signal.
4. Repeat the above procedure for the right bargraph meter, using the Tape R input.

Solo Section

When any Solo button is activated on the MX-5200, its signal goes through the Solo section before reaching the Control Room Outputs and Headphone Output.

Solo Level Control

The Solo Level control sets the gain for all solos. This is a necessary feature because the levels from soloed channel to soloed channel may vary greatly and need taming or boosting in the control room for adequate scrutiny. In addition, if more than one Solo switch is pressed at one time, the signals add together and can create a surprisingly high output, so the Solo Level control comes in handy for keeping the overall level from getting out of hand.

Enable Stereo In Place Solo Switch

The Enable Stereo In Place Solo switch changes the way the MX-5200's Solo functions work, switching the Solo system from PFL/AFL to a stereo in place solo.

Control Room

The Control Room Outputs are valuable for driving a set of studio monitors in a recording application, or for driving a mix-position cue wedge/monitor speaker in a live sound-reinforcement application.

The Control Room Outputs (Right and Left) contain the same material as the Main Outs, except when a Solo switch is engaged or the 2 Track Playback switch is pressed. When a Solo switch is engaged, the soloed signal reaches the Control Room section, and the signal from the stereo main mix is switched "off" in the Control Room monitor and Headphones. When the 2 Track Playback switch is pressed, any material input through the Tape In L and Tape In R phono jacks reaches the Control Room section, and the signal from the stereo main mix is switched off in the Control Room monitor and Headphones.

Note: If both the Solo and the 2 Track Playback switches are pressed simultaneously, the Solo switch overrides the 2 Track Playback. Even though the main stereo mix is disconnected in the monitors, it is still "live" at the main outputs.

Control Room Level Control

Whether the material reaching the Control Room level control is from the Tape In L and Tape In R, the Main Outs, or the Solos, this knob governs the amount of level that goes to the Control Room L and Control Room R outputs.

Headphones Level Control

Any signal reaching the Control Room outputs is also routed to the Headphone output. It passes through the Headphone Level control before reaching the internal Headphone amplifier, and finally the Headphones output jack, so its level can be set independently of the control room monitors.

2 Track Playback Switch

Pressing the 2 Track Playback switch allows the signals from the Tape In L and Tape In R to reach the Control Room section.

Mono Switch

When pressed, the Mono switch combines the left and right signals going to the Control Room and Headphone Level controls so that the signals reaching the Control Room Outputs and Headphone output are mono. This switch is especially useful when you want to check for proper phasing of the left and right signals. It is also helpful when you only want to drive a single cue wedge speaker at a mix position.

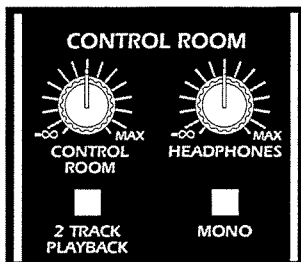
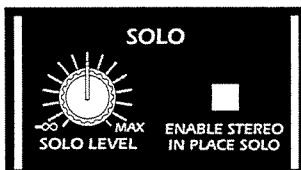

Stage Monitors

The Stage Monitors (Mon 1 and Mon 2 rear-panel XLR and 1/4" outputs) receive their signal from the mix of the Mon 1 and Mon 2 Send controls on the Input Channels and the Effects Returns (either pre-EQ/pre-fader or post-EQ/post-fader, depending on each Input Channel's Monitor Pre/Post switch setting).

Monitor (Master) Level Control (1-2)

The final level of all monitor sends from the channels and Effects Returns is set by the Mon 1 and Mon 2 Master Level controls. The Master Level control comes before the Parametric Equalizer, if it's switched into the Stage Monitors' signal paths (far left position of the 3-position equalizer-assignment switch).

Monitor Solo Switch

The Solo button on the Monitor channels operates in two different ways, depending on whether the Enable Stereo In Place Solo button in the Master section is pressed to its "in" position. (For information on the effect of the Solo and Enable Stereo In Place Solo functions, see page 21.)

When the Enable Stereo In Place Solo button is in its "out" position (disabled) and a Monitor's Solo button is pressed, the mono post-fader/pre-Mute (after-fader listen, or AFL) signal is sent to both the left and right control room and headphone outputs. The left meter monitors the signal's level.

When the Enable Stereo In Place Solo button is in its "in" position (enabled) and a Monitor's Solo button is pressed, the left channel's mono post-fader/pre-Mute (after-fader listen, or AFL) signal is sent to the left Control Room and Headphones outputs. The left meter monitors the signal's level.

Monitor Solo LED Indicator

When the Solo switch is engaged, the LED indicator glows until the Solo switch is pressed again to disengage the function.

Monitor Mute Switch & Mute LED

When the Mute switch is pressed, its LED illuminates and the signal to the Monitor Out XLR and 1/4" jacks is muted. No signal reaches these jacks again until the Mute switch is pressed, releasing Mute mode (the LED goes dark).

Peak Indicator LED

A peak-detector circuit monitors the Stage Monitors channel's signal and glows when the level exceeds 6dB below its clipping point. This is helpful to prevent clipping, and it alleviates the need for a separate monitor LED VU meter (you can still meter the output of Monitor 1 and/or Monitor 2 by using the Solo switch).

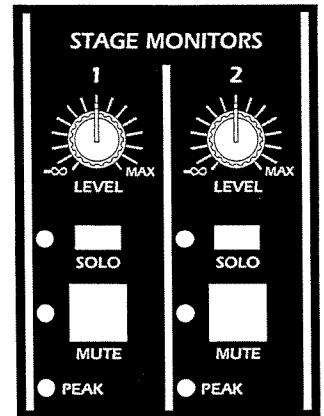

Submaster Section (1-4)

The MX-5200 Series mixers are configured as four-Submaster/stereo master/mono sum consoles. They may also be used as six-Submaster/mono master consoles if desired.

Submasters are extremely handy features on a mixing console, in both recording and sound-reinforcement applications. In a studio, the left and right main mix buses can be used for mixdown and off-tape monitoring (using the board in a "split" configuration), with the output of the multi-track recorder plugged into the appropriate number of Input Channels, with those channels assigned only to the stereo mains. The free (or remaining) Input Channels can then be assigned to the Submasters and "grouped" as required (for example, tom-toms left and right) and mixed together and routed to selected multi-track inputs, along with direct outputs from individual microphones (via the Input Channels' access jacks used as direct outputs) In this manner, the MX-5200 Series mixer may be used as a powerful studio console.

For sound-reinforcement use, Submasters allow you to group related inputs (e.g., a drum kit, background vocalists, keyboards, etc.) and to vary the level of the entire subgroup with only one fader, no matter how many inputs are assigned to that subgroup.

The Submaster section allows you to create a sub-mix (in mono or in stereo, when two submasters are used) by accepting signals from each Input Channel (post-EQ/post-fader/post-Pan/post-Mute switches), and then routing them to the Submaster Outputs and/or the Main stereo output section. The Submasters can then be taken directly out of the board, or assigned to the stereo main mix and placed in the stereo sound field using the Submaster Pan pot. Mixing via the Submaster section and sending the signal out through the Submaster outputs lets you assign specific Submasters to be, for example, additional reverb sends or sends to the MX-5200's Parametric Equalizers before returning the signals to the stereo main mix.

Submaster Main (Assignment) Switch

This switch assigns the Submaster to the stereo main mix bus. This allows you to set up a subgroup (such as drums, keyboards, backing vocals, etc.) and adjust the level of the entire group—without having to adjust all of the input faders assigned to the group at the same time.

When this switch is pressed, the Submaster's post-fader/post-Mute signal passes through the Pan control and is sent to the Left Main and Right Main buses.

Pan Control

This control governs the relative amounts of the mono Submaster signal being sent to each of the Main buses.

Solo Switch & LED Indicator

When the Solo switch is engaged, the LED indicator glows until the Solo switch is pressed again to disengage the function. The Solo button on each Submaster channel operates in two different ways, depending on whether the Enable Stereo In Place Solo button in the Master section is pressed to its "in" position. (For information on the effect of the Solo and Enable Stereo In Place Solo functions, see page 21.)

When the Enable Stereo In Place Solo button is in its "out" position (disabled) and a

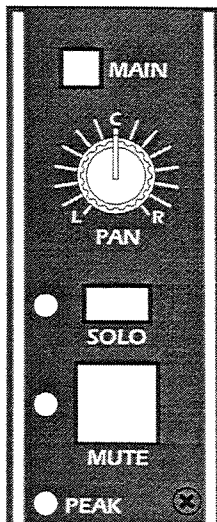
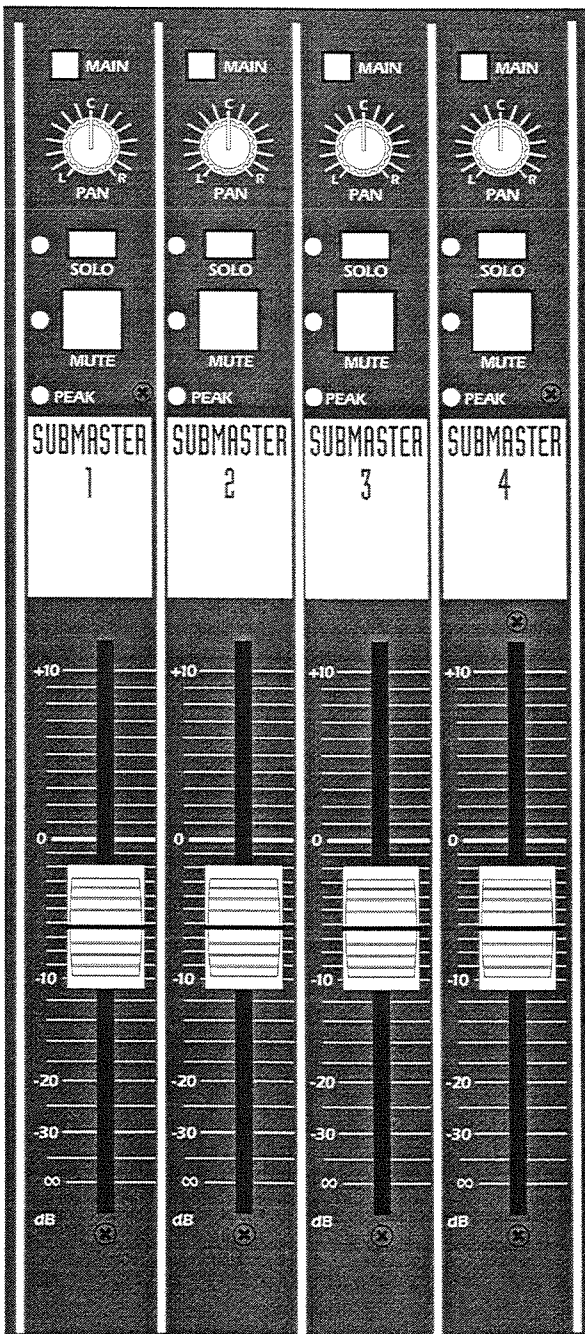

Submaster's Solo button is pressed, the post-Mute/post-Pan signal is summed to mono and then sent to both the left and right Control Room and Headphones outputs. The left and right meters monitor the levels on the left and right channels.

When the Enable Stereo In Place Solo button is in its "in" (enabled) position and a Submaster's Solo button is pressed, an In Place Stereo signal from the post-Mute/post-Pan location is sent to both the left and right Control Room and Headphones outputs. The left and right meters monitor these stereo signals.

Mute Switch & LED Indicator

The signal to the Submaster output, as well as the Main, Solo, Headphones, and Mono outputs is muted when this switch is pressed. Its LED glows to indicate that the Mute is engaged.

Peak Indicator LED Indicator

A peak-detector circuit monitors the Submaster's signal and glows when the level exceeds 6dB below its clipping point.

Submaster Fader

Each Submaster Fader adjusts the level to its corresponding Submaster output, post-Insert point.

Stereo Main Mix (Master) Section

The Main section consists of the two Left Main and Right Main outputs and their faders, as well as the Mono Output and its level control. The Main L and Main R insert jacks on the rear panel are pre-fader, so the level of any effects added at those points are controlled by the faders. Note that the Left Main and Right Main sections are identical.

LEFT MAIN

Left Main Mute Switch & LED Indicator

The Mute switch mutes the signal going from the Left Main fader to the Main Left Outputs (XLR and 1/4") as well as to the Mono Out. When the Mute switch is engaged, the LED indicator glows until the Mute switch is pressed again to disengage the function.

Peak Indicator LED Indicator

A peak-detector circuit monitors the signal at points before and after the Main L insert and fader, and glows when the level exceeds 6dB below its clipping point. This is helpful in cases where something has been soloed and the left meter is not currently reading the left main output. This LED allows you to catch an overload condition on the left main output.

Left Main Fader

This 100mm fader governs the level reaching the Main Left Outs (XLR and 1/4"), as well as the level of the Left Main signal being fed to the summing amplifier that drives the Mono Out.

RIGHT MAIN

Right Main Mute Switch & LED Indicator

The Mute switch mutes the signal going from the Right Main fader to the Main Right Outputs (XLR and 1/4") as well as to the Mono Out. When the Mute switch is engaged, the LED indicator glows until the Mute switch is pressed again to disengage the function.

Peak Indicator LED

A peak-detector circuit monitors the Main channel's signal and glows when the level exceeds 6dB below its clipping point.

Right Main Fader

This 100mm fader governs the level reaching the Main Right Outs (XLR and 1/4"), as well as the level of the Right Main signal being fed to the summing amplifier that drives the Mono Out.

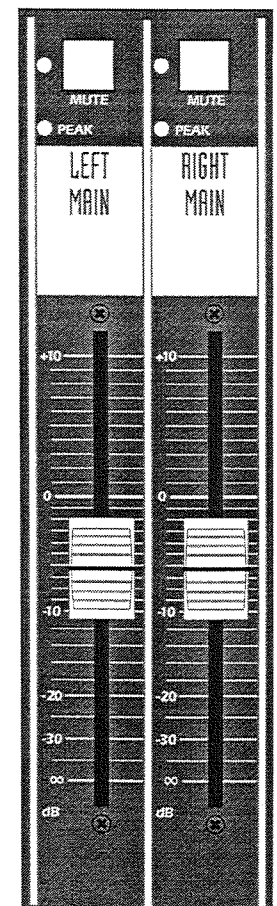
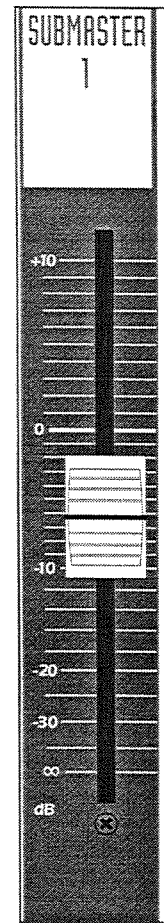

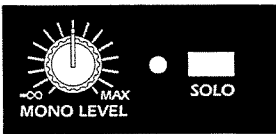

Mono Master Level

The Mono Level Master controls the combined (summed) Left Main and Right Main signal reaching the 1/4" Mono Output jack. This allows the console to be used as a 6-Submaster/mono master console, if desired. It is also useful for creating a mono mix from the stereo, for feeding a center vocal cluster (in left/center/right sound-reinforcement systems), or for driving a mono subwoofer feed that can be brought up separately.

Mono Master Solo Switch & LED Indicator

This switch activates AFL solo in place only, so you can actually meter the true output of the Mono sum output. You'll be able to examine the output after the Level control (be sure the Solo Level is all the way up). When the Solo switch is pressed, activating the Solo mode, the LED glows.

REAR PANEL

Control Room Outputs (L&R)

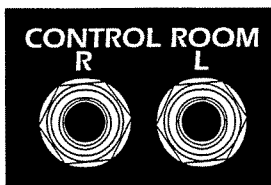

The two Control Room Outputs are 1/4" unbalanced mono (two-conductor tip/sleeve) jacks carrying the signal whose gain is adjusted by the Control Room Level knob in the Master section.

EQ In/Out

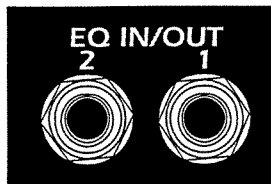

The jacks labeled EQ In/Out 1 and 2 are 1/4" TRS send/return jacks for Parametric Equalizers 1 and 2, respectively. The jack's tip is the input to the equalizer; the ring is the output. Because of the way the jacks are wired, it's possible to use a standard stereo (3-conductor) cord with 1/4" TRS plugs at both ends to patch either Parametric Equalizer into any insert jack on the MX-5200 (Input Channel inserts, Submaster inserts, or Master inserts).

Returns (Left 1-4 & Right 1-4)

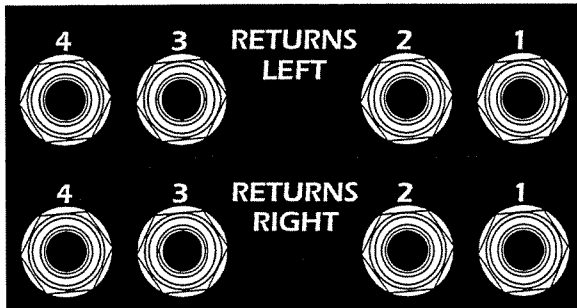

There are four left/right pairs of returns, numbered 1 through 4. Each is an unbalanced 1/4" TS (tip/sleeve) jack with a normally closed switch. The tip is wired as the signal "hot," and the sleeve is the ground. If a plug is inserted into only the left or right return of a pair (example: plugging into Right Return 1 but not into Left Return 1), then the jack's internal switch routes the signal to both returns, making the net effect mono. If plugs are inserted into both jacks of a pair (example: Right Return 1 and Left Return 1), then each return is separate, which in effect makes the return pair stereo.

Submaster Inserts 1-4

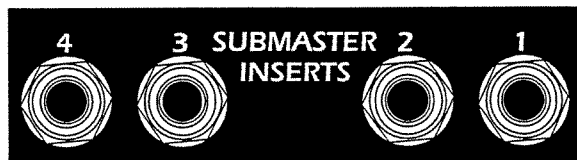

The Submaster Inserts are 1/4" TRS jacks with normally closed switches. The Tip is the send, and the ring is the return. When no plug is inserted, the Send and Return are normalled together, so the signal from the Submaster bus proceeds to the Submaster fader for that bus without interruption.

Inserting a plug fully into the jack breaks the normal between the Send and Return, and allows individual access to these signals. A standard stereo cord with 1/4" TRS plugs at both ends can be used to patch into either Parametric Equalizer. A "Y" cord with a 1/4" TRS plug and two 1/4" mono plugs can be used for patching outboard processors into any of the Submaster inserts. See the description and diagrams of the Input Channel insert jacks on pages 21 and 22 for instructions on how to make an insert cable, and a direct-out cable that also allows the Submaster to feed the Mains (post-fader and Pan) while taking a direct out (pre-fader).

Submaster Outputs 1-4

Each of these four unbalanced 1/4" mono outputs provides a variable-

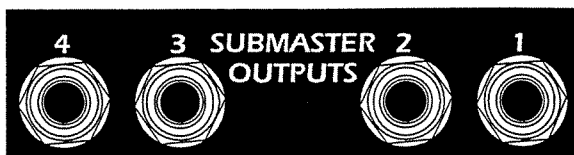

level signal after its corresponding Submaster fader. Each jack is wired with its tip carrying the signal and the ring connected to ground.

Auxiliary Outputs 1-4

Each of these four unbalanced 1/4" mono outputs provides a variable-level signal after its corresponding Auxiliary Master Level control.



Mono Out

This balanced 1/4" TRS jack is wired so that the positive (+) signal is carried on its tip, and its inverted (-) signal is carried on its ring. In mono unbalanced applications, the ring is shorted to ground. The signal is a combination of the Left and Right Main outputs, post Mains fader.

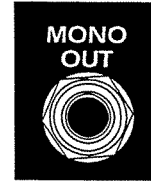

Tape In, Left & Right

These two mono unbalanced phono (RCA) jacks accept -10dBV line-level signals from stereo tape recorders, DAWs, CD players, etc. Their input impedance is 10k ohms. Like other signals reaching the Control Room and Headphones outputs, the Control Room Mono switch can combine them into mono, and the level of the signals is controlled by the Control Room Level and Headphones Level controls.

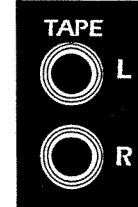

Main Inserts, Left & Right

The two Main Inserts are 1/4" TRS jacks with normally closed switches. The Tip is the send, and the ring is the return. When no plug is inserted, the Send and Return are normalled together, so the signal from the Main bus proceeds to the corresponding Mains fader without interruption.

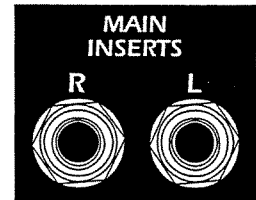

Inserting a plug fully into the jack breaks the normal between the Send and Return, and allows individual access to these signals. A standard stereo cord with 1/4" TRS plugs at both ends can be used to patch into either Parametric Equalizer. Alternatively, a "Y" cord with a 1/4" TRS plug and two 1/4" mono plugs can be used for patching outboard processors into either Main Insert. A direct-out adapter cable may also be used.

Monitor Outs 1 & 2

The balanced 1/4" TRS jacks are wired so that the positive (+) signal is carried on the tip, and the inverted (-) signal is carried on the ring. In mono unbalanced applications, the ring is shorted to ground. The XLR outputs are also balanced, with the "+" signal on pin 2 and the "-" signal on pin 3. These outputs carry the post-monitor-(Master) level signal. Also, if one of the Parametric Equalizers is in the monitor signal path, it follows the Level control but precedes the outputs.

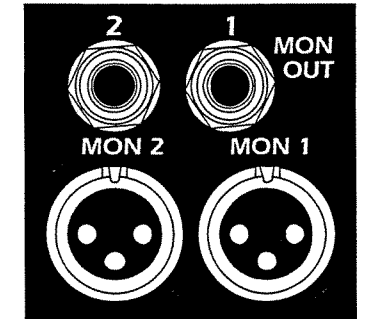

Main Outs Left & Right

The balanced 1/4" and XLR jacks for both the Main Left and Main Right outputs are wired so that they are both balanced. The 1/4" jack's tip carries the positive (+) signal, and the ring carries the inverted (-) signal. The XLR outputs are configured with the "+" signal on pin 2 and the "-" signal on pin 3. These outputs carry the stereo signal from all sources being directed to the main bus, and are monitored by an LED peak indicator.

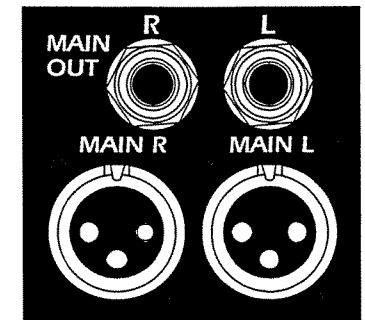

Channel Inputs & Inserts

Each Input Channel has an identical three-jack complement: a Line Input, a Mic Input, and a Channel Insert/Direct Out jack. The Channel Insert is pre-EQ/pre-fader, but post-preamp. Therefore, the Trim control sets the level being sent to the Channel Insert.

Channel Insert/Direct Out Jack

The Channel Insert is a 1/4" TRS jack that acts as both the send and return by placing the send signal on the tip and the return signal on the ring. When no plug is inserted, the Send and Return are normalled together (that is, they are connected automatically), so the signal from the preceding stage (the preamp) goes directly to subsequent stages (EQ, etc.) without interruption.

Inserting a plug fully into the jack breaks the "normal" between the Send and Return, and allows individual access to these signals. A standard stereo cord with 1/4" TRS plugs at both ends can be used to patch into either Parametric Equalizer. Alternatively, a "Y" cord with a 1/4" TRS plug and two 1/4" mono plugs can be used for patching outboard processors into an Input Channel Insert. A direct out adapter cable may also be used. See pages 24 and 25 for directions on making these cables.

Line Input

This 1/4" input is designed to accept either balanced signals via TRS plugs or unbalanced signals via mono TS (tip/sleeve) plugs. To do this, the tip is configured as the "+" input, and the ring is the "-." When a mono, unbalanced source is input via a mono plug, the ring shorts to ground.

Mic Input (XLR)

The Mic Input is a balanced XLR jack with its pin 2 wired to accept the "+" signal and pin 3 wired to accept the "-" signal. Pin 1 is ground.

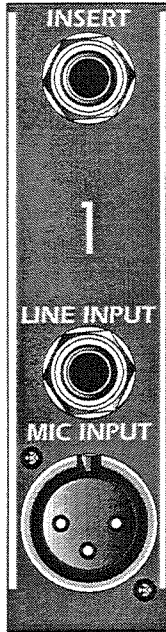

OTHER REAR-PANEL CONNECTORS

SysFlex™ Expansion Ports

Optional circuitry with a pair of DB-15 connectors labeled Sysflex 1 and Sysflex 2 can be installed by your Fender Electronics dealer. Sysflex™ provides a simple means of connecting two or more MX-5200 Series mixing consoles to expand the number of channels and Submaster buses (if desired).

Power Interconnect

This round, twist-lock multi-pin connector is the input for all power coming from the CPSM-4 power supply. See page 39 for more information on the power supply. Always keep this connector clean and dry, and avoid damaging the pins inside the connector.

VCA Control Option

Optional VCA (voltage-controlled amplifier) automation may be installed in your MX-5200 Series mixing console to give you remote MIDI control over Level and Mute functions within the mixer. Removable panel covers on the rear of the MX-5200 consoles provide the location for mounting the connectors for interfacing the VCA circuitry and external controllers. Consult your Fender Electronics dealer for further information on availability, installation, and operation of the optional VCA circuitry and Fender MX-Autosoft™ software.

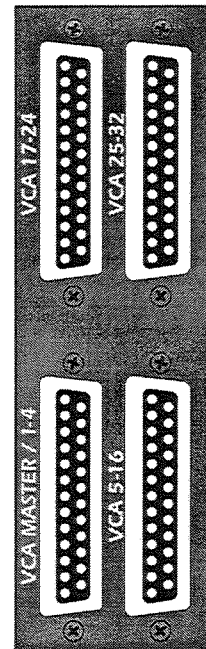
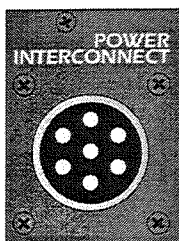
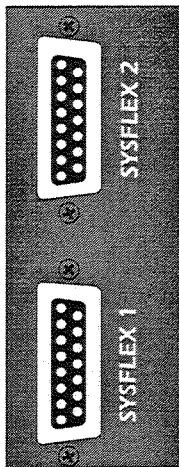

THE POWER SUPPLY

The CPSM-4 power supply module is designed specifically for the MX-5200 Series mixers, and is engineered to deliver reliable, well-regulated power. It has extensive short-circuit and thermal protection, making it extremely reliable in a variety of environments. Separate short-circuit protection on all power leads (+18V, -18V, +48V, and +12V) ensures that the CPSM-4 is guarded against failure not only in its primary power to the MX-5200 audio circuitry (the +18V and -18V supplies), but the phantom powering (+48V) and lamp illumination/logic circuitry/meter bridge power (+12V) as well. If there is ever a fault in any of the lines, the corresponding LED on the power supply's front panel will go out. These LEDs remain lit as long as all portions of the power supply are functioning properly.

To provide thermal protection against damaging heat build-up, the CPSM-4 has a built-in fan and large vents on the front and rear panel. The fan's speed is determined by the amount of heat present in the power supply's enclosure; as greater demands are placed on the supply, ventilation is increased.

Internal fuses protect against damage to the CPSM-4 in the event of extreme overload situations. Under normal operation, the fuses should never blow. If they do, refer service to qualified personnel only.



Note: Opening the CPSM-4 or MX-5200 console voids your warranty. Fuse replacement or other work undertaken inside of either unit must be performed by an authorized Fender Electronics service technician.

Diode steering circuitry inside the CPSM-4 allows two CPSM-4 power supplies to be linked with an optional adapter box for fully redundant operation; that is, if one power supply fails, the other will take over without interruption. (Consult your Fender Electronics dealer for information on the adapter box and cable for connecting a second CPSM-4 power supply to your MX-5200.) The CPSM-4 is designed to fit a half-rack width and is three rack units high. Two CPSM-4s can be attached side by side on an optional rack-mounting tray for convenient placement with other road or studio gear.

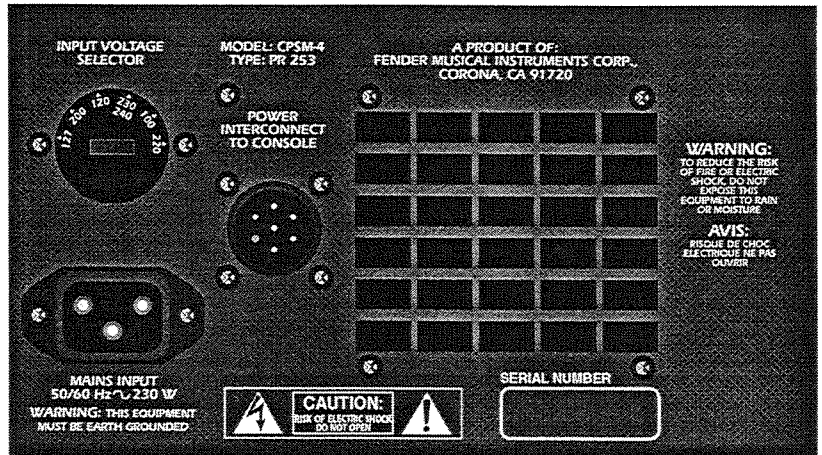
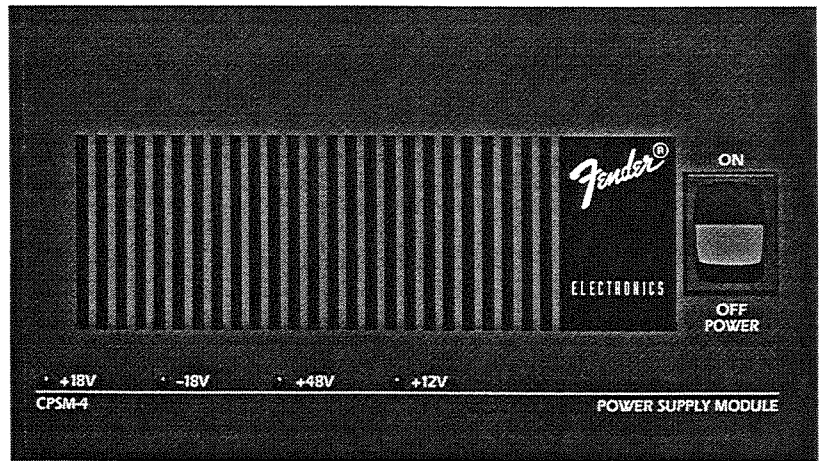

TROUBLESHOOTING YOUR MX-5200 SERIES MIXER

Many operating difficulties arising in electronic equipment are easily remedied. Naturally, some equipment fails to work because it is damaged or has suffered some sort of failure and must be serviced by a qualified service person. However, some problems are just a matter of making the right connections, making sure the power is on, etc. So, if you should experience difficulty with your MX-5200 Series mixing console, check the following before you take it in for repair:

Power

Is the CPSM-4's AC (Mains) power cord properly plugged into an electrical outlet?

Is there power at the outlet? (Try plugging in something that you know works, such as a fan, light, etc.)

Is the interconnect cable securely plugged into both the CPSM-4 power supply and the MX-5200 Series mixer?

Is the CPSM-4 Power Supply's power switch in the "on" position?

Are the CPSM-4 Power Supply's LEDs glowing? If the AC (Mains) power is good and the power switch is turned on, but none of the LEDs glow, then the internal fuses may be blown. If some of the LEDs glow, but others do not, then the likely cause is a circuit problem in the power supply. Refer the CPSM-4 to qualified service personnel for repair.

Does the LED labeled "Power" on the MX-5200 Series console glow? If it does not, but the CPSM-4 Power Supply's LEDs are illuminated, then the problem may be with the interconnect cable between the two units. Make sure it is not damaged. If it is, replace it with the same type of cable.

Power Amp & Speakers

Is the power amplifier plugged into a "live" AC (mains) outlet and turned on?

Is the power amplifier properly connected to the mixer?

Are speakers connected to the power amplifier?

Are all the appropriate control knobs turned up?

Mixer & Sound Source

Make sure that your sound source's signal is reaching the mixer. A good indication comes from the meters. Try soloing (PFL) the Input Channel to be sure you have a signal.

Are all the appropriate control knobs and faders on the mixer turned up?

Are Mute or Solo switches pushed? Make sure that the Mute switch isn't pushed for the channel into which you're sending the sound source's signal, and make sure that other Solo switches aren't pushed.

Is your sound source properly plugged into the mixer?

If there is no meter activity on the left and right Mains, is a Solo switch or the 2 Track Playback switch pushed?

If the sound source has a power switch, is it turned on?

If the sound source has a volume control, is it turned up?

If any signal processors are patched into insert points, remove them from the loop to see if the problem is caused by something wrong with the signal processors. It is possible that the insert cable or its plugs are damaged, too.

If, after checking all of the above, the system is still not working correctly, consult your Fender Service Dealer.

SPECIFICATIONS FOR FENDER MX-5200 SERIES MIXERS

Frequency Response: 20 Hz to 20kHz \pm 1dB

Distortion (any input to any output): Less than .02% 20 Hz to 20kHz

Microphone Equivalent Input Noise: -133.8dBV input shorted,
-131.5dBV 150-ohm source impedance

Max output: +28dBu on all balanced outputs
+22dBu on all unbalanced outputs

Maximum gain (Mic Input to balanced main output): 90dB

Maximum gain (Mic Input to unbalanced sub output): 84dB

Bus noise: <90dBu (20 Hz to 20kHz, all channels assigned and muted)

Dynamic range: 116dB (20 Hz to 20kHz)

Adjacent Channel Crosstalk: -85dB

Mic Input Gain: 25dB to 70dB (to balanced main output, all faders at "0")

Line Input Gain: 5dB to 50dB (to balanced main output, all faders at "0")

Channel Fader Gain: 10dB

Channel Fader Attenuation: \geq -95dB

Width: MX-5216, 33" (84 cm); MX-5224, 42" (107 cm); MX-5232, 51" (130 cm)

Depth: 24.50" (62.2 cm)

Height: 6.53" (16.6 cm)

Weight: MX-5216, 39 lbs (17.7 kg); MX-5224, 52 lbs (23.6 kg); MX-5232, 65 lbs (29.5 kg)

CPSM-4 Power Supply Dimensions

Width: 8.5" (21.6 cm)

Depth: 13.125" (33.3 cm)

Height: 4.75" (12 cm)

Weight: 17 lbs (7.7 kg)

Due to our policy of continuous product improvement, features, prices, and specifications are subject to change without notice.

Fender, Fender Pro Audio, SysFlex, MX-AutoSoft, AutoSoft, and the MX-5200 Series are trademarks of Fender Musical Instruments Corporation. Apple and Macintosh are trademarks of the Apple Computer Corp.

Copyright 1994, Fender Musical Instruments Corporation.

Fender Musical Instruments Corporation—7975 North Hayden Road, Ste. C-100, Scottsdale, Arizona 85258-3241

INTERCONNECTING CABLES, GROUNDING, AND TROUBLESHOOTING

Interconnecting electronic gear with an MX-5200 Series mixing console provides you with a powerful integrated system for shaping and routing sounds. Unfortunately, it can also introduce hum- and noise-inducing ground loops (multiple paths to ground). In order to minimize the chances of ground loops being created, it's necessary to use properly configured interconnecting cables. The chart below indicates which type of cable configuration should be used for each type of MX-5200 Series mixer input and output (diagrams on the next page show you how each cable should be wired).

Notes:

1. "Optional cable" type will work electrically and may be acceptable in some instances, but might cause hum problems in many cases.
2. Refer to the list below to determine which outputs and inputs on the MX-5200 are balanced. Check the owner's manual for other gear (or consult the manufacturer) to determine whether the inputs and outputs of that gear are balanced or unbalanced.

MX-5200 Output	External Equipment Input	Preferred Cable	Optional Cable
Balanced	Balanced	Figure A	
Balanced	Unbalanced	Figure B	Figure A
Unbalanced	Balanced	Figure A	
Unbalanced	Unbalanced	Figure B	Figure A

External Equipment Output	MX-5200 Input	Preferred Cable	Optional Cable
Balanced	Balanced	Figure A	
Balanced	Unbalanced	Figure A	
Unbalanced	Balanced	Figure C	
Unbalanced	Unbalanced	Figure B	Figure A
Guitar Or Unbalanced Direct Box (For Balanced Direct Box, Use Figure A)	Balanced Line Or Mic Input	Figure H	Figure C

Other Connections:

Any connection between any two jacks within the MX-5200	Use Figure A
Any MX-5200 Insert jack to external equipment	Use Figure D or E, as appropriate
MX-5200 EQ access jacks to external equipment	Use Figure F or G, as appropriate

Summary Of MX-5200 Output Types

Main Left and Main Right	Balanced TRS Or XLR
Mono Out	Balanced TRS Or XLR
Monitor 1 and Monitor 2	Balanced TRS Or XLR
Insert Sends	As Indicated Above
EQ Access Points	As Indicated Above
All Other Outputs	3-Wire, Unbalanced

Summary Of MX-5200 Input Types

Mic	Balanced TRS
Line	Balanced TRS
Insert Returns	As Indicated Above
EQ Access Points	As Indicated Above
Effects Return Inputs	3-Wire, Unbalanced TRS
Tape Inputs	2-Wire Unbalanced RCA (Phono)

Note: All cables have three wires and are configured either as male-to-female XLR or as 1/4" TRS to 1/4" TRS, except where indicated.

Figure A: Standard Stereo Cable

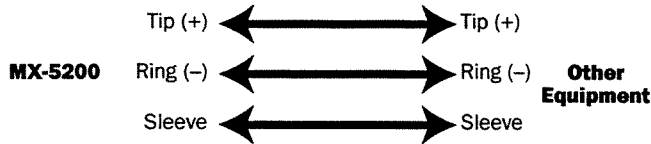

Figure B: Modified Stereo Cable #1

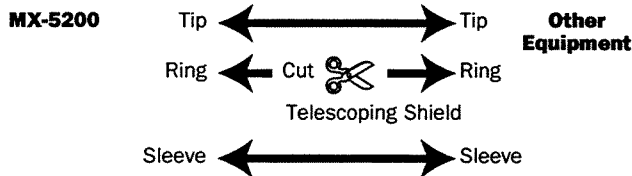

Figure C: Mono Cable

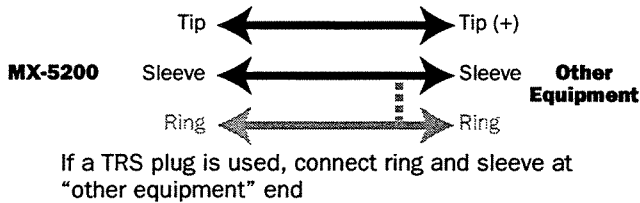

Figure D: Insert Point To Unbalanced Equipment

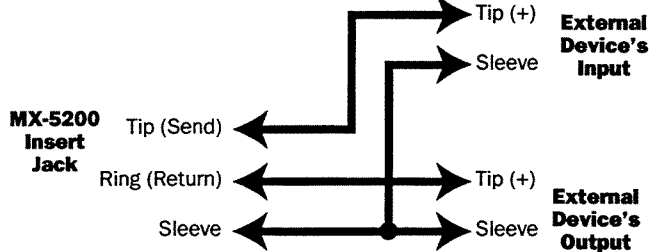

Figure E: Insert Point To Balanced Equipment

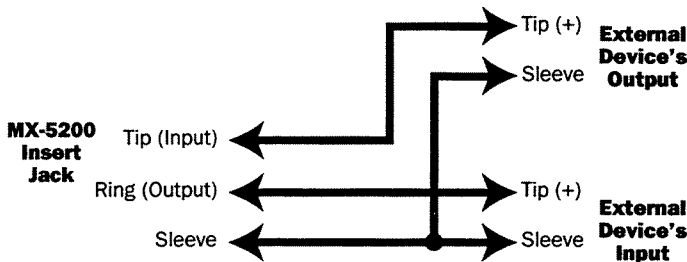

Figure F: EQ Insert To Unbalanced Equipment

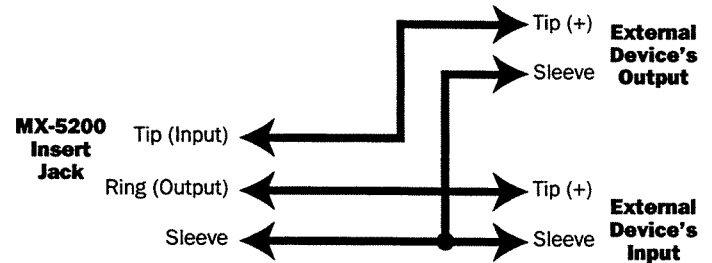

Figure G: EQ Insert To Balanced Equipment

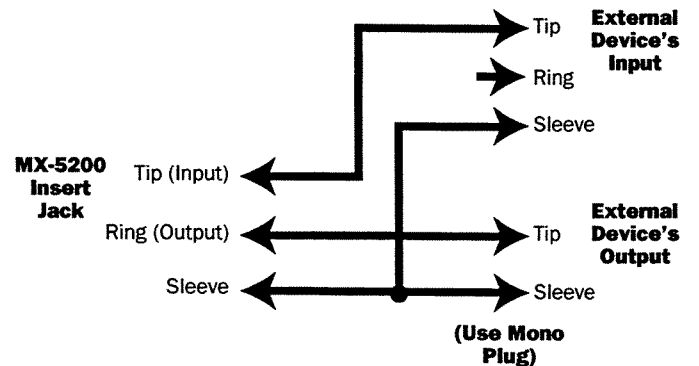
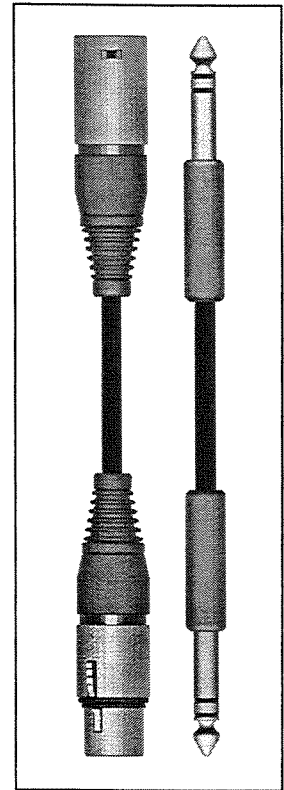
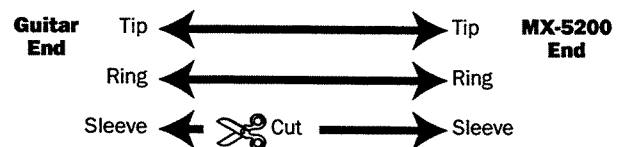

Figure H: Modified Cable #2



FENDER ELECTRONIC PRODUCTS LIMITED WARRANTY

This limited warranty against defects in material and workmanship applies only to the original purchaser when a Fender product is purchased from an Authorized Fender Dealer.

Important: Please retain your sales receipt, as it is your proof of purchase entitling you to coverage by your limited warranty. This limited warranty is void without such sales receipt.

Defective products presented during the applicable warranty period with proof of purchase will be repaired without charge if the product is returned to any Authorized Fender Dealer or Fender Service Center. All Fender Electronic Products carry a Three Year Limited Warranty from date of purchase, except that light bulbs, vacuum tubes, and meters carry only a Ninety Day Warranty from date of purchase, and Speakers carry only a One Year Warranty from date of purchase. Any repair or service performed by any person or entity other than an Authorized Fender Dealer or Fender Service Center is not covered by this limited warranty. Transportation costs are not included in this limited warranty.

This limited warranty becomes void if the serial number on any product is defaced or removed, or the product has been damaged by alteration, misuse, rental, accident, or neglect; or the product has been repaired or serviced by persons not authorized by Fender Musical Instruments Corporation. Fender assumes no liability for property damage of any sort, whether to a Fender product or to any other property, which may result from the failure of any Fender Electronic Product. Any warranties implied by law are limited to the duration of this express limited warranty. There are no warranties which extend beyond the description on the face hereof.

This limited warranty does not cover any Fender electric or acoustic guitars or strings, parts or accessories for any Fender product.

Some states do not allow limitations on how long an implied warranty lasts, so the above time limitations may not apply to you. Some states do not allow exclusions or limitations of incidental or consequential damages, so the above limitation or exclusion may not apply to you.

This warranty gives you specific legal rights, and you may also have other rights which vary from state to state.

Have service performed by any Authorized Fender Service Center or contact:

Product Service Department
Fender Musical Instruments Corporation
7975 North Hayden Road, Ste. C-100
Scottsdale, AZ 85258-3241
(602) 596-7171

SETUP EXAMPLES

Diagrams on pages 45 through 54 illustrate six applications for the MX-5200 Series mixer, in both studio and onstage environments. Multiple MX-5200 Series mixers can be linked, and systems expanded to suit any size of venue.

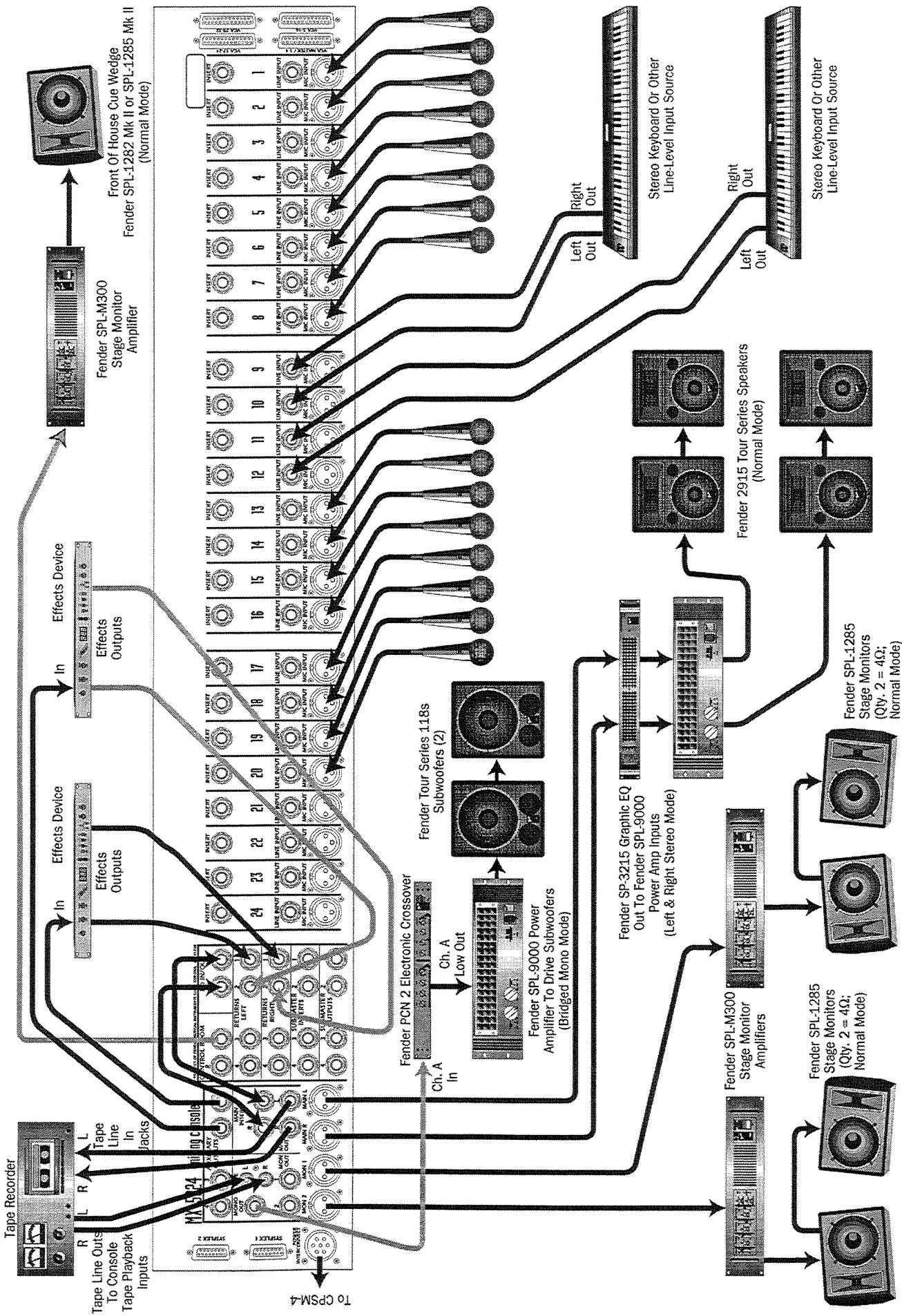

EXAMPLE TWO A small stereo P.A. with two external monitor systems, front-of-house cue wedge, mono subwoofer, and a stereo recording mix.

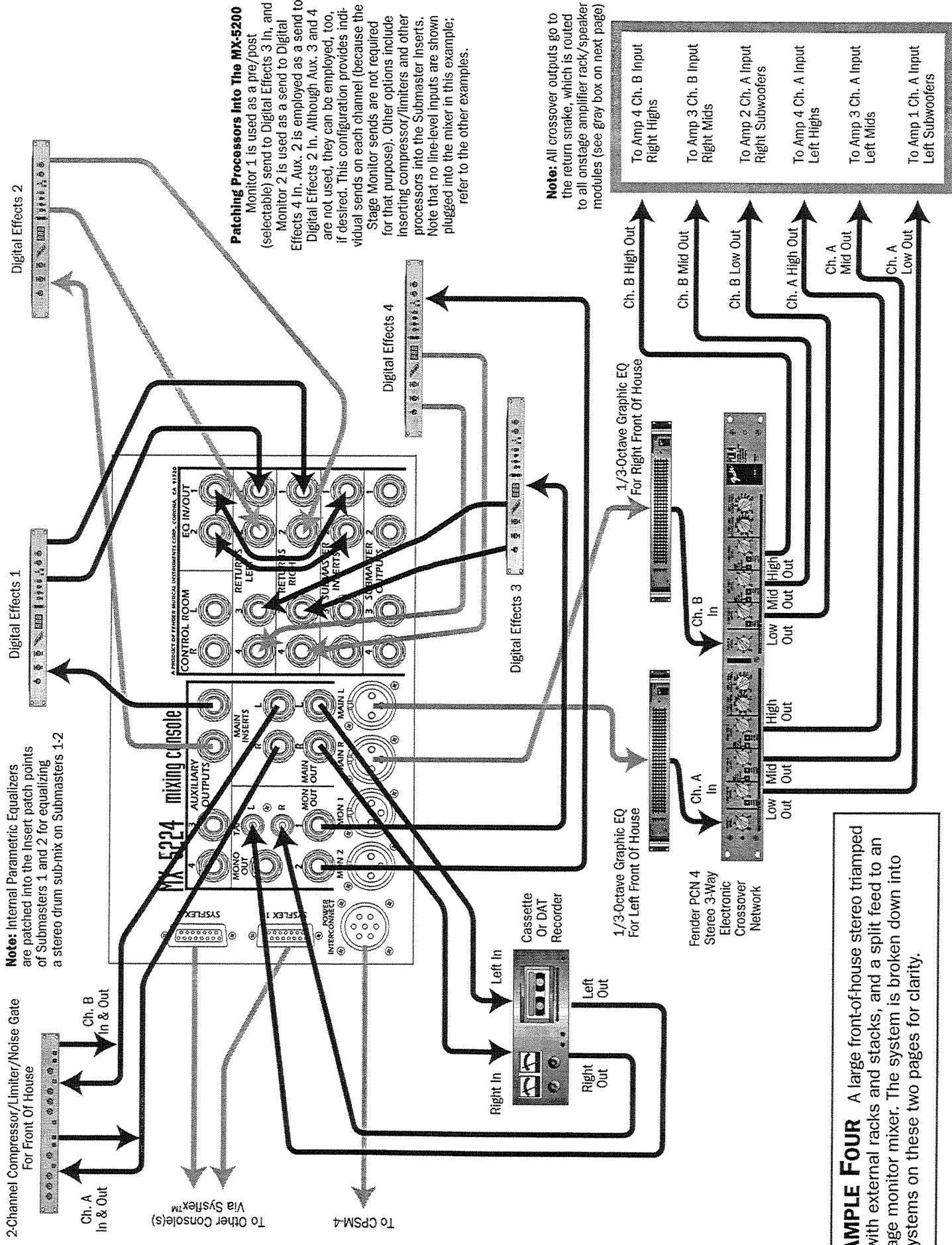

Note: Internal Parametric Equalizers are patched into the Insert patch points of Submasters 1 and 2 for equalizing a stereo drum sub-mix on Submasters 1-2

2-Channel Compressor/Limiter/Noise Gate For Front Of House
Ch. A In & Out
Ch. B In & Out

Via Sysflex™ To Other Console(s)

To CPM-4

Patching Processors Into The MX-5200
Monitor 1 is used as a pre/post (selectable) send to Digital Effects 3 In, and Monitor 2 is used as a send to Digital Effects 4 In. Aux. 2 is employed as a send to Digital Effects 2 In. Although Aux. 3 and 4 are not used, they can be employed, too, if desired. This configuration provides individual sends on each channel (because the Stage Monitor sends are not required for that purpose). Other options include inserting compressor/limiters and other processors into the Submaster inserts. Note that no line-level inputs are shown plugged into the mixer in this example; refer to the other examples.

Note: All crossover outputs go to the return snake, which is routed to all onstage amplifier rack/speaker modules (see gray box on next page)

- To Amp 4 Ch. B Input Right Highs
- To Amp 3 Ch. B Input Right Mids
- To Amp 2 Ch. A Input Right Subwoofers
- To Amp 4 Ch. A Input Left Highs
- To Amp 3 Ch. A Input Left Mids
- To Amp 1 Ch. A Input Left Subwoofers

EXAMPLE FOUR A large front-of-house stereo triamped P.A. with external racks and stacks, and a split feed to an onstage monitor mixer. The system is broken down into subsystems on these two pages for clarity.

Near-Field Monitor Speakers
On Top Of Console
(Arrival Times Are Synchronized
To The Main Front Of House
System Using A Stereo Digital
Time Delay). If A Less Elaborate
System Is Desired, Use A Simple
Cue Wedge, As Shown In Example 3.

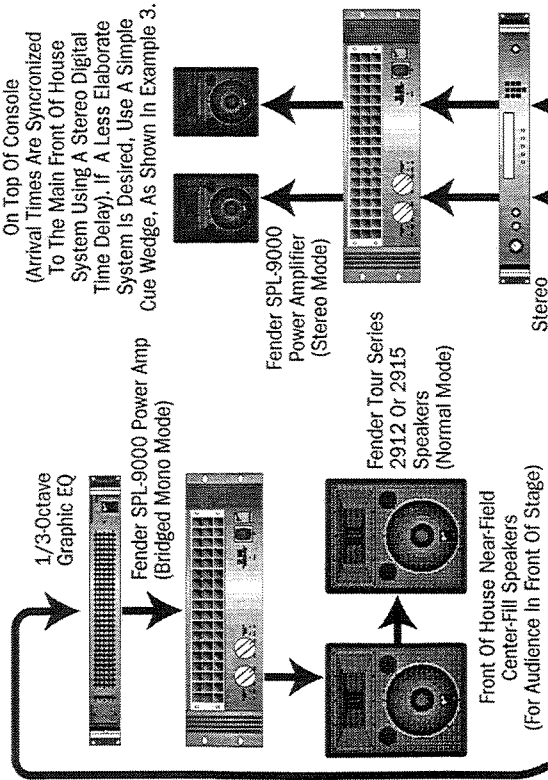

Front Of House Speaker System:
Four Fender Tour Series 118s or 215s
Subwoofers And Four Fender Tour
Series 2912 or 2915 Full-Range
Systems (Biamp Mode)

Amp 4: Stereo SPL-6000 To
Left & Right High-Frequency Drivers
Amp 3: Stereo SPL-9000 To
Left & Right Midrange Drivers
Amp 2: Bridged Mono SPL-9000
To Right Subwoofers
Amp 1: Bridged Mono SPL-9000
To Left Subwoofers

Use one of these power-amp/speaker
complements on each side of the stage.
Add more racks and stacks for larger
venues.

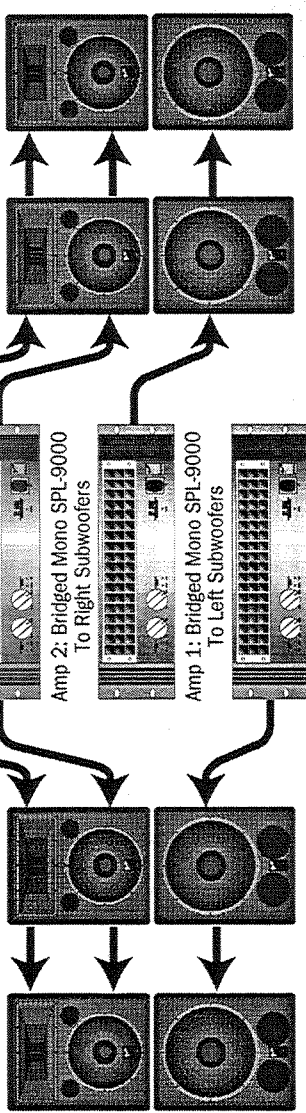

Digital Effects

Note: Input-channel signal processors,
including compressor/limiter/noise gates,
digital effects, and equalizers, can
be patched into each channel's Insert
patch point as needed

2-Channel Compressor/Limiter/Noise Gate
Ch. A
In & Out
Ch. B
In & Out

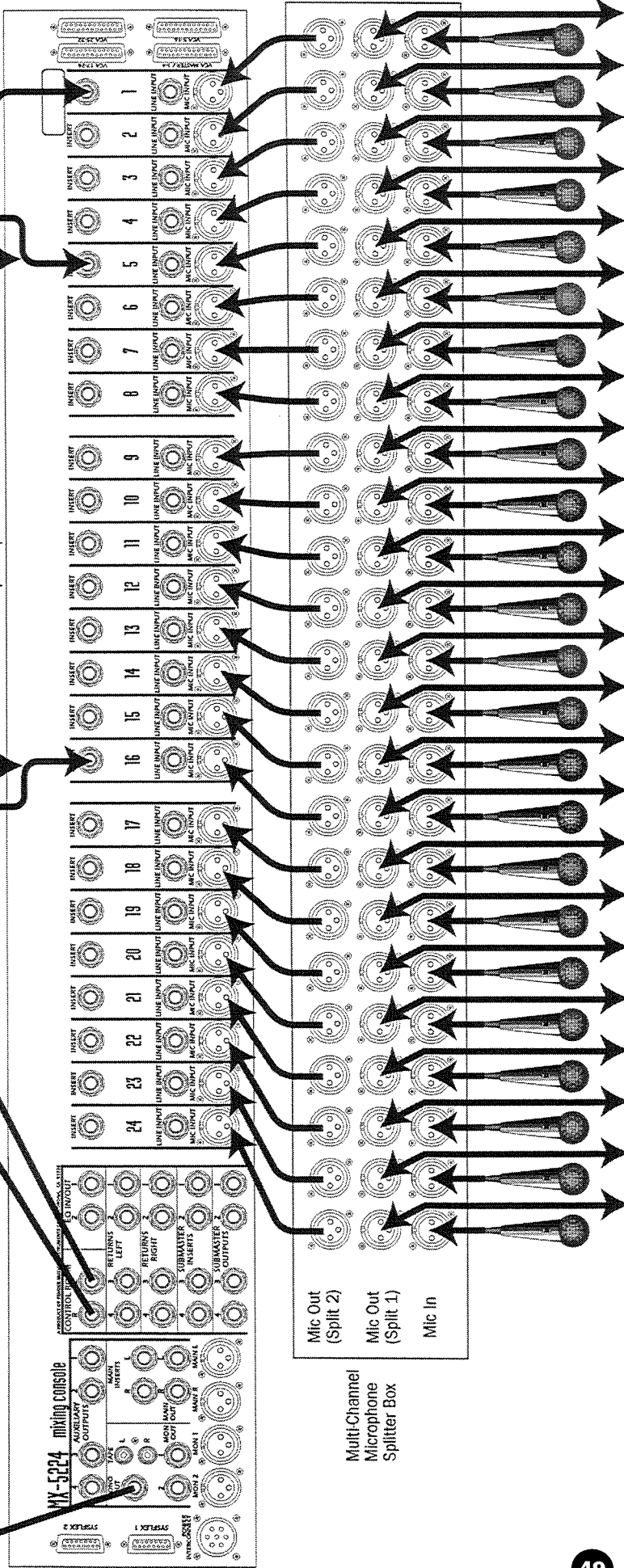

Split Output To The Onstage Monitor Mixing Console, Processing, Amplifiers, And Speakers. See Example 5 For Connection Details.

Notes

1. No effects-send buses or effects returns are used for special effects, although effects can be added.
2. Aux. Sends 3 and 4 are not used. They could be employed as additional monitor sends (if desired).
3. The internal "outboard" parametric equalizers are switched into the Monitor 1/2 position and are used like the M-300 controls (feedback and rolloff filters). Alternatively, they can be patched into individual inputs.
4. Except for the stereo sidefill stacks, all 1/3-octave graphic equalizers are used for tonal shaping, not feedback control. The M-300s are used for feedback control.
5. No limiters are required on monitor mixes 1 through 8, because the signal flows through the preamp/feedback control circuitry/filters/and DeltaComp™ (compressor/limiter) section of the M-300 before being amplified.
6. All Aux. Sends (1 through 4) and Monitor Sends (1 and 2) are switched/jumpered to be post-EQ and post-fader.

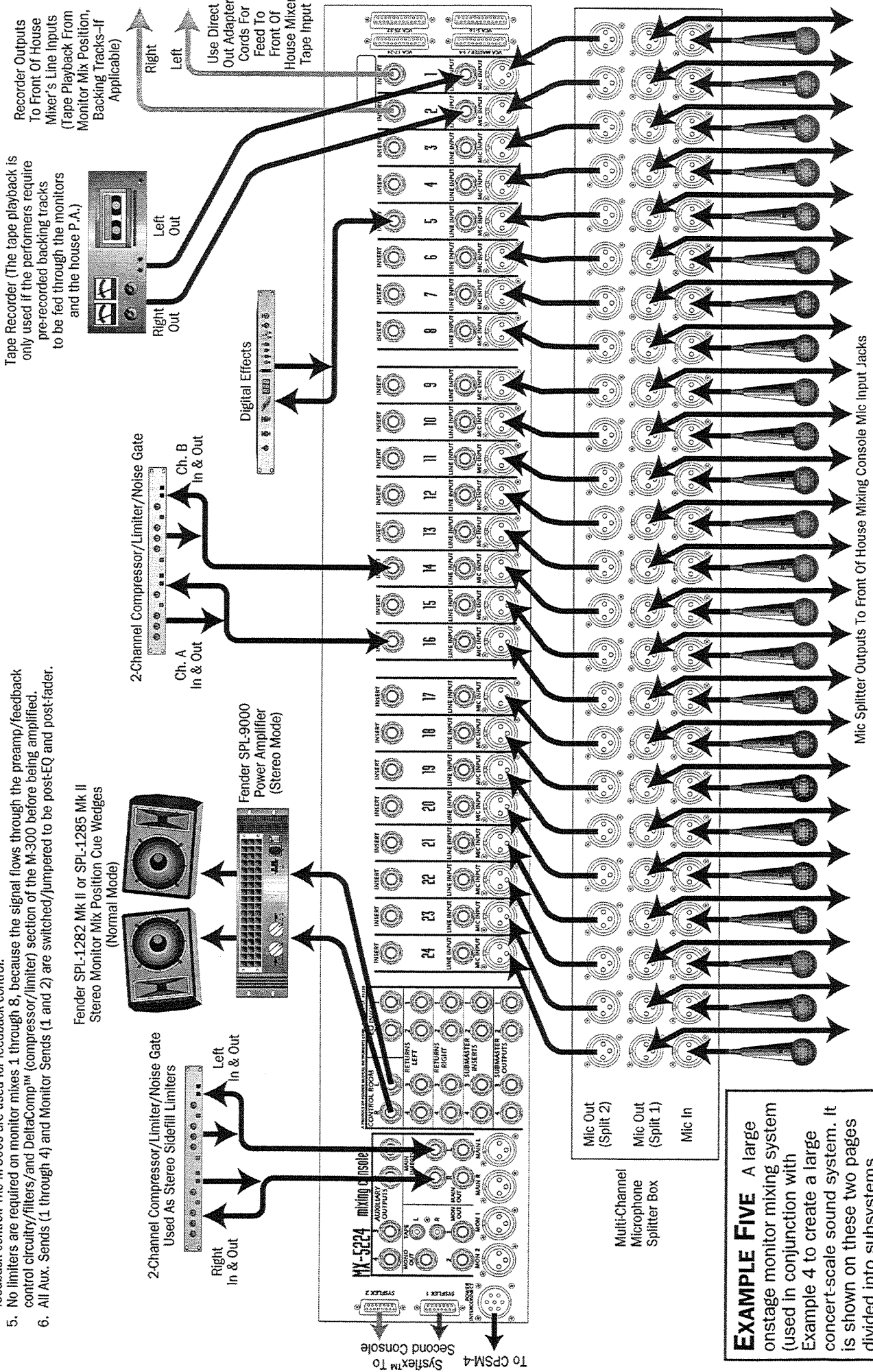

EXAMPLE FIVE A large onstage monitor mixing system (used in conjunction with Example 4) to create a large concert-scale sound system. It is shown on these two pages divided into subsystems.

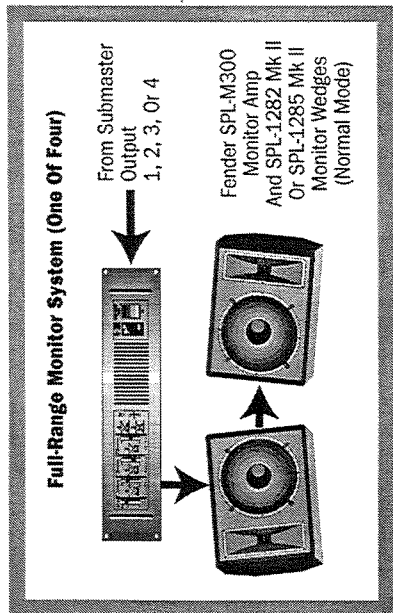
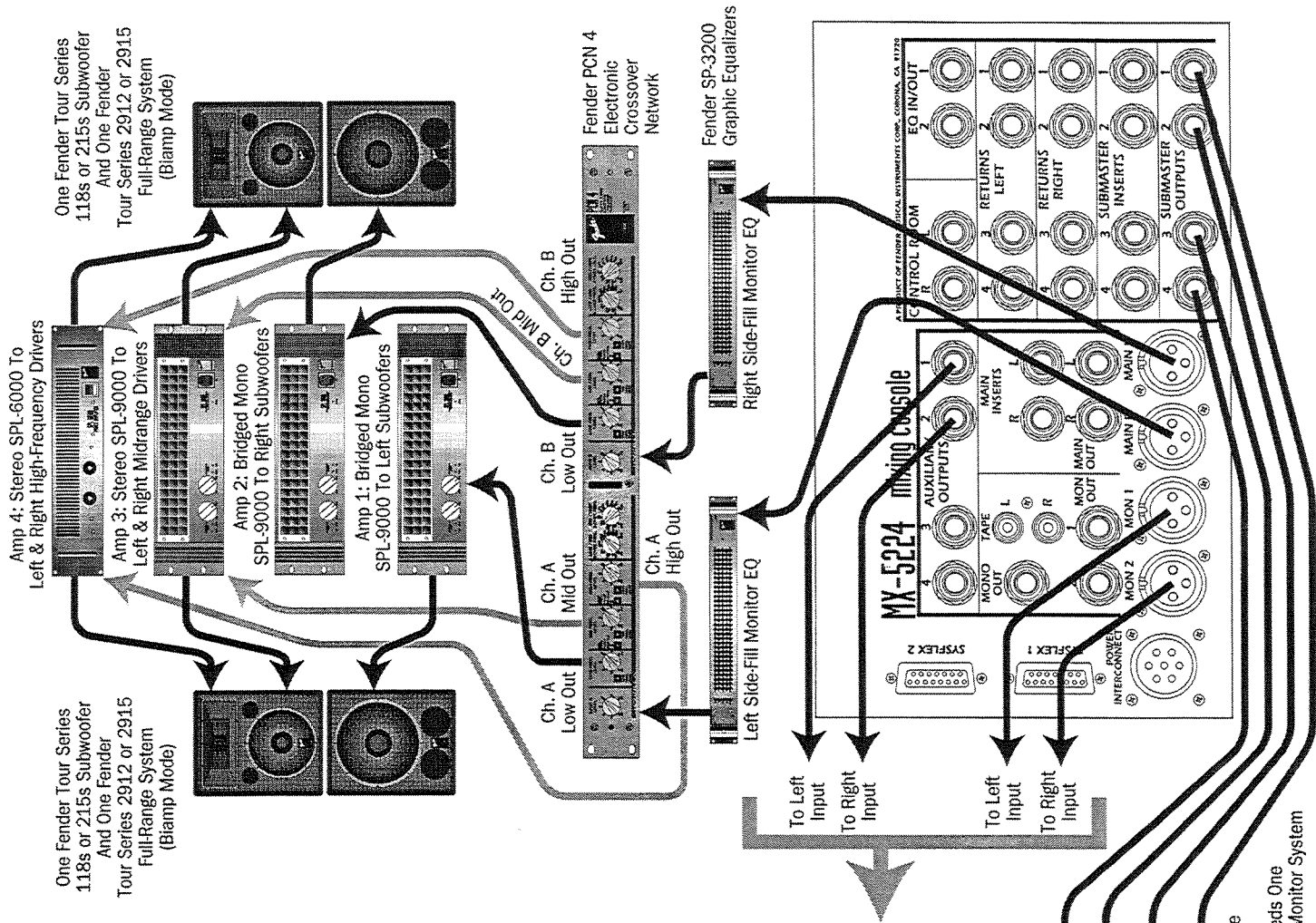
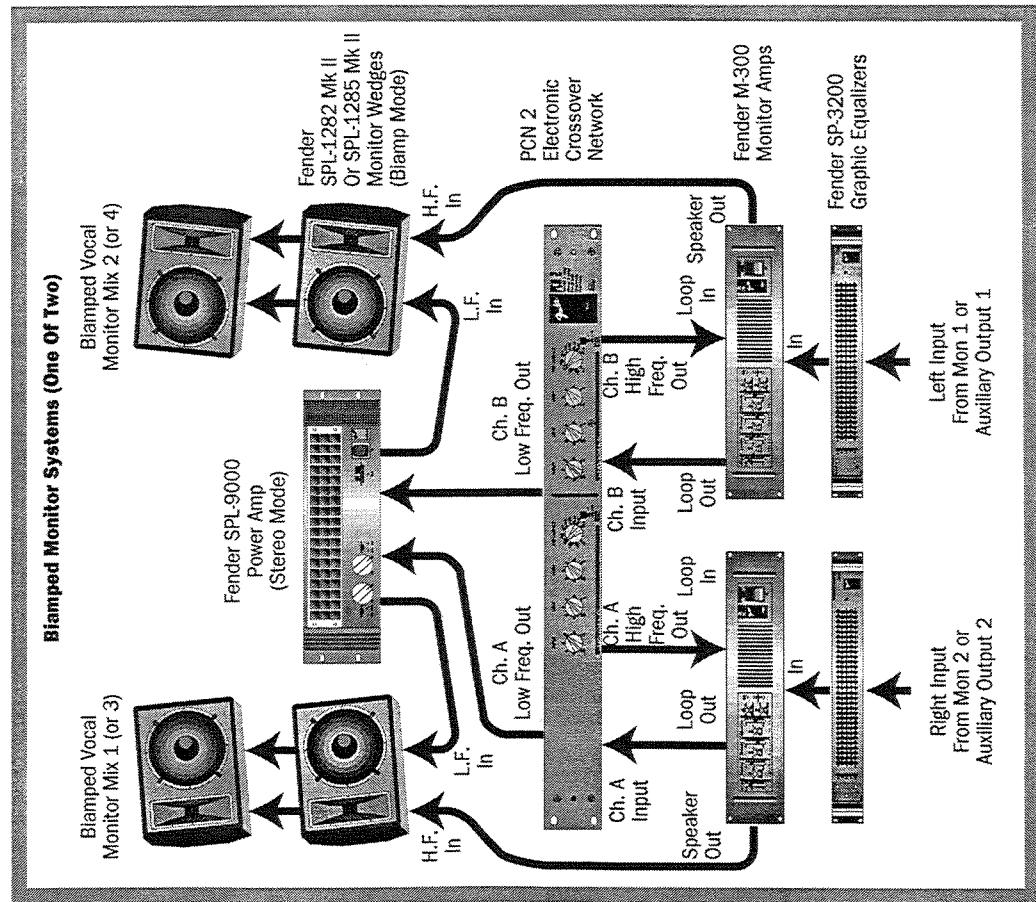

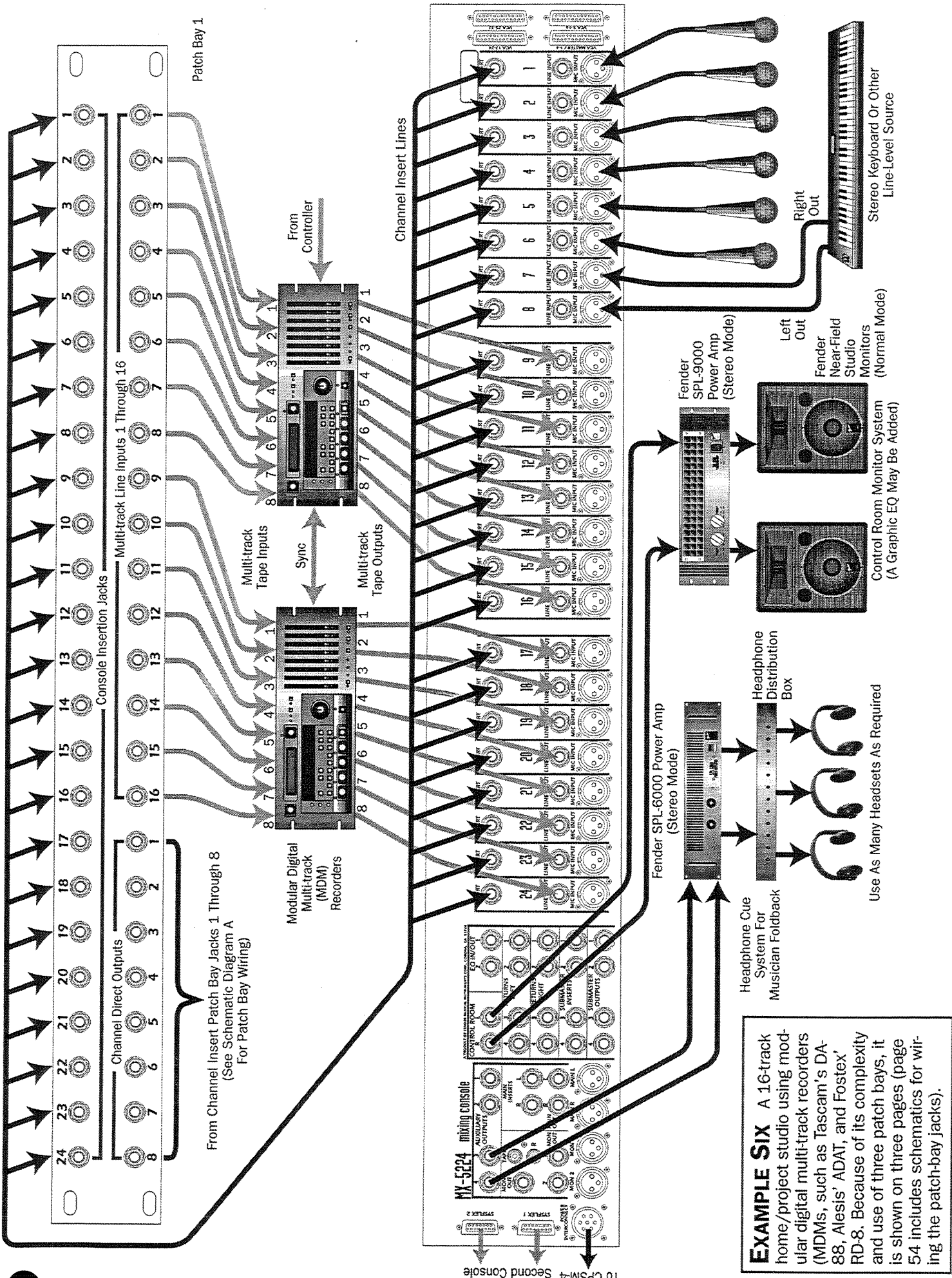

EXAMPLE SIX A 16-track home/project studio using modular digital multi-track recorders (MDMs), such as Tascam's DA-88, Alesis' ADAT, and Fostex' RD-8. Because of its complexity and use of three patch bays, it is shown on three pages (page 54 includes schematics for wiring the patch-bay jacks).

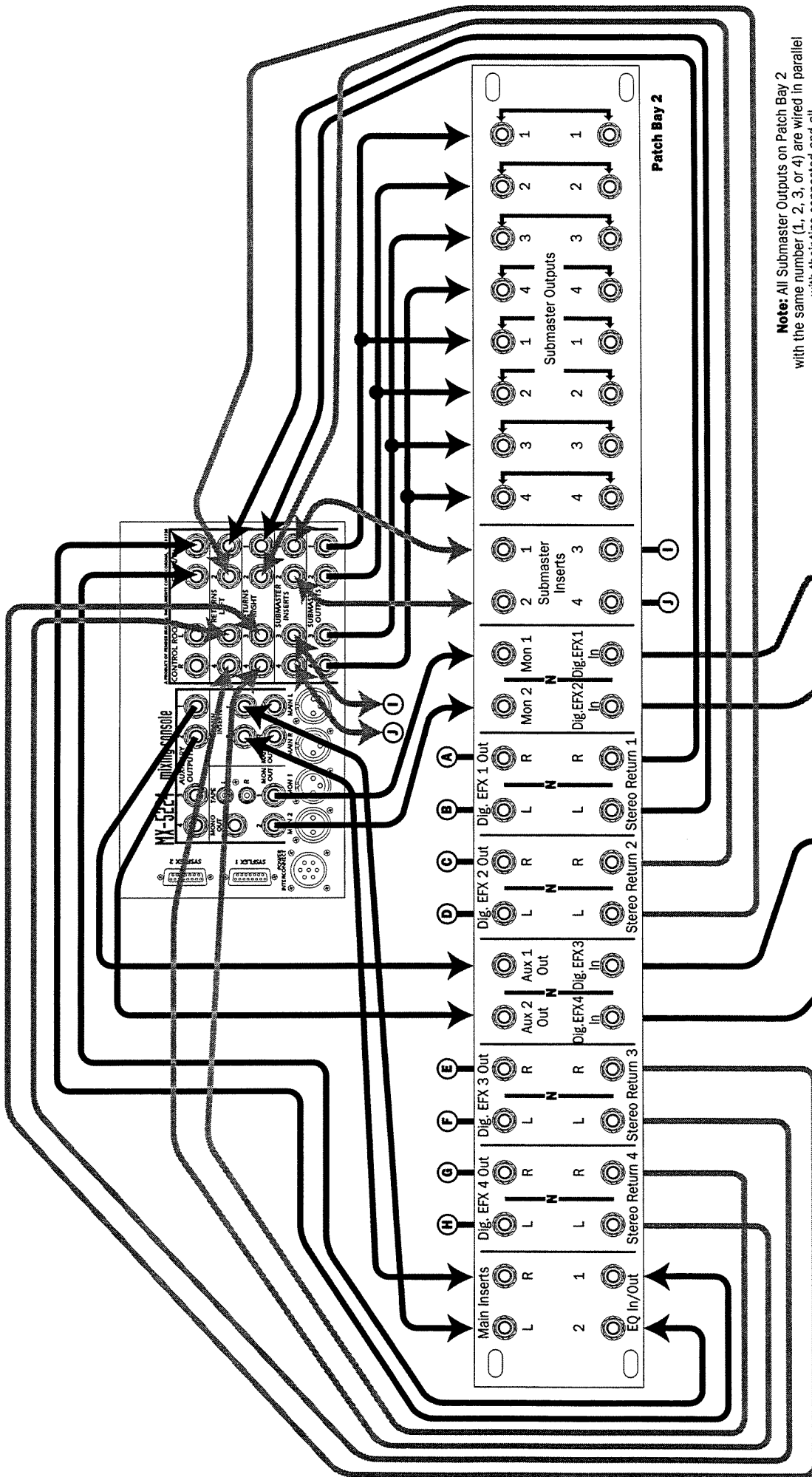

Note: All Submaster Outputs on Patch Bay 2 with the same number (1, 2, 3, or 4) are wired in parallel with their tips connected and all sleeves connected; rings are not connected.

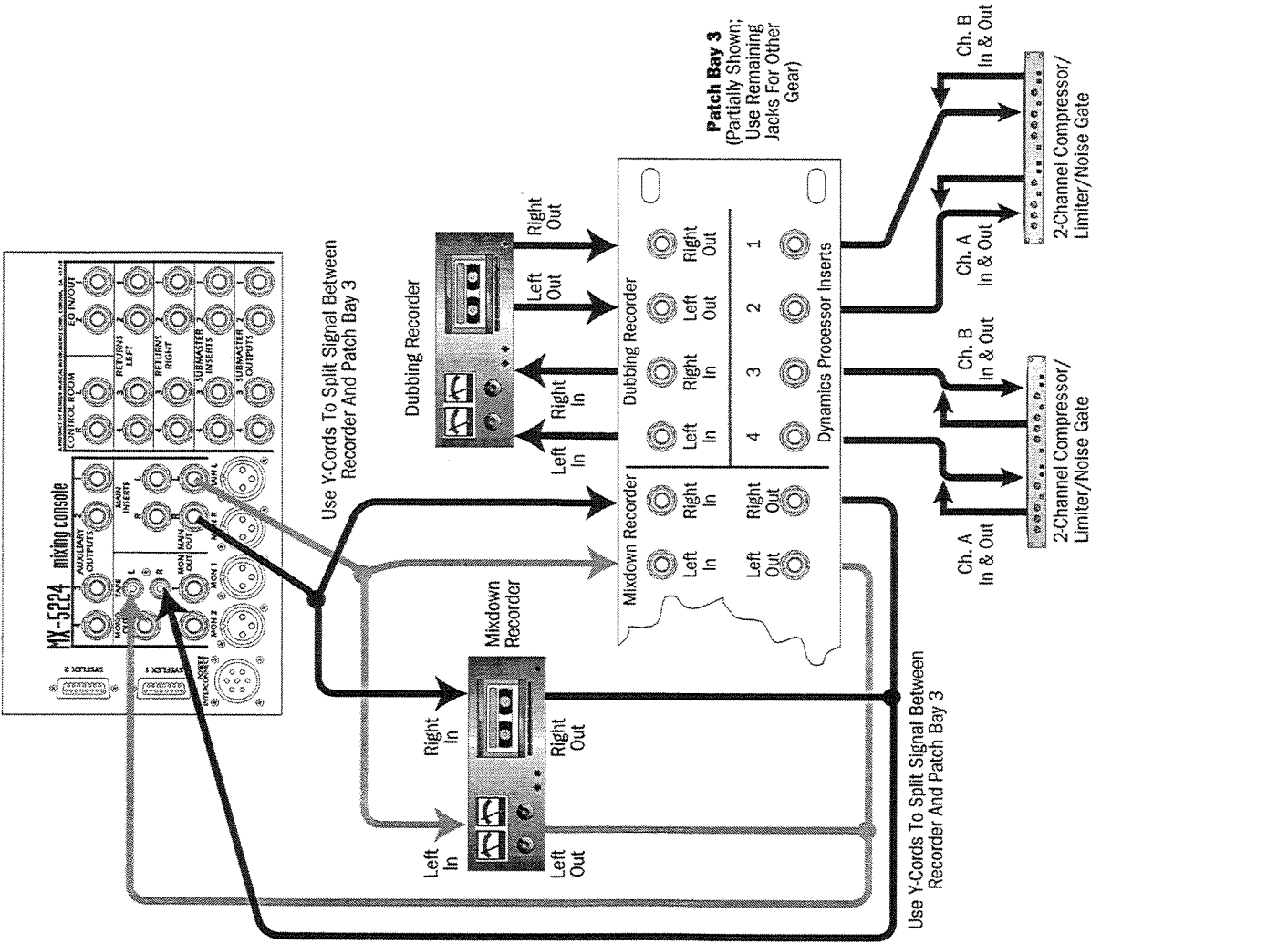
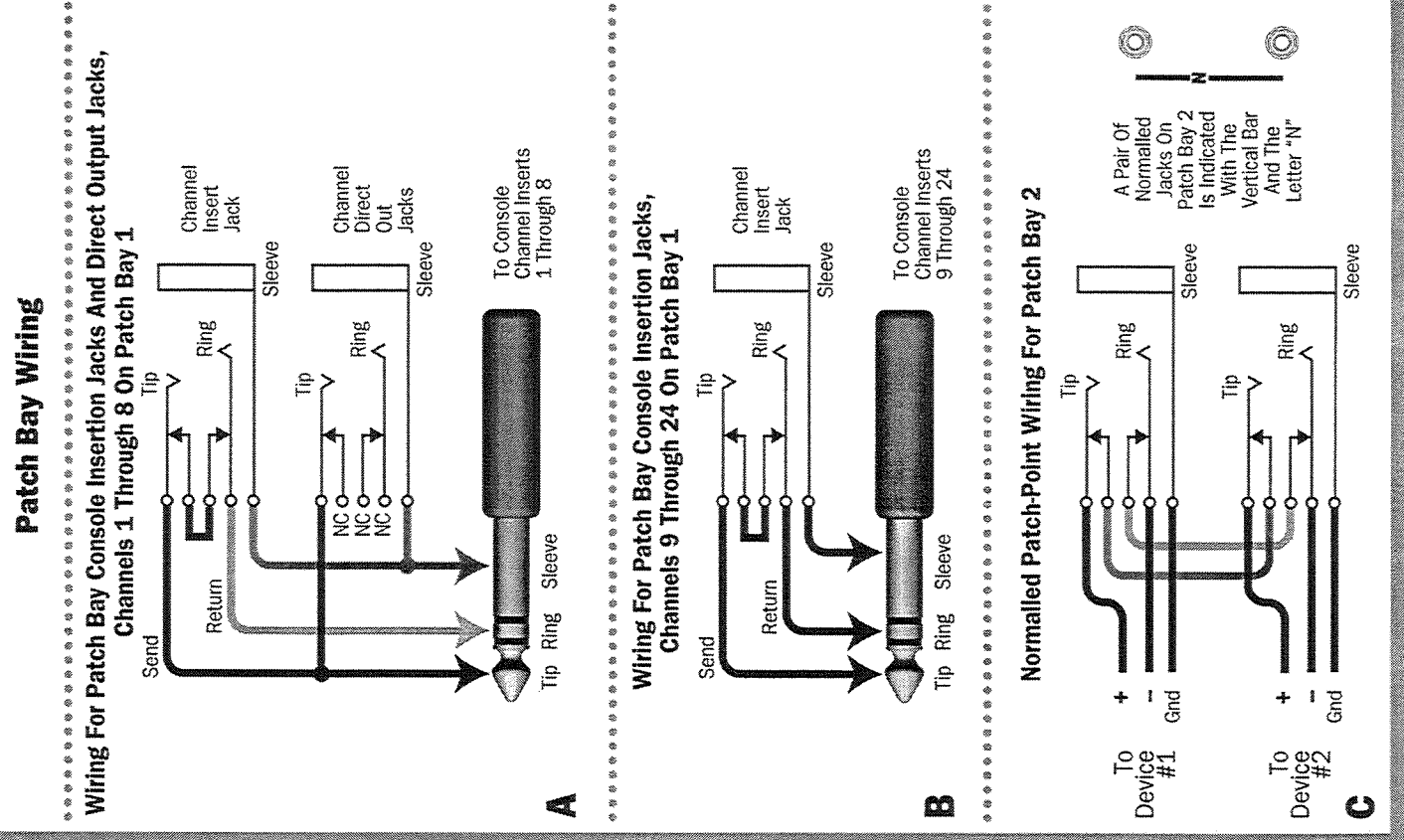

NOTES

NOTES



NOTES

