



XDCPA9BT

QUICK START GUIDE

Multimedia Receiver with Android Auto™ and CarPlay™ featuring a 6.95" digital TFT LCD

This Quick Start Guide gives you the basics to start using your XDCPA9BT. Please visit www.dualav.com/support/manuals.php to download a complete owner's manual or call customer service at 1-866-382-5476 (Monday-Friday, 9AM-5PM EST).



Customer Service Toll Free: 1-866-382-5476

Wiring Diagram - Inputs/Outputs

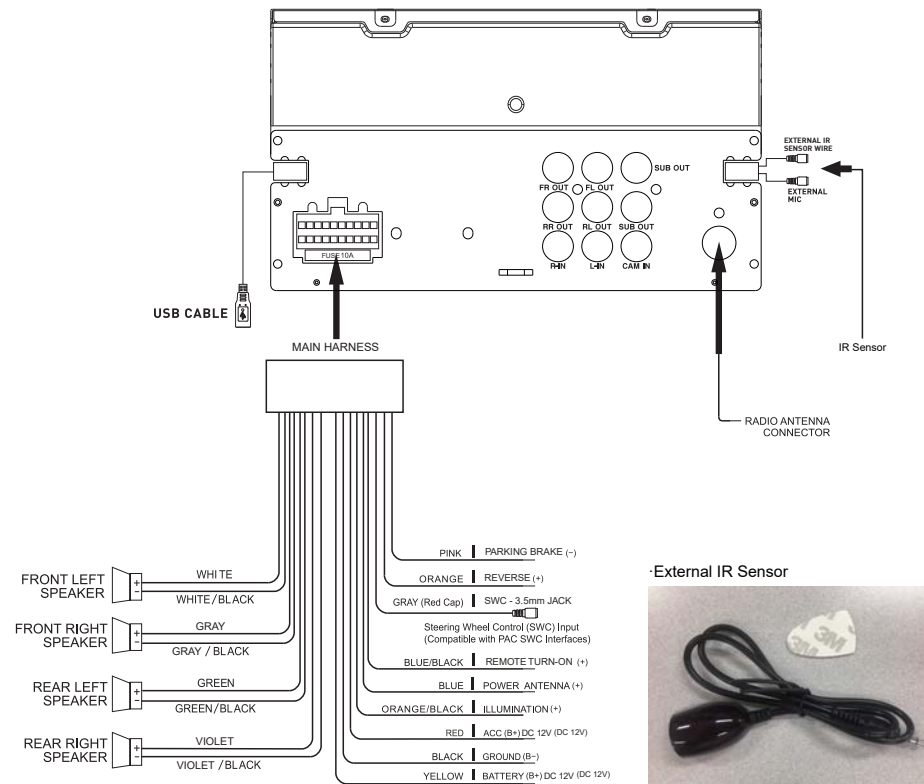

Control Locations



- 1. Mode
- 2. Power/Mute
- 3. Volume Up
- 4. Volume Down
- 5. MIC

Remote Control

For best performance we recommend mounting the remote control between the 3 o'clock and 6 o'clock positions on the steering wheel.

- 1. Volume Down
- 2. Volume Up
- 3. Mute
- 4. Tune/Track Up
- 5. Tune/Track Down

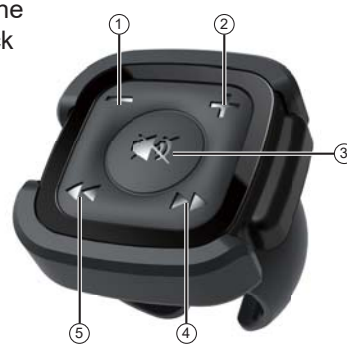

Main Menu

In the Menu mode, press the desired icon to enter the corresponding mode: Radio, USB, BT Phone, BT Music, Android Auto, CarPlay, iPod, Settings, AUX In, Rear Camera

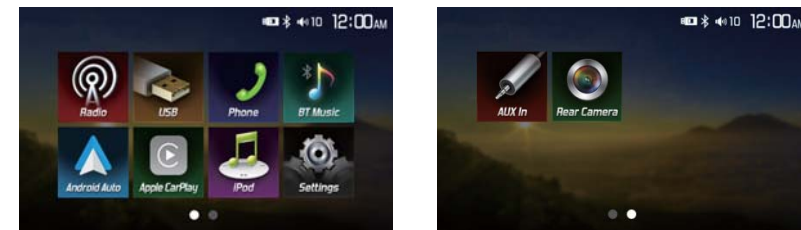

Tuner Operation

Select the Tuner icon from the Main Menu screen or press MODE until Tuner is selected.



- 1. LOC
- 2. Preset Scan
- 3. Presets
- 4. Seek Down
- 5. Manual Tune Down
- 6. Band/Auto Store
- 7. Manual Tune Up
- 8. Seek Up

USB Operation

Insert USB device in the USB slot, and the unit will read the USB device.

- 1. List
- 2. Repeat
- 3. Random
- 4. Track Down
- 5. Pause
- 6. Track Up



iPod Operation

To play MP3 files from an iPod, connect the device via USB and choose iPod from the Main Menu.

Note: The unit will automatically launch CarPlay any time a CarPlay enabled device is connected. To program the unit to launch in iPod mode instead, complete the following steps to disable CarPlay functionality from the iPhone

- 1. Remove the iPod cable from the unit if connected.
- 2. Enter the Settings of the iPhone and select General mode.
- 3. Select "Restrictions" in General mode (enter 0000 if a password is required).
- 4. Inactivate CarPlay.

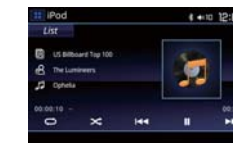

Note: Older devices such as iPod nano and Classic do not support CarPlay function. When they are connected to the unit, they will only work in iPod mode

General Operation

Touch the Sub-Menu feature to be adjusted.



- 1. System
- 2. Fader/Balance
- 3. Equalizer
- 4. Surround
- 5. Subwoofer
- 6. Display
- 7. Time Settings
- 8. Misc

Audio Operation

Press the Settings icon on the main menu screen to adjust Fader and Balance controls, Equalizer (10-Band Tone Control and 7 Presets EQ Settings) and Surround Modes.



CarPlay Operation

Select CarPlay on the Main Menu.

If the iPhone is connected via USB port, press CarPlay icon on main menu to mirror the iPhone's apps onto the screen. If the iPhone USB cable is inserted to the USB port then the XDCPA9BT will automatically change to CarPlay mode.

Please refer to on-line Owner's Manual for more details.

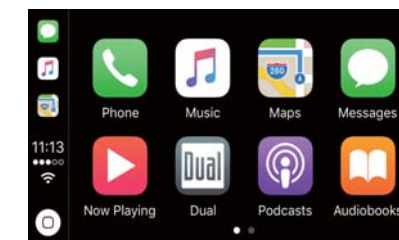

Android Auto Operation

Select Android Auto on the Main Menu.

If the Android Phone is connected via USB port, press Android Auto icon on main menu to mirror the Android Auto Basic Image onto the screen. If the Android Phone USB cable is inserted to the USB port then the XDCPA9BT will automatically change to Android Auto mode.

Please refer to on-line Owner's Manual for more details.

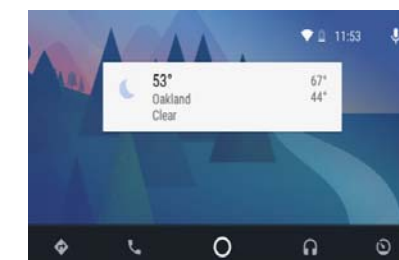

Bluetooth Operation

Bluetooth Microphone

The microphone is external and is included with the receiver.

Pairing and Connecting

Make sure that Bluetooth is activated on your device before you begin the pairing process. The unit broadcasts the pairing signal constantly when no devices are currently connected. Complete the pairing sequence from your Bluetooth device. The device name is "XDCPA9BT". The Bluetooth passcode is "0000". The unit can be in any mode of operation when pairing is performed. On certain phones, pairing may need to be done more than once.

Dialing a Number

Press # to display keypad and dial a number.

Making and Ending a Call

Press to connect a call, and press to end a call.

Transferring Audio

Press to transfer audio between the head unit and mobile phone.

Streaming Audio

Press to play or pause the music. Press to skip to the previous track. Press to advance to the next track.

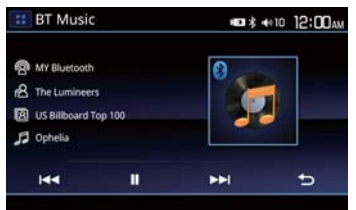
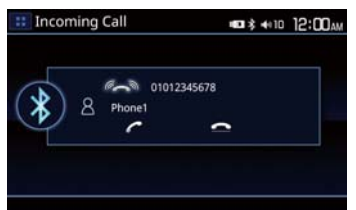
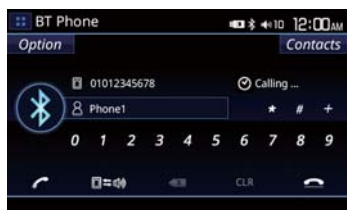

Copyright and Trademark Notes

The Bluetooth® word mark and logos are owned by the Bluetooth SIG, Inc. Use of the Apple CarPlay logo means that a vehicle user interface meets Apple performance standards. Apple is not responsible for the operation of this vehicle or its compliance with safety and regulatory standards. Please note that use of this product with iPhone, iPod or iPad may affect wireless performance. Apple CarPlay is a trademark of Apple Inc. "Made for iPod" and "Made for iPhone" mean that an electronic accessory has been designed to connect specifically to iPod or iPhone, respectively, and has been certified by the developer to meet Apple performance standards. iPhone and iPod are trademarks of Apple, Inc., registered in the U.S. and other countries. Other trademarks and trade names are those of their respective owners. Availability of Android Auto™ may vary depending upon your country and phone model. Please visit android.com/auto for more information. Android, Android Auto, Google and other marks are trademarks of Google Inc.

One-Year Limited Warranty

This warranty gives you specific legal rights. You may also have other rights which vary from state to state. Dual Electronics Corp. warrants this product to the original purchaser to be free from defects in material and workmanship for a period of one year from the date of the original purchase. Dual Electronics Corp. agrees, at our option, during the warranty period, to repair any defect in material or workmanship or to furnish an equal new, renewed or comparable product (whichever is deemed necessary) in exchange without charges, subject to verification of the defect or malfunction and proof of the date of purchase. Subsequent replacement products are warranted for the balance of the original warranty period. Who is covered? This warranty is extended to the original retail purchaser for products purchased from an authorized Dual dealer and used in the U.S.A. What is covered? This warranty covers all defects in material and workmanship in this product. The following are not covered: software, installation/removal costs, damage resulting from accident, misuse, abuse, neglect, product modification, improper installation, incorrect line voltage, unauthorized repair or failure to follow instructions supplied with the product, or damage occurring during return shipment of the product. Specific license conditions and copyright notices for the software can be found via www.dualav.com.

What to do?

- 1. Before you call for service, check the troubleshooting guide in your owner's manual. A slight adjustment of any custom controls may save you a service call.
 - 2. If you require service during the warranty period, you must carefully pack the product (preferably in the original package) and ship it by prepaid transportation with a copy of the original receipt from the retailer to an authorized service center.
 - 3. Please describe your problem in writing and include your name, a return UPS shipping address (P.O. Box not acceptable), and a daytime phone number with your shipment.
 - 4. For more information and for the location of the nearest authorized service center please contact us by one of the following methods:
 - Call us toll-free at 1-866-382-5476 (Monday-Friday, 9:00 a.m. to 5:00 p.m. EST)
 - E-mail us at cs@dualav.com
- Exclusion of Certain Damages: This warranty is exclusive and in lieu of any and all other warranties, expressed or implied, including without limitation the implied warranties of merchantability and fitness for a particular purpose and any obligation, liability, right, claim or remedy in contract or tort, whether or not arising from the company's negligence, actual or imputed. No person or representative is authorized to assume for the company any other liability in connection with the sale of this product. In no event shall the company be liable for indirect, incidental or consequential damages.

FCC Compliance

This device complies with Part 15 of the FCC Rules. Operation is subject to the following two conditions: (1) this device may not cause harmful interference, and (2) this device must accept any interference received, including interference that may cause undesired operation. **Warning:** Changes or modifications to this unit not expressly approved by the party responsible for compliance could void the user's authority to operate the equipment. **Note:** This equipment has been tested and found to comply with the limits for a Class B digital device, pursuant to Part 15 of the FCC Rules. These limits are designed to provide reasonable protection against harmful interference in a residential installation. This equipment generates, uses and can radiate radio frequency energy and, if not installed and used in accordance with the instructions, may cause harmful interference to radio communications. However, there is no guarantee that interference will not occur in a particular installation. If this equipment does cause harmful interference to radio or television reception, which can be determined by turning the equipment off and on, the user is encouraged to try to correct the interference by one or more of the following measures:

- Reorient or relocate the receiving antenna.
- Increase the separation between the equipment and receiver.
- Connect the equipment into an outlet on a circuit different from that to which the receiver is connected.
- Consult the dealer or an experienced radio/TV technician for help.

www.dualav.com
©2018 Dual Electronics Corp.
NSC0618-V01
Printed in China

Note: Make sure a certified Apple Lightning cable is used to connect your iPhone to the receiver.

SAFETY NOTICE

Upon installation of this Monitor/DVD/Bluetooth ("unit") into a vehicle, the driver of the vehicle must not operate this unit by watching movies, videos, or playing video games while driving. Many states prohibit cell phone operation while the vehicle is in operation. Check <https://www.ghsa.org/> if you reside in a jurisdiction which has enacted such a law, this unit must be operated in accordance of your local jurisdiction. This unit includes a parking brake lock-out safety feature which prohibits the unit's video function(s) from operating if the vehicle is not in "Park" and/or the parking brake is not fully engaged. When installing this unit, the installer fully understands and agrees to correctly connect the parking brake detect wire ("Pink Lead") to the vehicles parking brake electronic mechanism in order to fully enable the parking brake lock-out feature. DO NOT ground the parking brake detect wire to a metal portion of the vehicle. Once the parking brake lock-out feature is installed, the owner/user must not attempt to disrupt/neutralize the parking brake lock-out feature by (a) partially engaging the parking brake and/or (b) purchasing/using any device or unit designed to circumvent the safety lock-out function. When operating this unit, keep the unit's volume level low enough so that the vehicle's occupants can hear traffic-related sounds such as police and emergency vehicles. Failure to follow these instructions could lead to driver distraction, which could result in serious injury, or death.

Installation

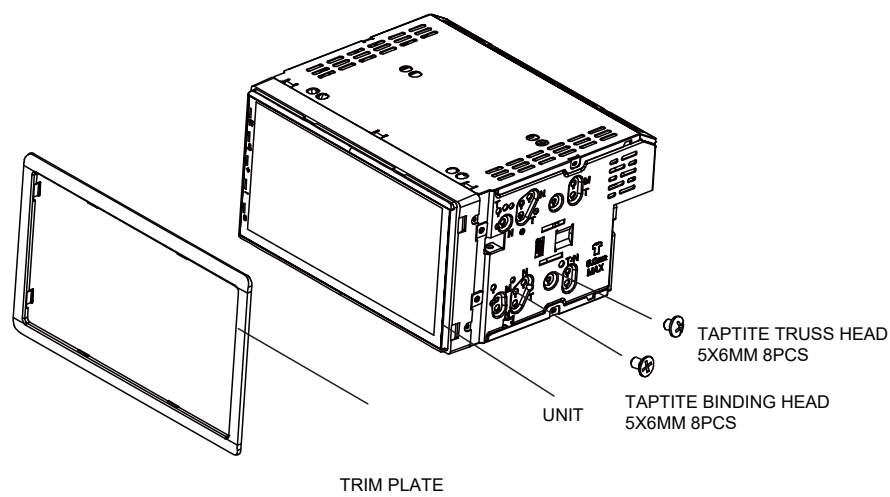

TYPICAL FRONT-LOAD MOUNTING METHOD