



Perfect Wireless Experience  
完美无线体验

# L830-EB-11 Hardware User Manual

Version: V1.0.2

Update date: 2017.09.21



## Applicability Table

No.	Product model	Description
1	L830-EB-11	NA

## Copyright

Copyright © 2017 Fibocom Wireless Inc. All rights reserved.

Without the prior written permission of the copyright holder, any company or individual is prohibited to excerpt, copy any part of or the entire document, or distribute the document in any form.

## Notice

The document is subject to update from time to time owing to the product version upgrade or other reasons. Unless otherwise specified, the document only serves as the user guide. All the statements, information and suggestions contained in the document do not constitute any explicit or implicit guarantee.

## Version Record

Version	Update	Remark
V1.0.0	2017.04.25	Initial version
V1.0.1	2017-09-21	<ol style="list-style-type: none"><li>1. Update timing of power on/off and reset</li><li>2. Modify the RF Band</li><li>3. Modify the packing description</li></ol>

# Contents

<b>1 Preface</b> .....	<b>6</b>
1.1 Introduction.....	6
1.2 Reference Standard.....	6
1.3 Related Documents.....	6
<b>2 Overview</b> .....	<b>7</b>
2.1 Introduction.....	7
2.2 Specification.....	7
2.3 Application Framework.....	8
2.4 Hardware Framework.....	9
<b>3 Application Interface</b> .....	<b>9</b>
3.1 M.2 Interface.....	9
3.1.1 <i>Pin Map</i> .....	10
3.1.2 <i>Pin Definition</i> .....	11
3.2 Power Supply.....	14
3.2.1 <i>Power Supply</i> .....	15
3.2.2 <i>Logic level</i> .....	16
3.2.3 <i>Power Consumption</i> .....	16
3.3 Control Signal.....	17
3.3.1 <i>Module Start-Up</i> .....	17
3.3.1.1 Start-up Circuit.....	17
3.3.1.2 Start-up Timing Sequence.....	18
3.3.2 <i>Module Shutdown</i> .....	19
3.3.3 <i>Module Reset</i> .....	20
3.4 USB Interface.....	21
3.4.1 <i>USB Interface Definition</i> .....	21
3.4.2 <i>USB Interface Application</i> .....	21
3.5 USIM Interface.....	22
3.5.1 <i>USIM Pins</i> .....	22
3.5.2 <i>USIM Interface Circuit</i> .....	23
3.5.2.1 N.C. SIM Card Slot.....	23
3.5.2.2 N.O. SIM Card Slot.....	23
3.5.3 <i>USIM Hot-Plugging</i> .....	24

3.5.4	<i>USIM Design</i> .....	25
3.6	Status Indicator.....	25
3.6.1	<i>LED#1 Signal</i> .....	26
3.6.2	<i>WOWWAN#</i> .....	26
3.7	Interrupt Control.....	27
3.7.1	<i>W_DISABLE1#</i> .....	27
3.7.2	<i>Body SAR</i> .....	28
3.8	Digital Audio.....	28
3.8.1	<i>I2S Mode</i> .....	28
3.8.2	<i>PCM Mode</i> .....	29
3.9	I2C Interface Description.....	29
3.10	Clock Interface.....	30
3.11	Configuration Interface.....	30
3.12	Other Interfaces.....	31
4	Radio Frequency.....	31
4.1	RF Interface.....	31
4.1.1	<i>RF Interface Functionality</i> .....	31
4.1.2	<i>RF Connector Characteristic</i> .....	31
4.1.3	<i>RF Connector Dimension</i> .....	32
4.2	Operating Band.....	33
4.3	Transmitting Power.....	33
4.4	Receiver Sensitivity.....	33
4.5	GNSS.....	34
4.6	Antenna Design.....	34
5	Structure Specification.....	35
5.1	Product Appearance.....	35
5.2	Dimension of Structure.....	35
5.3	M.2 Interface Model.....	36
5.4	M.2 Connector.....	37
5.5	Storage.....	37
5.5.1	<i>Storage Life</i> .....	37
5.6	Packing.....	37
5.6.1	<i>Tray Package</i> .....	38
5.6.2	<i>Tray size</i> .....	39

# 1 Preface

## 1.1 Introduction

The document describes the electrical characteristics, RF performance, dimensions and application environment, etc. of L830-EB (hereinafter referred to as L830). With the assistance of the document and other instructions, the developers can quickly understand the hardware functions of L830 modules and develop products.

## 1.2 Reference Standard

The design of the product complies with the following standards:

- 3GPP TS 34.121-1 V10.8.0: User Equipment (UE) conformance specification; Radio transmission and reception (FDD); Part 1: Conformance specification
- 3GPP TS 36.521-1 V10.6.0: User Equipment (UE) conformance specification; Radio transmission and reception; Part 1: Conformance testing
- 3GPP TS 21.111 V10.0.0: USIM and IC card requirements
- 3GPP TS 51.011 V4.15.0: Specification of the Subscriber Identity Module -Mobile Equipment (SIM-ME) interface
- 3GPP TS 31.102 V10.11.0: Characteristics of the Universal Subscriber Identity Module (USIM) application
- 3GPP TS 31.11 V10.16.0: Universal Subscriber Identity Module (USIM) Application Toolkit(USAT)
- 3GPP TS 36.124 V10.3.0: ElectroMagnetic Compatibility (EMC) requirements for mobile terminals and ancillary equipment
- 3GPP TS 27.007 V10.0.8: AT command set for User Equipment (UE)
- PCI\_Express\_M.2\_Specification\_Rev1.1

## 1.3 Related Documents

- RF Antenna Application Design Specification
- L8-Family System Driver Integration and Application Guidance
- L8-Family AT Commands Manual

## EU Regulator Conformance

Hereby, We, Fibocom Wireless Inc. declares that the radio equipment type L830-EB-11 is in compliance with the Directive 2014/53/EU.

In all cases assessment of the final product must be mass against the Essential requirements of the Directive 2014/53/EU Article 3.1(a) and (b), safety and EMC respectively, as well as any relevant Article 3.2 requirements.

External antenna is used with the module during the testing process, the maximum antenna gain for frequency < 1G is 3dBi, for frequency > 1G is 5dBi and the antenna separation distance is 20cm.

## EU Declaration of Conformity (DoC)

Hereby,

Name of manufacturer: Fibocom Wireless Inc.  
Address: 5/F, Tower A, Technology Building II, 1057 Nanhai Blvd,  
Nanshan,  
City: Shenzhen,  
Country: China

**declares that the DoC is issued under its sole responsibility and that this product:**

Product description: LTE module  
Type designation(s): L830-EB-11  
Trademark: Fibocom  
Product Identification  
Element L830-EB-11

**is in conformity with the relevant Union harmonization legislation:**

Radio Equipment directive: **2014 / 53 / EU.**

**with reference to the following standards applied:**

### 1. Health (Article 3.1(a) of Directive 2014/53/EU)

Applied Standard(s):

- EN 62311 : 2008

### 2. Safety (Article 3.1(a) of Directive 2014/53/EU)

Applied Standard(s):

- EN 60950-1: 2006 + A11: 2009 + A1: 2010 + A12: 2011 + A2: 2013

### 3. Electromagnetic compatibility (Article 3.1 (b) of Directive 2014/53/EU)

Applied Standard(s):

- Draft EN 301 489-1 V2.2.0 / -52 V1.1.0

### 4. Radio frequency spectrum usage (Article 3.2 of Directive 2014/53/EU)

Applied Standard(s):

- EN 301 908-1 V11.1.1 / -2 V11.1.1 / -13 V11.1.1

**The Notified Body SIEMIC INC. with Notified Body number 2200 performed:**

*Modules: B+C and issued the EU-type examination certificate.*

**Signed for and on behalf of:**

Date: September 7, 2017  
City: Shenzhen,  
Name: Alan Yu  
Title: Test Director  
Signature: 

## **Federal Communication Commission Interference Statement**

This device complies with Part 15 of the FCC Rules. Operation is subject to the following two conditions: (1) This device may not cause harmful interference, and (2) this device must accept any interference received, including interference that may cause undesired operation.

This equipment has been tested and found to comply with the limits for a Class B digital device, pursuant to Part 15 of the FCC Rules. These limits are designed to provide reasonable protection against harmful interference in a residential installation. This equipment generates, uses and can radiate radio frequency energy and, if not installed and used in accordance with the instructions, may cause harmful interference to radio communications. However, there is no guarantee that interference will not occur in a particular installation. If this equipment does cause harmful interference to radio or television reception, which can be determined by turning the equipment off and on, the user is encouraged to try to correct the interference by one of the following measures:

- Reorient or relocate the receiving antenna.
- Increase the separation between the equipment and receiver.
- Connect the equipment into an outlet on a circuit different from that to which the receiver is connected.
- Consult the dealer or an experienced radio/TV technician for help.

### **FCC Caution:**

- Any changes or modifications not expressly approved by the party responsible for compliance could void the user's authority to operate this equipment.
- This transmitter must not be co-located or operating in conjunction with any other antenna or transmitter.



**Radiation Exposure Statement:**

This equipment complies with FCC radiation exposure limits set forth for an uncontrolled environment. This equipment should be installed and operated with minimum distance 20cm between the radiator & your body.

**This device is intended only for OEM integrators under the following conditions:**

- 1) External antenna is used with the module during the testing process, the maximum antenna gain for frequency >1G is 5 dBi and the antenna separation distance is 20cm.
- 2) The transmitter module may not be co-located with any other transmitter or antenna.

As long as 2 conditions above are met, further transmitter test will not be required. However, the OEM integrator is still responsible for testing their end-product for any additional compliance requirements required with this module installed

**IMPORTANT NOTE:** In the event that these conditions can not be met (for example certain laptop configurations or co-location with another transmitter), then the FCC authorization is no longer considered valid and the FCC ID can not be used on the final product. In these circumstances, the OEM integrator will be responsible for re-evaluating the end product (including the transmitter) and obtaining a separate FCC authorization.

**End Product Labeling**

This transmitter module is authorized only for use in device where the antenna may be installed such that 20 cm may be maintained between the antenna and users. The final end product must be labeled in a visible area with the following: **Contains FCC ID:** ZMOL830EB11  
The grantee's FCC ID can be used only when all FCC compliance requirements are met.

**Manual Information To the End User**

The OEM integrator has to be aware not to provide information to the end user regarding how to install or remove this RF module in the user's manual of the end product which integrates this module. The end user manual shall include all required regulatory information/warning as show in this manual.

## 2 Overview

### 2.1 Introduction

The L830 is a highly integrated 4G cellular module which uses the standard PCIe M.2 interface. It supports LTE FDD/WCDMA mode cellular communication.

### 2.2 Specification

Specification		
Operating Band	LTE FDD: Band 1,3,7,8,20,28,32	
	WCDMA/HSPA+: Band I, VIII	
	GPS/GLONASS: Not Support	
CA	LTE inter-band CA	1 +3,7,20
		3 +7,8,20,28,32
		7 +20,28
	LTE intra-band CA	3,7
Data Transmission	LTE FDD	300Mbps DL/50Mbps UL(Cat 6)
	UMTS/HSPA+	UMTS:384 kbps DL/384 kbps UL
		DC-HSDPA+:42Mbps DL(Cat 24)/5.76Mbps UL(Cat6)
Power Supply	DC 3.135V~4.4V, Typical 3.3V	
Temperature	Normal Operating temperature: -10°C ~+55°C	
	Extended Operating temperature: -30°C ~+65°C	
	Storage temperature: -40°C ~+85°C	
Physical characteristics	Interface: M.2 Key-B	
	Dimension: 30 x 42 x 2.3mm	
	Weight: About 5.8 g	
Interface		
Antenna Connector	WWAN Main Antenna x 1	
	WWAN Diversity Antenna x 1	
Function Interface	USIM 3V/1.8V	

	USB 2.0 x 1
	I2S
	I2C
	EINT、System Indicator
	Clock
<b>Software</b>	
Protocol Stack	IPV4/IPV6
AT commands	3GPP TS 27.007 and 27.005, and proprietary FIBOCOM AT commands
Firmware update	USB



**Note:**

When temperature goes beyond normal operating temperature range of -10°C~+55°C, RF performance of module may be slightly off 3GPP specifications.

## 2.3 Application Framework

The peripheral applications for L830 module are shown in Figure 2-1:

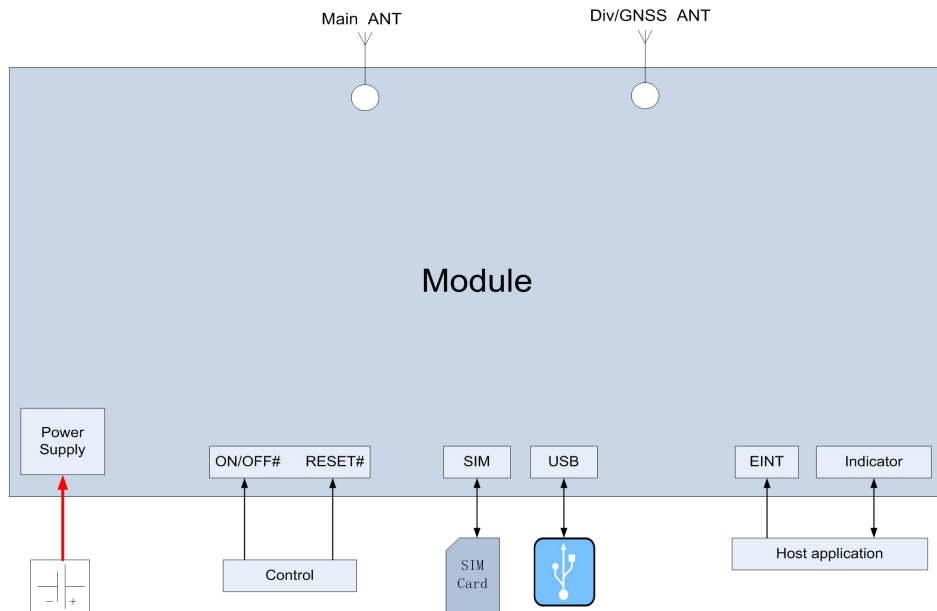

Figure2-1 Application Framework

## 2.4 Hardware Framework

The hardware framework in Figure 2-2 shows the main hardware functions of L830 module, including baseband and RF functions.

Baseband contains the followings:

- UMTS/LTE FDD controller/Power supply
- NAND/internal LPDDR2 RAM
- Application interface

RF contains the followings:

- RF Transceiver
- RF Power/PA
- RF Front end
- RF Filter
- Antenna Connector

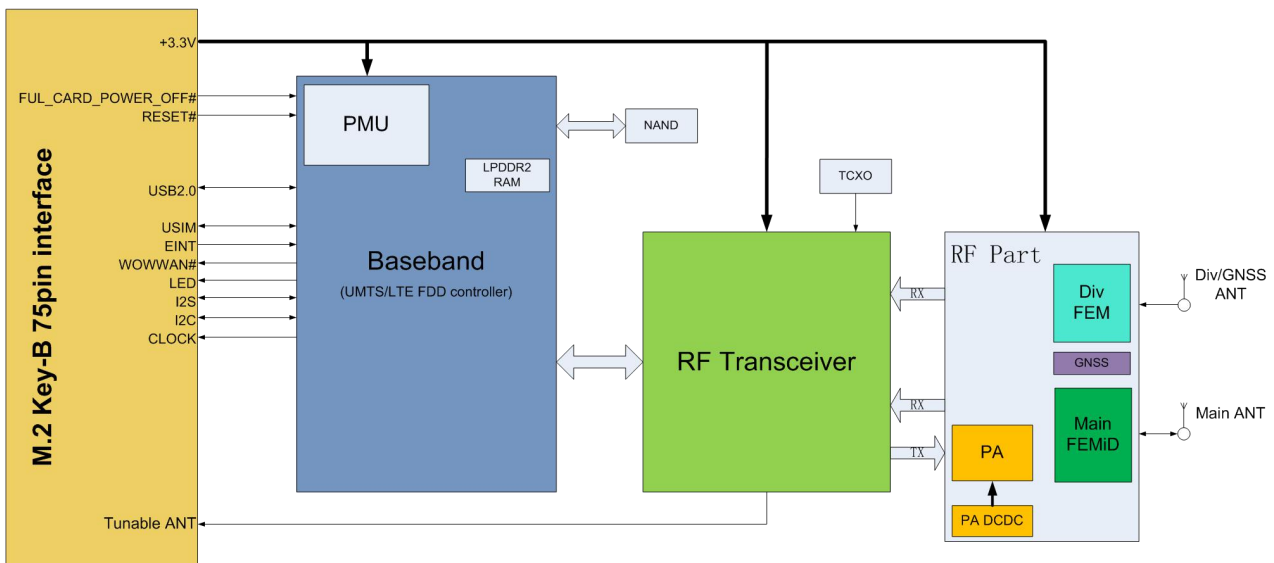

Figure 2-2 Hardware Framework

## 3 Application Interface

### 3.1 M.2 Interface

The L830 module uses standard M.2 Key-B interface, with a total of 75 pins.

### 3.1.1 Pin Map

74	+3.3V	CONFIG_2	75
72	+3.3V	GND	73
70	+3.3V	GND	71
68	NC	CONFIG_1	69
66	SIM_DETECT	RESET#	67
64	COEX1	ANTCTL3	65
62	COEX2	ANTCTL2	63
60	COEX3	ANTCTL1	61
58	NC	ANTCTL0	59
56	NC	GND	57
54	NC	NC	55
52	NC	NC	53
50	NC	GND	51
48	TX_BLANKING	NC	49
46	SYSCLK	NC	47
44	GNSS_IRQ	GND	45
42	GNSS_SDA	NC	43
40	GNSS_SCL	NC	41
38	NC	GND	39
36	UIM_PWR	NC	37
34	UIM_DATA	NC	35
32	UIM_CLK	GND	33
30	UIM_RESET	NC	31
28	I2S_WA	NC	29
26	W_DISABLE2#	GND	27
24	I2S_TX	DPR	25
22	I2S_RX	WOWWAN#	23
20	I2S_CLK	CONFIG_0	21
	Notch	Notch	
	Notch	Notch	
	Notch	Notch	
	Notch	Notch	
		GND	11
10	LED1#(3.3V)	USB D-	9
8	W_DISABLE1#(3.3V)	USB D+	7
6	FULL_CARD_POWER_OFF#(3.3/1.8V)	GND	5
4	+3.3V	GND	3
2	+3.3V	CONFIG_3	1

Figure 3-1 Pin Map



**Note:**

Pin “Notch” represents the gap of the gold fingers.

### 3.1.2 Pin Definition

The pin definition is as follows:

Pin	Pin Name	I/O	Reset Value	Pin Description	Type
1	CONFIG_3	O	L	Connected to internal GND, L830 M.2 module is configured as the WWAN-SSIC 0 interface type.	
2	+3.3V	PI		Module main power input.	Power Supply
3	GND			GND	Power Supply
4	+3.3V	PI		Module main power input.	Power Supply
5	GND			GND	Power Supply
6	FULL_CARD_POWER_OFF#	I		Power on/off control signal, active High.	CMOS 3.3/1.8V
7	USB D+	I/O		USB 2.0 D+ signal	0.3---3V
8	W_DISABLE1#	I	PU	WWAN Disable, active low.	CMOS 3.3V
9	USB D-	I/O		USB 2.0 D- signal	0.3---3V
10	LED1#	O	OD	System status LED, drain output.	CMOS 3.3V
11	GND			GND	Power Supply
12	Notch			Notch	
13	Notch			Notch	
14	Notch			Notch	
15	Notch			Notch	
16	Notch			Notch	
17	Notch			Notch	
18	Notch			Notch	
19	Notch			Notch	
20	I2S_CLK	O	PD	I2S serial clock	CMOS 1.8V
21	CONFIG_0	O	NC	Not connected, L830 M.2 module is configured as the WWAN-SSIC 0 interface type.	
22	I2S_RX	I	PD	I2S serial data input	CMOS 1.8V

Pin	Pin Name	I/O	Reset Value	Pin Description	Type
23	WOWWAN#	O	PU	Wake up host signal	CMOS 1.8V
24	I2S_TX	O	PD	I2S serial data output	CMOS 1.8V
25	DPR	I	PU	Body SAR detection	CMOS 1.8V
26	W_DISABLE2#	I	PU	GPS Disable signal, active low. (Not supported yet)	CMOS 1.8V
27	GND			GND	Power Supply
28	I2S_WA	O	PD	I2S clock for left and right channels	CMOS 1.8V
29	NC			NC	
30	UIM_RESET	O	PP	USIM reset signal	1.8V/3V
31	NC			NC	
32	UIM_CLK	O	PP	USIM clock signal	1.8V/3V
33	GND			GND	Power Supply
34	UIM_DATA	I/O	PU	USIM data signal, internal 4.7K $\Omega$ pull-up.	1.8V/3V
35	NC			NC	
36	UIM_PWR	O		USIM power supply	1.8V/3V
37	NC			NC	
38	NC			NC	
39	GND			GND	Power Supply
40	GNSS_SCL	O	PU	I2C serial clock signal, internal 4.7K $\Omega$ pull-up	CMOS 1.8V
41	NC			NC	
42	GNSS_SDA	I/O	PU	I2C serial data signal, internal 4.7K $\Omega$ pull-up	CMOS 1.8V
43	NC			NC	
44	GNSS_IRQ	I	PU	Reserved	CMOS 1.8V
45	GND			GND	Power Supply
46	SYSCCLK	O	L	26MHz clock output	1.8V
47	NC			NC	

Pin	Pin Name	I/O	Reset Value	Pin Description	Type
48	TX_BLANKING	O	L	TDMA Timer output, external GPS control signal.(not supported)	CMOS 1.8V
49	NC			NC	
50	NC			NC	
51	GND			GND	Power Supply
52	NC			NC	
53	NC			NC	
54	NC			NC	
55	NC			NC	
56	NC			NC	
57	GND			GND	Power Supply
58	NC			NC	
59	ANTCTL0	O	L	Tunable antenna control signal, bit0 (not supported yet).	CMOS 1.8V
60	COEX3	O		Reserved	
61	ANTCTL1	O	L	Tunable antenna control signal, MIPI RFFE SDATA, bit1 (not supported yet).	CMOS 1.8V
62	COEX2	O		Reserved	
63	ANTCTL2	O	L	Tunable antenna control signal, MIPI RFFE SCLK, bit2 (not supported yet).	CMOS 1.8V
64	COEX1	O		Reserved	
65	ANTCTL3	O		Tunable antenna control signal, MIPI RFFE VIO, bit3 (not supported yet).	CMOS 1.8V
66	SIM_DETECT	I		SIM card detect, external 390KΩ pull-up.	CMOS 1.8V
67	RESET#	I		External reset input signal, internal 100KΩ pull-up.	CMOS 1.8V
68	NC			NC	
69	CONFIG_1	O	L	Connected to internal GND, L830	

Reproduction forbidden without Fibocom Wireless Inc. written authorization - All Rights Reserved.



Pin	Pin Name	I/O	Reset Value	Pin Description	Type
				M.2 module is configured as the WWAN-SSIC 0 interface type.	
70	+3.3V	PI		Module main power input.	Power Supply
71	GND			GND	Power Supply
72	+3.3V	PI		Module main power input.	Power Supply
73	GND			GND	Power Supply
74	+3.3V	PI		Module main power input.	Power Supply
75	CONFIG_2	O	L	Connected to internal GND, L830 M.2 module is configured as the WWAN-SSIC 0 interface type.	

Reset Value: The initial status after module reset, not the status when working

H: High Voltage Level

L: Low Voltage Level

PD: Pull-Down

PU: Pull-Up

T: Tristate

OD: Open Drain

PP: Push-Pull

PI: Power Input

PO: Power Output



**Note:**

The unused pins can be left floating.

## 3.2 Power Supply

The power interface of L830 module as shown in the following table:

Pin	Pin Name	I/O	Pin Description	DC Parameter (V)		
				Minimum Value	Typical Value	Maximum Value
2,4,70,72,74	+3.3V	PI	Power supply input	3.135	3.3	4.4
36	UIM_PWR	PO	USIM power supply		1.8V/3V	

Reproduction forbidden without Fibocom Wireless Inc. written authorization - All Rights Reserved.

### 3.2.1 Power Supply

The L830 module should be powered through the +3.3V pins, and the power supply design is shown in Figure 3-2:

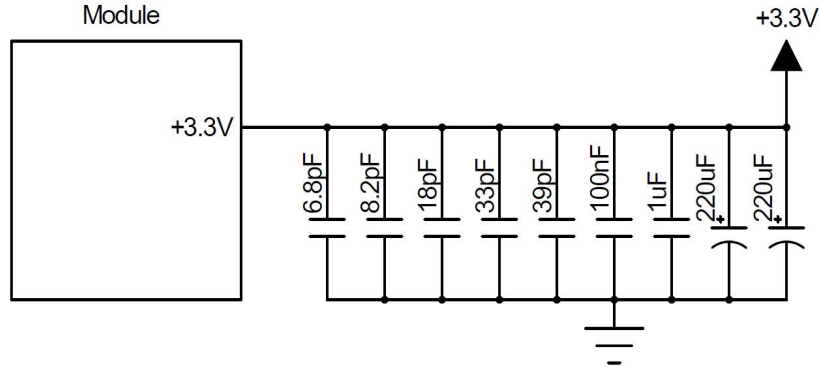

Figure 3-2 Power Supply Design

The filter capacitor design for power supply as shown in the following table:

Recommended capacitance	Application	Description
220uF x 2	Voltage-stabilizing capacitors	Reduce power fluctuations of the module in operation, requiring capacitors with low ESR. <ul style="list-style-type: none"> <li>● LDO or DC/DC power supply requires the capacitor of no less than 220uF</li> <li>● The capacitor for battery power supply can be reduced to 100uF</li> </ul>
1uF, 100nF	Digital signal noise	Filter out the interference generated from the clock and digital signals
39pF, 33pF	700,800,900 MHz frequency band	Filter out low frequency band RF interference
18pF, 8.2pF, 6.8pF	1800,2100,2600MHz frequency band	Filter out medium/high frequency band RF interference

The stable power supply can ensure the normal operation of L830 module; and the ripple of the power supply should be less than 300mV in design. When the module operates with the maximum emission power, the maximum operating current can reach 1A, so the power source should be not lower than 3.135V, or the module may shut down or reboot. The power supply limits are shown in Figure 3-3:

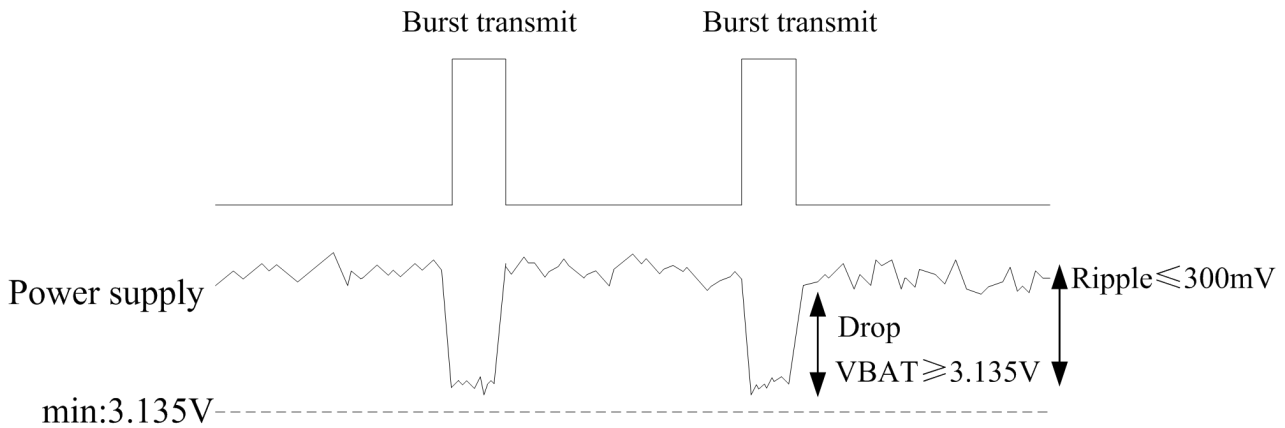

Figure 3-3 Power Supply Limit

### 3.2.2 Logic level

The L830 module 1.8V logic level definition as shown in the following table:

Parameters	Minimum	Typical	Maximum	Unit
1.8V logic level	1.71	1.8	1.89	V
V <sub>IH</sub>	1.3	1.8	1.89	V
V <sub>IL</sub>	-0.3	0	0.3	V

The L830 module 3.3V logic level definition as shown in the following table:

Parameters	Minimum	Typical	Maximum	Unit
3.3V logic level	3.135	3.3	3.465	V
V <sub>IH</sub>	2.3	3.3	3.465	V
V <sub>IL</sub>	-0.3	0	0.3	V

### 3.2.3 Power Consumption

In the condition of 3.3V power supply, the L830 power consumption as shown in the following table:

Parameter	Mode	Condition	Average Current(mA)
I <sub>off</sub>	Power off	Power supply, module power off	0.29
I <sub>Sleep</sub>	WCDMA	DRX=6	3.0
		DRX=8	1.8
		DRX=9	1.5

Parameter	Mode	Condition	Average Current(mA)
	LTE FDD	Paging cycle #64 frames (0.64 sec DRX cycle)	3.6
	Radio Off	AT+CFUN=4,Flight mode	1.0
I <sub>WCDMA-RMS</sub>	WCDMA	WCDMA Data transfer Band I @+23.5dBm	687
		WCDMA Data transfer Band VIII @+23.5dBm	597
I <sub>LTE-RMS</sub>	LTE FDD	LTE FDD Data transfer Band 1 @+23dBm	713
		LTE FDD Data transfer Band 3 @+23dBm	733
		LTE FDD Data transfer Band 7 @+23dBm	735
		LTE FDD Data transfer Band 8 @+23dBm	675
		LTE FDD Data transfer Band 20 @+23dBm	685
		LTE FDD Data transfer Band 28 @+23dBm	833



**Note:**

The data above is an average value obtained by testing some samples.

### 3.3 Control Signal

The L830 module provides two control signals for power on/off and reset operations, the pin defined as shown in the following table:

Pin	Pin Name	I/O	Reset Value	Functions	Type
6	FULL_CARD_POWER_OFF#	I		Power on/off signal High: Power on Low or floating: Power off	3.3V/1.8V
67	RESET#	I		Reset signal, internal 100KΩ pull-up, active low.	1.8V

#### 3.3.1 Module Start-Up

##### 3.3.1.1 Start-up Circuit

The FULL\_CARD\_POWER\_OFF# pin needs an external 3.3V or 1.8V pull up for booting up. The VDD(3.3V/1.8V) should be provided from the external circuit. Two methods for module starting up:

- AP (Application Processor) controls the module start-up, and the circuit design is shown in Figure 3-4:
- Automatically start-up when powered on, and the circuit design is shown in Figure 3-5:

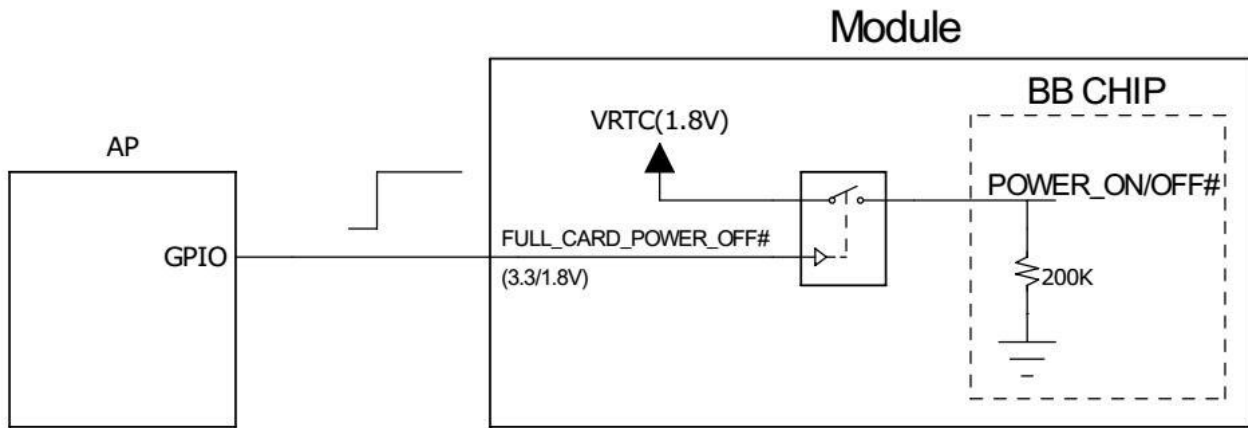

Figure 3-4 Circuit for Module Start-up Controlled by AP

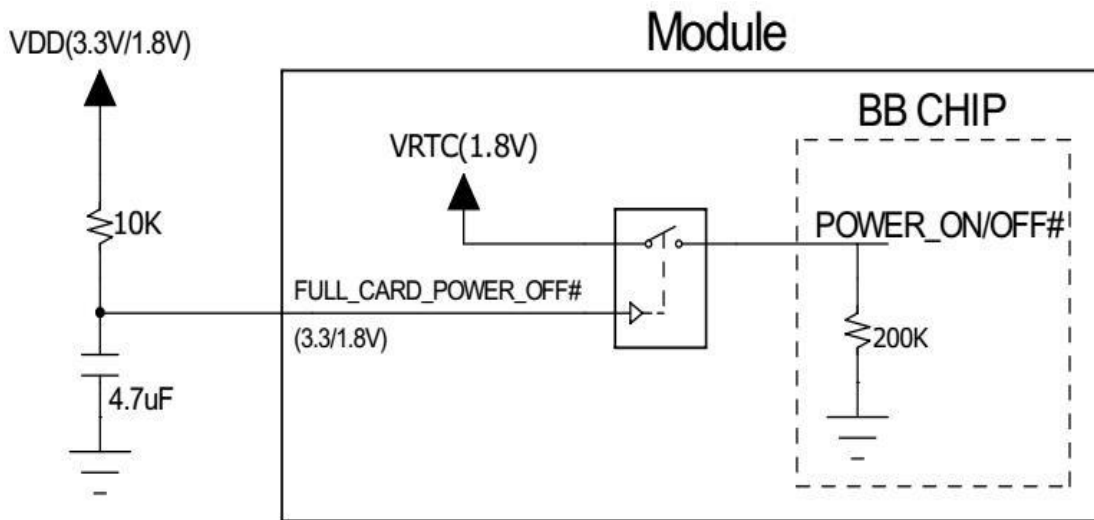

Figure 3-5 Circuit for Automatic Start-up

### 3.3.1.2 Start-up Timing Sequence

After powering on, module will start-up by pulling up FULL\_CARD\_POWER\_OFF# signal for more than 20ms (100ms is recommended). The internal PMU of the module will output the voltage and start the start-up process. After about 10s time, the module completes the initialization process. The start-up timing is shown in Figure 3-6:

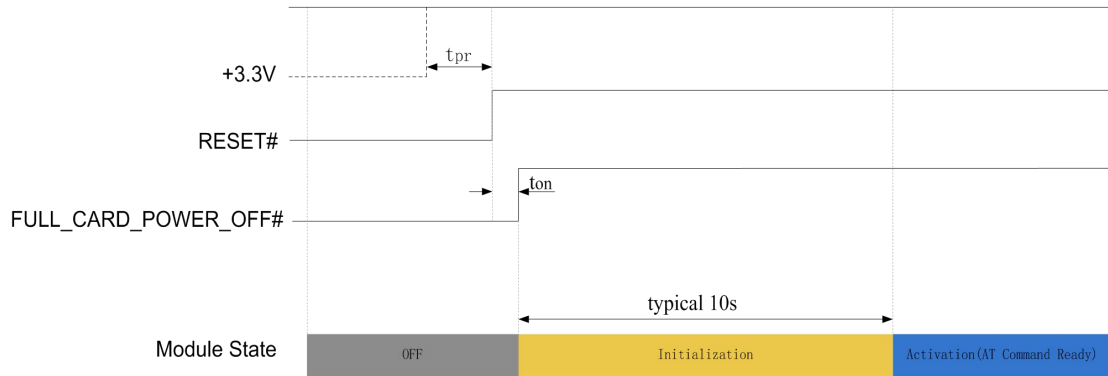

Figure 3-6 Timing Control for Start-up

Index	Minimum	Typical	Notes
$t_{pr}$			The time for +3.3 V stable output. If + 3.3 V keeps constant supply, the delay time can be ignored.
$t_{on}$	20ms	100ms	The time difference between the RESET # signal and the FULL_CARD_POWER_OFF # signal.

### 3.3.2 Module Shutdown

The module can be shutdown by the following controls:

Shutdown Control	Action	Condition
Software	Sending AT+CFUN=0 command	Normal shutdown.
Hardware	Pull down FULL_CARD_POWER_OFF# pin	Only used when a hardware exception occurs and the software control cannot be used.

Module can be shut down by sending AT+CFUN=0 command. When module receives the software shutdown command, it will start the finalization process (the reverse process of initialization), then it will shut down after  $t_{sd}$  time (AP received "OK" from "AT+CFUN=0" command, if AP can't received "OK" the time is 5s maxim). In the finalization process, the module will save the network, SIM card and some other parameters from memory, then clear the memory and PMU will be powered off. The software control timing is shown in Figure 3-7:

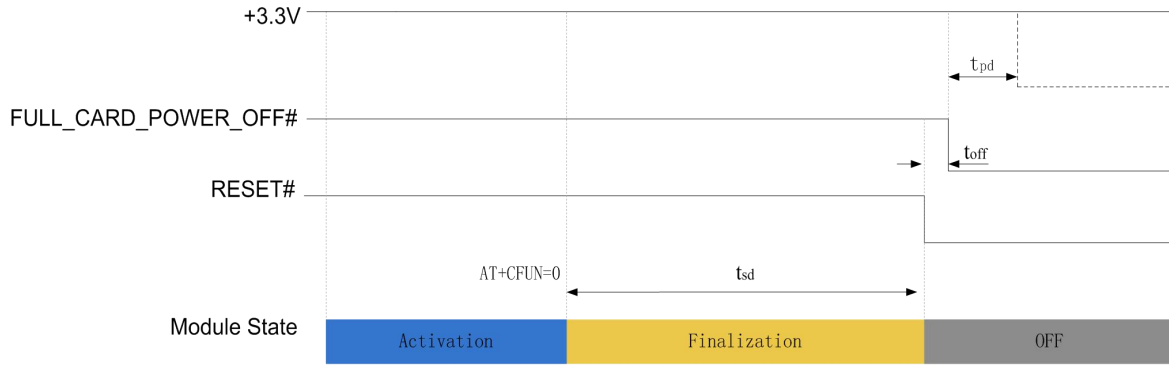

Figure 3-7 Shutdown Timing Control

Index	Minimum	Typical	Notes
$t_{pd}$	10ms	100ms	The time for +3.3 V delay time of shutdown. If + 3.3 V keeps constant supply, the delay time can be ignored.
$t_{off}$	10ms	100ms	The time difference between the RESET # signal and the FULL_CARD_POWER_OFF # signal.

### 3.3.3 Module Reset

The L830 module can reset to its initial status by pulling down the RESET# signal for more than 20ms (100ms is recommended), and the module will restart after the RESET# signal is released. When the customer executes RESET# function, the PMU remains its power inside the module. The recommended circuit design is shown in the Figure 3-8:

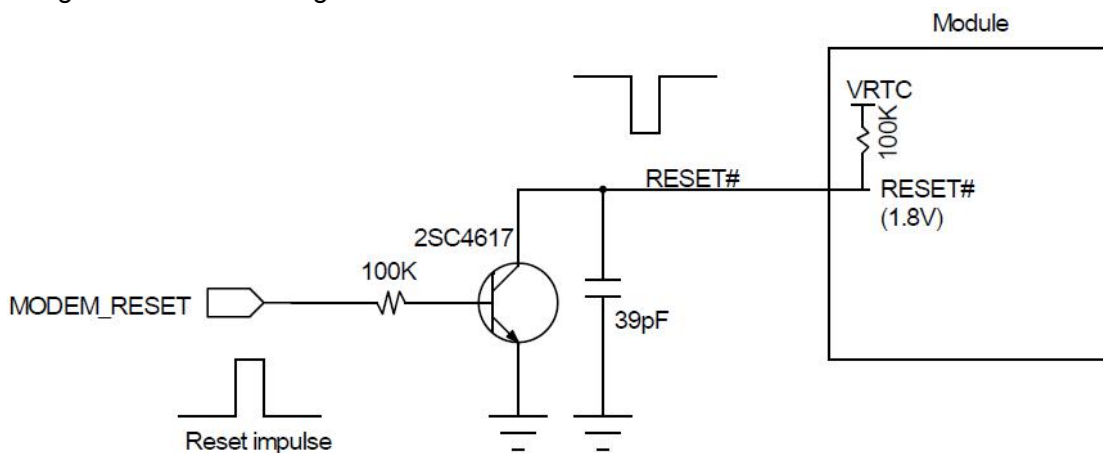

Figure 3-8 Recommended Design for Reset Circuit

The reset control timing is shown in Figure 3-9:

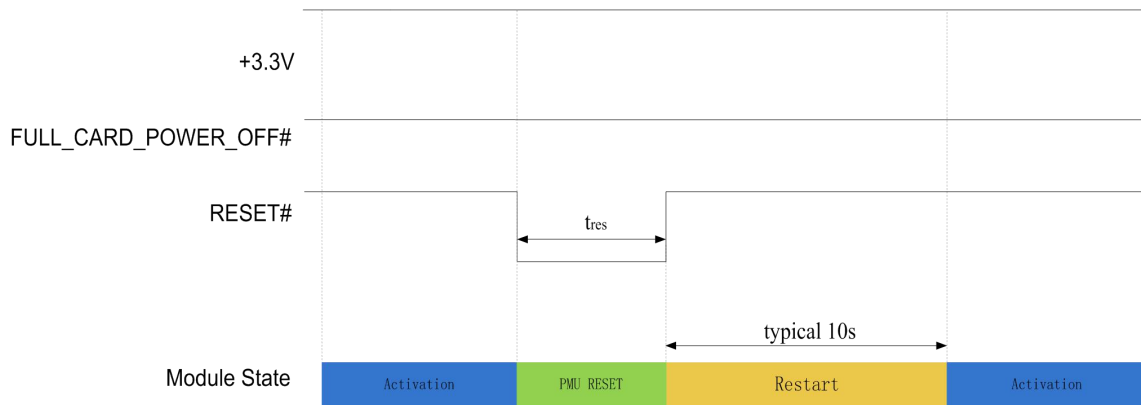

Figure 3-9 Reset Timing Control

Index	Minimum	Typical	Notes
$t_{res}$	20ms	100ms	RESET# signal to pull down time

## 3.4 USB Interface

The L830 module supports USB 2.0 which is compatible with USB High-Speed (480 Mbit/s) and USB Full-Speed (12 Mbit/s). For the USB timing and electrical specification of L830 module, please refer to “Universal Serial Bus Specification 2.0” .

### 3.4.1 USB Interface Definition

Pin#	Pin Name	I/O	Reset Value	Description	Type
7	USB_D+	I/O	T	USB Data Plus	0.3---3V, USB2.0
9	USB_D-	I/O	T	USB Data Minus	0.3---3V, USB2.0

### 3.4.2 USB Interface Application

The reference circuit is shown in Figure 3-10:



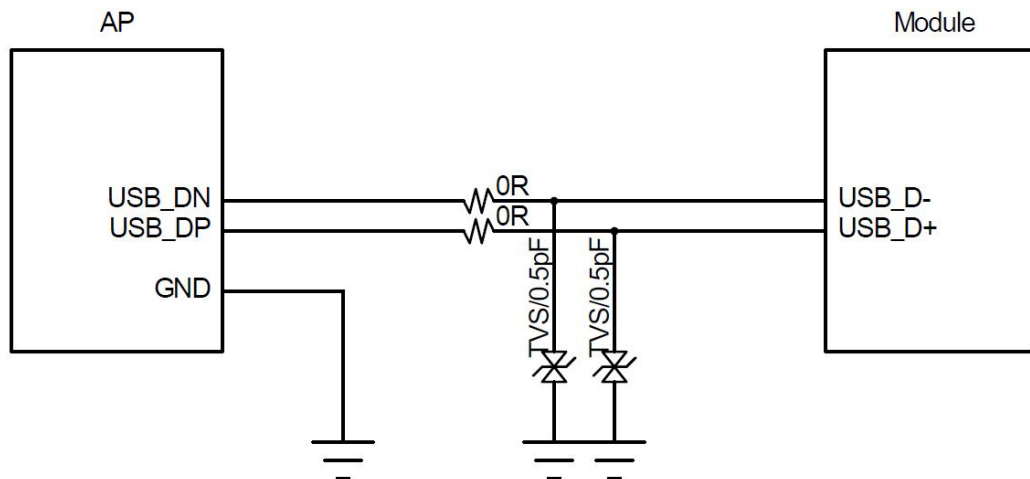

Figure 3-10 Reference Circuit for USB 2.0 Interface

Since the module supports USB 2.0 High-Speed, it is required to use TVS diodes with equivalent capacitance of 1pF or smaller ones on the USB\_D-/D+ differential signal lines, it is recommended to use 0.5pF TVS diodes.

USB\_D- and USB\_D+ are high speed differential signal lines with the maximum transfer rate of 480 Mbit/s, so the following rules shall be followed carefully in the case of PCB layout:

- USB\_D- and USB\_D+ signal lines should have the differential impedance of 90 ohms.
- USB\_D- and USB\_D+ signal lines should be parallel and have the equal length, the right angle routing should be avoided.
- USB\_D- and USB\_D+ signal lines should be routed on the layer that is adjacent to the ground layer, and wrapped with GND vertically and horizontally.

## 3.5 USIM Interface

The L830 module supports USIM card interface including 1.8V and 3V SIM cards.

### 3.5.1 USIM Pins

The USIM pins description as shown in the following table:

Pin	Pin Name	I/O	Reset Value	Description	Type
36	UIM_PWR	PO		USIM power supply	1.8V/3V
30	UIM_RESET	O	L	USIM reset	1.8V/3V
32	UIM_CLK	O	L	USIM clock	1.8V/3V
34	UIM_DATA	I/O	L	USIM data, internal 4.7K pull-up	1.8V/3V

Pin	Pin Name	I/O	Reset Value	Description	Type
66	SIM_DETECT	I		USIM card detect, internal 390K pull-up. Active high, and high level indicates SIM card is inserted; and low level indicates SIM card is detached.	1.8V

### 3.5.2 USIM Interface Circuit

#### 3.5.2.1 N.C. SIM Card Slot

The reference circuit design for N.C. (Normally Closed) SIM card slot is shown in Figure 3-11:

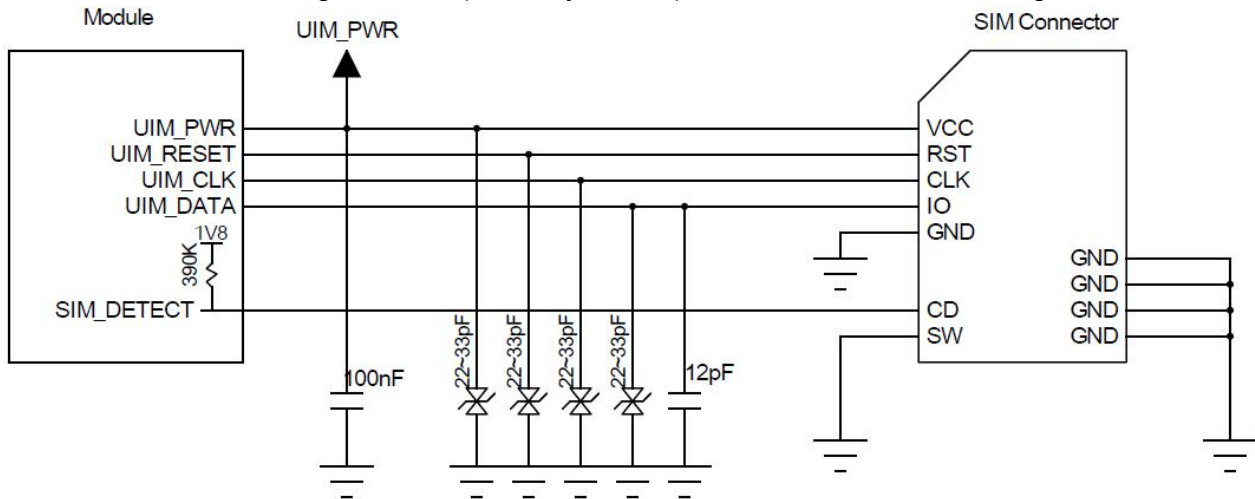

Figure 3-11 Reference Circuit for N.C. SIM Card Slot

The principles of the N.C. SIM card slot are described as follows:

- When the SIM card is detached, it connects the short circuit between CD and SW pins, and drives the SIM\_DETECT pin low.
- When the SIM card is inserted, it connects an open circuit between CD and SW pins, and drives the SIM\_DETECT pin high.

#### 3.5.2.2 N.O. SIM Card Slot

The reference circuit design for N.O. (Normally Open) SIM card slot is shown in Figure 3-12:

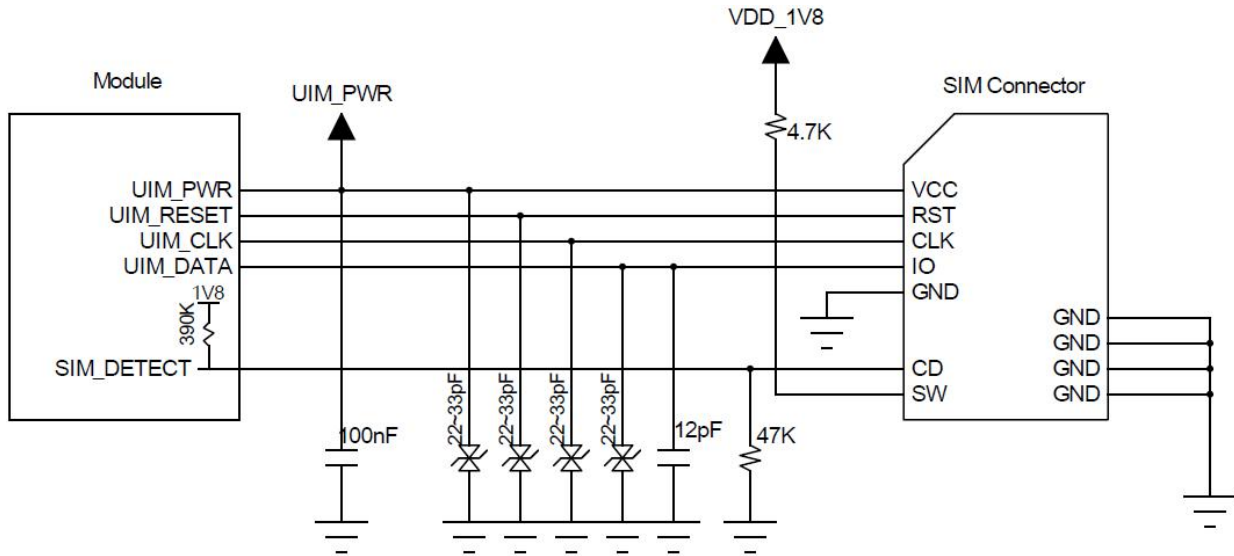

Figure 3-12 Reference Circuit for N.O. SIM Card Slot

The principles of the N.O. SIM card slot are described as follows:

- When the SIM card is detached, it connects an open circuit between CD and SW pins, and drives the SIM\_DETECT pin low.
- When the SIM card is inserted, it connects the short circuit between CD and SW pins, and drives the SIM\_DETECT pin high.

### 3.5.3 USIM Hot-Plugging

The L830 module supports the SIM card hot-plugging function, which determines whether the SIM card is inserted or detached by detecting the SIM\_DETECT pin state of the SIM card slot.

The SIM card hot-plugging function can be configured by “AT+MSMPD” command, and the description for AT command as shown in the following table:

AT Command	Hot-plugging Detection	Function Description
AT+MSMPD=1	Enable	Default value, the SIM card hot-plugging detection function is enabled. The module can detect whether the SIM card is inserted or not through the SIM_DETECT pin state.
AT+MSMPD=0	Disable	The SIM card hot-plugging detect function is disabled. The module reads the SIM card when starting up, and the SIM_DETECT status will not be detected.

After the SIM card hot-plugging detection function is enabled, the module detects that the SIM card is inserted when the SIM\_DETECT pin is high, then executes the initialization program and finish the network registration after reading the SIM card information. When the SIM\_DETECT pin is low, the module determines that the SIM card is detached and does not read the SIM card.



**Note:**

By default, SIM\_DETECT is active-high, which can be switched to active-low by the AT command. Please refer to the AT Commands Manual for the AT command.

The system doesn't need SIM hot-plug function, please left SIM\_DETECT floating.

### 3.5.4 USIM Design

The SIM card circuit design shall meet the EMC standards and ESD requirements with the improved capability to resist interference, to ensure that the SIM card can work stably. The following guidelines should be noted in case of design:

- The SIM card slot placement should near the module as close as possible, and away from the RF antenna, DC/DC power supply, clock signal lines, and other strong interference sources.
- The SIM card slot with a metal shielding housing can improve the anti-interference ability.
- The trace length between the SIM card slot and the module should not exceed 100mm, or it could reduce the signal quality.
- The UIM\_CLK and UIM\_DATA signal lines should be isolated by GND to avoid crosstalk interference. If it is difficult for the layout, the whole SIM signal lines should be wrapped with GND as a group at least.
- The filter capacitors and ESD devices for SIM card signals should be placed near to the SIM card slot, and the ESD devices with 22~33pF capacitance should be used.

## 3.6 Status Indicator

The L830 module provides three signals to indicate the operating status of the module, and the status indicator pins as shown in the following table:

Pin	Pin Name	I/O	Reset Value	Pin Description	Type
10	LED1#	O	PD	System status LED, drain output.	CMOS 3.3V
23	WOWWAN#	O	PU	Module wakes up Host (AP).	CMOS 1.8V

Reproduction forbidden without Fibocom Wireless Inc. written authorization - All Rights Reserved.

### 3.6.1 LED#1 Signal

The LED#1 signal is used to indicate the operating status of the module, and the detailed description as shown in the following table:

Module Status	LED1# Signal
RF function ON	Low level (LED On)
RF function OFF	High level (LED Off)

The LED driving circuit is shown in figure 3-13:

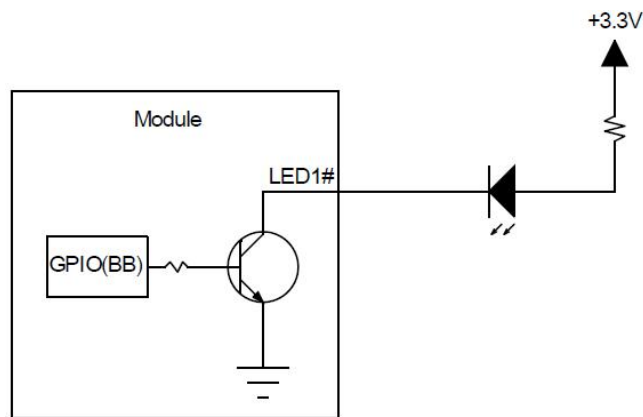

Figure 3-13 LED Driving Circuit



**Note:**

The resistance of LED current-limiting resistor is selected according to the driving voltage and the driving current.

### 3.6.2 WOWWAN#

The WOWWAN# signal is used to wake the Host (AP) when there comes the data request. The definition of WOWWAN# signal is as follows:

Operating Mode	WOWWAN# Signal
Ringling /SMS or data requests	Pull low 1s then pull high (pulse signal).
Idle/Sleep	High level

The WOWWAN# timing is shown in Figure 3-14:

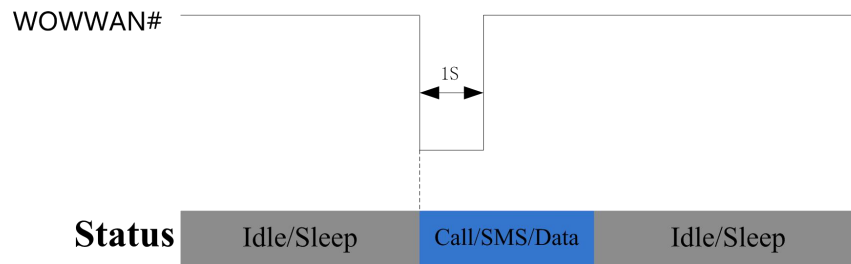

Figure 3-14 WOWWAN# Timing

## 3.7 Interrupt Control

The L830 module provides four interrupt signals, and the pin definition is as follows:

Pin	Pin Name	I/O	Reset Value	Pin Description	Type
8	W_DISABLE1#	I	PU	Enable/Disable RF network	CMOS 3.3V
25	DPR	I	PU	Body SAR detection	CMOS 1.8V

### 3.7.1 W\_DISABLE1#

The module provides a hardware pin to enable/disable WWAN RF function, and the function can also be controlled by the AT command. The module enters the Flight mode after the RF function is disabled. The definition of W\_DISABLE1# signal is as follows:

W_DISABLE1# signal	Function
High/Floating	WWAN function is enabled, the module exits the Flight mode.
Low	WWAN function is disabled, the module enters Flight mode.

### 3.7.2 Body SAR

The L830 module supports Body SAR function by detecting the DPR pin. The voltage level of DPR is high by default, and when the SAR sensor detects the closing human body, the DPR signal will be pulled down. As the result, the module then lowers down its emission power to its default threshold value, thus reducing the RF radiation on the human body. The threshold of emission power can be set by the AT Commands. The definition of DPR signal as shown in the following table:

DPR signal	Function
High/Floating	The module keeps the default emission power
Low	Lower the maximum emission power to the threshold value of the module.

## 3.8 Digital Audio

The L830 module supports I2S digital audio interface and it supports the ordinary I2S mode and PCM mode. The signal level of the I2S interface is 1.8V. Please refer to “FIBOCOM Digital Voice” description for detailed application design. The definition of I2S signals is as follows:

Pin	Pin Name	I/O	Reset Value	Pin Description	Type
20	I2S_CLK	O	PD	I2S clock	CMOS 1.8V
22	I2S_RX	I	PD	I2S serial data receive	CMOS 1.8V
24	I2S_TX	O	PD	I2S serial data transmit	CMOS 1.8V
26	I2S_WA	O	PD	I2S left and right channel clock (LRCK)	CMOS 1.8V

### 3.8.1 I2S Mode

The L830 module is connected to the Audio Codec via I2S interface, and the codec encodes the audio data to implement the voice call function. For the scenario, the module works as the I2S master, and the codec works as the I2S slave. I2S signal connection is shown in Figure 3-18:

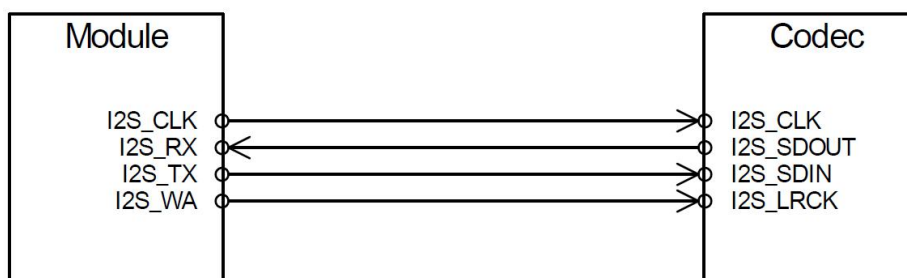

Figure 3-18 I2S Signal Connection

Description:

- I2S interface can be configured as master or slave mode.
- It supports multiple audio sampling rates (44.1KHz,32KHz,24KHz,16KHz,8KHz).
- It supports 16bit and 32bit mode.

### 3.8.2 PCM Mode

In the case of the Bluetooth (BT) call, the PCM mode is used to transmit digital voice data if the BT chip does not support I2S. For the scenario, the module works as the PCM master, and BT works as the PCM slave mode. The signal connection under the PCM mode is shown in Figure 3-19:

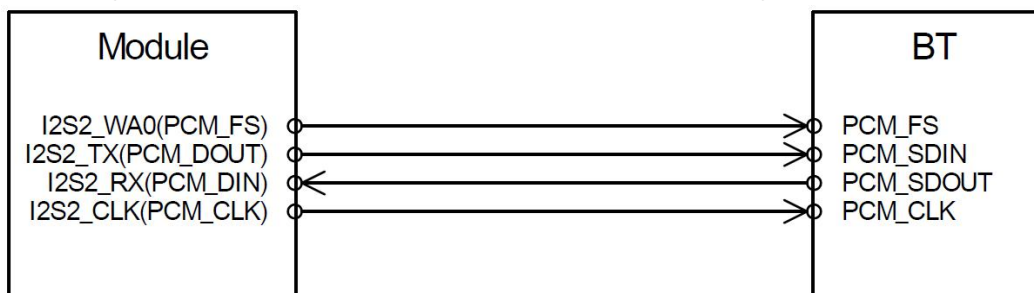

Figure 3-19 Signal Connection for PCM Mode

Description:

- The PCM mode interface can be configured as master or slave mode.
- It supports various audio sampling rates (44.1KHz,32KHz,24KHz,16KHz,8KHz).
- It supports short frame sync for 16 and 32 bit mode.
- It supports burst and continuous transmission modes.
- It supports clock length trigger for frame sync signal and rising/falling edge trigger for data transmission.



**Note:**

The PCM mode timing is relative complicated to adjust, and the audio quality will be reduced if it is not fine tuned. In contrast to PCM mode, I2S mode is easier to adjust, hence it is recommended to use I2S mode.

## 3.9 I2C Interface Description

The L830 module supports one I2C interface, which is configured as I2C master by default. The I2C master is used for driving external I2C slave devices, such as the Audio Codec.



Pin	Pin Name	I/O	Reset Value	Pin Description	Type
40	GNSS_SCL	O	PU	I2C serial data, internal 4.7KΩ pull up.	CMOS 1.8V
42	GNSS_SDA	I/O	PU	I2C serial clock, internal 4.7KΩ pull up.	CMOS 1.8V

The module is connected to the external I2C slave devices (e.g. Audio Codec), which is as follows:

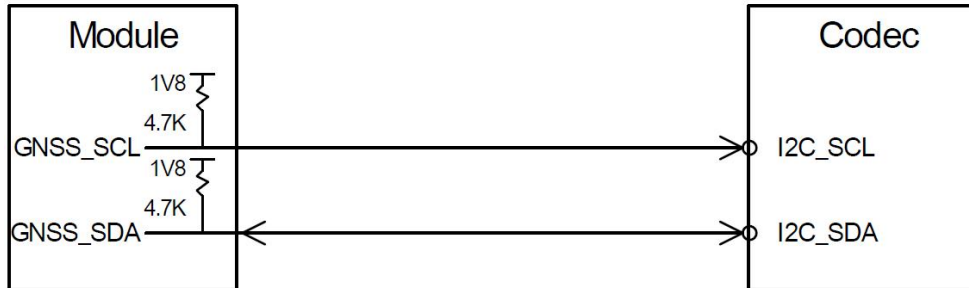

Figure 3-20 I2C Signal Connection



**Note:**

The I2C interface pins can be left floating if not used.

### 3.10 Clock Interface

The L830 module supports a clock interface, it can output 26MHz clock.

Pin	Pin Name	I/O	Reset Value	Pin Description	Type
46	SYSCCLK	O		26MHz clock output, can be used for external GPS or Audio Codec.	1.8V

### 3.11 Configuration Interface

The L830 module provides four config pins for the configuration as the WWAN-SSIC-0 type M.2 module:

Pin	Pin Name	I/O	Reset Value	Pin Description	Type
1	CONFIG_3	O	L	Internally connected to GND	
21	CONFIG_0	O		NC	
69	CONFIG_1	O	L	Internally connected to GND	
75	CONFIG_2	O	L	Internally connected to GND	

The M.2 module configuration as the following table:

Config_0 (pin21)	Config_1 (pin69)	Config_2 (pin75)	Config_3 (pin1)	Module Type and Main Host Interface	Port Configuration
NC	GND	GND	GND	WWAN-SSIC	0

Please refer to “PCI\_Express\_M.2\_Specification\_Rev1.1” for more details.

### 3.12 Other Interfaces

The module does not support ANT Tunable interface yet.

## 4 Radio Frequency

### 4.1 RF Interface

#### 4.1.1 RF Interface Functionality

The L830 module supports two RF connectors used for external antenna connection. As the Figure 4-1 shows, “M” is for Main antenna, used to receive and transmit RF signals; “D/G” is for Diversity antenna, used to receive the diversity RF signals.

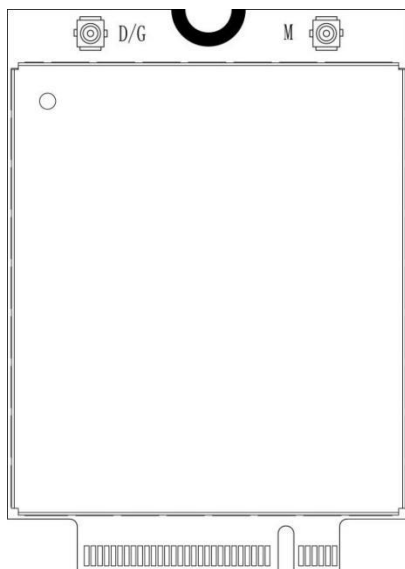

Figure 4-1 RF connectors

#### 4.1.2 RF Connector Characteristic

Rated Condition		Environment Condition
Frequency Range	DC to 6GHz	Temperature Range
Characteristic Impedance	50Ω	-40°C to +85°C

### 4.1.3 RF Connector Dimension

The L830 module adopts standard M.2 module RF connectors, the model name is 818004607 from ETC company, and the connector size is 2\*2\*0.6mm. The connector dimension is shown as following picture:

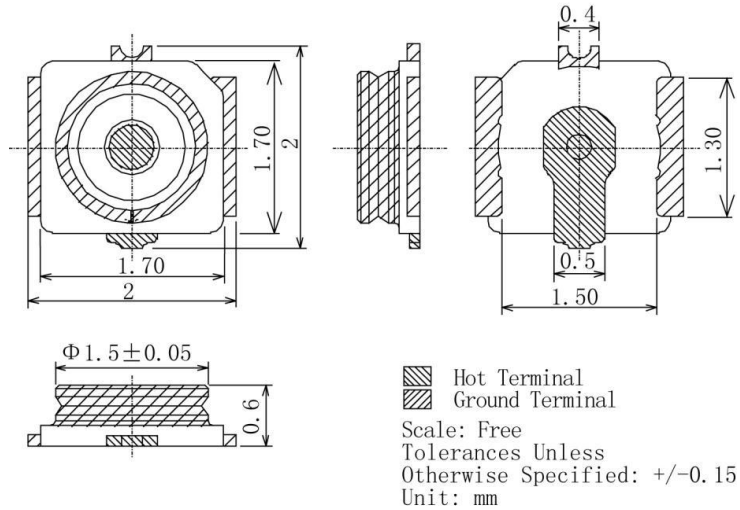

Figure 4-2 RF connector dimensions

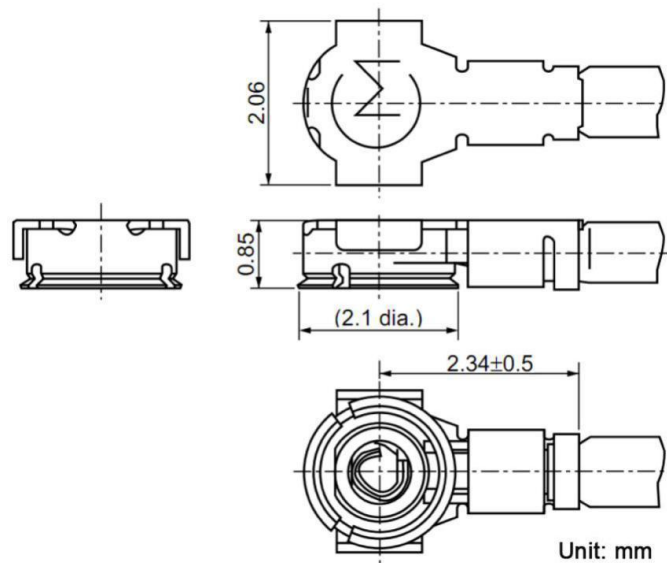

Figure 4-3 0.81mm coaxial antenna dimensions

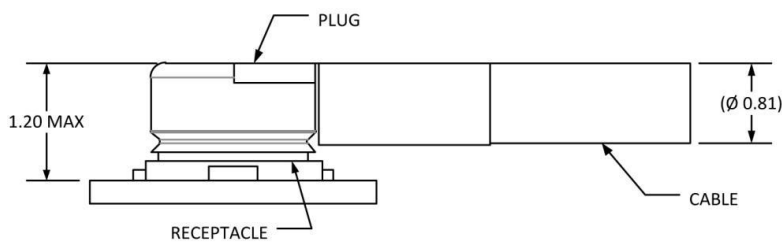

Figure 4-4 Schematic diagram of 0.81mm coaxial antenna connected to the RF connector

## 4.2 Operating Band

The L830 module operating bands of the antennas are as follows:

Operating Band	Description	Mode	Tx (MHz)	Rx (MHz)
Band 1	IMT 2100MHz	LTE FDD/WCDMA	1920 - 1980	2110 - 2170
Band 3	DCS 1800MHz	LTE FDD	1710 - 1785	1805 - 1880
Band 7	IMT-E 2600Mhz	LTE FDD	2500 - 2570	2620 - 2690
Band 8	E-GSM 900MHz	LTE FDD/WCDMA	880 - 915	925 - 960
Band 20	EUDD 800MHz	LTE FDD	832 - 862	791 - 821
Band 28	APT700	LTE FDD	703-748	758-803
Band 32	L-Band1500	LTE FDD	N/A	1452-1496

## 4.3 Transmitting Power

The transmitting power for each band of the L830 module as shown in the following table:

Mode	Band	3GPP Requirement	Tx Power(dBm)	Note
WCDMA	Band I	24+1.7/-3.7	23.5±1	
	Band VIII	24+1.7/-3.7	23.5±1	
LTE FDD	Band 1	23±2.7	23±1	10MHz Bandwidth, 1 RB
	Band 3	23±2.7	23±1	10MHz Bandwidth, 1 RB
	Band 7	23±2.7	23±1	10MHz Bandwidth, 1 RB
	Band 8	23±2.7	23±1	10MHz Bandwidth, 1 RB
	Band 20	23±2.7	23±1	10MHz Bandwidth, 1 RB
	Band 28	23+2.7/-3.2	23±1	10MHz Bandwidth, 1 RB

## 4.4 Receiver Sensitivity

The receiver sensitivity for each band of the L830 module as shown in the following table:

Mode	Band	3GPP Requirement	Rx Sensitivity(dBm) Typical	Note
WCDMA	Band I	-106.7	-110	BER<0.1%

Mode	Band	3GPP Requirement	Rx Sensitivity(dBm)	Note
			Typical	
	Band VIII	-103.7	-110.5	BER<0.1%
LTE FDD	Band 1	-96.3	-101	10MHz Bandwidth
	Band 3	-93.3	-101	10MHz Bandwidth
	Band 7	-94.3	-101.5	10MHz Bandwidth
	Band 8	-93.3	-101	10MHz Bandwidth
	Band 20	-93.3	-101	10MHz Bandwidth
	Band 28	-94.8	-101	10MHz Bandwidth
	Band 32	-96.5	TBD	10MHz Bandwidth



**Note:**

The above values are measured for the dual antennas situation (Main + Diversity). For single main antenna (without Diversity), the sensitivity will drop around 3dBm for each band of LTE.

## 4.5 GNSS

L830-EB-11 module not support GNSS.

## 4.6 Antenna Design

The L830 module provides main and diversity antenna interfaces, and the antenna design requirements as shown in the following table:

L830 module Main antenna requirements	
Frequency range	The most proper antenna to adapt the frequencies should be used.
Bandwidth(WCDMA)	WCDMA band I(2100) : 250 MHz WCDMA band VIII(900) : 80 MHz
Bandwidth(LTE)	LTE band 1(2100): 250 MHz LTE Band 3(1800): 170 MHz LTE band 7(2600): 190 MHz LTE Band 8(900): 80 MHz LTE band 20(800): 71 MHz LTE band 28(850): 100 MHz LTE band 32(700): 11 MHz
Impedance	50 Ohm

L830 module Main antenna requirements	
Input power	> 25dBm average power WCDMA & LTE
Recommended standing-wave ratio (SWR)	$\leq 2:1$

## 5 Structure Specification

### 5.1 Product Appearance

The product appearance for L830 module is shown in Figure 5-1:

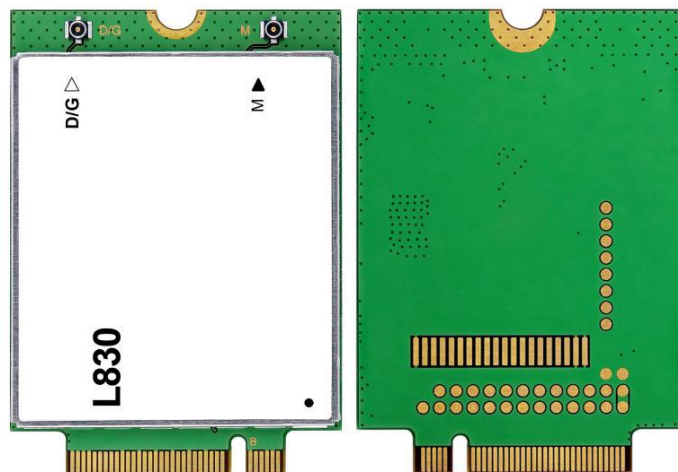

Figure 5-1 Module Appearance

### 5.2 Dimension of Structure

The structural dimension of the L830 module is shown in Figure 5-2:

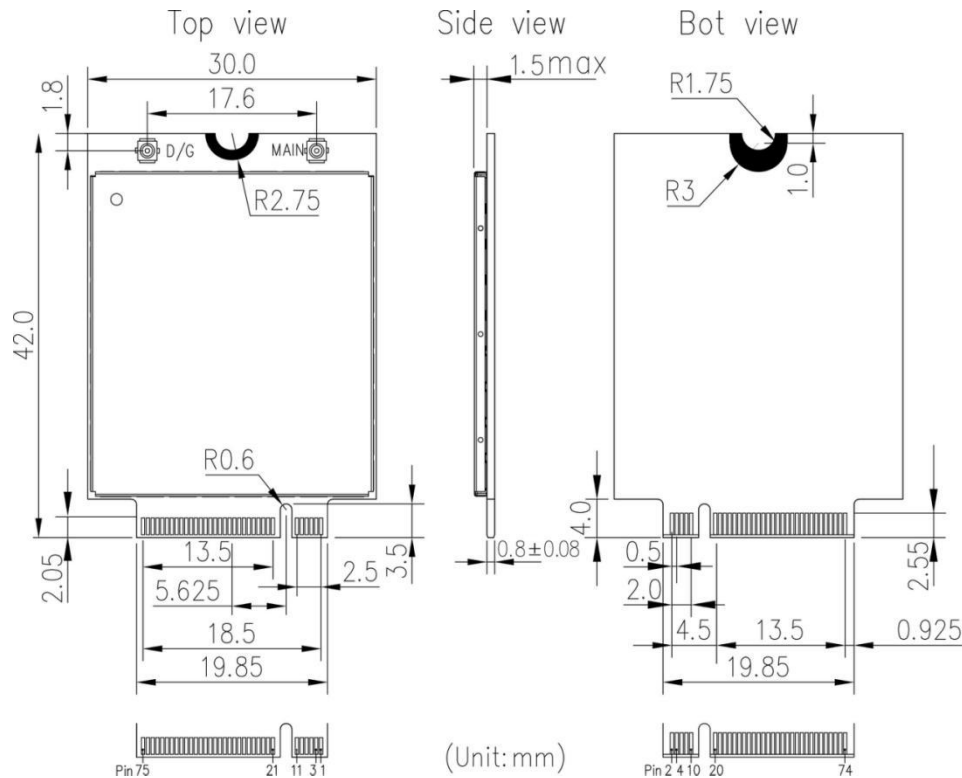

Figure 5-2 Dimension of Structure

### 5.3 M.2 Interface Model

The L830 M.2 module adopts 75-pin gold finger as external interface, where 67 pins are signal pins and 8 pins are notch pins as shown in Figure 3-1. For module dimension, please refer to chapter 5.2. Based on the M.2 interface definition, L830 module adopts Type 3042-S3-B interface (30x42mm, the component maximum height on t top layer is 1.5mm, PCB thickness is 0.8mm, and KEY ID is B).

**Module Nomenclature**  
**Sample type 3042-S3-B**

Type **XX** **XX** - **XX** - **X** - **X<sup>0</sup>**

Width (mm)	Length (mm)	Component Max Ht (mm)		
		Top Max <sup>(1)</sup>	Bottom Max <sup>(2)</sup>	
12	16	S1	1.2	0****
16	26	S2	1.35	0****
22	30	S3	1.5	0****
30	38	D1	1.2	1.35
	42	D2	1.35	1.35
	60	D3	1.5	1.35
	80	D4	1.5	0.7
	110	D5	1.5	1.5

Key ID	Pin	Interface
A	8-15	2x PCIe x1 / USB 2.0 / I2C / DP x4
B	12-19	PCIe x2/SATA/USB 2.0/USB 3.0/HSIC/SSIC/Audio/UIM/I2C
C	16-23	Reserved for Future Use
D	20-27	Reserved for Future Use
E	24-31	2x PCIe x1 / USB 2.0 / I2C / SDIO / UART / PCM
F	28-35	Future Memory Interface (FMI)
G	39-46	Generic (Not used for M.2)***
H	43-50	Reserved for Future Use
J	47-54	Reserved for Future Use
K	51-58	Reserved for Future Use
L	55-62	Reserved for Future Use
M	59-66	PCIe x4 / SATA

- ☒ Use ONLY when a double slot is being specified
- ☒☒ Label included in height dimension
- ☒☒☒ Key G is intended for custom use. Devices with this key will not be M.2-compliant. Use at your own risk!
- ☒☒☒☒ Insulating label allowed on connector-based designs

## 5.4 M.2 Connector

The L830 module connects to AP via M.2 connector, it is recommended to use M.2 connector from LOTES company with the model APCI0026-P001A as shown in Figure 5-3. The package of connector, please refer to the specification.

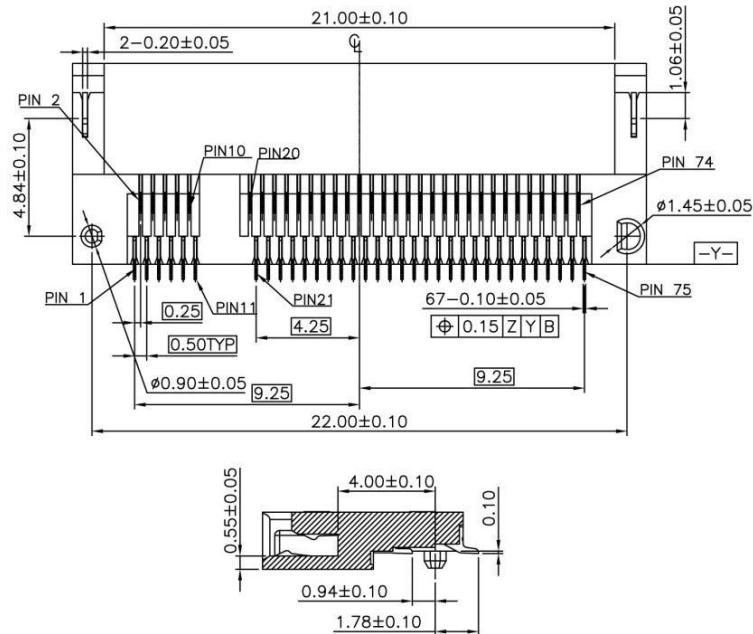

Figure 5-3 M.2 Dimension of Structure

## 5.5 Storage

### 5.5.1 Storage Life

Storage Conditions (recommended): Temperature is  $23 \pm 5$  °C, relative humidity is RH 35-70%.

Storage period (sealed vacuum packing): Under the recommended storage conditions, the storage life is 12 months.

## 5.6 Packing

The L830 module uses the tray sealed vacuum packing, combined with the outer packing method using the hard cartoon box, so that the storage, transportation and the usage of modules can be protected to the greatest extent.





**Note:**

The module is a precision electronic product, and may suffer permanent damage if no correct electrostatic protection measures are taken.

## 5.6.1 Tray Package

The L830 module uses tray package, 20 pcs are packed in each tray, with 5 trays in each box and 6 boxes in each case. Tray packaging process is shown in Figure 5-4:

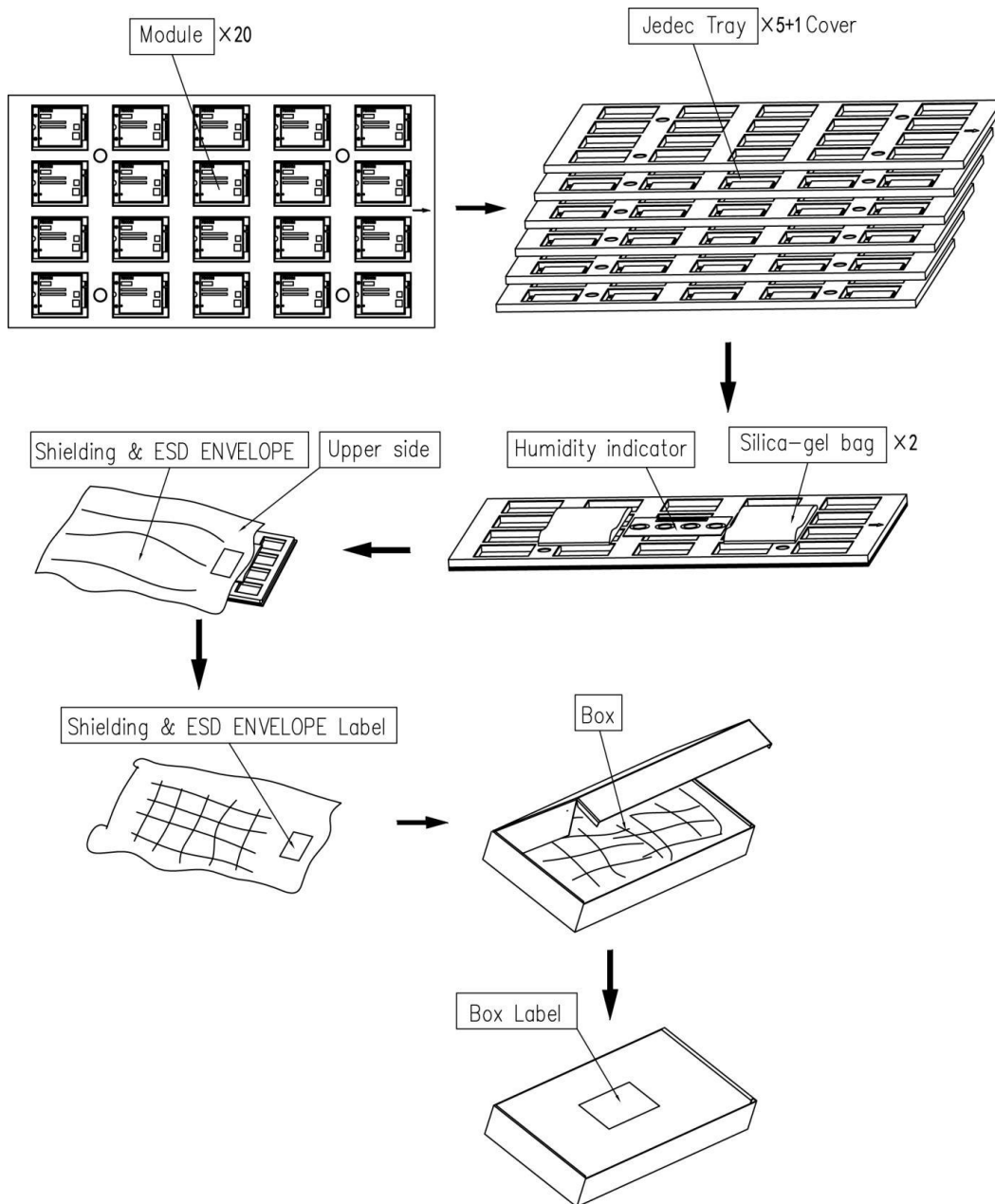
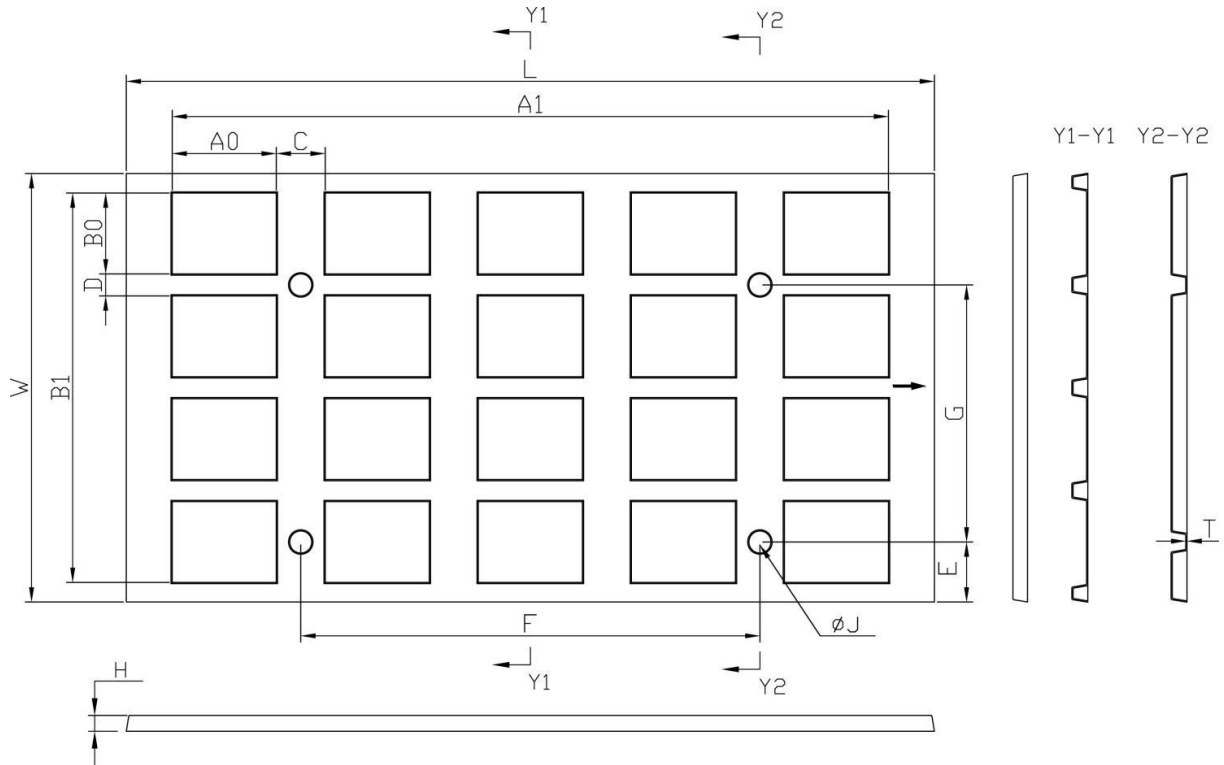

Figure 5-4 Tray Packaging Process

### 5.6.2 Tray size

The pallet size is 330\*175\*6.0mm, as shown in Figure 5-5:



<b>ITEM</b>	L	W	H	T	A0	B0
<b>DIM</b>	330.0±0.5	175.0±0.5	6.0±0.3	0.5±0.1	43±0.3	33.0±0.3
<b>ITEM</b>	A1	B1	C	D	E	F
<b>DIM</b>	294.0±0.3	159.0±0.3	20.0±0.5	9.0±0.5	24.5±0.5	187.5±0.2
<b>ITEM</b>	G	J				
<b>DIM</b>	105.0±0.2	9.0±0.2				

Figure 5-5 Tray Size (Unit: mm)