

WIRELESS WEATHER STATION

INSTRUCTION MANUAL

	Page
1. Introduction.....	2
2. Inventory of contents.....	2
Feature of the base station.....	2
Feature of wind sensor.....	3
Feature of rain sensor.....	3
3. Set up guide.....	3
3.1 Battery install.....	3
3.2 Mounting.....	4
4. LCD overview.....	5
4.1 LCD overview.....	5
4.2 Weather forecasting.....	6
4.3 Weather forecast tendency indicator.....	6
4.4 Storm warning indicator.....	6
5. Program modes.....	7
5.1 Quick display mode.....	7
5.2 Setting mode.....	7
5.3 History mode.....	8
5.4 Alarm mode.....	9
5.5 Min/Max mode.....	9
6. Problems and interference with operation.....	10
7. Specification.....	10

This Operation Manual is part of this product and should be kept in a safe place for future reference. It contains important notes on setup and operation.

1. Introduction

Thank you for purchasing this Professional Weather Center Designed for everyday use, the weather station will prove to be an asset of great value for your personal use in the home or office. Please read this instruction manual thoroughly to fully understand the correct operation of your weather station and benefit from its unique features.

2. Inventory of contents

- 1) Base station
- 2) WH1 sensor including thermo-hygro sensor, rain sensor, wind sensor
- 3) Instruction manual
- 4) 2 adjustable hoops (to fix the mast to your desired location)

The received data is continuously updated to bring you the latest weather information on the base station's LCD. The outdoor thermo-hygro sensors is the main data communication unit since both the wind and rain sensors are connected to the thermo-hygro sensor for operating power and rely on it to communicate to the base station. Weather data sent from the thermo-hygro sensor is transmitted through wireless link.

Additional equipment (not included)

1. 3 Fresh AA 1.5V LR6 Alkaline batteries.
2. 2 Fresh AA 1.5V LR6 Alkaline batteries.

Feature of the base station:

- Indoor and outdoor temperature display in degrees Fahrenheit or Celsius (user selectable)
- Indoor and outdoor relative humidity displays
- Barometric pressure reading in inHg or hPa, absolute or relative (user selectable)
- Detailed display of rainfall data in 1 hour, 24 hours, one week, one month and total since last reset. (user selectable in mm or inch)
- Wind speed in mph, km/h, m/s, knots or Beaufort (user selectable)
- Wind chill temperature display
- Dew point temperature display
- Weather forecast display by weather icons (sunny, cloudy, rainy)
- Weather forecast tendency arrow
- Storm warning alarm
- Display of extensive weather data, in all cases with programmable alarm functions for certain weather conditions as well as records of all minimum and maximum values along with time and date of their recordings
- Super bright green LED back light
- DCF Radio controlled time and date with manual setting option
- 12 or 24 hour time display
- Perpetual calendar
- Time zone setting
- Automatic daylight saving time function based on Germany DST system (for those users using the clock outside the time zone of Germany, the DST automatic change time will be delayed or triggered earlier according to the time zone difference accordingly)
- Wall hanging or free standing
- Synchronized instant reception for outdoor weather data as well as radio controlled time signal

Features of wind sensor

The wind sensor measures wind speed and sends the data to thermo-hygro sensor, which in turn transmits the data to the base station.

Feature of rain sensor

The rain sensor measures the rainfall and sends the data to thermo-hygro sensor, which in turn transmits the data to the base station. Operating power is taken from the thermo-hygro sensor by a cable connection

3. Set up Guide

3.1 Battery install

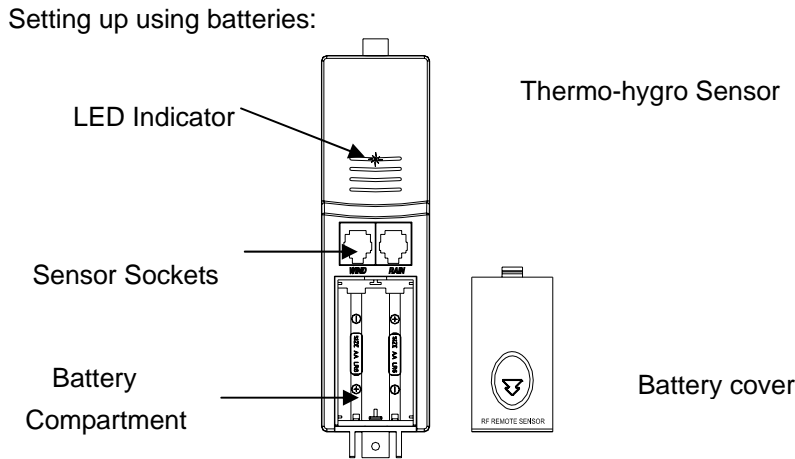

Note: To avoid operating problems, please take note of battery polarity before/when inserting any Alkaline Batteries. Use good quality Alkaline Batteries and avoid rechargeable batteries. Since the radio controlled time receiver is built inside the sensor, please do not put the sensor close to area with mass metal or obvious shielding objects around.

- 1) Pull away the shower proof casing of the thermo-hygro sensor to reveal the two sockets (for the wind sensor and rain sensor)
- 2) Connect the attached cables of wind and rain sensors to the corresponding sockets of the thermo-hygro sensor by clicking them into place. Make sure that rain and wind sockets not swapped when plugging the phone jacket.
- 3) Open the base station's battery cover located at the back of the unit and insert 3 x AA, 1.5V Alkaline batteries into the battery compartment and close the battery cover
- 4) Open the battery cover of the thermo-hygro sensor located below the two sockets and insert 2 x AA, 1.5V Alkaline batteries and close the cover

Every time the thermo-hygro sensor is powered up (for example after a change of batteries), the LED indicator will light up for 4 seconds (if no LED light up or is lighted permanently, make sure the battery is inserted the correct way or a proper reset is happened). After the thermo-hygro sensor is powered up, the sensor will transmit weather data for 24s, and then the sensor will start radio controlled time reception. During the RCC time reception period (maximum 5 minutes), no weather data will be transmitted. The LED indicator will be blinking 5 times once RCC signal was synchronized and the LED indicator will not light during any future regular RCC reception routines. Regular RF link will be established once RCC reception routine is finished.

When the base station is powered up, a short beep will sound and all LCD segments will light up for about 3 seconds before it enters into learning mode to learn the sensors security code.

Note: DO NOT PRESS ANY KEY during the first 10 minutes learning period or before radio controlled time is displayed on the receiver. After both outdoor weather data and radio controlled time are displayed you can place your remote sensor outdoors and set your time (if no RCC reception is possible). If there is no temperature reading in the indoor station, make sure the units are within range of each other or repeat the battery installation procedure. If a key is pressed before the weather station receives the temperature signal, you will need to follow the battery installation procedure again. **Please wait minimum 10seconds before**

re-insert the battery again to make a proper reset for both transmitter and receiver.

Note : If a battery change on the transmitter side happened, the base station will be resynchronized to the transmitter again within the next 3 hours. If you want to shorten the receiving data time, the base station has to re-install the battery so that it can have the new security code learnt right way, but the previous weather data and alarm value settings in base station will be lost.

Note for Radio Controlled Time DCF:

The time and date display is based on the signal provided by the highly accurate government operated atomic clock. The outdoor sensor will continue to scan for the radio controlled time signal each day despite it being manually set. If reception has been unsuccessful, then the radio controlled time icon will not appear but reception will still be attempted continually. If reception has been successful, the received time and date will overwrite the manually set time and date. **If your time zone is not at UTC+1:00, then manually set the time zone so that your clock time will be updated correctly after radio controlled time is received.**

Note:



When batteries require replacement for the base station, the low battery indicator will light up on the LCD.

Please participate in the preservation of the environment by properly disposing of all used-up batteries and accumulators at designated disposal points. Never dispose of batteries in a fire as this may cause explosion, risk of fire or leakage of dangerous chemicals and fumes

3.2 Mounting

1) Base station

With one foldable leg at the back of the unit, the base station can be placed onto any flat surface or wall mounted at the desired location by the hanging holes also at the back of the unit. It is important to check that outdoor sensor data can be received before permanently mounting any of the units

2) Remote sensor

For accurate results, the remote sensor mast should be securely mounted onto a horizontal surface and in an open area away from trees or other coverings where rainfall or wind speed may be reduced causing inaccurate reading

a). mounting the wind sensor onto a mast

Firstly, check that the wind-fan can rotate freely before fixing the unit. The wind sensor should now be mounted using the screw onto a mast provided to allow the wind to travel around the sensor unhindered from all directions.

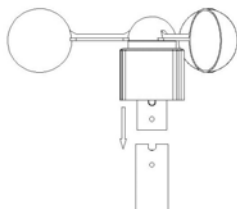

Front

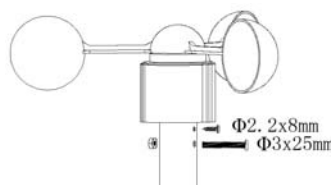

Back

b.) Mounting the rain sensor

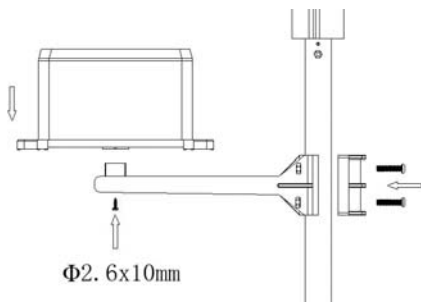

c.) Thermo-hygro sensor with solar panel

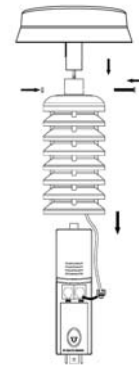

d.) Mounting the thermo-hygro sensor same as rain sensor

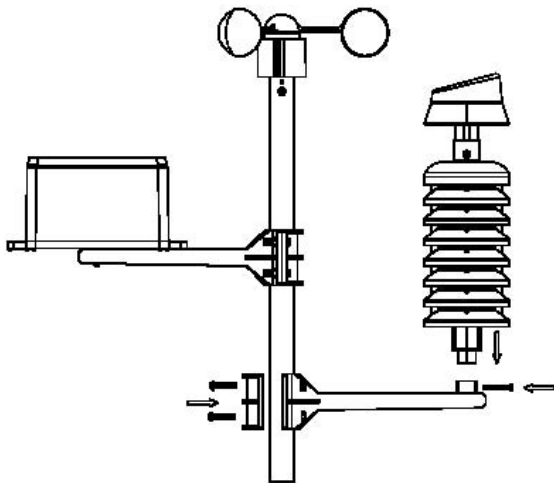

d.) Fix the whole set to a pole with the two adjustable hoops.

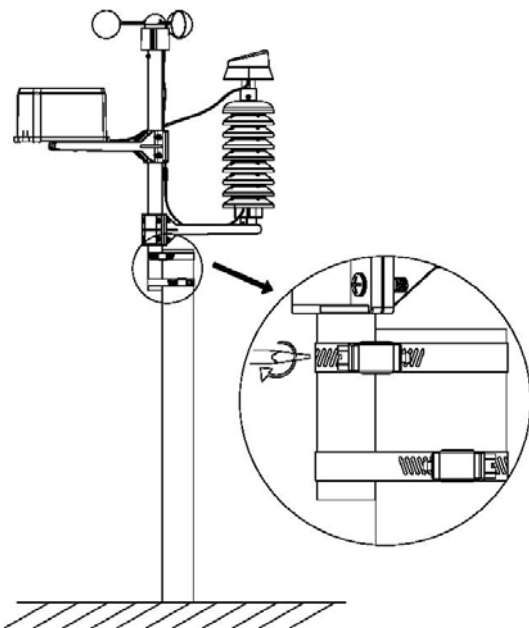

Once the wind sensor and rain sensor are fixed onto the mast, connect the cable to the corresponding thermo-hygro sensor socket.

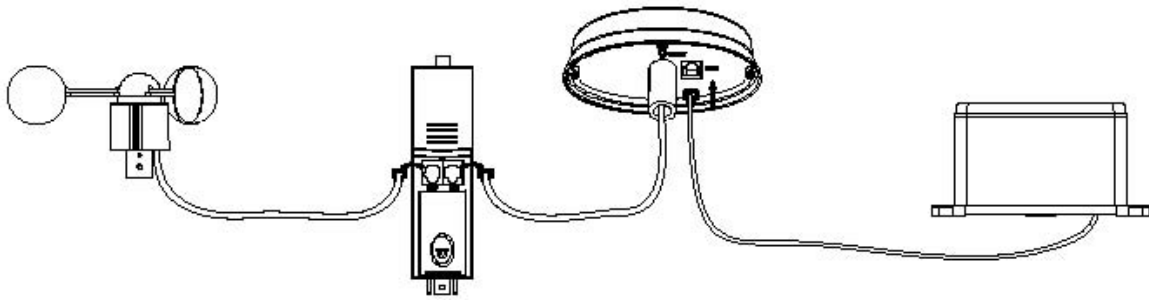

- The anemometer's cable is connected to the input marked **Wind** on the thermo-hygro sensor
- The rain sensor's cable is connected to the input marked **Rain** on the solar panel
- The solar panel's cable is connected to the input marked **Rain** on the thermo-hygro sensor.

The solar transmitter

The solar transmitter makes use of solar energy to power the instruments they are connected to.

Note: It use AA size rechargeable batteries. For the solar transmitters to function properly, make sure the solar receptors on the transmitters are exposed to sunlight and the connectors of the connection cable are securely plugged in.

For best results, direct solar panel as follows:

Solar panel facing north if you reside in the southern hemisphere; Solar panel facing south if you reside in the northern hemisphere.

4. LCD overview

4.1 LCD overview

The following illustration shows the full segments of the LCD for description purposes only and will not appear like this during normal operation and use.

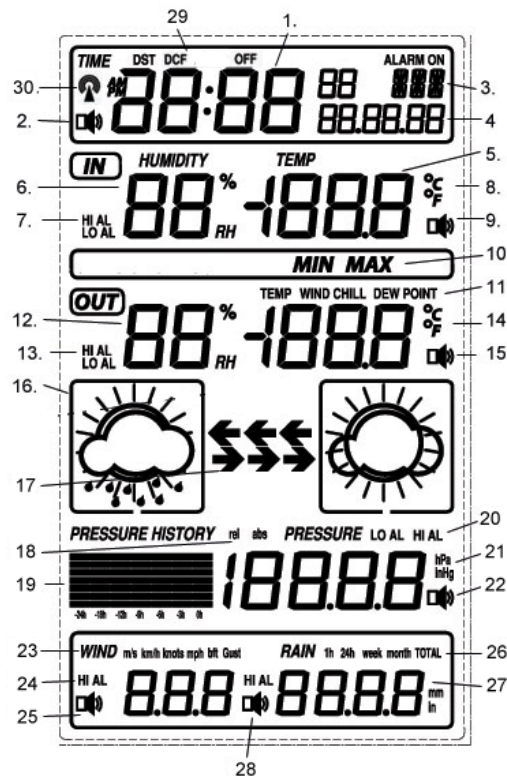

1. Time
2. Alarm on indicator
3. Day of week/ time zone / history
4. Date
5. Indoor temperature display
6. Indoor humidity display
7. Indoor temperature and humidity low alarm and high alarm
8. Temperature display unit
9. General indoor alarm icon
10. MIN/MAX information
11. Wind chill and dew point temperature display
12. Outdoor temperature and humidity display
13. Outdoor temperature and humidity low alarm and high alarm
14. Temperature display unit
15. General outdoor alarm icon
16. Weather forecast icon
17. Weather tendency indicator
18. Pressure unit (relative or absolute)
19. Pressure with 24 hour history graph
20. Pressure low alarm and high alarm
21. Pressure display unit (inHg or hPa)
22. Pressure alarm on indicator
23. Wind speed display unit (m/s, km/h, knots, chill mph, bft)
24. Wind speed high alarm
25. Wind alarm on indicator
26. Rainfall 1h, 24h, week, month or total hour display
27. Rainfall display unit (mm/in)
28. Rainfall alarm on indicator
29. Radio controlled time version DCF
30. Radio controlled time icon

4.2 Weather forecasting

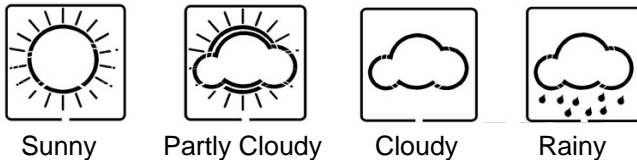

The four weather icons Sunny, partly Cloudy, Cloudy and Rainy represent the weather forecasting. For every sudden or significant change in air pressure, the weather icons will update accordingly to represent the change in weather.

4.3 Weather forecast tendency indicator

The weather tendency indicators arrow is located between the weather icons to show the air pressure tendency and provide a forecast of the weather to be expected by the decreasing or increasing air pressure. The rightward arrow means that the air pressure is increasing and the weather is expected to become better. The leftward arrow means that the air pressure is decreasing and the weather is expected to become worse.

The change of weather forecast icon is in accord to the relationship between current relative pressure and the pressure change since last twelve hours. If the weather is changing, weather tendency indicator (animated arrows) will be flashing. And after the next three hours if weather conditions have become stable, the arrows will fix indicating a stable condition happened.

Examples of changing weather icons:

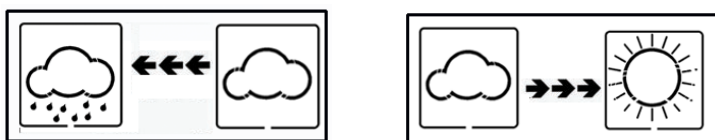

4.4 Storm warning indicator

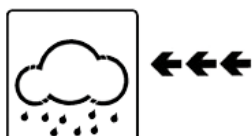

The storm threshold can be set to suit the user's requirement for storm forecasting from 3-9hPa (default

4hPa). When there is a fall over pressure threshold within 3 hours, the storm forecasting will be activated, the clouds with rain icon and tendency arrows will flash for 3 hours indicating the storm warning feature has been activated.

Notes to pressure sensitivity setting for weather forecasting:

The pressure threshold can be set to suit the user's requirement for weather forecasting from 2-4hPa (default 2hPa). For areas that experience frequent changes in air pressure requires a higher setting compared to an area where the air pressure is stagnant. For example if 4hPa is selected, then there must be a fall or rise in air pressure of at least 4hPa before the weather station will register this as a change in weather.

5. Program Mode

The base station has five keys for easy operation: **SET** key, **+** key, **ALARM** key, **HISTORY** key and **MIN/MAX** key. And there are five program modes available: Quick Display Mode, Setting Mode, Alarm Mode, History Mode and Min/Max Mode.

The program mode can be exited at any time by either pressing the **HISTORY** key, or waiting for the 30-second time-out to take effect.

5.1 Quick Display Mode

- While in Normal Mode, press the **SET** key to enter the Quick Display Mode as follow:

1. Outdoor Temperature / Wind chill / Dew point (press the **+** key or **MIN/MAX** key shifts the display between outdoor temperature, wind chill and dew point)
2. Absolute pressure / Relative pressure (press the **+** key or **MIN/MAX** key shifts the display between the absolute pressure and relative pressure)
3. Wind speed / Gust speed (press the **+** key or **MIN/MAX** key shifts the display between the wind speed and gust speed)
4. 1 hour/ 24 hour / week/ month / total rainfall quantity (press the **+** key or **MIN/MAX** key shifts the display between the selectable rainfall quantities), while display the rainfall total quantity, pressing the **SET** key for two seconds will reset the rainfall total value to zero and the time recording to current time.

- Press the **SET** key to accept the change and advance to the next display mode. Continue to press the **SET** key to toggle through the display mode until return to the normal Mode

5.2 Setting Modes

- Press the **SET** key for 3 second while in normal mode to enter the normal Setting mode

- Press the **SET** key to select the following setting in sequence :

1. Time Zone Setting
2. 12/24 hour format
3. Manual time setting (hours/minutes)
4. Calendar setting(year /month/ date, weekday will be calculated thus no need to set weekday)
5. Temperature display unit degree Celsius or Fahrenheit
6. Air pressure display units in hPa or inHg
7. Relative pressure setting from 919.0hPa – 1080.0hPa (default 1013.2hPa)
8. Pressure threshold setting (default 2hPa)
9. Storm threshold setting (default 4hPa)
10. Wind speed and gust display units in km/h, mph, m/s, knots, bft
11. Rainfall display units in mm or inch

- In the setting modes, press **+** key or **MIN/MAX** key to select the units or scrolls the value. Holding the **+** key or **MIN/MAX** key for 3 second will increase/decrease digits in great steps.

- Press **HISTORY** key or key idle 30 second, the setting mode will return to Normal Mode

Note: Please set the units firstly before change units' value. During change of units setting, the previous set value will be changed according to the new units. However it might cause resolution loss due to its internal calculation algorithm.

5.3 History Modes

- While in Normal Mode, press the **HISTORY** key to enter the History Mode.
- In the History Mode, press the **+** key to select the record over the past 24hours at increments of -3 hours, -6 hours, -9 hours, -12 hours, -15 hours, -18 hours, -21 hours, -24 hours
- Press the **HISTORY** key or key idle 10 second to return to Normal Mode

5.4 Alarm Modes

- While in Normal Mode press the **ALARM** key to enter the High Alarm Mode
- Press the **ALARM** key again to enter Low Alarm mode

Remark: after the initial pressing of **ALARM** key, the display will be refreshed to show current high, low alarm values. Normal alarm value will be displayed only for those already activated, all other not activated values will be displayed with "--" or "- -" instead.

- Press the **ALARM** key again to return the Normal Mode
- In the High Alarm Mode press the **SET** key to select the following alarm modes:
 1. Time alarm (at low alarm setting mode, the same time alarm setting sequence will repeat)
 2. Indoor humidity high alarm
 3. Indoor temperature high alarm
 4. Outdoor humidity high alarm
 5. Outdoor temperature high alarm
 6. Wind chill high alarm
 7. Dew point high alarm
 8. Pressure high alarm
 9. Wind speed high alarm
 10. Gust speed high alarm
 11. 1Hour rain high alarm
 12. 24 hour rain high alarm
- In the Low Alarm Mode press the **SET** key to select the following alarm modes:
 1. Time alarm (at high alarm setting mode, the same time alarm setting sequence will repeat)
 2. Indoor humidity low alarm
 3. Indoor temperature low alarm
 4. Outdoor humidity low alarm
 5. Outdoor temperature low alarm
 6. Wind chill low alarm
 7. Dew point low alarm
 8. Pressure low alarm
- In the alarm modes, Press **+** key to changes or scrolls the value upward, or press **MIN/MAX** key to change or scrolls the alarm value downward. Hold the **+** key or **MIN/MAX** key for 3 second to change the number in great step. Press the **ALARM** key to choose the **alarm on** or **off** (if alarm is enabled, the speaker icon on the LCD will be turned on indicating the alarm function has been enabled). Press the **SET** key to toggle through each alarm mode until it returns to the normal display mode.
- Press **HISTORY** key or key idle 30 second at any time, the alarm mode will return to Normal Mode

Canceling the Temperature Alarm While Sounding

a. When a set weather alarm condition has been triggered, that particular alarm will sound for 120 second and flash until the weather condition doesn't meet the user set level. Press any key to mute the alarm. When weather alarm condition was activated again within 10 minutes, alarm will not sound but will continue to flash until weather conditions have become more steady. This feature is useful to avoid repeated triggering for the

same alarm value.

b. The alarm will reactivate automatically once the value has fallen below the set value.

The outdoor weather alarm

When a set outdoor weather alarm has been triggered, it will flash on the LCD display and the general outdoor alarm icon and high/low alarm icon will flash accordingly. For example, in outdoor temperature display mode, when dew point high alarm is triggered **DEW POINT** icon will flash along with general outdoor alarm icon and high alarm icon flashing, telling that the current alarm source is from dew point.

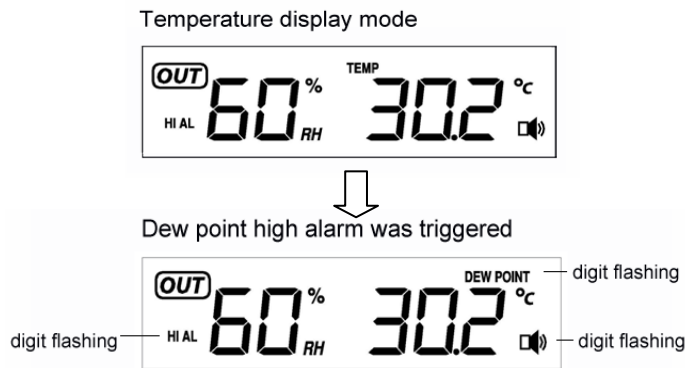

5.5 Min/Max Mode

- While in Normal Mode, press the **MIN/MAX** key to enter the maximum mode,
- Press **MIN/MAX** key again to enter the minimum mode
- Press **MIN/MAX** key again to return the Normal Mode
- In the maximum reading Mode, press the **+** key to display the following maximum values together with the time and date stamp when these values were recorded, if press **SET** key in the following individual maximum value will be reset to current reading together with the current time and date.
 1. Indoor humidity maximum
 2. Indoor temperature maximum
 3. Outdoor humidity maximum
 4. Outdoor temperature maximum
 5. Wind chill temperature maximum
 6. Dew point temperature maximum
 7. Pressure maximum
 8. Wind speed maximum
 9. Gust speed maximum
 10. 1Hour rain maximum
 11. 24 hour rain maximum
 12. Week rainfall maximum
 13. Month rainfall maximum
- In the minimum reading Mode, press the **+** key to display the following minimum values together with the time and date at which these values were recorded, if press **SET** key in the following individual minimum value will be reset to current reading together with the current time and date.
 1. Indoor humidity minimum
 2. Indoor temperature minimum
 3. Outdoor humidity minimum
 4. Outdoor temperature minimum
 5. Wind chill temperature minimum
 6. Dew point temperature minimum
 7. Pressure minimum

- Press the **HISTORY** key or key idle 10 second, the Min/Max mode will return to Normal Mode

6. Problems and interference with operation

Problem & cause	Remedy
Distance between transmitters and receiver too long	Reduce distance between transmitters and receiver to receive signal
High shielding materials between the units (thick walls, steel, concrete, isolating aluminum foil and etc.)	Find a different location for sensors and/or receiver. See also item 'transmission range' below
Interference from other sources (e.g. wireless radio, headset, speaker, etc. operating on the same frequency)	Find a different location for the sensors and/or base station. Neighbors using electrical devices operation on the same signal frequency can also cause interference with reception
No reception after adding extension cables	Find a new location for the sensors and/or base station.
Poor contrast LCD or no reception or low batteries in sensors or receiver	Change batteries
Temperature, humidity, or air pressure is incorrect.	Check/replace batteries. If multiple remote sensors are in use, check location with corresponding "boxed numbers". Or move away from sources of heat/cold. Adjust relative air pressure to a value from a reliable source (TV radio, etc.).

7. Specifications

Outdoor data

Transmission distance in open field	: 100meter max.
Frequency	: 433MHz
Temperature range	: -30°C to +65°C (show OFL if outside range)
Resolution	: 0.1°C
Measuring range rel. humidity	: 10%~99%
Rain volume display	: 0 - 9999mm (show OFL if outside range)
Resolution	: 0.3mm (if rain volume < 1000mm) 1mm (if rain volume > 1000mm)
Wind speed	: 0~180km/h (show OFL if outside range)
Measuring interval thermo-hygro sensor	: 48 sec
Water proof level	: IPX3

Indoor data

Pressure / temperature	: 48 sec
Indoor temperature measure range	: 0°C to +60°C (reading range: -20°C to +65°C)
Resolution	: 0.1°C
Measuring range rel. humidity	: 10%~99%
Resolution	: 1%
Measuring range air pressure	: 300-1100hPa (8.85-32.5inHg)
Accuracy	: +/-3hpa under 700-1100hPa
Resolution	: 0.1hPa (0.01inHg)
Alarm duration	: 120 sec

Power consumption

Base station	: 3XAA 1.5V LR6 Alkaline batteries
Remote sensor	: 2xAA 1.5V LR6 Alkaline batteries
Battery life	: Minimum 12 months for base station Minimum 24 months for thermo-hygro sensor

Remark: where outdoor temperature is lower than -20°C , make sure proper type of batteries to be used to assure that the device can get enough power to maintain its function properly. Normal alkaline batteries is not allow to be used since when outdoor temperature is lower than -20°C , the battery's discharging capability is greatly reduced.



Please help in the preservation of the environment and return used batteries to an authorized depot.

All rights reserved. This handbook must not be reproduced in any form, even in excerpts, or duplicated or processed using electronic, mechanical or chemical procedures without written permission of the publisher.

This handbook may contain mistakes and printing errors. The information in this handbook is regularly checked and corrections made in the next issue. We accept no liability for technical mistakes or printing errors, or their consequences.

All trademarks and patents are acknowledged.

Changes or modifications not expressly approved by the party responsible for compliance could void the user's authority to operate the equipment.