

**PROFESSIONAL WEATHER STATION
(WIND AND AIR PRESSURE)**

Operation Manual

About this manual

Thank you and congratulations on selecting this professional weather station! We are positive you will enjoy the benefits of accurate weather readings that our instruments offer.

This manual will guide you step-by-step through setting up your device. Use this manual to become familiar with your professional weather station, and save it for future reference.

Glossary of Common Terms

LCD

“LCD” is an acronym for “Liquid Crystal Display”. This is a common type of display screen used in televisions, computers, watches, and digital clocks.

BAROMETER & BAROMETRIC PRESSURE

A barometer is a device that measures the pressure of the air pushing on it—this measurement is called the barometric pressure. We don’t actually feel the barometric pressure because the air pressure is pushing equally in every direction.

RELATIVE AIR PRESSURE

Relative air pressure is the same as the barometric pressure. The calculation of relative air pressure is a combination of the absolute air pressure and the altitude.

ABSOLUTE AIR PRESSURE

Absolute air pressure is the actual air pressure on the barometer without regard to altitude.

INCHES OF MERCURY (inHg)

Inches of Mercury is the common unit of measurement for air pressure in the United States.

HECTOPASCALS (hPa)

Hectopascals are the common units of measurement for air pressure in the International System (SI) of measurement. The hectopascal holds the same value

Important Note:

The Professional weather station includes a base station (receiver), a transmitter unit, one wind direction sensor, one wind speed sensor, one rain gauge, USB cable and a PC software package on CD-ROM.

An added feature of the Weather Station is the readout of all measured and displayed time and weather data on a PC.

OVERVIEW

Display console

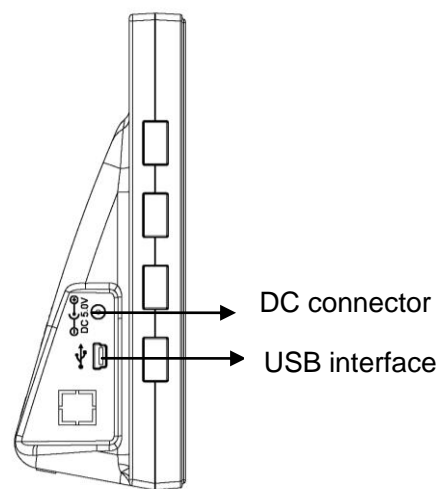
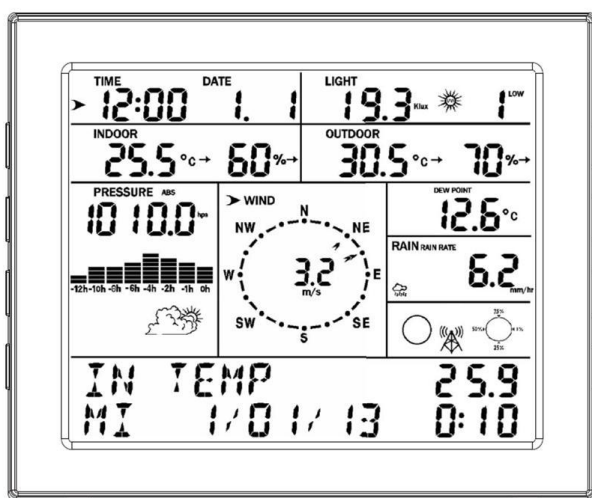

QTY	Item
1	Display Console
1	Outdoor sensor(Thermo-hygrometer with solar panel / Rain Gauge / Wind Speed Sensor/ Wind Direction)
1	CD contains PC software
1	Pole
1	pole mounting clamps
1	User manual
2	AA rechargeable batteries

Note:

Adaptor is not included.

Features

- Time and date, Moon phase.
- Indoor temperature and humidity
- Outdoor temperature and humidity
- Wind chill, wind direction.
- Rainfall
- Display rain level and rainfall data in 24 hours, one week, one month, one year, total rain and rainfall event.
- Wind speed in mph, km/h, m/s, knots or Beaufort
- The direction of the wind with 360 degree
- Wind chill, dew point and heat index temperature display.
- Barometric, weather forecast.
- MAX, MIN value with time stamp.

- High/ low alarm.
- With message panel showing indication of alarms/Min/Max data, with time stamps
- Light and UV index
- Save the data when batteries are changed
- PC software
- Upload the data to internet (optional)

Set up Guide

Before placing and installing all components of the weather station at their final destination, please set up the weather station with all parts being nearby for testing the correct function.

Setting up the base station and transmitter

Setting up using batteries:

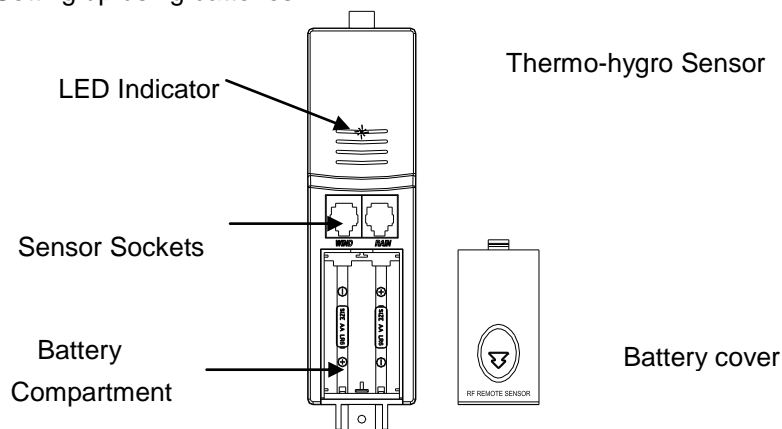

- 1) Insert 2XAA 1,5V alkaline rechargeable batteries first into the battery compartment of the remote sensor and immediately afterwards 3XAA 1,5V alkaline batteries in the base station, observing the correct polarity. When battery is first inserted, the red LED light on the remote sensor will be light up for 3-4 seconds. (If no LED light up or is lighted permanently, make sure the battery is inserted the correct way or a proper reset is happened)
- 2) When the base station is powered up, the LCD display activates for 3 seconds and after the “Beep”, it begins measuring indoor temperature, humidity and air pressure. The unit then enter the RF(Radio Frequency) state, where it receives data from the remote sensor.

RF (Radio Frequency) Receiving Mode

1. After power-on, the weather station enters RF receiving state for 180s
2. Base station receive the temperature, humidity, wind speed and rain data each 48s, receive illuminance data each 60s. If there is no new effective signal from the sensor in constance reception failure in 10minutes, the outdoor temperature and humidity will display “----”. If base

station didn't receive the signal in 240 minutes, the base station will start search and register new sensor.

3. If the outdoor data lost or a battery change for the transmitter, press the reset button on the solar power cabinet to re-send the signal and set the reregister on at display console to register new transmitter.

4. Do not press any key before outdoor sensor data received, otherwise the outdoor sensor learning mode will be terminated. When outdoor transmitter has been registered, the base station will automatically switch to the normal display mode from which all further settings can be performed by the user.

5. If there is no temperature reading in the base station, make sure the units are within range of each other or repeat the battery installation procedure.

Note:

Commonly the radio communication between receiver and transmitter in the open field can reach a distance of up to 330 feet providing that there are no interfering obstacles such as buildings, trees, vehicles, high voltage lines, etc.

Radio interferences such as PC screens, radios or TV sets can, in bad cases, entirely cut off radio communication. Please take this into consideration when choosing standing or mounting locations.

Mounting the sensor

Important Notes:

On the edge of wind direction sensor, there are four alphabet letter of "N","E","S"and "W" representing for the direction of North, East, South and West. Wind direction sensor has to be adjusted so that the directions on the sensor are matching with your real location. Permanent wind direction error will be introduced when the wind direction sensor is not positioned correctly during installation.

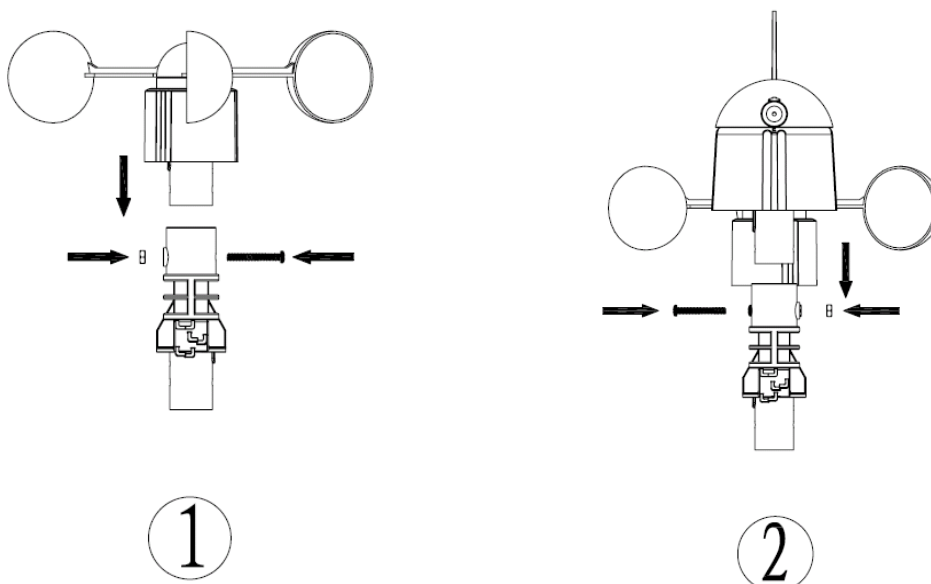

Anemometer

wind direction sensor

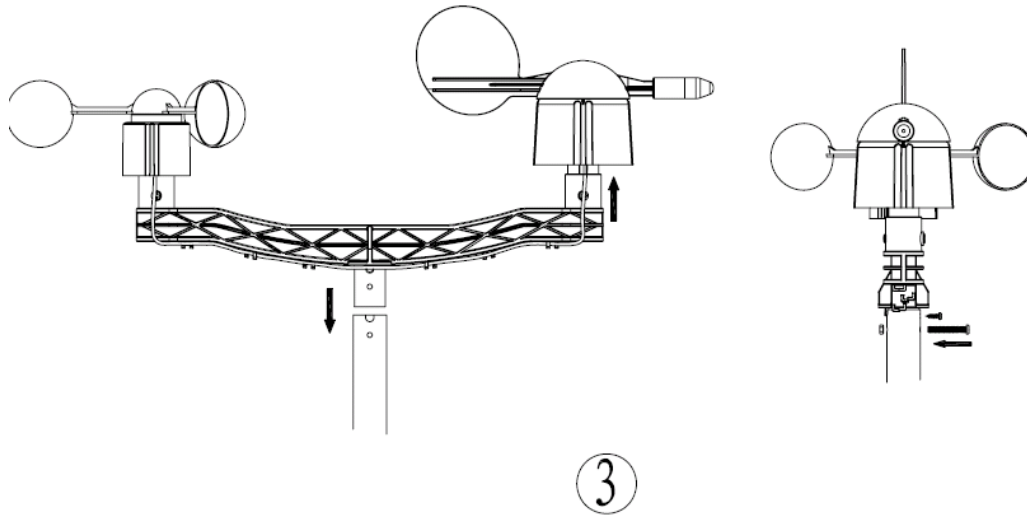

Mounting the dual wind sensor holder

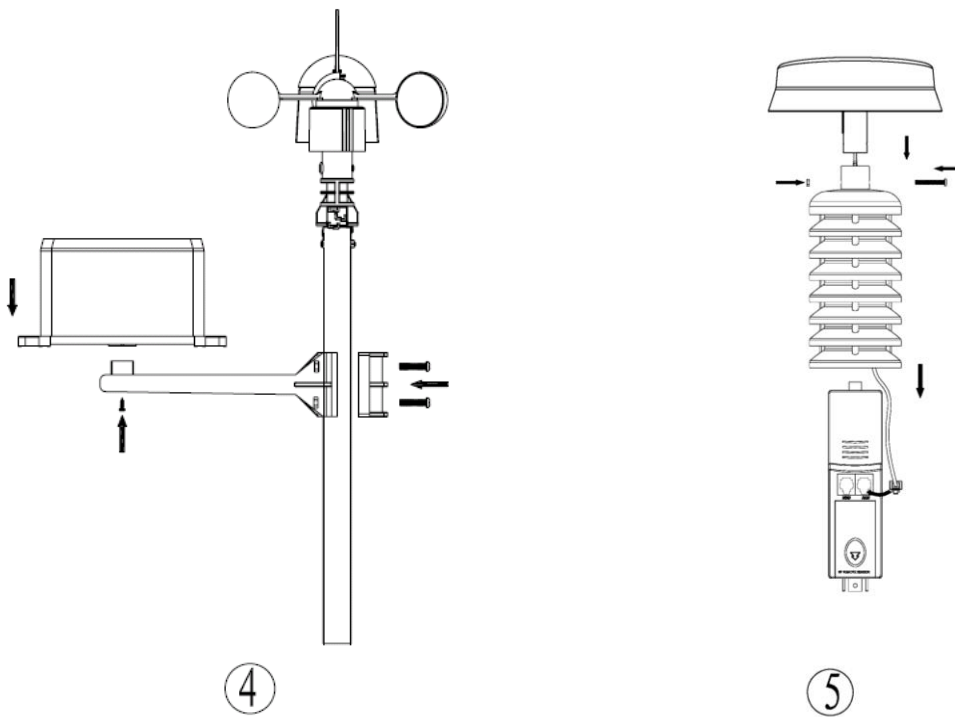

Mounting the rain sensor

Thermo-hygro sensor with solar panel

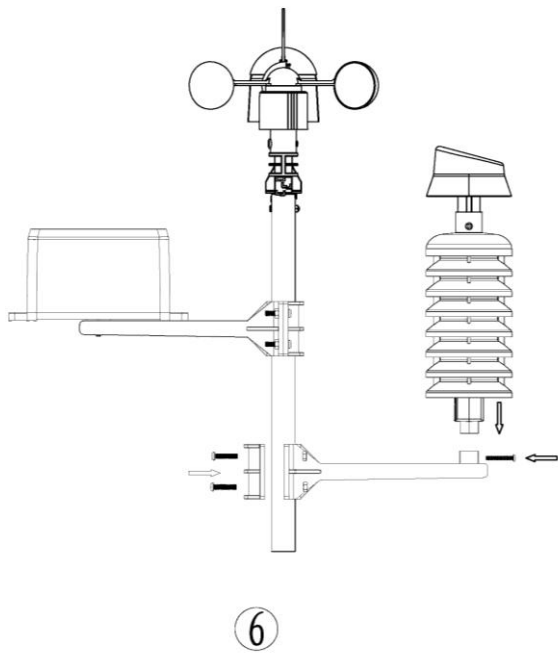

Mounting the thermo-hygro sensor
 Fix the whole set to a pole
 same as rain sensor
 with the two adjustable hoops.

- The anemometer's cable is connected to the input on the wind direction sensor.
- The wind direction sensor's cable is connected to the input marked **Wind** on the thermo-hygro sensor
- The rain sensor's cable is connected to the input marked **Rain** on the solar panel
- The solar panel's cable is connected to the input marked **Rain** on the thermo-hygro sensor.

The solar transmitter

The solar transmitter makes use of solar energy to power the instruments they are connected to.

Note: It use AA size alkaline rechargeable batteries. For the solar transmitters to function properly, make sure the solar receptors on the transmitters are exposed to sunlight and the connectors of the connection cable are securely plugged in.

For best results, direct solar panel as follows:

Solar panel facing north if you reside in the southern hemisphere; Solar panel facing south if you reside in the northern hemisphere.

Display Unit

1. Display Console Layout

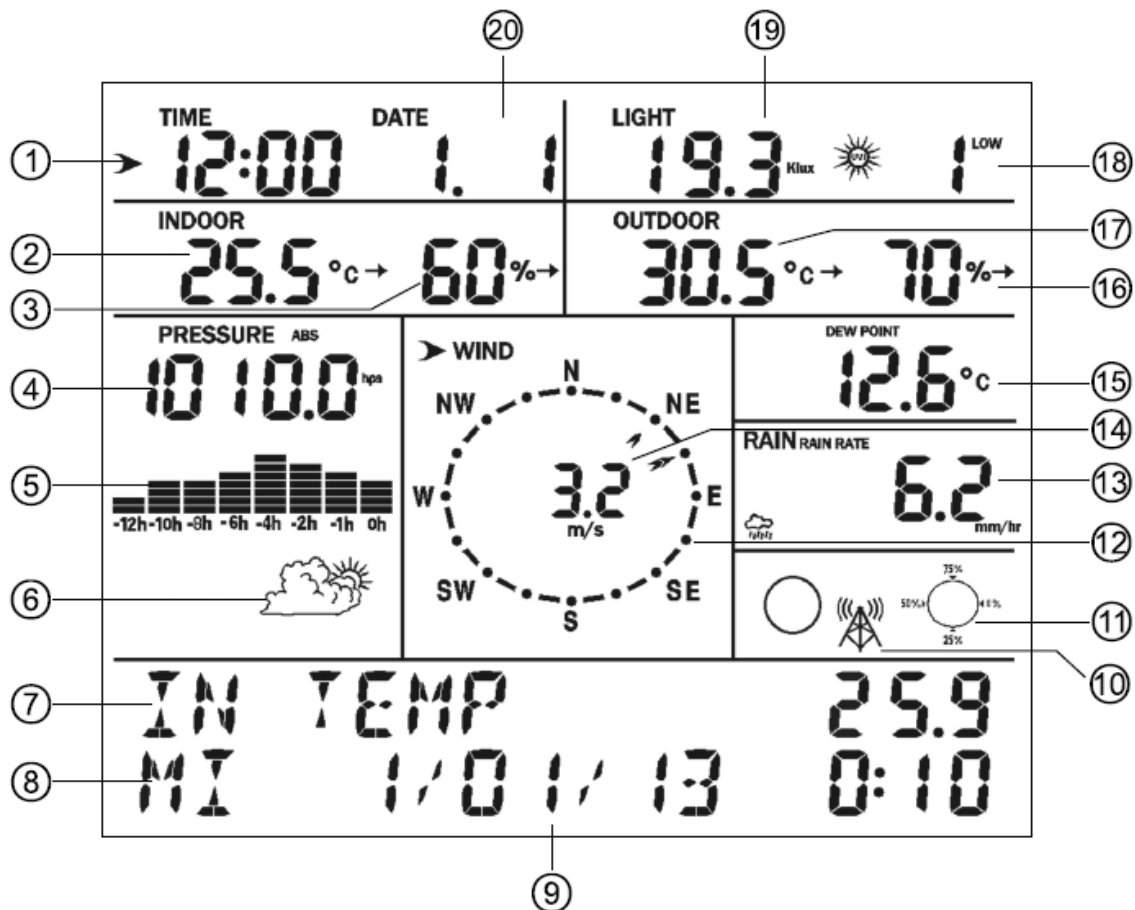

1.Time	2.Indoor Temperature
3.Indoor Humidity	4.Barometric Pressure
5. Barometric Pressure graph	6.Weather icon
7. Message panel showing indication of alarms/Min/Max data	8. Minimum
9.Time stamp	10.RF signal
11.Memory status	12.Wind direction
13.Rain fall	14.Wind speed
15.Dew point	16. Outdoor humidity
17.Outdoor Temperature	18.UV
19.Light	20.Date

2.Initial Display Console Set Up

2.1 The unit will turn on all segments of the LCD for 3 seconds after power on and display setting value. Then the unit will start to register the outdoor channel which takes 3 minutes.

2.2 Full display

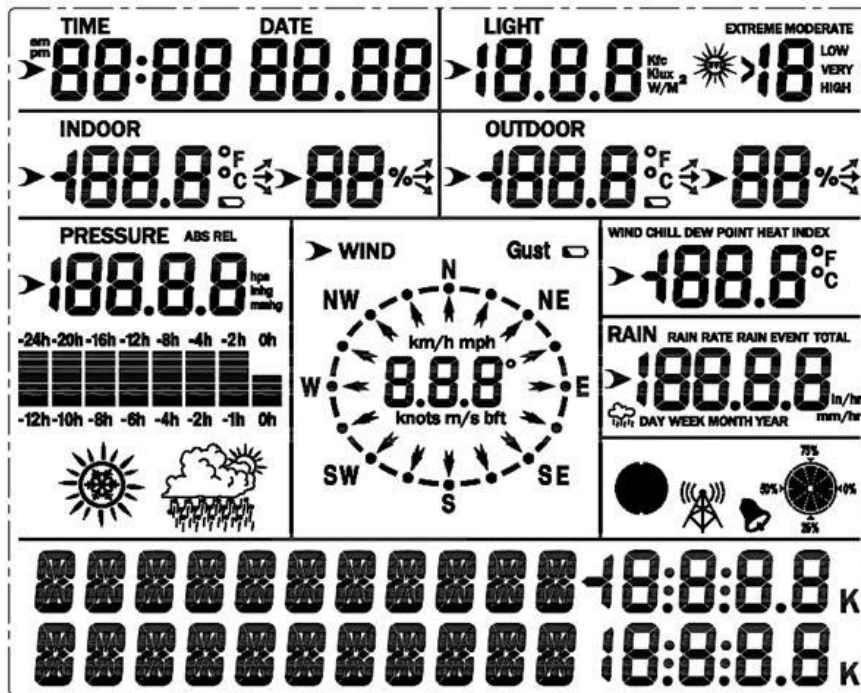

2.3 Key function

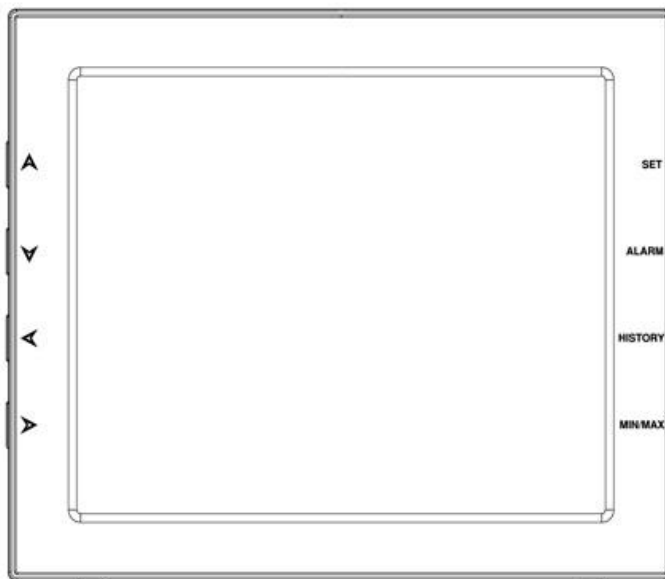

- SET: Enter the setting mode
- HISTORY: Display history records / return to normal mode
- ALARM: Display high or low alarm function / turn on/off the alarm
- MAX/MIN: Display the MAX, MIN value
- ▲: Increase the setting parameter/ Move to next message of the selected segment on the message panel
- ▼: Decrease the setting parameter/ Move to previous message of the selected segment on the message panel
- ▲: Move to previous segment/move to main menu during setting.
- ▼: Move to next segment/ move to sub menu during setting.

Console Operation

Program mode

The screen is divided into 10 segments for selection and there are message display panel on the bottom.

There are six program modes: normal, setting mode, history mode, alarm mode, max/min mode and calibrated mode.

All the modes can be exited at any time by pressing the HISTORY key, or waiting for a 30 second timeout to take effect.

Normally, if the segment selected has multi parts, press SET key to choose different part. Example: the current section is RAIN, you can press SET key to select among RAIN RATE, RAIN EVENT, DAY, WEEK, MONTH, YEAR and TOTAL.

1. Quick Display Mode(Update every 5 Seconds)

In the normal mode and once some segment is selected (Different segments can be chosen by pressing "◀" or "▶" key. And the default selected segment is **time and date**), there will be messages take turns to show on the message panel. If there are alarms occurred, the alarm information will be displayed in real time as well. The messages are showing one by one automatically or you can transfer by pressing "▲" or "▼" button.

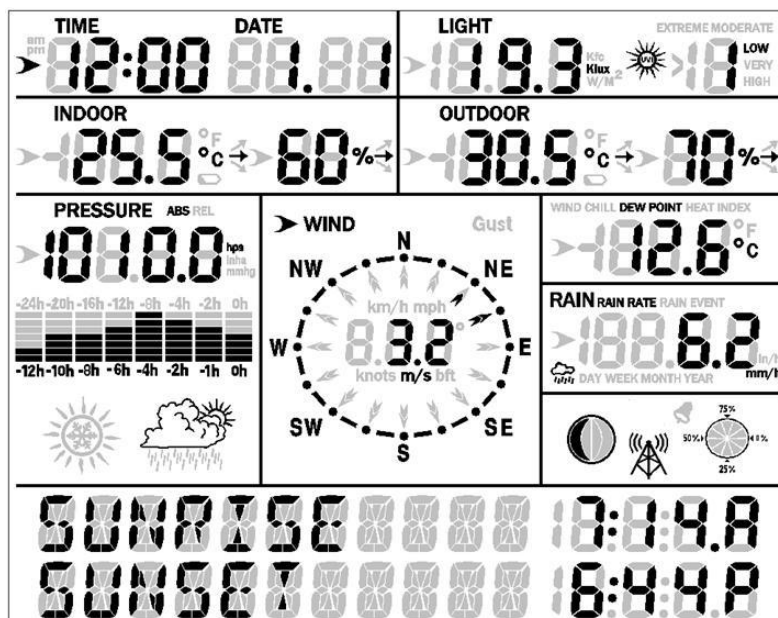

- Note: Press ▲ fast switch to next message
- Press ▼ fast switch to previous message.
- Press ◀ or ▶ select segments.

- Time and date



- a) Week and year (TUESDAY 2013)
- b) Alarm time
- c) Moon phase. (see moon phases part illustration on Page 19)
- d) The DST flag is ON, will display "DAYLIGHT SAVING TIME".
- e) If device is connected to outdoor transmitter successfully, it will display transmitter ID for 120 second.

- Light and UVI

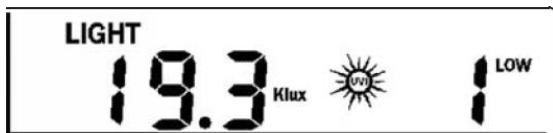

- a) The max light of the day.
- b) The max light since last reset
- c) The max UVI of the day.
- d) The max UVI since last reset.

- Indoor temperature

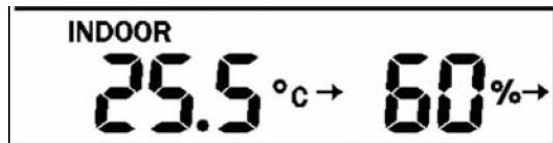

- a) The max and min temperature/ humidity of the day.
- b) The max and min temperature/ humidity since reset.

- Outdoor temperature/ humidity

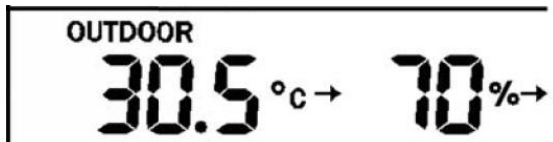

- a) The max and min temperature/ humidity of the day
- b) The max and min temperature/ humidity since last reset.

- Barometric



- a) The max and min absolute barometric of the day
- b) The max and min absolute barometric since last reset.
- c) The max and min relatively barometric of the day
- d) The max and min relatively barometric since last reset.

- Wind and gust speed

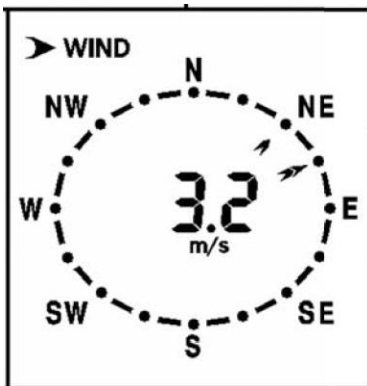

- a) The max wind speed of the day
- b) The max wind speed since last reset.
- c) The max gust of the day
- d) The max gust since last reset.

- Wind chill, dew point, heat index



- a) The max of dew point, heat index of the day.
- b) The min of wind chill, dew point of the day.
- c) The max of dew point, heat index since last reset.
- d) The min of wind chill, dew point since last reset.

- Rainfall



- a) The max Rainfall of rainfall rate of the day.

- b) The max Rainfall since last reset (including rainfall rate during 1 day, 1 week, 1 month, and 1 year).

2. Setting Mode

2.1 In normal mode, press SET key for 2 seconds to enter the setting mode.

Then press "◀" button, you will transfer among the main menu with options of :

TIME SETTING

UNIT SETTING

Record save interval

Rain sensor setting

Barometric setting

Contrast setting

Key Beep Setting

REREGISTER Transmitter

Calibration setting

Transmitter ID

IP address (this function is only available in Network version)

Choose one option and then press "▶" button, you will enter the sub menu.

Press ▲ / ▼ key to transfer the unit or change the value. Hold the ▲ / ▼ key for 2 seconds will increase/decrease digits in great steps. Press HISTORY key or wait for 30 seconds at any time, device will return to normal mode.

Sub menus of every option:

- TIME SETTING

- a) 12H/24H format select
- b) MM-DD-YYYY / DD-MM-YYYY / YYYY-MM-DD select
- c) Set time (hour, minute)
- d) Set clock (month, day, year)
- e) Time Zone select
- f) Daylight saving settings (DST ON/OFF)
- g) Set NORTH or SOUTH for moon phase
- h) RCC ON/OFF select (if have RCC function)

- UNIT SETTING

- a) Light unit select (lux, fc, w/m2)
- b) Temperature unit select (C, F)
- c) Pressure unit select (hpa, inhg, mmhg)
- d) Wind speed unit select (km/h, m/s, bft, mph, knots)
- e) Rainfall unit select (mm, inch)

- Save record interval time setting:16S, 32S, 48S, 1M, 2M, ..., 239M, 240M.

S; Seconds

M: Minute

- RAIN SEASON BEGIN (JAN, FEB, MAR, APR, MAY, JUN, JUL, AUG, SEP, OCT, NOV, DEC)

Default: January. The total rain falls before that will be cleared once it comes to 0:00 of January 1st. Means the new statistic annual of rain fall begins from 0:00 of January 1st. Users can choose from January to December

- PRESSURE SETTING

- a) Current weather setting.
- b) Select the synoptic chart, Pre-set the value of weather and Pre-storm value.
- c) Select the historical time coordinates of pressure graph.

- LCD contrast setting.

Level 1-9 for option. Default: 5. The higher the level is, the brighter the display is.

- KEY BEEP ON/OFF

- Register new transmitter(REREGISTER ON/OFF)

- Calibration setting

- a) LIGHT FACTOR

LUX index calibration coefficient: default 1. (Range is 0.1-10)

- b) UV FACTOR

UV factor calibration coefficient: default 1 (Range is 0.1-10)

- c) IN TEMP CORRECT

Indoor temperature can be calibrated within measuring range.

- d) IN HUMI CORRECT

Indoor humidity can be calibrated within measuring range.

- e) OUT TEMP CORRECT

Outdoor temperature can be calibrated within measuring range.

- f) OUT HUMI CORRECT

Outdoor humidity can be calibrated within measuring range.

- g) ABS PRESS CORRECT

Absolute pressure can be calibrated within measuring range.

- h) REL PRESS CORRECT

Relatively pressure be calibrated within measuring range.

- i) WIND DIR CORRECT

Wind direction can be adjusted by 0-359° .For southern hemisphere installations, the wind direction need to change by 180° .

j) WIND FACTOR

Wind speed calibration coefficient: default 1 (range is Range is 0.1-2.5)

k) RAIN FACTOR

Rain factor calibration coefficient: default 1 (range is Range is 0.1-2.5)

l) RAIN DAY CORRECT

Calibration for total rain falls of 1 day. (Range is 0-9999mm)

m) RAIN WEEK CORRECT

Calibration for total rain falls of 1 week (Range is 0-9999mm)

n) RAIN MONTH CORRECT

Calibration for total rain falls of 1 month (Range is 0-9999mm)

o) RAIN YEAR CORRECT

Calibration for total rain falls of 1 year (Range is 0-9999mm)

p) RAIN TOTAL CORRECT

Calibration for total rain falls since last reset. (Range is 0-9999mm)





● Transmitter ID

Display the transmitter ID.

2.2 ALARM SETTING MODE

In normal mode, press ALARM key you will enter high alarm mode, and press ALARM key again you will switch to low alarm mode.

● HIGH ALARM SETTING

Press   key to transfer among the different segments and press   key to adjust the value of the high alarm.

- a) TIME ALARM –Set time alarm.
- b) LIGHT HIGH ALARM --Set light high alarm
- c) UVI HIGH ALARM --Set UVI high alarm
- d) In TEMP HIGH ALARM --Set indoor temperature high alarm
- e) In HUMI HIGH ALARM --Set indoor humidity high alarm
- f) Out TEMP HIGH ALARM Set outdoor temperature high alarm
- g) Out HUMI HIGH ALARM Set outdoor humidity high alarm
- h) ABS BARO HIGH ALARM --Set absolute barometric pressure high alarm
- i) REL BARO HIGH ALARM --Set relatively barometric pressure high alarm
- j) WIND HIGH ALARM --Set wind speed high alarm
- k) GUST HIGH ALARM --Set gust speed high alarm

- l) DEW POINT HIGH ALARM --Set dew point high alarm
- m) HEAT INDEX HIGH ALARM --Set heat index high alarm
- n) RAIN RATE HIGH ALARM --Set rainfall rate high alarm
- o) RAIN DAY HIGH ALARM --Set rainfall day high alarm

- LOW ALARM SETTING

- a) In TEMP LOW ALARM--Set indoor temperature low alarm
- b) In HUMI LOW ALARM --Set indoor humidity low alarm
- c) In TEMP LOW ALARM --Set outdoor temperature low alarm
- d) Out HUMI LOW ALARM --Set outdoor humidity low alarm
- e) ABS BARO LOW ALARM --Set absolute barometric low alarm
- f) REL BARO LOW ALARM --Set relatively barometric low alarm
- g) WIND CHILL LOW ALARM --Set wind chill low alarm
- h) DEW POINT LOW ALARM --Set dew point low alarm

In alarm setting mode, you can press the SET key to choose turn on or/off the alarm. Press ALARM key, you can switch between high alarm and low alarm setting. Press HISTORY key or wait for 30 seconds at any time, you will return to normal mode.

When alarm occurs, the alarm information will be displayed in real time on the message panel. You can press any key to stop it. But the alarm ICON will still flash until the weather data doesn't meet the user set alarm level.

3. Max/Min Mode

In Normal Mode, press the MIN/MAX key to enter the max/min mode.

Press MIN/MAX select today max/history max /today min/history min.

Press </> key to enter the sub menu of the each 4 options and display the maximum or minimum values of each parameter together with the time and date stamp.

- Today max and total max:

Today max: The Maximum of 1 day

Total max: The Maximum of total since last reset

- a) LIGHT TODAY MAX, LIGHT TOTAL MAX-- Maximum Light
- b) UV TODAY MAX, UV TOTAL MAX-- Maximum UVI.
- c) IN TEMP TODAY MAX, IN TEMP TOTAL MAX -- Maximum Indoor temperature.
- d) IN HUMI TODAY MAX, IN HUMI TOTAL MAX -- Maximum Indoor humidity.
- e) OUT TEMP TODAY MAX, OUT TEMP TOTAL MAX – Maximum Outdoor temperature.
- f) OUT HUMI TODAY MAX, OUT HUMI TOTAL MAX -- Maximum Outdoor humidity.
- g) ABS BARO TODAY MAX, ABS BARO TOTAL MAX -- Maximum Absolute barometric.
- h) REL BARO TODAY MAX, REL BARO TOTAL MAX -- Maximum Relatively barometric.
- i) WIND SPEED TODAY MAX, WIND SPEED TOTAL MAX -- Maximum Wind speed.
- j) GUST SPEED TODAY MAX, GUST SPEED TOTAL MAX -- Maximum Gust speed.
- k) DEW POINT TODAY MAX, DEW POINT TOTAL MAX -- Maximum Dew point temperature.
- l) HEAT INDEX TODAY MAX, HEAT INDEX TOTAL MAX -- Maximum Heat index

temperature.

- m) RAIN RATE TODAY MAX, RAIN RATE TOTAL MAX -- Maximum Rainfall rate.
- n) RAIN 24H TOTAL MAX -- Maximum Rainfall within 24 hours.
- o) RAIN WEEK TOTAL MAX -- Maximum Rainfall within 1 week
- p) RAIN MONTH TOTAL MAX -- Maximum Rainfall within 1 month
- q) RAIN YEAR TOTAL MAX -- Maximum Rainfall within 1 year.

- Today min and total min:

Today min: The Maximum of 1 day

Total min: The Maximum of total since last reset

- a) IN TEMP TODAY MIN, IN TEMP TOTAL MIN -- Minimum Indoor temperature.
- b) IN HUMI TODAY MIN, IN HUMI TOTAL MIN -- Minimum Indoor humidity.
- c) OUT TEMP TODAY MIN, OUT TEMP TOTAL MIN -- Minimum Outdoor temperature.
- d) OUT HUMI TODAY MIN, OUT HUMI TOTAL MIN -- Minimum Outdoor humidity.
- e) ABS BARO TODAY MIN, ABS BARO TOTAL MIN -- Minimum Absolute barometric.
- f) REL BARO TODAY MIN, ABS BARO TOTAL MIN -- Minimum Relatively barometric
- g) WIND CHILL TODAY MIN, WIND CHILL TOTAL MIN -- Minimum Wind chill temperature
- h) DEW POINT TODAY MIN, DEW POINT TOTAL MIN -- Minimum Dew point temperature

Each Maximum/minimum value can be cleared by pressing SET key for 2 seconds during this mode.

Press the HISTORY key or wait for 30 seconds will lead to Normal Mode.

5. History mode

In normal mode, press the history key switch to history.

If no history data, it will show "HISTORY" and "NONE RECORD" on the message pane..

Otherwise it will display message like "HISTORY P/R 1.01" and "YEAR / SECOND 13.06".

P means PAGE, R means RECORD. 1 is PAGE No., 01 is record No.. Every page includes 32 records of history data.

"YEAR / SECOND 13.06". is a time stamp of the record. 13 means 2013 year, 06 is the second stamp. The hour, minute, and date stamp will be shown on the time segment.

Press the ▲/▼ key to switch to next/pre record.



Press the ◀/▶ key to switch to next/pre page record.

Other Console Functions

















- Weather Tendency indicators

There are tendency indicators besides the indoor/outdoor temperature and humidity segments. The standard of detection is as bellow:

Tendency		humidity	Temperature
----------	--	----------	-------------

indicators			
	Rising	Rising rate $\geq 10\%$ within 30 minutes	Rising $\geq 1^\circ\text{C}$ within 30 minutes
	Steady	Change rate $< 10\%$ within 30 minutes	Change rate $< 1^\circ\text{C}$ within 30 minutes
	Falling	Falling rate $\geq 10\%$ within 30 minutes	Falling $\geq 1^\circ\text{C}$ within 30 minutes

- **Moon Phases**

Icon: Northern Hemisphere	Moon Phase Description	Icon: Southern Hemisphere
	NEW MOON	
	WAXING CRESCENT MOON	
	FIRST QUARTER MOON	
	WAXING GIBBOUS MOON	
	FULL MOON	
	WANING GIBBOUS MOON	
	LAST QUARTER MOON	
	WANING CRESCENT MOON	

- **Beaufort Scales (Wind Speed)**

Wind speed	Beaufort number	Description
0-1mph (0-1.6kph)	0	Calm
1-3mph (1.6-4.8kph)	1	Light air
3-7mph (4.8-11.3kph)	2	Light breeze
7-12mph (11.3-19.3kph)	3	Gentle breeze
12-18mph (19.3-29.0kph)	4	Moderate breeze
18-24mph (29.0-38.6kph)	5	Fresh breeze
24-31mph (38.6-49.9kph)	6	String breeze
31-38mph (49.9-61.2kph)	7	Near gale
38-46mph (61.2-74.1kph)	8	Gale
46-54mph (74.1-86.9kph)	9	Strong gale
55-63mph (88.5-101.4kph)	10	Storm
64-73mph (103-117.5kph)	11	Violent storm
74mph or above (119.1kph)	12	Hurricane

Specification

- **Factory Default Settings**

- 1) Time: 1/1/2000 0:00:00 → 31/12/2099 23:59:59 (default: 1/1/2014 0:00 00 WED)
- 2) Time zone: -12 → +12
- 3) 12/24 hour format (default: 24hr)
- 4) DD-MM-YYYY / MM-DD-YYYY / YYYY-MM-DD format (default: DD-MM-YYYY)
- 5) Temperature unit C or F (default: C)
- 6) Wind speed units: km/h, m/s, bft, mph, knots (default: km/h)
- 7) Average wind speed / gust wind speed (default: average wind speed)
- 8) Pressure units: hpa, mmHg, inHg (default: hpa)
- 9) Weather forecast: 2, 3, 4 (default: 2)
- 10) Storm: 3→9 (default: 4)
- 11) Time format of history graph: 12h, 24h (default: 12h)
- 12) Pressure display: absoluteness or relative (default: relative)
- 13) Forecast : sun, partly cloudy, cloudy, rain, rain storm (default: partly cloudy)
- 14) Temperature exponent: wind chill, dew point, heat index (default: dew point)
- 15) Light units: lux, fc, w/m2 (default: w/m2)
- 16) Rainfall units: mm, inch (default: mm)
- 17) Rainfall display: rainfall rate/rainfall event/24H/WEEK/MONTH/YEAR (default: RAINFALL RATE)
- 18) Rainfall of year season begin (default: JAN)
- 19) Time alarm: 0:00 → 23:59 (default: 0:00, disable)
- 20) Indoor temperature high alarm: -40.0 → 60.0C (14F → 140F) (default: 20.0C, disable)
- 21) Indoor temperature low alarm: -40.0 → 60.0C (14F → 140F) (default: 0.0C, disable)
- 22) Indoor humidity high alarm: 1% → 99% (default: 65%, disable)
- 23) Indoor humidity low alarm: 1% → 99% (default: 35%, disable)
- 24) Outdoor temperature high alarm: -40.0 → 60.0C (-40F → 140F) (default: 30.0C, disable)
- 25) Outdoor temperature low alarm: -40.0 → 60.0C (-40F → 140F) (default: -10.0C, disable)
- 26) Outdoor humidity high alarm: 1% → 99% (default: 75%, disable)
- 27) Outdoor humidity low alarm: 1% → 99% (default: 45%, disable)
- 28) Wind chill temperature low alarm: -40.0 → 60.0C (-40F → 140F) (default: 0.0C, disable)
- 29) Dew point temperature high alarm: -40.0 → 60.0C (-40F → 140F) (default: 10.0C, disable)
- 30) Dew point temperature low alarm: -40.0 → 60.0C (-40F → 140F) (default: -10.0C, disable)
- 31) Heat index temperature high alarm: -40.0 → 60.0C (-40F → 140F) (default: 27.0C, disable)
- 32) Rainfall alarm: rainfall rate and rainfall 24H: 0-999.9mm (default: 0.0mm, disable)

- 33) Wind speed alarm: 0-50.0m/s (default: 1.8km/h, disable)
- 34) Guest speed alarm: 0-50.0m/s (default: 3.6km/h, disable)
- 35) Light high alarm: 0 to 300000 (default: 200000lux, disable)
- 36) UVI high alarm: 0 to 15 (default: 10, disable)

● **Specifications**

- 1) Indoor temperature measure range: -10 to 60C
- 2) Outdoor temperature measure range: -40 to 60C
- 3) Humidity measuring range: 10% to 99%
- 4) Wind speed measure range: 0 to 50.0m/s
- 5) Wind direction: 0 to 359 degree
- 6) Rainfall range: 0 to 9999.9mm
- 7) Light range: 0 to 300000.0lux
- 8) UVI range: 0 to 15 index (0 to 20000 w/m2)

Troubleshooting Guide

Problem	Solution
<p>Wireless remote (outdoor unit) not reporting in to console.</p> <p>There are dashes (--) on the display console.</p>	<p>Check the thermo-hygrometer-transmitter LED for flashing. You must remove the radiation shield to view the LED.</p> <p>The outside sensor has an LED under the plastic, just above the battery compartment. The LED will flash every 48 seconds.</p> <p>If the LED is not flashing every 48 seconds, Replace the batteries in the outside thermo-hygrometer-transmitter.</p> <p>If the batteries were recently replaced, check the polarity.</p> <p>If the sensor is flashing every 48 seconds, proceed to the next step.</p> <p>There may be a temporary loss of communication due to reception loss related to interference or other location factors,</p> <p>or the batteries may have been changed in the remote and the console has not been reset. The solution may be as simple as powering down and up the console.</p> <ol style="list-style-type: none"> 1. Make sure you have fresh batteries in the display console. 2. With the sensor array and console 10 feet away from each other, remove the batteries

Problem	Solution
	<p>from the display console and wait 10 seconds. Put the batteries back in.</p> <ol style="list-style-type: none"> 3. Do not touch any buttons for several minutes. 4. The remote sensor search icon  will splash on the display. Wait several minutes for this icon to turn off. 5. If the search icon turns off and the outdoor temperature and humidity are still showing dashes (--), the remote sensor is defective. If the sensor properly syncs up, proceed to the next step “How to prevent intermittent wireless communication” <p>How to prevent intermittent wireless communication issues:</p> <ol style="list-style-type: none"> 1. Install a fresh set of batteries in the remote sensor array and console. For cold weather environments, install lithium batteries. 2. The maximum line of sight communication range is 300’ but most users will get 100’ or less due to environmental conditions. Move the sensor and remote closer together. 3. If the sensor assembly is too close (less than 5’), move the sensor assembly away from the display console. 4. Make sure the remote sensors are not transmitting through solid metal like aluminum siding (acts as an RF shield), or earth barrier (down a hill). 5. Move the display console around electrical noise generating devices, such as computers, TVs and other wireless transmitters or receivers. 6. Move the remote sensor to a higher location. Move the remote sensor to a closer location.
Temperature sensor reads too high in the day time.	Make sure the thermo-hygrometer is mounted in a shaded area on the north facing wall.
Indoor and Outdoor Temperature do not agree	<ol style="list-style-type: none"> 1. Allow up to one hour for the sensors to stabilize due to signal filtering. The indoor and outdoor temperature sensors should agree within 4 °F (the sensor accuracy is ± 2 °F). 2. Perform a temperature calibration (reference Section 2.1)
Indoor and Outdoor Humidity do not	<ol style="list-style-type: none"> 1. Allow up to one hour for the sensors to stabilize

Problem	Solution
agree	<p>due to signal filtering. The indoor and outdoor humidity sensors should agree within 10 % (the sensor accuracy is $\pm 5\%$)</p> <ol style="list-style-type: none"> 2. Perform a humidity calibration (reference Section 2.1)
Relative pressure does not agree with official reporting station	<ol style="list-style-type: none"> 1. You may be viewing the relative pressure, not the absolute pressure. 2. Make sure you properly calibrate the barometer to an official local weather station (reference Section 2.1) 3. The barometer is only accurate to ± 0.08 inHg within the following relative pressure range: 27.13 to 32.50 inHg, which corresponds to an altitude of -2,200 to 2,700 feet. At higher altitudes, expect some non-linearity or error.
Time is incorrect	Make sure your time zone and daylight savings time setting is correct.
The forecast icon is not accurate	<p>The weather station console must run for several days to trend barometric pressure.</p> <p>The weather forecast is an estimation or generalization of weather changes in the next 24 to 48 hours, and varies from location to location. The tendency is simply a tool for projecting weather conditions and is never to be relied upon as an accurate method to predict the weather.</p>
Moon phase is not correct	Check your calendar date and make sure it is correct
Display console contrast is weak	Replace console batteries with a fresh set of batteries.

WeatherSmart PC Software User Manual

1.0 General Information

The Weather station is a weather monitoring device that achieves displays and records the weather data from internal and external sensors. Besides the indoor temperature, indoor humidity and air pressure measured by internal sensor, it will receive the outdoor temperature and humidity, wind and rainfall. Light & UVI and Heat index transmitted by outdoor sensor as well.

After installing the “WeatherSmart” program on the CD-ROM in package, It can show you all the weather data from the base station including data from both indoor and outdoor sensors.

For operation, simply use the USB cable supplied and connect the Base Station to the PC. From now on you can start to track current and history weather information at your finger tips.

2.0 System Requirements

To install the “WeatherSmart” software onto your PC, the minimum requirements for PC are as follows:

Operating System: Windows NT4 (Service Pack >= 6a), Windows 2000, Windows XP, Windows Vista, Windows 7, Windows 8, Windows 10, MAC

Base Station and PC must be connected by USB cable

3.0 Installation of the “WeatherSmart” Software

Firstly, the Base Station and the Outdoor Sensors should be connected and checked for correct function (see **Operation Manual for Professional Weather Station** for setting up the Weather Station). After successful checking, install the “WeatherSmart” software as follows:

1. Switch on your PC and insert the CD-ROM into the CD-ROM Drive.
2. Double click “WeatherSmart.exe”
3. Select the installation process language option and click ok
4. click next and select the destination folder(change directory when needed)
5. click next and select the shortcut folder(change directory when needed)
6. click next and select the additional tasks.
7. Click next and setup is now ready to begin installing Weather Smart on your computer.
8. Click install, software will be installed automatically
9. Press Finish to finish the installation process and exit. If you tick “Launch WeatherSmart” the software will start to run.
10. From “Start—All Programs—WeatherSmart” path and double click the “WeatherSmart” icon to start application.

Note: The graphic function needs the software to be installed under the administrator account. If it is installed under limited user accounts, the graphic function of the software might not be working correctly.

3.0 Basic Settings of the “Weather Smart” Software

After the “WeatherSmart.exe” program has been started, the following main window will appear on the PC screen:

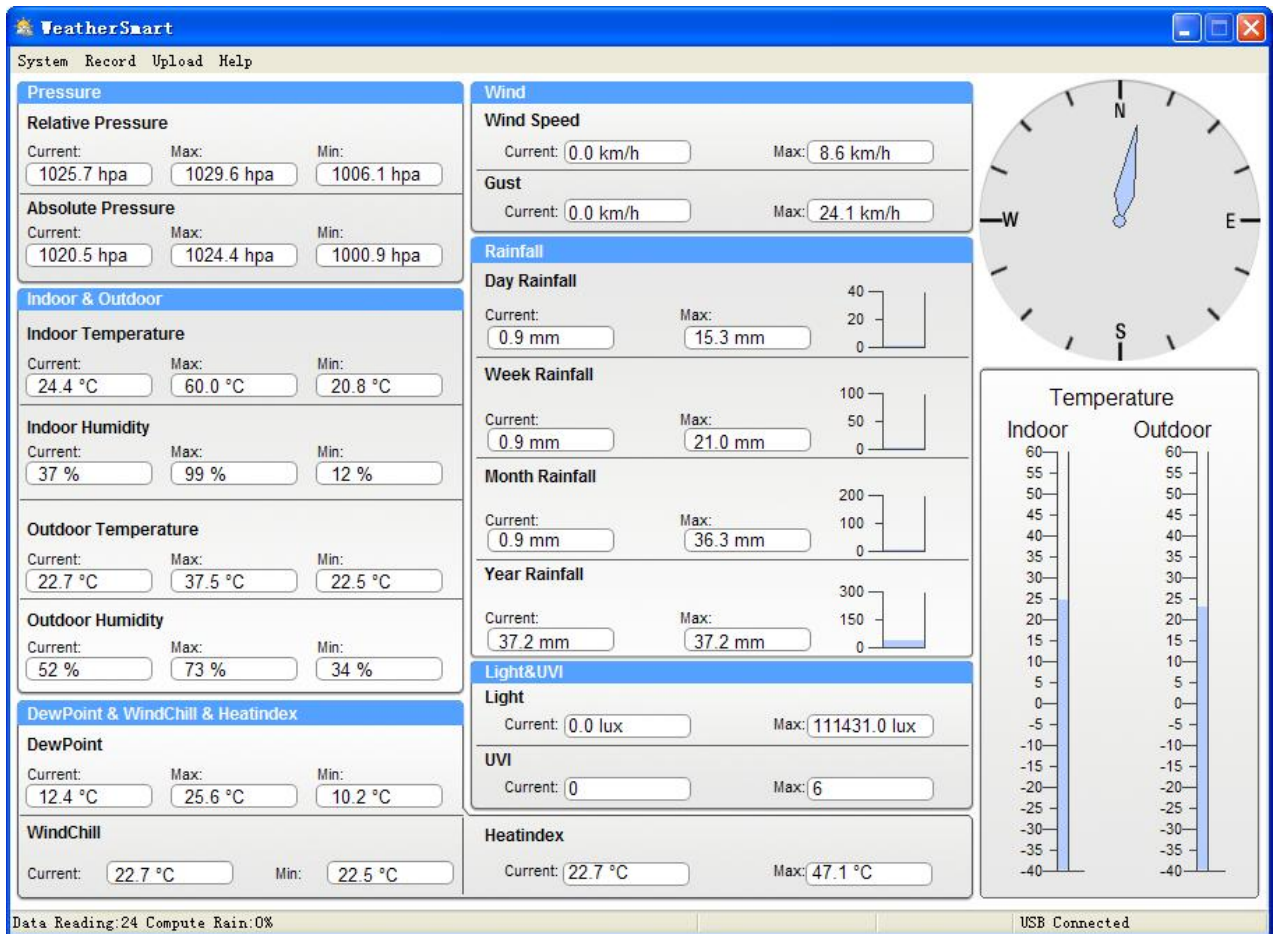

All the settings from the base unit is mirrored into the PC software, so once you have done your setting on the base unit, then you don't need to make any setting changes on the PC software. However you can still easily make any setting changes you wanted from the PC and download the changes into the base station (the setting change will be refreshed when next full minute arrives on the base station).

When the base unit is connected to PC, it shows “USB Connected” at the bottom of screen. If no base station is connected, it shows “USB Unconnected”.

Tool Bar: The tool bar at the top of the screen has 3 options; System, Record and Help.

4.1 System option

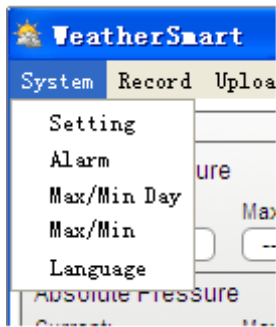

4.1.1 Click System button, enters the Setting menu

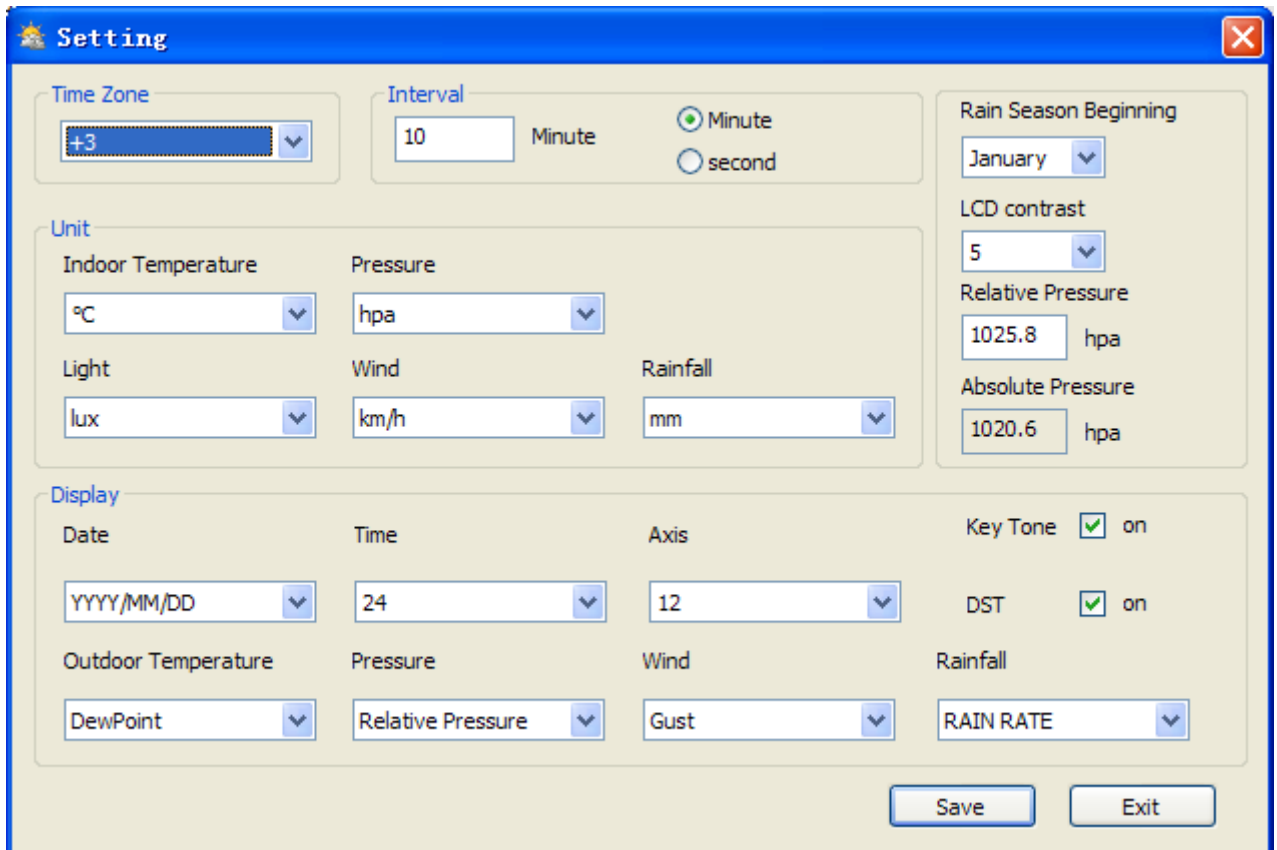

This section is used to set up PC software display, base station units. Once you made your choice, press Save to make the setting effective.

4.1.2 Click Alarm button, enters the Alarm menu

This section is used to set the desired time, high or low alarm value for the base unit, as well as able or disable the corresponding alarm function. Once you made your choice, choose Save to make the setting effective. If you don't want to make any change, just press Cancel and exit without change.

4.1.3 Click Max/Min day button, enters the Max/Min day menu

This section is used to display the recorded the min and max alarm time.

4.1.4 Click Max/Min button, enters the Max/Min menu

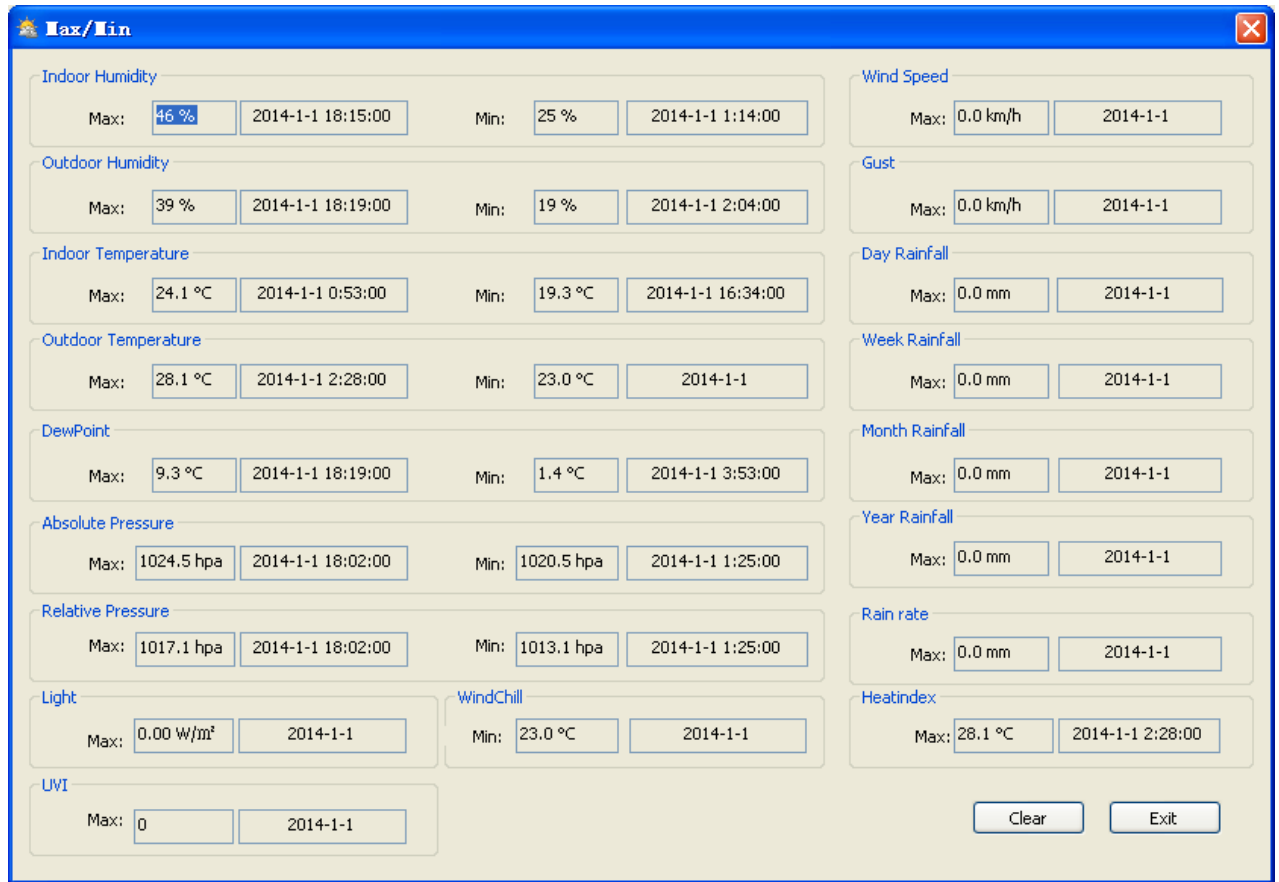

This section is used to display the recorded min and max value recorded with time stamp. Min/Max reset can only be done through key operation on the base station.

4.1.5 Click Language button, enters the Language menu

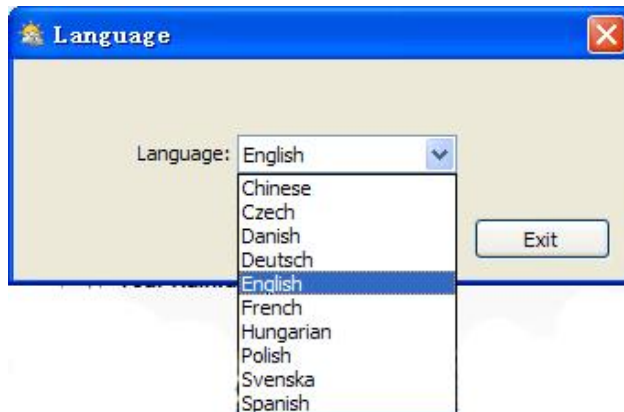

4.2 Record option

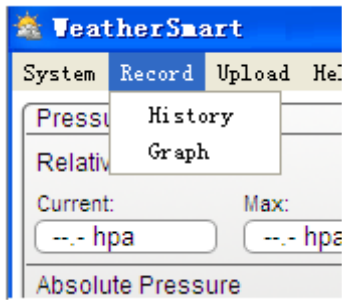

4.2.1 Click History button, enters the History menu

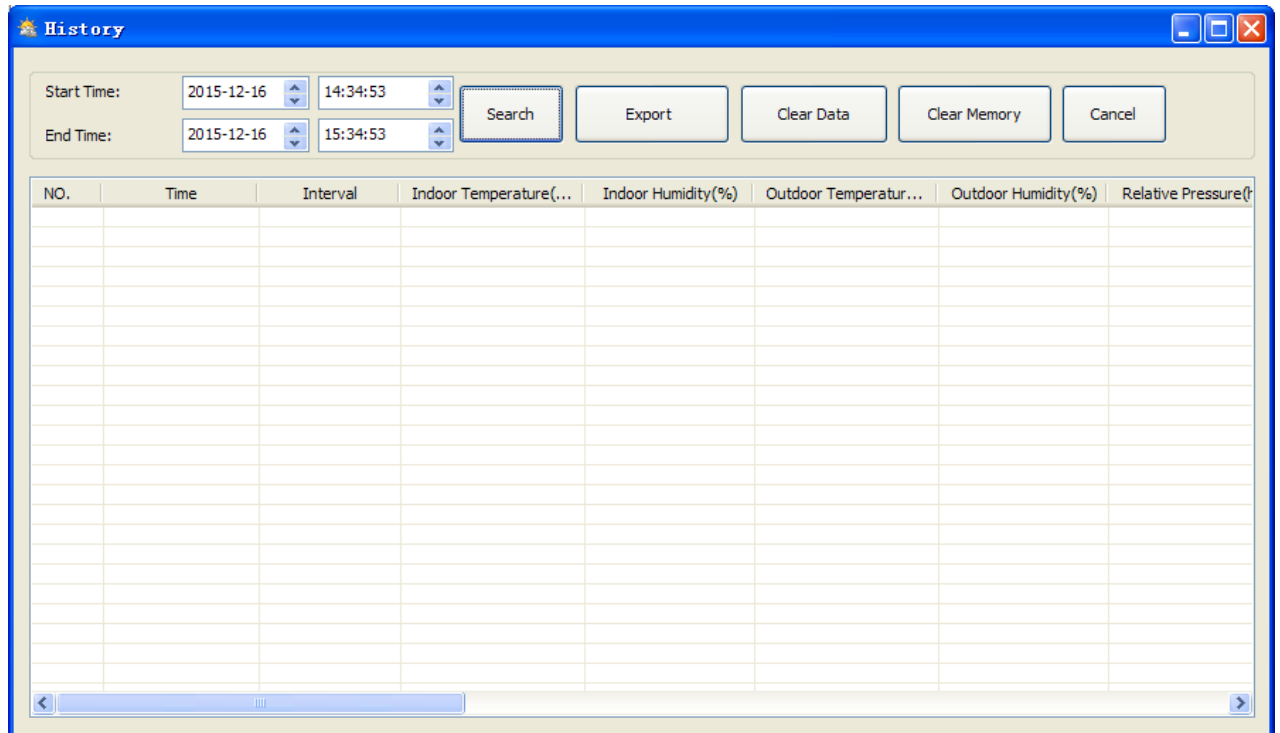

This section is used to display recorded history data in a spread sheet. If you wanted to see all history data in a desired time period, choose the time duration and press Search to reload the history data. With the Export button, you can export the selected history data into excel format and PDF format file for other application purpose. When memory on base station is full, press “Clear Memory” button to refresh the memory space on the base station (remember to upload all data before pressing this button).

If you wanted to start a new weather history record, press “Clear Data” button to clear up the data base, all history weather data will be deleted (if you would like to keep a back up history file before deleting all weather data, you can make a copy of the “WeatherSmart.mdb” file into another folder or just rename the “WeatherSmart.mdb” file, such as “Jan-07.dat”, for future reference.)

4.2.2 Click Graph button, enters the Graph menu

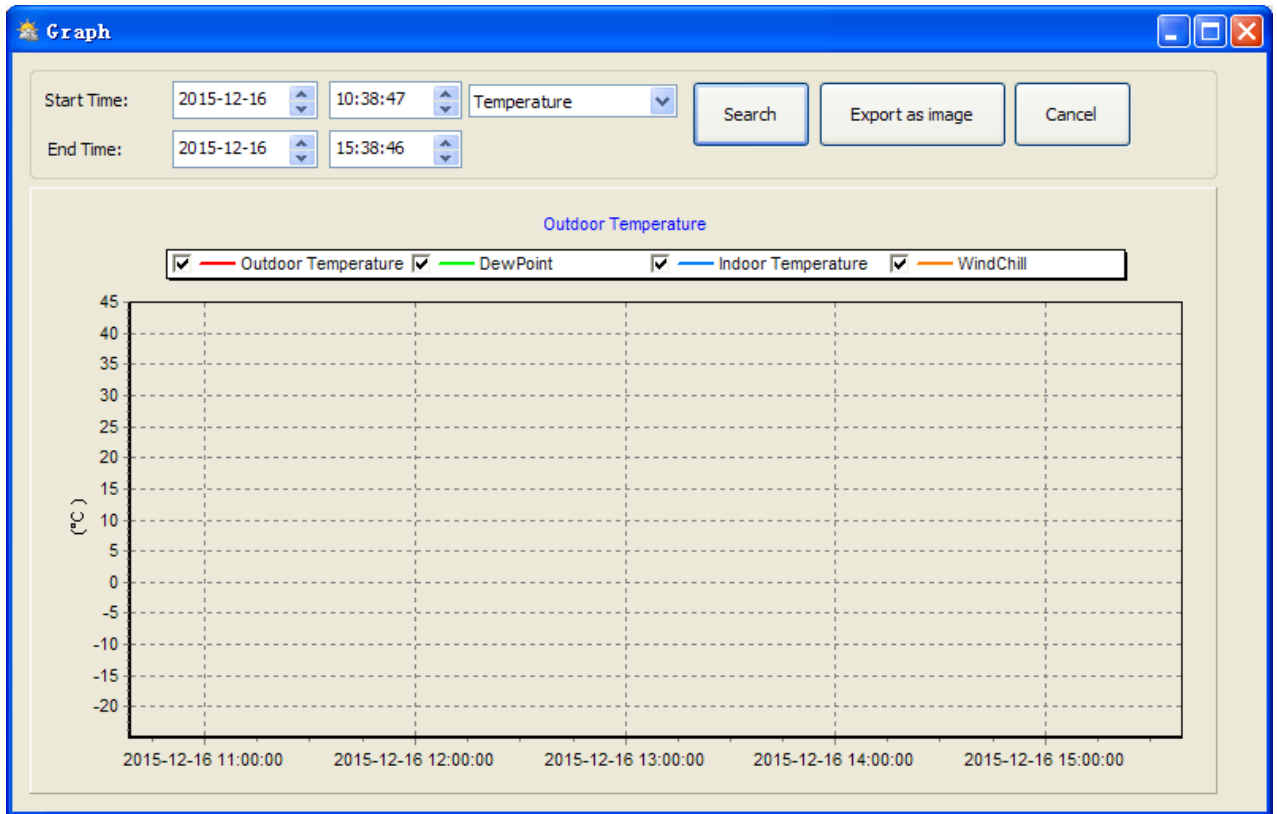

In this section, you can see the history data plotted in graph format for easier observation. If you want to see more details, just use your mouse to select the area you wanted and the display will be automatically updated in more detailed scale:

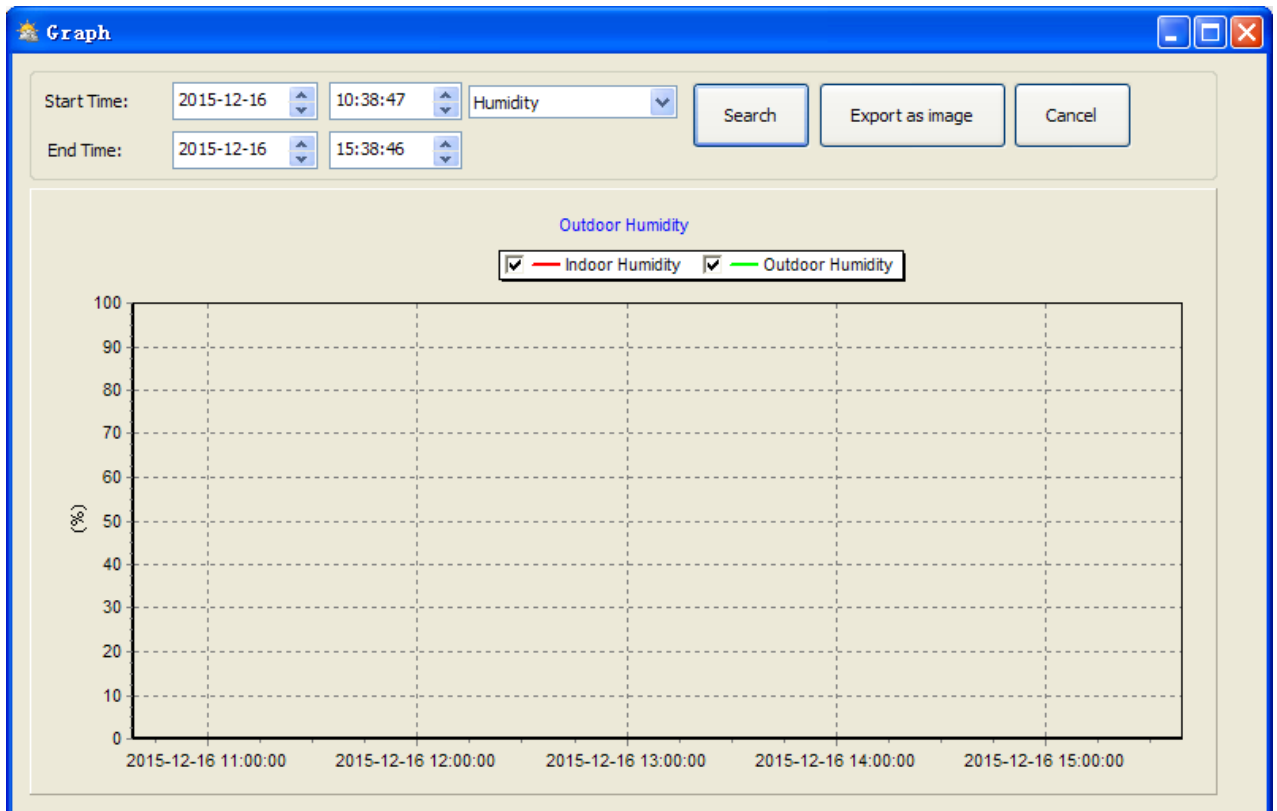

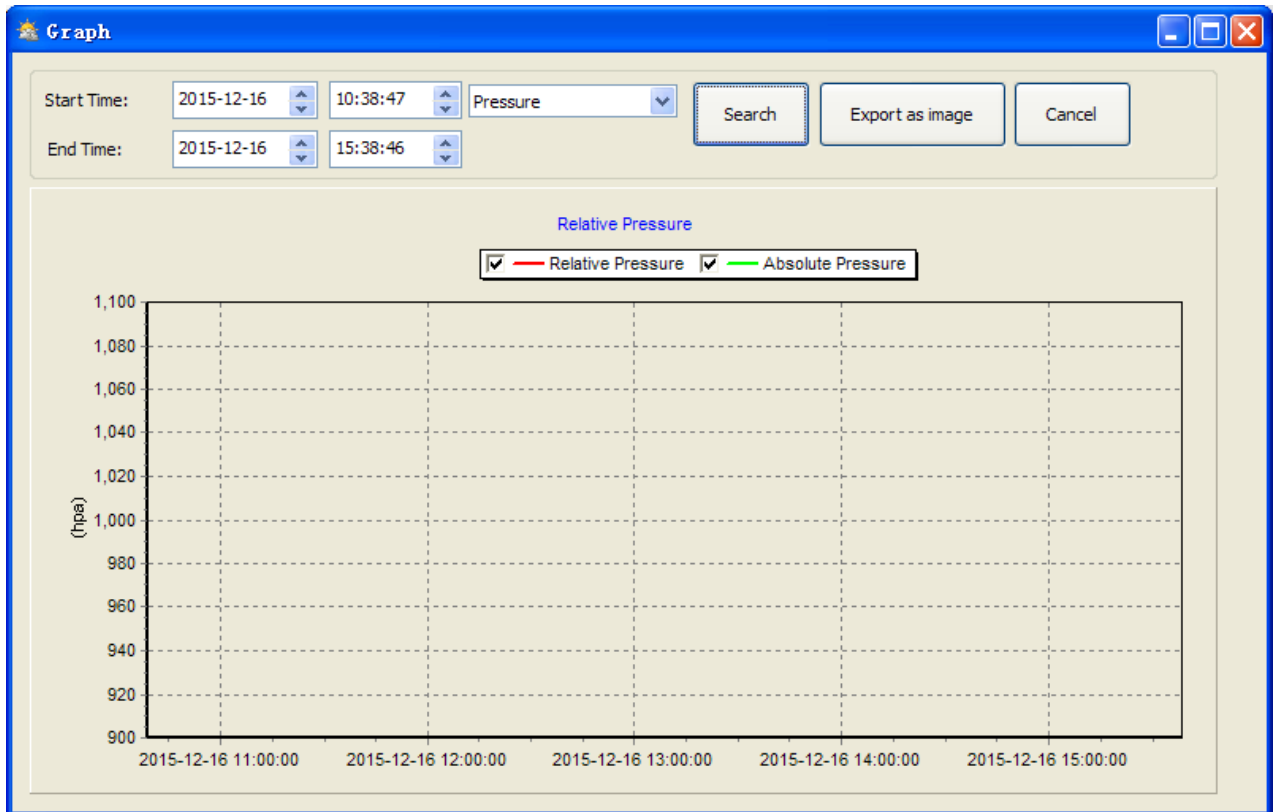

With the Export as image button, you can export the selected graph into .jpeg format file.
 You can change the Y axel by scrolling the mouse up and down roller.

What to do if graph function is not working

This is the most encountered problem with this software. To make the graph function working properly, please check the following step:

- 1, find the folder where the "WeahterSmart.exe" file is located
2. Create a file name "reg_graph.bat" file with wordpad or notepad editor program
3. Type "regsvr32 WeatherSmart.ocx" and save the reg_graph.bat file
4. Double click "reg_graph.bat" file and it should register the graphic driver again. If successful, then the following window will be displayed:



4.3 Upload option

Click Upload button, enters the upload menu

Note: This feature is only available in WeatherSmart Version 1.8 or greater.

4.3.1 Select **Upload|Wunderground.com** from the menu bar.

User can upload data to website. www.wunderground.com or their own website. If user choose www.wunderground.com, he do not need to set the server, server type and port. If user choose custom, he need to set the server, server type and port.

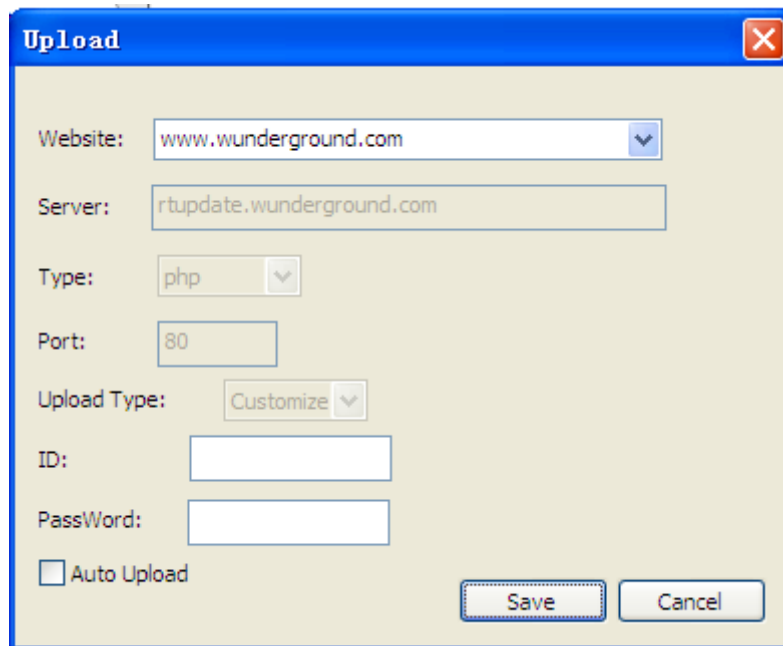

The image shows a standard Windows-style dialog box titled "Upload". It features a blue title bar with a close button (an 'X' in a red square) on the right. The main area is light beige and contains the following elements from top to bottom: a "Website:" label followed by a dropdown menu; a "Server:" label followed by a text box containing "www.wunderground.com" and "(Custom)"; a "Type:" label followed by a dropdown menu set to "php"; a "Port:" label followed by an empty text box; an "Upload Type:" label followed by a dropdown menu set to "Customize"; an "ID:" label followed by an empty text box; a "PassWord:" label followed by an empty text box; and an "Auto Upload" checkbox which is currently unchecked. At the bottom right of the dialog are two buttons: "Save" and "Cancel".

To upload data to Wunderground.com, you must first register on the Wunderground.com website. Registration is free.

Note: How to create a Wunderground.com® account and station ID.

1. Join the Wunderground.com® Community. Visit:

<https://www.wunderground.com/@members/signup.asp>

and sign up with Wunderground.com.

The screenshot shows the 'Join Our Community' page on the Weather Underground website. The page features a navigation bar at the top with the logo and links for 'Maps & Radar', 'Severe Weather', 'News & Blogs', 'Photos & Video', 'Activities', and 'More'. Below the navigation bar, there is a section for 'Recent Cities' with links for Tucson, AZ (75°F Clear), Los Altos, CA, Phoenix, AZ, Phoenix Area, AZ, Santa Rosa, CA, and Manistique, MI. The main heading is 'Join Our Community'. Underneath, there is a 'Become a Member' section with the following fields and options:

- Email:** A text input field.
- Password:** A text input field.
- Confirm Password:** A text input field.
- Handle (What's This?):** A text input field.
- Upgrade my membership for only \$10 per year.
- I agree to the [Terms of Service](#).

A blue button labeled 'Become a Member' is located at the bottom of the form.

2. **Join the Personal Weather Station (PWS) network.** Visit:

<http://www.wunderground.com/personal-weather-station/signup>

or select **More | Register Your PWS** from the menu at the top of the WeatherUndeground.com website:

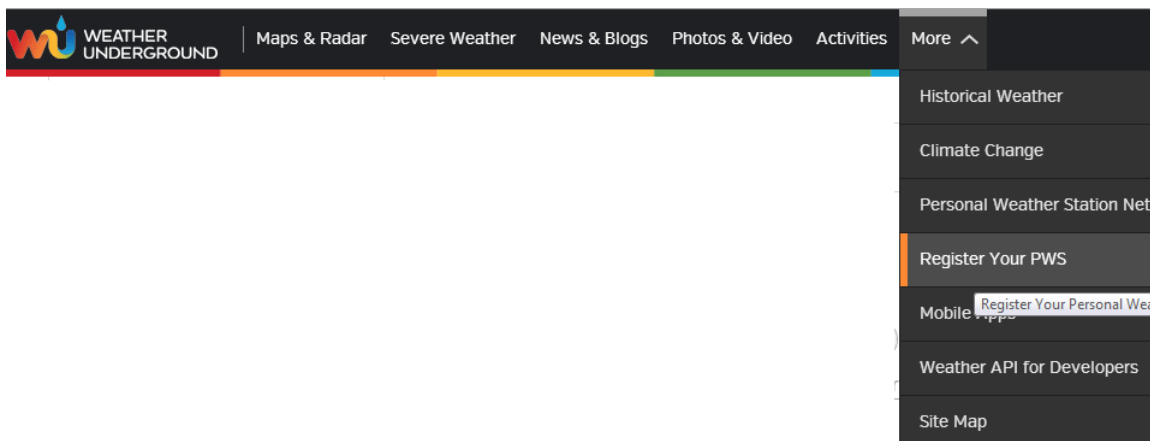

Personal Weather Station Network

Overview | What is a PWS? | Buying Guide | Installation Guide | **Register with WU**

Register a New Personal Weather Station



Enter nearest street address, then move the map to set location for your Personal Weather Station.

enter street address, city, state, country or lat, lon

Latitude: 0.000000
Longitude: 0.000000

Elevation (ft):

Height Above Ground (ft):

Enter your ID obtained and password and select **Auto Upload** checkbox and **Save**.

Please Note: Make sure you enter the ID in all capitals, and the password exactly as you chose it, both fields are case sensitive.

4.3.2 Upload to WeatherBug

Select **Upload | WeatherBug** from the menu bar.

The screenshot shows a dialog box titled "weatherbug" with a blue header and a red close button. It contains the following fields and controls:

- Server: data.backyard2.weatherbug.com
- ID: [Empty text box]
- Password: [Empty text box]
- StationNum: [Empty text box]
- Auto Upload
- Save button
- Cancel button

To upload data to Weatherbug.com, you must first register on the Weatherbug.com website. Registration is free.

1. Visit <http://backyard.weatherbug.com/> and select Join if you do not have an account.
2. Once registered with Weatherbug.com you will need to sign up your station. To get started visit:

<http://backyard.weatherbug.com/group/backyardstations/page/backyardstations>

Enter your ID, password and station number and select **Auto Upload** checkbox and **Save**.

4.3.3 Upload to WeatherCloud

Select **Upload | WeatherCloud** from the menu bar.

Weathercloud.net

The screenshot shows a dialog box titled "weathercloud" with a blue header and a red close button. It contains the following fields and controls:

- Server: api.weathercloud.net
- ID: [Empty text box]
- key: [Empty text box]
- Auto Upload
- Save button
- Cancel button

4.4 Help option

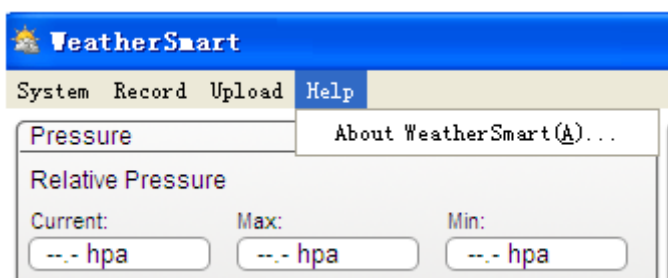

Click About “WeatherSmart” button, enters the About menu

5.0 “WeatherSmart” Software on MAC OS

Insert the CD-ROM into the CD-ROM Drive and double click the WeatherSmart software icon, the main interface as below will be opened:

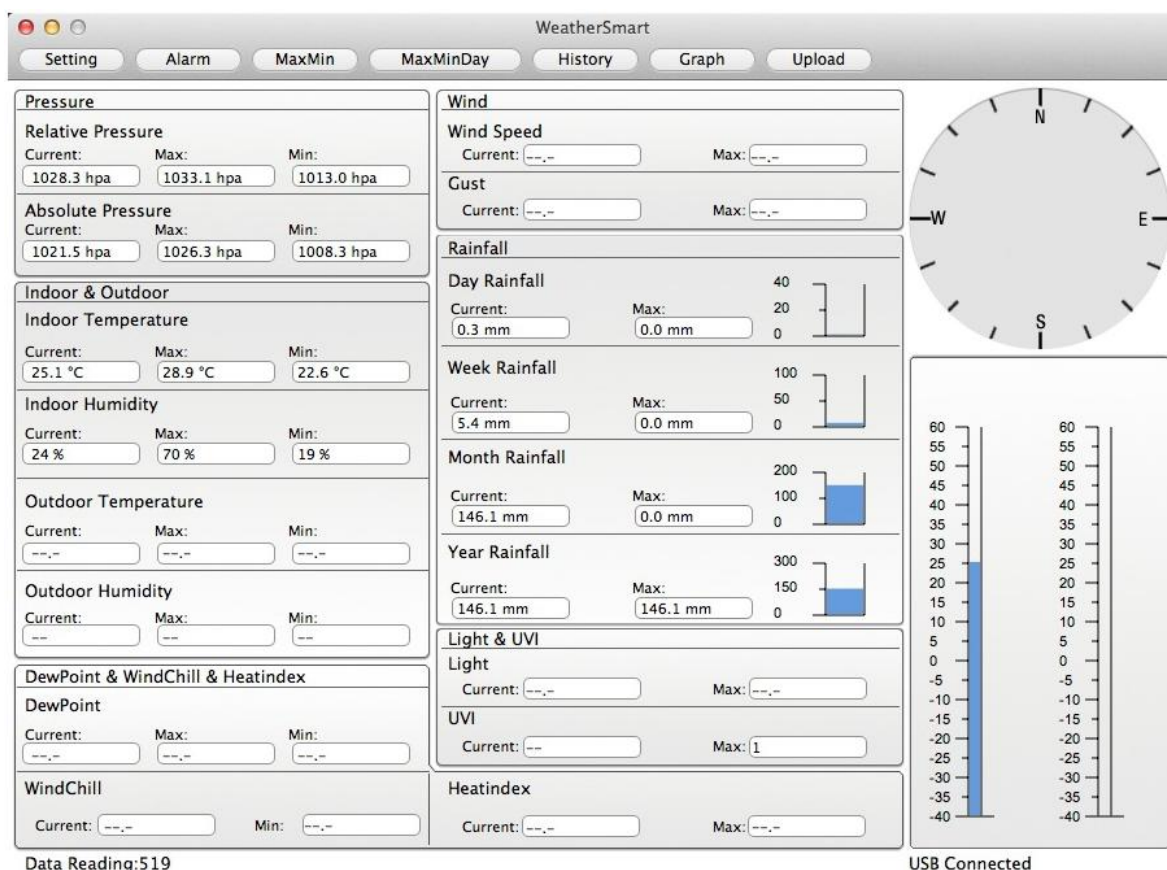

The functions of MAC OS are the same to the windows version. Once the device is connected to MAC PC by USB cable, settings, alarms of all weather parameter can be done here. Max/Min record, all history record can be viewed. History records can be exported as excel or PDF file as well.

5.1 Setting option:

Please refer to 4.1.1

Setting

Interval: 16s Second Time Zone: -5 Rain Season Begin: 2 LCD contrast: 5

Unit
Temperature: °C Pressure: hpa
Light: lux Wind: m/s Rainfall: mm

Calibration
Relative Pressure: 1028.3 hpa
Absolute Pressure: 1021.5 hpa

Display
Date: YYYY/M... Time: 12 Axis: 12 Outdoor Temperature: WindChill
Pressure: Relative... Wind: Gust Rainfall: DAY

Save Cancel

5.2 Alarm option:

Please refer to 4.1.2

Alarm

Indoor Humidity: High 65 % Low 35 %
Outdoor Humidity: 75 % 45 %
Indoor Temperature: 30.0 °C 10.0 °C
Outdoor Temperature: 30.0 °C 10.0 °C
DewPoint: 30.0 °C -10.0 °C
Relative Pressure: 1040.0 hpa 960.0 hpa
Absolute Pressure: 1040.0 hpa 960.0 hpa

Alarm: Select 3:04 PM
Wind Speed: 5.0 m/s
Gust: 5.0 m/s
Day Rainfall: 9.0 mm
Rain rate: 9.0 mm
WindChill: 20.0 °C
Light: 0.0 lux
UVI: 9
Heatindex: 20.0 °C

Save Cancel

5.3 Max/Min option

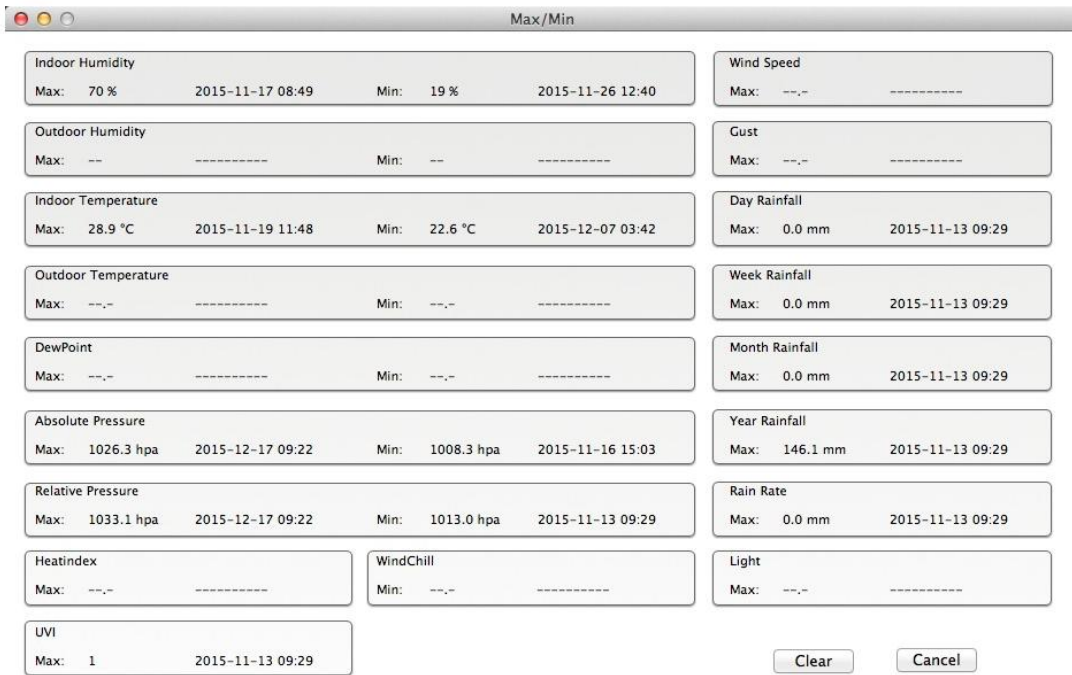

5.4 History option:

Please refer to 4.2.1

The 'History' window shows a log of weather data from 17/12/2015 4:49 PM to 5:49 PM. The data is organized into columns for various parameters:

NO.	Time	Interval	InTemp	InHumi	OutTemp	OutHumi	RelPressure	AbsPres...	DewPoint	WindChill	Wind	Gust	WindD
193	2015-12-17 17:41:14	10 s	25.3	23	--	--	1028.3	1021.5	--	--	--	--	--
194	2015-12-17 17:41:30	16 s	25.3	23	--	--	1028.3	1021.5	--	--	--	--	--
195	2015-12-17 17:41:46	16 s	25.3	23	--	--	1028.3	1021.5	--	--	--	--	--
196	2015-12-17 17:42:02	16 s	25.3	23	--	--	1028.4	1021.6	--	--	--	--	--
197	2015-12-17 17:42:18	16 s	25.3	23	--	--	1028.4	1021.6	--	--	--	--	--
198	2015-12-17 17:42:34	16 s	25.3	23	--	--	1028.4	1021.6	--	--	--	--	--
199	2015-12-17 17:42:50	16 s	25.3	23	--	--	1028.4	1021.6	--	--	--	--	--
200	2015-12-17 17:43:06	16 s	25.3	23	--	--	1028.4	1021.6	--	--	--	--	--
201	2015-12-17 17:43:22	16 s	25.3	23	--	--	1028.4	1021.6	--	--	--	--	--
202	2015-12-17 17:43:38	16 s	25.3	23	--	--	1028.4	1021.6	--	--	--	--	--
203	2015-12-17 17:43:54	16 s	25.3	23	--	--	1028.4	1021.6	--	--	--	--	--
204	2015-12-17 17:44:10	16 s	25.3	23	--	--	1028.4	1021.6	--	--	--	--	--
205	2015-12-17 17:44:26	16 s	25.3	23	--	--	1028.4	1021.6	--	--	--	--	--
206	2015-12-17 17:44:42	16 s	25.3	23	--	--	1028.4	1021.6	--	--	--	--	--
207	2015-12-17 17:44:58	16 s	25.4	23	--	--	1028.4	1021.6	--	--	--	--	--
208	2015-12-17 17:45:14	16 s	25.4	23	--	--	1028.5	1021.7	--	--	--	--	--
209	2015-12-17 17:45:30	16 s	25.4	23	--	--	1028.5	1021.7	--	--	--	--	--
210	2015-12-17 17:45:46	16 s	25.4	23	--	--	1028.5	1021.7	--	--	--	--	--
211	2015-12-17 17:46:02	16 s	25.4	23	--	--	1028.4	1021.6	--	--	--	--	--
212	2015-12-17 17:46:18	16 s	25.4	23	--	--	1028.4	1021.6	--	--	--	--	--
213	2015-12-17 17:46:34	16 s	25.4	23	--	--	1028.4	1021.6	--	--	--	--	--
214	2015-12-17 17:46:50	16 s	25.4	23	--	--	1028.4	1021.6	--	--	--	--	--
215	2015-12-17 17:47:06	16 s	25.4	23	--	--	1028.4	1021.6	--	--	--	--	--
216	2015-12-17 17:47:22	16 s	25.4	23	--	--	1028.4	1021.6	--	--	--	--	--
217	2015-12-17 17:47:38	16 s	25.4	23	--	--	1028.4	1021.6	--	--	--	--	--
218	2015-12-17 17:47:54	16 s	25.4	23	--	--	1028.4	1021.6	--	--	--	--	--
219	2015-12-17 17:48:10	16 s	25.4	23	--	--	1028.4	1021.6	--	--	--	--	--
220	2015-12-17 17:48:26	16 s	25.4	23	--	--	1028.4	1021.6	--	--	--	--	--
221	2015-12-17 17:48:42	16 s	25.4	23	--	--	1028.4	1021.6	--	--	--	--	--

Buttons: Select, Export, Clean History, Clean Memory, Cancel

5.5 Graph

Please refer to 4.2.2

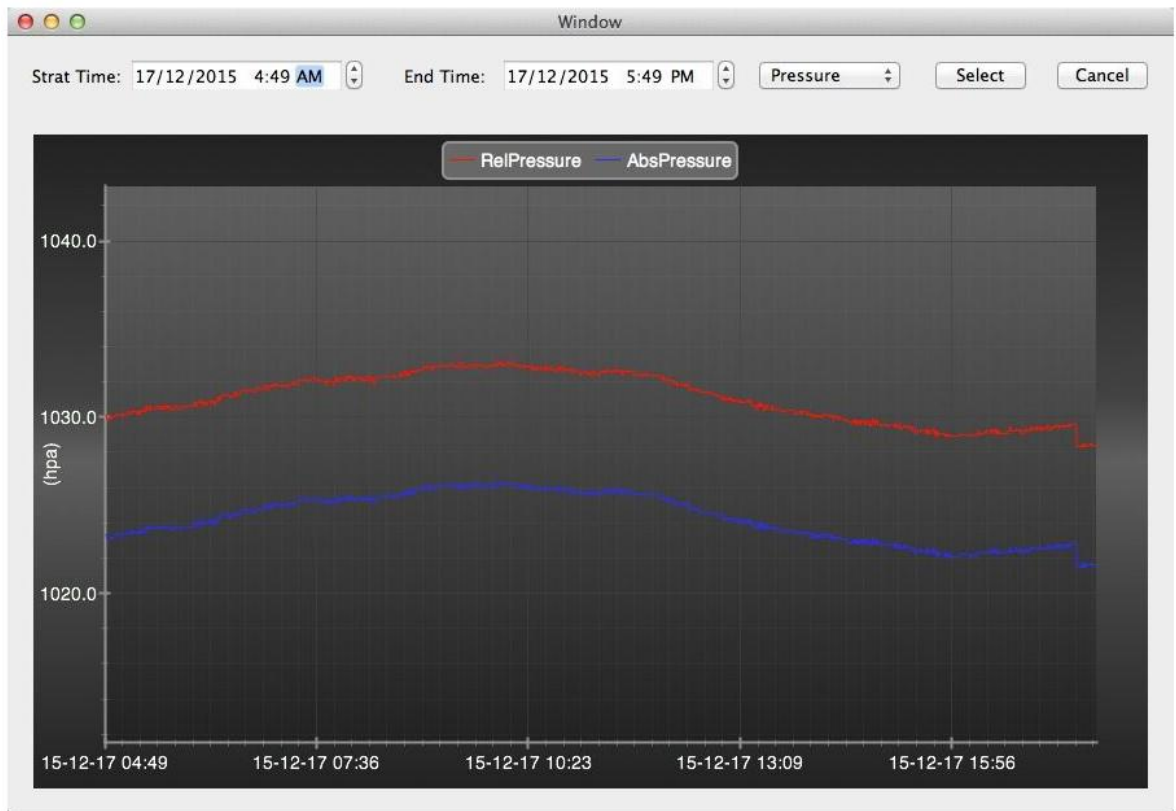

5.6 Upload option:

Please refer to 4.3

5.7 Check software version

Click About WeatherSmart button, enters the About menu to check version information,

Special Notes about time synchronization between PC and sub-station:

The PC software obtained its own time scale through the time interval marker from the base station history data, and the PC software automatically synchronizes the weather data with a time stamp calculated. Thus the history data file can have different time when the PC time and base station time is not same. In order to make the time scale correct, remember to set the PC time and base station time same, and further to this, no weather data is allowed to be missed or over-written. If history weather memory on the base station is cleared by manual setting, then the history weather data since last uploading is lost permanently.

Before memory is used up(memory icon on LCD display showing 100% full), remember to upload weather history data to PC periodically.

If there is a reset happened for the rain fall on the base station, then there will be rain fall value discrepancy between PC and base station.

FCC Statement

This equipment has been tested and found to comply with the limits for a Class B digital device, pursuant to part 15 of the FCC Rules. These limits are designed to provide reasonable protection against harmful interference in a residential installation. This equipment generates uses and can radiate radio frequency energy and, if not installed and used in accordance with the instructions, may cause harmful interference to radio communications. However, there is no guarantee that interference will not occur in a particular installation. If this equipment does cause harmful interference to radio or television reception, which can be determined by turning the equipment off and on, the user is encouraged to try to correct the interference by one or more of the following measures:

- Reorient or relocate the receiving antenna.
- Increase the separation between the equipment and receiver.
- Connect the equipment into an outlet on a circuit different from that to which the receiver is connected.
- Consult the dealer or an experienced radio/TV technician for help.

FCC Statement

This device complies with Part 15 of the FCC Rules. Operation is subject to the following two conditions: (1) this device may not cause harmful interference, and (2) this device must accept any interference received, including interference that may cause undesired operation.

Caution!

Any changes or modifications not expressly approved by the party responsible for compliance could void the user's authority to operate the equipment.

Legal Notes

- We reserve the right to delete or change any image whether or not purposely uploaded onto the server by a user of the touch screen weather station and the WeatherSmart software products.
- The WeatherSmart software products are protected by copyright laws and international copyright treaties as well as other intellectual property laws and treaties.
- You may not copy the printed materials accompanying the products.