

HotPort™

Hardware Installation Guide
HotPort 3203-Public Safety
Outdoor Wireless Mesh Node



Hardware Installation Guide

HotPort 3203 - Public Safety Outdoor Wireless Mesh Node

October 2005

Manual Revision 1.3

Copyright Notice

©2003-2005 Firetide, Inc. All rights reserved.

Trademarks

Firetide, the Firetide logo, Instant Mesh Networks, HotPort are trademarks of Firetide, Inc. All other trademarks are the property of their respective owners.

HotPort Limited End User Product Warranty

Pursuant to all provisions described herein, Firetide products are warranted for one (1) year from the date of purchase against defects in the build materials and workmanship. Firetide also warrants that the Software will materially conform to the documentation supplied by Firetide with the Software. In the event that the Software fails to materially conform to the documentation and an authorized Firetide reseller is notified in writing of such failure within the warranty period, Firetide or its reseller shall use commercially reasonable efforts to promptly correct the nonconformity. Firetide does not warrant that the use of the Software will be uninterrupted or error free. Firetide does not warrant that the Products will meet any requirements or specifications of any End User Customer. This warranty applies to the entire Firetide product, including antennas and the AC power adapter.

The above warranties are void if the alleged defect cannot be verified by Firetide or if, as determined by Firetide, the product failure was due to tampering, abuse, misuse, accident, shipping, handling, or storage; or if the product has been installed, used, or maintained in a manner not described in the product user manual, if the product has been altered in any way, or if product serialization has been altered. Any attempt to disassemble or repair the product by anyone other than Firetide immediately voids this warranty.

This warranty applies only to the original End User purchaser of the product and may not be transferred to any other individual or entity.

THE FOREGOING ARE THE EXCLUSIVE WARRANTIES APPLICABLE TO THE PRODUCT INCLUDING THE SOFTWARE, AND THE EXCLUSIVE REMEDY FOR DEFECTS IN THE PRODUCT. FIRETIDE DISCLAIMS ALL OTHER WARRANTIES, WHETHER EXPRESS, IMPLIED, STATUTORY OR OTHERWISE, INCLUDING BUT NOT LIMITED TO IMPLIED WARRANTIES OF MERCHANTABILITY, NON-INFRINGEMENT OR FITNESS FOR A PARTICULAR PURPOSE. SOME LAWS DO NOT ALLOW THE EXCLUSION OF IMPLIED WARRANTIES SO TO THAT EXTENT THIS LIMITATION MAY NOT APPLY TO YOU.

In no event will Firetide be liable for any special, incident-

tal, consequential, punitive or indirect damages whatsoever (including, without limitation, damages for loss of profits, business interruption, loss of information, or other pecuniary loss) arising out of the use or inability to use the product or the performance, interruption or failure of the product, irrespective of the cause of action, even if Firetide has been advised of the possibility of such damages. Firetide's cumulative liability for all claims arising out of or in connection with this warranty will not exceed the amount paid by the original End User purchaser to purchase the product. The amounts payable for the product are based in part on these limitations and these limitations shall apply notwithstanding the failure of essential purpose of any remedy. Some jurisdictions do not allow the exclusion or limitation of incidental or consequential damages, so to that extent the above limitations or exclusions may not apply to you.

By using the product the original End User purchaser agrees to and is bound by these terms and conditions.

In the event that a product fails to meet this warranty and Firetide's authorized reseller is notified in writing of such failure within the warranty period, Firetide shall, at its own discretion, either repair the product or replace it with the same or a functionally-equivalent product free of charge. Replacement products may contain refurbished materials in whole or in part. Firetide will honor this warranty provided the product is returned through an authorized Firetide reseller or dealer with shipping charges prepaid, along with a proof of purchase describing the original purchase date and product serial numbers if applicable. The authorized reseller must acquire a Return Materials Authorization (RMA) number from Firetide prior to returning any product. Firetide does not accept shipments of defective products without shipping charges prepaid.

Safety Instructions

The HotPort 3203 outdoor wireless mesh node must be installed by a qualified professional such as a licensed electrician. Failure to install this equipment properly may result in equipment damage and personal injury or death.

Explanation of Graphic Symbols



This symbol is intended to alert the user to the presence of non-insulated dangerous voltage that may be of sufficient magnitude to constitute a risk of lethal electric shock to persons.



This symbol is intended to alert the user to the presence of important operating, maintaining and servicing instructions in the literature accompanying the HotPort 3203. Failing to comply with this instruction may result in electrical shock.



This symbol is intended to alert the user to the presence of important operating, maintaining and servicing instructions in the literature accompanying the HotPort 3203. Failing to comply with this instruction may result in a hazard.



Caution! Risk of electric shock!



POWER LINES CAN BE LETHAL

Do not install the HotPort 3203 outdoor mesh node where possible contact with power lines can be made. Antennas, poles, towers, guy wires, or cables may lean or fall and contact these lines. People may be injured or killed if they are touching or holding any part of equipment when it contacts electric lines. Make sure there is NO possibility that equipment or personnel can come in contact directly or indirectly with power lines.

ASSUME ALL OVERHEAD LINES ARE POWER LINES

The horizontal distance from a tower, pole or antenna to the nearest power line should be at least twice the total length of the pole/antenna combination. This will ensure that the pole will not contact power if it falls either during or after installation.

SURVEYING THE SITE

Look over the entire site before beginning any installation and anticipate possible hazards. Never assume anything without checking it out for yourself! Don't take shortcuts!

TO AVOID FALLING, USE SAFE PROCEDURES WHEN WORKING AT HEIGHTS ABOVE GROUND

- Select equipment locations that will allow safe and simple installation.
- Don't work alone. A friend or co-worker can save your life if an accident happens.
- Don't attempt repair work when you are tired. Not only will you be more careless, but your primary diagnostic tool - deductive reasoning - will not be operating at full capacity.
- Use approved non-conducting ladders, shoes, and other safety equipment. Make sure all equipment is in good repair.
- If a tower or pole begins falling, don't attempt to catch it. Stand back and let it fall.

- If anything such as a wire or pole does come in contact with a power line, DON'T TOUCH IT OR ATTEMPT TO MOVE IT. Instead, save your life by calling the power company.
- Don't attempt to erect antennas or towers on windy days.
- MAKE SURE ALL TOWERS AND POLES ARE SECURELY GROUND-ED, AND ELECTRICAL CABLES CONNECTED TO ANTENNAS HAVE LIGHTNING ARRESTORS. This will help prevent fire damage or human injury in case of lightning, static build-up, or short circuit within equipment connected to the antenna. The HotPort 3203 has built-in lightning protection. Be sure that any other equipment connected to the HotPort 3203 also has the same level of protection.
- The base of the antenna pole or tower must be connected directly to the building protective ground or to one or more approved grounding rods, using 10 AWG ground wire and corrosion-resistant connectors.
- Refer to the National Electrical Code for grounding details.

IF AN ACCIDENT SHOULD OCCUR WITH THE POWER LINES

- DON'T TOUCH THAT PERSON, OR YOU MAY BE ELECTROCUTED.
- Use a non-conductive dry board, stick, or rope to push or drag them so they no longer are in contact with electrical power.
- Once they are no longer contacting electrical power, administer CPR if you are certified.
- Immediately have someone call for medical help.



Do not open the cover



- Dangerous voltages inside.
- No serviceable parts inside.
- Refer to qualified service personnel.
- Unit must be disconnected from power prior to servicing.
- Unit has tamper-evident labeling that indicates when the cover has been removed.

Contents

Firetide HotPort 3203 Outdoor Wireless Mesh Node	2
Example Networks/Applications	3
Planning Your Network	3
Power Options	4
<i>Power Supply</i>	4
<i>Power over Ethernet (PoE)</i>	4
HotPort 3203 Installation	5
Unpacking	5
<i>Mesh Node</i>	5
<i>Antenna Assembly</i>	5
<i>Ethernet Transition Cable/RJ-45 Male Connector Kit</i>	5
<i>Power Supply</i>	5
<i>Documentation</i>	5
<i>Compact Disk (CD)</i>	5
Required Tools and Supplies	5
Building a Firetide Mesh Network	6
Planning Your Network	6
<i>Understanding HotPort Antenna Patterns</i>	6
Staging Considerations	7
Preparing the Site for Mounting	8
<i>Safety Considerations</i>	8
<i>Weatherproofing</i>	8
<i>Preparing Earth Ground</i>	8
Mounting the Antenna	9
<i>Mounting Guidelines</i>	9
Mounting the Enclosure	12
<i>Mounting Guidelines</i>	12
<i>Wall Mounting</i>	12
Pole Mounting	13
Using Mounting Straps	14
Installing the Sunshield	15
Connecting the Power	16
<i>Connecting AC Power</i>	16
<i>Connecting Power over Ethernet</i>	17
<i>Connecting an External Battery Backup System or Solar Power</i>	18
Connecting Peripherals	19
<i>Providing Power over Ethernet to Peripherals</i>	19
Starting Up and Connecting to the Mesh	20
<i>Startup Sequence</i>	20
<i>Connecting to the Mesh</i>	20
Appendix A Contacting Firetide	21
Appendix B Connectors	22
HotPort 3203 Ethernet Transition Cable Pin Descriptions	22
<i>Circular, Watertight IP66-Rated Connector and Port Pin Descriptions</i>	22
<i>RJ-45 Connector Pin Descriptions</i>	22
Power Transition Cable Pin Descriptions	23
Appendix C Specifications	24

Firetide HotPort 3203 Outdoor Wireless Mesh Node

HotPort™ 3200 series outdoor mesh nodes have weatherproof enclosures and connect wirelessly to indoor and outdoor HotPort nodes to form a high-performance wireless mesh network. Outdoor nodes feature a built-in dual-port 10/100 Ethernet switch and dual-spectrum radios. A choice of antennas is available. The nodes can operate at 2.4 GHz for maximum capacity and range, or at 5 GHz for maximum capacity and minimal interference from 2.4 GHz devices.

Units designed for operation on the 4.9 GHz Public Safety band are also available. HotPort 3203 nodes designed for public safety use are identified as such on the unit label. These units may only be used by FCC-licensed public safety agencies.

Both Ethernet ports are weatherproof and support 802.3af Power over Ethernet (PoE). A removable sunshield and a mounting bracket are provided with each unit. Options include an integrated backup battery.

The HotPort 3203 provides Ethernet connectivity for outdoor devices without the need for a wired backhaul. This enables fast deployment of outdoor networking equipment, such as weatherized access points and surveillance cameras, virtually anywhere, without costly cabling.

Firetide™ mesh networks provide a reliable, flexible, and scalable alternative to cabling and leased lines. Because they form automatically without wires and do not require line-of-sight, Firetide mesh networks can be installed without modifications to

buildings or landscaping. Outdoor network installation costs are dramatically lower because time-consuming trenching and cable pulling between buildings is not required. Provisioning is also easy and fast because no special drivers, setup, and interfaces are required for the equipment you connect to a Firetide instant mesh network.

While operating at 5 GHz, the HotPort 3203's radio can cover distances up to 2600 ft (800 m). This long reach between HotPort mesh nodes enables you to extend your network to areas that are otherwise too distant, expensive, difficult, or environmentally sensitive to wire with LAN cable.

The two weatherproof 10/100 Ethernet connectors provide for connecting Ethernet devices, such as access points, surveillance cameras, and sensors. The package includes an indoor-rated power supply, with a country- or region-specific power cord and a 10 m (33 ft) power transition cable, which can supply power from an indoor or fully enclosed AC power source. The HotPort 3203 mesh node can supply Power over Ethernet to auxiliary Ethernet devices up to a maximum of 48 VDC. Two omni-directional antennas attach to the bottom of the HotPort 3203 enclosure via a connector and cable.

Because all mesh nodes are interconnected, a single gateway can provide Internet access to the entire mesh network. HotPort 3203 outdoor mesh nodes are fully compatible with HotPort 3100 series nodes, enabling the mesh to extend to indoor applications.



Example Networks/Applications

Here are some examples of how you can use HotPort wireless mesh networks in your workplace:

- Provide Ethernet service over a wireless backhaul to buildings where wired solutions via Category 5 cabling or fiber is impractical or too expensive.
- Connect access points to networks from locations where it is impractical to run cable to the access points.
- Connect security cameras to monitor remote locations.

Planning Your Network

Before implementing a wireless mesh network, perform the following preliminary steps:

- To ensure a safe installation of the HotPort 3203, follow the appropriate electrical and building codes (such the National Electrical Code (NEC)), country codes, or local building codes.
- Don't install near overhead power lines! It's dangerous, and nearby wires will reduce overall coverage and performance.
- When identifying a location for mounting the antenna, keep in mind that you should not mount the antenna within 3 ft (0.9 m) of another antenna. If you do, interference may occur.
- HotPort nodes do not require line-of-sight between them, but you can increase the working distance of your wireless mesh by avoiding obstacles between nodes. For best performance, ensure that each HotPort node has a clear line of sight to at least two other HotPort nodes.
- Look for physical obstructions, such as building or trees, and avoid installing the antenna where there is obstruction between antennas. Installations in winter months around trees may not pose a problem, but once the leaves appear they may pose an obstruction.
- Keep in mind that buildings may cause radio signal obstruction, depending on the material used in construction.
- Avoid areas where the RF lines of sight are blocked by heavy vehicle and foot traffic. Do not install near rain gutters and downspouts or areas subject to flooding.
- Consider ways to protect your HotPort node from theft and vandalism. Try to place HotPort nodes in areas where access by unauthorized individuals is restricted (such as on a rooftop, a tall pole, and so on). After you mount the HotPort, you can secure it by placing a lock on the mounting bracket.
- Survey the site for grounding options. It is crucial to have a good earth ground for the HotPort 3203 and the antenna.
- Make sure that the horizontal distance from a tower, pole, or antenna to the nearest power line is at least twice the total length of the pole/antenna combination. This will prevent the tower, pole, or antenna from contacting power if it falls either during or after installation.
- Make sure that you can install the HotPort node close enough to an AC power outlet so you can connect the HotPort node's AC power supply to the outlet. If you plan to power a HotPort node via an Ethernet connection (using the Power over Ethernet option), make sure you have an Ethernet cable long enough to connect the HotPort node to the Power Sourcing Equipment (see the "Connecting the Power" section for information).
- Make sure the location where you install the HotPort node is accessible to the devices you intend to connect to the HotPort node (access points, cameras, and so on).

Power Options

There are various options for supplying power to the HotPort 3203.

Power Supply

The power supply can provide power to the HotPort 3203 enclosure from an AC outlet. The power supply is rated for 90-240 VAC. Optionally, when the HotPort 3203 receives power from the power supply, you can provide power to two peripheral devices connected to the HotPort 3203's Ethernet ports.

Power over Ethernet (PoE)

The HotPort 3203 outdoor mesh node has two weatherproof Ethernet ports to provide Ethernet connectivity to outdoor peripheral Ethernet devices, such as access points or surveillance cameras. Use of these ports is optional.

Both ports 1 and 2 on a HotPort 3203 can provide Power over Ethernet (PoE) functionality to Powered Devices (PD) connected to these ports. A Powered Device can receive data and the power to process the data from the HotPort 3203, which functions as Power Sourcing Equipment (PSE) in this configuration. To receive power from a HotPort 3203, the device must support the IEEE 802.3af standard, which defines PoE functionality, and the HotPort 3203 must be powered directly via its DC power port.

Alternatively, you can power the HotPort 3203 by connecting Power Sourcing Equipment to either Ethernet port 1 or 2 on a HotPort 3203. This allows the HotPort to receive power from a PSE device. However, The HotPort 3203 cannot pass-through its PoE feed to a downstream device.

The HotPort 3203 will use up to 14W if operating standalone. The HotPort 3203 will draw as much as 35W when operating as a PSE and powering two other devices (PDs).

HotPort 3203 Installation

This hardware installation guide describes how to install the HotPort 3203 safely. The HotPort is intended to be installed by trained technical professionals. Be sure to read and understand all installation and safety instructions before proceeding with the installation.

Unpacking

The HotPort 3203 package contains the following items. If you are missing any of these items, contact your Firetide reseller.

Mesh Node

- HotPort 3203 with NEMA-4X enclosure with weatherproof connector caps
- Lockable bracket for pole and wall mounting. Designed to fit poles from 37 mm to 50 mm (1.5 in to 2.0 in) diameter. The mounting bracket also has slots for mounting straps for attaching to larger diameter or irregularly shaped poles.

Antenna Assembly

- Two detachable dual-spectrum (2.4 or 5 GHz), 6 dBi, omnidirectional antennas

Note: Each HotPort 3203 comes with two dual-spectrum staging antennas. Use these antennas to determine which RF frequency band (2.4 or 5 GHz) to use in your chosen installation location. After you decide, you can order a single, spectrum-specific (that is, 2.4 or 5 GHz) antenna suitable for your installation from Firetide. Firetide offers a range of antennas, including a high-gain, 8 dBi antenna to use outdoors with your HotPort. Throughout this manual, references are made to the single, high-gain 8 dBi antenna unless the two dual-spectrum antennas shipped with the unit are specifically involved.

Ethernet Transition Cable/RJ-45 Male Connector Kit

- Weatherized Ethernet transition cable (2 m (6.6 ft)), circular, watertight, IP67-rated female to RJ-45/RJ-45 male connector kit with Bulgin connector housing

Power Supply

- Country- or region-specific power cord, power transition cable (10 meters (32.8 ft); 30 m (98.4 ft), and 50 m (164 ft) cable lengths available for order from Firetide) and an indoor-rated power supply

Documentation

- 3203 Hardware Installation Guide (this document)
- 3203 User Guide
- End user license agreement (EULA)
- Warranty and registration card

Compact Disk (CD)

- HotView software
- HotPort 3203 reset application software
- HotView User Guide (PDF file)
- HotPort 3203 User Guide (PDF file)
- HotPort 3203 Hardware Installation Guide (this document in a PDF file)
- Warranty/Registration Card (PDF file)
- EULA (PDF file)

Required Tools and Supplies

Firetide provides the accessories listed in the “Unpacking” section to enable a proper installation.

The following tools and supplies must be provided by the customer:

- #2 Philips screwdriver
- Adjustable wrench
- Wire cutters to cut tie wraps around cables
- Ladders, lifts, and/or platforms to install the HotPort 3203 on poles and structures
- 10 AWG grounding cable to connect the HotPort 3203 to earth ground
- Grounding connectors and grounding rod
- RJ-45 crimping tool – required if connecting a peripheral device, such as an access point or camera. Also need a Category 5 Ethernet cable with at least one RJ-45 connector to connect a peripheral to the HotPort.

- Weatherproofing kit – this kit provides electrical tape and butyl mastic. Check the TESSCO web site (www.tessco.com) for weatherproofing antennas and coaxial cables.
- Hose clamps, band clamps, U-bolts, or similar brackets, suitable for attaching the HotPort 3203 to your chosen antenna mast.
- Hose clamps, band clamps, U-bolts, or similar brackets, suitable for mounting the antennas to your chosen antenna mast.

The following tools and supplies are optional:

- Cordless screwdriver #2 Philips
- Cordless drill
- Antenna stand (used to mount the antenna pole)

Building a Firetide Mesh Network

Although network planning is often not required for basic installations, adhering to a few simple guidelines will help ensure that your network performs reliably and gives you the full benefits and performance that mesh networking has to offer.

Planning Your Network

Before implementing a wireless mesh network, perform the following preliminary steps:

- Survey your site and make a simple sketch of where you'll place the HotPort nodes.
- Make sure that you can install all HotPort nodes close enough to AC power outlets so you can connect the HotPort nodes' AC power supplies to the outlets. (If you plan to use the Power over Ethernet option to power the HotPort, make sure that you can install the HotPort close enough to the Power Sourcing Equipment.)
- As described in detail below, you can increase the working distance of your outdoor, wireless mesh by avoiding obstacles between nodes. For best performance, ensure that there is a clear line of sight between each HotPort node.

See the sections below for more site-planning information.

Understanding HotPort Antenna Patterns

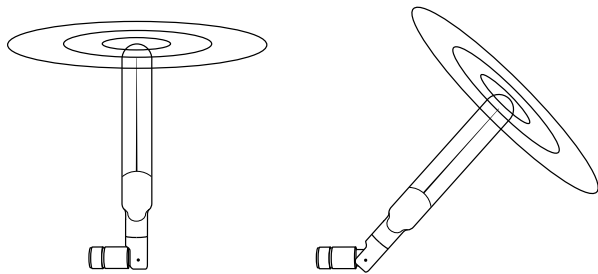

HotPort 3203 outdoor mesh nodes have omni-directional antennas that radiate in a broad circular pattern perpendicular to the antenna shaft. For optimum coverage, orient the antennas in your mesh

network vertically (perpendicular to the ground). Since the coverage of the RF spectrum is different in the various spectrum bands, orientation of the antennas will enhance your coverage area. The two included dual-spectrum antennas support the following frequency bands: 5.150-5.250 GHz; 5.250-5.350 GHz; 5.725-5.850 GHz; 2.420-2.497 GHz (OFDM and DSSS modes).

Line-of-Sight Improves Operating Distance

Although HotPort wireless mesh nodes can communicate through walls and buildings, you can increase the working distance of your nodes by avoiding obstacles made of dense materials, such as concrete, metal, or wood. Positioning the HotPort units so the space between them provides an unobstructed, line-of-sight view will greatly increase the effective range and reliability of transmission. They should be located high enough above obstacles to prevent interference.

Creating a Mesh Topology for Maximum Performance and Reliability

Unlike simple point-to-point bridging, Firetide provides true mesh networking with flexible and redundant paths. This is done automatically, using a proprietary packet-routing protocol developed by Firetide. This protocol improves overall performance, allows the network to be extended over long distances, and reduces the chance of single point failures. To fully benefit from the self-forming and self-healing properties of the mesh, place each HotPort node within direct range of two or more HotPort nodes. It is not recommended to install your HotPort network in a linear, point-to-point configuration. The Firetide network protocol is optimized for two- and three-dimensional topologies.

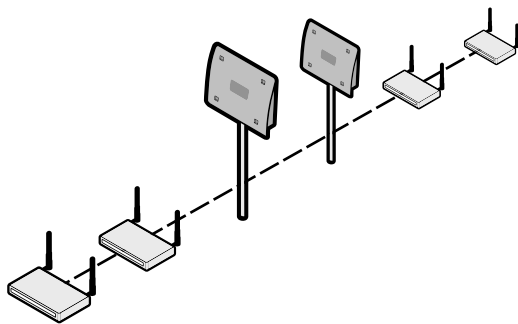

Linear or Point-to-Point Topology (incorrect)

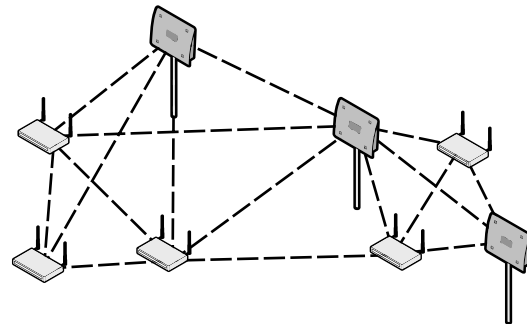

Multipoint to Multipoint Mesh Topology (correct)

Linear vs. Mesh Topology

Staging Considerations

If the antenna, access points, Ethernet devices, and HotPort 3203 are staged properly, the installation should go smoothly. This section describes some staging scenarios that will ease overall installation of the HotPort 3203. Note that the mesh network may consist of a mix of indoor and outdoor HotPort units. Firetide recommends you perform the following steps to install your HotPort 3203:

1. Set up your HotPort 3203 in a lab with all other HotPort units (any combination of HotPort 3203 nodes and HotPort 3100 series nodes) using the two provided dual-spectrum antennas.
2. In the lab, make all the necessary cable connections and power the HotPort units.
3. Install the HotView software on a workstation and connect the workstation to a HotPort 3203 or HotPort 3103 (see the HotView User Guide for information about installing and using HotView).
4. Use HotView to configure the HotPort nodes and create a small mesh network. Configure and test the network settings you plan to use.
5. Once you've decided which RF frequency band to use (2.4 or 5 GHz), order a high-gain antenna for the desired spectrum from Firetide for the HotPort 3203.
6. Pre-assemble the antenna, HotPort 3203, and other devices to a metal pole and antenna stand and then relocate and attach the entire stand to a roof top. It is often easier to install all devices to one object, such as a pole, and then attach the pole to the roof. In many cases, connecting the devices to a pole already attached to the roof top can be difficult and dangerous.
7. Install the antenna first and then install the HotPort 3203 enclosure. This will ensure that the antenna is mounted at an adequate height.
8. A lightning surge suppressor must be used. Some antennas include one. If not, you must install a lightning surge suppressor.
9. Install the antenna and wireless devices higher than the HotPort 3203. Having the HotPort 3203 at a location lower than the antenna will provide easy access to the HotPort 3203. Take care when locating the HotPort 3203 far away from the antenna; a short antenna cable gives better performance than a longer one. Do not mount the HotPort 3203 further than 60 ft (18.3 m) from the antenna.
10. The HotPort 3203 and its antenna must both be grounded. Connect the HotPort 3203 mounting bracket to earth ground. Ground the antenna as well.
11. Use weatherproofing kits that include non-vulcanized rubber to weatherproof connectors and antennas. All Ethernet cables must be waterproofed; standard RJ-45 connectors do not last outdoors.
12. Power over Ethernet: Consider which devices require PoE and what the required input voltage will be. The HotPort 3203 is fully compliant with 802.3af.
13. Connect peripheral devices to the HotPort 3203.
14. Connect power to the HotPort 3203 and peripherals.
15. Connect a workstation running HotView to the HotPort 3203, configure the desired radio channel and RF spectrum settings, and connect to the mesh. Apply the changes to the entire mesh.

These steps are described in detail in this manual.

Preparing the Site for Mounting

Prior to mounting the antenna and enclosure, prepare the site for mounting as described below.

Safety Considerations

Prior to mounting, consider the following safety issues.

- If using a ladder, use approved, non-conducting ladders.
- Use approved and non-conducting shoes and other safety equipment. Make sure that all equipment is in good repair.
- If mounting to a pole or tower, make sure all poles and towers are securely grounded.
- Make sure antenna cables have lightning arrestors.

Weatherproofing

The two Ethernet ports on the bottom of the HotPort 3203 feature circular, watertight IP67-rated connectors. Use the included weatherized Ethernet transition cable/RJ-45 connector kit to connect Ethernet devices with male RJ-45 connectors to the HotPort 3203. Be sure to weatherize the entire Ethernet cable, from end to end.

Preparing Earth Ground



The HotPort 3203 must be properly connected to earth ground. Failure to do so may result in equipment damage, injury, or death. The product warranty does not cover damages resulting in part or in whole from improper grounding. The components that will attract lightning strikes are the antenna, the antenna pole, and the Ethernet and power cables. Below are some guidelines for installing grounding components.

- Having a proper ground is critical. The following steps represent minimum acceptable grounding practices. Consult your location's building and electrical codes regarding antennas and follow them, or consult the National Electric Code (NEC).
- If connecting to a tower or pole, connect the base of the tower or pole directly to the building's ground or to one or more approved grounding rods using 10 AWG ground wire and corrosion-resistant connectors.
- Connect the grounding cable to rain gutters only if the rain gutter or other conductive material is connected to earth ground.
- Grounding rods should be copper and between 6 - 8 ft (1.8 m - 2.4 m) long.
- Install all grounding components in straight lines. If bends are unavoidable, do not make sharp turns.
- Earth-to-ground resistance should not be more than 10 ohms.
- Understanding the soil is very important in order to create a proper earth ground. If your soil is rocky or sandy, drive your ground rods and then pull them back out and dump an approved ground enhancement material into the holes where the grounding rods go. Then replace the grounding rods. Keep in mind that some salt compounds are corrosive and can cause copper to corrode.

Mounting the Antenna

Once you determine which RF frequency band to use, you can order a single, spectrum-specific high-gain antenna from Firetide. This antenna consists of an antenna shaft with an attached lightning protector and coaxial cable, either a 1.5 m (5 ft) or 5 m (16.4 ft) cable.

The following guidelines are important points about mounting the antenna.

Mounting Guidelines

- For best results, the mounting location should be selected to enable maximum performance of the antenna. Generally speaking, a higher antenna will have better overall range and coverage.
- The antenna can be mounted directly to the HotPort 3203 or directly to a pole.
- When using a single antenna, connect it to the Antenna 1 connector of the HotPort 3203. This is the Tx/Rx port. A second antenna may be used on port 2. This is the diversity antenna connector.
- The pole composition can be either metal or wood. The supplied brackets fit poles from 37 mm to 50 mm (1.5 in to 2.0 in) diameter.

- The antenna should not be within 3 ft (0.9 m) of any metal bar or structures, and ideally not within 3 ft (0.9 m) of any concrete or stone structure. If possible, locate the antenna as far from such objects as practicable.
- HotPorts should not be placed where trees or foliage are in the line-of-sight path between any pair of units.

Note: Use of components not supplied by Firetide is not supported and will void the warranty.

- If a longer coax cable is required, the connector requires a 50 ohm RP-TNC (Reverse-Polarity TNC) cable.

Note: Shorter antenna cables give better performance. Plan your installation to minimize antenna cable length. However, do not attempt to splice or shorten the antenna cable.

Note: Do not mount the HotPort antenna within 3 ft (0.9 m) of other antennas. If you do, interference may occur.

- When mounting next to an access point, mount the access point lower on the pole and at least 3 ft (0.9 m) from the antenna. You can also mount the access point on a horizontal bar to achieve the required 3 foot separation.

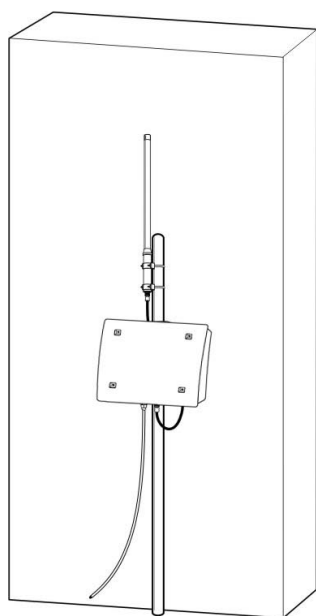

Incorrect

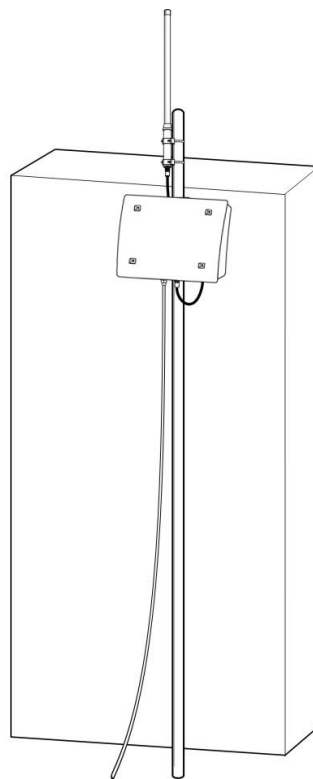

Correct

For best results, position the HotPort 3203 antenna above obstructions.

Wall Mounting

1. Position the antenna above or to the side of the HotPort 3203 enclosure to permit easy attachment of the antenna to the connector at the bottom of the enclosure.
2. RF signals can be attenuated by a wall or the composition of a building. When utilizing omni-directional antennas, connecting the antennas to a wall may limit the amount of coverage.
3. Connect the end of the cable from the antenna to the antenna 1 connector at the bottom of the HotPort 3203 enclosure. Place the provided waterproof cap on the antenna 2 connector to cover it.

Pole Mounting

1. Position the antenna on the pole above the HotPort 3203 enclosure.
2. Clamp the antenna securely to the pole using two U bolts per antenna.
3. Connect the end of the cable from the antenna to the antenna 1 connector at the bottom of the HotPort 3203 enclosure. Place the provided waterproof cap on the antenna 2 connector to cover it.

Antenna 1 is the primary Rx/Tx antenna. Antenna 2 provides diversity, which eliminates potential dead spots. Antenna 2 is not required, but should be considered in any application with coverage problems. Signal reflections from objects in the area create multiple propagation paths; which can lead to nulls (dead spots). A second antenna provides an alternate reception path and eliminates this problem.

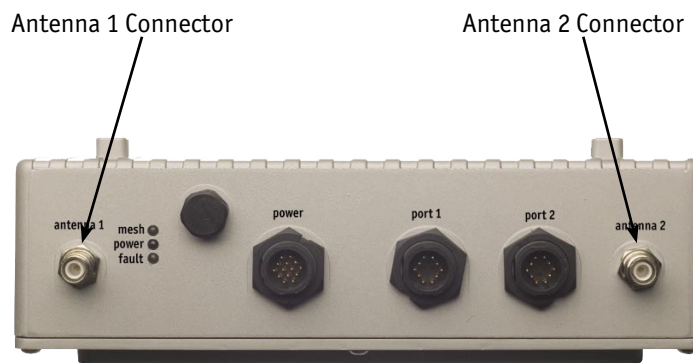

HotPort 3203 Rear/Bottom Panel

For a detailed drawing on how the antenna connects to the pole, refer to the diagram on the next page.

Note: Do not mount the antenna pole near power lines.

Note: If a longer coax cable is required, contact your local distributor to obtain a 50 ohm RP-TNC (Reverse-Polarity TNC) cable. In order to maintain proper system operations, there cannot be more than 8 dB of insertion loss between the HotPort 3203 and the antenna. Insertion loss is defined as the loss of signal strength when a cable is inserted between the transmitter and the receiver. Insertion loss is measured in dB.

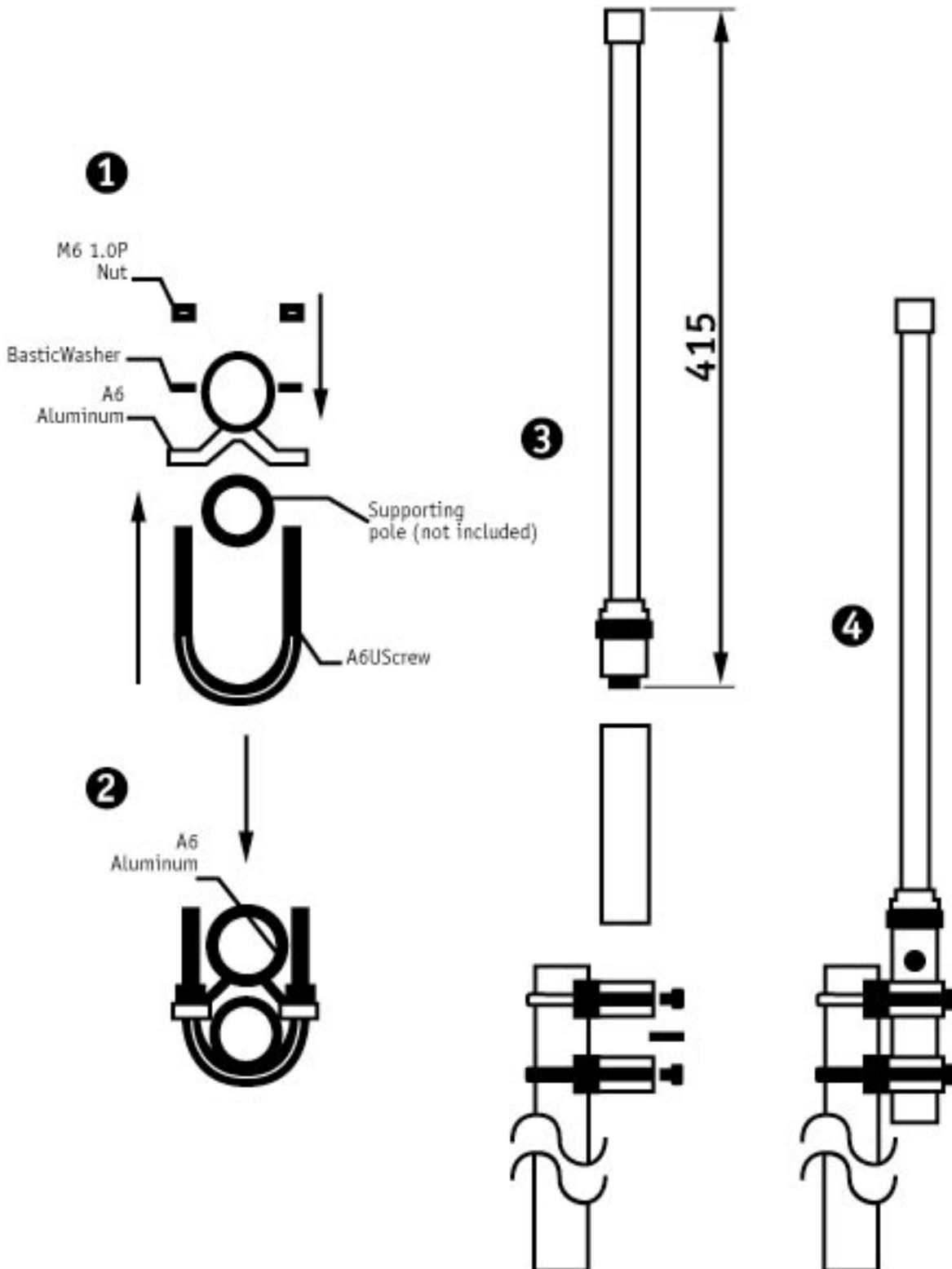

High-Gain Antenna Assembly for HotPort 3203

Mounting the Enclosure

The HotPort 3203 enclosure should be mounted securely to a wall/wood structure or a pole approximately 1.5" (37 mm) to 2" (50 mm) in diameter. You can also mount the enclosure to a wall, light poles, and irregularly shaped poles.

Mounting Guidelines

- For best results, the location should enable maximum performance of the antenna and any attached devices, such as access points or cameras. When possible, provide clear line-of-sight access for the antennas. You can test various locations by mounting the unit to a portable stand until you can determine the ideal location for permanent mounting.
- The location must allow for a solid connection to earth ground. Be sure the earth ground wire or strap does not obstruct access to the enclosure.
- The unit must be within reach of the power cord/power transition cable to an AC outlet for power (a 10 m (33 ft) power transition cable is provided; longer cables are available for order from your Firetide dealer). Note: AC power is not required if the HotPort 3203 will receive power via Power over Ethernet from Power Sourcing Equipment.

Wall Mounting

1. Use four screws to attach the universal mounting bracket securely to the wall using the four holes near the top and bottom of the universal mounting bracket. Use appropriate anchors when attaching to masonry or other materials.
2. Attach the enclosure to the universal mounting bracket by sliding the metal clips on the back of the enclosure into the metal straps on the universal mounting bracket.
3. Secure the enclosure to the universal mounting bracket using the four captive screws on the sides on the universal mounting bracket.

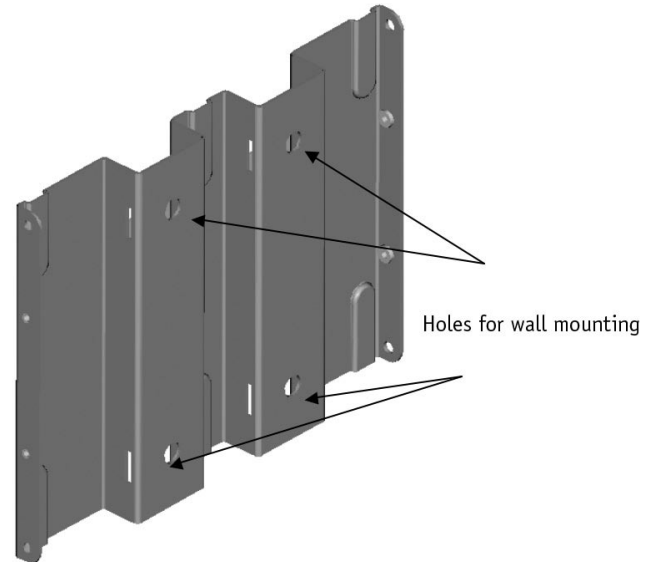

Holes in Universal Mounting Bracket for Wall Mounting

Pole Mounting

You can mount the HotPort 3203 to a pole using U bolts. The section below describes how to mount the enclosure to a 1.5" (37 mm) or 2" (50 mm) pole.

Using U Bolts

1. Position the pole mounting bracket against the pole. Insert the U bolts from behind the pole and through the pole mounting bracket.
2. Insert the two U bolts through the four holes near the top and bottom of the universal mounting bracket.
3. On each U bolt threaded shaft, place a washer, a lock washer, and one or more 6 mm nuts as spacers.
4. Use four lock washers and 6 mm nuts to secure the universal mounting bracket, pole mounting bracket, and U bolts assembly.
5. Attach the enclosure to the universal mounting bracket by sliding the metal clips on the back of the enclosure into the metal straps on the universal mounting bracket.
6. Secure the enclosure to the universal mounting bracket using the four captive screws on the sides of the universal mounting bracket.

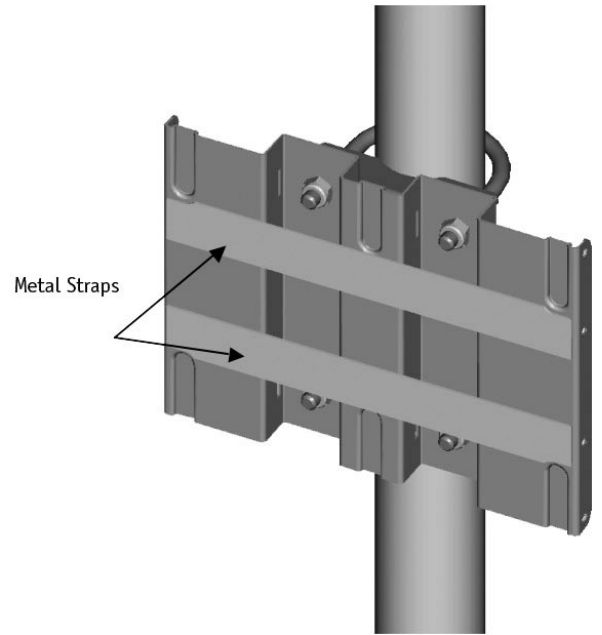

Universal Mounting Bracket Attached to Pole

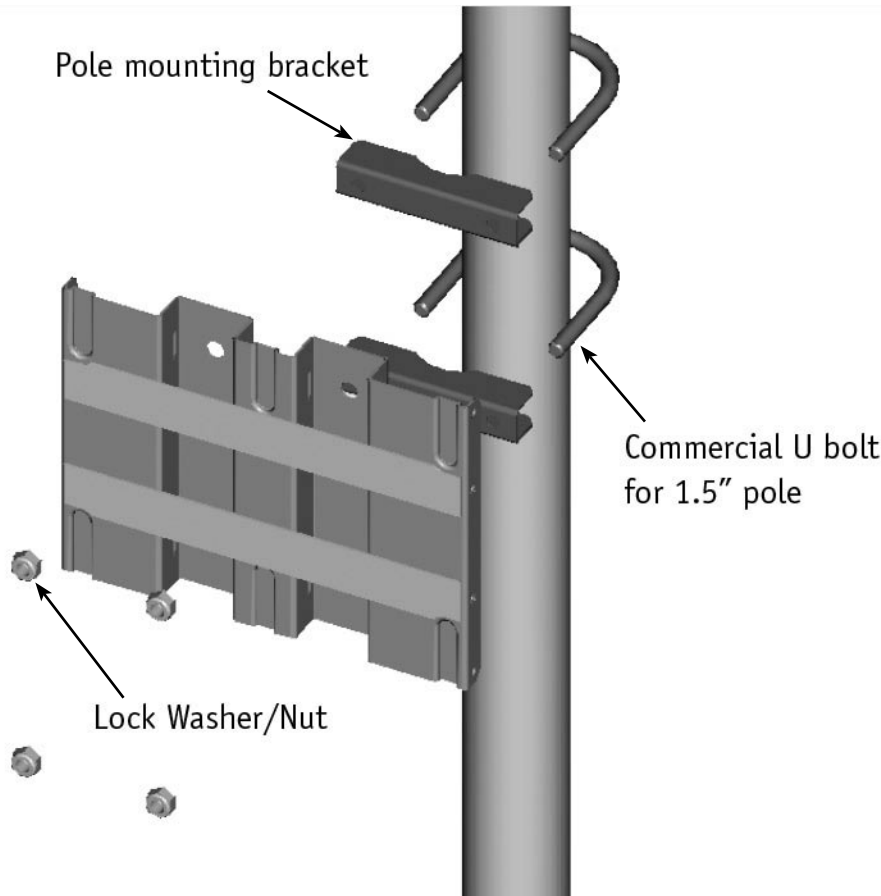

Exploded Pole Mounting Diagram

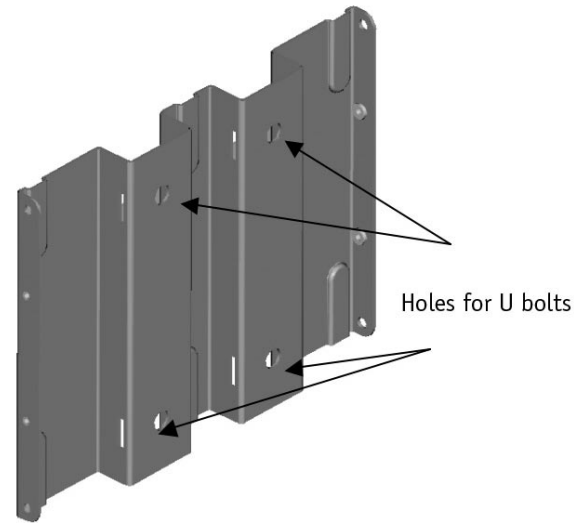

Holes in Universal Mounting Bracket for U Bolts

Using Mounting Straps

For poles with diameters larger than 2" (50 mm), horizontal poles, irregularly shaped poles, or lighting lamps, you can use mounting straps to mount the HotPort 3203 enclosure.

1. Position the universal mounting bracket against the pole.
2. Thread two mounting straps around the pole and through the slots located near the top and bottom of the universal mounting bracket. Secure the mounting straps.
3. Attach the enclosure to the universal mounting bracket by sliding the metal clips on the back of the enclosure into the metal straps on the universal mounting bracket.
4. Secure the enclosure to the universal mounting bracket using the four captive screws on the sides of the universal mounting bracket.

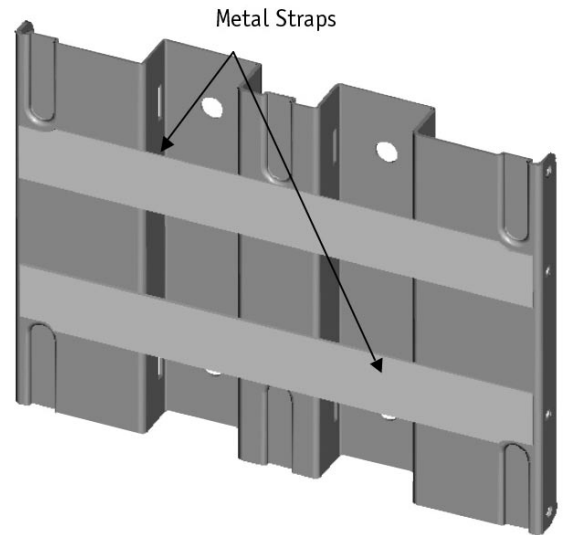

Metal Straps on Universal Mounting Bracket

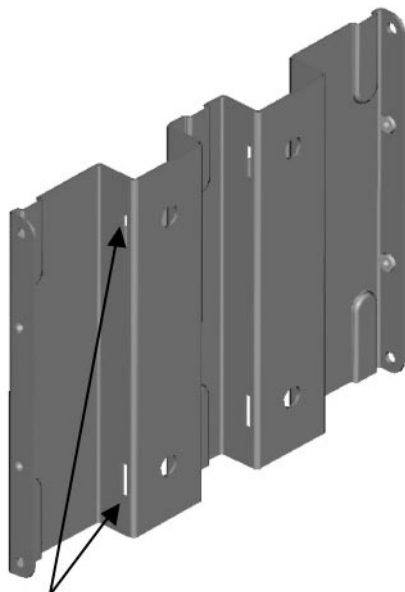

Slots for mounting straps

Slot Access - Pole Side

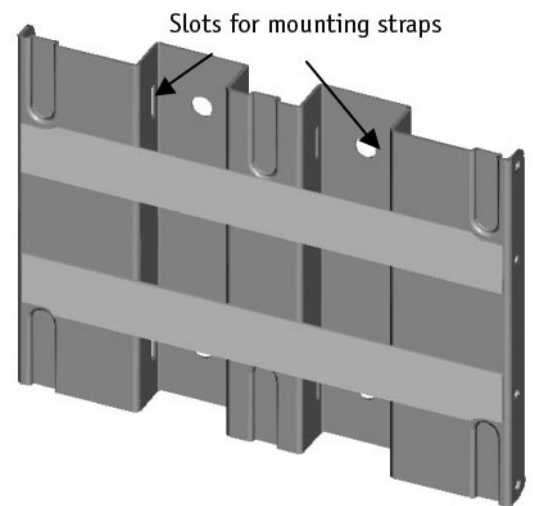

Slot Access - HotPort Side

Installing the Sunshield

You can install the provided sunshield on the enclosure to help protect it from the elements.

1. Align the four holes in the sunshield with the four risers on the enclosure.
2. Use the provided four machine screws to attach the sunshield to the enclosure.



Connecting the Power

There are three ways to provide power to the HotPort 3203:

- AC: Connect the provided power supply to an AC power outlet and then to the HotPort 3203. This option allows you to provide power to up to two peripheral devices connected to the HotPort 3203.
- PoE (Power over Ethernet option): Connect Power Sourcing Equipment to the HotPort 3203 .
- DC: Use an external battery and/or solar cell arrangement to provide direct DC power.



HotPort 3203 Rear/Bottom Panel

Connecting AC Power

Use the supplied country- or region specific power cord, power transition cable, and power supply to provide power to the HotPort 3203 enclosure from an AC outlet.

1. Connect the female plug on the country- or region specific power cord to the power supply.
2. Connect the four-pin plug on the power transition cable to the power supply.
3. Run the power transition cable from the AC outlet location to the HotPort 3203 enclosure.
4. Remove the protective cap from the DC input connector on the HotPort 3203 enclosure and attach the six-pin connector on the power transition cable to the DC input connector on the HotPort. Twist the connector until it snaps into place to ensure a watertight seal.
5. Plug the free end of the country- or region specific power cord into an AC outlet. The indicators (LEDs) on the enclosure should light as follows: during and after system startup, the green Power indicator will light. After system startup, once the node is able to mesh with other HotPort nodes, the Mesh indicator will light up in green. If the Fault indicator lights up in red, this indicates a fault condition.

Connecting Power over Ethernet

You can provide power to a HotPort 3203 by connecting Power Sourcing Equipment (PSE) to Ethernet port 1 on the HotPort 3203. In this configuration, the HotPort 3203 receives its power from the PSE. When receiving power from a PSE device, the HotPort 3203 functions as a Powered Device (PD) as defined by the 802.3af standard. Port 1 remains a data port as well.

Below are some notes regarding this type of connection:

- The Power Sourcing Equipment (PSE) must comply with the IEEE 802.3af specification for Power over Ethernet.
- It is recommended that you use a shielded Category 5 Ethernet cable no longer than 2 m (6.5 ft) to connect Power Sourcing Equipment to a HotPort.
- If you apply Power over Ethernet to the HotPort, you cannot provide power to a peripheral connected to Ethernet port 2, that is, the HotPort 3203 will not 'daisy-chain' PoE. However, you can connect a peripheral to Ethernet port 2 to allow the peripheral to exchange data with the HotPort 3203.



Note: If you provide Power over Ethernet to the HotPort 3203, do not connect or use the HotPort power supply.

Each HotPort comes with a weatherized Ethernet transition cable which is PoE compatible. This circular, 10-pin connector on the Ethernet transition cable connects to Ethernet port 1 on the HotPort. A weatherized RJ-45 male connector kit is also included. You need to construct a shielded Ethernet cable compatible with outdoor applications to connect the PSE to the Ethernet transition cable.

To connect power to the unit from PSE:

1. Construct a shielded Category 5 Ethernet cable:
 - (a) Insert one end of the Ethernet cable (without an RJ-45 connector) through the provided connector housing.
 - (b) Use an RJ-45 crimping tool to attach an RJ-45 connector to this end of the Ethernet cable (strip off a section of the outer jacket, separate the wire pairs, align the wires in the correct order (straight or crossover), and so crimp).
 - (c) Attach a connector compatible with the PSE to the other end of the Ethernet cable (typically an RJ-45 connector).
2. Run the Ethernet cable you constructed from the PSE to the HotPort 3203 enclosure.

3. Insert the male RJ-45 connector on the constructed Ethernet cable into the female-to-female Ethernet coupler.



Waterproof RJ-45 Coupler

4. Connect the male RJ-45 connector on the Firetide-supplied Ethernet transition cable to the female-to-female coupler.
5. Remove the protective cap from Ethernet port 1 on the HotPort 3203 enclosure and insert the circular, 10-pin connector on the Ethernet transition cable into Ethernet port 1 on the HotPort 3203.
6. Tighten all connectors to ensure a watertight seal.
7. Connect the other end of the Ethernet cable to the PSE and power the HotPort and PSE. The indicators (LEDs) on the enclosure should light as follows: during and after system startup, the green Power indicator will light. After system startup, once the node is able to mesh with other HotPort nodes, the Mesh indicator will light up in green. If the Fault indicator lights up in red, this indicates a fault condition.

Note: Regardless of your exact configuration of Ethernet cable and power sources, you must make sure all cables and connections are completely waterproofed. It is a good installation practice to leave enough cable slack so that there is a drip loop in each cable. This provides a low point for water to drip off the cable, rather than running down to a connector.

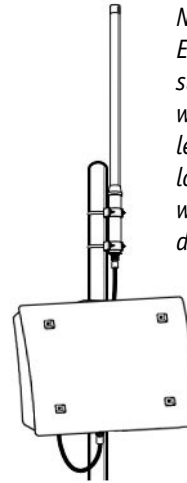

Drip Loop

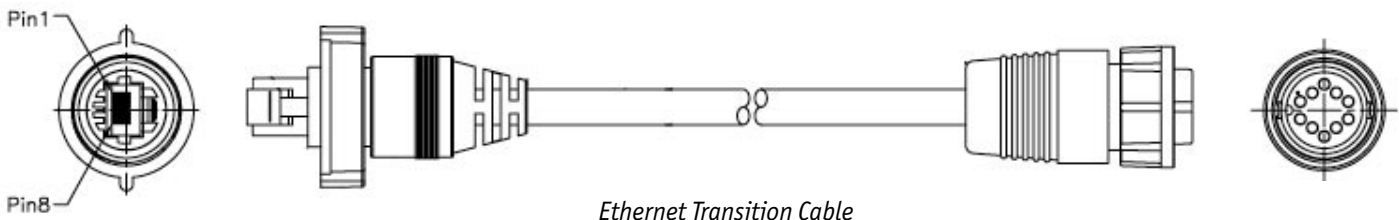

Ethernet Transition Cable

Connecting an External Battery Backup System or Solar Power

The HotPort 3203 can be powered directly via a DC power source of the proper input rating. See the Power section of Appendix C for the appropriate input power specifications. The interface procedure varies considerably, depending upon whether your power source comes directly from the battery, via a circuit breaker, or through a load distribution block. Battery capacity is contingent upon the total power budget required at each node (e.g., the total power consumption of all devices), the charging capacity, and the number of operating hours in reserve required of the battery backup system. Contact your Firetide dealer for more information on their solutions.

Optionally, battery backup systems can be powered and charged via a solar panel array. These are also very customized depending upon your power requirements. Geographic location affects the minimum peak sun hours in a particular latitude, which in turn determines the bracket angle supporting the most optimal panel tilt. The size of the array—the number of panels—is contingent upon the power budget requirements of a particular node. Note that the HotPort node is not aware of the type of power input source (AC, DC via battery, DC via battery with solar charging).

Connecting Peripherals

You can connect up to two peripheral devices, such as access points or surveillance cameras, to the Ethernet connectors on the bottom of the HotPort 3203. Each HotPort node provides two auto-sensing 10/100 Mbps Ethernet connectors. Optionally, these peripheral devices can also receive power from the HotPort.

Each HotPort comes with a weatherized Ethernet transition cable/ RJ-45 male connector kit. The circular, 10-pin connector on the Ethernet transition cable connects to one of the circular Ethernet ports on the HotPort. You need to construct a shielded Category 5 Ethernet cable compatible with outdoor applications to connect the peripheral to the Ethernet transition cable/ RJ-45 male connector kit.

To connect a peripheral device:

1. Construct a shielded Category 5 Ethernet cable: Insert one end of the Ethernet cable (without an RJ-45 connector) through the provided Bulgin connector housing. Then use an RJ-45 crimping tool to attach an RJ-45 connector to this end of the Ethernet cable (strip off a section of the outer jacket near the end of the cable, separate the wire pairs, align the wires in the correct order (straight-through or cross-over), and so on). Attach a connector compatible with the peripheral to the other end of the Ethernet cable (this is typically another RJ-45 connector).
2. Run the Ethernet cable you constructed from the peripheral to the HotPort 3203 enclosure.
3. Insert the male RJ-45 connector on the constructed Ethernet cable (on the Bulgin connector housing end) into the female RJ-45 connector on the Ethernet transition cable/ RJ-45 male connector kit.
4. Twist the Bulgin connector housing to ensure a watertight seal.
5. Remove the protective cap from one of the Ethernet ports on the HotPort 3203 enclosure and insert the circular, 10-pin connector on the Ethernet transition cable into the Ethernet port on the HotPort 3203. Tighten the connector to ensure a watertight seal.
6. Connect the other end of the Ethernet cable to the peripheral and power the HotPort and the peripheral. The indicators (LEDs) on the enclosure should light as follows: during and after system startup, the green Power indicator will light. After system startup, once the node is able to mesh with other HotPort nodes, the Mesh indicator will light up in green. If the Fault indicator lights up in red, this indicates a fault condition.

Note: If you also want to provide power to the peripheral device(s), see the section below.

Note: Each HotPort 3203 package includes one Ethernet transition cable/RJ-45 connector kit. To connect another peripheral to the HotPort, order another transition cable/RJ-45 connector kit from your Firetide dealer.

Providing Power over Ethernet to Peripherals

Optionally, one or two peripheral devices attached to a HotPort 3203 can receive DC power, as well as data, from the HotPort. Total power used by the peripherals must not exceed 21W. You can use either port on the HotPort 3203 to connect peripherals. Follow the instructions in the above section to connect peripheral devices that will receive their power from the HotPort.

Note: To provide power to peripheral devices attached to the HotPort, you must connect AC power to the HotPort (see the “Connecting AC Power” section for details).

When connecting devices that will receive their power from the HotPort 3203, keep the points listed below in mind.

- When providing power to other devices, the HotPort 3203 functions as Endpoint Power Sourcing Equipment. Do not daisy chain PoE devices; connect only one device per Ethernet port on the HotPort.
- Use shielded Category 5 Ethernet cables compatible with outdoor applications to connect peripherals.
- The devices receiving power from the HotPort 3203 are Powered Devices and must comply with the 802.3af specification for Power over Ethernet.
- The default voltage for power output over each Ethernet port is 48 VDC.
- Consider the distances and the lower voltages of attached devices when receiving Power over Ethernet. When providing Power over Ethernet to attached peripherals, the HotPort can provide a cumulative 27 watts of power, from 48 VDC to 12 VDC. Lower voltage access points and other devices may not work well with PoE if the devices and the HotPort 3203 are too far apart. If the devices are too far apart, you will encounter noise and drooping on the voltage signal. It is recommended that you use an Ethernet cable no longer than 2 m (6.5 ft) to connect a peripheral device that will receive its power from the HotPort. It is also recommended to use higher voltage access points and devices when using PoE.

Note: Save the weatherproof caps on the enclosure in the event that you need to utilize them in the future.

Starting Up and Connecting to the Mesh

The section below describes what the indicators (LEDs) on the enclosure display before and after system startup and how to connect your HotPort 3203 to a wireless mesh.

Startup Sequence

Each HotPort node has indicators (LEDs) on the rear/bottom of the enclosure. These indicators provide status information about the node. The table below describes each indicator, what the indicator displays at system startup, and what the indicator displays after system startup is complete.

Indicator	Startup Indicator Functions	Post-Startup Indicator Functions
Power	During startup, this indicator remains continuously on.	After startup, this indicator remains continuously on to indicate that the HotPort node is receiving power.
Fault	During startup, this indicator is off.	If this indicator lights up in red, this indicates a fault condition.
Mesh	During startup, this indicator is off, indicating that the node is not meshed with other HotPort nodes.	After startup, this indicator will light up in green once the node meshes with other HotPort nodes. If the indicator remains off after system startup, this indicates that the node has not meshed with other HotPort nodes.

Connecting to the Mesh

The recommended way to connect to the mesh is shown in the diagram below. If you have an indoor HotPort, you can communicate with the mesh via the indoor HotPort. Connect a workstation running the HotView software to the indoor node via an Ethernet cable.

If you do not have an indoor HotPort, connect a workstation running the HotView software to the HotPort 3203 via an Ethernet cable and Ethernet transition cable/RJ-45 connector kit (see the "Connecting Peripherals" section for more information on cable connections).

See the 3203 User Guide for details on connecting to the mesh and using your indoor HotPort. See the HotView User Guide for details on the HotView software.

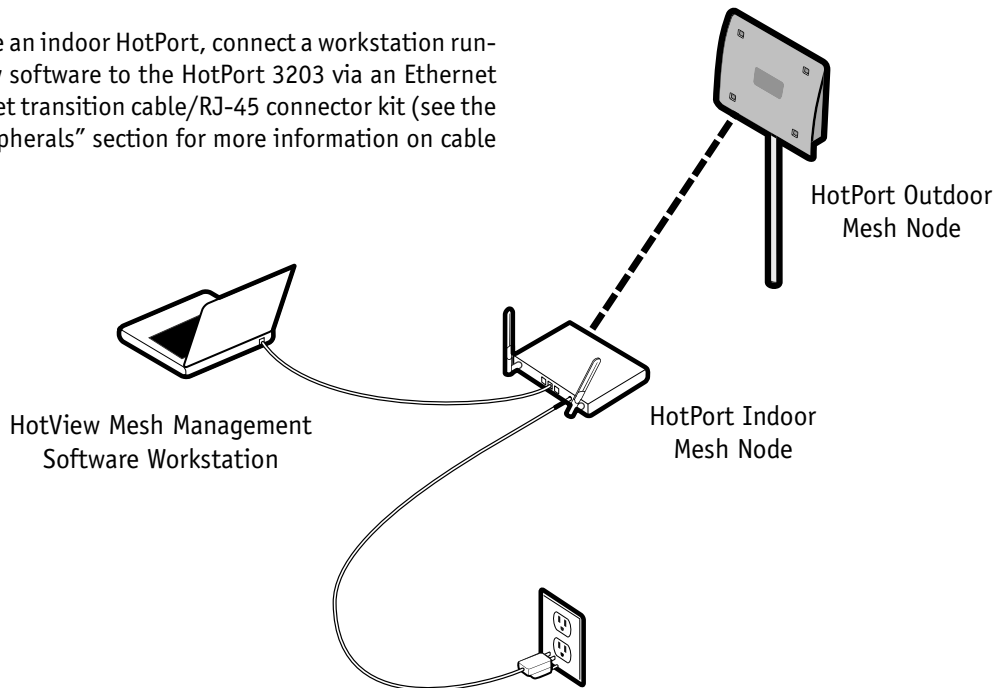

Connecting a Workstation Running HotView Software

Appendix A

Contacting Firetide

As a Firetide customer, you are entitled to receive free support services on our web site and from your authorized Firetide dealer.

Register with Us Now to Access our Support Web Site

Registering as a customer on our web site entitles you to free information and materials to help you get the most from your Firetide mesh network. Visit www.firetide.com/support for information on becoming a registered customer and for access to our support materials.

Dealer Provided Technical Support and Warranty Services

If you need additional technical assistance that is not available on our web site, please contact your Firetide dealer directly. All authorized Firetide dealers are trained and authorized to provide technical support and warranty services for our products and have qualified technical staff available to help you build and maintain your Firetide mesh network.

Product Returns

Please contact your Firetide dealer for instructions on returning defective or damaged products for repair or replacement. Do not return products to Firetide, Inc. Please keep all original packaging materials in the event they are needed to return the product for servicing.

Sales Assistance

If you need additional HotPort wireless mesh nodes or accessories, please contact your Firetide dealer directly. If you do not know your dealer's name, simply email sales@firetide.com and we will send you the dealer information you need. To help us provide the best service possible, be sure to include your phone number, address, and the serial numbers of the HotPort nodes at your location.

Appendix B

Connectors

HotPort 3203 Ethernet Transition Cable Pin Descriptions

Circular, Watertight IP66-Rated Connector and Port Pin Descriptions

Connector Pin #	Wire Color	Port Pin #
1	White/Orange	1
2	Orange	2
3	White/Green	3
4	Blue	4
5	White/Blue	5
6	Green	6
7	White/Brown	7
8	Brown	8
	Drain Wire	9
	Drain Wire	10

RJ-45 Connector Pin Descriptions

Pin #	Signal	Description
1	TXD+	TX Data 10 BaseT/100 BaseTX
2	TXD-	TX Data 10 BaseT/100 BaseTX
3	RXD+	RX Data 10 BaseT/100 BaseTX
4	PoE+	Power Input 5 VDC to 48 VDC +
5	PoE+	Power Input 5 VDC to 48 VDC +
6	RXD-	RX Data 10 BaseT/100BaseTX
7	PoE-	Power Input 5 VDC to 48 VDC -
8	PoE-	Power Input 5 VDC to 48 VDC -

Power Transition Cable Pin Descriptions

The following section describes the pinout for the indoor-rated power supply power transition cable. The power to HotPort 3203 is 12 to 24 VDC, up to 2A. The HotPort can provide 12–48 VDC power (PoE) to devices connected to it.

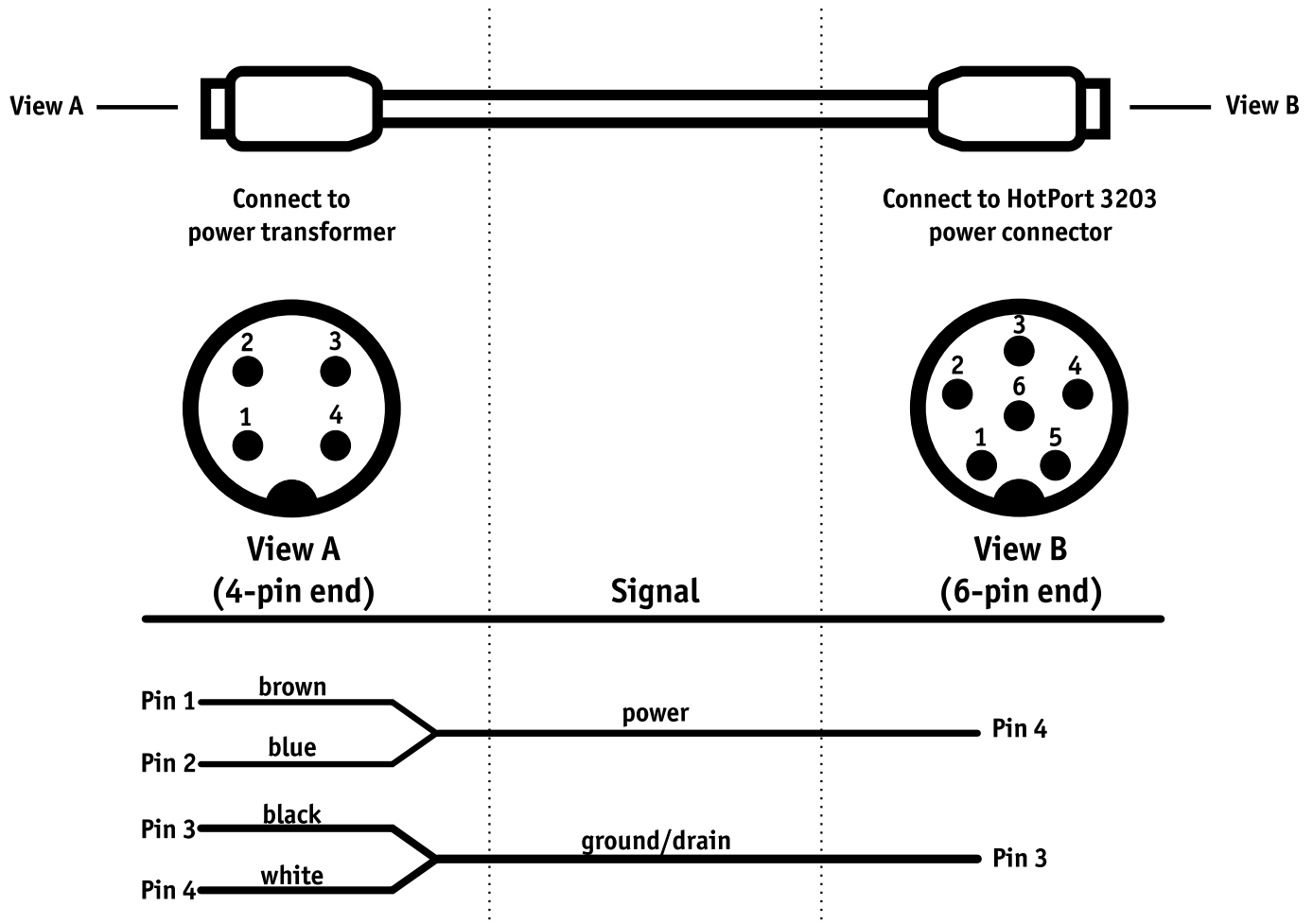

Appendix C - Specifications

Model

HotPort 3203

Wireless interface

2.4 GHz spectrum

- 2.400–2.497 GHz
(actual channels available for use are subject to country-specific regulatory approvals)
- TX Power: Up to 4 W EIRP depending on country of operation, spectrum, and antenna configuration

4.9 GHz spectrum - US Public Safety bands only

5 GHz spectrum

- 5.150 – 5.250 GHz
- 5.250 – 5.350 GHz
- 5.725 - 5.850 GHz
(actual channels available for use are subject to country-specific regulatory approvals)
- TX Power: Up to 1 W EIRP depending on country of operation and antenna configuration

Dynamic Frequency Selection (DFS)

Transmit Power Control (TPC)

Antennas

- Two detachable, 6 dBi omni-directional, vertical polarization, dual spectrum antennas (included for staging only)
- Spectrum: 2.4 GHz and 5 GHz
- Connectors: TNC reverse polarity
- Length: 16.5 in. (42 cm)
- Range: up to 2600 ft (800 m) depending on spectrum and environmental attenuation

Firetide offers a range of recommended antennas. Contact the factory for details.

Network ports

- Dual 10/100 Mbps Ethernet ports with circular, watertight IP67-rated connectors
- IEEE 802.3, 802.3u compliant
- CSMA/CD 10/100 autosense

Encryption

- 40/64 bit, 104/128 bit WEP keys
- 128-bit, 256-bit AES keys

Power

- Input voltage: 12 to 24VDC
- Indoor-rated power supply (transformer): 100-240 VAC, 50/60 Hz, 1.5A
- Power consumption:
up to 14W with no POE load
up to 35W with POE load
- Power transition cable: 32.8 ft (10m)
- IEEE 802.3af compliant PoE (PD and PSE)
Power Sourcing Equipment (PSE) nominal 48VDC \pm 10%, negotiable per 802.3af
Powered Device (PD): 48VDC \pm 25% input

Mesh Management Software

Includes HotView mesh management software

Warranty

One year limited warranty (see warranty card for details)

Enclosure

- Cast aluminum NEMA-4X/IP67 enclosure
- Two antenna connectors (TNC reverse polarity)
- One power connector
- Two circular, watertight IP67-rated Ethernet data connectors
- System indicator LEDs (Power, Mesh, Fault)
- Physical security via lockable mounting bracket
- Weight: 4.85 lbs (2.2 Kg) with sun shield
- Dimensions: 9.812" x 7.812" x 2.687" (25 cm x 19.8 cm x 6.82 cm)

Environmental specifications

- Operating temperature: -40°C to +55°C (-40°F to 131°F)
- Storage temperature: -40°C to +80°C (-40°F to 176°F)
- Humidity 5% to 100%. Accumulation of snow or ice may degrade unit operation.
- Storage humidity (non-condensing): 10% to 90%

Included Accessories

- Lockable bracket for pole and wall mounting
- Indoor-rated power supply
- Sun shield
- One weatherized Ethernet transition cable (circular, watertight IP66-rated connector to RJ-45 connector)
- Weatherized RJ-45 connector kit

Regulatory Agency Certifications

US FCC ID REP-3200-2. Contact your Firetide dealer for product availability and certifications for other countries.

FCC Radiation Exposure Statement

The antenna used for this transmitter must be installed to provide a separation distance of at least 35 cm from all persons and must not be co-located or operating in conjunction with any other antenna or transmitter. OEM Integrators, end-users and installers must be provided with antenna installation instructions and transmitter operating conditions for satisfying RF exposure compliance.

Public Safety Band

Pursuant to Part 90.1215, use of antennas with gain greater than 9 dBi and up to 26 dBi in the 4.940 – 4.990 GHz Public Safety band is permissible without reduction of TX output power. The antenna shall have a directional gain pattern in order to meet the requirement of point to point and point to multi-point operation.

