

Bluetooth Embedded Module

FB155BC User Guide

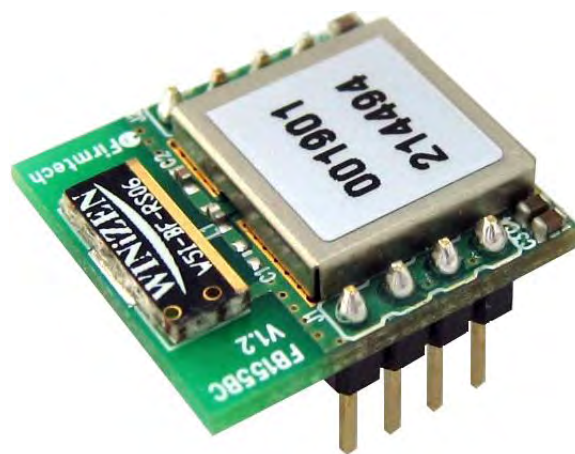

Version 2.1



FIRMTECH Co., Ltd.

Homepage : <http://www.firmtech.co.kr>

Mail : contact@firmtech.co.kr

Tel : +82-31-719-4812

Fax : +82-31-719-4834

Revision History

Revision	Date	Change Descriptions
2.0	05-10-2007	- Write a draft
2.1	15-12-2008	- Connecting with Connection WIZARD - PC Configuration using Config tool

(C) Copyright FIRMTECH Co., Ltd. 2005**All rights reserved**

The products and operation descriptions contained herein shall be protected by copyright law.

Any part or whole of products or operation description shall not be copied, reproduced, translated, nor transformed into readable form by electronic device or machines, without prior consent in writing by FIRMTECH Co., Ltd.

There might be some misprinting or technical faults in the products and operation description which are subject to change without prior notice.

List of Content

1 What is Bluetooth?	5
1.1 Features of Bluetooth	5
1.2 Operation of Bluetooth	5
2 Product Overview	6
3 Product Components	7
3.1 FB155BC	7
3.2 PC Interface Kit (Option)	7
4 Product Appearance	8
4.1 FB155BC Dimension	8
4.2 FB155BC PIN Assign	8
5 Interface (Pin Connection)	10
5.1 Without Flow Control	10
5.2 With Flow Control	10
6 PC Interface Board (Jig Board)	11
7 Performance of Products	13
8 Current Consumption	14
9 Preliminary Product Components	15
10 Connecting the wireless section of Bluetooth	16
10.1 Connecting with Connection WIZARD	16
10.2 Connection with AT commands	19
11 How to complete PC Configuration?	20
11.1 PC Configuration using BTConfig tool	20
11.2 PC Configuration using Serial Communication (Hyper Terminal) Program	23
12 Approval Information	28
12.1 MIC	28
12.2 FCC compliance Information	28
12.3 CE	28
12.4 TELEC	28
12.5 SIG	28

1 What is Bluetooth?

1.1 Features of Bluetooth

- Objectives of Bluetooth : To Realize Wireless Communication for Short Distance with Low Power Consumption, High Reliability, and Low Cost.
- Frequency in Use: To Use ISM(Industrial, Scientific, Medical) Band which does not require any permission to use.
 - 2.400 – 2.4835 GHz, 79 channels
 - 2.465 – 2.4835 GHz, 23 channels (in France)
- Transmission Rate : 1Mbps ~ 3Mbps
- Transmission Output : 1mW (10m, Class2), 100mW (100m Class1)
- Network Configuration : Configured with Master and Slave relation. A Bluetooth unit shall allow simultaneous connections up to 7 devices (in case of ACL).
- Reliability : To Guarantee stable wireless communication even under severe noisy environment through adopting the technique of FHSS (Frequency Hopping Spread Spectrum).

1.2 Operation of Bluetooth

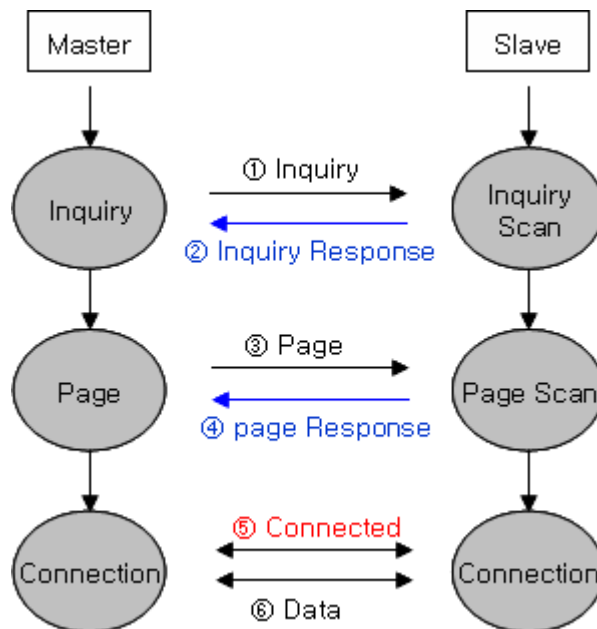

<Feature 1-1 Bluetooth Operation>

- Bluetooth operates based on the connection between "Master" and "Slave".
- Masters are simply supposed to do "Inquiry" and "Page". Slaves are supposed to do "Inquiry Scan" and "Page Scan".
- If a Master finds a Slave and so "inquiry" is successful, a Slave responds to the Master with its information.
- Interconnection between the Master and the Slave is achieved only if the information from the Slave is corresponded with the Master, and the Slave sends data to the Master.

2 Product Overview

FB155BC has been developed to replace the previous RS232 Cable system with wireless communication system to use.

Major Features of FB155BC

1. Bluetooth Specification 2.0 Support
2. Easily applicable to the Product with 8Pins Header type
3. Support AT Command, and capable to control FB155BC by using AT Command.
4. Easy to connect to use with Bluetooth PDA, Bluetooth USB Dongle, etc.
5. Provides the most compact size among Class 2 EDR.
6. Simply support the function of Bluetooth Firmware Update
7. Stable Data Transmission / Receipt

※ We request the new users of FB155BC to read the information on this description carefully before they start to use the products.





3 Product Components

3.1 FB155BC

MODEL	PICTURE	Q'TY (EA)
FB155BC (On-board Chip Antenna)		1

<Table 3-1 Basic Components of FB155BC>

3.2 PC Interface Kit (Option)

MODEL	PICTURE	Q'TY (EA)
FBZx5Xxx (Interface Board)		1
FCA180SC (RS232 Serial Cable)		1
FCA100UC (USB Power Cable)		1
FCA001PO (DC Power Adapter - 5V) (Option)		1

<Table 3-2 Components of PC Interface Kit >

※ If you find any of above components is defective, or not included in the package, please contact the seller you purchased.

4 Product Appearance

4.1 FB155BC Dimension

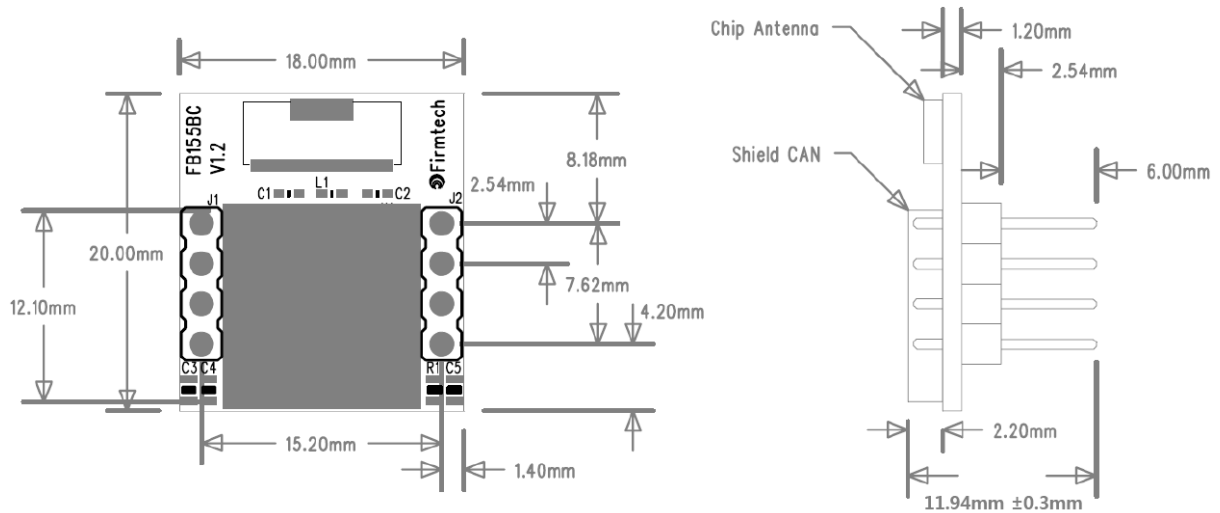

<Figure 4-1 FB155BC Dimension>

4.2 FB155BC PIN Assign

GND 1 VCC 2 STATUS 3 FACTORY RESET 4	8 RXD 7 TXD 6 RTS 5 CTS
---	----------------------------------

Dimension : 18(Width) x 20(Length) x 12(Height) mm

<Figure 4-2 FB155BC PIN Assign>

No.	Name of Signal	Features	I / O	Level
1	GND	Ground		
2	VCC	3.3V DC	Input	
3	STATUS	STATUS LED	Output	TTL

4	FA SET	Factory Reset Go back default setting	Input	TTL
5	UART_CTS	UART Clear To Send	Input	TTL
6	UART_RTS	UART Ready To Send	Output	TTL
7	TXD	Transfer Data (Data out)	Output	TTL
8	RXD	Received Data (Data in)	Input	TTL

<Table 4-1 Pin Description>

- Hard Reset(Factory Reset)

To return to the factory reset, input LOW signal (0V) to FA_SET (No 4 PIN) for more than 2 seconds then all the set value shall be changed to the initial factory set value.

- STATUS port

To be used to monitor the status of FB155BC.

To keep LOW(0V) when the two devices are communicable since the connection between wireless range is smoothly made.

In standby mode for connection with Bluetooth, or connection trial, or searching for around Bluetooth device will repeat LOW and HIGH.

- UART_CTS, UART_RTS

When the flow control is not used, non connection will not affect the operation of FB155BC.

5 Interface (Pin Connection)

5.1 Without Flow Control

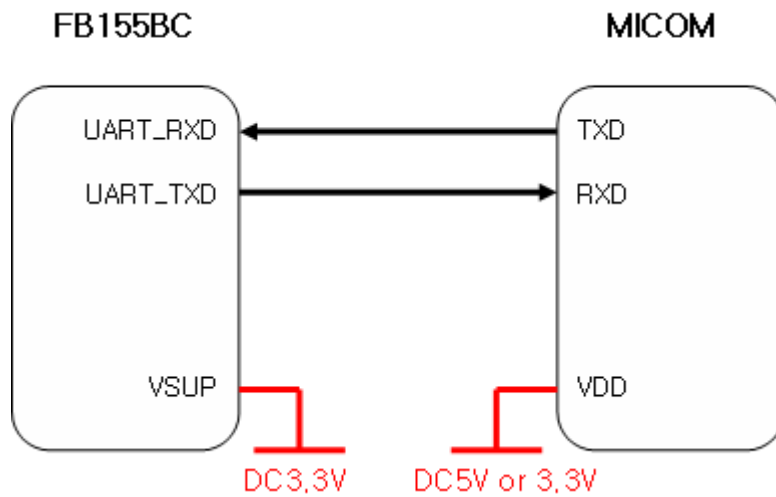

<Figure 5-1 : Pin Connection without Flow Control>

5.2 With Flow Control

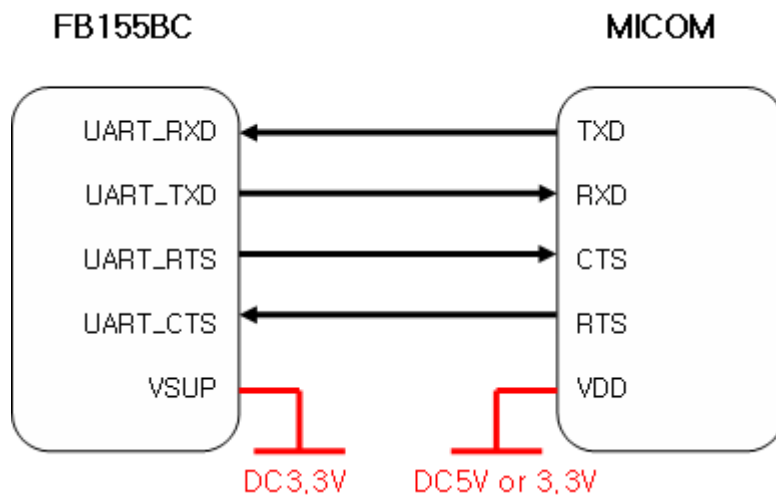

<Figure 5-2 : Pin Connection Diagram with Flow Control>

6 PC Interface Board (Jig Board)

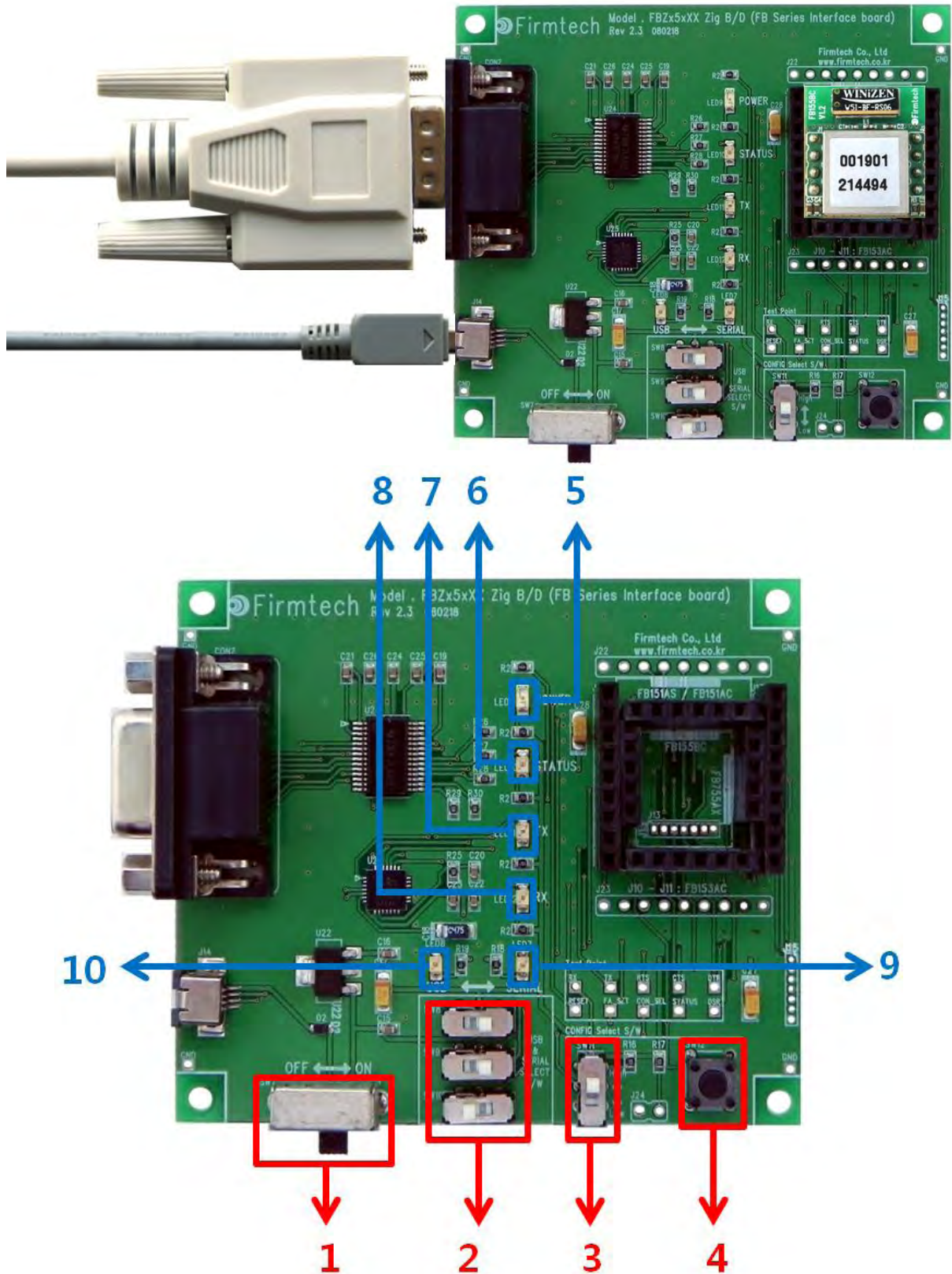

<Figure 6-1 FB155BC Interface Board(Jig Board)>

No.	Title	Description
1	Power ON/OFF Switch	ON/OFF the electric power of interface board.
2	USB/RS232 Interface Selection Switch	The switch for selection of communication in USB/RS232 (The 3 switches shall be set in same direction.)
3	PC Configuration/Operation Selection Switch	Not is use
4	FASET Switch	<p>The switch for changing the environment setting value of FB755 to the factory setting value.</p> <p>The procedures to make the FASET are as followings.</p> <ol style="list-style-type: none"> 1. Power ON 2. Press the FASET switch more than 2 seconds.
5	POWER LED	LED to check the power supply condition
6	STATUS LED	LED to check the action of FB755
7	TX LED	LED to check the data output condition of FB755
8	RX LED	LED to check the data input condition of FB755
9	SERIAL INTERFACE LED	LED to check whether the communication interface is RS-232
10	USB INTERFACE LED	LED to check whether the communication interface is USB

<Table 6-1 Interface Board Description>

7 Performance of Products

No.	Part	Specification	
1	Bluetooth Spec.	Bluetooth Specification 2.1 Support	
2	Communication distance	10 M	
3	Frequency Range	2402 ~ 2480MHz ISM Band	
4	Sensitivity	-83dBm (Typical)	
5	Transmit Power	4dBm(Typical)	
6	Size	18 x 20 mm	
7	Support Bluetooth Profile	SPP (Serial Port Profile)	
8	Input Power	3.3V	
9	Current Consumption	48 mA (Max)	
10	Temperature	Operating	-10°C ~ 50°C
		Limit Operating	-35°C ~ 55°C
11	Communication Speed	1,200bps – 230,400bps	
12	Antenna	Chip Antenna	
13	Interface	UART (TTL Level)	
14	Flow Control	RTS, CTS support	

<Table 7-1 FB155BC Performance>

8 Current Consumption

Status		Current Consumption (mA)		
		MIN	MAX	AVG
Standby		0	3	1
Inquiry scan & Page scan (Slave)		0	48	22
Page scan (Slave)		0	12	1
Inquiry (Master)		39	45	42
Connected	Slave	18	24	21
	Master	0	9	4
Data Transmission	Slave	24	30	28
	Master	18	27	21
Data Reception	Slave	21	33	26
	Master	21	33	27
Data Transmission/Reception	Slave	27	33	29
	Master	21	33	28
Power save	Slave	0	6	1
	Master	0	9	2

<Table 8-1 Current Consumption>

TEST CONDITIONS

Baud Rate : 9600 bps, Input Voltage : DC 5V

The power consumption will change depending on transmission speed and volume of data.

9 Preliminary Product Components

The preliminary value of product is set as on the <Table 9-1>.

Please be sure of basic set value and so on before using the product.

Type	Set Value
Device Name	FB155vx.x.x
Pin Code (Pass key)	BTWIN
Uart (baud rate-data bit-parity bit-stop bit)	9600-8-N-1
ROLE	SLAVE
Connection Mode	MODE4 (AT command)
Debug Char	0x02

<Table 9-1 Preliminary Configuration Setting Value for FB155BC>

To change the configuration set value of FB155BC, connect FB155BC to the PC using the PC Interface board then, you may change using the PC software (such as Window Hyper Terminal, FIRMTECH's PC configuration program). With MICOM, you may change the set value by using AT command.

Note :

For details on the setting change, please refer to 10 How to complete PC Configuration.

10 Connecting the wireless section of Bluetooth

In order for Bluetooth devices to transmit data to each other, the wireless section of Bluetooth should be connected to each other. To connect the wireless section, you should set each role for each device, one for a **MASTER**, another for a **SLAVE**. It takes about 1~10 sec that a Master is connected to a Slave.

The connection can be done in use of AT command or connection can be set in use of connection WIZARD because the initial connection mode of FB155BC is MODE4 (AT Command).

The following contents will be processed under the assumption that the FB755AC & FB755AS are connected to the interface Board (Jig Board).

※ We will use 2 FB155BC and MS Windows in describing procedures.

10.1 Connecting with Connection WIZARD

※ The connection WIZARD can not be used if the DEBUG Char is set to 0x00. Please refer to the details of environment setting in Appendix A for further details.

- (1) Connect the interface board of the first FB155BC to the serial port of PC and switch ON.
- (2) Execute C-Wizard Program.

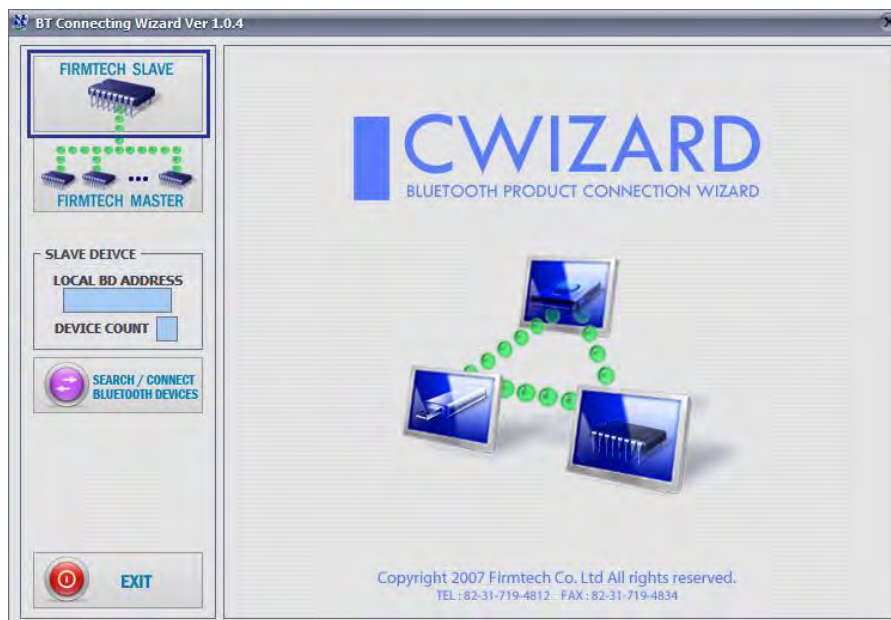

<Figure 10-1 Connection Wizard Step 1>

- (3) Click FIRMTECH SLAVE Set-up button (<Figure 10-1> Blue borders)

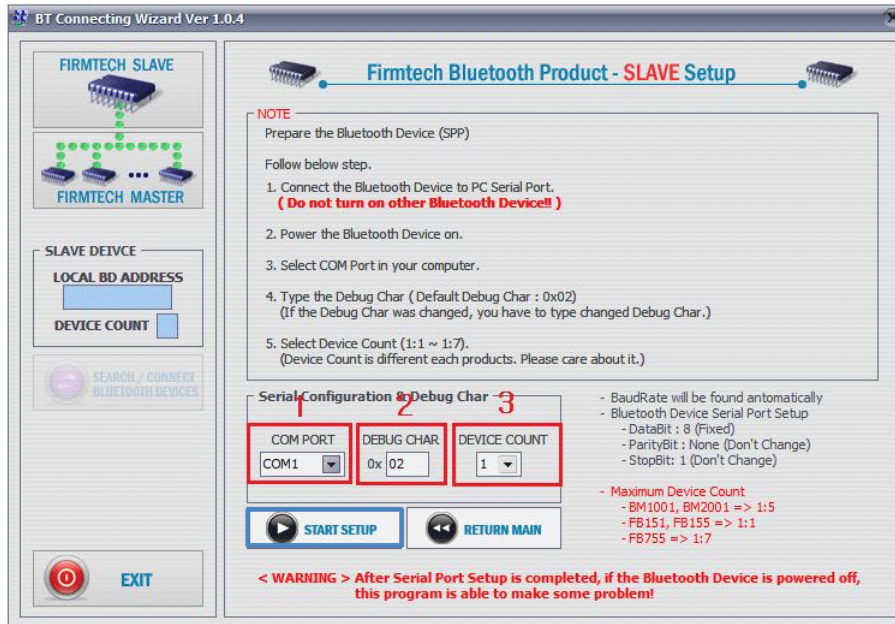

- 1 COM PORT** : Select Serial port of PC connected a product.
- 2 DEBUG CHAR** : Default is 0x02. (Refer to the appendix A about PC Configuration)
- 3 DEVICE COUNT** : Select number of devices to be connected. (Default 1)

<Figure 10-2 Connection Wizard Step 2>

- (4) Click the Set-up Start Button(<Figure 10-2> Blue borders) after setting each values in blanks (<Figure 10-2> Red borders **N.1 - Com Port connected to FB155BC, N.2 - 0x02, N.3 - 1**)

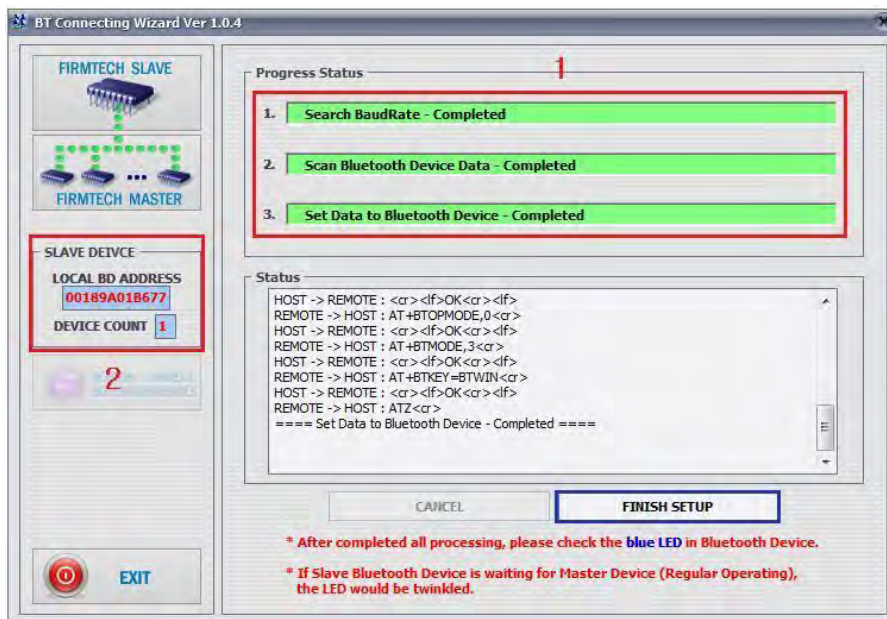

- 1 Procedures**: procedures of Device Set-up.
- 2 SLAVE Device value**: It shows values if the SLAVE Set-up is completed (optional)

<Figure 10-3 Connection Wizard Step 3>

- (5) Status Display of Procedures(<Figure 10-3>N. 1 red borders) turns red into green after Set-up is completed. Click the OK button if the blank of SLAVE Device Value is filled. (<Figure 10-3>N. 2 red borders)
- (6) Check the blinking of status LED on interface board.
- (7) Remove the interface board of the 1st FB155BC from the serial port of PC. (On the state of power ON)
- (8) Connect the interface board of the second FB155BC to the serial port of PC and switch ON.

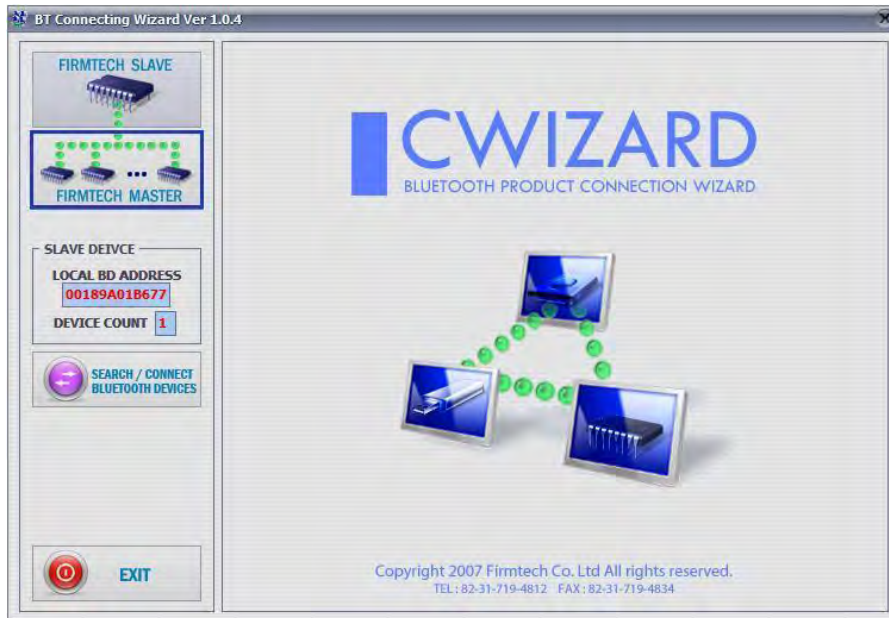

<Figure 10-4 Connection Wizard Step 4>

- (9) Click the FIRMTECH MASTER Set-up (<Figure 10-4> Blue borders) Button

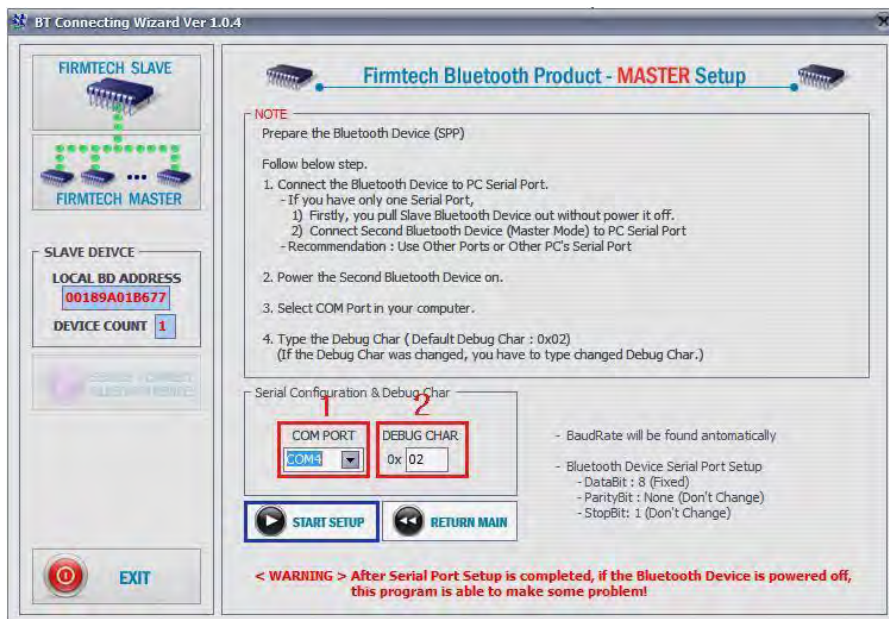

1 COM PORT : Select the Serial port of PC connected a product

2 DEBUG CHAR : Default is 0x02. (Refer to the appendix A about PC Configuration)

<Figure 10-5 Connection Wizard Step 5>

(10) Click Set-up Start (<Figure 10-5> blue borders) button after setting each value (<Figure 10-5> red borders **N.1 - Com Port connected to FB755AX, N.2 - 0x02**) in blanks.

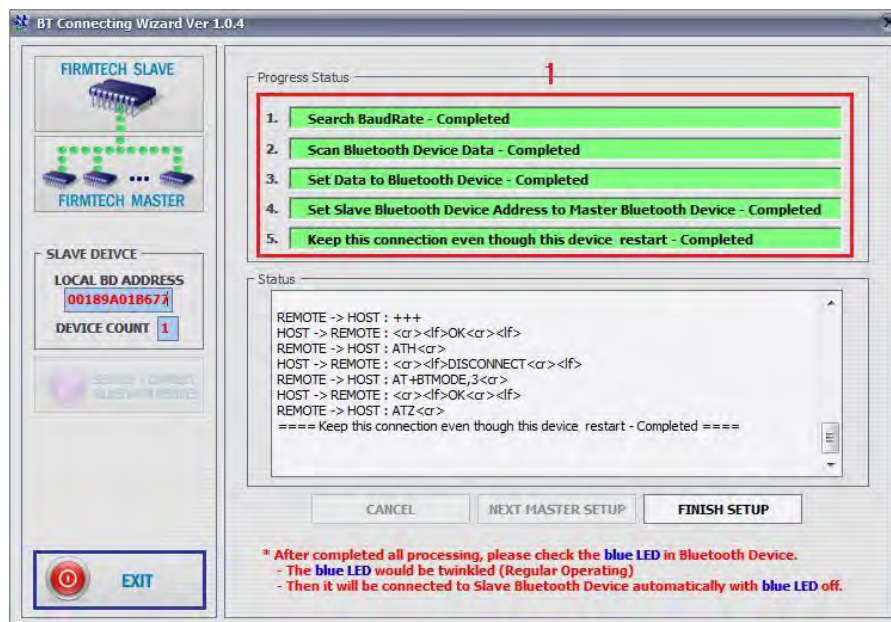

<Figure 10-6 Connection Wizard Step 6>

(11) If the Status Display of Procedures (<Figure 10-6> N.1 red borders) turns red into green, Connection Set-up is completed. With Clicking the End button(<Figure 10-6> Blue borders), finish the C-Wizard

10.2 Connection with AT commands

The serial communication program is necessary to connect with AT commands.

The setting is available using the hyper terminal offered by Windows and refer to the following "11.2.1 Execution of hyper terminal" to set hyper terminal.

Refer to the "4. How to use AT commands" of "Appendix B – AT Command Language with Detailed Description and Usage" to use the AT command.

11 How to complete PC Configuration?

The following PC Configuration shall be explained on the assumption that FB155BC is connected with PC Interface Board(Jig board). If it is connected to MICOM, then you can change the set value by using AT command language with reference to Attachment AT command language.

Components for PC Configuration

- FB155BC module
- PC Interface Kit

The PC Configuration could be processed with two significant ways.

First one is to use Config tool provided by FIRMTECH Co., Ltd.

Second one is to use serial communication program (Hyper Terminal, minicom) providing OS.

The respective way of setting is as follows.

11.1 PC Configuration using BTConfig tool

- (1) Connect FB155BC to PC Interface Board, then connect to COM port(Serial port) of PC.
- (2) Switch on the PC interface board in pressing the FASET button (The 4th switch in <Fig. 6-1>)

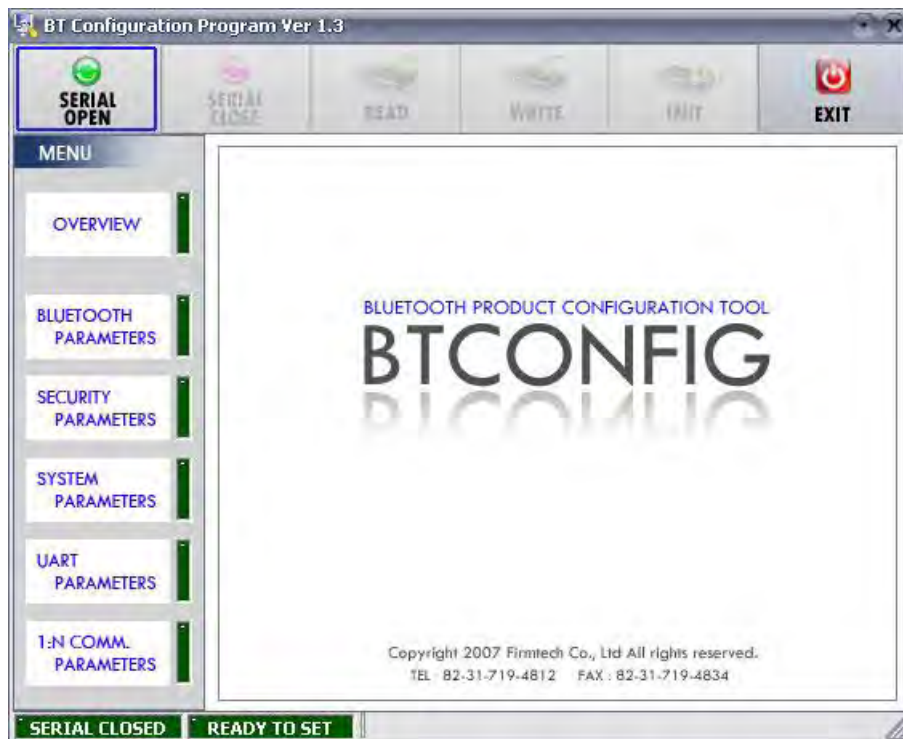

<Figure 11-1 BTConfig tool initialization>

- (3) Execute BTConfig tool after connect FB155BC to serial port of PC.
- (4) Click "SERIAL OPEN" button. (<Figure 11-1> blue borders)

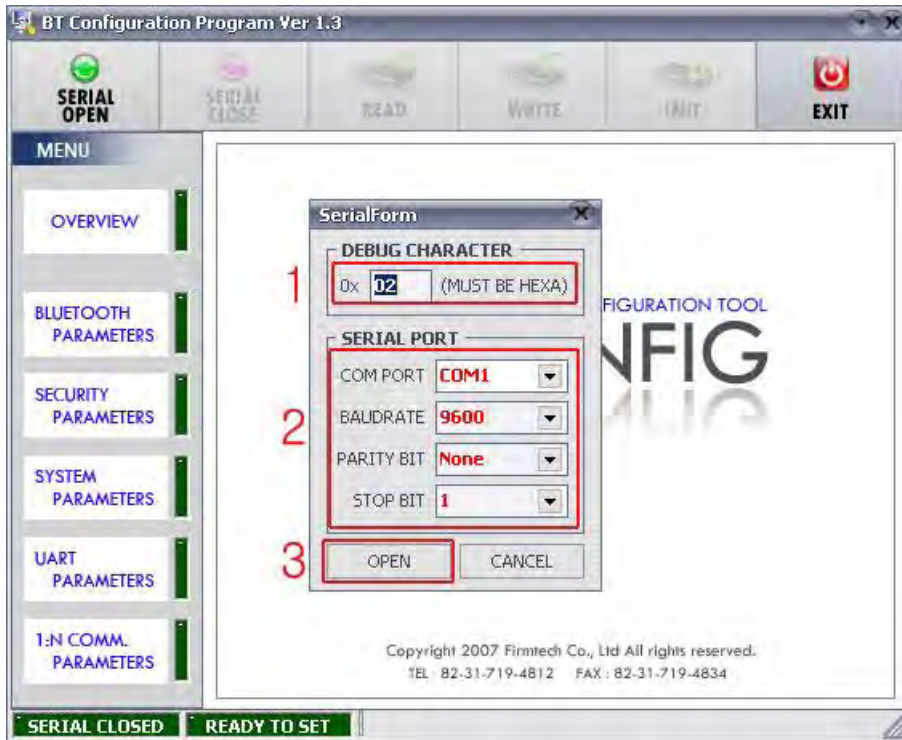

1 DEBUG CHARACTER : Default is 0x02. (refer to the appendix A about PC Configuration)

2 SERIAL PORT : COM PORT proper port, BAUDRATE **9600**, PARITY BIT **None**, STOP BIT **1**

<Figure 11-2 BTConfig tool Serial connection>

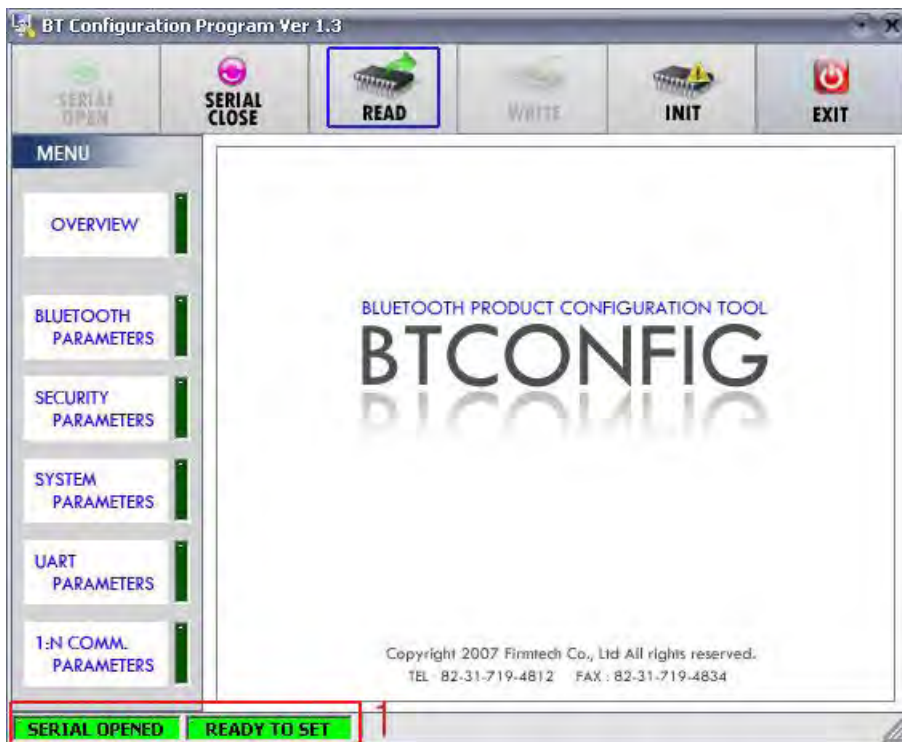

1 SERIAL OPENED, READ TO SET : BTConfig tool and communication status of products.

<Figure 11-3 BTconfig tool connection>

- (5) If the <Figure 11-2> comes up, set each blank (Red borders N.1~2) to (COM PORT – **Port connected to FB100AS**, BAUDRATE – **9600**, PARITY BIT – **None**, STOP BIT – **1**). After the set-up, click the OPEN button (Red borders N.3), then Serial Connection and Ready To Set (Red borders N.1) parts become green as shown on <Figure 11-3>
If they don't become green, check the COM PORT and execute BTConfig tool once again.
- (6) If click the READ button (blue borders) as shown on <Figure 11-3> after BTConfig tool is connected to products, MENU Buttons (<Figure 11-4> red borders N.1) are activated.

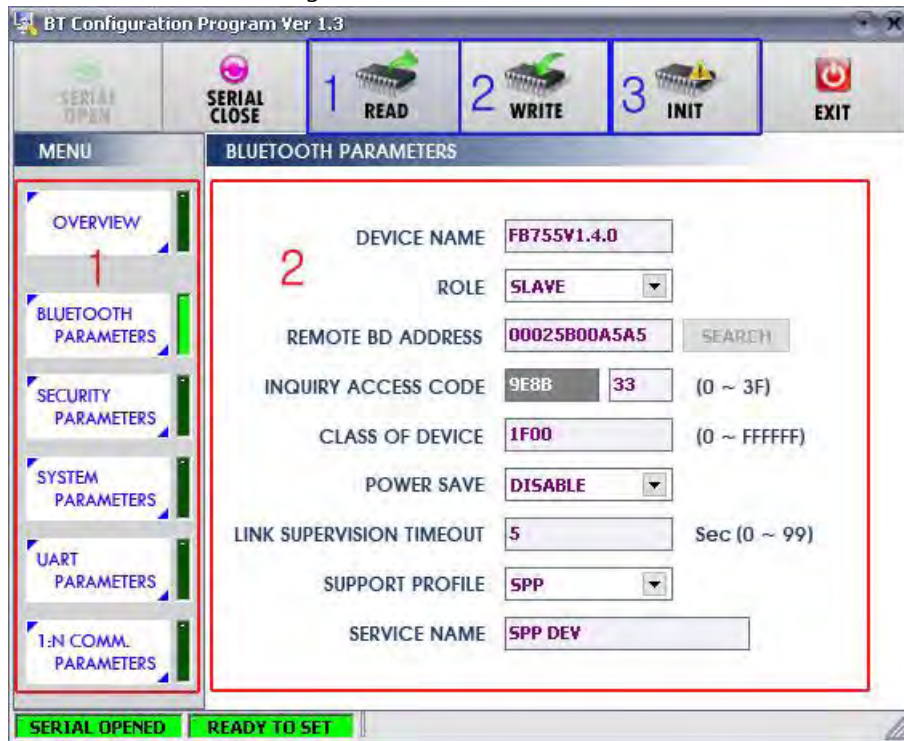

1 BLUETOOTH PARAMETERS: Set-up Group Button

2 Set-up window: change Set-up Groups and values

1 READ button: read set values. (READ should be done after BTConfig tool is connected to products at the very first initialization.)

2 WRITE button: Save set values. (Serial port is automatically completed after saving.)

3 INIT button: Reset all the set values to Factory fix points.

<Figure 11-4 BTConfig tool Set-up>

- (7) If you select any PARAMETERS(<Figure 11-4> red borders N.1), the window for Value Check and Set-up comes up on the right
- (8) Save the set values by clicking the WRITE button after Set-up completed.

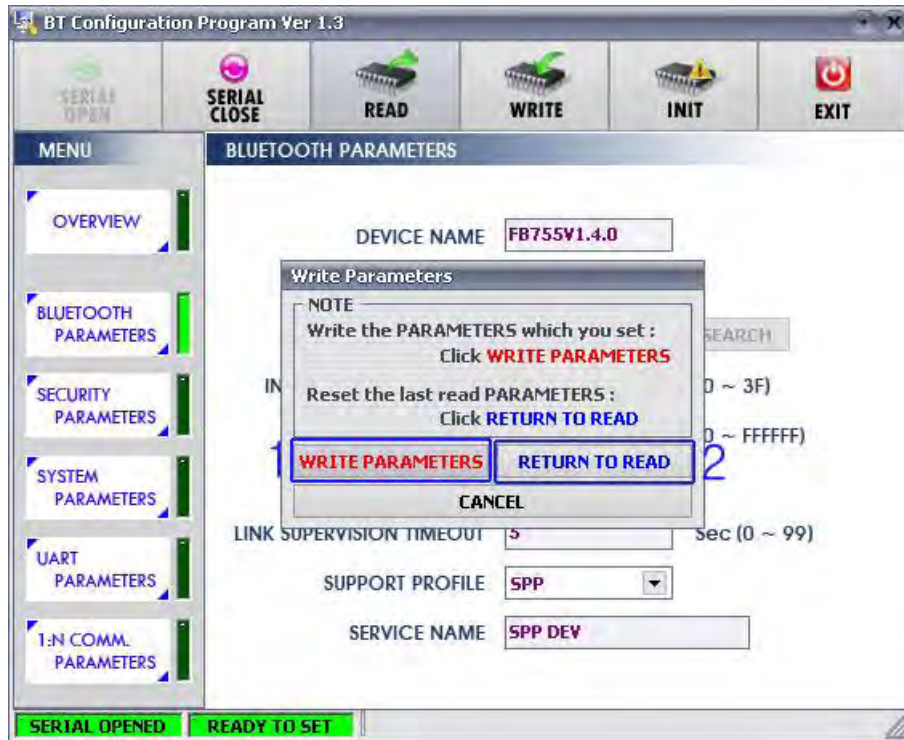

1 WRITE PARAMETERS: Save the currently set values.

2 RETURN TO READ: Set to the initial value.

<Figure 11-5 BTConfig tool WRITE>

Note :

Please refer to the appendix A of PC Configuration for the detailed description.

11.2 PC Configuration using Serial Communication (Hyper Terminal) Program

11.2.1 To Execute Hyper Terminal

To set up PC Configuration using Hyper Terminal, following procedures shall be performed prior to the power is being supplied after the FB755AX is connected to the PC.

To set up PC Configuration, the Serial Communication Program is required. We will use Hyper Terminal in describing the procedures.



<Figure 11-6 Hyper Terminal Set up Window 1>

- (1) Execute in the order of **[start]→[All Programs]→[Accessories]→[Communications]→[Hyper Terminal]**, then connection window will appear on which enter appropriate name and click.



<Figure 11-7 Hyper Terminal Set up Window 2>

- (2) When the <Figure 11-7> comes up, select the COM port connected to FB155BC, and clicks the OK button.

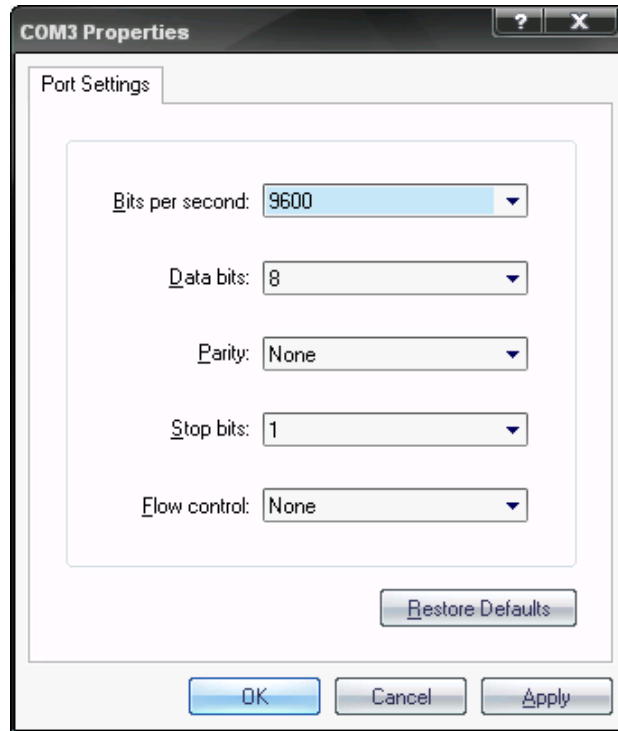

<Figure 11-8 Hyper Terminal Set up Window 3>

- (3) When Registration Information Window comes up as on <Figure 11-8>, select **Bit per second : 9600, Data bit : 8, Parity : none, Stop bit : 1, Flow control : none**, which will execute Hyper Terminal.

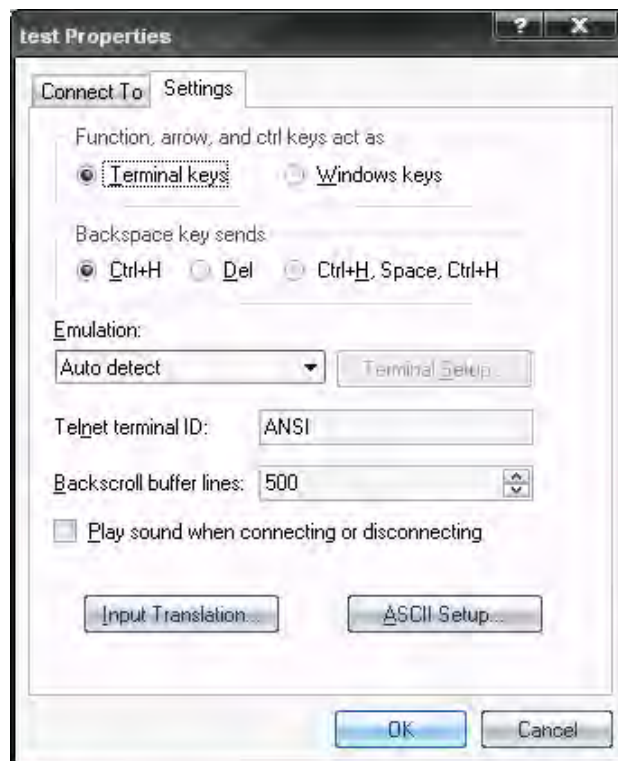

<Figure 11-9 Hyper Terminal Set Up Window 4>

- (4) Basically, the Hyper Terminal does not show the entered character. To make sure of the entered character, select **[File]→[Properties]** on the Menu, then registration information window will appear shown as on <Figure 12-9>, click the ASCII Setup button.

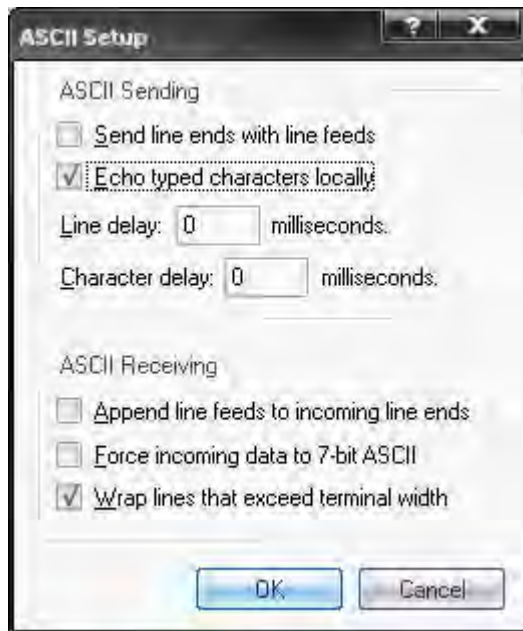

<Figure 11-10 Hyper Terminal Set Up Window 5>

- (5) As shown on <Figure 11-10>, Check **“Echo typed characters locally”** and come out pressing the acknowledge button. Now the Hyper Terminal program setting procedure is completed to use PC Configuration.
- (6) If the power is on **in pressing the FASET button (The 4th switch in <Fig. 6-1>)** on interface board, the menu like the <Fig. 11-11> is printed on the hyper terminal.

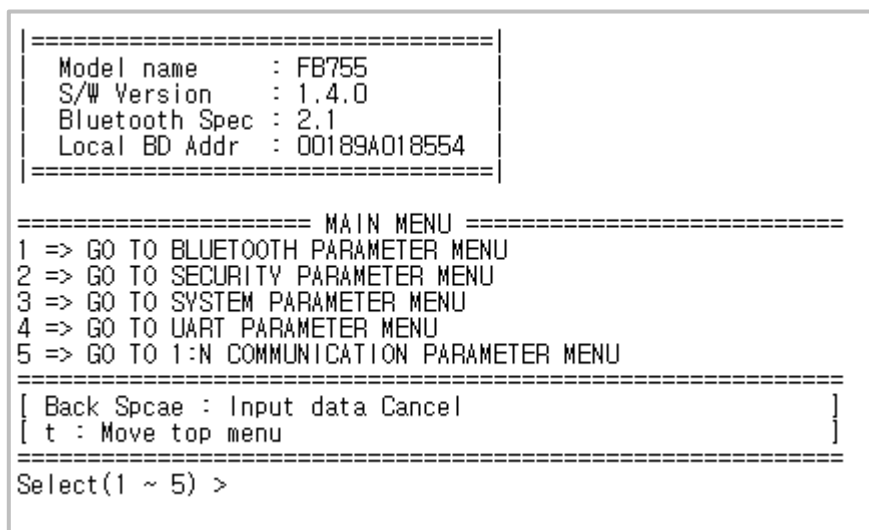

<Figure 11-11 Pc Configuration Menu>

11.2.2 How to Use PC Configuration Menu

The user may select the menu to change by selecting the given number in front of the left end menu.
For example : To change "GO TO BLUETOOTH PARAMETER MENU", enter : **[1]→[Enter]**

Note :

At <Figure 11-11> condition, Pressing Reset button for more than 2 seconds will reset all the configured values to the initial status (factory preset status).

Following is the order to use the menu.

- (1) The execution will only be executed by pressing the "Enter" key.
- (2) The small character "t" will always move to be positioned at upper side of the menu.
- (3) To move menu, use the number in the end of left side. Please be sure to "Enter" key upon completion of input.
- (4) "←" key is used to delete the entered character currently.
- (5) If the entered character is unreadable or is not supported at the appropriate menu, "Retry >" message will be output.
- (6) If the input message is more than 12 characters, "Overflow buffer" message will be output and then "Retry >" message appeared as well.

Note :

Please refer to Appendix A PC Configuration for the detailed description on the configuration value.

14 Approval Information

14.1 KCC

14.2 FCC compliance Information

FCC Information to User

This equipment has been tested and found to comply with the limits for a Class B digital device, pursuant to Part 15 of the FCC Rules. These limits are designed to provide reasonable protection against harmful interference in a residential installation. This equipment generates, uses and can radiate radio frequency energy and, if not installed and used in accordance with the instructions, may cause harmful interference to radio communications. However, there is no guarantee that interference will not occur in a particular installation. If this equipment does cause harmful interference to radio or television reception, which can be determined by turning the equipment off and on, the user is encouraged to try to correct the interference by one of the following measures:

- Reorient or relocate the receiving antenna.
- Increase the separation between the equipment and receiver.
- Connect the equipment into an outlet on a circuit different from that to which the receiver is connected.
- Consult the dealer or an experienced radio/TV technician for help.

Caution

Modifications not expressly approved by the party responsible for compliance could void the user's authority to operate the equipment.

FCC Compliance Information : This device complies with Part 15 of the FCC Rules. Operation is subject to the following two conditions: (1) This device may not cause harmful interference, and (2) this device must accept any interference received, including interference that may cause undesired operation FB155BC

Including interference that may cause undesired operation.

Modifications not expressly approved by the manufacturer could void the user's authority

To operated the equipment under FCC rules.

To satisfy FCC exterior labeling requirements, the following text must be placed on the exterior of the end product.

Contains Transmitter Module FCC ID : U8D-FB155BC

CAUTION : This device and its antenna(s) must not be co-located or operated in conjunction with any other antenna or transmitter. End users cannot modify this transmitter device. Any unauthorized modification could void the user's authority to operate this device.

This device is intended only for OEM integrators under the following conditions:

- 1) The transmitter module may not be co-located with any other transmitter or antenna,
- 2) OEM shall not supply any tool or info to the end-user regarding to Regulatory Domain change.

As long as 2 conditions above are met, further transmitter test will not be required. However, the OEM integrator is still responsible for testing their end-product for any additional compliance requirements required with this module installed (for example, digital device emissions, PC peripheral requirements, etc.).

IMPORTANT NOTE: In the event that these conditions can not be met (for example certain laptop configurations or co-location with another transmitter), then the FCC authorization is no longer considered valid and the FCC ID can not be used on the final product. In these circumstances, the OEM integrator will be responsible for re-evaluating the end product (including the transmitter) and obtaining a separate FCC authorization.

Manual Information To the End User

The OEM integrator has to be aware not to provide information to the end user regarding how to install or remove this RF module in the user's manual of the end product which integrates this module. The end user manual shall include all required regulatory information/warning as show in this manual.

IMPORTANT NOTE:

FCC RF Radiation Exposure Statement:

This equipment complies with FCC RF radiation exposure limits set forth for an uncontrolled environment. This equipment should be installed and operated with a minimum distance of 20 centimeters between the radiator and your body. This transmitter must not be co-located or operating in conjunction with any other antenna or transmitter.

14.3 CE

Hereby, FIRMTECH Co., Ltd, declares that this FB155BC is in compliance with the essential requirements and other relevant provisions of directive 1999/5/EC.

14 Approval Information