

Zigbee Embedded Module

FZ750BS/FZ750BC

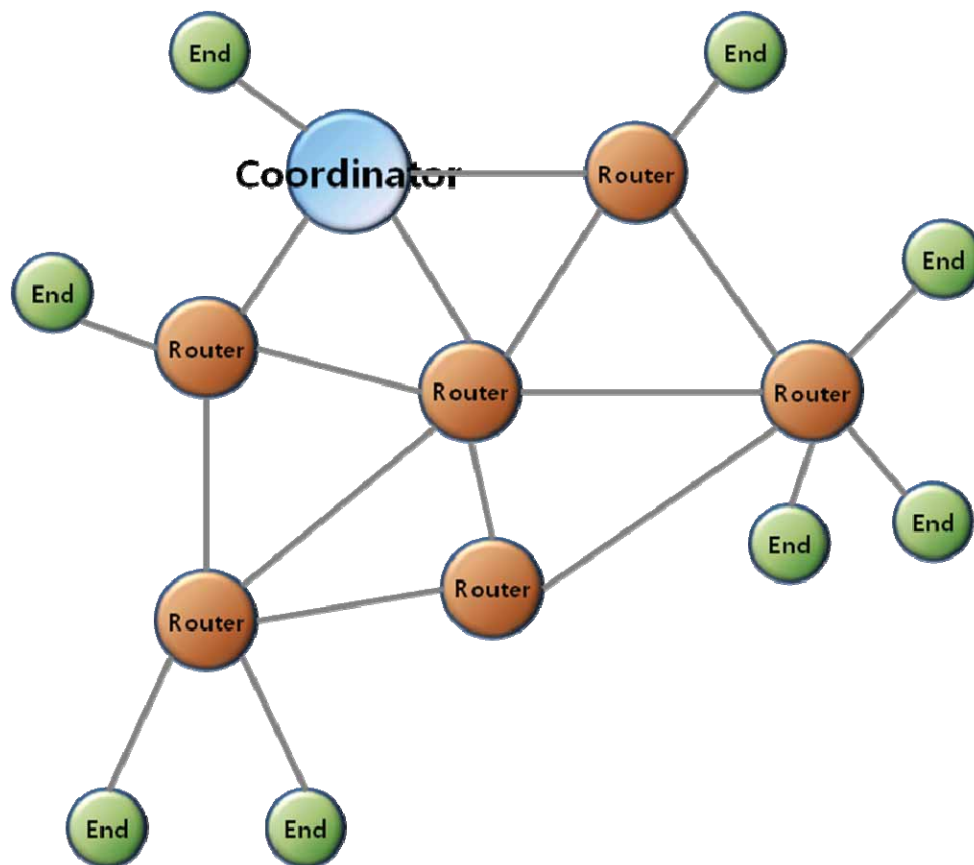

ABOUT FZ750BS/FZ750BC

Zigbee 2006 Support

20PINs Header type

Chip or CMP Antenna

AT Command provided

(C) Copyright FIRMTECH Co., Ltd. 2005

All rights reserved

The products and operation descriptions contained herein shall be protected by copyright law.

Any part or whole of products or operation description shall not be copied, reproduced, translated, nor transformed into readable form by electronic device or machines, without prior consent in writing by FIRMTECH Co., Ltd.

There might be some misprinting or technical faults in the products and operation description which are subject to change without prior notice.

FCC Information to User

This equipment has been tested and found to comply with the limits for a Class B digital device, pursuant to Part 15 of the FCC Rules. These limits are designed to provide reasonable protection against harmful interference in a residential installation. This equipment generates, uses and can radiate radio frequency energy and, if not installed and used in accordance with the instructions, may cause harmful interference to radio communications. However, there is no guarantee that interference will not occur in a particular installation. If this equipment does cause harmful interference to radio or television reception, which can be determined by turning the equipment off and on, the user is encouraged to try to correct the interference by one of the following measures:

- Reorient or relocate the receiving antenna.
- Increase the separation between the equipment and receiver.
- Connect the equipment into an outlet on a circuit different from that to which the receiver is connected.
- Consult the dealer or an experienced radio/TV technician for help.

Caution

Modifications not expressly approved by the party responsible for compliance could void the user's authority to operate the equipment.

FCC Compliance Information : This device complies with Part 15 of the FCC Rules. Operation is subject to the following two conditions: (1) This device may not cause harmful interference, and (2) this device must accept any interference received, including interference that may cause undesired operation

FIRMTECH Co., Ltd. 2005

Room B-606, Ssangyong IT Twin Tower, Sangdaewon-dong, 442-5, Jungwon-gu, Seongnam-si,
Gyeonggi-do, Korea 462-120

Homepage : www.firmtech.co.kr

Marketing Inquiry : contact@firmtech.co.kr

Technical Support Inquiry : techsupport@firmtech.co.kr

Tel : 82-31-719-4812

Fax : 82-31-719-4834

What is zigbee?

1. Features of Bluetooth

1) Objectives of Zigbee : To realize Personal Wireless Communication for short distance and slow speed with Low Power consumption and Low Cost, which is based on IEEE 802.15.4 Standard.

2) Frequency in Use : To use ISM(Industrial, Scientific, Medical) Band which does not require any permission to use.

– 2.400 ~ 2.4835 GHz: 15 channels in all nations (No.11 ~25 channel)

3) Transmission Rate

– 2.400 ~ 2.4835 GHz: 250Kbps

4) Tx Power and working distance

– 1mW (0dBm) Inside: 30m, Outside: 100m

– Over 100m with 1mW

– Tx Power is subject to change depending on manufacturers.

5) Configuration

– Zigbee device is configured of Coordinator, Router and End Device.

– Coordinator configures Network

– Router expands Network

– End device participates in Network

– With 64bit address, can configure a maximum of 65536 Networks connected

6) Reliability

– Supports Network level and Device level using Authentication–Network Key and Link Key.

– Supports encrypted packet transmission using 128bit AES Encryption.

– Guarantees data reliability on the application layer using ACK option in APS Packet

– Guarantees data reliability on the physical layer using ACK option in MAC Packet.

Products overview

FZ750BS/FZ750BC can configure Zigbee network with low power consumption and low capacity by using Zigbee stack.

< Major features of FZ750BS/FZ750BC >

1. Zigbee 2006 support
2. Mesh network support
3. Easily applicable to the product with 20Pins Header type
4. Easy to input data with data Input ports, such as UART, ADC, KEY and GPIO port.
5. Supports AT command, and control Devices by using the AT command.
6. Supports Low power consumption mode of End Device
 - Low power consumption mode 1: Use 25uA
 - Low power consumption mode 2: Use 2uA
 - Low power consumption mode 3: Use 1uA
7. Can check whether data is successfully transmitted or not by using ACK option.
8. By using Key Option, can obtain new Zigbee Network Routes so that data re-transmission is possible even if finding the communication route is failed for the first time.
9. Use 2.400 ~ 2.4835 GHz(ISM Band) 15 channels (No.11 ~25 channel)
 - 11 (0x0B): 2405MHZ, 12 (0x0C): 2410MHZ, 13 (0x0D): 2415MHZ,
 - 14 (0x0E): 2420MHZ, 15 (0x0F): 2425MHZ, 16 (0x10): 2430MHZ,
 - 17 (0x11): 2435MHZ, 18 (0x12): 2440MHZ, 19 (0x13): 2445MHZ,
 - 20 (0x14): 2450MHZ, 21 (0x15): 2455MHZ, 22 (0x16): 2460MHZ,
 - 23 (0x17): 2465MHZ, 24 (0x18): 2470MHZ, 25 (0x19): 2475MHZ,

※ We request the new users of FZ750BS/FZ750BC to read the information on this description carefully before they start to use the products.

※ Please consult Firmtech.co., Ltd if you want to configure Zigbee Network using more than 30 devices of FZ750BS/FZ750BC

■ List of contents

1. PRELIMINARY USAGE OF PRODUCT.....	12
1-1. PRODUCT COMPONENTS.....	12
1-1-1. FZ750BS/FZ750BC.....	12
1-1-2. PC Interface Board.....	12
1-2. FZ750BS/FZ750BC OVERVIEW.....	13
1-3. OPERATION OF FZ750BS/FZ750BC AND INTERFACE BOARDS.....	19
1-4. FEATURES OF END DEVICE.....	28
2. PRODUCT PERFORMANCE.....	34
2-1. FZ750BS/FZ750BC PERFORMANCE.....	34
3. CURRENT CONSUMPTION.....	34
3-1. FZ750BS/FZ750BC CURRENT CONSUMPTION.....	34
4. PRODUCT APPEARANCE.....	35
4-1. FZ750BS/FZ750BC IMAGE & DIMENSION.....	35
4-2. FZ750BS/FZ750BC PIN ASSIGN.....	37
4-3. FZ750BS/FZ750BC PIN DESCRIPTION.....	38
4-3-1. ADC port.....	38
4-3-2. TX port.....	38
4-3-3. RX port.....	38
4-3-4. ISP port.....	38
4-3-5. RESET port.....	38
4-3-6. STATUS port.....	39
4-3-7. ERROR port.....	39
4-3-8. OK port.....	40
4-3-9. KEY port.....	40
4-3-10. GND port.....	41
4-3-11. VCC port.....	41
4-3-12. GPIO port.....	41
5. INTERFACE (PIN CONNECTION).....	42
5-1. CONNECTION BETWEEN A FZ750BS/FZ750BC AND AN INTERFACE BOARD.....	42
5-2. PIN CONNECTION BETWEEN A FZ750BS/FZ750BC AND A MICOM.....	42
5-3. CONNECTION BETWEEN A FZ750BS/FZ750BC AND A PC.....	43
5-4. PIN CONNECTION BETWEEN A GPIO PORT OF FZ750BS/FZ750BC AND MICOM (EXTENSION CONNECTION).....	44

5-5. PIN CONNECTION BETWEEN A GPIO PORT OF FZ750BS/FZ750BC AND AN INTERFACE BOARD (EXTENSION CONNECTION).....	45
6. SET VALUE OF PRODUCT.....	46
6-1. SET VALUE OF FZ750BS/FZ750BC	46
7. PC INTERFACE BOARD.....	47
7-1. INTERFACE BOARD DESCRIPTION	47
7-1-1. USB power input terminal & power on/off switch & reset switch	47
7-1-2. RS232 interface terminal	48
7-1-3. FZ750BS/FZ750BC connection connector.....	48
7-1-4. Control selection switch	49
7-1-5. KEY data Input Switch.....	51
7-1-6. ADC data Input Variable Resistance.....	51
7-1-7. GPIO selection switch.....	52
7-1-8. GPIO Input Switch & GPIO Output LED	53
7-1-9. RX / TX LED.....	54
7-1-10. STS / ERR / OK LED	54
7-1-11. ISP selection switch	55
7-1-12. Extension test port.....	55
(1) It is connected to KEY / ADC / GPIO port of FZ750BS/FZ750BC.	55
7-2. CHECK LISTS BEFORE MOUNTING FZ750BS/FZ750BC ON AN INTERFACE BOARD.	59
7-2-1. ISP selection switch	59
7-2-2. KEY / RTS selection switch	59
7-2-3. VR / SEN selection switch	59
7-2-4. GPIO selection switch.....	59
7-2-5. Power Input Switch.....	59
7-2-6. RS232 Connector	59
7-2-7. USB Power Connector	59
8. ZIGBEE NETWORK CONFIGURATION.....	60
8-1. SERIAL COMMUNICATION (HYPER TERMINAL) PROGRAM EXECUTE.....	60
8-2. SET-UP FZ750BS/FZ750BC DEVICE TYPE.....	62
8-2-1. FZ750BS/FZ750BC End Device Set-up	63
8-2-2. FZ750BS/FZ750BC Router Set-up	64
8-2-3. FZ750BS/FZ750BC Coordinator set-up.....	65
8-3. THE ZIGBEE NETWORK CONFIGURATION USING FZ750BS/FZ750BC.....	66
8-3-1. The Zigbee Network confiuration	66
8-3-2. Zigbee Network Extension	66

8-3-3. Zigbee Network Participation	67
9. FZ750BS/FZ750BC DATA TRANSMISSION.....	68
9-1. SET-UP TRANSMISSION DATA TYPE	69
9-1-1. UART set-up	69
9-1-2. ADC set-up	69
9-1-3. KEY set-up	70
9-1-4. COUNT set-up.....	72
9-1-5. GPIO Set-up	73
9-2. TARGET DEVICE SET-UP.....	75
9-2-1. Searching for an IEEE ADDRESS of FZ750BS/FZ750BC	75
9-2-2. Target device set-up	76
9-3. DATA TRANSMISSION.....	77
9-3-1. UART data transmission	77
9-3-2. KEY data transmission	78
9-3-3. ADC data transmission	80
9-3-4. COUNT data transmission.....	82
9-3-5. GPIO data transmission.....	82
10. FZ750BS/FZ750BC SET-UP USING GUI(SENBEE).....	87
10-1. SERIAL PORT CONNECTION	89
10-2. OVERVIEW.....	92
10-3. LOCAL CONFIGURATION	93
10-4. OUTPUT CONFIGURATION	94
10-5. OTHER CONFIGURATION.....	95
10-6. WRITE STATUS.....	96
10-7. INITIALIZE DEVICE.....	98
11. FZ750BS/FZ750BC MANAGEMENT TIP	99
11-1. FZ750BS/FZ750BC DEVICE TYPE SET-UP.....	99
11-2. ZIGBEE NETWORK CONFIGURATION	99
11-3. [SET-UP] TARGET DEVICE & DATA TRANSMISSION TYPE	100
11-4. START MESSAGE.....	103
11-5. DEBUG MESSAGE	105
11-6. RESET OPTION.....	107
11-7. HOW TO CONNECT FZ750BS/FZ750BC TO MAGNETIC SENSOR & SET-UP FOR OPERATION	108
12. AT-COMMAND.....	111
12-1. COMMAND CATEGORY	111
12-2. FUNCTION OF AT COMMAND	113

12-2-1. AT+SETEND	113
12-2-2. AT+SETROUTER	113
12-2-3. AT+SETCOORD	113
12-2-4. AT+SETADC1	113
12-2-5. AT+SETADC0	114
12-2-6. AT+SETKEY1	114
12-2-7. AT+SETKEY0	114
12-2-8. AT+SETCOUNT1	115
12-2-9. AT+SETCOUNT0	115
12-2-10. AT+SETTMR60	115
12-2-11. AT+SETTARGET1234567890123456	116
12-2-12. AT+SETDEVNAME123456789012	116
12-2-13. AT+SETBAUD9600	116
12-2-14. AT+SETCHANNEL0B	117
12-2-15. AT+SETRETRY3	117
12-2-16. AT+SETACK1	117
12-2-17. AT+SETACK0	118
12-2-18. AT+SETPMODE1	118
12-2-19. AT+SETSTAMSG1	118
12-2-20. AT+SETSTAMSG0	119
12-2-21. AT+SETDEBMSG1	119
12-2-22. AT+SETDEBMSG0	119
12-2-23. AT+SETTXPOWER00	120
12-2-24. AT+SETLQI1	120
Receive Sensitivity Output of Received data is set to be enabled by a command AT+SETLQI1 ..	120
12-2-25. AT+SETLQI0	120
12-2-26. AT+SETRESET1	120
12-2-27. AT+SETRESET0	121
12-2-28. AT+SETLPQUICK1	121
12-2-29. AT+SETLPQUICK0	121
12-2-30. AT+SETBATTERY1	121
12-2-31. AT+SETBATTERY0	122
12-2-32. AT+SETGPIO0	122
12-2-33. AT+SETGPIO1	122
12-2-34. AT+SETGPIO2	123
12-2-35. AT+GETPAN	123
12-2-36. AT+GETVER	123
12-2-37. AT+GETTMR	123

12-2-38. AT+GETACK	124
12-2-39. AT+GETKEY	124
12-2-40. AT+GETADC	124
12-2-41. AT+GETLQI	124
12-2-42. AT+GETBAUD	125
12-2-43. AT+GETLOCAL	125
12-2-44. AT+GETCOUNT	125
12-2-45. AT+GETRETRY	125
12-2-46. AT+GETPMODE	126
12-2-47. AT+GETTARGET	126
12-2-48. AT+GETPARENT	126
12-2-49. AT+GETSTAMSG	127
12-2-50. AT+GETDEBMSG	127
12-2-51. AT+GETCHANNEL	127
12-2-52. AT+GETTXPOWER	127
12-2-53. AT+GETDEVNAME	128
12-2-54. AT+GETRESET	128
12-2-55. AT+GETLPQUICK	128
12-2-56. AT+GETBATTERY	128
In case that the Input voltage of FZ750BS/FZ750BC is 2.6V, set value related the Input voltage is output to its target device by a command AT+GETBATTERY	128
12-2-57. AT+GETGPIO	129
12-2-58. AT+REQADDR	129
12-2-59. AT+REQEXTADDR1234	130
12-2-60. AT+REQNWKADDR1234567890123456	130
12-2-61. +++	131
12-2-62. AT	131
12-2-63. ATO	131
12-2-64. ATZ	132
12-2-65. AT&F	132

1. Preliminary usage of product

1-1. Product components

1-1-1. FZ750BS/FZ750BC

- FZ750BS/FZ750BC Zigbee Embedded Module
- On-board Chip or Helical Antenna (2.85 dBi Gain)

1-1-2. PC Interface Board

- Interface Board
- Serial Extension Cable
- USB Power Cable
- CD

※ If you find any of above components is defective, or not included in the package, please contact the seller you purchased.



< FZ750BC-Type 1set >

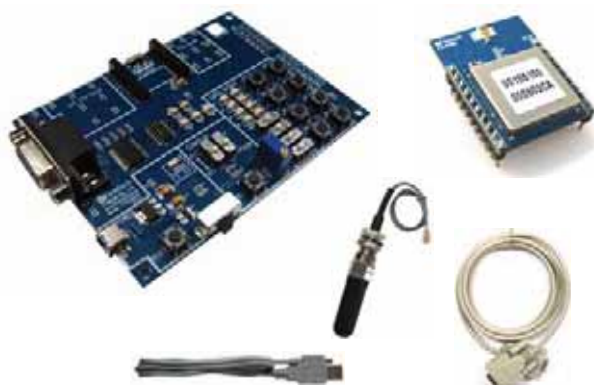

< FZ750BS-Type 1set >

1-2. FZ750BS/FZ750BC Overview

- (1) To configure the Zigbee network, set each device (FZ750BS/FZ750BC) to Coordinator, Router and End Device.

The initial factory set value of FZ750BS/FZ750BC is set to Router.



- (2) Do not use Broadcast accompanied by a lot of traffic in the Zigbee network unless it is vital to be used.

It is not recommended to make a lot of traffic in the Zigbee network because it causes lots of trouble when transmitting data and bothers to set the new route toward target devices.

- (3) Do not set short time for data transmission in the Zigbee Network. The more nodes the Zigbee Network has, the longer time for transmission time should be set.

Example.1) Zigbee Network Contribution using 10 FZ750BS/FZ750BCs

Set a time space to 2seconds for data transmission between FZ750BS/FZ750BCs.

(set 2sec minimally per 10 FZ750BS/FZ750BCs)

Example.2) Zigbee Network Contribution using 20 FZ750BS/FZ750BCs

Set a time space to 4seconds for data transmission between FZ750BS/FZ750BCs.

(set 2sec minimally per 10 FZ750BS/FZ750BCs*2=4sec)

It is not recommended to make a lot of traffic in the Zigbee Network.

(4) Coordinator and Router can configure child nodes up to 8

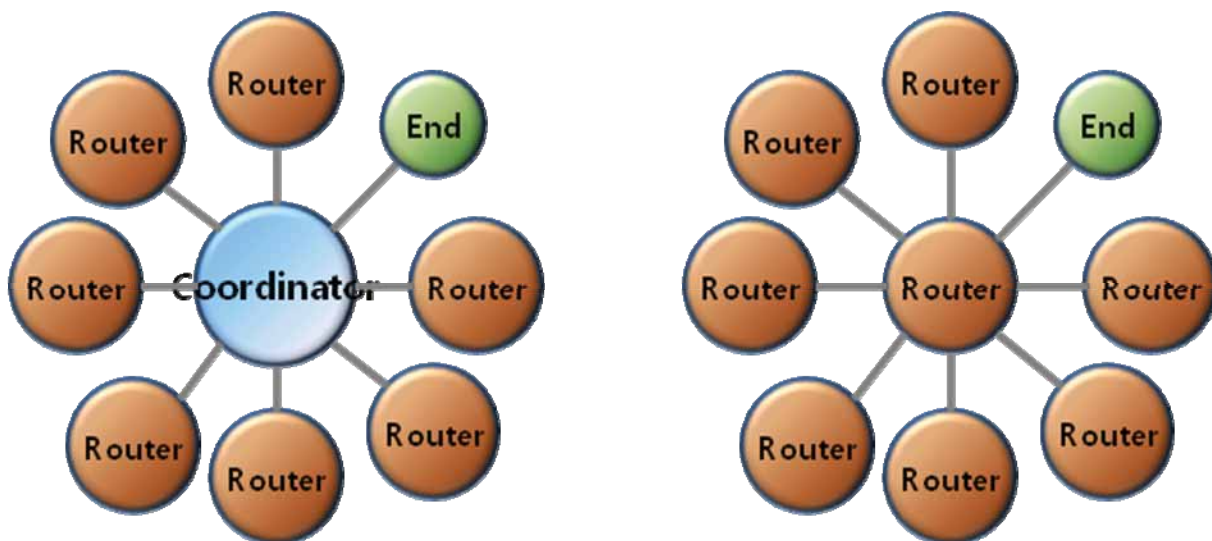

(5) **End Devices cannot configure Child nodes**

Setting FZ750BS/FZ750BC to End Devices should be prior to the Zigbee Network Configuration. If you want to change the device type of FZ750BS/FZ750BC from Router to End Device in the Zigbee Network, you had better re-configure the whole Zigbee Network in advance.

FZ750BS/FZ750BC can configure Child nodes after they are set to Routers and participated in the Zigbee Network. Also, other devices can participate in the Zigbee Network by setting the FZ750BS/FZ750BC set to Routers to their parent nodes, as well. If you change the FZ750BS/FZ750BC set to parent nodes to End Devices, the current End Devices cannot configure child nodes. In this situation, it is possibly can happen that other devices set the Routers to their parent nodes before the Routers are changed to End devices.

FZ750BS/FZ750BC supports mesh network, so you can expect the stable Zigbee Network. However, in order to make sure of proper Zigbee Network configuration, FZ750BS/FZ750BC of child nodes had better save FZ750BS/FZ750BCs set to Router (or coordinator) as their parent nodes

Thus, you had better set the type of each Device (especially End Device) before the Zigbee Network Configuration.

(6) FZ750BS/FZ750BC can configure the Zigbee Network up to 4 Depth.

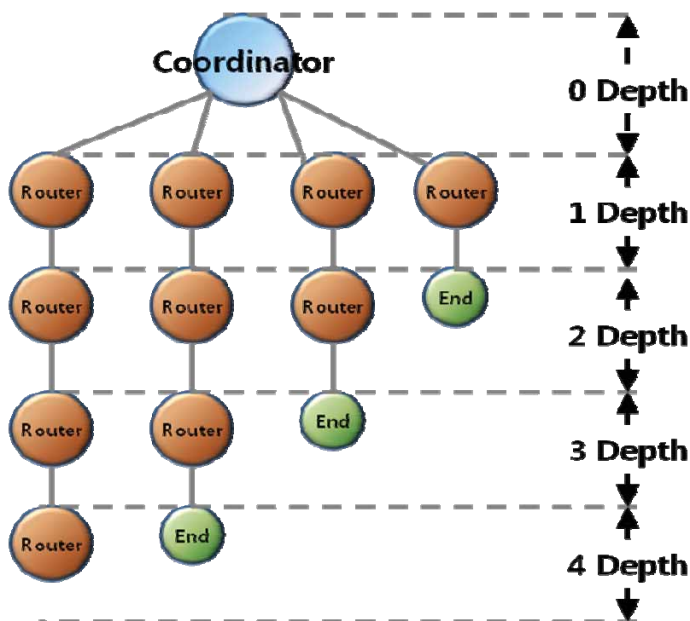

(7) FZ750BS/FZ750BC configures the Zigbee Network with one Coordinator.

(8) FZ750BS/FZ750BC can transmit data by multipath because it supports mesh network.

[Contribute the Zigbee Network which has multipath.](#)

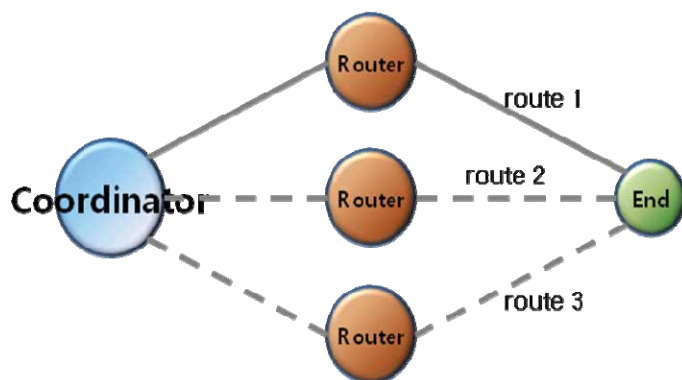

(9) FZ750BS/FZ750BC has UART port for Serial Input and Output. The UART port is connected to the RS-232 on interface boards.

If you input Serial data into FZ750BS/FZ750BC, It transmits the Serial data to its target device.

[If you input Serial data into FZ750BS/FZ750BC, other data is not transmitted. For example, if you input 1bit of Serial data in the middle of ADC data transmission once every 10seconds by FZ750BS/FZ750BC, the ADC data transmission stops until the Serial data transmission is completed. The FZ750BS/FZ750BC starts to transmit the ADA data again after the Serial data Transmission is finished.](#)

(10) FZ750BS/FZ750BC has ADC port for Analog signal Input. The ADC port is connected to variable resistance on an Interface board.

FZ750BS/FZ750BC reads ADC port every certain time and transmits ADC data to its target device.

(11) FZ750BS/FZ750BC has a KEY port for Digital signal Input. The KEY port is connected to KEY switch on an interface board.

If you input KEY data input FZ750BS/FZ750BC, it transmits the KEY data to its target device.

(12) FZ750BS/FZ750BC has GPIO port for Digital signal input and output.

If you use the GPIO for Input, It should be connected to GPIO switch on an interface board. It should be connected to GPIO LED on an interface board for Output.

If you input GPIO data into FZ750BS/FZ750BC, It transmits the GPIO data to its target device.

(13) FZ750BS/FZ750BC has STATUS port for showing the status of the Device.

The STATUS port is connected to STATUS LED on an interface board.

OK port of FZ750BS/FZ750BC shows that the status of FZ750BS/FZ750BC is okay, and it is connected to OK LED on an interface board.

ERROR port of FZ750BS/FZ750BC shows the status of FZ750BS/FZ750BC is error, and it is connected to ERROR LED on an interface board.

(14) **When you transmit data by using FZ750BS/FZ750BC, you need to check the result value for the transmission through the OK/ERROR port.**

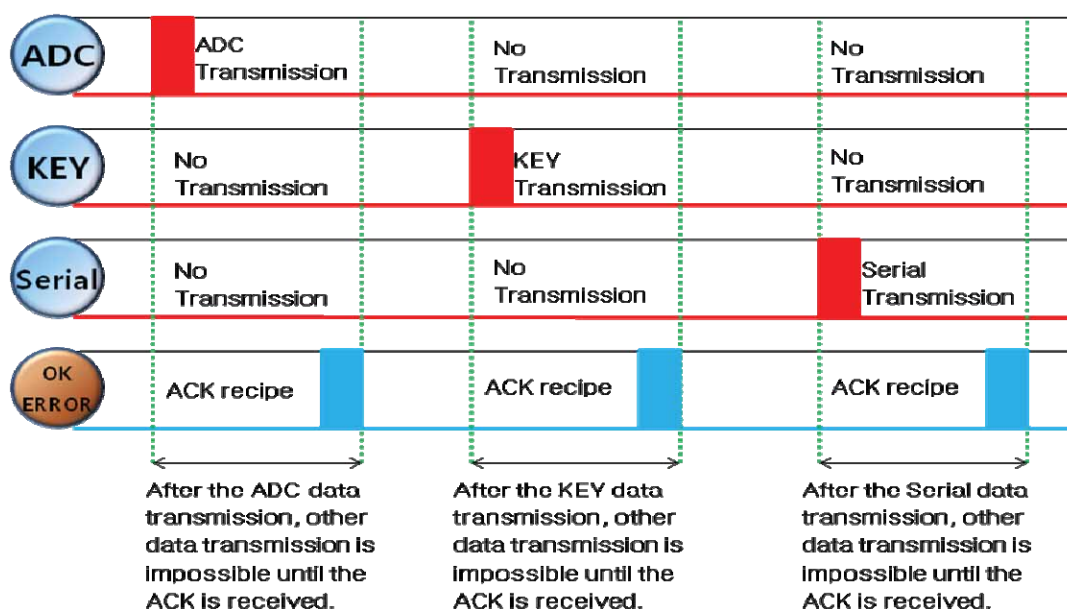

< FZ750BS/FZ750BC data transmission Interaction >

(15) FZ750BS/FZ750BC supports Low power consumption mode when it is set to End Device.

The terms of wake-up:

Low power consumption mode 1: Internal time, KEY port, Re-set

Device is not reset after wake-up.

(Except for the “Re-set” in terms of low power consumption mode 1)

Low power consumption mode 2: Internal time, KEY port, Re-set

Device is reset after wake-up.

Low power consumption mode 3: KEY port, Re-set

Device is not reset after wake-up

Serial data Input and data transmission is not possible while FZ750BS/FZ750BC is in a low power consumption mode

- ⇒ All received Serial data is ignored while FZ750BS/FZ750BC is in a low power consumption mode.
- ⇒ All received data is ignored while FZ750BS/FZ750BC is in a low consumption mode
- ⇒ In order to input Serial data into FZ750BS/FZ750BC in a low power consumption mode, you should wait until FZ750BS/FZ750BC makes wake-up by internal time or use a KEY port to wake FZ750BS/FZ750BC up, and then input the Serial data. Also, you can input the Serial data after resetting the FZ750BS/FZ750BC, as well.
- ⇒ **The major function of End Device in the Zigbee Network is ADC data and KEY data transmission.**

(16) FZ750BS/FZ750BC has an IEEE ADDRESS and a NETWORK ADDRESS.

64 Bit IEEE ADDRESS is a physical address of FZ750BS/FZ750BC.

Every device has its own IEEE ADDRESS and the IEEE ADDRESS is not changeable.

FZ750BS/FZ750BC set target devices by using IEEE ADDRESS.

In conclusion, “**target device set-up**” is an inquiry using IEEE ADDRESS for NETWORK ADDRESS of its target devices

FZ750BS/FZ750BC has a 16 Bit of NETWORK ADDRESS for the Zigbee Network communication.

NETWORK ADDRESS is given when FZ750BS/FZ750BC participates in the Zigbee Network

NETWORK ADDRESS can be changed depending on the Zigbee Network Configuration.

NETWORK ADDRESS cannot be shown unless FZ750BS/FZ750BC participates in the Zigbee Network.

FZ750BS/FZ750BC performs data transmission by using NETWORK ADDRESS.

(17) If you configure the Zigbee Network and perform data transmission, the result value is shown as **[volume of received data > volume of transmitted data]**

FZ750BS/FZ750BC on a MAC layer automatically re-transmits data depending on the Zigbee Network Configuration.

In case of using ACK option, FZ750BS/FZ750BC on an application layer automatically re-transmits data depending on the Zigbee Network Configuration. Thus, **Received data could be more than 2 depending on the Zigbee network configuration even if only one data is transmitted.**

※ < **Routing table update of FZ750BS/FZ750BC**>

Routing table is assigned to each FZ750BS/FZ750BC after the Zigbee Network Configuration.

Below is the Zigbee network status when data is transmitted from Router2 to Router1 to Coordinator.

Data is input into Router2, the Router2 transmits the data to Router1, and then the Router1 transmits the data to Coordinator. Consequently, the data inputted into Router2 is transmitted to Coordinator by routing table belonging to Router2 and Router1

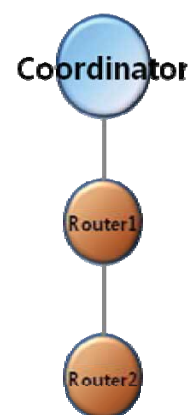

If Router 1 is in abnormal status in the Zigbee Network, Router2 cannot transmit data, and shows its error status through ERROR port.

When ACK Option is disabled (**NACK communication**) of FZ750BS/FZ750BC, Device is automatically reset and Router2 creates a new routing table if the Router2 happens to show its error status 5times successively through the error port because of the abnormal Router1. Multipath set-up is required ahead of the time to update the routing table.

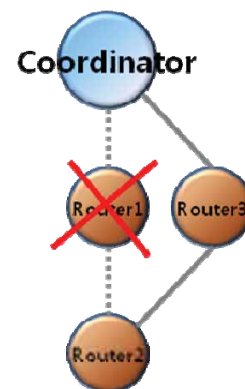

When the ACK Option of FZ750BS/FZ750BC is enabled (**ACK communication**), users should control the routing table directly to update it. If the data transmission is successively failed, users need to reset its target device's address (**same as the existing one**) and the Device.

1-3. Operation of FZ750BS/FZ750BC and Interface Boards

We explain it with FZ750BS/FZ750BC which has the initial factory set value.

(1) FZ750BS/FZ750BC automatically searches a Zigbee coordinator or a parent node and tries to participate in the Network.

If FZ750BS/FZ750BC outputs “ROUTER START ERROR”, that means the FZ750BS/FZ750BC is failed to participate in the Zigbee Network.

If FZ750BS/FZ750BC outputs “ROUTER START OK”, that means a Zigbee Coordinator is around or FZ750BS/FZ750BC is successfully participated in the Zigbee Network with its parent node. RX / TX port of FZ750BS/FZ750BC are connected to RS-232 on an Interface board. Messages from FZ750BS/FZ750BC are shown on a screen through RS-232 on an Interface Board connected to PC.

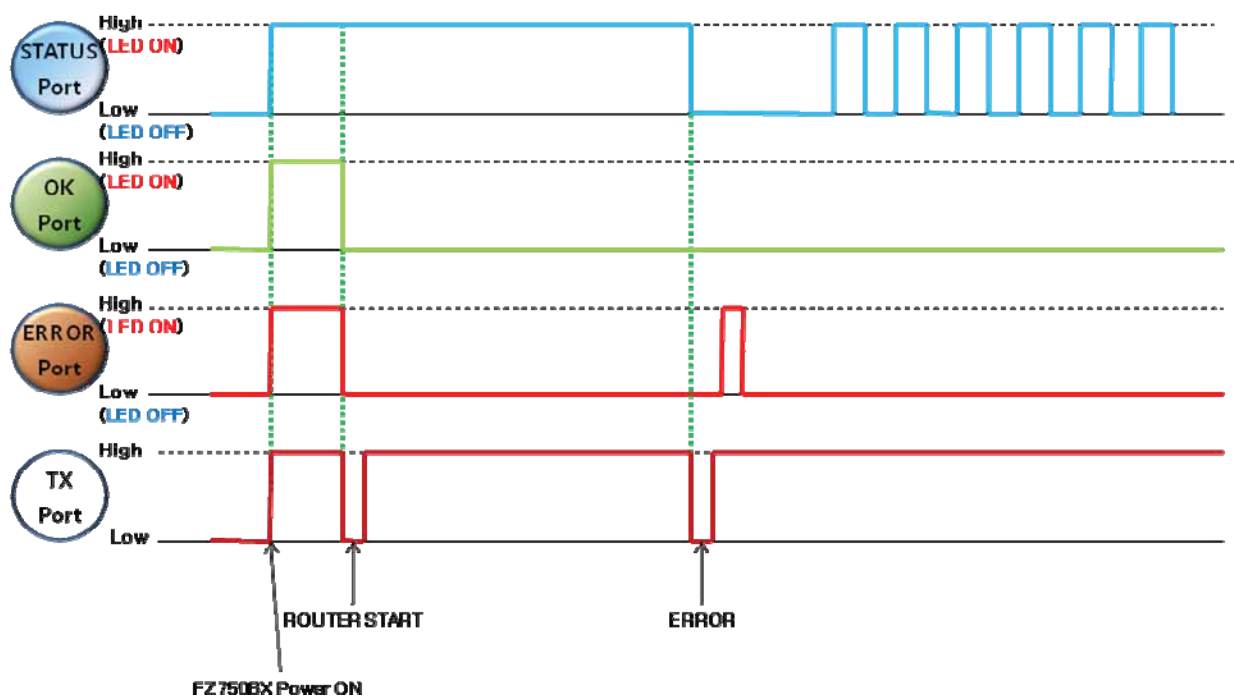

< FZ750BS/FZ750BC is failed to participate in the Zigbee Network/ Operation of Each port >

(2) If FZ750BS/FZ750BC is failed to participate in the Zigbee Network, STATUS port outputs High and Low repeatedly.

STATUS port of FZ750BS/FZ750BC is connected to STATUS LED on an Interface Board. STATUS LED on an Interface board flickers quickly, which means the Zigbee Network Participation is failed.

If FZ750BS/FZ750BC is successfully participated in the Zigbee Network, STATUS port shows “High –> Low –> High”. (None target devices)

STATUS LED on an interface board flickers once.

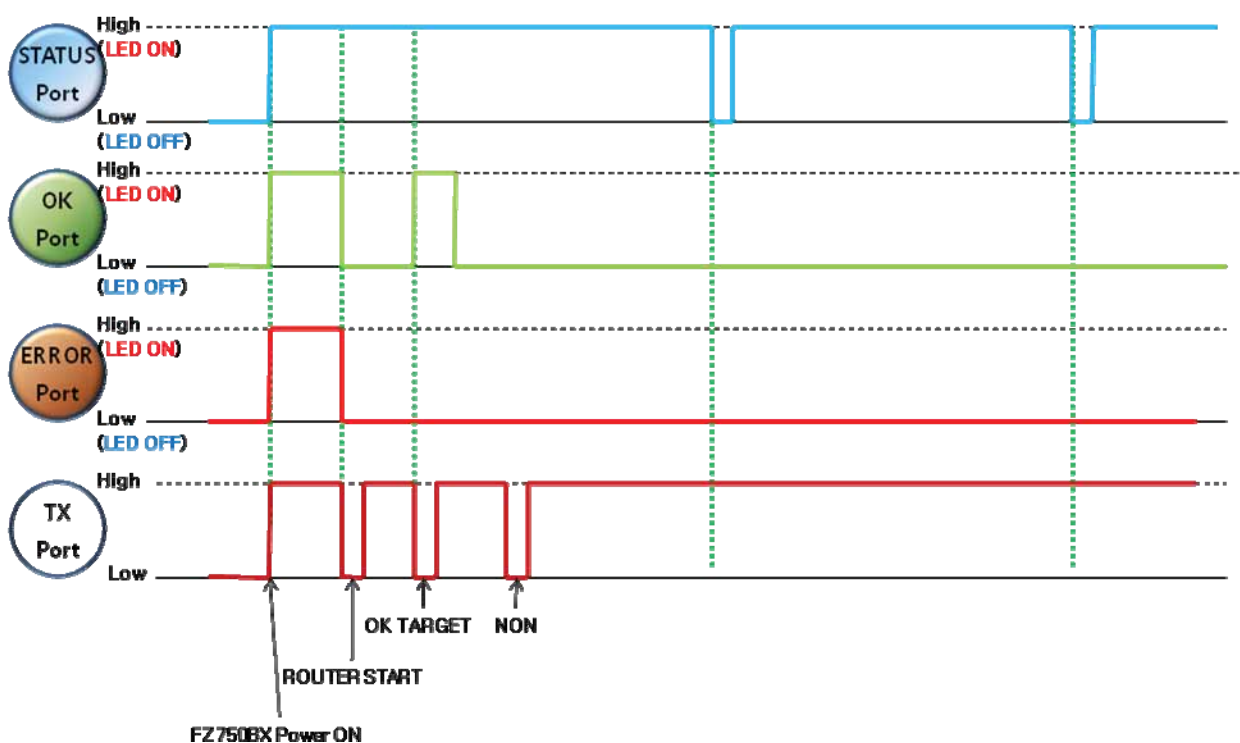

< FZ750BS/FZ750BC is successfully participated in the Zigbee Network (None target devices)/
Operation of Each port >

(3) FZ750BS/FZ750BC automatically sets target devices after the Zigbee Network Participation.

After FZ750BS/FZ750BC is participated in the Zigbee Network, It outputs a message “ROUTER START OK”. After that, a message “TARGET NON” comes up on the screen shortly.

The message “TARGET NON” means that a target device’s address is not saved.

If FZ750BS/FZ750BC saves a target device’s address, FZ750BS/FZ750BC outputs “TARGET OK” or “TARGET ERROR”. The message “TARGET OK” means that the target device is participated in the Zigbee Network and the target device is set-up properly. The message “TARGET ERROR” means that the saved target Device is not participated in the Zigbee Network or the target device is improperly set.

(4) When a target device is set, High value is output from STATUS port.

If FZ750BS/FZ750BC successfully sets its target device, STATUS LED on an interface board turns ON.

If FZ750BS/FZ750BC fails to set its target device, STATUS port outputs High and Low repeatedly. STATUS LED on an Interface Board flickers once.

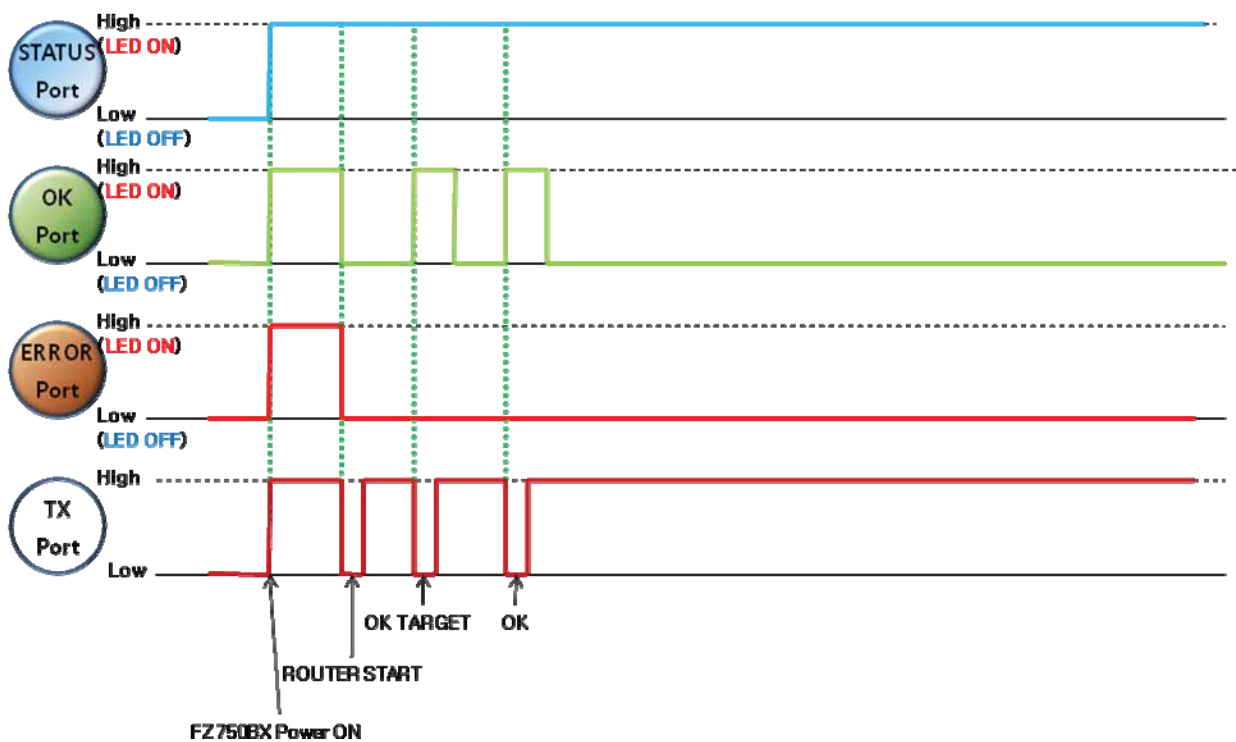

< A target device is successfully set-up/ Operation of each port >

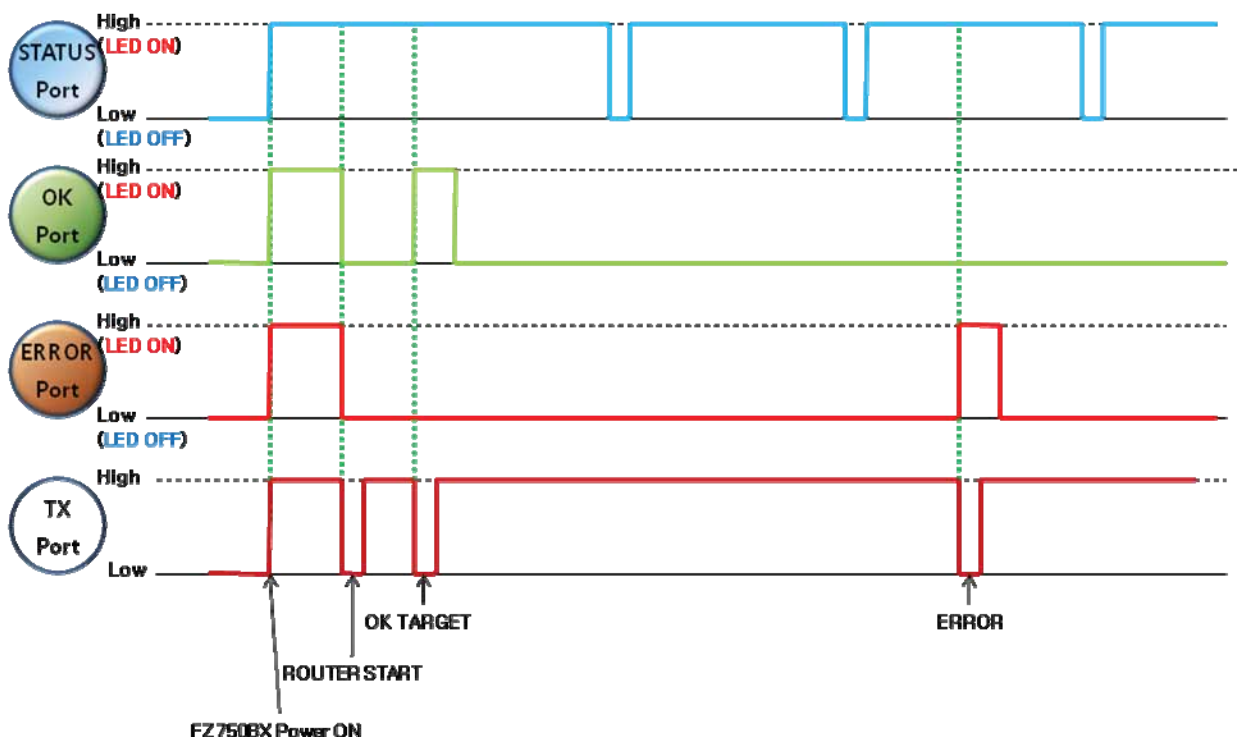

< A target device is failed to set-up, Operation of each port >

- (5) Serial data Transmission becomes possible after FZ750BS/FZ750BC is participated in the Zigbee Network and the target device set-up is properly done.

Serial data transmission of FZ750BS/FZ750BC is basically enabled.

In order to perform Serial data Transmission using FZ750BS/FZ750BC, input Serial data into a RX port and press Enter key. Then, data is transmitted to a target device.

53 bit including Enter key is a maximum of data length for transmission.

Once the Serial data Input is started, other forms of data transmission are impossible until the process for Serial data transmission is finished.

RX port of FZ750BS/FZ750BC is connected to RS-232 on an Interface Board.

- (6) ADC data transmission becomes possible after FZ750BS/FZ750BC is participated in the Zigbee Network and the target device set-up is properly done.

ADC data transmission of FZ750BS/FZ750BC is basically disabled.

In order to perform ADC data transmission using FZ750BS/FZ750BC, set the ADC Transmission to be enabled by using a command “AT+SETADC1”. And then, input ADC data into ADC port. Then, **FZ750BS/FZ750BC reads the ADC port every certain time, changes Analog data to Digital Data, and transmits the ADC data to its target device.**

A command “AT+SETTMR10 (10 seconds)” is used for setting internal time.

ADC port of FZ750BS/FZ750BC is connected to variable resistance on an Interface board.

- (7) KEY data transmission becomes possible after FZ750BS/FZ750BC is participated in the Zigbee Network and its target device set-up is properly done.

KEY data transmission of FZ750BS/FZ750BC is basically disabled.

In order to perform KEY data transmission using FZ750BS/FZ750BC, set the KEY Transmission to be enabled by using a command “AT+SETKEY1”.

If FZ750BS/FZ750BC is a Coordinator or a Router, KEY data transmission is possible regardless of the KEY option, but if FZ750BS/FZ750BC is an End Device, KEY data transmission is subject to the KEY option.

In order to perform KEY data transmission using FZ750BS/FZ750BC, input KEY data into KEY port. And then, **FZ750BS/FZ750BC creates a certain form of KEY data and transmits it to its target device.**

KEY port of FZ750BS/FZ750BC is connected to a KEY switch on an Interface Board.

- (8) COUNT data transmission becomes possible after FZ750BS/FZ750BC is participated in the Zigbee Network and its target device set-up is properly done.

COUNT data transmission of FZ750BS/FZ750BC is basically disabled.

In order to perform COUNT data transmission using FZ750BS/FZ750BC, set the COUNT Transmission to be enabled by using a command “AT+SETCOUNT1”.

COUNT data transmission of FZ750BS/FZ750BC is possible only when ADC data is transmitted.

In conclusion, “ADC Enabled + COUNT Enabled (1)”: COUNT data instead of ADC data is transmitted to a target device once every set time.

“ADC Enabled + COUNT Disabled (0)”: ADC data is transmitted to a target device once every set time.

“ADC Disabled + COUNT Enabled (1)”: None of them are transmitted.

COUNT data transmission cannot be done at the same time as when GPIO value is transmitted.

In order to send COUNT Data, set GPIO use terms to be disabled by using a command “AT+SETGPIO0” for COUNT data transmission.

- (9) GPIO Value Transmission becomes possible after FZ750BS/FZ750BC is participated in the Zigbee Network and its target device set-up is properly done.

GPIO Use of FZ750BS/FZ750BC is basically disabled.

In order to send GPIO Value using FZ750BS/FZ750BC, set the GPIO Use Terms to INPUT by using a command “AT+SETGPIO1”.

GPIO Value Transmission of FZ750BS/FZ750BC is possible only when KEY data or ADC data is transmitted.

In conclusion,

“KEY Enabled + GPIO INPUT(1)” : If KEY data is input, GPIO Value instead of the KEY data is transmitted to a target device.

“ADC Enabled + GPIO INPUT(1)” : GPIO Value instead of the ADC data is transmitted to a target device once every set time.

GPIO Value Transmission cannot be done at the same time as when COUNT data is transmitted.

In order to send GPIO Value, set the use terms of COUNT data transmission to be disabled by using a command “AT+SETCOUNT0” for GPIO Value Transmission.

(10) Wireless Transmission becomes possible after FZ750BS/FZ750B is participated in the Zigbee Network.

If FZ750BS/FZ750BC is set to a target device, TX port outputs received data from the Device that transmits wireless data. The TX port is connected to RS-232 on an Interface board.

If FZ750BS/FZ750BC receives KEY Data, it outputs “KEY_EVT_0015510000000000B” through Serial

If FZ750BS/FZ750BC receives ADC Data, it outputs “ADC0012_0015510000000000B” through Serial

If FZ750BS/FZ750BC receives Serial Data, it outputs the data as it is through Serial.

If FZ750BS/FZ750BC receives COUNT Data, it outputs “CNT0005_0015510000000000B” through Serial.

If FZ750BS/FZ750BC receives GPIO Value, It outputs “GPT007F_0015510000000000B” through Serial.

GPIO Use Terms of FZ750BS/FZ750BC is set to OUTPUT, the FZ750BS/FZ750BC outputs GPIO value through a GPIO port.

To check the GPIO Output Value of FZ750BS/FZ750BC, connect the GPIO port to LED on an Interface board.

A command “AT+SETGPIO2” is used to set GPIO to OUTPUT.

A receipt of KEY data : **KEY_EVT_0015510000000000B**WrWn

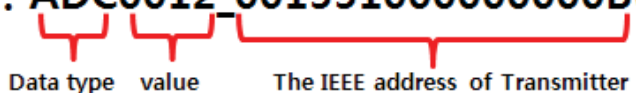
A receipt of ADC data : **ADC0012_0015510000000000B**WrWn

A receipt of Serial data : **123456789abcdefg**WrWn

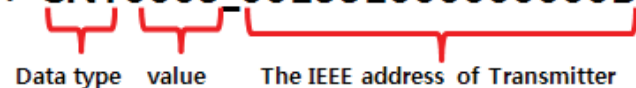
A receipt of Count data : **CNT0005_0015510000000000B**WrWn

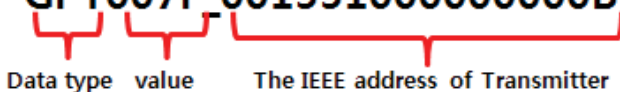
A receipt of GPIO data : **GPT007F_0015510000000000B**WrWn

< FZ750BS/FZ750BC Received data Type >

(11) FZ750BS/FZ750BC has OK port and ERROR port to show status for results.

OK / ERROR ports of FZ750BS/FZ750BC are connected to OK / ERROR LED on an interface board.

If FZ750BS/FZ750BC is failed to participate in the Zigbee Network, ERROR port outputs Low and “High” repeatedly. ERROR LED on an interface board flickers once.

If FZ750BS/FZ750BC is participated in the Zigbee Network, OK port outputs Low and High repeatedly. OK LED on an Interface board flickers once.

If any target devices of FZ750BS/FZ750BC are not saved, nothing is output from the OK/ ERROR port. OK port outputs Low and High repeatedly when the target Set-up is completed.

OK LED on an Interface board flickers once.

If the target Set-up is failed, ERROR port outputs Low and High repeatedly.

ERROR LED on an Interface board flickers once.

If Serial data is inputted when a target device set-up is not completed, ERROR port outputs Low and High repeatedly. ERROR LED on an Interface board flickers once.

If KEY data is inputted when a target device set-up is not completed, nothing is output from the OK/ERROR ports.

If data transmission is successfully done, OK port outputs Low and High repeatedly.

OK LED on an Interface board flickers once.

If data transmission is failed, ERROR port outputs Low and High repeatedly.

ERROR LED flickers once.

The next data transmission may be performed after checking OK/ERROR LED for current data transmission.

(12) When FZ750BS/FZ750BC is in an operation mode, OK port and ERROR ports basically keep Low, but output Low and High repeatedly in case of getting result value.

While FZ750BS/FZ750BC is in an operation mode, OK / ERROR LED on an Interface board keep to be turned OFF, but flicker once (LED ON) for the result value.

(13) FZ750BS/FZ750BC is in an AT command mode, OK port and ERROR port keep High. STATUS port of FZ750BS/FZ750BC becomes Low.

If FZ750BS/FZ750BC is changed from an operation mode to AT command mode, OK port and ERROR port are changed to High from Low. Status port becomes Low. OK/ERROR LED on an Interface board are turned ON. STATUS LED is turned OFF.

Change the Operation mode to the AT command mode by using a command “+++”

A message “OK” is output from TX port of FZ750BS/FZ750BC.

When the mode is changed from AT Command to operation mode, OK and ERROR ports are also changed from High to Low. The STATUS port is changed depending on exiting value.

The OK / ERROR LED on an Interface Board are turned OFF. The STATUS LED is changed depending on existing value.

Change the mode from AT Command to Operation by using a command “ATO” .

A message “OK” is output from the TX port of FZ750BS/FZ750BC.

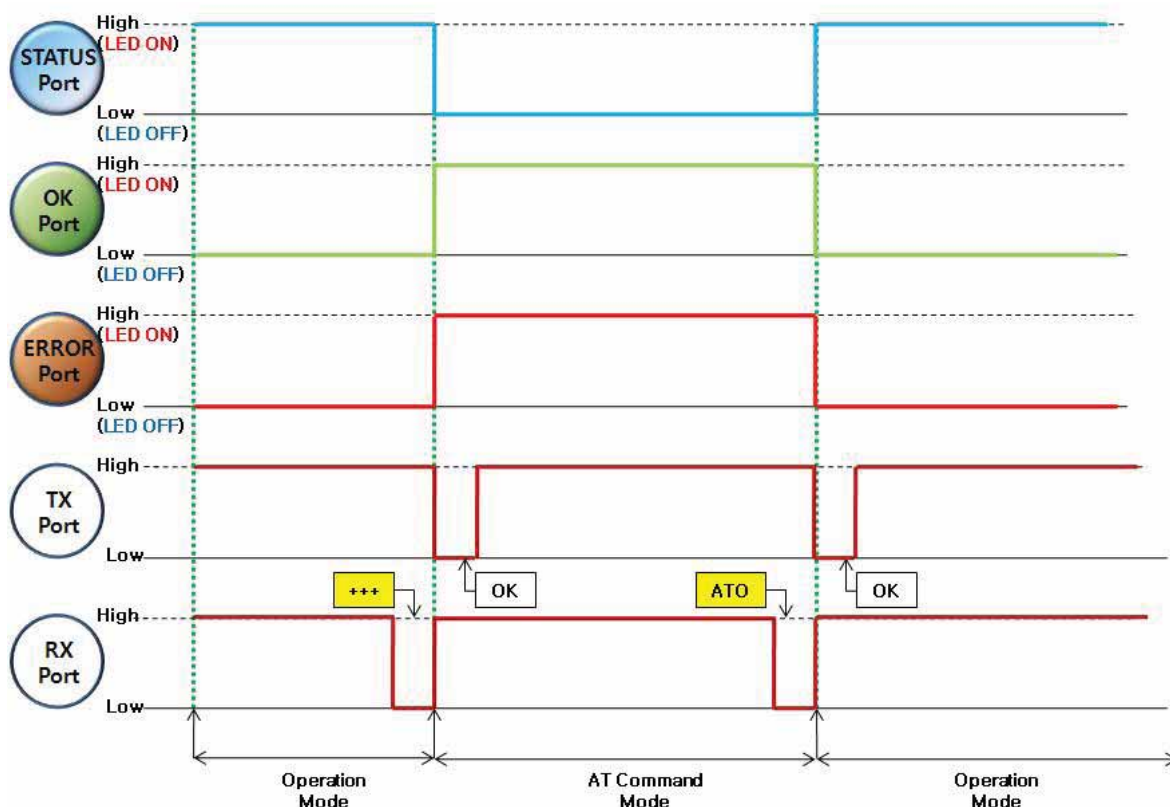

< Operation of each port in the operation mode and the AT command mode >

(14) FZ750BS/FZ750BC is set to End Device, and its target device is set.

FZ750BS/FZ750BC enters into a low power consumption mode.

STATUS / OK / ERROR ports of FZ750BS/FZ750BC changed to High.

STATUS/OK/ERROR LED on an Interface board is turned ON.

(15) If wake-up from End Device in a low power consumption mode occurs, OK and ERROR ports are changed to Low.

STATUS port keeps High because the End Device has a target device.

STATUS LED on an Interface board keeps being turned ON.

OK / ERROR LED on an Interface board are turned OFF.

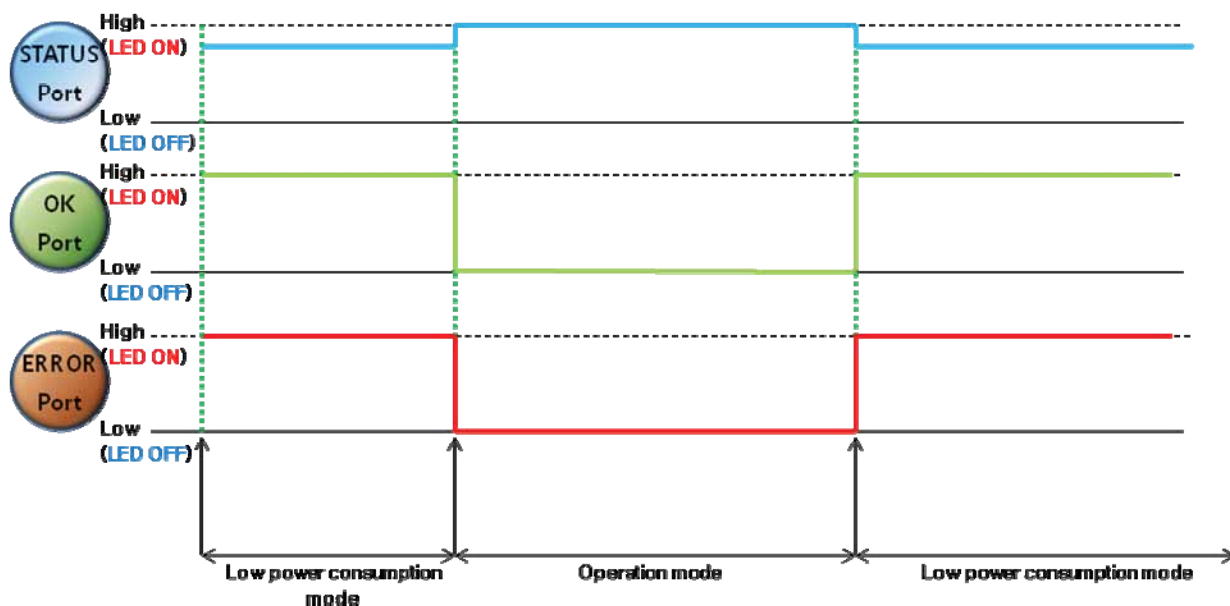

< Operation of each port in a Low power consumption mode and an Operation mode (Low power consumption mode 1) >

1-4. Features of End Device

End Device has differences in a way to manage its operation compared to Coordinator and Router.

Do not set End Device to a target device of other Devices.

Once End Device starts to operate, (After target device set-up) it automatically enters into a low power consumption mode. The End Device in a low power consumption mode ignores all data that is transmitted or inquired from other Devices.

The major function of End Device is transmitting ADC/KEY data to its target device (Router or coordinator).

While the End Device is in a wake-up mode (about 1 sec), it functions almost same as Coordinator or Router. However, the End Device happens to function differently at the moment when the wake-up occurs in a low power consumption mode.

The following are notable features of End Device.

- (1) Internal time (AT+SETTMR) is used for ADC data transmission in case of coordinator and Router. For example, if "AT+SETTMR60" is set, the Coordinator or Router reads ADC port once every 60 seconds and send it to its target device. (ADC Option Enabled)
However, in case of End Device, **Internal time (AT+SETTMR) is used for wake-up time in low power consumption mode.** For example, if "AT+SETTMR60" is set, wake-up from End device occurs once every 60 sec. **(This does not apply to the Low power consumption mode 3)**
- (2) If data is inputted into KEY port, Coordinator or Router transmits the KEY data to its target device regardless of KEY option. In case of End Device, however, it may happen only while the End Device makes wake-up with KEY option set to be enabled. **(This does not apply to the Low power consumption mode 1.** The End Device in a low power consumption mode1 does not transmit KEY data even if wake-up occurs.) End Device makes wake-up in a low power consumption mode if data is inputted into KEY port.

Wake-up from End Device in a low power consumption mode 1 occurs when KEY port meets Rising Edge (Low -> High)

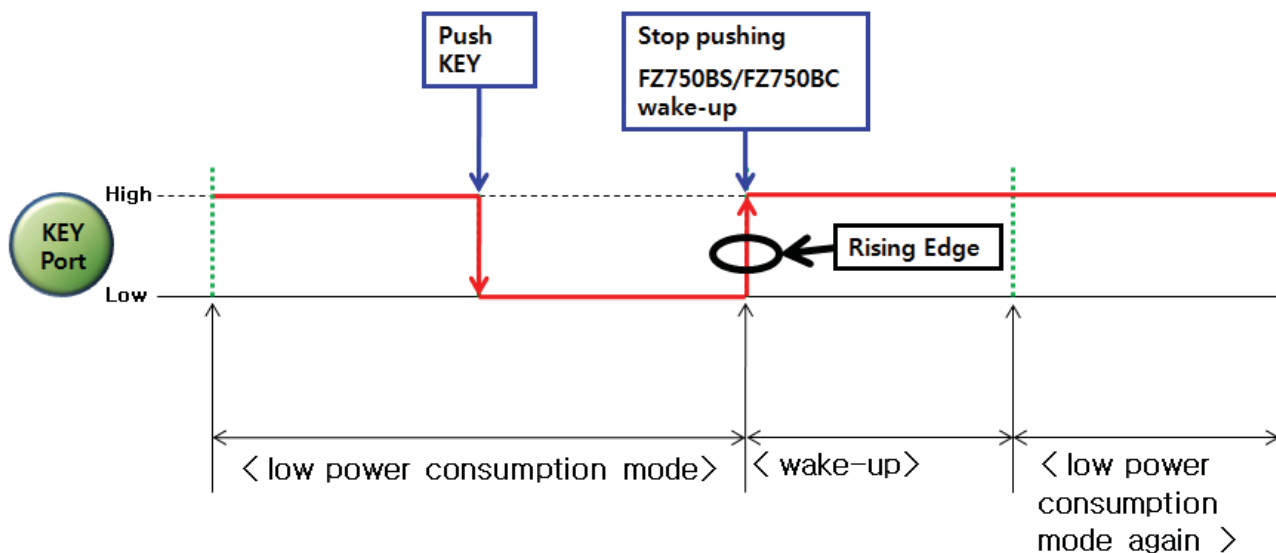

< FZ750BS/FZ750BC Low power consumption mode 1, Wake-up point >

Wake-up from End device in a low power consumption mode 2 /3 occurs when KEY port becomes Low.

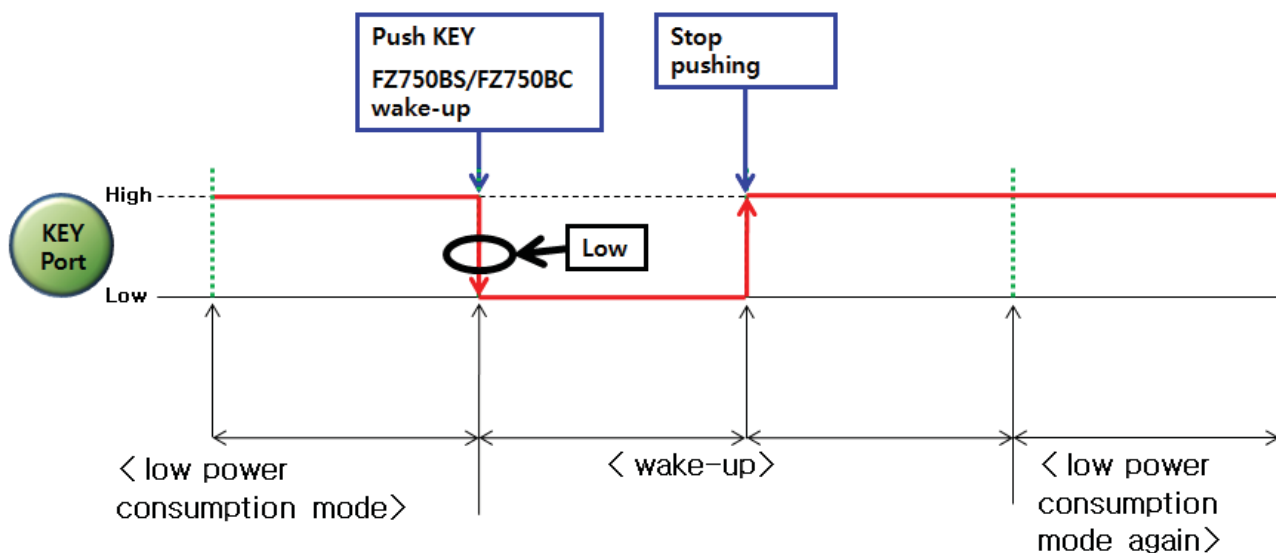

< FZ750BS/FZ750BC Low power consumption mode 2 or 3 , Wake-up point >

- (3) Coordinator or Router can transmit Serial data to its target device by inputting Serial data unless they are put on standby for ACK after data transmission. However, End Device in a low consumption mode ignores all inputted Serial Data.

In order for End Device to transmit Serial Data, put the End Device in a wake-up mode, and see if the End Device operates.

End Device transmits Serial data to its target device when it is not in an operation mode. If Serial data is inputted when End Device does not operate, the Serial data is transmitted to the target device.

- (4) End Device – Low power consumption mode 1

Once End Device set its target device, it automatically enters into a Low power consumption mode. The End Device in a Low power consumption mode1 uses 25uA.

The major function of End Device in a Low power consumption mode1 is ADC / KEY data transmission.

If ADC Option of End Device in a Low power consumption mode1 is enabled, the End Device makes wake-up by internal time and transmits ADC data to its target device.

If KEY option of End Device in a Low power consumption mode1 is enabled, the End Device makes wake-up by inputting KEY data and send KEY data to its target device.

If KEY option of End Device in a Low power consumption mode1 is disabled, the End Device makes wake-up by inputting KEY data and enters into a Low power consumption mode again after 1 second.

Serial data transmission is possible by inputting Serial data before the End Device enters into the Low power consumption mode again.

- (5) End Device – Low power consumption mode 2

Once End Device set its target device, it automatically enters into a Low power consumption mode. The End Device in a Low power consumption mode1 uses 2uA.

The major function of End Device in a Low power consumption mode2 is ADC data transmission.

If ADC Option of End Device in a Low power consumption mode2 is enabled, the End Device makes wake-up by internal time and is reset. After that, its target device is automatically set, and the End Device transmits ADC data to the target device.

If ADC Option of End Device in a low power consumption mode2 is enabled, the End Device makes wake-up with inputted KEY Data, and is reset. After that, its target device is automatically set, and the End Device transmits ADC data to the target device.

If KEY data is inputted when End Device is in a wake-up mode, the End Device transmits the KEY data to its target device. (KEY option should be enabled)

In case that ADC Option is disabled, KEY option is enabled, and internal time is set, End Device in a low power consumption mode2 makes wake-up by Internal time and is reset. After that, its target device is set and the End Device transmits KEY data to the target device. In conclusion, End Device based on a low power consumption mode2 mainly performs ADC data transmission by internal time owing to its significant feature.

In case of ADC option and KEY option are disabled, End Device in a low power consumption mode2 only makes wake-up after KEY data is inputted. After that, the End Device is reset and its target device is set. The End Device enters into a Low power consumption mode again 1sec after that.

If Serial data is inputted before the End Device enters into the low power consumption mode, the End Device transmits Serial data to its target device.

(6) End Device – Low power consumption mode 3

Once End Device sets a target device, it automatically enters into a Low power consumption mode. The End Device in a Low power consumption mode3 uses 1uA.

The major function of End Device in a Low power consumption mode3 is KEY data transmission.

End Device in a low power consumption mode3 does not make wake-up by internal time

KEY option is enabled, End Device makes wake-up in a low power consumption mode3 by inputting KEY data. After that, the End Device is reset and its target device is set. For the last, the End Device transmits KEY data to the target device.

If KEY data is inputted when End Device is in a wake-up mode, the End Device transmits KEY data to its target device. (KEY option should be enabled)

In case that KEY option is disabled, End Device only makes wake-up after KEY data is inputted. After that, the End Device is reset and its target device is set. The End Device enters into a low power consumption mode again 1 second after the target device set-up is completed. Serial data transmission is possible by inputting Serial data before End Device enters into a low power consumption mode.

(7) In order to put End Device in an AT command mode while the End Device operates, note the features mentioned above.

If End Device is in a low power consumption mode, put the End Device in a wake-up mode for data transmission. Input “+++” promptly after the End Device get receipt of ACK. It should be done before the End Device enters into a low power consumption mode again (It takes about 1 second).

(8) The following is the sequences regarding ADC Transmission when the End Device is in a **Low power consumption mode2**.

- ① End Device makes wake-up by internal time.
- ② End Device is reset
- ③ End Device participates in the Zigbee Network.
- ④ End Device sets its target device.
- ⑤ End Device transmits ADC data to its target device.
- ⑥ End Device receives ACK from its target device.
- ⑦ End Device is on standby for 1sec.
- ⑧ End Device enters into a low power consumption mode.

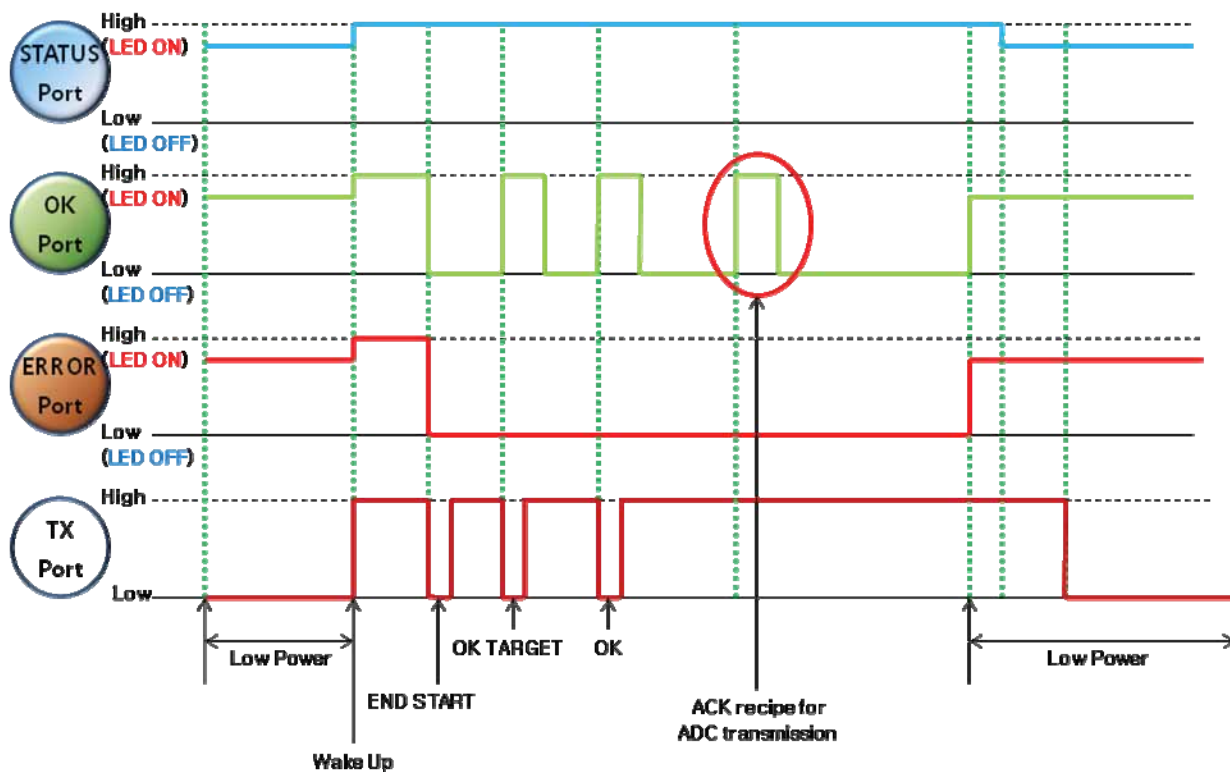

< Wake-up → Network Participation → Target Set-up → data transmission → Low power consumption mode >

2. Product Performance

2-1. FZ750BS/FZ750BC Performance

Part	Specification
Zigbee Spec.	Zigbee 2006 Specification Support
Communication Distance	120 M
Frequency Range	2.405~2.475 GHz ISM Band
Sensitivity	-98 dBm
Conducted Transmit Power	10 dBm
Size	20.54 mm X 27.70 mm X 9.40 mm
Input Power	3.3 V
Current Consumption	38 mA (Max)
Operating Temperature	-20 °C - +50 °C
Max Operating Temperature	-30 °C - +80 °C
Communication Speed	9,600 bps ~ 230,400 bps
Antenna	Chip or CMP Antenna
DATA Interface	UART (TTL Level), ADC(Analog Input), KEY(Digital Input), GPIO (Digital Input / Output)
STATUS Interface	STATUS / OK / ERROR

<Table 2-1 FZ750BS/FZ750BC Performance>

3. Current consumption

3-1. FZ750BS/FZ750BC Current Consumption

Device type		Current Consumption	
		Low Power Consumption mode	data transmission
Coordinator		-	38mA
Router		-	38mA
End Device	Wake-up	-	38mA
	Low power consumption mode1	25uA	-
	Low power consumption mode2	2uA	-
	Low power consumption mode3	1uA	-

<Table 3-1 FZ750BS/FZ750BC Current Consumption>

4. PRODUCT APPEARANCE

4-1. FZ750BS/FZ750BC Image & Dimension

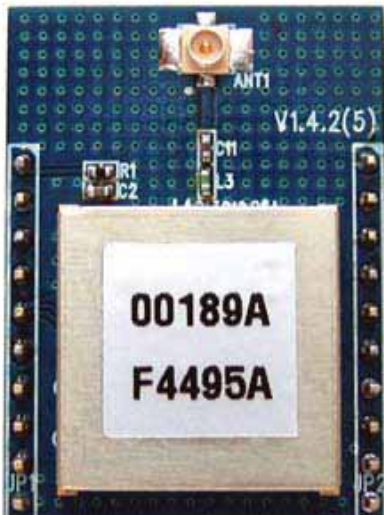

<Feature 4-1-① FZ750BS Image>



<Feature 4-1-② FZ750BC Image>

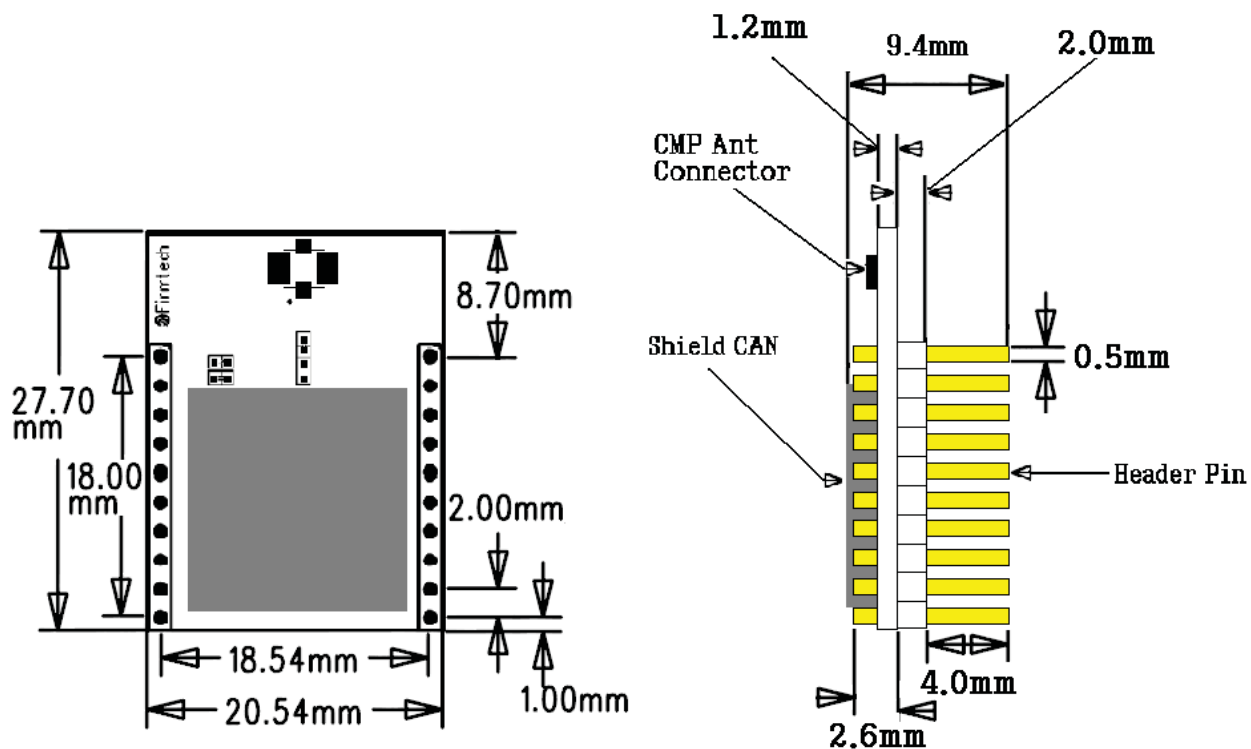

<Feature 4-1-③ FZ750BS Dimension>

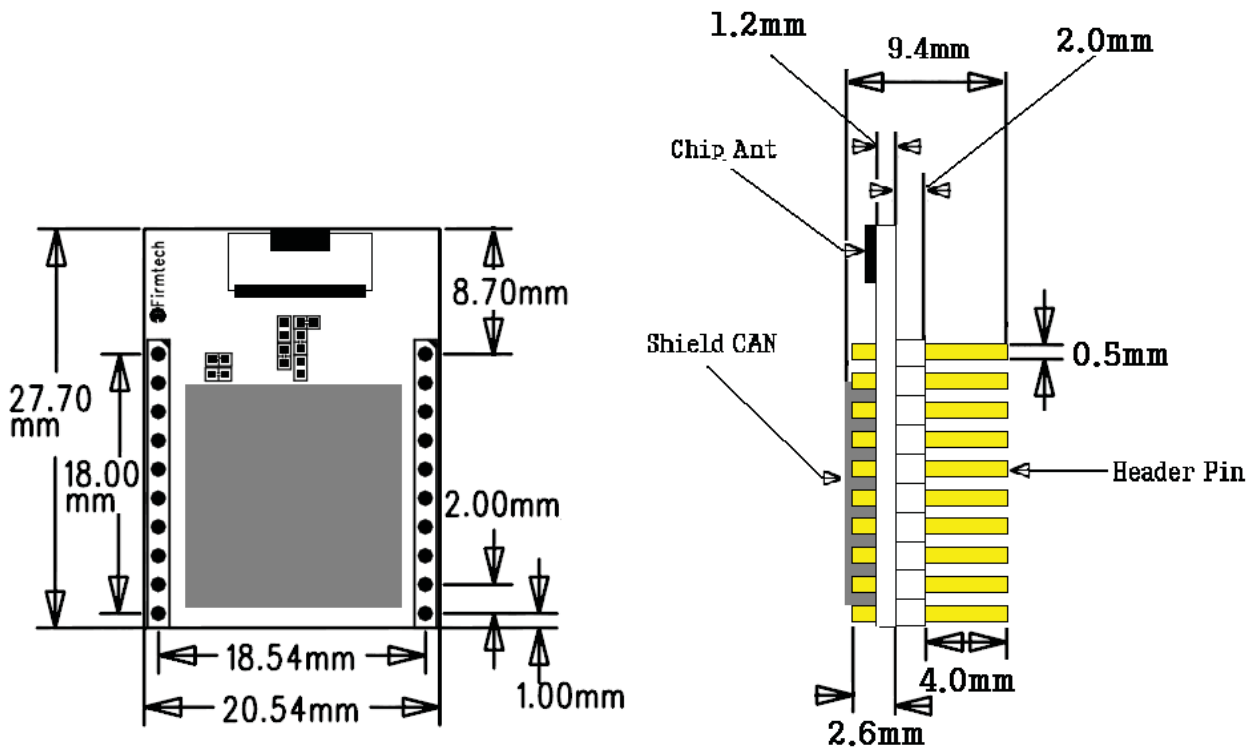

<Feature 4-1-④ FZ750BC Dimension>

4-2. FZ750BS/FZ750BC PIN Assign

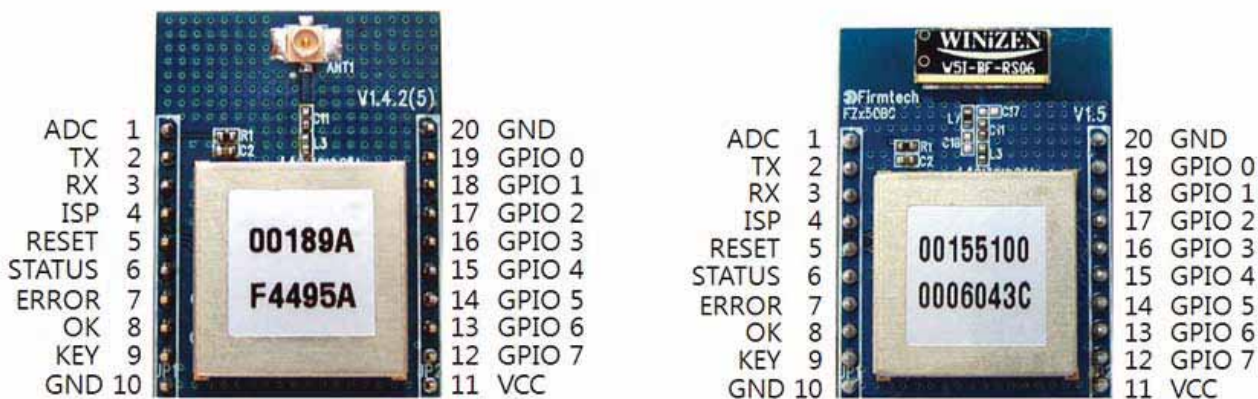

<Feature 4-2 FZ750BS/FZ750BC PIN Assign>

PIN NUMBER	NAME OF PORT	PERFORMANCE	DIRECTION OF INPUT/OUTPUT	REMARKS
1	ADC	Analog data Input	I	
2	TX	Transfer Data	O	
3	RX	Received Data	I	
4	ISP	-	-	
5	RESET	Device Reset	I	
6	STATUS	Display Status	O	
7	ERROR	Display Status	O	
8	OK	Display Status	O	
9	KEY	Digital data Input	I	
10	GND	-	-	
11	VCC	3.3V DC	I	
12	GPIO 7	Digital data Input / Output	I/O	
13	GPIO 6	Digital data Input / Output	I/O	
14	GPIO 5	Digital data Input / Output	I/O	
15	GPIO 4	Digital data Input / Output	I/O	
16	GPIO 3	Digital data Input / Output	I/O	
17	GPIO 2	Digital data Input / Output	I/O	
18	GPIO 1	Digital data Input / Output	I/O	
19	GPIO 0	Digital data Input / Output	I/O	
20	GND	-	-	

<Table 4-1 port Performance>

4-3. FZ750BS/FZ750BC Pin Description

4-3-1. ADC port

It is an Analog port of FZ750BS/FZ750BC.

A range of Input is from 0V to 1.5V.

(Do not input over 1.5V into an ADC port.)

FZ750BS/FZ750BC transmits 0000 to its target device if 0V is inputted into an ADC port.

FZ750BS/FZ750BC transmits 03FF to its target device if 1.5V is inputted into an ADC port.

It is connected to variable resistance of Interface Board.

4-3-2. TX port

It is an UART Output(TTL)port of FZ750BS/FZ750BC.

Received wireless data or responsive value from AT Command is output through a TX port.

It is connected to RS-232 RX port(EIA) on an Interface board.

4-3-3. RX port

It is an UART Input(TTL)port of FZ750BS/FZ750BC.

AT Command or Serial Communication data is inputted into a RX port.

It is connected to RS-232 TX port(EIA) on an Interface board.

4-3-4. ISP port

It is used for Firmware Update Configuration Set-up.

Do not connect anything to it because it can cause disturbance of Program.

4-3-5. RESET port

If Low(0V) is inputted into a RESET port, Software is reset.

It is connected to a Re-set switch on an Interface Board.

When RESET port operates improperly because of noise, or operates by abnormal timing set by users, the Zigbee Network can be disturbed. Therefore, any connections to the Reset port are not recommendable except when Firmware needs to be updated. ATZ command is recommended for Re-set instead.

4-3-6. STATUS port

It shows status of devices.

Status1. Device creates the Zigbee Network and Participates in it.

- ⇒ When Device creates the Zigbee Network and participates in it, STATUS port outputs High and Low slowly and repeatedly. STATUS LED on an Interface board flickers once.
- ⇒ If Device fails to create the Zigbee Network or participates in the Zigbee Network, a STATUS port outputs High and Low quickly and repeatedly. STATUS LED on an Interface Board quickly flickers.

Status2. Device sets its target device.

- ⇒ If FZ750BS/FZ750BC sets its target device, STATUS port outputs High. STATUS LED on an Interface Board is turned ON.
- ⇒ If FZ750BS/FZ750BC failed to set its target device, a STATUS port outputs High and Low slowly and repeatedly. STATUS LED on an interface Board flickers once.

When the mode of FZ750BS/FZ750BC is changed from Operation to AT Command, STATUS port is changed to Low. STATUS LED on an Interface board is turned OFF.

In case of End Device, STATUS port outputs High when the End Device is in a low power consumption mode. STATUS LED on an Interface Board is turned ON.

In case of End Device, STATUS port outputs High when the End Device makes wake-up in a low power consumption mode. STATUS LED on an Interface Board is turned ON.

4-3-7. ERROR port

It shows status of Devices.

While FZ750BS/FZ750BC operates after the Network initialization, ERROR port outputs Low. ERROR LED on an Interface board keeps being turned OFF.

It shows result value of operation.

- ⇒ If Device fails to create the Zigbee Network or participates in the Zigbee Network, ERROR port outputs Low, High and Low in order. ERROR LED on an Interface Board flickers once.
- ⇒ If data is sent to target device improperly, ERROR port outputs Low, High and Low in order. ERROR LED on an Interface board flickers once.

When the mode of FZ750BS/FZ750BC is changed from Operation to AT Command, ERROR port is changed to High. ERROR LED on an Interface board is turned ON.

In case of End Device, ERROR port outputs High when the End Device enters into a low power consumption mode. ERROR LED on an Interface Board is turned ON.

In case of End Device, ERROR port outputs Low when the End Device makes wake-up in a low power consumption mode. ERROR LED on an Interface Board is turned OFF.

4-3-8. OK port

It shows status of Devices.

While FZ750BS/FZ750BC operates after the Network initialization, OK port outputs Low. OK LED on an Interface board is turned OFF.

It shows result value of operation.

- ⇒ When Device creates the Zigbee Network and participates in it, OK port outputs Low, High and Low in order. OK LED on an Interface board flickers once.
- ⇒ If FZ750BS/FZ750BC sets its target device, OK port outputs Low, High and Low in order. OK LED on an Interface board flickers once.
- ⇒ If data is sent to target device properly, OK port outputs Low, High and Low in order. OK LED on an Interface Board flickers once.

When the mode of FZ750BS/FZ750BC is changed from Operation to AT Command, OK port is changed to High. OK LED on an Interface board is turned ON.

In case of End Device, OK port outputs High when the End Device enters into a low power consumption mode. OK LED on an Interface Board is turned ON.

In case of End Device, OK port outputs Low when the End Device makes wake-up in a low power consumption mode. OK LED on an Interface Board is turned OFF.

4-3-9. KEY port

It is a Digital Input port.

If Low (0V) is inputted into a KEY port, FZ750BS/FZ750BC notes that KEY data is inputted in it.

However, the judgments on KEY data inputted are subject to Device Type and mode of FZ750BS/FZ750BC.

End Device does not enter into a Low power consumption mode if a certain form of data remains inputted in a KEY port. The End Device enters into a low power consumption mode 1sec after the data in the KEY port is removed.

It is connected to KEY switch on an Interface board is connected.

4-3-10. GND port

It connects Low (0V) signal.

4-3-11. VCC port

It connects DC3.3V of voltage.

4-3-12. GPIO port

It is a port for Digital Input/output.

When GPIO port is used for Input, connect it to the switch on an interface board.

When GPIO port is used for Output, connect it to the LED on an interface board.

GPIO port consists of 8 bit (GPIO 0 ~ GPIO 7)

GPIO set value of FZ750BS/FZ750BC is High (1).

If GPIO port is set to INPUT, and the connected switch is pushed, Low (0) is inputted into a the GPIO port. The GPIO port also notices that the Low (0) is inputted.

If GPIO port is set to OUTPUT, and connected to the LED on an interface board, the GPIO port can receive wireless GPIO value, and output each value of bits.

If the received wireless GPIO value is High (1), GPIO port outputs High.

If the received wireless GPIO value is Low (0), GPIO port outputs Low.

If GPIO port outputs High, the LED on an Interface Board is turned OFF.

If GPIO port outputs Low, the LED on an Interface Board is turned ON.

5. Interface (Pin Connection)

5-1. Connection between a FZ750BS/FZ750BC and an Interface Board

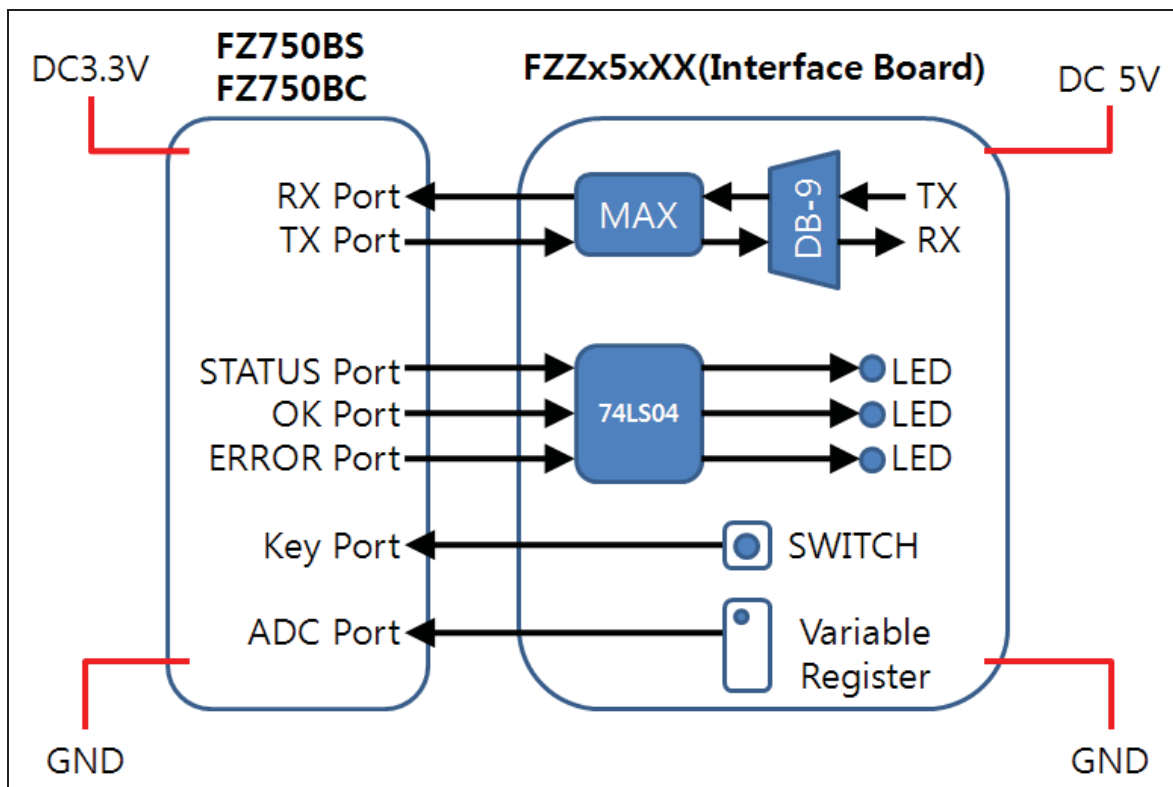

<Figure 5-1 Pin Connection between a FZ750BS/FZ750BC and an Interface Board.>

5-2. Pin Connection between a FZ750BS/FZ750BC and a MICOM

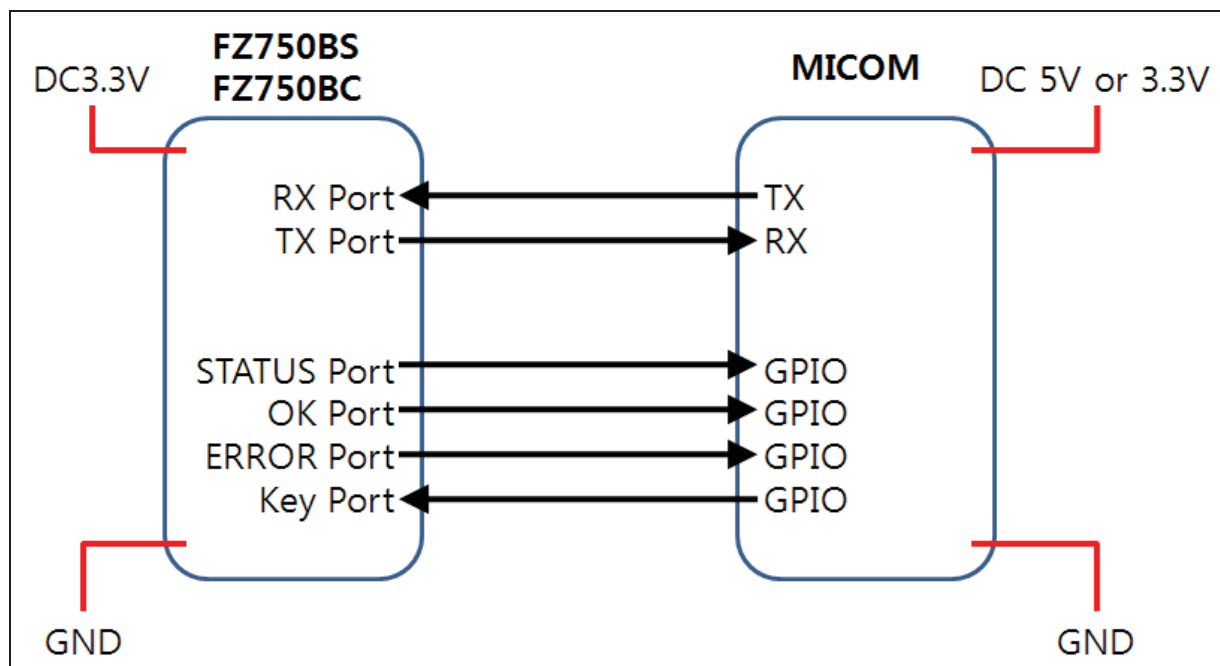

<Figure 5-2 Pin connection between and a FZ750BS/FZ750BC a MICOM>

5-3.Connection between a FZ750BS/FZ750BC and a PC

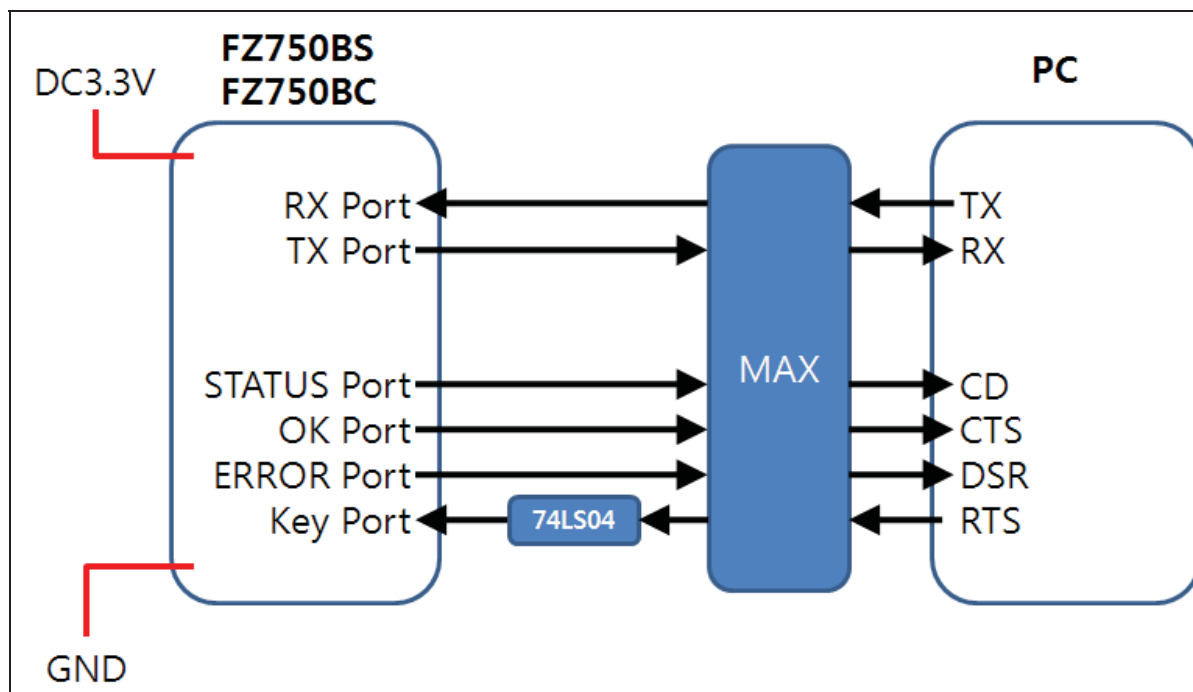

<Figure 5-3 Pin connection between and a FZ750BS/FZ750BC and a PC>

※ Information on 74LS04

74LS04 on an interface board is used for users' conveniences. Users can easily get know the operation status of FZ750BS/FZ750BC when STATUS port is connected to LED through the 74LS04. LED on an interface board is ACTIVE Low. LED is turned on when Low signal is inputted into it. If STATUS port is directly connected to LED without 74LS04, LED is turned off when STATUS port becomes High, and the LED is turned on when the STATUS port becomes Low. With 74LS04, LED is turned on when STATUS port becomes High, and the LED is turned when the STATUS port become Low.

74LS04 is used on a PC interface because the RTS Operation Point of PC is different from the KEY port Operation point of FZ750BS/FZ750BC.

KEY port of FZ750BS/FZ750BC normally keeps High(3V).

To transmit signal to KEY port, input Low(0V) into a KEY port or change the voltage from Low(0V) to High(3V).

RTS port of PC basically outputs High. RTS High Signal of PC is changed to Low through MAX. If the RTS Signal changed to Low is inputted into the KEY port of FZ750BS/FZ750BC, It may cause some problems. Thus, change the Low signal to High signal by using 74LS04, and input the changed signal before the RTS Signal of PC is inputted into the KEY port of FZ750BS/FZ750BC. This is the best proper way to transmit signal from PC to FZ750BS/FZ750BC.

5-4. Pin Connection between a GPIO port of FZ750BS/FZ750BC and MICOM (Extension Connection)

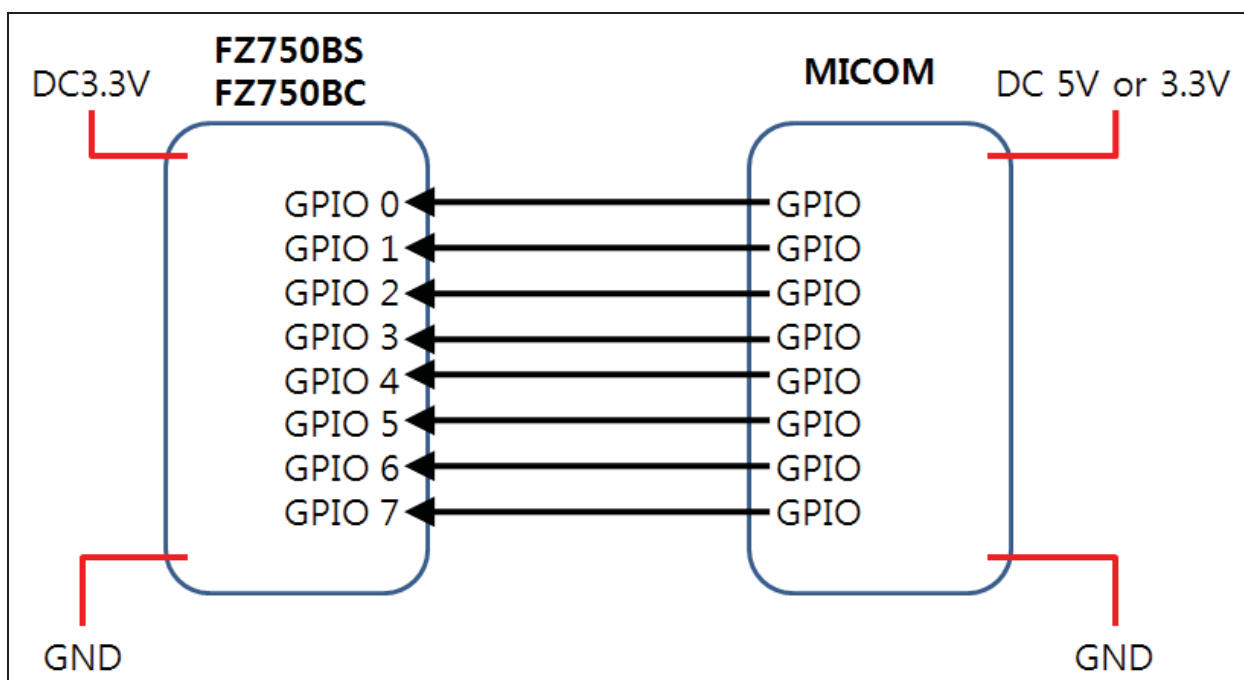

<Figure 5-4-1 Pin Connection between GPIO(INPUT) of FZ750BS/FZ750BC and MICOM>

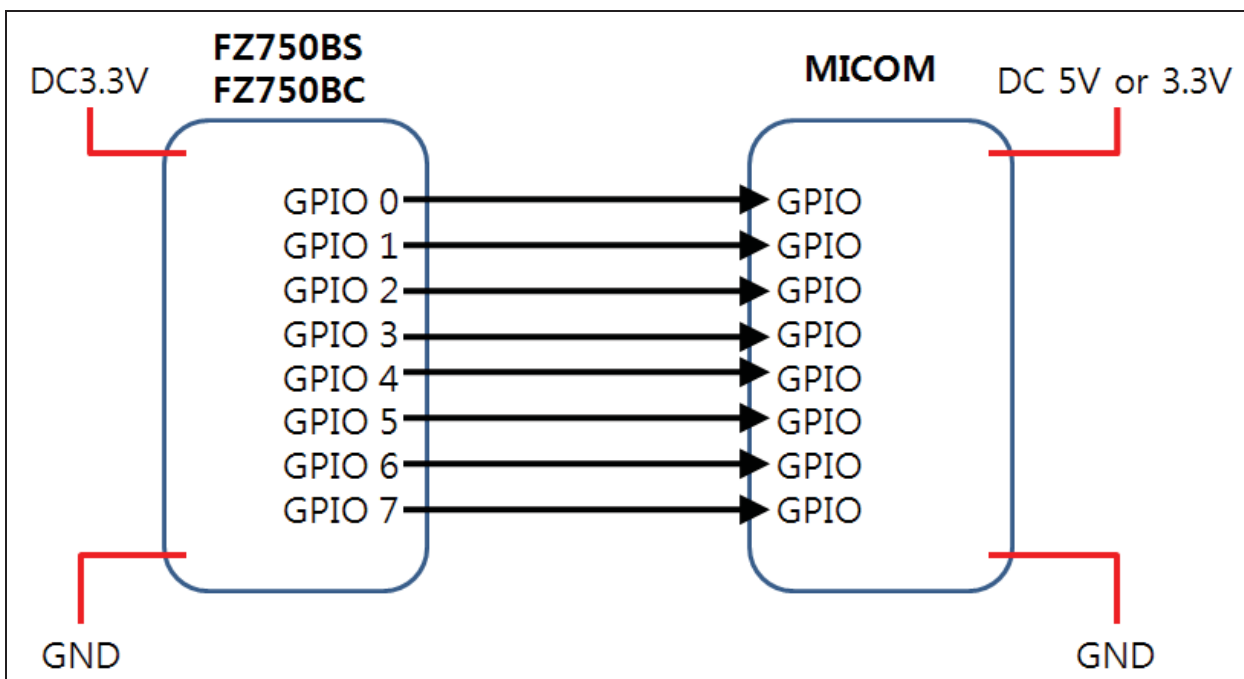

<Figure 5-4-2 Pin Connection between GPIO(OUTPUT) of FZ750BS/FZ750BC and MICOM >

5-5. Pin Connection between a GPIO port of FZ750BS/FZ750BC and an interface board (Extension Connection)

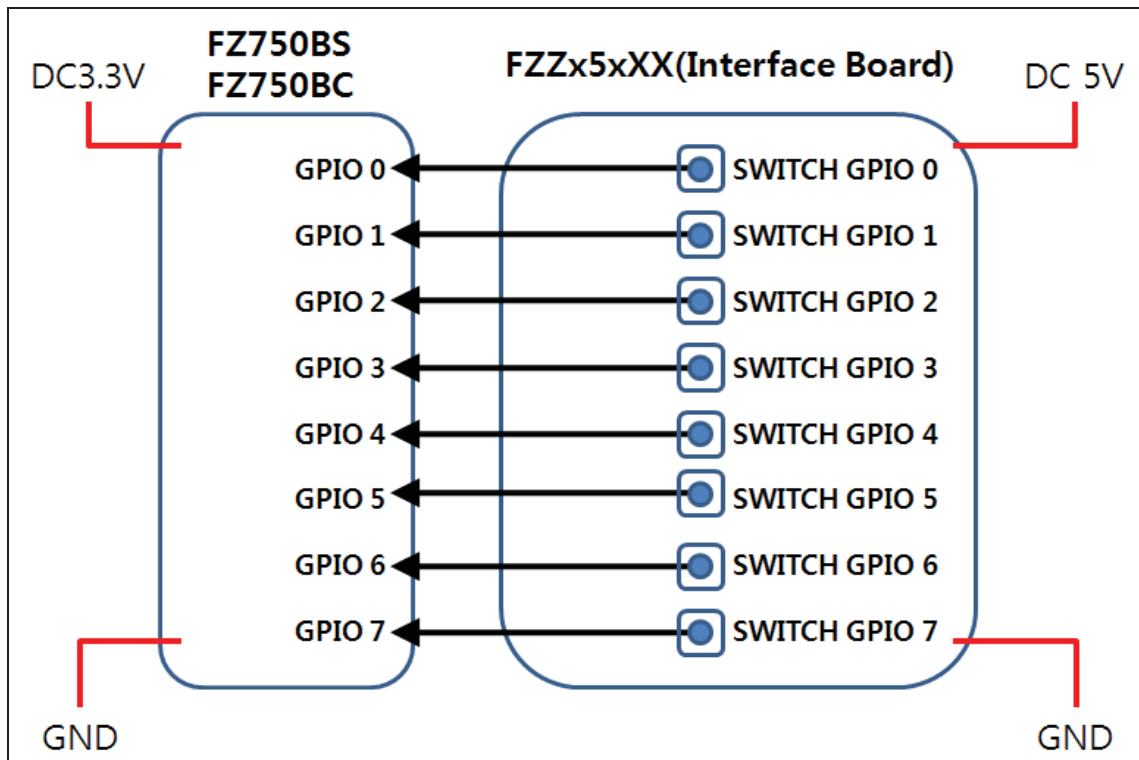

<Figure 5-5-1 Connection between a GPIO(INPUT) of FZ750BS/FZ750BC and an Interface Board SWITCH >

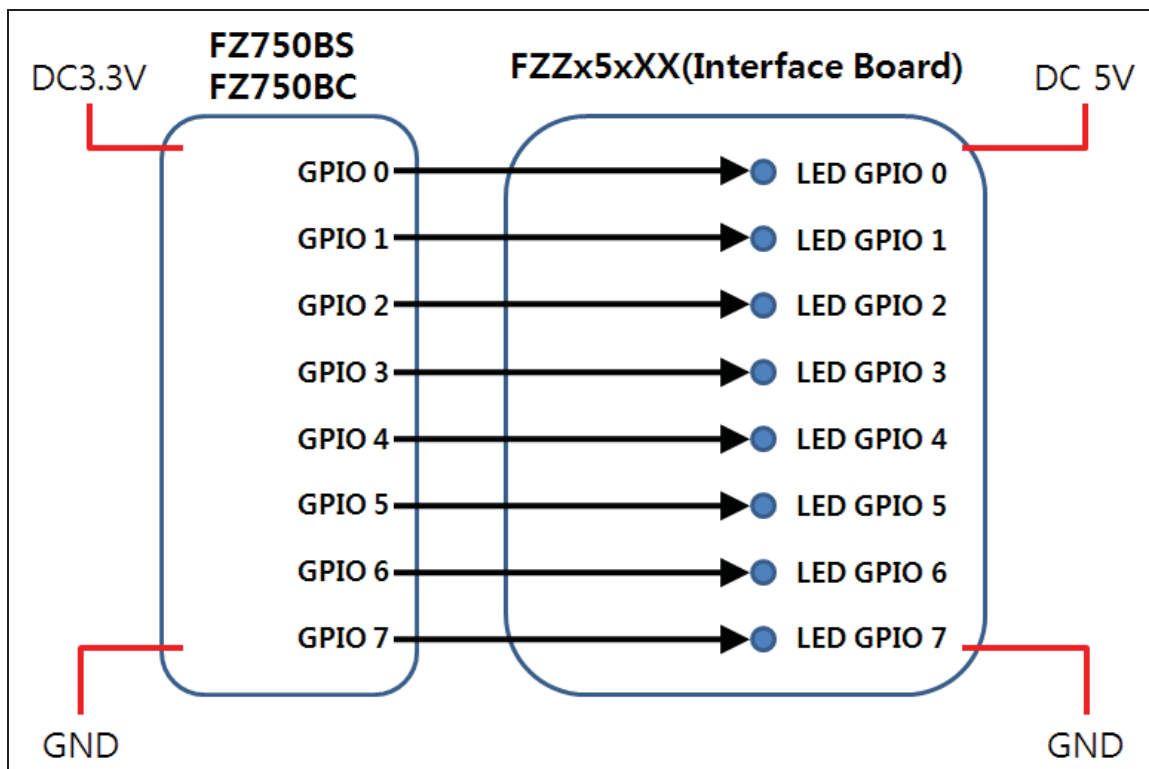

<Figure 5-5-2 connection between a GPIO(OUTPUT) of FZ750BS/FZ750BC and an Interface Board LED >

6. Set value of Product

6-1. Set value of FZ750BS/FZ750BC

<Table 6-1> shows main set values of products.

Part	Set value
Device Name	FZ750 Vx.x.x
Device Type	ROUTER
Device Channel	0B
Device Transmit Power	00
UART (baud rate–data bit–parity bit–stop bit)	115200–8–N–1
KEY option	0(Disable)
ADC Option	0(Disable)
Count Option	0(Disable)
GPIO Option	0(Disable)
Internal Time	10
ACK Option	0(Disable)
Retry Option	9
Power Mode	1
Reset Option	0(Disable)
target device Address	0000000000000000
Link Quality Option	0(Disable)
Start Message Option	1(Enable)
Debug Message Option	0(Disable)
Battery Low Option	0(Disable)
Quick Low Power Entry	0(Disable)

<Table 6-1 FZ750BS/FZ750BC set values>

To change the set values of FZ750BS/FZ750BC, use PC Software (Window HyperTerminal, Firmtech configuration program) after connecting FZ750BS/FZ750BC to PC by using a PC Interface board, or use MICOM working with AT command.

Note: Please, refer to the contents in “8. Zigbee Network Configuration” or “10. FZ750BS/FZ750BC Set-up using GUI(ZIGNET)” for further information on Set-up Modification.

7. PC Interface Board

Use an Interface Board to test Configuration and Operation Status of FZ750BS/FZ750BC.

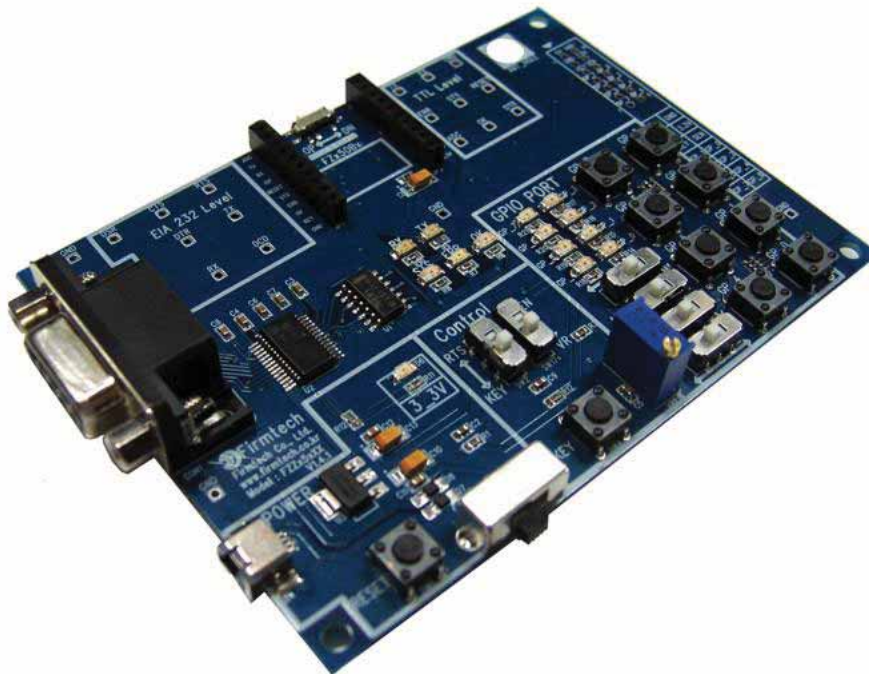

<Figure 7-1 FZ750BS/FZ750BC Interface Board>

7-1. Interface Board Description

7-1-1. USB power input terminal & power on/off switch & reset switch

- (1) Connect USB port of PC to an Interface board by using USB power cable.
- (2) The power is authorized to Interface Board and a FZ750BS/FZ750BC with the power switch turned on.
- (3) Software is reset if reset switch is pushed. (Power OFF -> ON)

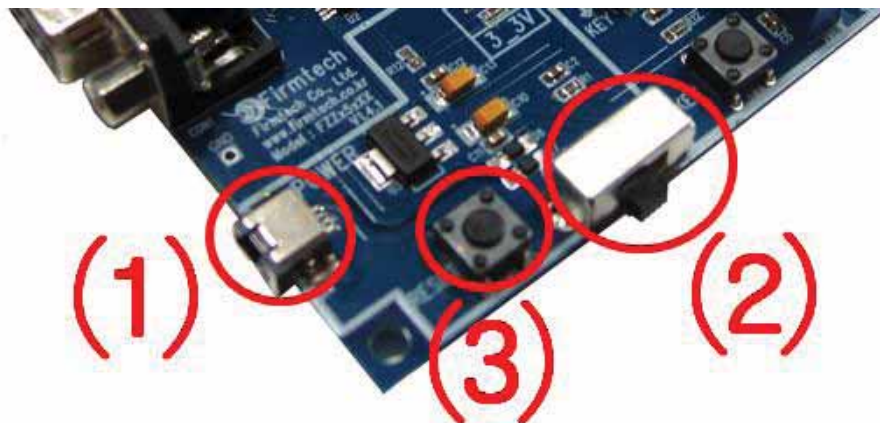

< Figure 7-1-1 USB Power Input & Power Switch & Reset switch >

7-1-2. RS232 interface terminal

- (1) Connect PC to Interface Board by using RS232 cable.
- (2) Inputting and outputting data into UART port becomes possible by using serial program of PC.
- (3) Configuration set-up of FZ750BS/FZ750BC is possible by using GUI (ZIGNET).

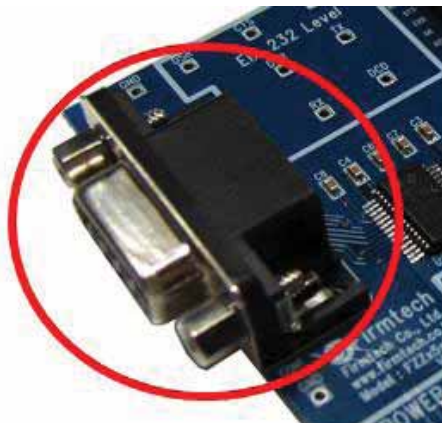

<Figure 7-1-2 RS232 Interface Terminal>

7-1-3. FZ750BS/FZ750BC connection connector

- (1) Connect Interface Board to FZ750BS/FZ750BC.
- (2) All functions of FZ750BS/FZ750BC can be used by Interface Board.
- (3) Functions of FZ750BS/FZ750BC are shown on PC.

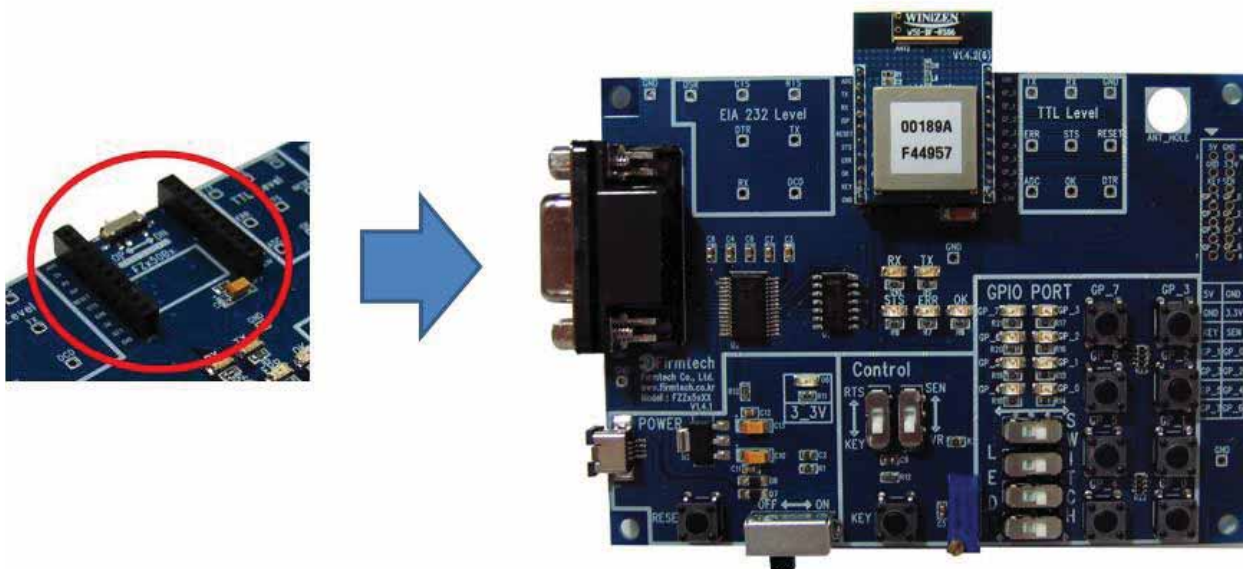

< Figure 7-1-3 FZ750BS/FZ750BC >

7-1-4. Control selection switch

(1) KEY / RTS selection switch

- ① If you set “KEY / RTS selection switch” to KEY, KEY port of FZ750BS/FZ750BC is connected to KEY switch on an Interface Board.

You can input KEY data into KEY port of FZ750BS/FZ750BC by using a KEY switch on an Interface Board.



< Figure 7-1-4-(1)-① KEY / RTS selection switch – Select KEY >

- ② If you set “KEY / RTS selection switch” to RTS, KEY port of FZ750BS/FZ750BC is connected to RTS Terminal of RS232.

You can input KEY data into KEY port by using RTS port of PC.

In this case, KEY switch on an Interface Board does not operate.



< Figure 7-1-4-(1)-② KEY / RTS selection switch – Select RTS >

(2) VR / SEN selection switch

- ① If you set “VR / SEN selection switch” to VR, ADC port of FZ750BS/FZ750BC is connected to variable resistance of an Interface Board.

You can input ADC data into ADC port of FZ750BS/FZ750BC by using the variable resistance of Interface Board.



< Figure 7-1-4-(2)-① VR / SEN selection switch – Select VR >

- ② If you set “VR / SEN selection switch” to SEN, ADC port of FZ750BS/FZ750BC is connected to extension test port on an Interface Board.

You can input ADC data into ADC port by using the extension test port of an Interface Board.
In this case, Variable Resistance of Interface Board does not operate.



< Figure 7-1-4-(2)-② VR / SEN selection switch –Select SEN >

7-1-5. KEY data Input Switch

- (1) To use “KEY data Input Switch” on an Interface Board, set “KEY / RTS selection switch” to KEY.
- (2) If you push the “KEY data Input Switch”, KEY data is inputted into KEY port of FZ750BS/FZ750BC.

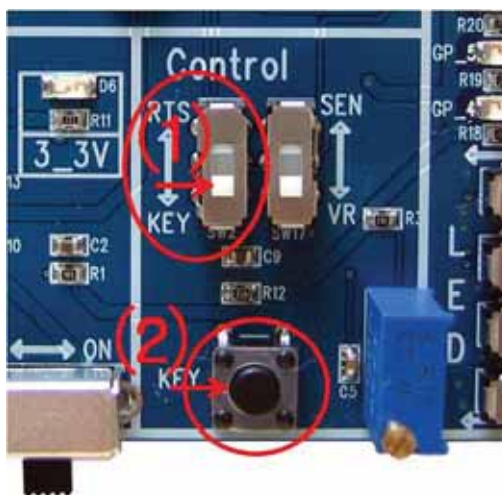

< Figure 7-1-5 Setting KEY / RTS selection switch to KEY & KEY data Input Switch >

7-1-6. ADC data Input Variable Resistance

- (1) To use “ADC data Input Variable Resistance” of an Interface Board, set “VR / SEN selection switch” to VR.
- (2) If you change the “ADC data Input Variable Resistance”, the changed ADC data is inputted into ADC port of FZ750BS/FZ750BC.



< Figure 7-1-6 Setting VR / SEN selection switch to SEN & ADC data Input Variable Resistance >

7-1-7. GPIO selection switch

(1) If you set “GPIO selection switch” to SWITCH, GPIO of FZ750BS/FZ750BC is connected to GPIO Switch on an Interface Board.

You can input GPIO data into GPIO port of FZ750BS/FZ750BC by using GPIO Switch on an Interface Board.

In this case, GPIO Option of FZ750BS/FZ750BC should be set to INTPUT(1).

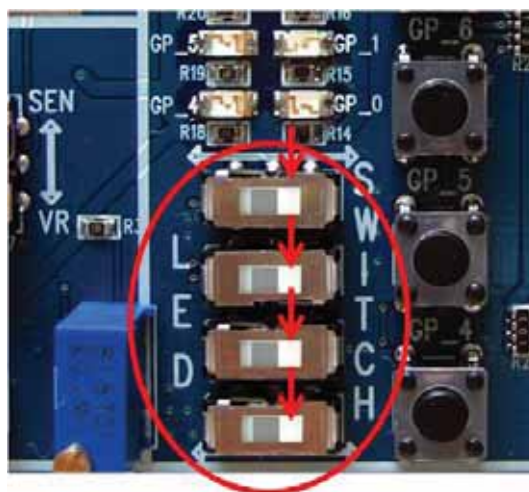

< Figure 7-1-7-(1) GPIO selection switch – Select SWITCH >

(2) If you set “GPIO selection switch” to LED, GPIO of FZ750BS/FZ750BC is connected to GPIO LED on an Interface Board.

You can check GPIO Value from FZ750BS/FZ750BC by using GPIO LED on an Interface Board.

In this case, GPIO Set-up Option of FZ750BS/FZ750BC should be set to OUTPUT (2).

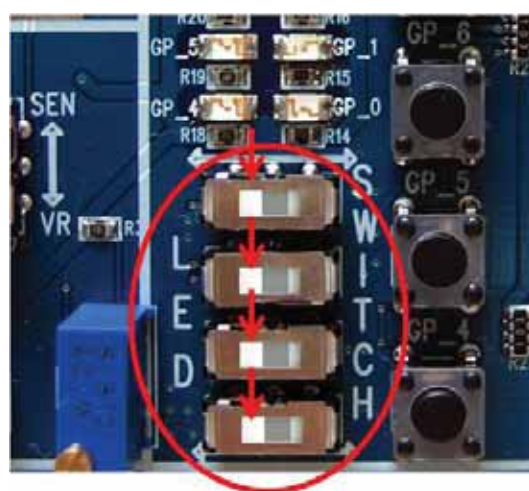

< Figure 7-1-7-(2) GPIO selection switch – Select LED >

7-1-8. GPIO Input Switch & GPIO Output LED

(1) GPIO Input Switch

- ① You can use it when you set “GPIO selection switch” on an Interface Board to switch.
- ② You can use it when you set GPIO Set-up Option of FZ750BS/FZ750BC to INPUT(1).
- ③ You can input GPIO data into GPIO port of FZ750BS/FZ750BC by using GPIO switch on an Interface Board.

(2)AT+SETGPIO1

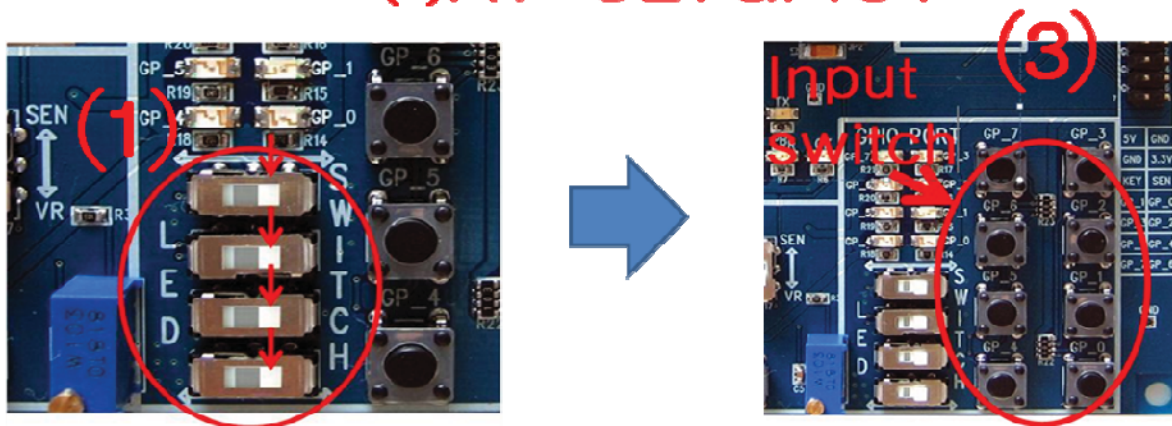

< Figure 7-1-8-(1) Setting GPIO selection switch to SWITCH & GPIO data Input switch >

(2) GPIO Output LED

- ① You can check GPIO Output with it when you set “GPIO selection switch” to LED on an Interface Board.
- ② You can use it when you set GPIO set-up Option of FZ750BS/FZ750BC to OUTPUT(2).
- ③ You can check value from GPIO port of FZ750BS/FZ750BC by using GPIO LED on an Interface Board.

(2)AT+SETGPIO2

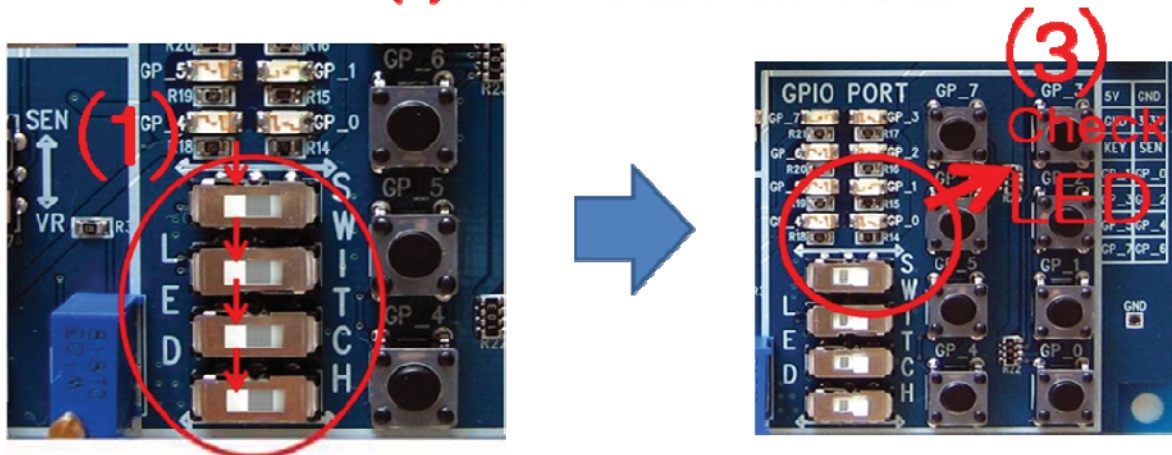

< Figure 7-1-8-(2) Setting GPIO selection switch to LED & checking GPIO data Output with LED >

7-1-9. RX / TX LED

- (1) They are connected to UART port.
- (2) They show status of UART data Input/output.
- (3) RX LED flickers when UART data is inputted.
- (4) TX LED flickers when UART data is outputted.

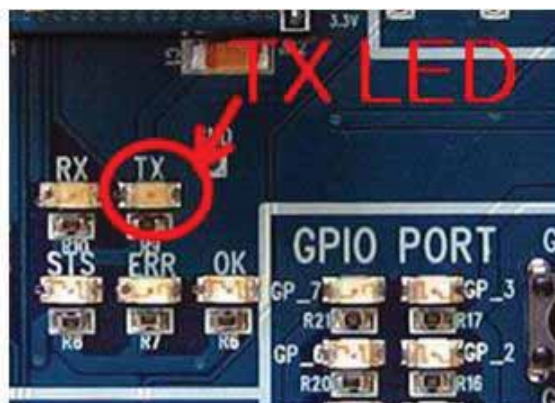
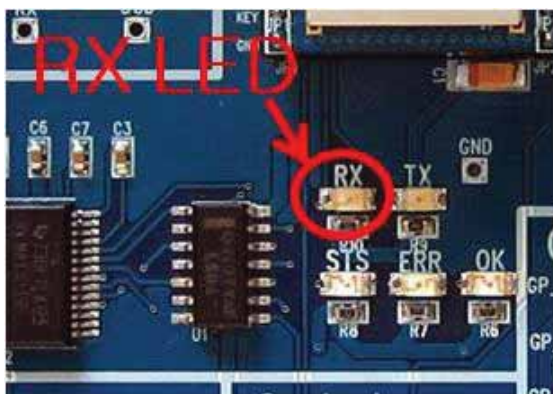

< Figure 7-1-9 RX / TX LED >

7-1-10. STS / ERR / OK LED

- (1) They are connected to STATUS / ERROR / OK port.
- (2) They show overall operation status of FZ750BS/FZ750BC.
- (3) STS LED on an Interface Board is connected to CD port of RS232 port. (RS232 port No.1)
- (4) OK LED on an Interface Board is connected to CTS port of RS232 port. (RS232 port No.8)
- (5) ERR LED on an Interface Board is connected to DSR port of RS232 port. (RS232 port NO.6)

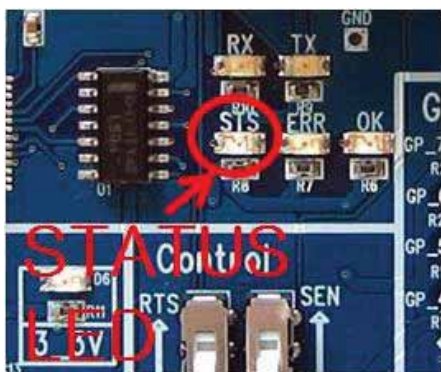

< Figure 7-1-10 STS / ERR / OK LED >

7-1-11. ISP selection switch

- (1) It is connected to ISP port of FZ750BS/FZ750BC.
- (2) It is a switch that is used when firmware is updated.
- (3) Do not set it to DN because FZ750BS/FZ750BC program can be destroyed.

Operation mode

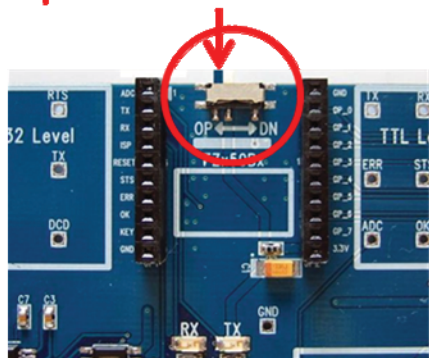

Firmware update

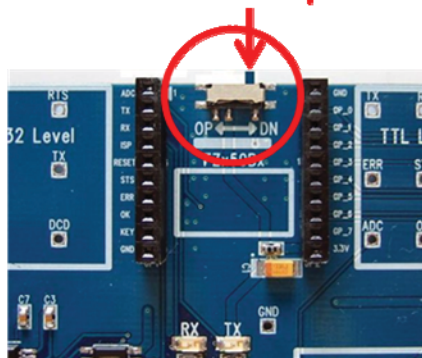

We do not recommend to change it.

< Figure 7-1-11 ISP selection switch >

7-1-12. Extension test port

- (1) It is connected to KEY / ADC / GPIO port of FZ750BS/FZ750BC.
 - (2) You can configure other forms of data Input(Output) by using the extension test port on an Interface Board.
 - (3) KEY / GPIO port of FZ750BS/FZ750BC is directly connected to the extension test port on an Interface Board.
- KEY and GPIO port can use the extension test port without additional Set-up.

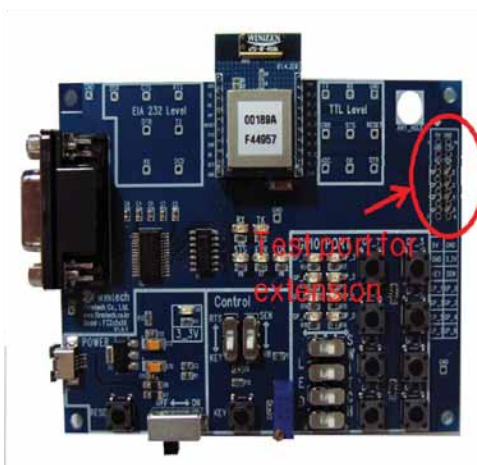

< Figure 7-1-12-① Extension test port >

(4) To use ADC port of FZ750BS/FZ750BC as extension test port of Interface Board, set “VR / SEN selection switch” to SEN.



< Figure 7-1-12-② Set-up for using ADC port as extension port >

(5) Extension port of FZ750BS/FZ750BC is used for connection with extension interface board. Extension interface board provided is vacant. 2.54mm (100mil) Headers can be used for the connection in case of need.

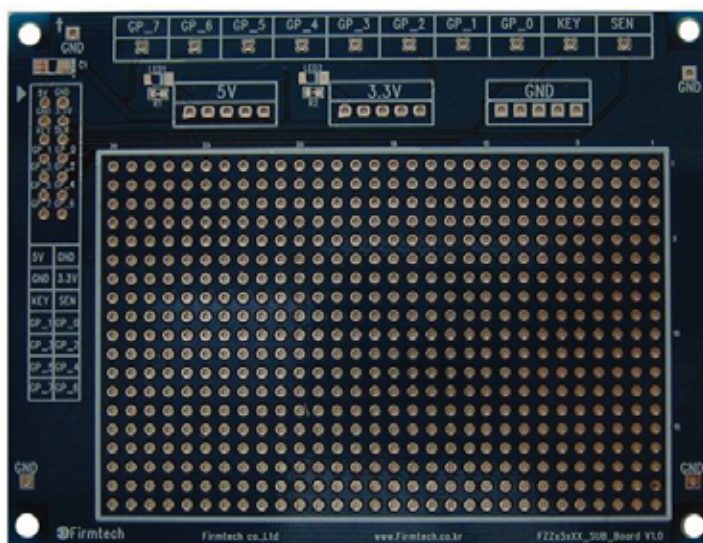

< Figure 7-1-12-③ Extension Interface Board >



<Figure 7-1-12-④ 2.54mm(100mil) 7*2 Pin Headers >

(6) Extension interface connection board is used for connection between extension port of FZ750BS/FZ750BC and extension interface board.

Extension interface connection board provided is vacant. 2.54mm (100mil) Headers can be used for the connection in case of need.

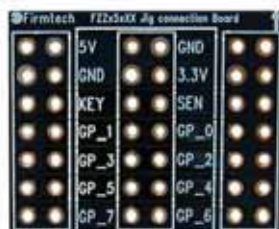

< Figure 7-1-12-⑤ A Extension Interface Connection Board >

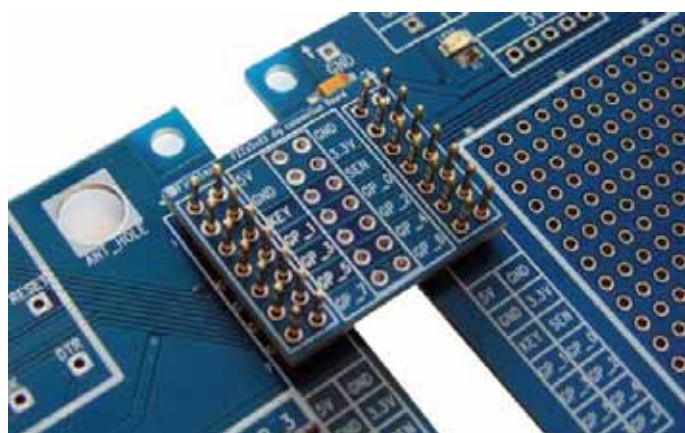

<Figure 7-1-12-⑥ A connection between Interface Board and Extension Interface Board by Extension Interface Connection Board >

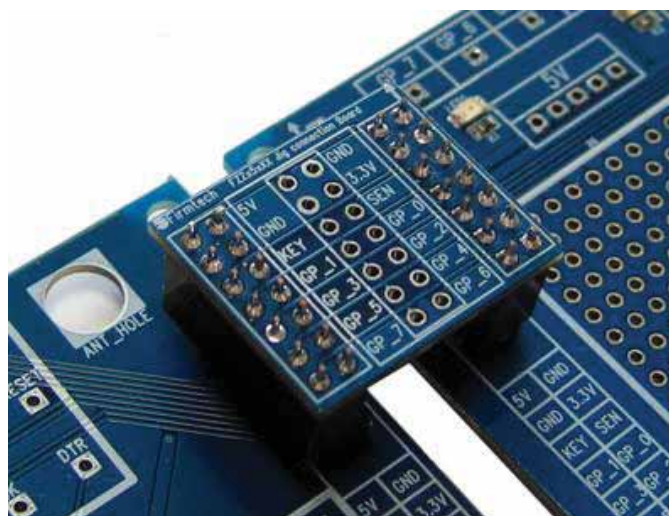

< Figure 7-1-12-⑦ A connection by 2.54mm(100mil) Headers>

(7) A space between Pins is 2.0mm(75mil).

You can use 2.54mm(100mil) of convertible Board to adjust the space between Pins.

2.54mm(100mil) of convertible Board provided is vacant, Headers can be used in case of need.



< Figure 7-1-12-⑧ 2.54mm(100mil) A Convertible Board >



< Figure 7-1-12-⑨ 2.54mm(100mil) 10*1 Pin Headers >

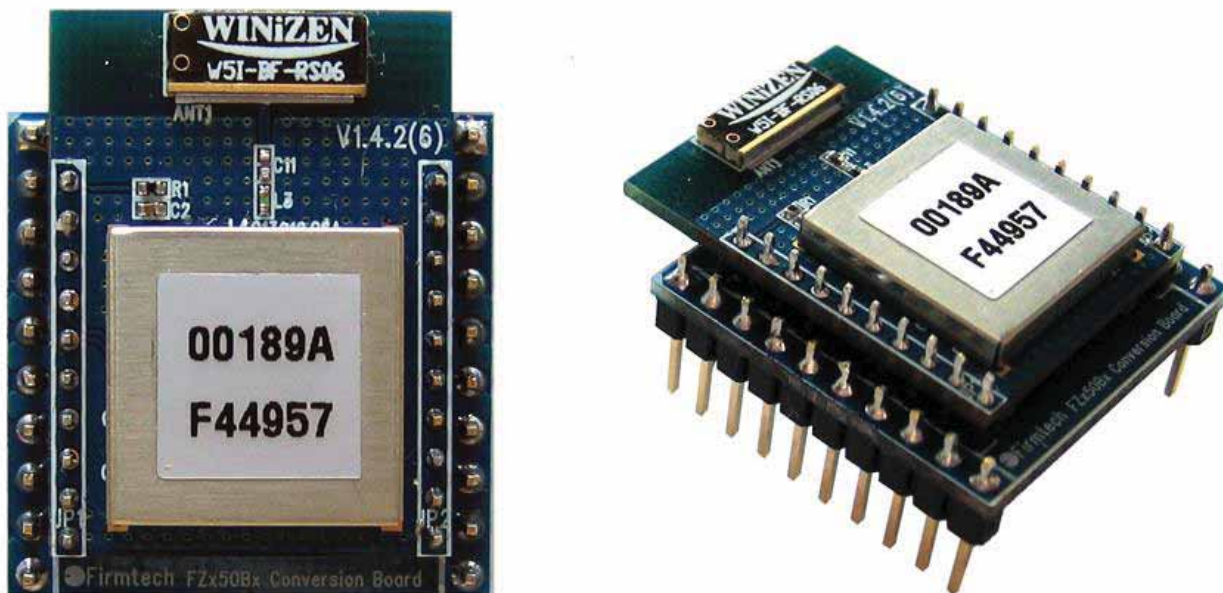

< Figure 7-1-12-⑩ 2.54mm(100mil) Mounting Convertible Board >

7-2. Check lists before mounting FZ750BS/FZ750BC on an Interface Board.

Check the following before mounting FZ750BS/FZ750BC on an Interface Board.

7-2-1. ISP selection switch

Set ISP selection switch to "OP".

7-2-2. KEY / RTS selection switch

Set KEY / RTS selection switch to "KEY".

7-2-3. VR / SEN selection switch

Set VR / SEN selection switch to "VR".

7-2-4. GPIO selection switch

In case that GPIO is used for Input, set GPIO selection switch to "SWITCH".

In case that GPIO is used for Output, set GPIO selection switch to "LED".

7-2-5. Power Input Switch

It should be turned OFF before FZ750BS/FZ750BC is mounted.

7-2-6. RS232 Connector

It is connected to PC by using RS232 Serial Cable.

7-2-7. USB Power Connector

It is connected to PC by using USB Power Cable.

※ Approve Power by connecting FZ750BS/FZ750BC to its Connector after all check lists are done.
You can use all functions FZ750BS/FZ750BC has by using an Interface Board.

8. Zigbee network Configuration

To configure the Zigbee Network, set up a FZ750BS/FZ750BC DEVICE.

The following is a procedure for FZ750BS/FZ750BC Set-up using Serial communication (HyperTerminal) Program.

The signal speed of FZ750BS/FZ750BC is basically 115200bps.

8-1. Serial Communication (Hyper Terminal) Program Execute

Select [Start]→[All Programs]→[Accessories]→[Communication]→[Hyper Terminal] in order, and then a window for Connection Set-up comes up. Put a name in the name blank, and click the OK button.

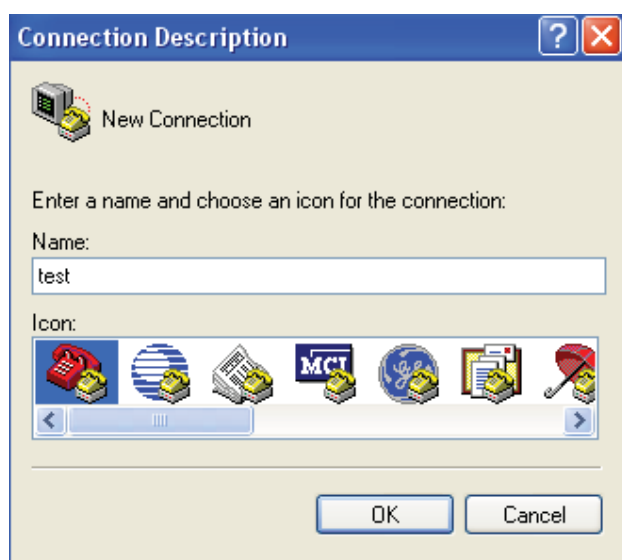

When a window for Connection target comes up, select COM ports connected to FZ750BS/FZ750BC, and click the OK button.



Select each blank as below “Bit/sec: 115200, data Bit: 8, Parity: None, Stop Bit: 1, Flow Control: None”, and click the OK button. Hyper Terminal is executed.

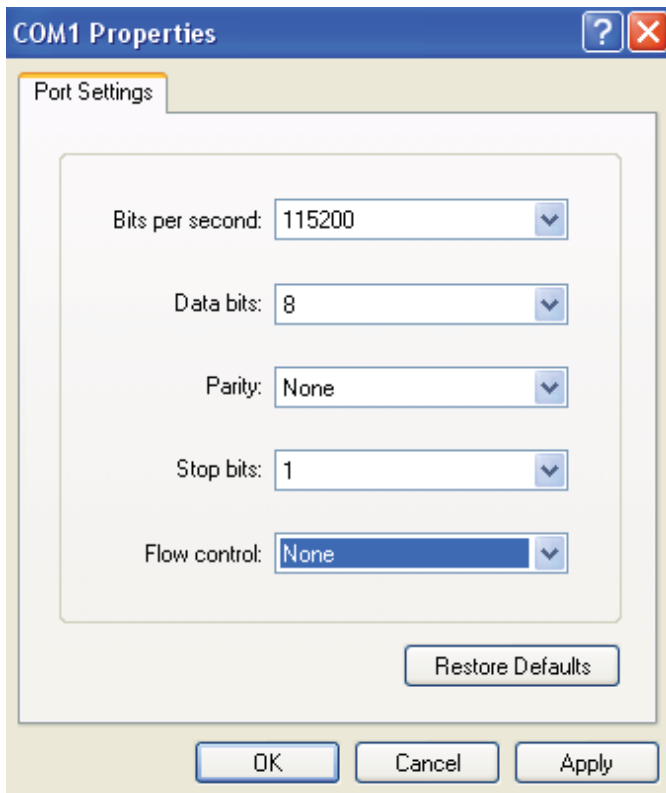

Hyper Terminal simply does not show any letters inputted.

If you check on “Display the letters inputted on the Terminal” to get to know what letters are inputted, the Recommends between FZ750BS/FZ750BC and Hyper Terminal are mixed up. Do not check this.

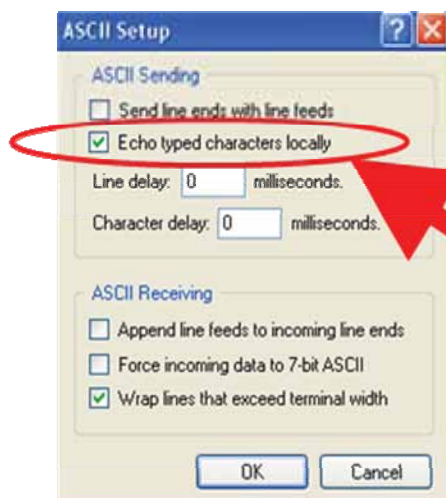

8-2. Set-up FZ750BS/FZ750BC Device Type

Zigbee Device is classified as Coordinator, Router, and End Device by objective of its operation.

There should be Coordinator in the Zigbee Network. A Coordinator should exist in a Zigbee Network.

Coordinator manages the Network in the Zigbee Network.

Router extends the Network in the Zigbee Network.

End Device participates in the zigbee Network using low power consumption.

Router and End Device are automatically participated in the Network once Coordinator configures the Zigbee Network.

Note: Please, refer to the following when you try to configure the Zigbee Network.

1. Do not turn the power of the Device set to Coordinator ON before all devices' types are set.
 2. If you already set the rest type of each Device and operate them with the Coordinator that the power is turned on, execute Factory Reset for the devices set to Coordinator and Router.
Before the Factory reset, the power of the Coordinator and the Router should be turned OFF. After the Factory reset is done, set each Device to Coordinator and Router, and turn on the power of all devices. The Zigbee Network shall be properly configured.
 3. Do not change the Device Type of FZ750BS/FZ750BC once the Zigbee Network is configured.
- ※ It is better to set Coordinator and Router again(Factory Reset) if the Device Type of FZ750BS/FZ750BC is changed after the Zigbee Network is already configured.
 - ※ See if the Zigbee Network is configured before resetting FZ750BS/FZ750BC to initial set value. The FZ750BS/FZ750BC reset automatically participates in the Zigbee Network if the Zigbee Network still exists there.

8-2-1. FZ750BS/FZ750BC End Device Set-up

(1) The Initial set value of FZ750BS/FZ750BC is ROUTER.

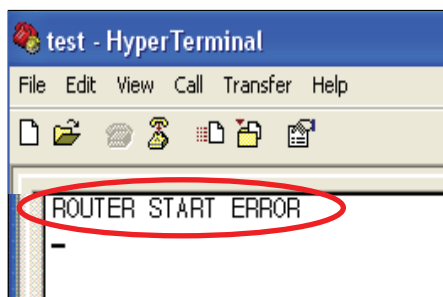

(2) Connect Device to PC, execute Hyper Terminal, and approve the power to the Device. "ROUTER START ERROR" is output through Serial port.

"ROUTER START" and "ERROR" are output.

"ROUTER START ERROR" means that The Zigbee Network Participation is failed. "ROUTER START OK" is output if the Zigbee Network is configured.

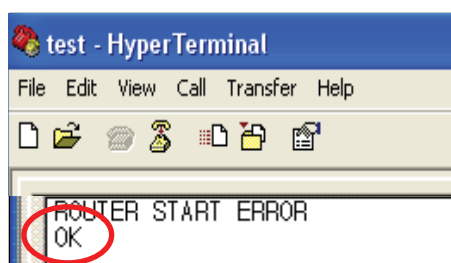

(3) Input "+++" in Hyper Terminal.

(4) If "OK" is outputted from FZ750BS/FZ750BC, AT-Command can be used from then.

If "OK" is not output even after inputting "+++", press "Enter" key and input "+++" again, or reboot the device and input "+++".

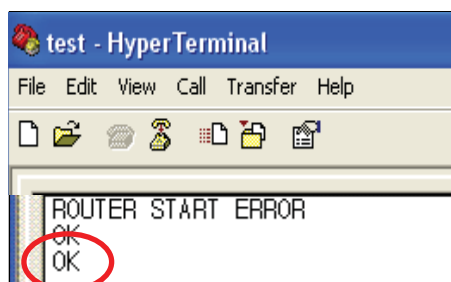

(5) After inputting "AT+SETEND" into Hyper Terminal, press Enter Key.

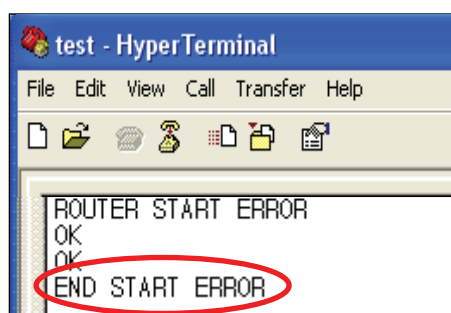

(6) If "OK" is output from FZ750BS/FZ750BC, reboot FZ750BS/FZ750BC by inputting "ATZ".

(7) "END START ERROR" is output at the moment when FZ750BS/FZ750BC is rebooted.

"END START OK" is output if the Zigbee Network is successfully configured.

(8) Now, End Device of FZ750BS/FZ750BC set-up is completed.

Turn the Power of the End Device OFF, and set other devices.

8-2-2. FZ750BS/FZ750BC Router Set-up

(1) The initial set value of Device is ROUTER.

※ The initial set value of FZ750BS/FZ750BC is ROUTER.

The following is a procedure of purposely setting Device to Router by using AT-Command.

However, Device originally operates as Router without intentional setting.

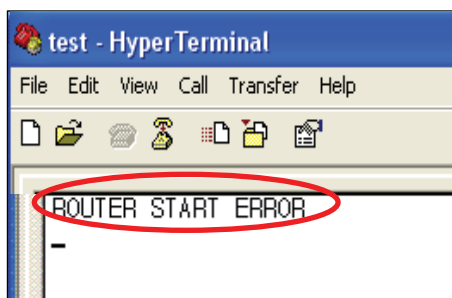

(2) Connect FZ750BS/FZ750BC to PC, execute Hyper Terminal Program, and approve the power to the FZ750BS/FZ750BC.

“ROUTER START ERROR” is output through Serial port.

“ROUTER START” and “ERROR” are output.

“ROUTER START ERROR” means that the Zigbee Network participation is failed.

“ROUTER START OK” is output if the Zigbee is successfully configured Network.

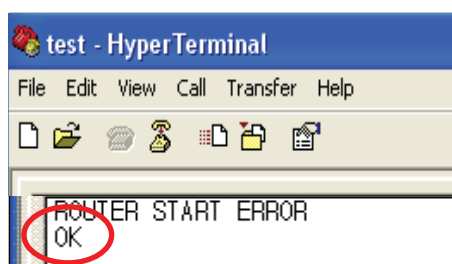

(3) Input “+++” into Hyper Terminal.

(4) If “OK” is output from FZ750BS/FZ750BC, AT-Command can be used from then.

If “OK” is not output even after inputting “+++”, press “Enter” key and input “+++” again, or reboot the device and input “+++”.

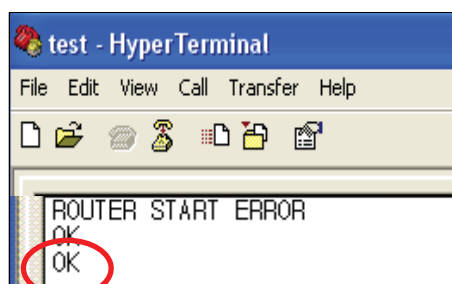

(5) Input “AT+SETROUTER” through Serial port of PC and press “Enter” key.

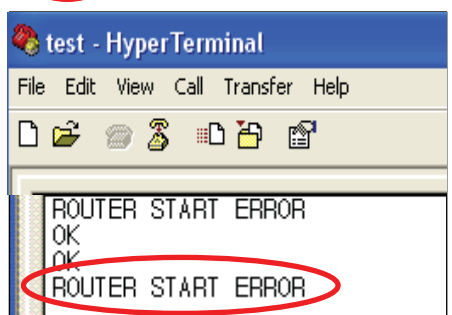

(6) If “OK” is output from FZ750BS/FZ750BC by inputting “ATZ”, reboot FZ750BS/FZ750BC.

(7) “ROUTER START ERROR” is output at the moment when FZ750BS/FZ750BC is rebooted.

“ROUTER START OK” is output if the Zigbee Network is successfully configured.

(8) Now, Router of FZ750BS/FZ750BC Set-up is completed.

Turn the Power of the Router Device OFF, and set other devices.

8-2-3. FZ750BS/FZ750BC Coordinator set-up

(1) The initial set value of FZ750BS/FZ750BC is ROUTER.

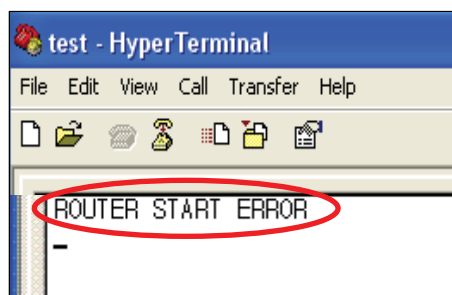

(2) Connect FZ750BS/FZ750BC to PC, execute Hyper Terminal Program, and approve the power to the FZ750BS/FZ750BC. "ROUTER START ERROR" is output through Serial port.

"ROUTER START" and "ERROR" are output.

"ROUTER START ERROR" means that the Zigbee Network participation is failed.

"ROUTER START OK" is output if the Zigbee Network is

successfully configured.

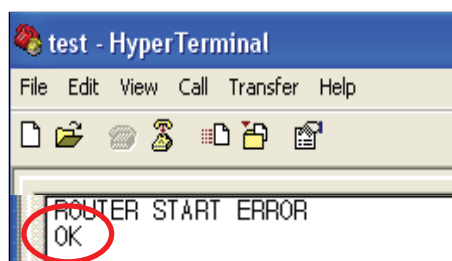

(3) Input "+++" into Hyper Terminal.

(4) If "OK" is output from FZ750BS/FZ750BC, AT-Command can be used from then.

If "OK" is not output even after inputting "+++", press "Enter" key and input "+++" again, or reboot the device and input "+++".

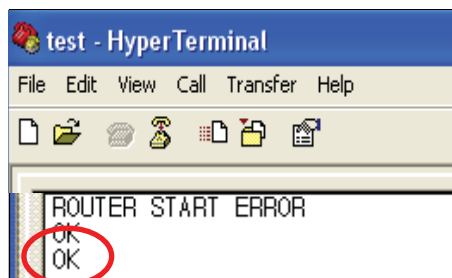

(5) Input "AT+SETCOORD" through Serial port of PC and press "Enter" key

(6) If "OK" is output from FZ750BS/FZ750BC by inputting "ATZ", reboot FZ750BS/FZ750BC.

(7) "COORD START OK" is output at the moment when FZ750BS/FZ750BC is rebooted.

(8) Now, Coordinator of FZ750BS/FZ750BC Set-up is completed, and the Zigbee Network is successfully configured.

Turn the Power of the Coordinator Device OFF, and set other devices.

8-3. The Zigbee Network Configuration using FZ750BS/FZ750BC

Try to configure the Zigbee Network after setting the Type for each Device.

8-3-1. The Zigbee Network configuration

Coordinator leads the Zigbee Network Configuration.

Coordinator manages the Zigbee Network.

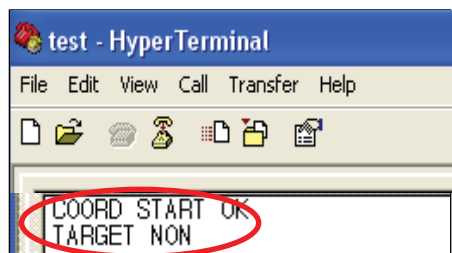

(1) Turn the power of the Device set to Coordinator ON.

(2) "COORD START OK" is output.

"COORD START OK" and "TARGET NON" are output.

"TARGET NON" means that FZ750BS/FZ750BC has yet to set its target device.

(3) Zigbee Network is configured by Coordinator.

(4) From then, Zigbee Network Participation and Extension is possible by Router and End Device.

(5) Coordinator can transmit Data.

8-3-2. Zigbee Network Extension

Router performs the Zigbee Network Extension.

Communication distance and route can be extended because of the Zigbee Network Extension by Router.

The number of End Device which participates in the Zigbee Network can be increased because of the Zigbee Network Extension by Router.

Router also transmits data in the Zigbee Network, as well.

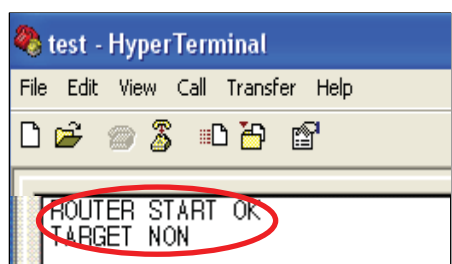

(1) Turn the Power of the Device set to Router ON.

(2) "ROUTER START OK" is output.

"ROUTER START OK" and "TARGET NON" are output.

"TARGET NON" means that FZ750BS/FZ750BC has yet to set its target device.

If "ROUTER START ERROR" is output, which means that no

Zigbee Network is around, reset the Device or check if the Coordinator's status is okay.

(3) Router participates in the Zigbee Network and extends the Zigbee Network.

(4) Router can transmit Data.

8-3-3. Zigbee Network Participation

End Device participates in the Zigbee Network.

End Device performs data transmission in the Zigbee Network.

End Device supports Low power consumption mode.

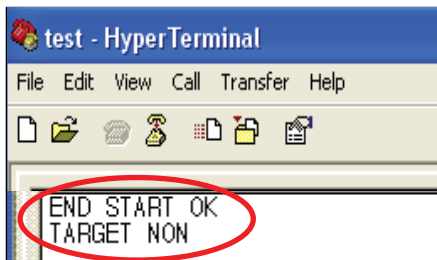

(1) Turn the Power of the Device set to End Device ON.

(2) "END START OK" is output.

"END START OK" and "TARGET NON" are output.

"TARGET NON" means that FZ750BS/FZ750BC has yet to set its target device.

If "END START ERROR" is output, which means that no Zigbee Network is around, reset the Device or check if the Coordinator's status is okay.

(3) End Device participates in the Zigbee Network, and is ready to transmit Data.

9. FZ750BS/FZ750BC data transmission

Data transmission is possible by Devices which set its target devices after The Zigbee Network Configuration.

Data types for data transmission are UART/ADC/KEY/COUNT/GPIO.

If data type for transmission is set to UART, A Device transmits UART data to its target device.

-Press "Enter" key after inputting UART Data.

If data type for transmission is set to ADC, A Device transmits ADC data to its target device repeatedly because the Device reads ADC port every certain time.

-Check the Internal time with a command "AT+GETTMR"

If data type for transmission is set to KEY, A Device transmits KEY data to its target device.

If enabling COUNT data transmission is set after enabling ADC data transmission is set, the Device transmits COUNT data instead of ADC data to its target device every certain time.

If GPIO Use Option is set to INPUT after enabling KEY data transmission is set, the Device transmits GPIO INPUT data instead of KEY data to its target device.

If GPIO Use Option is set to INPUT after enabling ADC data transmission is set, the Device transmits GPIO INPUT data instead of ADC data to its target device every certain time.

9-1. Set-up Transmission data Type

9-1-1. UART set-up

UART(TTL Level Serial Data) data transmission is possible by using FZ750BS/FZ750BC. FZ750BS/FZ750BC supports UART communication. No additional setting is required. The signal speed of FZ750BS/FZ750BC is normally 115200bps. You can input Serial data by using UART port of FZ750BS/FZ750BC.

9-1-2. ADC set-up

ADC (Analog to Digital) data transmission is possible by using FZ750BS/FZ750BCADC. ADC transmission option is basically set to be disabled (0). You can input ADC data by using ADC port of FZ750BS/FZ750BC Set to ADC transmission option to be enabled as below.

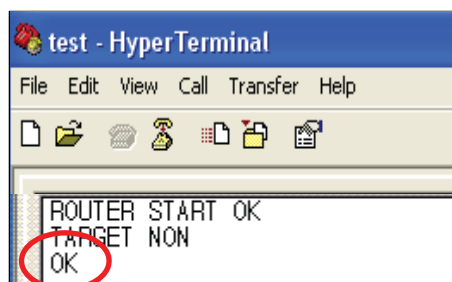

(1) Input “+++” through the Serial port of PC.
 (2)AT-Command can be used after “OK” is output from FZ750BS/FZ750BC.
 If “OK” is not output from FZ750BS/FZ750BC even after you input “+++”, press Enter Key and input “+++” again, or reboot the Device.

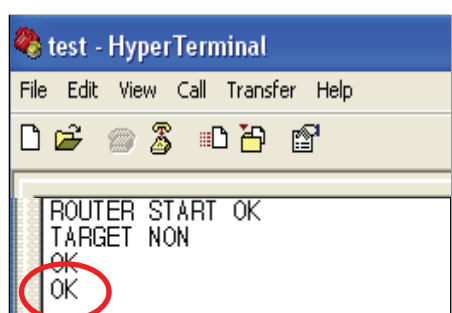

(3) Input “AT+SETADC1” through Serial port of PC and press “Enter” key.
 (4) “OK” is output from FZ750BS/FZ750BC, which means that ADC transmission option is set to be enabled (1).

If ADC transmission option of FZ750BS/FZ750BC is enabled (1), the Device reads ADE port every certain time(check the Internal time with a command “AT+GETTMR”), change Analog data to Digital Value, and transmits the value to its target device.

The Internal time of FZ750BS/FZ750BC is basically set to 10seconds. FZ750BS/FZ750BC reads ADC port every 10 seconds unless you intentionally change the internal time.