

# USER'S MANUAL SMOKE AND FIRE\* ALARM

**First Alert®**

**BATTERY POWERED  
PHOTOELECTRIC SMOKE ALARM  
WITH SILENCE AND ESCAPE LIGHT®**

**CONFORMS TO  
UL STD 217**  
Model P900E

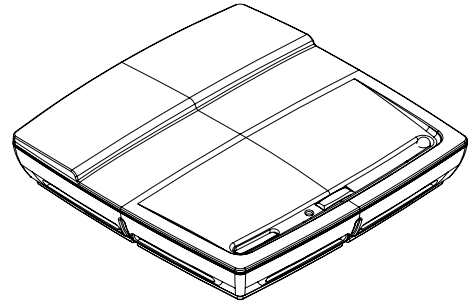

**IMPORTANT! PLEASE READ CAREFULLY AND SAVE.**

This user's manual contains important information about your Smoke Alarm's operation. If you are installing this Smoke Alarm for use by others, you must leave this manual—or a copy of it—with the end user.

## INTRODUCTION

Thank you for choosing First Alert® for your Smoke Alarm needs. You have purchased a state of the art Smoke Alarm designed to provide you with early warning of a fire. Please take the time to read this manual and make the Smoke Alarm an integral part of your family's safety plan.

Key Features of the P900E Smoke Alarm:

**Photoelectric Sensing Technology:** Photoelectric Sensors are generally more sensitive than ionization sensors in detecting smoldering fires which commonly occur in couches or bedding.

**OptiPath 360 Technology™:** Patented technology provides 360° of direct access to the smoke sensor.

**Single Test/Silence Button:** Allows you to test the alarm or silence

nuisance alarms. Testing the Alarm assures you that the unit is functioning correctly and ready to protect you and your family. The Alarm can be silenced for up to 15 minutes in the event of a nuisance alarm.

**Escape Light®:** Bright LED escape light activates when this unit goes into alarm to illuminate your path to safety.

**Battery Door with "battery missing" lockout:**

The battery door will not close if a battery has not been inserted thus alerting you that the unit is not powered and not operating.

**Low battery warning:** The Alarm will sound a "chirp" once per minute when the battery needs to be replaced.

**Blinking Power Indicator:** Confirms that the Smoke Alarm is receiving power.

**All First Alert® Smoke Alarms conform to regulatory requirements, including UL217 and are designed to detect particles of combustion. Smoke particles of varying number and size are produced in all fires.**

**i** Ionization technology is generally more sensitive than photoelectric technology at detecting small particles, which tend to be produced in greater amounts by flaming fires, which consume combustible materials rapidly and spread quickly. Sources of these fires may include paper burning in a wastebasket, or a grease fire in the kitchen.

**P** Photoelectric technology is generally more sensitive than ionization technology at detecting large particles, which tend to be produced in greater amounts by smoldering fires, which may smolder for hours before bursting into flame. Sources of these fires may include cigarettes burning in couches or bedding.

**For maximum protection, use both types of Smoke Alarms on each level and in every bedroom of your home.**

## FIRE SAFETY TIPS

Follow safety rules and prevent hazardous situations: 1) Use smoking materials properly. Never smoke in bed. 2) Keep matches or lighters away from children; 3) Store flammable materials in proper containers; 4) Keep electrical appliances in good condition and don't overload electrical circuits; 5) Keep stoves, barbecue grills, fireplaces and chimneys grease- and debris-free; 6) Never leave anything cooking on the stove unattended; 7) Keep portable heaters and open flames, like candles, away from flammable materials; 8) Don't let rubbish accumulate.

Keep alarms clean, and test them weekly. Replace alarms immediately if they are not working properly. Smoke Alarms that do not work cannot alert you to a fire. Keep at least one working fire extinguisher on every floor, and an additional one in the kitchen. Have fire escape ladders or other reliable means of escape from an upper floor in case stairs are blocked.



© 2015 BRK Brands, Inc. All rights reserved. Distributed by BRK Brands, Inc. First Alert® is registered trademark of The First Alert Trust  
3901 Liberty Street Road, Aurora, IL 60504-8122 Consumer Affairs: (800) 323-9005 • www.firstalert.com www.brkelectronics.com • 2/15  
Printed in Mexico • M08-0406-010

Installed on	Replace by
_____	_____

## BEFORE YOU INSTALL THIS SMOKE ALARM

**IMPORTANT!** Read “Recommended Locations for Smoke Alarms” and “Locations to Avoid for Smoke Alarms” before beginning. This unit monitors the air, and when smoke reaches its sensing chamber, it alarms. It can give you more time to escape before fire spreads. This unit can **ONLY** give an early warning of developing fires if it is installed, maintained and located where smoke can reach it, and where all residents can hear it, as described in this manual. This unit will not sense gas, heat, or flame. It cannot prevent or extinguish fires.

**Understand The Different Type of Smoke Alarms:** Battery powered or electrical? Different Smoke Alarms provide different types of protection. See “About Smoke Alarms” for details.

**Know Where To Install Your Smoke Alarms:** Fire Safety Professionals recommend at least one Smoke Alarm on every level of your home, in every bedroom, and in every bedroom hallway or separate sleeping area. See “Recommended Locations For Smoke Alarms” and “Locations To Avoid For Smoke Alarms” for details.

**Know What Smoke Alarms Can and Can’t Do:** A Smoke Alarm can help alert you to fire, giving you precious time to escape. It can only sound an alarm once smoke reaches the sensor. See “Limitations of Smoke Alarms” for details.

**Check Your Local Building Codes:** This Smoke Alarm is designed to be used in a typical single-family home. It alone will not meet requirements for boarding houses, apartment buildings, hotels or motels. See “Special Compliance Considerations” for details.

## HOW TO INSTALL THIS SMOKE ALARM

### TOOLS YOU WILL NEED:

**THIS UNIT IS DESIGNED TO BE MOUNTED ON THE CEILING, OR ON THE WALL IF NECESSARY.**

- Pencil
- Drill with 3/16” (5 mm) drill bit
- Standard flathead screwdriver
- Hammer

### THE PARTS OF THIS SMOKE ALARM

1. Test/Silence button
2. Power indicator light and alarm indicator
3. LED Escape Light®

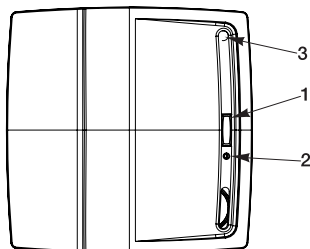

1. Mounting bracket
2. Mounting slots
3. Battery door, install 9V battery here

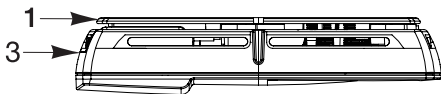
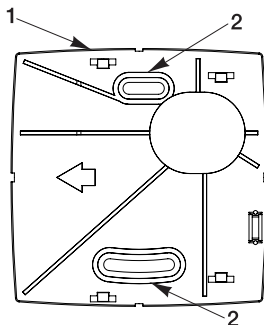

**NOTE:** Be sure to mount the product in the orientation specified in the next steps as this provides the most stability for mounting the product to the wall or ceiling.

### FOLLOW THESE SIMPLE STEPS

1. Turn alarm upside down so the circular shape is located in the upper left corner of the alarm.
2. Slide mounting bracket to the left and lift to separate it from the base.
3. Hold the mounting bracket against the ceiling (or wall) so the arrow located on the mounting plate is pointing to the left. (The circular shape will now be in upper right-hand corner). Trace around the insides of the mounting slots.
4. Put the unit where it won't get covered with dust when you drill the mounting holes.
5. Using a 3/16” (5 mm) drill bit, drill a hole through the center of the oval outlines you traced in step #3.
6. Insert the plastic screw anchors (in the plastic bag with screws) into the holes. Tap the screw anchors gently with a hammer, if necessary, until they are flush with the ceiling or wall.
7. Attach the mounting bracket to the ceiling or wall.
8. **Install the battery (included).** Open the battery door. Match the terminals on the ends of the battery with the terminals on the unit. Match “+” to “+” and “-” to “-.” Push the battery in until it snaps securely and cannot be shaken loose. If the battery is not snapped in completely, the unit cannot receive battery power.
9. Attach the Smoke Alarm to the mounting bracket. Line up the arrow on the back of the unit to the arrow on the mounting bracket. When the units are lined up, slide the alarm to the right until it snaps into place.

**NOTE:** Once the Smoke Alarm is snapped onto the mounting bracket, you can rotate the Smoke Alarm to adjust the alignment.

10. Test the Smoke Alarm. See “Weekly Testing.”

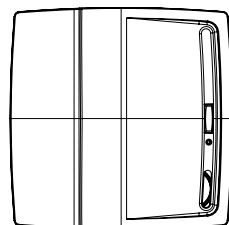
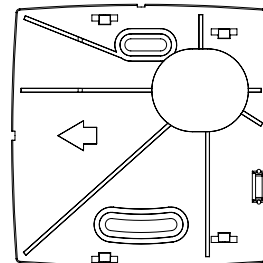
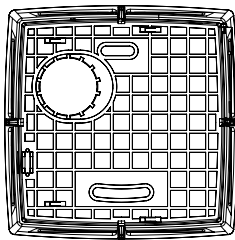
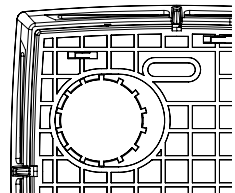

## WEEKLY TESTING

### ⚠ WARNING!

- **NEVER** use an open flame of any kind to test this unit. You might accidentally damage or set fire to the unit or to your home. The built-in test switch accurately tests the unit's operation as required by Underwriters Laboratories, Inc. (UL).
- If the Alarm ever fails to test properly, replace it immediately. Products under warranty may be returned to the manufacturer for replacement. See "Limited Warranty" for details.
- **DO NOT** stand close to the alarm when the horn is sounding. Exposure at close range may be harmful to your hearing. When testing, step away when horn starts sounding.

It is important to test this unit every week to make sure it is working properly. Using the Test/Silence button is the recommended way to test this Smoke Alarm. Press and hold the Test/Silence button on the cover of the unit until the alarm sounds and the Escape Light® turns on (the unit may continue to alarm for a few seconds after you release the button). If it does not alarm, make sure the unit is receiving power and test it again. If it still does not alarm, replace it immediately. During testing you will hear a loud, repeating horn pattern: 3 beeps, pause, 3 beeps, pause. The Escape Light® will turn on. LED flashes once every second.

---

## REGULAR MAINTENANCE

This unit has been designed to be as maintenance free as possible, but there are a few simple things you must do to keep it working properly.

- Test it at least once a week.
- Clean the Smoke Alarm at least once a month; gently vacuum off any dust using your household vacuum's soft brush attachment, and test the Smoke Alarm after cleaning. Never use water, cleaners or solvents since they may damage the unit.
- If the Smoke Alarm becomes contaminated by excessive dirt, dust and/or grime, and cannot be cleaned to avoid unwanted alarms, replace the unit immediately.
- Relocate the unit if it sounds frequent unwanted alarms. See "Locations to Avoid For Smoke Alarms" for details.
- When the battery becomes weak, the Smoke Alarm unit will "chirp" approximately once a minute (the low battery warning). This low battery warning should last for up to 7 days, but you should replace the battery immediately to continue your protection.

**CHOOSING A REPLACEMENT BATTERY:** Your Smoke Alarm requires one standard 9V battery. The following batteries are acceptable as replacements: Duracell MN1604, (Ultra) MX1604; Energizer 522. You may also use a Lithium battery like the Ultralife U9VL-J-P for longer service life between battery changes. **These batteries are available at many local retail stores.**

### ⚠ WARNING!

- **Always use the exact batteries specified by this User's Manual. DO NOT use rechargeable batteries. Clean the battery contacts and also those of the device prior to battery installation. Install batteries correctly with regard to polarity (+ and -).**
- **Please dispose of or recycle used batteries properly, following any local regulations. Consult your local waste management authority or recycling organization to find an electronics recycling facility in your area. DO NOT DISPOSE OF BATTERIES IN FIRE. BATTERIES MAY EXPLODE OR LEAK.**

### ⚠ WARNING!

- **Keep battery out of reach of children. In the event a battery is swallowed, immediately contact your poison control center, your physician, or the National Battery Ingestion hotline at 202-625-3333 as serious injury may occur.**

### IMPORTANT!

Actual service life depends on the Smoke Alarm and the environment in which it is installed. All the batteries specified above are acceptable replacement batteries for this unit. Regardless of the manufacturer's suggested battery life, you **MUST** replace the battery immediately once the unit starts "chirping" (the "low battery warning").

---

## IF THIS SMOKE ALARM SOUNDS

### RESPONDING TO AN ALARM

During an alarm, you will hear a loud, repeating horn pattern: 3 beeps, pause, 3 beeps, pause. The Escape Light® will turn on. LED flashes once every second.

### ⚠ WARNING!

- If the unit alarms get everyone out of the house immediately.
- If the unit alarms and you are not testing the unit, it is warning you of a potentially dangerous situation that requires your immediate attention. NEVER ignore any alarm. Ignoring the alarm may result in injury or death.
- Never remove the batteries from a battery operated Smoke Alarm to stop an unwanted alarm (caused by cooking smoke, etc.). Removing batteries disables the alarm so it cannot sense smoke, and removes your protection. Instead open a window or fan the smoke away from the unit. The alarm will reset automatically.

## WHAT TO DO IN CASE OF FIRE

- Don't panic; stay calm. Follow your family escape plan.
- Get out of the house as quickly as possible. Don't stop to get dressed or collect anything.
- Feel doors with the back of your hand before opening them. If a door is cool, open it slowly. Don't open a hot door. Keep doors and windows closed, unless you must escape through them.
- Cover your nose and mouth with a cloth (preferably damp). Take short, shallow breaths.
- Meet at your planned meeting place outside your home, and do a head count to make sure everybody got out safely.
- Call the Fire Department as soon as possible from outside. Give your address, then your name.
- Never go back inside a burning building for any reason.
- Contact your Fire Department for ideas on making your home safer.

**⚠ WARNING!** Alarms have various limitations. See "Limitations of Smoke Alarms" for details.

## USING THE SILENCE FEATURE

The Silence Feature can temporarily quiet an unwanted alarm for up to 15 minutes. To use this feature, press the Test/Silence button on the cover. **If the unit will not silence and no heavy smoke is present, or if it stays in silence mode continuously, it should be replaced immediately.** The LED will flash every 10 seconds while in silence.

**⚠ WARNING!** The Silence Feature does not disable the unit—it makes it temporarily less sensitive to smoke. For your safety, if smoke around the unit is dense enough to suggest a potentially dangerous situation, the unit will stay in alarm or may re-alarm quickly. If you do not know the source of the smoke, do not assume it is an unwanted alarm. Not responding to an alarm can result in property loss, injury, or death.

## IF YOU SUSPECT A PROBLEM

Smoke Alarms may not operate properly because of dead, missing or weak batteries, a build-up of dirt, dust or grease on the Smoke Alarm cover, or installation in an improper location. Clean the Smoke Alarm as described in "Regular Maintenance," and install a fresh battery, then test the Smoke Alarm again. If it fails to test properly when you use the test button, or if the problem persists, replace the Smoke Alarm immediately.

- If you hear a "chirp" about once a minute, replace the battery.
- If you experience frequent non-emergency alarms (like those caused by cooking smoke), try relocating the Smoke Alarm.
- If the alarm sounds when no smoke is visible, try cleaning or relocating the Smoke Alarm. The cover may be dirty.
- If the alarm does not sound during testing, try installing a new battery, and make sure it is snapped in securely.

**Do not try fixing the Alarm yourself – this will void your warranty!**

If the Smoke Alarm is still not operating properly, and it is still under warranty, please see "How to Obtain Warranty Service" in the Limited Warranty.

## RECOMMENDED LOCATIONS FOR SMOKE ALARMS

**INSTALLING SMOKE ALARMS IN SINGLE-FAMILY RESIDENCES** The National Fire Protection Association (NFPA), recommends one Smoke Alarm on every floor, in every sleeping area, and in every bedroom. In new construction, the Smoke Alarms must be AC powered and interconnected. See "Agency Placement Recommendations" for details. For additional coverage, it is recommended that you install a Smoke Alarm in all rooms, halls, storage areas, finished attics, and basements, where temperatures normally remain between 40° F (4.4° C) and 100° F (37.8° C). Make sure no door or other obstruction could keep smoke from reaching the Smoke Alarms.

### MORE SPECIFICALLY, INSTALL SMOKE ALARMS:

- On every level of your home, including finished attics and basements.
- Inside every bedroom, especially if people sleep with doors closed.
- In the hall near every sleeping area. If your home has multiple sleeping areas, install a unit in each. If a hall is over 40 feet (12 meters) long, install an Alarm at each end.
- At the top of the first-to-second floor stairway, and at bottom of basement stairway.

**IMPORTANT!** Specific requirements for Smoke Alarm installation vary from state to state and from region to region. Check with your local Fire Department for current requirements in your area. **It is recommended AC or AC/DC units be interconnected for added protection.**

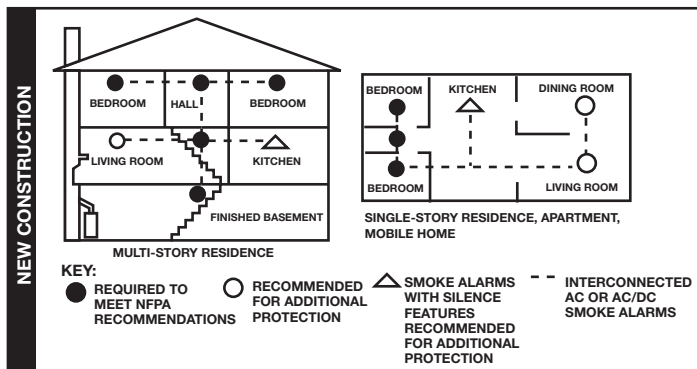
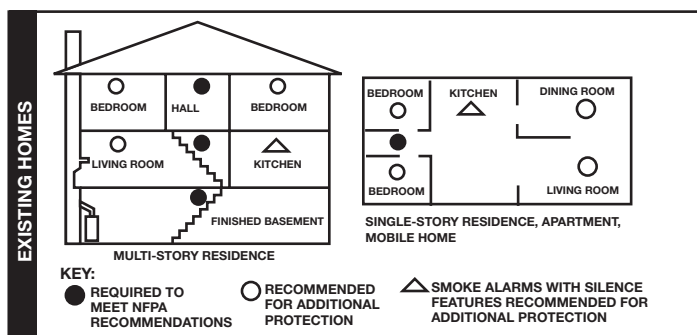

## AGENCY PLACEMENT RECOMMENDATIONS

**NFPA 72 CHAPTER 29** "For your information, the **National Fire Alarm and Signaling Code**, NFPA 72, reads as follows:"

### 29.5.1\* REQUIRED DETECTION.

**29.5.1.1\*** Where required by other governing laws, codes, or standards for a specific type of occupancy, approved single and multiple-station smoke alarms shall be installed as follows:

- (1)\*In all sleeping rooms and guest rooms
- (2)\*Outside of each separate dwelling unit sleeping area, within 21 ft (6.4 m) of any door to a sleeping room, with the distance measured along a path of travel
- (3) On every level of a dwelling unit, including basements
- (4) On every level of a residential board and care occupancy (small facility), including basements and excluding crawl spaces and unfinished attics
- (5)\*In the living area(s) of a guest suite
- (6) In the living area(s) of a residential board and care occupancy (small facility)

(Reprinted with permission from NFPA 72®, National Fire Alarm and Signaling Code Copyright © 2010 National Fire Protection Association, Quincy, MA 02269. This reprinted material is not the complete and official position of the National Fire Protection Association, on the referenced subject which is represented only by the standard in its entirety), (National Fire Alarm and Signaling Code® and NFPA 72® are registered trademarks of the National Fire Protection Association, Inc., Quincy, MA 02269).

**CALIFORNIA STATE FIRE MARSHAL (CSFM)** Early warning detection is best achieved by the installation of fire detection equipment in all rooms and areas of the household as follows: A Smoke Alarm installed in each separate sleeping area (in the vicinity, but outside bedrooms), and Heat or Smoke Alarms in the living rooms, dining rooms, bedrooms, kitchens, hallways, finished attics, furnace rooms, closets, utility and storage rooms, basements, and attached garages.

---

## LOCATIONS TO AVOID FOR SMOKE ALARMS

**FOR BEST PERFORMANCE, IT IS RECOMMENDED YOU AVOID INSTALLING SMOKE ALARMS IN THESE AREAS:**

- Where combustion particles are produced. Combustion particles form when something burns. Areas to avoid include poorly ventilated kitchens, garages, and furnace rooms. Keep units at least 20 feet (6 meters) from the sources of combustion particles (stove, furnace, water heater, space heater) if possible. In areas where a 20-foot (6-meter) distance is not possible – in modular, mobile, or smaller homes, for example – it is recommended the Smoke Alarm be placed as far from these fuel-burning sources as possible. The placement recommendations are intended to keep these Alarms at a reasonable distance from a fuel-burning source, and thus reduce "unwanted" alarms. Unwanted alarms can occur if a Smoke Alarm is placed directly next to a fuel-burning source. Ventilate these areas as much as possible.
- In air streams near kitchens. Air currents can draw cooking smoke into the sensing chamber of a Smoke Alarm near the kitchen.
- In very damp, humid or steamy areas, or directly near bathrooms with showers. Keep units at least 10 feet (3 meters) away from showers, saunas, dishwashers, etc.
- Where the temperatures are regularly below 40° F (4.4° C) or above 100° F (37.8° C), including unheated buildings, outdoor rooms, porches, or unfinished attics or basements.
- In very dusty, dirty, or greasy areas. Do not install a Smoke Alarm directly over the stove or range. Keep laundry room Smoke Alarms free of dust or lint.
- Near fresh air vents, ceiling fans, or in very drafty areas. Drafts can blow smoke away from the unit, preventing it from reaching the sensing chamber.
- In insect infested areas. Insects can clog openings to the sensing chamber and cause unwanted alarms.
- Less than 12 inches (305mm) away from fluorescent lights. Electrical "noise" can interfere with the sensor.
- In "dead air" spaces. "Dead air" spaces may prevent smoke from reaching the Smoke Alarm.

### AVOIDING DEAD AIR SPACES

"Dead air" spaces may prevent smoke from reaching the Smoke Alarm. To avoid dead air spaces, follow the installation recommendations below.

**ON CEILINGS**, install Smoke Alarms as close to the center of the ceiling as possible. If this is not possible, install the Smoke Alarm at least 4 inches (102 mm) from the wall or corner.

**FOR WALL MOUNTING** (if allowed by building codes), the top edge of Smoke Alarms should be placed between 4 and 12 inches (102 and 305 mm) from the wall/ceiling line, below typical "dead air" spaces.

**ON A PEAKED, GABLED, OR CATHEDRAL CEILING**, install the first Smoke Alarm within 3 feet (0.9 meters) of the peak of the ceiling, measured horizontally. Additional Smoke Alarms may be required depending on the length, angle, etc. of the ceiling's slope. Refer to NFPA 72 for details on requirements for sloped or peaked ceilings.

---

## LIMITED WARRANTY

BRK Brands, Inc., ("BRK") the maker of First Alert® brand products warrants that for a period of ten years from the date of purchase, this product will be free from defects in material and workmanship. BRK, at its option, will repair or replace this product or any component of the product found to be defective during the warranty period. Replacement will be made with a new or remanufactured product or component. If the product is no longer available, replacement may be made with a similar product of equal or greater value. This is your exclusive warranty. This warranty is valid for the original retail purchaser from the date of initial retail purchase and is not transferable. Keep the original sales receipt. Proof of purchase is required to obtain warranty performance. BRK dealers, service centers, or retail stores selling BRK products do not have the right to alter, modify or any way change the terms and conditions of this warranty. This warranty does not cover normal wear of parts or damage resulting from any of the following: negligent use or misuse of the product, use on improper voltage or current, use contrary to the operating instructions, disassembly, repair or alteration by anyone other than BRK or an authorized service center. Further, the warranty does not cover Acts of God, such as fire, flood, hurricanes and tornadoes or any batteries that are included with this unit. BRK shall not be liable for any incidental or consequential damages caused by the breach of any express or implied warranty. Except to the extent prohibited by applicable law, any implied warranty of merchantability or fitness for a particular purpose is limited in duration to the duration of the above warranty. Some states, provinces or jurisdictions do not allow the exclusion or limitation of incidental or consequential damages or limitations on how long an implied warranty lasts, so the above limitations or exclusion may not apply to you. This warranty gives you specific legal rights, and you may also have other rights that vary from state to state or province to province.



### **▲WARNING!**

- This unit will not alert hearing impaired residents. It is recommended that you install special units which use devices like flashing strobe lights to alert hearing impaired residents.
- Do not connect this unit to any other alarm or auxiliary device. It is a single-station unit that cannot be linked to other devices. Connecting anything else to this unit may prevent it from working properly.
- Unit will not operate without battery power. The Smoke Alarm cannot work until you install the battery in the correct position (Match "+" to "+" and "-" to "-").
- This Smoke Alarm has a battery door which resists closing unless a battery is installed.

### **▲CAUTION!**

- Do not install this unit over an electrical junction box. Air currents around junction boxes can prevent smoke from reaching the sensing chamber and prevent the unit from alarming. Only AC powered units are intended for installation over junction boxes.
- Do not stand too close to the unit when the alarm is sounding. It is loud to wake you in an emergency. Exposure to the horn at close range may harm your hearing.
- Do not paint over the unit. Paint may clog the openings to the sensing chamber and prevent the unit from operating properly.

## **ABOUT SMOKE ALARMS**

**Battery (DC) operated Smoke Alarms:** Provide protection even when electricity fails, provided the batteries are fresh and correctly installed. Units are easy to install, and do not require professional installation.

**AC powered Smoke Alarms:** Can be interconnected so if one unit senses smoke, all units alarm. They do not operate if electricity fails.  
**AC with battery (DC) back-up:** will operate if electricity fails, provided the batteries are fresh and correctly installed. AC and AC/DC units must be installed by a qualified electrician.

**Smoke Alarms for Solar or Wind Energy users and battery backup power systems:** AC powered Smoke Alarms should only be operated with true or pure sine wave inverters. Operating this Smoke Alarm with most battery-powered UPS (uninterruptible power supply) products or square wave or "quasi sine wave" inverters **will damage the Alarm**. If you are not sure about your inverter or UPS type, please consult with the manufacturer to verify.

**Smoke Alarms for the hearing impaired:** Special purpose Smoke Alarms should be installed for the hearing impaired. They include a visual alarm and an audible alarm horn, and meet the requirements of the Americans With Disabilities Act. Can be interconnected so if one unit senses smoke, all units alarm.

**Smoke alarms are not to be used with detector guards** unless the combination has been evaluated and found suitable for that purpose.

All these Smoke Alarms are designed to provide early warning of fires if located, installed and cared for as described in the user's manual, and if smoke reaches them. If you are unsure which type of Smoke Alarm to install, refer to Chapter 2 of the National Fire Protection Association (NFPA) Standard 72 (National Fire Alarm and Signaling Code) and NFPA 101 (Life Safety Code). National Fire Protection Association, One Batterymarch Park, Quincy, MA 02269-9101. Local building codes may also require specific units in new construction or in different areas of the home.

### **How to Obtain Warranty Service**

**Service:** If service is required, do not return the product to your retailer. In order to obtain warranty service, contact the Consumer Affairs Division at 1-800-323-9005, 7:30 AM - 5:00 PM Central Standard Time, Monday through Friday. To assist us in serving you, please have the model number and date of purchase available when calling.

**For Warranty Service return to:** 1301 Joe Battle El Paso, TX 79936

**Battery:** BRK Brands, Inc. make no warranty, express or implied, written or oral, including that of merchantability or fitness for any particular purpose with respect to battery.

## **SPECIAL COMPLIANCE CONSIDERATIONS**

This Smoke Alarm is suitable for use in apartments, condominiums, townhouses, hospitals, day care facilities, health care facilities, boarding houses, group homes and dormitories provided a primary fire detection system already exists to meet fire detection requirements in common areas like lobbies, hallways, or porches. Using this Smoke Alarm in common areas may not provide sufficient warning to all residents or meet local fire protection ordinances/regulations.

This Smoke Alarm alone is not a suitable substitute for complete fire detection systems in places housing many people—like apartment buildings, condominiums, hotels, motels, dormitories, hospitals, health care facilities, nursing homes, day care facilities, or group homes of any kind. It is not a suitable substitute for complete fire detection systems in warehouses, industrial facilities, commercial buildings, and special-purpose non-residential buildings which require special fire detection and alarm systems. Depending on the building codes in your area, this Smoke Alarm may be used to provide additional protection in these facilities.

In new construction, most building codes require the use of AC or AC/DC powered Smoke Alarms only. In existing construction, AC, AC/DC, or DC powered Smoke Alarms can be used as specified by local building codes. Refer to NFPA 72 (National Fire Alarm and Signaling Code) and NFPA 101 (Life Safety Code), local building codes, or consult your Fire Department for detailed fire protection requirements in buildings not defined as "households".

## **LIMITATIONS OF SMOKE ALARMS**

Smoke Alarms have played a key role in reducing deaths resulting from home fires worldwide. However, like any warning device, Smoke Alarms can only work if they are properly located, installed, and maintained, and if smoke reaches them. They are not foolproof.

**Smoke alarms may not waken all individuals.** Practice the escape plan at least twice a year, making sure that everyone is involved – from kids to grandparents. Allow children to master fire escape planning and practice before holding a fire drill at night when they are sleeping. If children or others do not readily waken to the sound of the smoke alarm, or if there are infants or family members with mobility limitations, make sure that someone is assigned to assist them in fire drill and in the event of an emergency. It is recommended that you hold a fire drill while family members are sleeping in order to determine their response to the sound of the smoke alarm while sleeping and to determine whether they may need assistance in the event of an emergency.

**Smoke Alarms cannot work without power.** Battery operated units cannot work if the batteries are missing, disconnected or dead, if the wrong type of batteries are used, or if the batteries are not installed correctly. AC units cannot work if the AC power is cut off for any reason (open fuse or circuit breaker, failure along a power line or at a power station, electrical fire that burns the electrical wires, etc.). If you are concerned about the limitations of battery or AC power, install both types of units.

**Smoke Alarms cannot detect fires if the smoke does not reach them.** Smoke from fires in chimneys or walls, on roofs, or on the other side of closed doors may not reach the sensing chamber and set off the alarm. That is why one unit should be installed inside each bedroom or sleeping area—especially if bedroom or sleeping area doors are closed at night—and in the hallway between them.

**Smoke Alarms may not detect fire on another floor or area of the home.** For example, a stand-alone unit on the second floor may not detect smoke from a basement fire until the fire spreads. This may not give you enough time to escape safely. That is why recommended minimum protection is at least one unit in every sleeping area, and every bedroom on every level of your home. Even with a unit on every floor, stand-alone units may not provide as much protection as interconnected units, especially if the fire starts in a remote area. Some safety experts recommend installing interconnected AC powered units with battery back-up (see "About Smoke Alarms") or professional fire detection systems, so if one unit senses smoke, all units alarm. Interconnected units may provide earlier warning than stand-alone units since all units alarm when one detects smoke.

**Smoke Alarms may not be heard.** Though the alarm horn in this unit meets or exceeds current standards, it may not be heard if: 1) the unit is located outside a closed or partially closed door, 2) residents recently consumed alcohol or drugs, 3) the alarm is drowned out by noise from stereo, TV, traffic, air conditioner or other appliances, 4) residents are hearing impaired or sound sleepers. Special purpose units, like those with visual and audible alarms, should be installed for hearing impaired residents.

**Smoke Alarms may not have time to alarm before the fire itself causes damage, injury, or death, since smoke from some fires may not reach the unit immediately. Examples of this include persons smoking in bed, children playing with matches, or fires caused by violent explosions resulting from escaping gas.**

**Smoke Alarms are not foolproof.** Like any electronic device, Smoke Alarms are made of components that can wear out or fail at any time. You must test the unit weekly to ensure your continued protection. Smoke Alarms cannot prevent or extinguish fires. They are not a substitute for property or life insurance.

**Smoke Alarms have a limited life.** The unit should be replaced immediately if it is not operating properly. You should always replace a Smoke Alarm after 10 years from date of purchase. Write the purchase date on the space provided on back of unit.