

INSTALLATION INFORMATION FOR QUANTUM BI601/451 SERIES BUILT-IN OVENS

IMPORTANT INFORMATION

Read the instructions before installing or using this product.

Please make this information available to the person responsible for installing this oven as soon as possible, it could reduce your installation cost.

CAUTION

In order to avoid a hazard these products must be installed according to these instructions for installation.

Please follow installation information carefully. If in doubt consult your local building authority by-laws.

Failure to install the appliance correctly could invalidate any warranty or liability claims and lead to prosecution.

The product is to be installed only by an authorised person.

WARNINGS

The cavity must be a completely sealed box with no gaps. This will ensure the cooling air flows under the product to give the correct venting and cooling for the oven and cabinet surround.

Take care of sharp edges when handling products.

BEFORE YOU START

DO Ensure a suitable disconnection switch is incorporated in the permanent wiring, positioned to comply with the Local Wiring Rules and Regulations.

DO Ensure that the location of the oven connection socket is outside the installation space if the appliance is flush to the rear wall.

DO Ensure the benchtop and the oven cavity are square and level.

DO Ensure the electrician allows at least 1.5m free length of connection cable within the cavity for ease of installation and service of the oven.

DO Ensure that the interconnection cord between the cooktop and the oven or control box is not accessible via cupboard doors after installation. This applies to any extension cord as well, even though they are double insulated.

DO Use easy to clean finishes for the wall surfaces surrounding the oven and cooktop to aid removal of any cooking fume staining resulting from the use of the oven and cooktop.

DO Check the height from the floor suits the user.

DO Ensure that drawers and doors will be clear of obstruction when fully opened.

ASTRO/AERON SINGLE BUILT-IN OVEN SERIES SPECIFICATIONS

SINGLE OVEN SPECIFICATIONS

AERON SINGLE (BI601QAE/QAA) OVEN &
ASTRO SINGLE (BI601QASX/QASE) OVEN

	Oven	Cabinet
Overall Width	595 mm	568 mm
Overall Height	595 mm	585 mm
Depth	562 mm	550 mm

Note Oven front dimensions differ from cabinet dimensions.

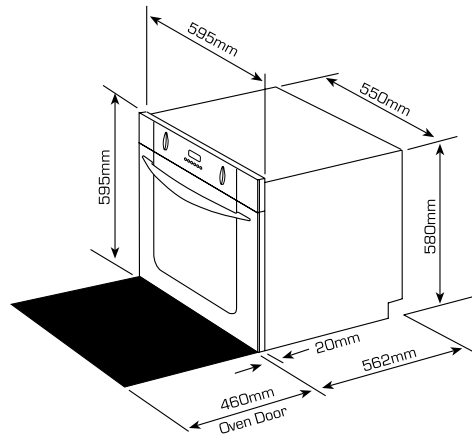

AERON SINGLE
(BI601QAE/QAA)
&
ASTRO SINGLE
(BI601QASX/QASE)

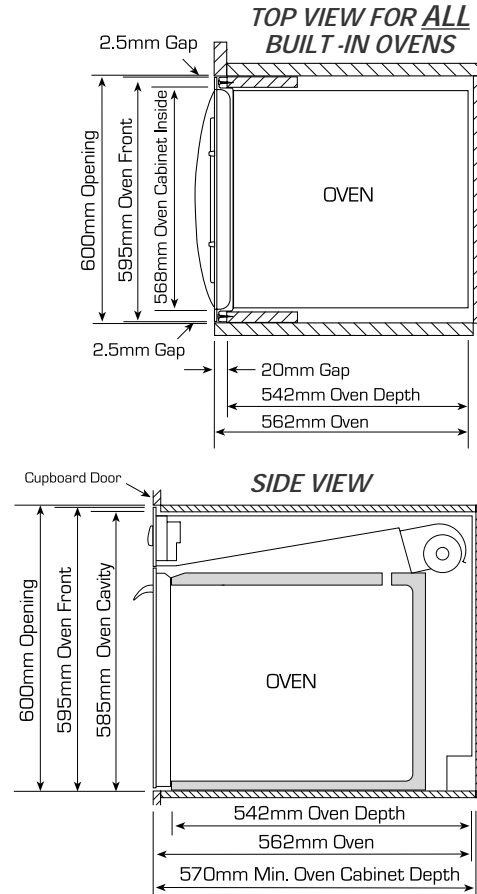

COMPACT OVEN SPECIFICATIONS

ASTRO COMPACT (BI451QASP) OVEN

	Oven	Cabinet
Overall Width	595 mm	568 mm
Overall Height	450 mm	440 mm
Depth	562 mm	550 mm

Note Oven front dimensions differ from cabinet dimensions.

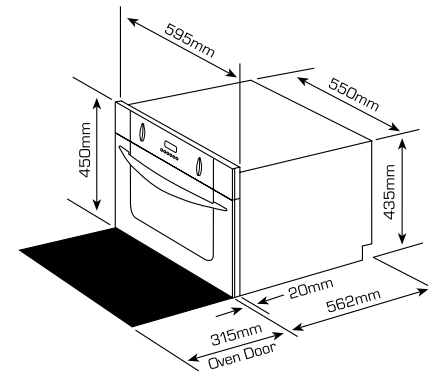

Note Astro Compact Oven 'Top View' is the same as for Single Ovens.

ASTRO COMPACT
(BI451QASP)

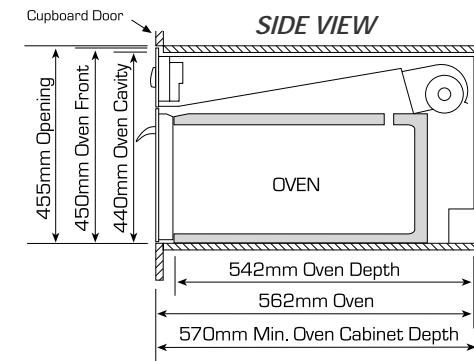

ASTRO DOUBLE BUILT-IN OVEN SERIES SPECIFICATIONS

DOUBLE OVEN SPECIFICATIONS

ASTRO E1.5 (BI601QASE1.5)
DOUBLE OVEN

	Oven	Cabinet
Overall Width	595 mm	568 mm
Overall Height	932 mm	922 mm
Depth	562 mm	550 mm

Note Oven front dimensions differ from cabinet dimensions.

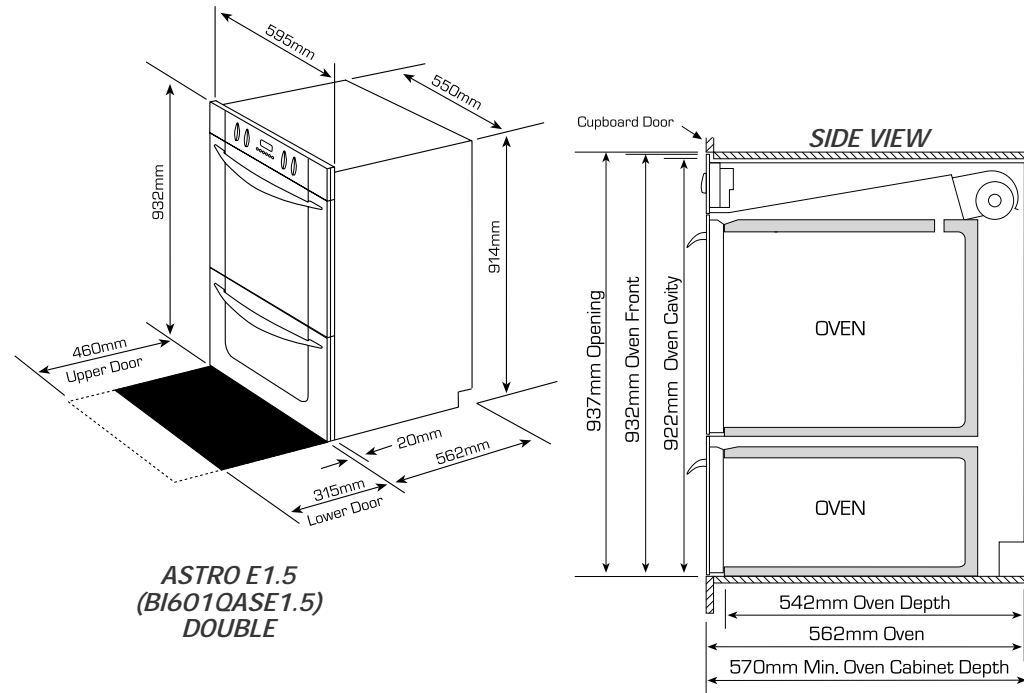

TOWER OVEN SPECIFICATIONS

ASTRO E2 (BI601QASE2)
TOWER OVEN

	Oven	Cabinet
Overall Width	595 mm	568 mm
Overall Height	1078 mm	1068 mm
Depth	562 mm	550 mm

Note Oven front dimensions differ from cabinet dimensions.

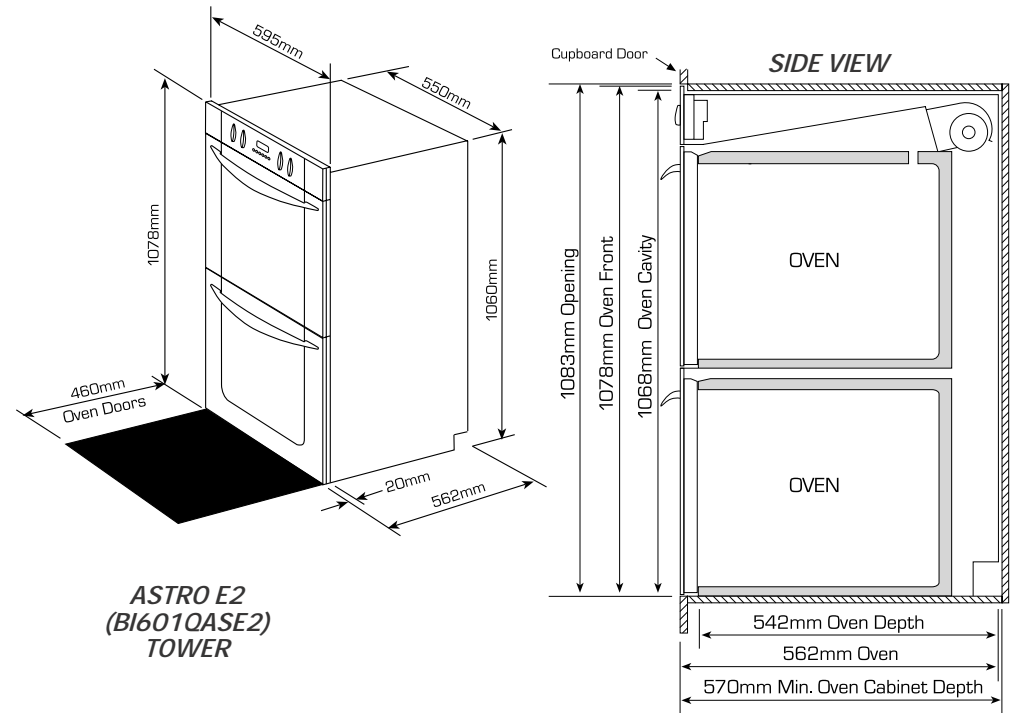

BUILT-IN OVEN INSTALLATION INSTRUCTIONS

FLUSH FITTING INSTALLATION OPTIONS

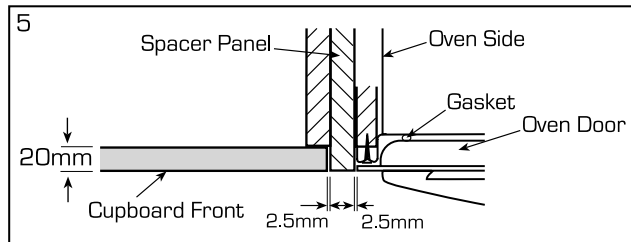
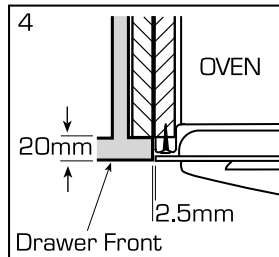
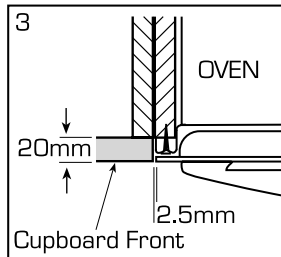
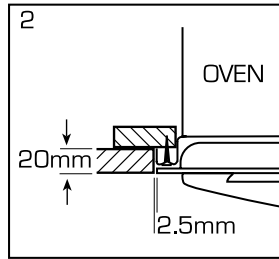
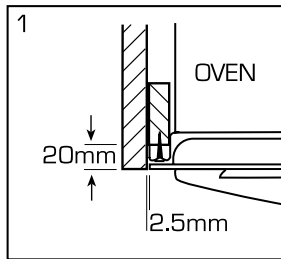

INSTALLATION INSTRUCTIONS

1. Check that the kitchen cavity is square and within the limits in the installation dimensions.
2. Lift oven and slide into place. Locate oven in the centre of the cavity, ensuring that the front is flush with surrounding cabinetry.
3. Secure oven in cavity, using the four 'wood screws' and washers supplied, through the enamelled frame at either side of the oven.
4. Check that the oven is firmly secured in the kitchen unit.

COOKTOP ABOVE SINGLE OR COMPACT OVEN

If installing a cooktop above the oven, ensure adequate clearance is provided for the cooktop as per the Cooktop Manufacturers Instructions.

CUSTOMER SUPPORT

Before you call for service or assistance...

Check the things you can do yourself.
Refer to your User Guide and check...

1. Your product is correctly installed.
2. You are familiar with its normal operation.

If after checking these points you still need assistance, please call your Fisher & Paykel retailer who is trained to provide information on your product, or if we can be of any further help, please contact our Customer Care Centre.

FOR NEW ZEALAND

P. O. Box 58550, Greenmount, Auckland.
Toll Free 0800 FP CARE Fax 09 273 0656
(0800 37 2273) Email Customer.Care@fp.co.nz

FOR AUSTRALIA

P. O. Box 798, Cleveland, QLD 4163.
Toll Free 1300 650 590 Fax 07 3826 9298
Tel 07 3826 9100 Email Customer.Care@fp.com.au

FOR UNITED KINGDOM (GB)

Fisher & Paykel Appliances Ltd.
Broxell Close, Wedgnock Industrial Estate, Warwick,
Warwickshire, CV34 6QF.
Tel 01 926 626700 Fax 01 926 626701

FOR IRELAND (IE)

C&F Quadrant, Quadrant House, Chapelizod, Dublin 20.
Tel 01 626 5711/4917 Fax 01 626 7863/3251

CURRENT INFORMATION

Current Installation Instructions, Product dimensions and specifications are available on the Fisher & Paykel web site.

www.fisherpaykel.com