







Joiner Kit

For Fisher & Paykel Models: C270, E249T, E240B, E210, E381T, E372B, N388, E388, C450, E450, E402B, E411T, E415H, E413T, E406B, E440T, E442B, E521T & E522B

Fisher & Paykel
appliances

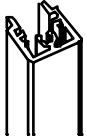
customer care™

KIT COMPONENTS

Part Illustration	Description
	Rear Bracket
	Front Lower Bracket
	Front Upper Bracket
	Extrusion Support
	Extrusion Cover
	Screw Type A: #8x16 PAN PHIL (7)
	Screw Type B: #5x20 HEX PHIL (6)

KIT APPLICATION

This kit is designed for use on 1595mm / 62" & 1695mm / 66" high cabinet models, incorporating the "B, C, D & G" series refrigerator or freezer having curved or flat door styling.

Note: This kit can be used for combining any of the following products of the same height:

1695mm / 66" Tall Cabinets:

N388, E388, C450, E450, E402B, E411T, E415H, E440T, E442B, E521T, E522B

1595mm / 62" Tall Cabinets:

C270, E249T, E240B, E210, E381, E372B, E413T, E406B

TOOLS REQUIRED

1. Philips type screwdriver
2. Flat blade screwdriver
3. 19mm Socket

JOINER KIT PART NUMBERS

Silver – F&P Part Number 819264

White – F&P Part Number 819263

Joiner Kit

For Fisher & Paykel Models: C270, E249T, E240B, E210, E381T, E372B, N388, E388, C450, E450, E402B, E411T, E415H, E413T, E406B, E440T, E442B, E521T & E522B



Models	C270 / E249T / E240B / E210			E381T / E372B / E402B / E411T/ E415H / C450 / E450 / N388 / E388			E413T / E406B / E440T / E442B		E521T / E522B
Product Dimensions (mm)									
A Width	525			635			680		790
Combined Models (mm/inches)	525+525 Model	525+635 Model	525+680 Model	635+635 Model	635+680 Model	635+790 Model	680+680 Model	680+790 Model	790+790 Model
B Height	1595 / 62 ¾	1595 / 62 ¾	1595 / 62 ¾	1695 / 66 ¾	1695 / 66 ¾	1695 / 66 ¾	1695 / 66 ¾	1695 / 66 ¾	1695 / 66 ¾
C Width	1075 / 42 3/8	1185 / 46 5/8	1230 / 48 ½	1295 / 51	1340 / 52 ¾	1450 / 57	1385 / 54 ½	1495 / 58 7/8	1605 / 63 1/8
D Depth of curved door not including handle	572 / 22 ½	696 / 27 3/8	696 / 27 3/8	696 / 27 3/8	696 / 27 3/8	696 / 27 3/8	696 / 27 3/8	696 / 27 3/8	696 / 27 3/8
E Depth of flat door not including handle	N/A	685 / 27	685 / 27	685 / 27	685 / 27	685 / 27	685 / 27	685 / 27	685 / 27
Cabinetry Dimensions - including minimum clearances									
F Inside height	1645 / 64 ¾	1645 / 64 ¾	1645 / 64 ¾	1745 / 68 ¾	1745 / 68 ¾	1745 / 68 ¾	1745 / 68 ¾	1745 / 68 ¾	1745 / 68 ¾
1. Flush with refrigerator chassis – full door rotation									
G Inside width	1115 / 44	1205 / 47 ½	1270 / 50	1335 / 51 ½	1380 / 54 3/8	1490 / 58 5/8	1425 / 56 1/8	1535 / 60 ½	1645 / 64 ¾
H Inside depth flush to chassis	502 / 19 ¾	620 / 24 3/8	620 / 24 3/8	620 / 24 3/8	620 / 24 3/8	620 / 24 3/8	620 / 24 3/8	620 / 24 3/8	620 / 24 3/8
2. Flush with refrigerator door – 90° door rotation									
I Inside width	1125 / 44 3/8	1235/48 5/8	1280/ 50 ½	1345 / 53	1390/54 ¾	1500/59	1435/56 ½	1545/60 7/8	1655/65 1/8
J Inside depth flush to curved door	575 / 22 5/8	724 / 28 ½	724 / 28 ½	724 / 28 ½	724 / 28 ½	724 / 28 ½	724 / 28 ½	724 / 28 ½	724 / 28 ½
K Inside depth flush to flat door	N/A	696 / 27 3/8	696 / 27 3/8	696 / 27 3/8	696 / 27 3/8	696 / 27 3/8	696 / 27 3/8	696 / 27 3/8	696 / 27 3/8
3. Flush with refrigerator door – full door rotation									
L Inside width	1355 / 53 3/8	1465 / 57 ¾	1510 / 59 ½	1575 / 62	1620 / 63 ¾	1730 / 68 1/8	1665 / 65 ½	1775 / 69 7/8	1885 / 74 ¼
M Inside depth flush to curved door	575 / 22 5/8	724 / 28 ½	724 / 28 ½	724 / 28 ½	724 / 28 ½	724 / 28 ½	724 / 28 ½	724 / 28 ½	724 / 28 ½
N Inside depth flush to flat door	N/A	696 / 27 3/8	696 / 27 3/8	696 / 27 3/8	696 / 27 3/8	696 / 27 3/8	696 / 27 3/8	696 / 27 3/8	696 / 27 3/8
Minimum clearances									
O Side clearance flush with refrigerator chassis	20 / ¾	20 / ¾	20 / ¾	20 / ¾	20 / ¾	20 / ¾	20 / ¾	20 / ¾	20 / ¾
P Side clearance flush with door 90 rotation	25 / 1	25 / 1	25 / 1	25 / 1	25 / 1	25 / 1	25 / 1	25 / 1	25 / 1
Q Side clearance flush with door full rotation		140 / 5 ½	140 / 5 ½	140 / 5 ½	140 / 5 ½	140 / 5 ½	140 / 5 ½	140 / 5 ½	140 / 5 ½
R Rear including evaporator tray	30 / 1 1/8	30 / 1 1/8	30 / 1 1/8	30 / 1 1/8	30 / 1 1/8	30 / 1 1/8	30 / 1 1/8	30 / 1 1/8	30 / 1 1/8
S Vent	50 / 2	50 / 2	50 / 2	50 / 2	50 / 2	50 / 2	50 / 2	50 / 2	50 / 2

Joiner Kit

For Fisher & Paykel Models: C270, E249T, E240B, E210, E381T, E372B, N388, E388, C450, E450, E402B, E411T, E415H, E413T, E406B, E440T, E442B, E521T & E522B

CAVITY / VENTILATION REQUIREMENTS

1. Flush with refrigerator chassis – full door rotation.

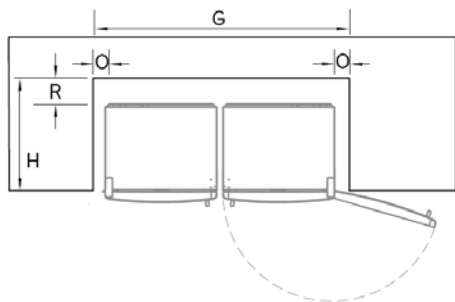

2. Flush with refrigerator door – 90° door rotation.

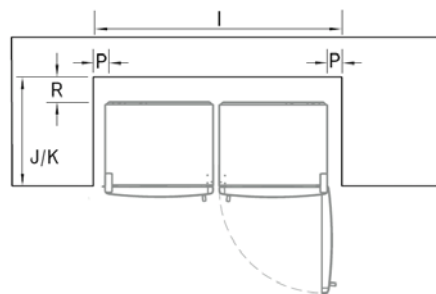

3. Flush with refrigerator door – full door rotation.

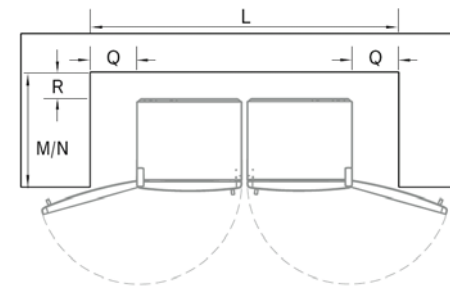

Note: For full draw/shelf access the doors need to open past 90°

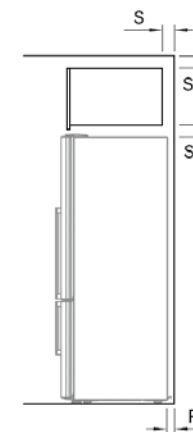
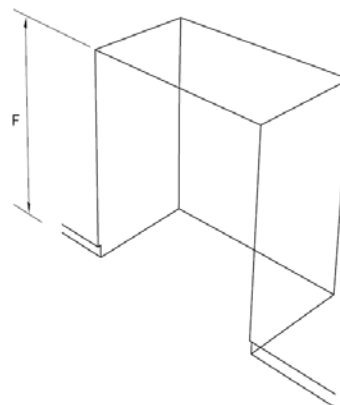
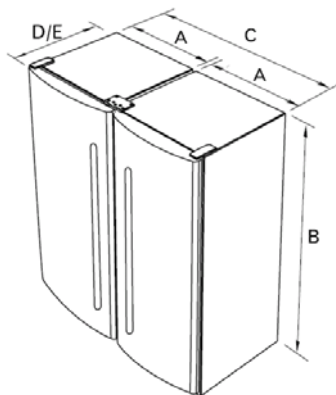

Surround Kits are available, please contact Fisher & Paykel Customer Care 0800 FP CARE or 0800 37 2273 for further information on kit sizes and finishes.

Joiner Kit

For Fisher & Paykel Models: C270, E249T, E240B, E210, E381T, E372B, N388, E388, C450, E450, E402B, E411T, E415H, E413T, E406B, E440T, E442B, E521T & E522B

Fisher & Paykel
appliances

customer care™

PREPARE FOR INSTALLATION

Step 1.

1. Check that the internal cupboard cavity dimensions are correct for the type of installation you require.
2. Unpack the refrigerator and freezer cabinets from their separate delivery cartons (see individual cartons for unpacking procedures).
3. Ensure the floor and/or the cupboards are protected from damage during the unpacking and assembly of the cabinets.
4. Check the refrigerator and freezer doors are hinged on the desired side.
5. Check that the Kit is complete (refer to Joiner Kit parts list on page 1).

Note: due to the size of the refrigerator cabinets, it is essential that any assembly of the kit be undertaken with a minimum of two able-bodied persons.

INSTALLATION PROCEDURE

Step 2.

If your refrigerator has a unit compartment cover at the back, remove using a Phillips type screw driver (USA market only). This will be re-attached later.

Looking at the back of the two products, locate the Rear Bracket onto the rear bottom left hand edge of the right hand side product. Care must be taken to line up the top edge of the Rear Bracket with the bottom edge of the white back panel. Secure the Rear Bracket with 3 of the screws (Type A, self tapping, silver). These 3 screws are mounted from the side. Please note there are no pre-drilled holes for these screws which hold the rear bracket onto the side of the cabinet.

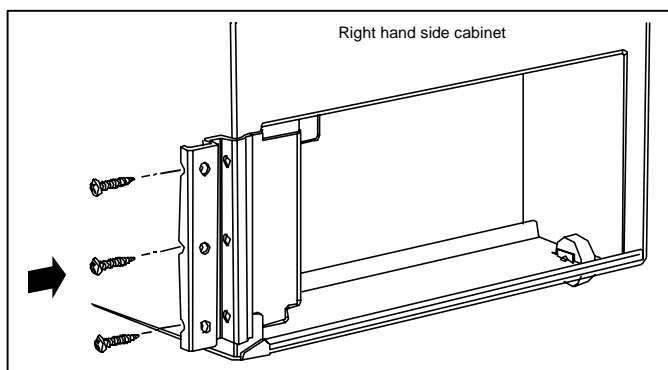

Step 2

Step 3.

Locate the left hand side cabinet's bottom right rear wall within the open "U" section in the rear bracket. Ensure that the cabinet sits firmly with the rear bracket.

Do not secure with screws (see page 4).

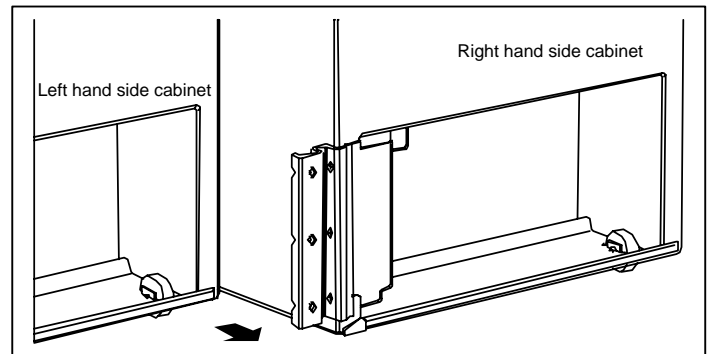

Step 3

Step 4.

Locate the front adjustable feet. One can be found at each of the cabinet's front lower corners.

Adjust the two feet by turning either clockwise or anti-clockwise until the two cabinets are level.

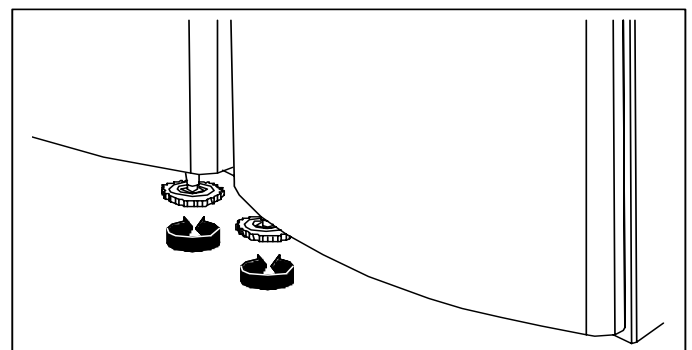

Step 4

Step 5.

Remove the three screw hole caps from the top surface of each of the cabinets with a small flat bladed screwdriver by gently prising them loose. The caps can be found on the front edge of the top surface of the cabinets, opposite side to the hinge. Ensure that the top panel is not scratched or deformed during this process. The total of six screw hole caps are not required to be used with the kit.

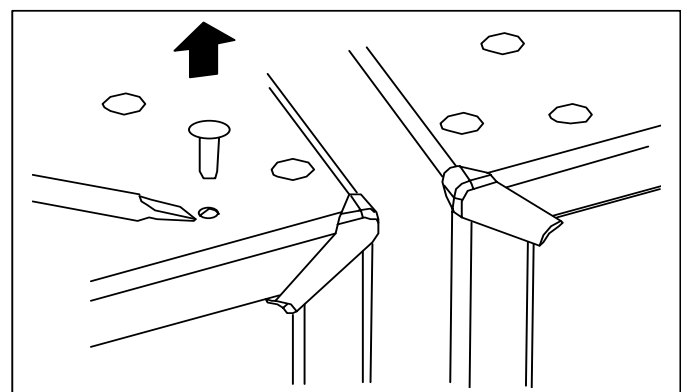

Step 5

Joiner Kit

For Fisher & Paykel Models: C270, E249T, E240B, E210, E381T, E372B, N388, E388, C450, E450, E402B, E411T, E415H, E413T, E406B, E440T, E442B, E521T & E522B

Fisher & Paykel
appliances

customer care™

Step 6.

Locate the front upper bracket on the top surface of the two cabinets, taking care to line up the bosses on the Front Upper Bracket, with the six screw points.

Note that the large centered rectangular section on the underside of the front upper bracket acts as a spacer between the two cabinets. Partially engage all of the screws (Type B, hex head, silver) prior to their final tightening.

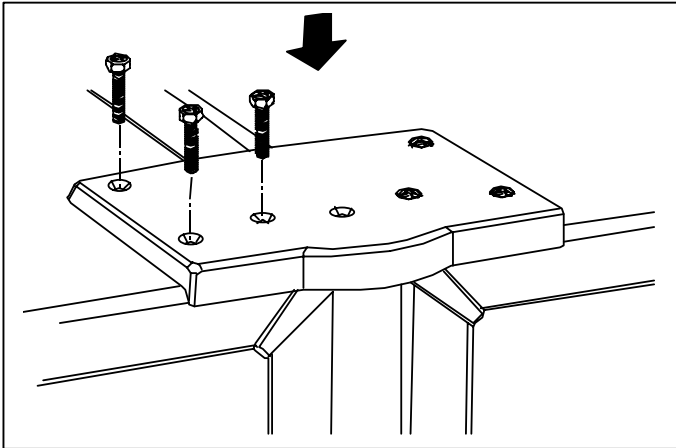

Step 6

Step 7.

Ensure the left cabinet is properly located within the rear bracket and that the cabinets are level. Secure the left cabinet to the rear bracket using 3 of the screws (Type A, self tapping, silver).

Now replace the unit compartment cover at the back using a Phillips type screw driver (USA market only)

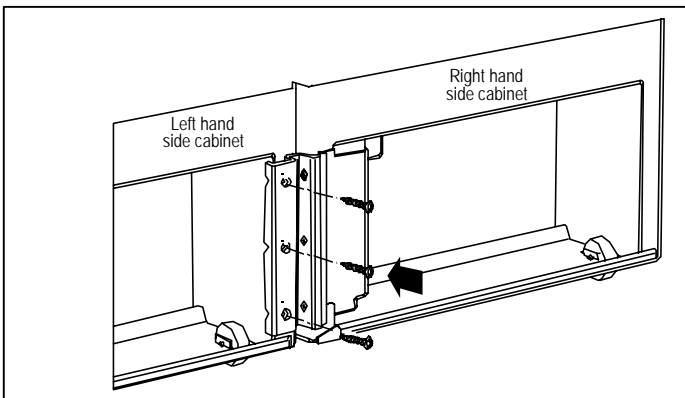

Step 7

Step 8

To access the adjustable feet and to locate the front lower bracket, the joined cabinets must be tilted backwards approximately 60 degrees. This is a two person operation.

The person at the rear of the cabinets must acknowledge that they have a secure grip of the cabinets prior to any work being undertaken by the second installer.

Care must be taken not to damage either the cabinets/floor or the surrounding cupboards during this operation.

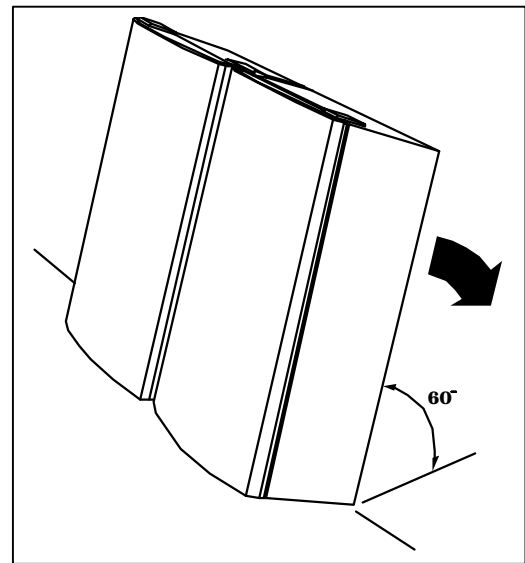

Step 8

Step 9

Remove the two Levelling Feet by rotating them anti-clockwise then remove the two bolts.

Note: C450, E450, E440T, E442B, E521T and E522B may have an extra component as part of the levelling foot assembly, this being a stepped plastic washer. If this part is located, it is to be removed as it is not required to be used with this kit.

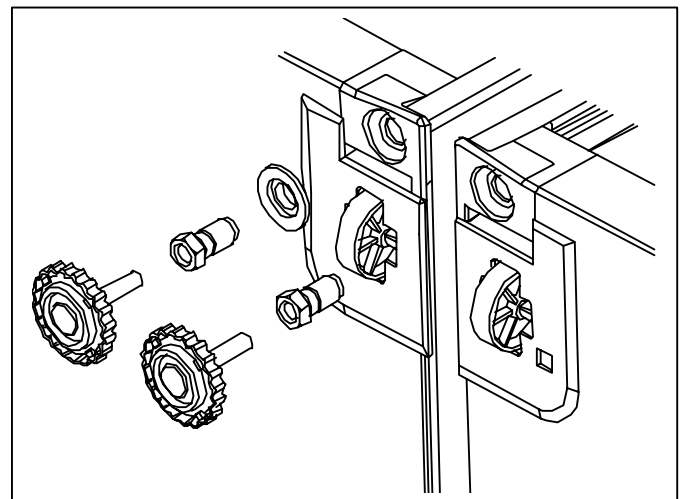

Step 9

Joiner Kit

For Fisher & Paykel Models: C270, E249T, E240B, E210, E381T, E372B, N388, E388, C450, E450, E402B, E411T, E415H, E413T, E406B, E440T, E442B, E521T & E522B

Fisher & Paykel
appliances

customer care™

The Front Lower Bracket is now located on the underside of the Cabinets. Care must be taken to orient the bracket so that the two small tabs are located with the slots on the underside of the Cabinet.

Step 10

The two Leveling Feet Mounting Bolts are firmly located back onto the cabinet, securing the Front Lower Bracket.

The two Leveling Feet are now screwed back into their existing position. Once assembled, lower the Refrigerator assembly back to a standing position, taking care not to damage it or the surrounding cupboards/floor.

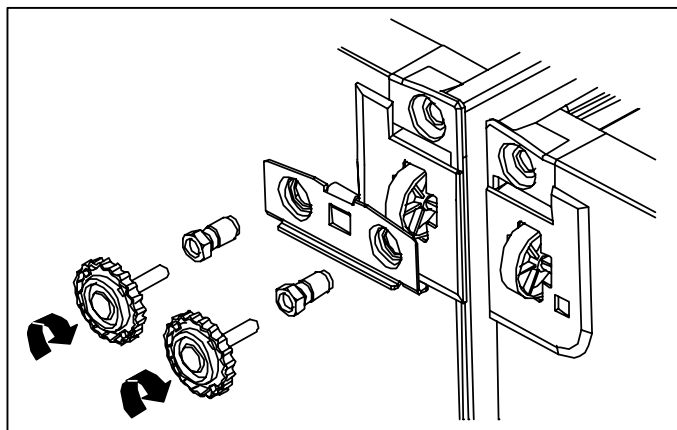

Step 10

Step 11

Before loading the Trim Panel Assembly, The six Type B Screws must be loosened from the Front Top Bracket, so that the bracket can be freely moved up and down (approximately 5mm/1/8").

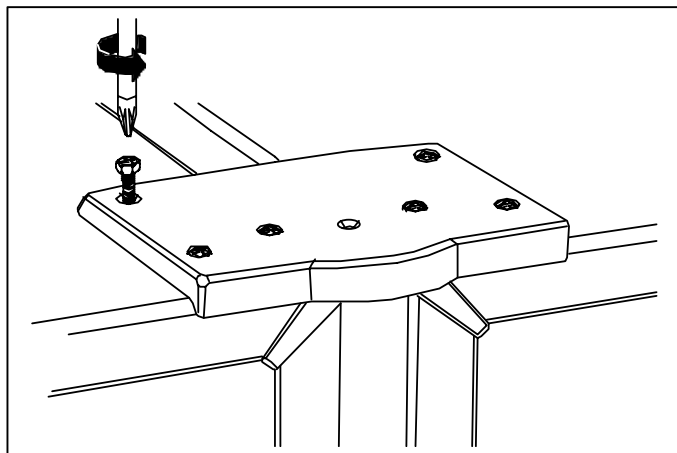

Step 11

Step 12

Open both the cabinet doors for easy access to the center join of the two Cabinets.

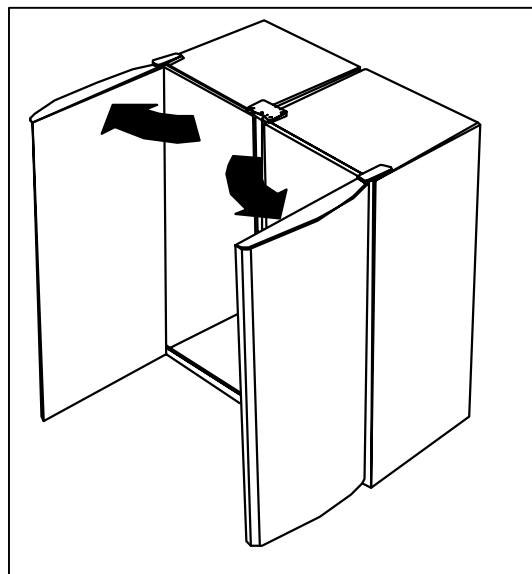

Step 12

Step 13

If using kit on shorter models, cut Trim Panel Assembly (Extrusion cover & Extrusion support) to length shown in table below.

Model	Trim Height (mm / inches)
C270, E249T, E240B, E210, E381T, E372B, E413T, E406B	1562 / 61 1/2
N388, E388, C450, E450, E402B, E411T, E415H, E440T, E442B, E521T, E522B	1662 / 65 1/2 (Standard Height)

Locate the Trim Panel Assembly on the upright tab that protrudes from the Front Lower Bracket.

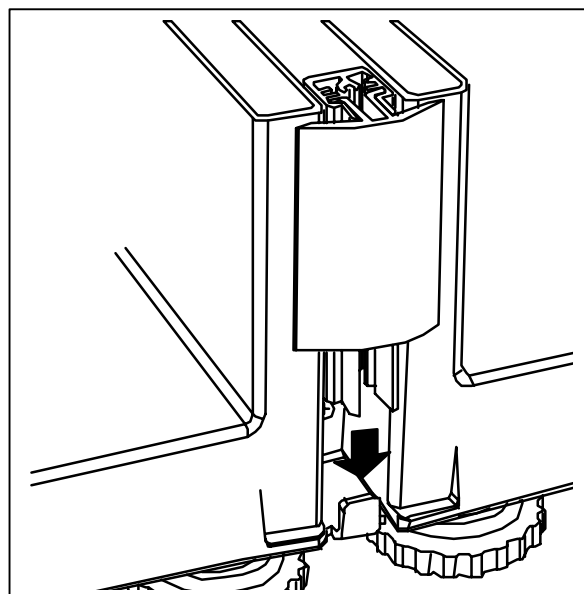

Step 13

Joiner Kit

For Fisher & Paykel Models: C270, E249T, E240B, E210, E381T, E372B, N388, E388, C450, E450, E402B, E411T, E415H, E413T, E406B, E440T, E442B, E521T & E522B

Fisher & Paykel
appliances

customer care™

Step 14

Locate the Trim Panel Assembly under the Front Upper Bracket. The Front Upper Bracket should be free to move up and down to aid installation (see diagram 13).

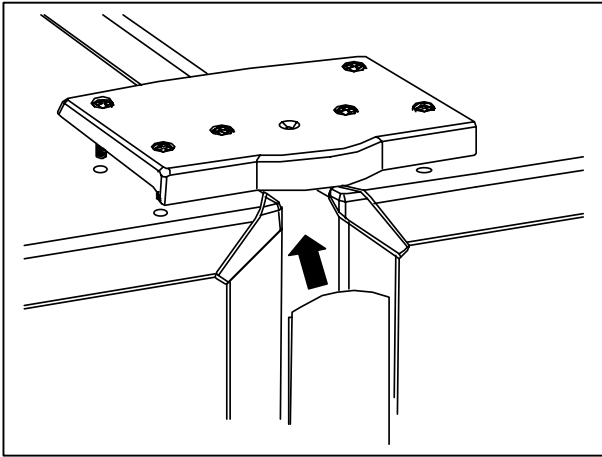

Step 14

Step 15

Tighten the 6 Type B Screws to locate the Front Upper Bracket. Secure the Trim Panel Assembly with one screw (Type A, Self Tapping, Silver).

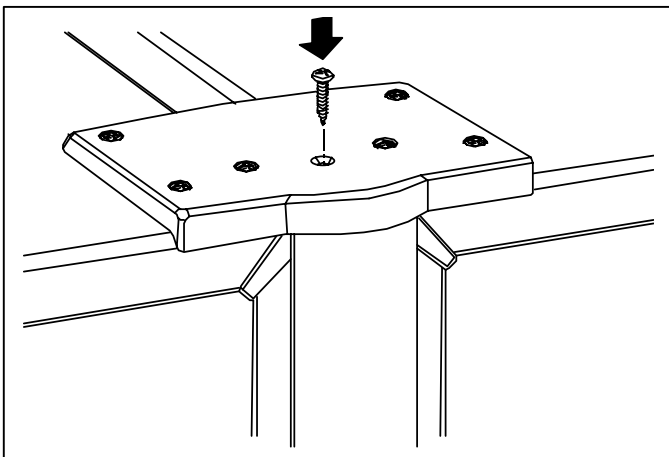

Step 15

COMPLETE THE INSTALLATION PROCEDURE

Step 16

Close the Refrigerator doors, ensuring that all door seals sit flush against the front walls of the Cabinets.

Step 17

Complete the installation by locating the assembled combined cabinets within the Cupboard Cavity (refer to page 2 for Cupboard Cavity dimensions).

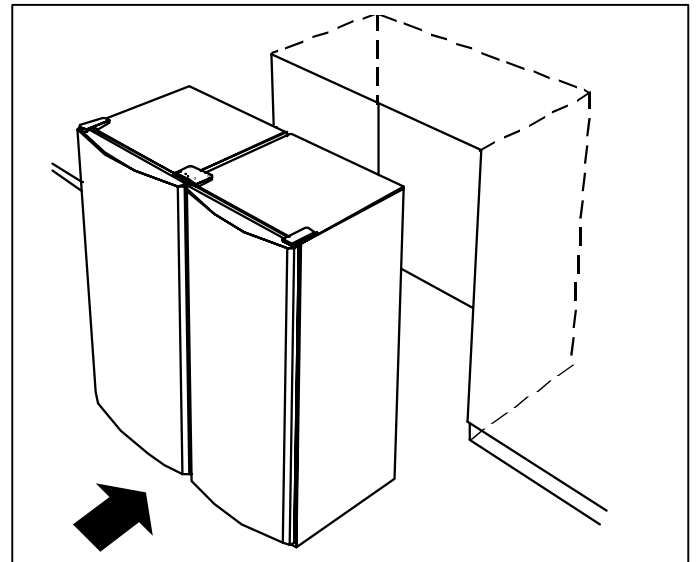

Step 17

Step 18

If doors are out of line after installation is complete, undo top door hinge bracket of the un-aligned door by unscrewing all 3 screws halfway. Align by moving the door left or right. Once aligned, re-screw the hinge bracket.

Ensure the front leveling feet are adjusted to take the load of the combined cabinets. Note: Adjusting the leveling feet can also affect the door alignment.



Step 18