

Rebound

Game • Juego • Jeu



WARNING:
CHOKING HAZARD -
Toy contains marbles.
Not for children under 3 years.

ADVERTENCIA:
PUEDE CAUSAR ASFIXIA.
No recomendable para menores de 3 años.
Contiene bolas pequeñas.

ATTENTION:
NE CONVIENT PAS aux enfants
de moins de 36 mois. - Le jouet peut contenir
de petites balles.

©2003 Mattel Inc., El Segundo, CA 90245 U.S.A. All Rights Reserved. Tous droits réservés.

Mattel Canada Inc., Mississauga, Ontario L5R 3W2. You may call us free at 1-800-665-6288.
Mattel U.K. Ltd., Vanwall Business Park, Maidenhead SL6 4UB. Helpline: 01628500303.
Mattel France, 27/33 rue d'Antony, Sillic 145, 94523 Rungis Cedex N° Indigo 0 825 00 00 25 ou
www.allomattel.com.

Mattel B.V., Postbus 576, 1180 AN Amstelveen, Nederland. 0800 - 2628835.
Mattel Belgium, Trade Mart, Atomiumsquare, Bogota 202 - B 275, 1020 Brussels.
Schweiz: Mattel AG, Monbijoustrasse 68, CH-3000 Bern 23.
Mattel España, S.A., Anbau 200, 08036 Barcelona. N.I.F. A09-842809.
Mattel Portugal Lda., Av. da República, nº 9096, 2º andar Fração 2, 1600-206 Lisboa.
Mattel Australia Pty., Ltd., Richmond, Victoria. 3121. Consumer Advisory Service - 1300 135 312.

Mattel East Asia Ltd., Room 1106, South Tower, World Finance Centre, Harbour City, Tsimshatsui, HK, China.
Diiimport & Diedaikan Oleh: Mattel SEA Ptd Ltd (993532-P) Lot 13.5, 13th Floor, Menara Lien Hoe, Persiaran Tropicana Golf Country Resort, 47410 P.J. Tel:03-78803817, Fax:03-78803867.
Mattel, Inc., El Segundo, CA 90245 U.S.A. Consumer Affairs 1 (800) 524-Toys.
Importado y distribuido por Mattel de México, S.A. de C.V., Insurgentes Sur # 3579, Torre 3, Oficina 601, Col. Tlalpan, Delegación Tlalpan, C.P. 14020, México, D.F. TEL: 54-49-41-00. R.F.C. MME-920701-NB3.
Mattel Chile, S.A., Avenida Américo Vespucio 501-B, Quilicura, Santiago. Mattel de Venezuela, C.A., Ave. Mara, C.C. Macaracuy Plaza, Torre B, Piso 8, Colinas de la California, Caracas 1071.
Mattel Argentina S.A., Curupayti 1186, (1607) - Villa Adelina, Buenos Aires.
Mattel Colombia, S.A., calle 123#7-07 P5, Bogotá.

CLASSIC



CONTENTS

2-Piece Plastic REBOUND Playing Field, 8 Pucks (4 of Each Color), 2 Bumpers.

Please remove all components from package and compare them to the components list. If any items are missing, please call 1-800-524-TOYS. Outside the U.S., please consult your telephone directory for a listing of your local Mattel offices.

OBJECT

Fling your Pucks up the alley to score points. The first Player to reach 500 points wins!

PLAYING FIELD

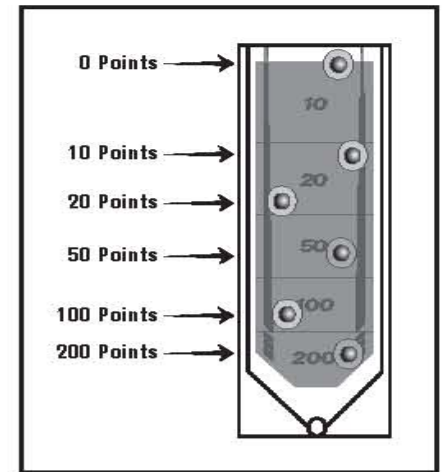
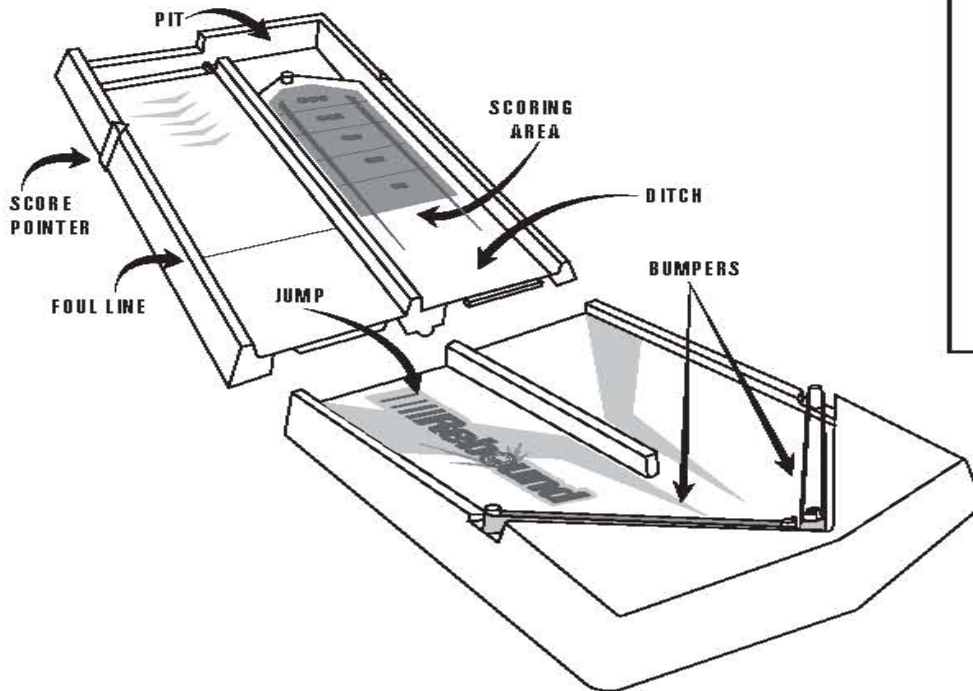

SETUP

1. Lay the 2 halves of the Playing Field on flat, level surface and snap together.
2. Slide each Score Pointer to the "zero" position.
3. Attach 2 Bumpers to the posts at the end of the Playing Field as shown.
4. Each Player selects four matching-color Pucks, and will use the matching Score Pointer to keep track of their score.
5. Each Player takes a turn and the highest score goes first.

TO PLAY

1. On your turn, start below the foul line and slide only one Puck up the alley of the Playing Field toward the Bumpers. The Puck will hit the Bumpers and bounce back down the alley toward the Scoring Area.
2. You **MUST** release the Puck from your hand before reaching the Foul Line. If a Player's hand crosses the foul line, that turn must be taken over.
3. Any Puck that goes off the Playing Field or lands in the Pit is out of play until the round ends.
4. After you have played 1 Puck, it is the next Player's turn. Do not touch or remove your Pucks from the Playing Field until the round is completely over. The round is over when each Player has played all 4 of their Pucks.

STRATEGY HINTS

1. Players may try to knock their opponent's Pucks into the Pit to keep them from being scored. Pucks that land in the Pit stay there until the round ends.
2. You may also want to use the "Ditch" as a defensive block. By using just the right touch, you can make a Puck come off the Jump and land in the Ditch, which could block an opponent's next shot.

SCORING

1. After all the Pucks have been played, the round is scored by adding up the points for each of the Pucks in the Scoring Area.
2. Pucks in the Scoring Area must lie within a particular Point section. If a Puck is touching the line between 2 Point sections, its value is that of the LOWER score.
3. No points are scored for Pucks in the Pit or the Ditch.
4. Register your score for the round with your Score Pointer. Each notch on the side wall stands for 10 points.
Example: If you scored 10 points with one Puck, 50 points with another, 20 with the third, and had one in the Pit, you would slide your Score Pointer 8 notches to represent the total of 80 points scored for that round.
5. After your score has been registered, remove all of your Pucks and begin the next round. The player with the highest score goes first.

WINNING THE GAME

The first player to score 500 points wins the game!

TEAM PLAY

REBOUND may be played in teams of 2 or more players. As Teams alternate turns, Players on each Team must also alternate turns. All other rules and procedures for individual play remain the same. The first team to reach 500 points wins the game!

STORAGE

To disassemble the game for storage: Lift the back end as shown and slide apart.