

# FLAIRCOMM

Flaircomm Microelectronics, Inc.

## FLC-BTM403/FLC-BTMDC748 Datasheet

[www.flairmicro.com](http://www.flairmicro.com)

Document Type: Bluetooth Module Datasheet  
Document Number: FLC-BTM403-DS  
Document Version: V1.3  
Release Date: 2012/11/12

**Copyright 2012 ~ 2014 by Flaircomm Microelectronics Inc., All Right Reserved**

Without written permission from Flaircomm Microelectronics Inc., reproduction, transfer, distribution or storage of part or all of the contents in this document in any form is prohibited



FLAIRCOMM





---

---

### Release Record

Version	Release Date	Comments
1.0	2012/6/26	Release
1.1	2012/9/14	Modify operating temperature. Add BT/CE/FCC logo. Add Cautions & Warnings.
1.2	2012/11/1	Add Antenna Statement.
1.3	2012/11/12	Modify 11.3 Label Instructions.



CONTENTS

**1. INTRODUCTION.....6**

1.1 NAMING DECLARATION .....6

1.2 BLOCK DIAGRAM.....7

1.3 FEATURES .....7

1.4 APPLICATIONS .....7

**2. GENERAL SPECIFICATION .....9**

**3. PIN DEFINITION.....10**

3.1 PIN CONFIGURATION.....10

3.2 PIN DEFINITION.....10

**4. PHYSICAL INTERFACES .....12**

4.1 POWER SUPPLY .....12

4.2 RESET .....12

4.3 DIGITAL AUDIO INTERFACES .....13

4.3.1 PCM Interface Master/Slave .....13

4.3.2 Long Frame Sync .....14

4.3.3 Short Frame Sync .....15

4.3.4 Multi-slot Operation.....15

4.3.5 GCI Interface.....16

4.3.6 Slots and Sample Formats .....16

4.3.7 Additional Features .....17

4.3.8 PCM Timing Information.....17

4.4 RF INTERFACE .....21

4.5 GENERAL PURPOSE ANALOGUE IO .....21

4.6 GENERAL PURPOSE DIGITAL IO.....21

4.7 SERIAL INTERFACES.....21

4.7.1 UART.....21

4.7.2 USB .....22

4.7.3 I<sup>2</sup>C .....24

4.7.4 SPI.....24

**5. ELECTRICAL CHARACTERISTIC .....26**

5.1 ABSOLUTE MAXIMUM RATING .....26

5.2 RECOMMEND OPERATION CONDITIONS .....26

5.3 POWER CONSUMPTIONS.....26

5.4 INPUT/OUTPUT TERMINAL CHARACTERISTICS .....27

5.4.1 Digital Terminals.....27

5.4.2 USB .....27

**6. REFERENCE DESIGN .....28**

**7. MECHANICAL CHARACTERISTIC .....29**

**8. RECOMMENDED PCB LAYOUT AND MOUNTING PATTERN.....30**

**9. RECOMMENDED REFLOW PROFILE .....31**

**10. ORDERING INFORMATION .....32**

10.1 PRODUCT PACKAGING INFORMATION .....32

10.2 ORDERING INFORMATION.....33

10.2.1 Product Revision .....33

10.2.2 Shipping Package .....33

10.2.3 Product Package .....33



10.2.4 Product Grade..... 33

**11. CAUTIONS & WARNINGS ..... 35**

11.1 FCC STATEMENT ..... 35

11.2 FCC RADIATION EXPOSURE STATEMENT ..... 35

11.3 FLC-BTM403 LABEL INSTRUCTIONS ..... 35

11.4 FLC-BTM403 ANTENNA STATEMENT..... 36

    11.4.1 BTM403A and BTM403C ..... 36

    11.4.2 BTM403B ..... 38

### TABLES AND FIGURES

Table 1: Naming Declaration ..... 6

Table 2: General Specification ..... 9

Table 3: Pin Definition ..... 11

Table 4: Pin Status on Reset..... 12

Table 5: PCM Master Timing ..... 18

Table 6: PCM Slave Timing..... 20

Table 7: Possible UART Settings..... 22

Table 8: USB Interface Component Values ..... 23

Table 9: Absolute Maximum Rating Recommended Operating Conditions ..... 26

Table 10: Recommended Operating Conditions ..... 26

Table 11: Power consumptions ..... 26

Table 12: Digital Terminal..... 27

Table 13: USB Terminal ..... 27

Table 14: Product Revision ..... 33

Table 15: Shipping Package ..... 33

Table 16: Product Package ..... 33

Table 17: Product Grade ..... 34

Table 18: Antenna Specifications..... 36

Figure 1: Block Diagram ..... 7

Figure 2: Pin Configuration..... 10

Figure 3: Configured PCM as a Master..... 14

Figure 4: Configured PCM as a Slave..... 14

Figure 5: Long Frame Sync (Shown with 8-bit Companded Sample) ..... 15

Figure 6: Short Frame Sync (Shown with 16-bit Sample) ..... 15

Figure 7: Multi-Slot Operation with Two Slots and 8-bit Companded Samples..... 16

Figure 8: GCI Interface ..... 16

Figure 9: 16-Bit Slot Length and Sample Formats..... 17

Figure 10: PCM Master Timing Long Frame Sync..... 19

Figure 11: PCM Master Timing Short Frame Sync ..... 19

Figure 12: PCM Slave Timing Long Frame Sync ..... 20

Figure 13: PCM Master Timing Short Frame Sync ..... 21

Figure 14: USB Connections for Self-Powered Mode ..... 23

Figure 15: USB Connections for Bus-Powered Mode ..... 24

Figure 16: Example EEPROM Connection with I<sup>2</sup>C Interface ..... 24

Figure 17: Design SPI for In-System Programming and Debug ..... 25

Figure 18: Reference Design..... 28

Figure 19: Mechanical Characteristic..... 29

Figure 20: Leave 20mm Clearance Space from the Module Built-in chip Antenna ..... 30

Figure 21: Recommended Reflow Profile..... 31



Figure 22: Product Packaging Information ..... 33  
Figure 23: Ordering Information ..... 33  
Figure 24: Radiation Patterns of Antenna ..... 37



## 1. Introduction

FLC-BTM403/FLC-BTMDC748 is a small form factor and highly economic Bluetooth radio module(class 1 or class 2) that allows OEM to add wireless capability to their products. The module supports multiple interfaces that make it simple to design into fully certified embedded Bluetooth solutions.

With FLC’s AT#™ programming interfaces, designers can easily customize their applications to support different Bluetooth profiles, such as SPP, DUN, HDP, and etc. class1 module supports Bluetooth® Enhanced Data Rate (EDR) and delivers up to 3 Mbps data rate for distances up to 300 meters with its integrated chip antenna, class 2 module supports 3Mbps data rate Transmission for distances up to 10 meters with its integrated chip antenna.

The module is an appropriate product for designers who want to add wireless capability to their products.

Note: According to the software divided into class1 and class2

### 1.1 Naming Declaration

New Naming	Old Naming
FLC-BTM403A	FLC-BTMDC748A(class1)
FLC-BTM403B	FLC-BTMDC748B(class1)
FLC-BTM403C	FLC-BTMDC748C(class2)

Table 1: Naming Declaration



## 1.2 Block Diagram

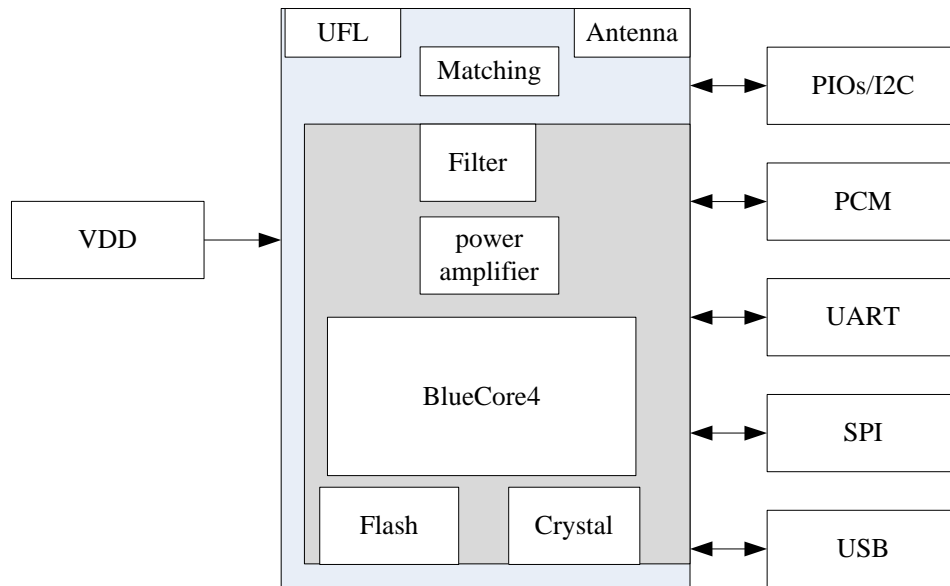

Figure 1: Block Diagram

## 1.3 Features

- Bluetooth v2.1+EDR
- UART and USB programming and data interfaces
- PCM digital audio interfaces
- 8MB on board flash
- Small form factor
- SMT pads for easy and reliable PCB mounting
- BQB/FCC/CE Certified
- RoHS compliant

## 1.4 Applications

- Cable replacement
- Bar code and RFID scanners
- Measurement and monitoring systems
- Industrial sensors and controls



- Medical devices
- Industrial PCs





## 2. General Specification

<b>Bluetooth Specification</b>	
Standard	Bluetooth2.1+EDR
Profiles	SPP, DUN, HDP, detailed profiles depends on the firmware
Frequency Band	2.402G ~ 2.480G
Maximum Data Rate	3Mbps
Antenna	Multilayer Ceramic Antenna or UFL port
RF Input Impedance	50 ohms
Baseband Crystal OSC	16MHz
Interface	UART, PIO, AIO, USB, SPI, PCM
Sensitivity	<a href="#">-84dBm@0.1%BER</a>
RF TX Power	+17dBm(class1) +4dbm(class2)
<b>Power</b>	
Supply Voltage	2.7 ~ 3.6V DC
Working Current	Depends on profiles, 22mA typical
Standby Current(Connected)	<2mA
<b>Operating Environment</b>	
Temperature	-40 ℃ to +85 ℃ for A and I grade -20 ℃ to +70 ℃ for V and C grade
Humidity	10%~90% Non-Condensing
<b>Certifications</b>	
	BQB/FCC/CE
<b>Environmental</b>	
	RoHS Compliant
<b>Dimension and Weight</b>	
Dimension	35.30mm×14.00mm×2.50mm
Weight	2.00g

Table 2: General Specification



### 3. Pin Definition

#### 3.1 Pin Configuration

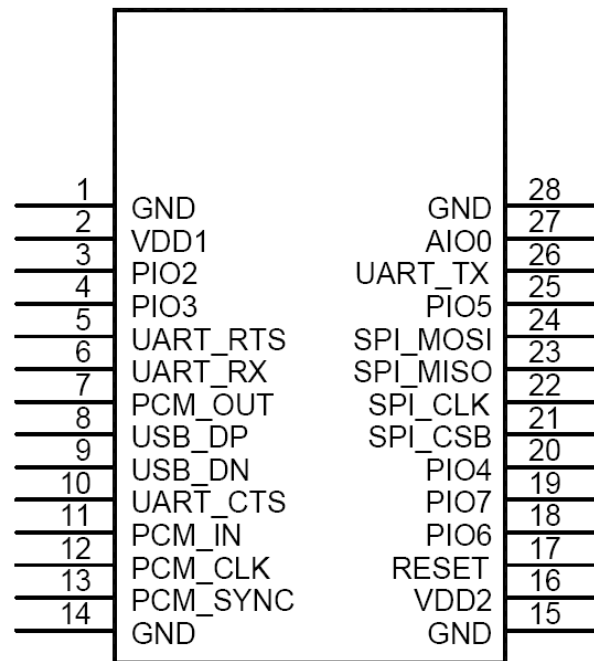

Figure 2: Pin Configuration

#### 3.2 Pin Definition

Pin	Symbol	I/O Type	Description
1	GND	Ground	Ground
2	VDD	3V3 power input	3V3 power input
3	PIO2	Bi-directional with programmable strength internal pull-up/down	Programmable input/output line
4	PIO3	Bi-directional with programmable strength internal pull-up/down	Programmable input/output line
5	UART_RTS	CMOS output, tri-state, with weak internal pull-up	UART request to send active low
6	UART_RX	CMOS input with weak internal pull-down	UART data input
7	PCM_OUT	Bi-directional	Synchronous Data Output



8	USB_DP	Bi-directional	USB data plus with selectable internal 1.5Kohm pull-up resistor
9	USB_DN	Bi-directional	USB data minus
10	UART_CTS	CMOS output, tri-state, with weak internal pull-down	UART clear to send active low
11	PCM_IN	CMOS Input	Synchronous Data Input
12	PCM_CLK	Bi-directional	Synchronous Data Clock
13	PCM_SYNC	Bi-directional	Synchronous Data Sync
14	GND	Ground	Ground
15	GND	Ground	Ground
16	VDD	3.3V power input	3.3V power input
17	RESET	CMOS input with weak internal pull-down	Reset if high. Input debounced so must be high for >5ms to cause a reset
18	PIO6	Bi-directional with programmable strength internal pull-up/down	Programmable input/output line
19	PIO7	Bi-directional with programmable strength internal pull-up/down	Programmable input/output line
20	PIO4	Bi-directional with programmable strength internal pull-up/down	Programmable input/output line
21	SPI_CSB	CMOS input with weak internal pull-up	Chip select for Synchronous Serial Interface active low
22	SPI_CLK	input with weak internal pull-down	Serial Peripheral Interface clock
23	SPI_MISO	CMOS output, tri-state, with weak internal pull-down	Serial Peripheral Interface output
24	SPI_MOSI	CMOS input, with weak internal pull-down	Serial Peripheral Interface input
25	PIO5	Bi-directional with programmable strength internal pull-up/down	Programmable input/output line
26	UART_TX	CMOS input with weak internal pull-down	UART data output
27	AIO0	Bi-directional	Programmable input/output line
28	GND	Ground	Ground

Table 3: Pin Definition



## 4. Physical Interfaces

### 4.1 Power Supply

The transient response of the regulator is important. If the power rails of the module are supplied from an external voltage source, the transient response of any regulator used should be 20 $\mu$ s or less. It is essential that the power rail recovers quickly.

### 4.2 Reset

The module may be reset from several sources: RESET pin, power-on reset, a UART break character or via a software configured watchdog timer.

The RESET pin is an active high reset and is internally filtered using the internal low frequency clock oscillator. A reset will be performed between 1.5 and 4.0ms following RESET being active. It is recommended that RESET be applied for a period greater than 5ms.

The module has an internal reset circuitry, which keeps reset pin active until supply voltage has reached stability in the start up. This ensures that supply for the flash memory inside the module will reach stability before BC4 chip fetches instructions from it. Pull-up or pull-down resistor should not be connected to the reset pin to ensure proper star up of module.

At reset the digital I/O pins are set to inputs for bi-directional pins and outputs are tri-state. The PIOs have weak pull-downs.

Pin Name / Group	Pin Status on Reset
USB_DP	Input with PD
USB_DN	Input with PD
UART_RX	Input with PD
UART_CTS	Input with PD
UART_TX	Tri-state output with PU
UART_RTS	Tri-state output with PU
SPI_MOSI	Input with PD
SPI_CLK	Input with PD
SPI_CSB	Input with PU
SPI_MISO	Tri-state output with PD
PCM_CLK	Input with PD
PCM_SYNC	Input with PD
PCM_IN	Input with PD
PCM_OUT	Tri-state with PD
RESETB	Input with PU
PIOs	Input with weak PD
AIOs	Output, driving low
RF-IN	High impedance

Table 4: Pin Status on Reset



Note: Pull-up (PU) and pull-down (PD) default to weak values unless specified otherwise.

### 4.3 Digital Audio Interfaces

The module has offered PCM digital audio interface.

PCM is a standard method used to digitize audio (particularly voice) for transmission over digital communication channels. Through its PCM interface, the module has hardware support for continual transmission and reception of PCM data, thus reducing processor overhead for applications. The module offers a bi-directional digital audio interface that routes directly into the baseband layer of the on-chip firmware. It does not pass through the HCI protocol layer.

Hardware on the module allows the data to be sent to and received from a SCO connection. Up to three SCO connections can be supported by the PCM interface at any one time.

The module can operate as the PCM interface master generating an output clock of 128, 256 or 512kHz. When configured as PCM interface slave, it can operate with an input clock up to 2048kHz. The module is compatible with a variety of clock formats, including Long Frame Sync, Short Frame Sync and GCI timing environments.

It supports 13-bit or 16-bit linear, 8-bit  $\mu$ -law or A-law companded sample formats at 8k samples/s and can receive and transmit on any selection of three of the first four slots following PCM\_SYNC.

The module interfaces directly to PCM audio devices including the following:

- Qualcomm MSM 3000 series and MSM 5000 series CDMA baseband devices
- OKI MSM7705 four channels A-law and  $\mu$ -law CODEC
- Motorola MC145481 8-bit A-law and  $\mu$ -law CODEC
- Motorola MC145483 13-bit linear CODEC
- STW 5093 and 5094 14-bit linear CODECs

The module is also compatible with the Motorola SSI™ interface.

#### 4.3.1 PCM Interface Master/Slave

When PCM is configured as a master, the module generates PCM\_CLK and PCM\_SYNC.

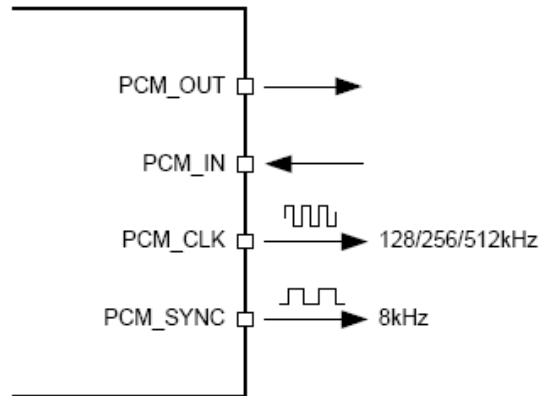

Figure 3: Configured PCM as a Master

When PCM is configured as the slave, the module accepts PCM\_CLK rates up to 2048kHz.

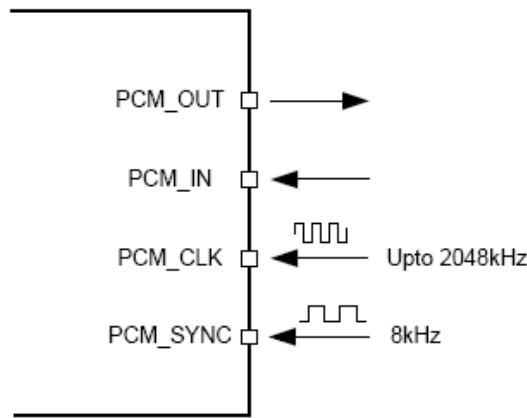

Figure 4: Configured PCM as a Slave

### 4.3.2 Long Frame Sync

Long Frame Sync is the name given to a clocking format that controls the transfer of PCM data words or samples. In Long Frame Sync, the rising edge of PCM\_SYNC indicates the start of the PCM word. When the module is configured as PCM master, generating PCM\_SYNC and PCM\_CLK, then PCM\_SYNC is 8-bits long. When the module is configured as PCM Slave, PCM\_SYNC may be from two consecutive falling edges of PCM\_CLK to half the PCM\_SYNC rate, i.e., 62.5  $\mu$ s long.

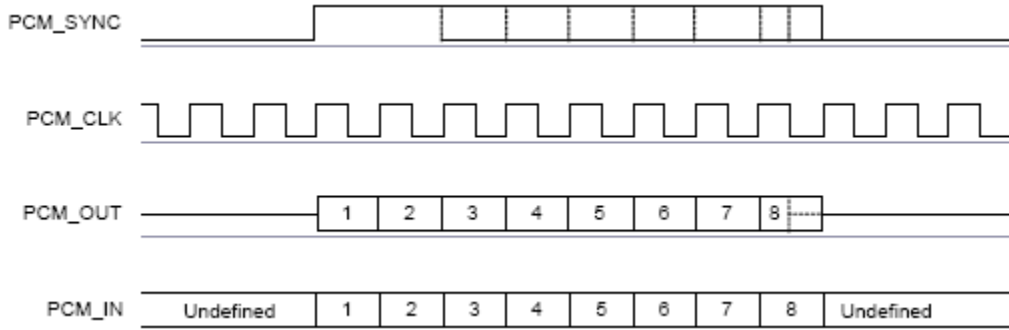

Figure 5: Long Frame Sync (Shown with 8-bit Companded Sample)

### 4.3.3 Short Frame Sync

In Short Frame Sync, the falling edge of PCM\_SYNC indicates the start of the PCM word. PCM\_SYNC is always one clock cycle long.

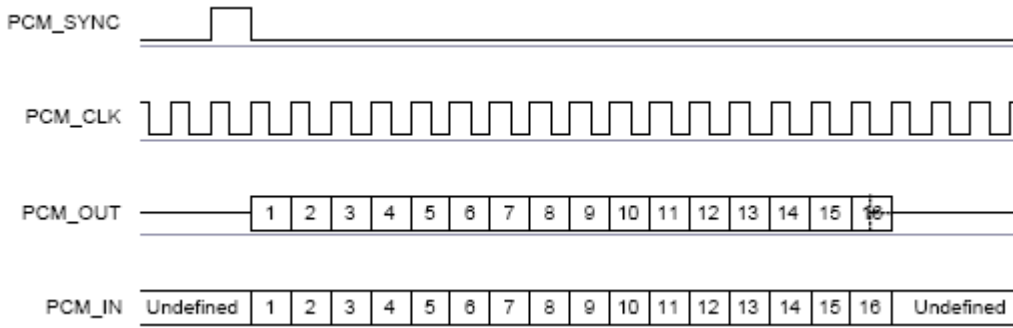

Figure 6: Short Frame Sync (Shown with 16-bit Sample)

As with Long Frame Sync, the module samples PCM\_IN on the falling edge of PCM\_CLK and transmits PCM\_OUT on the rising edge. PCM\_OUT may be configured to be high impedance on the falling edge of PCM\_CLK in the LSB position or on the rising edge.

### 4.3.4 Multi-slot Operation

More than one SCO connection over the PCM interface is supported using multiple slots. Up to three SCO connections can be carried over any of the first four slots.

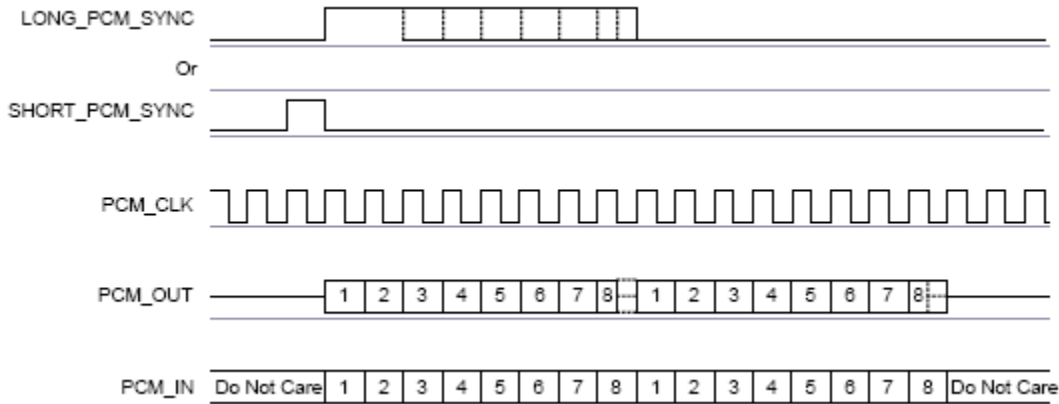

Figure 7: Multi-Slot Operation with Two Slots and 8-bit Companded Samples

### 4.3.5 GCI Interface

The module is compatible with the General Circuit Interface (GCI), a standard synchronous 2B+D ISDN timing interface. The two 64Kbps B channels can be accessed when this mode is configured.

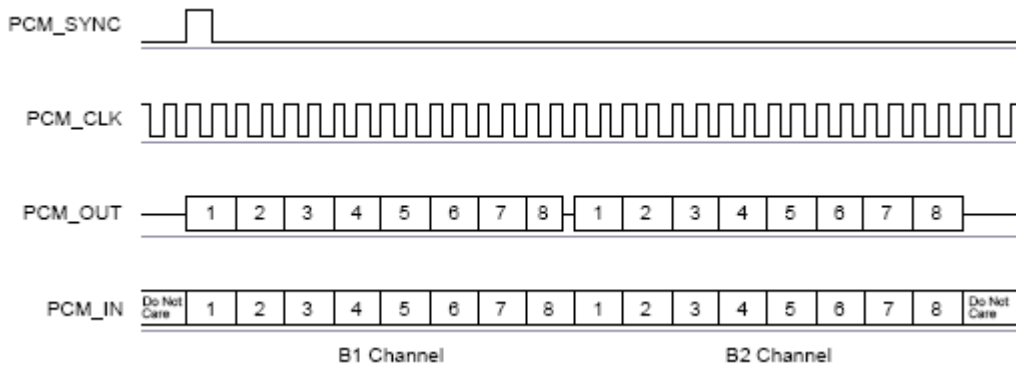

Figure 8: GCI Interface

The start of a frame is indicated by the rising edge of PCM\_SYNC and runs at 8kHz. With the module in slave mode, the frequency of PCM\_CLK can be up to 4.096MHz.

### 4.3.6 Slots and Sample Formats

The module can receive and transmit on any selection of the first four slots following each sync pulse. Slot durations can be either 8 or 16 clock cycles. Durations of 8 clock cycles may only be used with 8-bit sample formats. Durations of 16 clocks may be used with 8-bit, 13-bit or 16-bit sample formats. The module supports 13-bit linear, 16-bit linear and 8-bit  $\mu$ -law or A-law sample formats. The sample rate is 8k samples/s. The bit order may be little or big endian. When 16-bit slots are used, the 3 or 8 unused bits in each slot may be filled with sign extension, padded with zeros or a programmable 3-bit audio attenuation compatible with some Motorola CODECs.



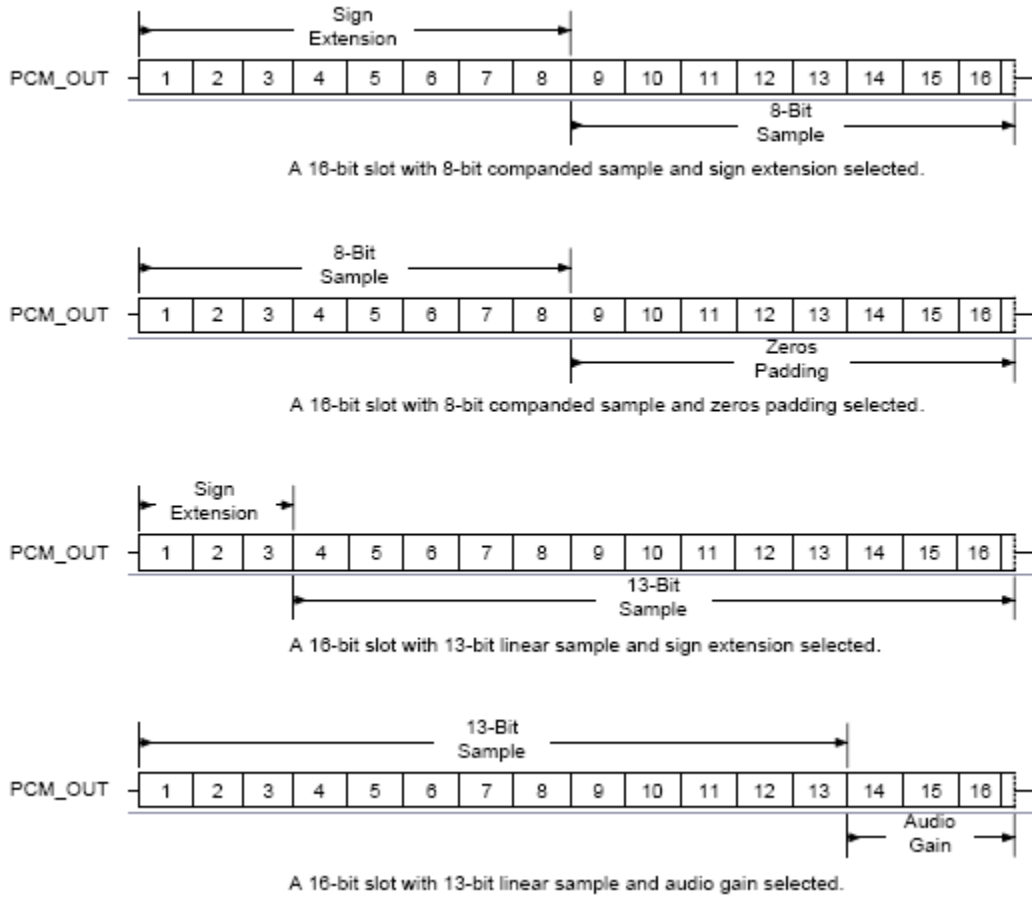

Figure 9: 16-Bit Slot Length and Sample Formats

### 4.3.7 Additional Features

The module has a mute facility that forces PCM\_OUT to be 0. In master mode, PCM\_SYNC may also be forced to 0 while keeping PCM\_CLK running which some CODECS use to control power down.

### 4.3.8 PCM Timing Information

Symbol	Parameter		Min	Typical	Max	Unit
fmclk	PCL_CLK Frequency	4MHz DDS generation. Selection of frequency is programmable.	-	128	-	kHz
				256		
				512		



		48MHz DDS generation. Selection of frequency is programmable.	2.9		-	kHz
-	PCM_SYNC frequency		-	8		kHz
tmcclk <sup>(a)</sup>	PCM_CLK high	4MHz DDS generation	980	-	-	ns
tmcclk <sup>(a)</sup>	PCM_CLK low	4MHz DDS generation	730	-		ns
-	PCM_CLK jitter	48MHz DDS generation			21	ns pk-pk
tdmclkynch	Delay time from PCM_CLK high to PCM_SYNC high		-	-	20	ns
tdmclkpout	Delay time from PCM_CLK high to valid PCM_OUT		-	-	20	ns
tdmclkynch	Delay time from PCM_CLK low to PCM_SYNC low (Long Frame Sync only)		-	-	20	ns
tdmclkynch	Delay time from PCM_CLK high to PCM_SYNC low		-	-	20	ns
tdmclkpoutz	Delay time from PCM_CLK low to PCM_OUT high impedance		-	-	20	ns
tdmclkhpoutz	Delay time from PCM_CLK high to PCM_OUT high impedance		-	-	20	ns
tsupinclk	Set-up time for PCM_IN valid to PCM_CLK low		30	-	-	ns
thpinclk	Hold time for PCM_CLK low to PCM_IN invalid		10	-	-	ns

Table 5: PCM Master Timing

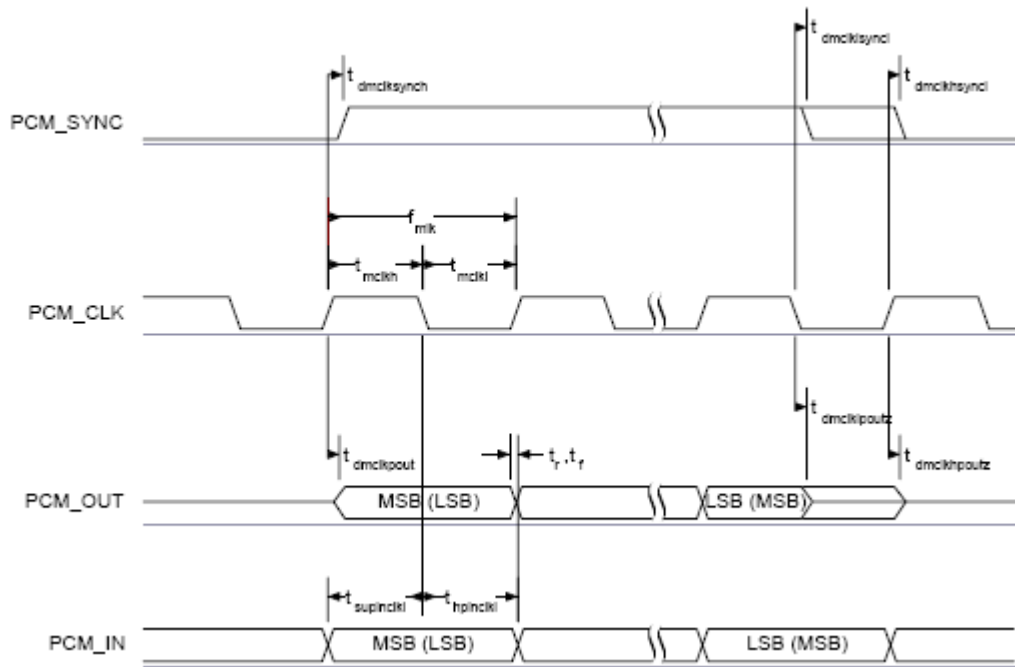

Figure 10: PCM Master Timing Long Frame Sync

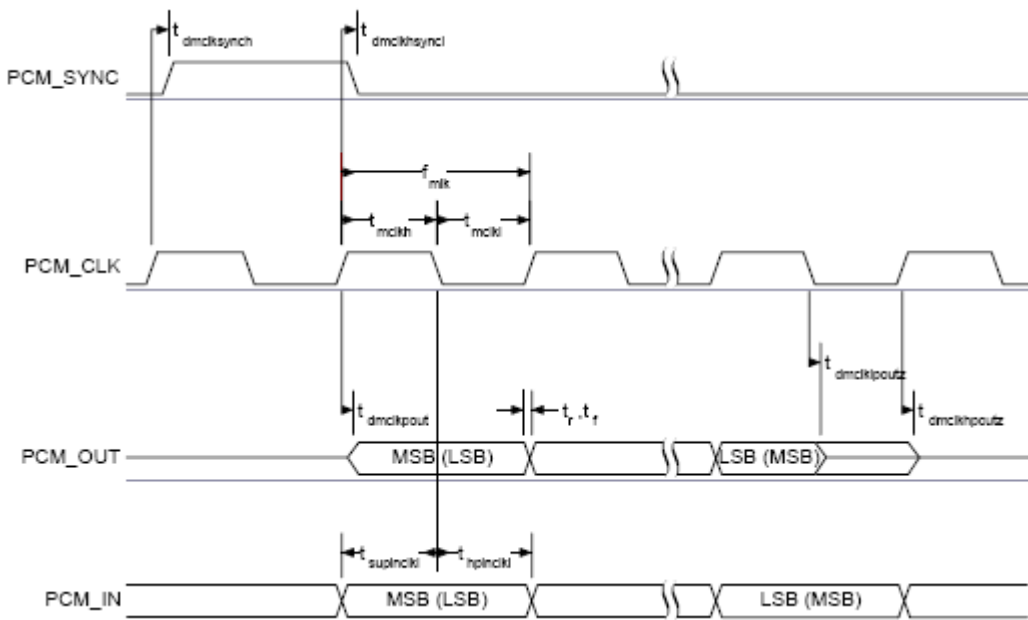

Figure 11: PCM Master Timing Short Frame Sync

Symbol	Parameter	Min	Typical	Max	Unit
fsclock	PCM clock frequency (Slave mode: input)	64	-	2048	kHz



f <sub>clk</sub>	PCM clock frequency (GCI mode)	128	-	4096	kHz
t <sub>sclk</sub> l	PCM_CLK low time	200	-	-	ns
t <sub>sclk</sub> h	PCM_CLK high time	200	-	-	ns
t <sub>hsc</sub> lksynch	Hold time from PCM_CLK low to PCM_SYNC high	30	-	-	ns
t <sub>sus</sub> clksynch	Set-up time for PCM_SYNC high to PCM_CLK low	30	-	-	ns
t <sub>d</sub> pout	Delay time from PCM_SYNC or PCM_CLK whichever is later, to valid PCM_OUT data (Long Frame Sync only)	-	-	20	ns
t <sub>d</sub> sclkh <sub>pout</sub>	Delay time from CLK high to PCM_OUT valid data	-	-	20	ns
t <sub>d</sub> poutz	Delay time from PCM_SYNC or PCM_CLK low, whichever is later, to PCM_OUT data line high impedance	-	-	20	ns
t <sub>sup</sub> insclk	Set-up time for PCM_IN valid to CLK low	30	-	-	ns
t <sub>hp</sub> insclk	Hold time for PCM_CLK low to PCM_IN invalid	30	-	-	ns

Table 6: PCM Slave Timing

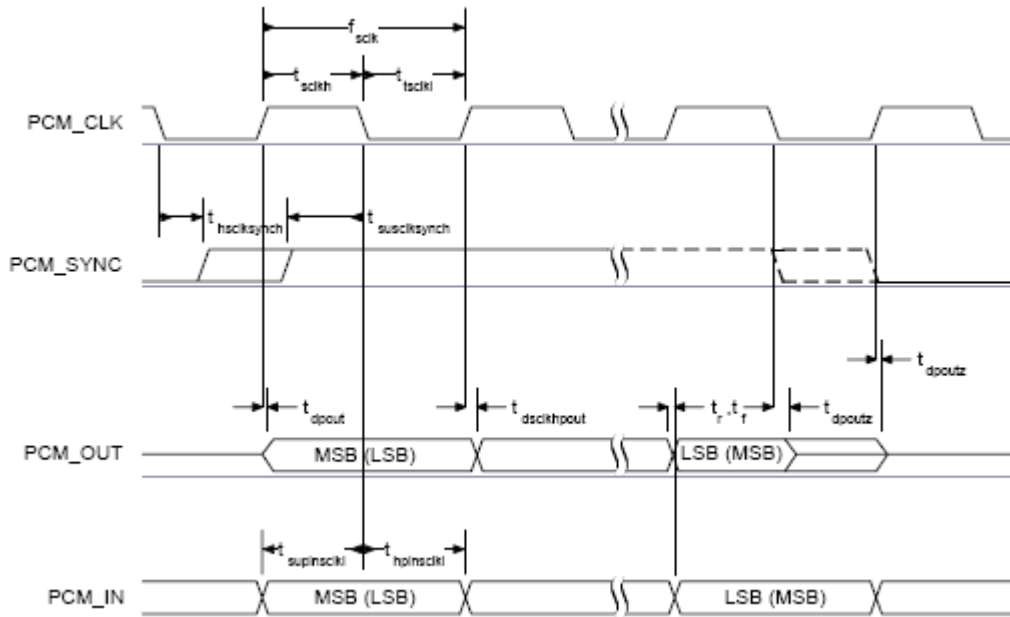

Figure 12: PCM Slave Timing Long Frame Sync

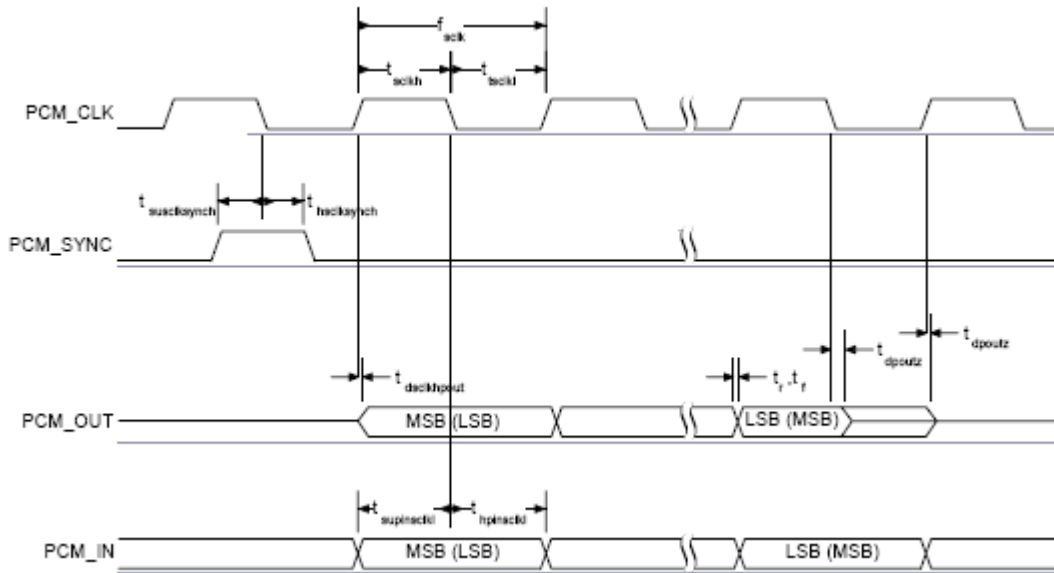

Figure 13: PCM Master Timing Short Frame Sync

### 4.4 RF Interface

The module integrates a balun filter. The user can connect a 50ohms antenna directly to the RF port.

### 4.5 General Purpose Analogue IO

The general purpose analogue IO can be configured as ADC inputs by software. Do not connect them if not use.

### 4.6 General Purpose Digital IO

The general purpose digital IO can be configured by software to have various functions such as button, LED or interrupt signals to host controller. Do not connect them if not use.

### 4.7 Serial Interfaces

#### 4.7.1 UART

This is a standard Universal Asynchronous Receiver Transmitter (UART) interface for communicating with other serial devices. Four signals UART\_TX, UART\_RX, UART\_CTS, and UART\_RTS are used to implement the UART function, UART\_CTS, UART\_RTS can be used to implement hardware flow control. PIO2 and PIO3 can be configured as DTR and RTS.



Parameter		Possible Values
Baud Rate	Minimum	1200 baud ( $\leq 2\%$ Error)
		9600 baud ( $\leq 1\%$ Error)
	Maximum	3M baud ( $\leq 1\%$ Error)
Flow Control		RTS/CTS or None
Parity		None, Odd or Even
Number of Stop Bits		1 or 2
Bits per Byte		8

Table 7: Possible UART Settings

## 4.7.2 USB

There is a full speed (12M bits/s) USB interface for communicating with other compatible digital devices. The module acts as a USB peripheral, responding to request from a master host controller, such as a PC.

The module features an internal USB pull-up resistor. This pulls the USB\_DP pin weakly high when module is ready to enumerate. It signals to the USB master that it is a full speed (12Mbit/s) USB device. The USB internal pull-up is implemented as a current source, and is compliant with section 7.1.5 of the USB specification v1.2. The internal pull-up pulls USB\_DP high to at least 2.8V when loaded with a  $15k\Omega \pm 5\%$  pull-down resistor (in the hub/host) when  $VDD = 3.1V$ . This presents a Thevenin resistance to the host of at least  $900\Omega$ . Alternatively, an external  $1.5k\Omega$  pull-up resistor can be placed between a PIO line and DP on the USB cable.

### 4.7.2.1 Self-Powered Mode

In self-powered mode, the module is powered from its own power supply and not from the VBUS (5V) line of the USB cable. It draws only a small leakage current (below 0.5mA) from VBUS on the USB cable. This is the easier mode for which to design, as the design is not limited by the power that can be drawn from the USB hub or root port. However, it requires that VBUS be connected to module via a resistor network (Rvb1 and Rvb2), so the module can detect when VBUS is powered up. The module will not pull USB\_DP high when VBUS is off.

Self-powered USB designs (powered from a battery or LDO) must ensure that a PIO line is allocated for USB pull-up purposes. A  $1.5K\Omega$  5% pull-up resistor between USB\_DP and the selected PIO line should be fitted to the design. Failure to fit this resistor may result in the design failing to be USB compliant in self-powered mode. The internal pull-up in the module is only suitable for bus-powered USB devices, e.g., dongles.

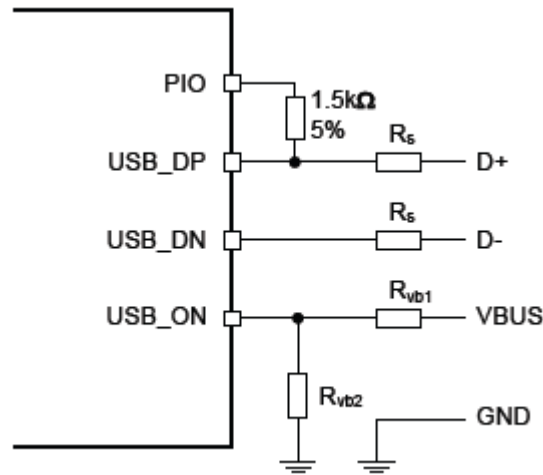

Figure 14: USB Connections for Self-Powered Mode

**Note:**

USB\_ON is shared with the module PIO terminals.

Identifier	Value	Function
$R_s$	27 $\Omega$ Nominal	Impedance matching to USB cable
$R_{vb1}$	22k $\Omega$ 5%	VBUS ON sense divider
$R_{vb2}$	47k $\Omega$ 5%	VBUS ON sense divider

Table 8: USB Interface Component Values

**4.7.2.2 Bus-Powered Mode**

In bus-powered mode, the application circuit draws its current from the 5V VBUS supply on the USB cable. The module negotiates with the PC during the USB enumeration stage about how much current it is allowed to consume. For Class 2 Bluetooth applications, FLC recommends that the regulator used to derive 3.3V from VBUS is rated at 100mA average current and should be able to handle peaks of 120mA without foldback or limiting. In bus-powered mode, the module requests 100mA during enumeration. For Class 1 Bluetooth applications, the USB power descriptor should be altered to reflect the amount of power required. This is higher than for a Class 2 application due to the extra current drawn by the Transmit RF PA. When selecting a regulator, be aware that VBUS may go as low as 4.4V. The inrush current (when charging reservoir and supply decoupling capacitors) is limited by the USB specification. See USB Specification v1.1, section 7.2.4.1. Some applications may require soft start circuitry to limit inrush current if more than 10 $\mu$ F is present between VBUS and GND.

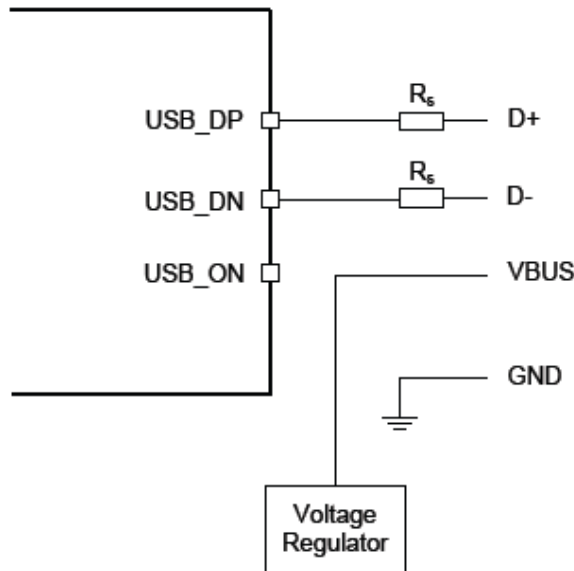

Figure 15: USB Connections for Bus-Powered Mode

### 4.7.3 I<sup>2</sup>C

PIO5, PIO7 and PIO6 can be used to form a master I<sup>2</sup>C interface. The interface is formed using software to drive these lines. It is suited only to relatively slow functions such as driving a LCD, Keyboard, scanner or EEPROM. In the case, PIO lines need to be pulled up through 2.2Kohm resistors.

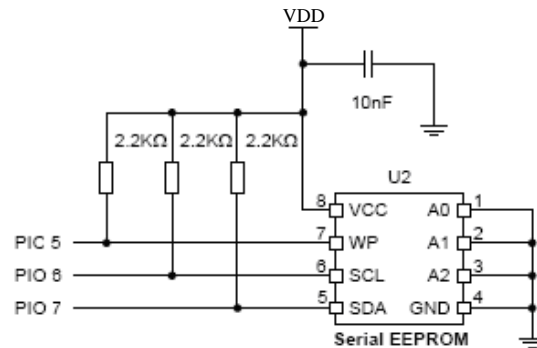

Figure 16: Example EEPROM Connection with I<sup>2</sup>C Interface

### 4.7.4 SPI

The synchronous serial port interface (SPI) can be used for system debugging. It can also be used for in-system programming for the flash memory within the module. SPI interface uses the SPI\_MOSI, SPI\_MISO, SPI\_CSB and SPI\_CLK pins. Testing points for the SPI interface are reserved on board in case that the firmware shall be updated during manufacture.

The module operates as a slave and thus SPI\_MISO is an output of the module. SPI\_MISO is not in high-impedance state when SPI\_CSB is pulled high. Instead, the module outputs 0 if the processor is





running and 1 if it is stopped. Thus the module should NOT be connected in a multi-slave arrangement by simple parallel connection of slave SPI\_MISO lines. The SPI interface is needed when debugging the Bluetooth functions so please leave test points/pads as shown in **Figure 17** on PCB.

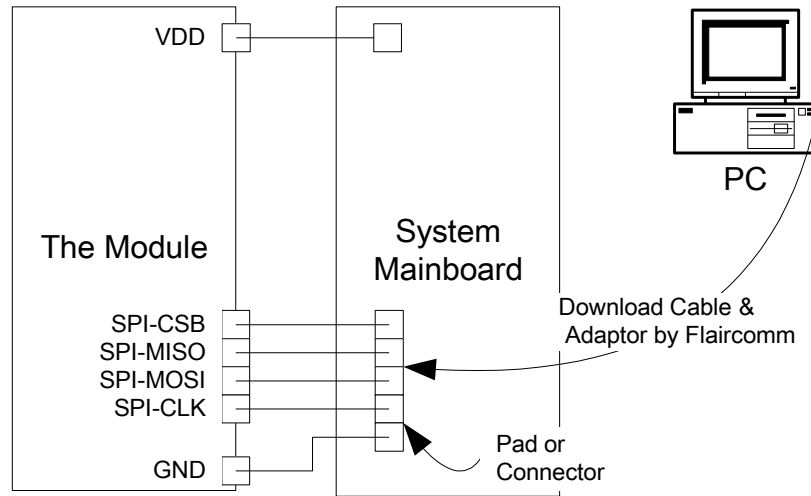

**Figure 17: Design SPI for In-System Programming and Debug**



## 5. Electrical Characteristic

### 5.1 Absolute Maximum Rating

Rating	Min	Max	Unit
Storage Temperature	-40	+120	°C
Operating Temperature (for A and I grade)	-40	+85	°C
Operating Temperature (for V and C grade)	-20	+70	°C
PIO/AIO Voltage	-0.4	+3.6	V
VDD Voltage	-0.4	+3.7	V
USB_DP/USB_DN Voltage	-0.4	+3.6	V
Other Terminal Voltages except RF	-0.4	VDD+0.4	V

Table 9: Absolute Maximum Rating Recommended Operating Conditions

### 5.2 Recommend operation conditions

Operating Condition	Min	Typical	Max	Unit
Storage Temperature	-40	--	+85	°C
Operating Temperature Range (for A and I grade)	-40	--	+85	°C
Operating Temperature Range (for V and C grade)	-20	--	+70	°C
VDD Voltage	+2.7	+3.3	+3.6	V

Table 10: Recommended Operating Conditions

### 5.3 Power consumptions

Operating Condition	Min	Typical	Max	Unit
Radio On* (Discovery)		23		mA
Radio On* ( Inquiry window time)		73		mA
Connected Idle (No Sniff)		20		mA
Connected with data transfer	6	10	25	mA

Table 11: Power consumptions

\*If in SLAVE mode there are bursts of radio ON time which vary with the windows. Depending on how you set the windows that determines your average current.



## 5.4 Input/output Terminal Characteristics

### 5.4.1 Digital Terminals

Supply Voltage Levels	Min	Typical	Max	Unit
<b>Input Voltage Levels</b>				
V <sub>IL</sub> input logic level low	-0.4	-	+0.8	V
V <sub>IH</sub> input logic level high	0.7VDD	-	VDD+0.4	V
<b>Output Voltage Levels</b>				
V <sub>OL</sub> output logic level low, I <sub>OL</sub> = 4.0mA	-	-	0.4	V
V <sub>OH</sub> output logic level high, I <sub>OH</sub> = -4.0mA	VDD-0.2	-	-	V
<b>Input and Tri-state Current</b>				
With strong pull-up	-100	-40	-10	μA
With strong pull-down	10	40	100	μA
With weak pull-up	-5	-1.0	-0.2	μA
With weak pull-down	-0.2	+1.0	5.0	μA
I/O pad leakage current	-1	0	+1	μA
C <sub>I</sub> Input Capacitance	1.0	-	5.0	pF

Table 12: Digital Terminal

### 5.4.2 USB

USB Terminals	Min	Typical	Max	Unit
<b>Input Threshold</b>				
V <sub>IL</sub> input logic level low	-	-	0.3VDD	V
V <sub>IH</sub> input logic level high	0.7VDD	-	-	V
<b>Input Leakage Current</b>				
GND < V <sub>IN</sub> < VDD <sup>(a)</sup>	-1	1	5	μA
C <sub>I</sub> Input capacitance	2.5	-	10.0	pF
<b>Output Voltage Levels to Correctly Terminated USB Cable</b>				
V <sub>IL</sub> output logic level low	0.0	-	0.2	V
V <sub>IH</sub> output logic level high	2.8	-	VDD	V

Table 13: USB Terminal

(a) Internal USB pull-up disabled



## 6. Reference Design

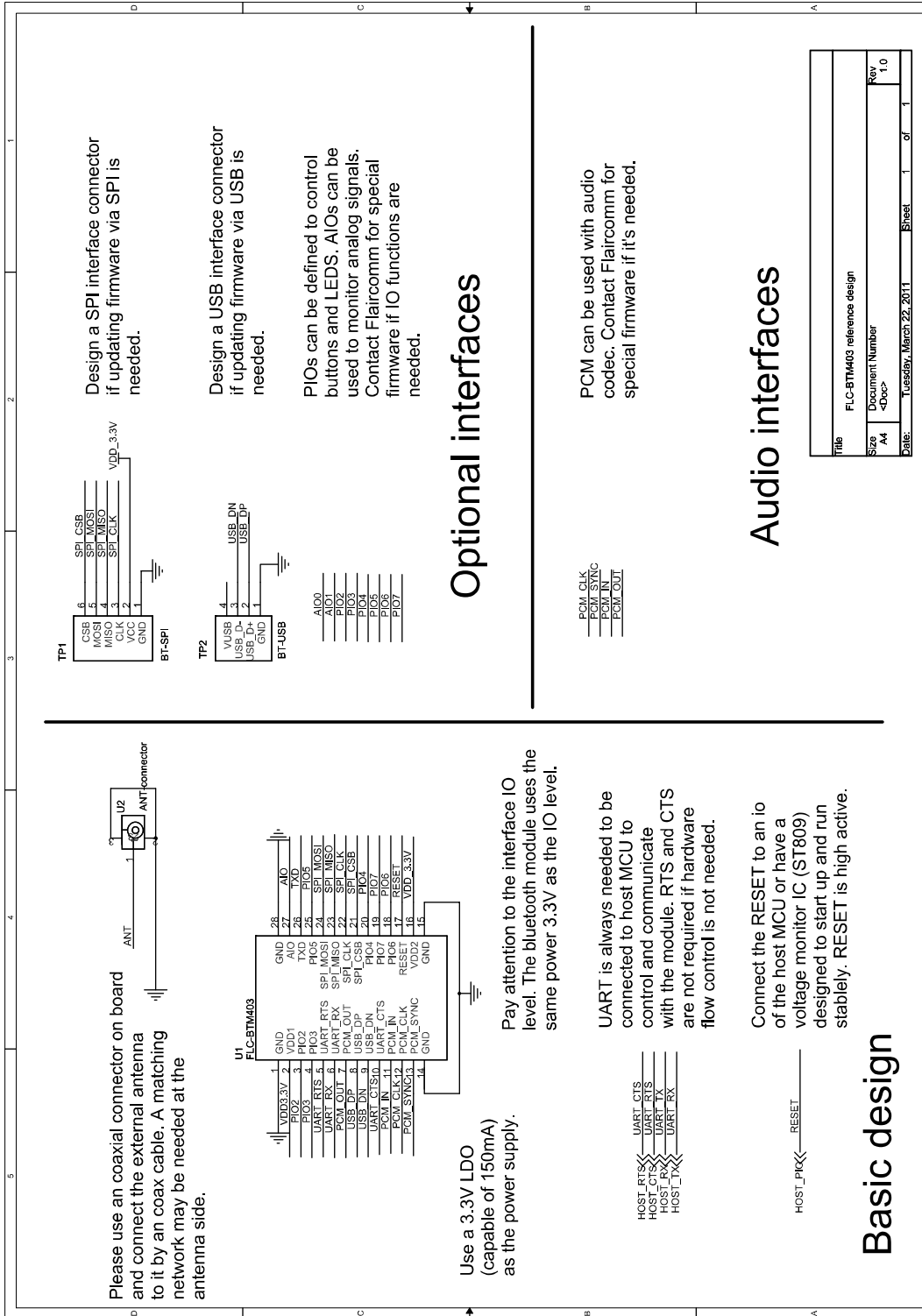

Figure 18: Reference Design



### 7. Mechanical Characteristic

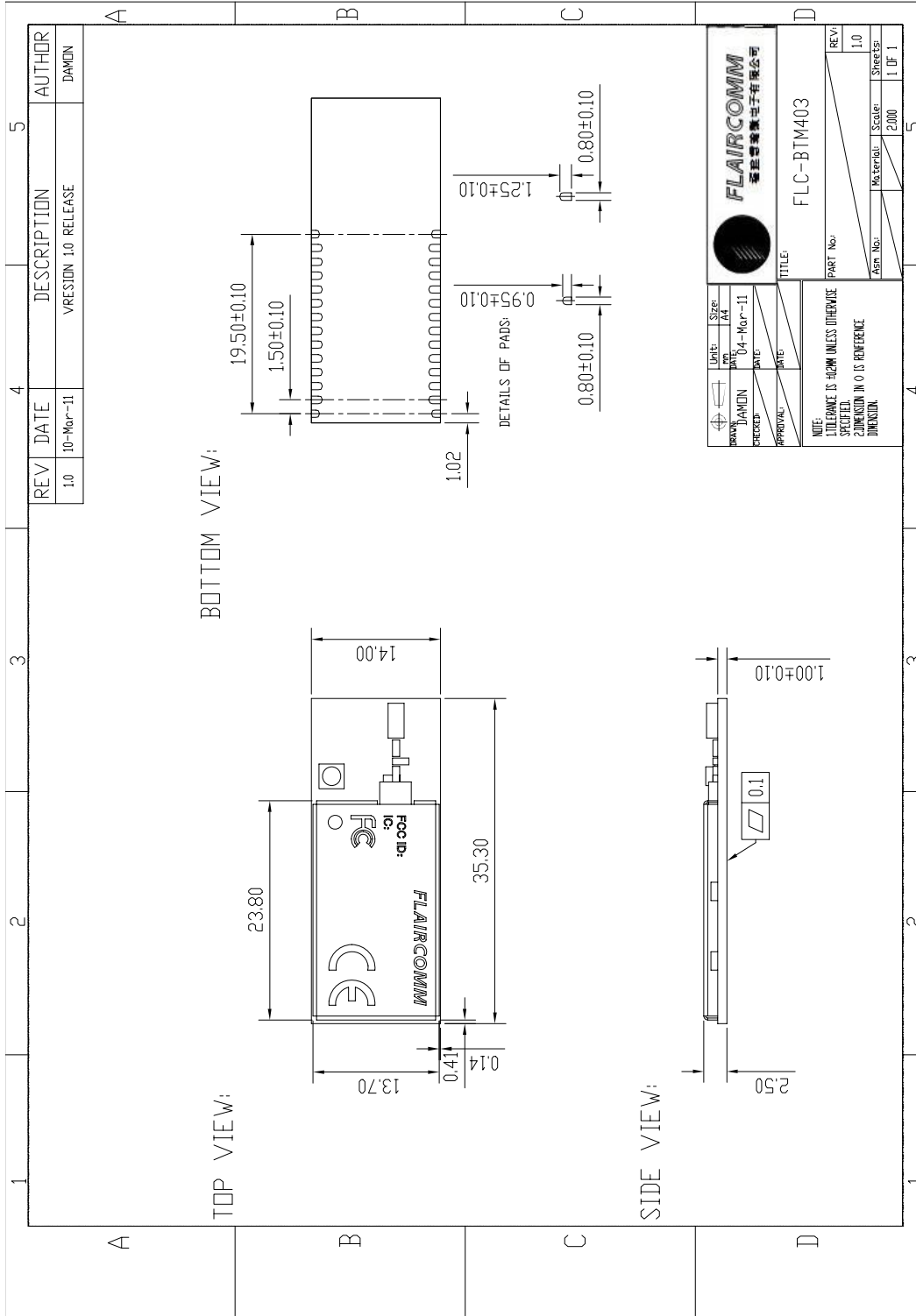

Figure 19: Mechanical Characteristic



## 8. Recommended PCB Layout and Mounting Pattern

A very important factor in achieving maximum Bluetooth performance is the placement of a module with on-board antenna designs onto the carrier board and corresponding PCB layout. There should be no any trace, ground and vias in the area of the carrier board underneath the module's on-board antenna section as indicated in Figure 20. Antenna portion of the module must be placed at least 20mm away from any metal part and the antenna should not be covered by any piece of metal. The antenna of the module MUST be kept as far from potential noise sources as possible and special care must also be taken with placing the module in proximity to circuitry that can emit heat. The RF part of the module is very sensitive to temperature and sudden changes can have an adverse impact on performance.

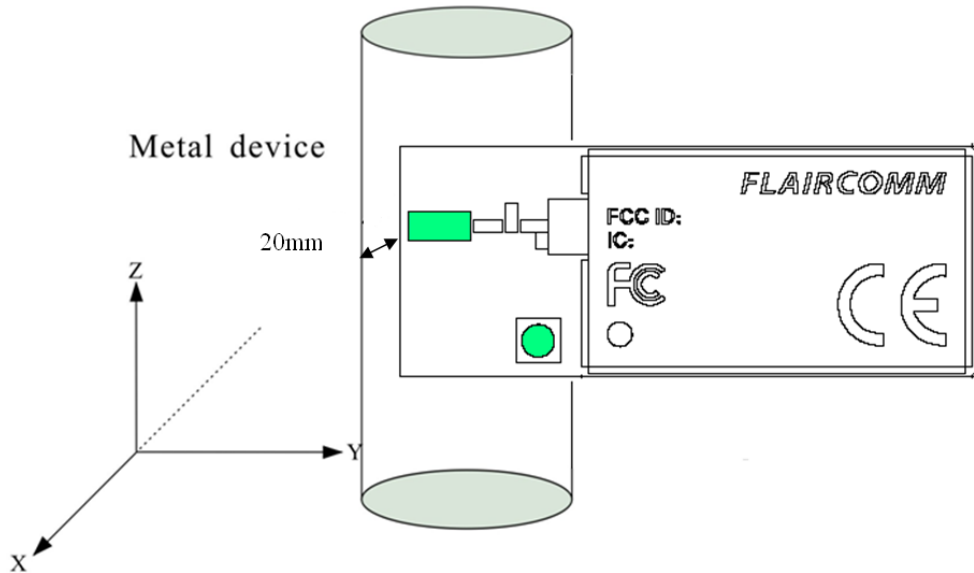

Figure 20: Leave 20mm Clearance Space from the Module Built-in chip Antenna



## 9. Recommended Reflow Profile

The soldering profile depends on various parameters necessitating a set up for each application. The data here is given only for guidance on solder reflow.

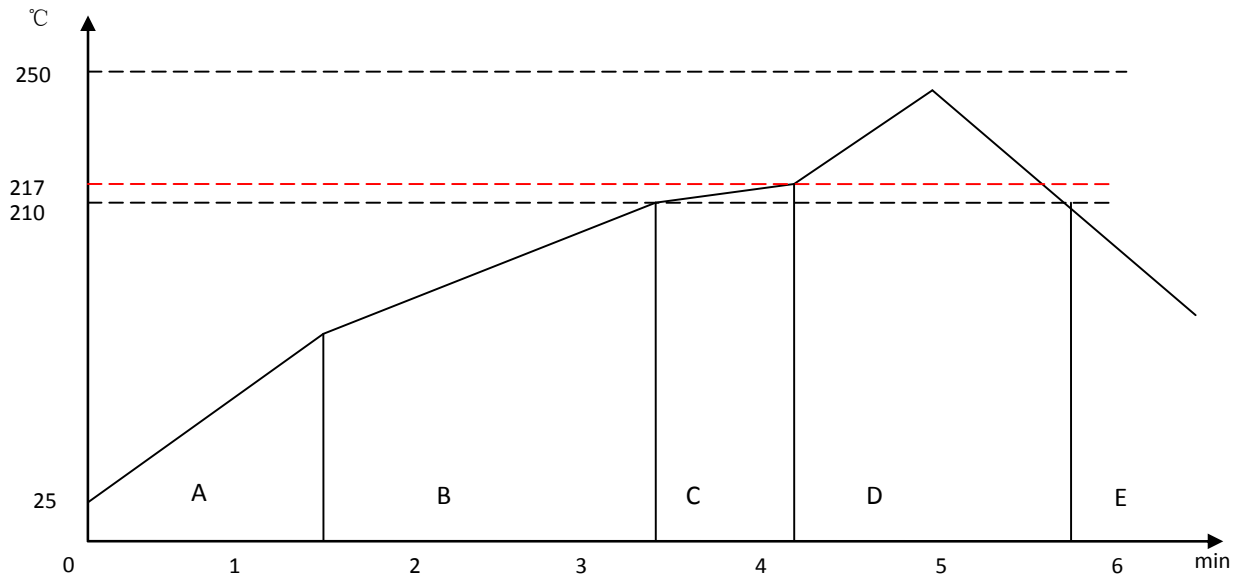

Figure 21: Recommended Reflow Profile

**Pre-heat zone (A)** — This zone raises the temperature at a controlled rate, **typically 0.5 – 2 °C/s**. The purpose of this zone is to preheat the PCB board and components to 120 ~ 150 °C. This stage is required to distribute the heat uniformly to the PCB board and completely remove solvent to reduce the heat shock to components.

**Equilibrium Zone 1 (B)** — In this stage the flux becomes soft and uniformly encapsulates solder particles and spread over PCB board, preventing them from being re-oxidized. Also with elevation of temperature and liquefaction of flux, each activator and rosin get activated and start eliminating oxide film formed on the surface of each solder particle and PCB board. **The temperature is recommended to be 150° to 210° for 60 to 120 second for this zone.**

**Equilibrium Zone 2 (c) (optional)** — In order to resolve the upright component issue, it is recommended to keep the temperature in 210 – 217 ° for about 20 to 30 second.

**Reflow Zone (D)** — The profile in the figure is designed for Sn/Ag3.0/Cu0.5. It can be a reference for other lead-free solder. The peak temperature should be high enough to achieve good wetting but not so high as to cause component discoloration or damage. Excessive soldering time can lead to intermetallic growth which can result in a brittle joint. The recommended peak temperature ( $T_p$ ) is 230 ~ 250 °C. The soldering time should be 30 to 90 second when the temperature is above 217 °C.

**Cooling Zone (E)** — The cooling rate should be fast, to keep the solder grains small which will give a longerlasting joint. **Typical cooling rate should be 4 °C.**







Figure 22: Product Packaging Information

## 10.2 Ordering information

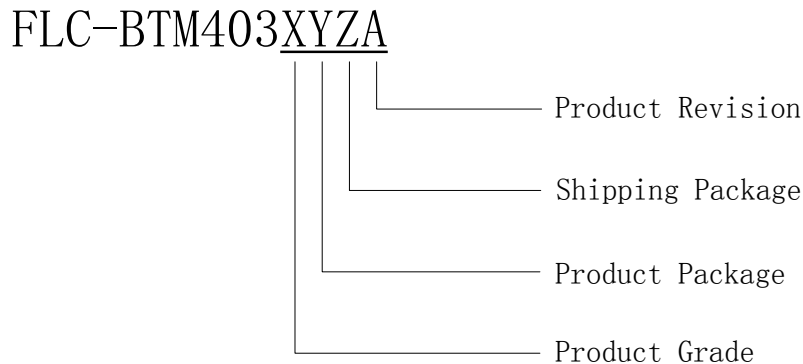

Figure 23: Ordering Information

### 10.2.1 Product Revision

Product Revision	Description	Availability
A	Multilayer Ceramic Antenna ( Class 1)	Yes
B	UFL connector (Class 1)	Yes
C	Multilayer Ceramic Antenna ( Class 2)	Yes

Table 14: Product Revision

### 10.2.2 Shipping Package

Shipping Package	Description	Quantity	Availability
0	Spongy Cushion In Box	—	No
1	Plastic Tray In Box	—	No
2	Tape	800x5 =4000	Yes

Table 15: Shipping Package

### 10.2.3 Product Package

Product Package	Description	Availability
Q	QFN	Yes
L	LGA	No
B	BGA	No
C	Connector	No

Table 16: Product Package

### 10.2.4 Product Grade

Product Grade	Description	Availability
C	Consumer	No
I	Industrial	Yes
V	Automobile After-Market	Yes



---

---

A	Automobile Before-Market	No
---	--------------------------	----

**Table 17: Product Grade**



## **11. Cautions & Warnings**

### **11.1 FCC Statement**

1. This device complies with Part 15 of the FCC Rules. Operation is subject to the following two conditions:

- (1) This device may not cause harmful interference.
- (2) This device must accept any interference received, including interference that may cause undesired operation.

2. Changes or modifications not expressly approved by the party responsible for compliance could void the user's authority to operate the equipment.

NOTE: This equipment has been tested and found to comply with the limits for a Class B digital device, pursuant to Part 15 of the FCC Rules. These limits are designed to provide reasonable protection against harmful interference in a residential installation.

This equipment generates uses and can radiate radio frequency energy and, if not installed and used in accordance with the instructions, may cause harmful interference to radio communications. However, there is no guarantee that interference will not occur in a particular installation. If this equipment does cause harmful interference to radio or television reception, which can be determined by turning the equipment off and on, the user is encouraged to try to correct the interference by one or more of the following measures:

- Reorient or relocate the receiving antenna.
- Increase the separation between the equipment and receiver.
- Connect the equipment into an outlet on a circuit different from that to which the receiver is connected.
- Consult the dealer or an experienced radio/TV technician for help.

This radio module must not be installed to co-locate and operate simultaneously with other radios in host system; additional testing and equipment authorization may be required to operating simultaneously with other radios.

### **11.2 FCC Radiation Exposure Statement**

This equipment complies with FCC radiation exposure limits set forth for an uncontrolled environment. This equipment should be installed and operated with minimum distance 20cm between the radiator & your body.

### **11.3 FLC-BTM403 Label Instructions**

The FLC-BTM403 module is designed to comply with the FCC statements.



The packaging of host system that uses BTM403 should display a label indicating the information as follows:

Contains FCC ID: P4IBTM403

CE2200

Model: FLC-BTM403IQ2A

(Series models: FLC-BTM403IQ2B/ FLC-BTM403IQ2C/  
FLC-BTM403VQ2A/ FLC-BTM403VQ2B/FLC-BTM403VQ2C)

QDID:

Any similar wording that expresses the same meaning may also be used.

### 11.4 FLC-BTM403 Antenna Statement

**Note:** In this section, “A”, “B” and “C” in “BTM403A”, “BTM403B” and “BTM403C” refer to Product Revision. Please see Section 10.2.1 for reference.

#### 11.4.1 BTM403A and BTM403C

Antenna specifications of BTM403A and BTM403C are listed in the following table:

Part Number	Frequency Range (MHz)	Peak Gain (XZ-V)	Average Gain (XZ-V)	VSWR	Impedance
AT3216 -B2R7HAA_	2400 ~ 2500	0.5 dBi typ.	-0.5 dBi typ.	2 max.	50 Ω

Table 18: Antenna Specifications

Operating Temperature Range: -40 ~ +85 °C

Storage Temperature Range: -40 ~ +85 °C

Power Capacity: 3W max.



The following figure shows the Radiation Patterns of the antenna in BTM403A and BTM403C.

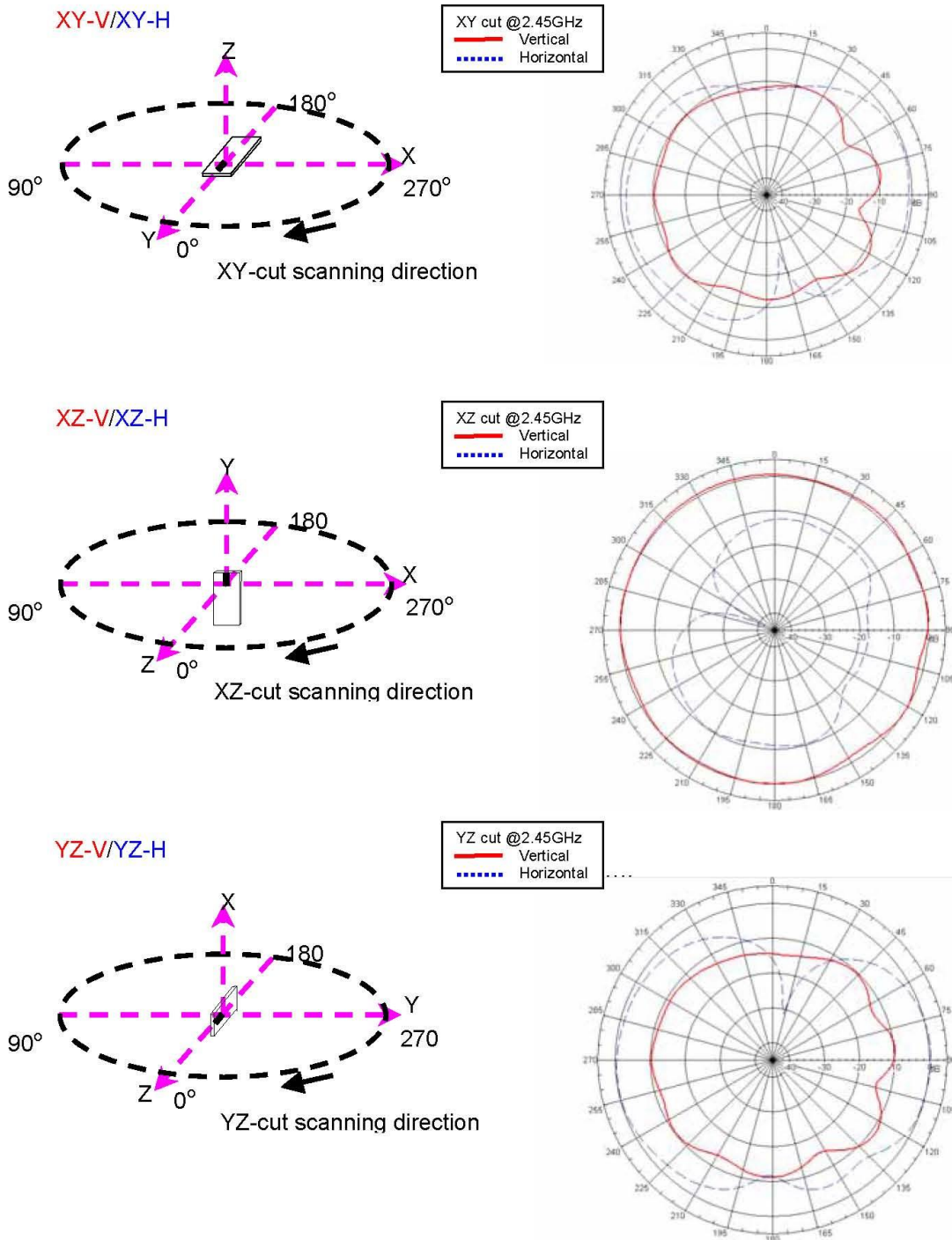

Figure 24: Radiation Patterns of Antenna



### 11.4.2 BTM403B

There is no built-in antenna in BTM403B. BTM403B is integrated with a UFL connector to make it simple for designers to add an external antenna into the module. In order to make the product compliant with the FCC standard, the applicable antennas which designers choose should be similar to the antenna in BTM403A and BTM403C in specifications and radiation patterns. And the gain should be less than the peak gain of the antenna in BTM403A and BTM403C. If designers choose a different antenna, additional testing and equipment authorization are needed to ensure the compliance with FCC statement.