Ultra Mobile PC User's Guide

Model: UM650UV1

First Edition: January 2007

NOTICE

Specifications and information found in this guide are subject to change **without** notice. Any changes therefore will be incorporated in future editions. The manufacturer assumes **no** responsibility for errors or omissions in this document.

TRADEMARKS

Windows™ is the trademark of *Microsoft Corporation*.

Bluetooth® is the trademark owned by its proprietor.

Other trademarks are properties of their respective owners.

Standards

The following standards are adopted throughout this guide:

- Notebook in **boldface** (with or without capitalization) refers to the notebook computer that you have purchased.

- **Boldface** type is also used to highlight **important information** in this document.

- Whenever extra caution is called for, the information will be boxed in a dark frame preceded by "**Note:**" or "**Warning:**"

This page is left blank intentionally.

CONTENTS

CHAPTER 1 BEFORE YOU BEGIN 1-1

- 1.1 CHECKING WHAT YOU RECEIVED 1-1
- 1.2 EXAMINING YOUR COMPUTER..... 1-2
- 1.3 THE FIVE SYSTEM LEDS 1-8
- 1.4 THE THREE CONTROL SWITCHES..... 1-9
- 1.5 THE SIX SYSTEM BUTTONS 1-10
- 1.6 THE FOUR COMMUNICATION BUTTONS 1-11
- 1.7 ATTENTION ON MEDIA CARD SLOT 1-13
- 1.8 TOUCH SCREEN CALIBRATION..... 1-14
- 1.9 OPERATING TEMPERATURE 1-14

CHAPTER 2 BATTERY 2-1

- 2.1 BATTERY PACK 2-1
- 2.2 RECHARGING THE BATTERY PACK..... 2-1
- 2.3 QUESTIONS AND ANSWERS 2-2
- 2.4 BATTERY MAINTENANCE 2-3
- 2.5 POWER CONSUMPTION..... 2-3
- 2.6 REDUCING POWER CONSUMPTION..... 2-4
- 2.7 REMOVING THE BATTERY PACK..... 2-4
- 2.8 CONNECTING SYSTEM TO AC ADAPTER 2-5

CHAPTER 3 THE DOCKING STATION (OPTIONAL) 3-1

- 3.1 DIFFERENT VIEWS OF THE DOCKING STATION..... 3-1
- 3.2 MOUNTING THE DETACHABLE STAND..... 3-5
- 3.3 MOUNTING THE SYSTEM UNIT 3-6
- 3.4 THE STYLUS PEN..... 3-7

CHAPTER 4 THE BAY MODULE CONNECTOR..... 4-1

- 4.1 REMOVING THE FLIP STAND 4-2
- 4.2 THE BAY MODULES..... 4-3

4.3 INSTALLING THE BAY MODULE4-4

4.4 THE GPS MODULE ANTENNA4-5

4.5 THE TV TUNER MODULE ANTENNA4-6

APPENDIX A- AGENCY REGULATORY NOTICES A-1

Chapter 1 Before You Begin

Please read this section before you start using your **Ultra Mobile PC**.

1.1 Checking What You Received

Your **Ultra Mobile PC** package should contain the following items:



- **The Ultra Mobile PC.**
- AC Adapter.
- AC Power Cord.
- CD Disc (Including Drivers and User's Guide).
- Battery Pack.
- TV Module with Antenna (Option).
- GPS Module with Antenna (Option).
- Docking Station (Option).

Note: You should keep the original factory carton and packing materials in case you need to ship the unit back for servicing.

1.2 Examining Your Computer

Before you start using your computer, you need to get acquainted with its main features and interfaces:

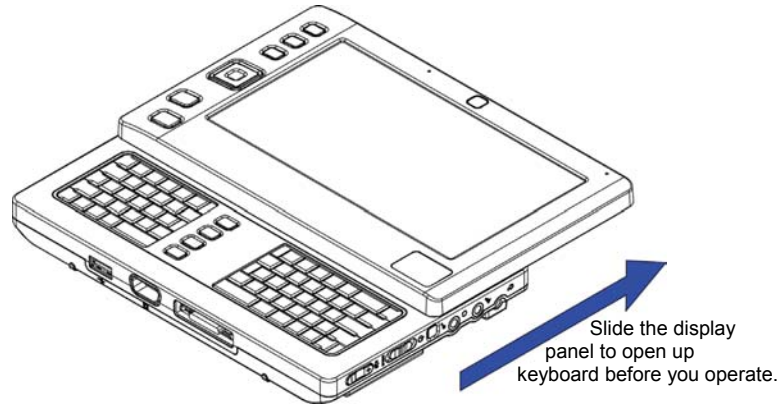

Panoramic View

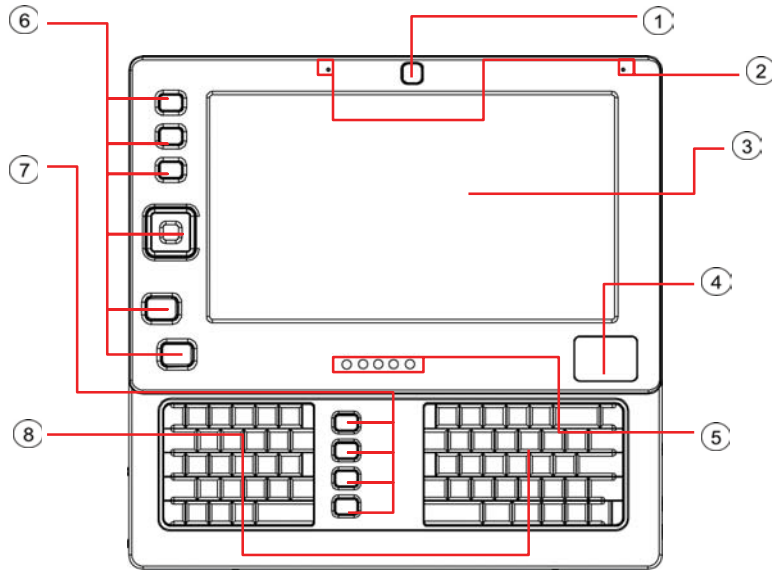

Top View

① Web Cam	⑤ Five System LEDs
② Two Internal Microphones	⑥ Six System Buttons
③ LCD Screen	⑦ Four Communication Buttons
④ Touch Pad	⑧ Keyboard

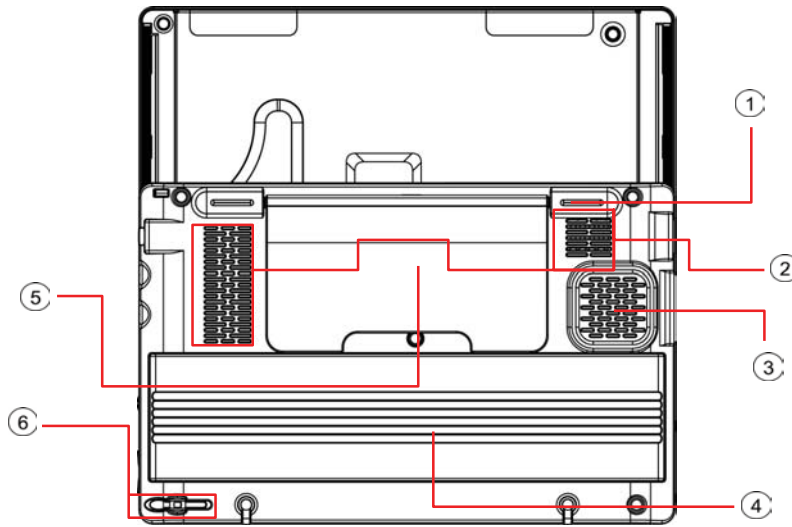

Bottom View

① Support Foot (also serves to lock and to disassemble the Flip Stand)	④ Battery Pack
② Ventilation Holes	⑤ Flip Stand
③ Speaker	⑥ Stylus Slot

Note: The stylus pen together with the system touch-screen LCD display provides you a touch-screen operation by emulating the industry standard mouse left click. You are advised to keep the stylus pen in the stylus slot when not in use.

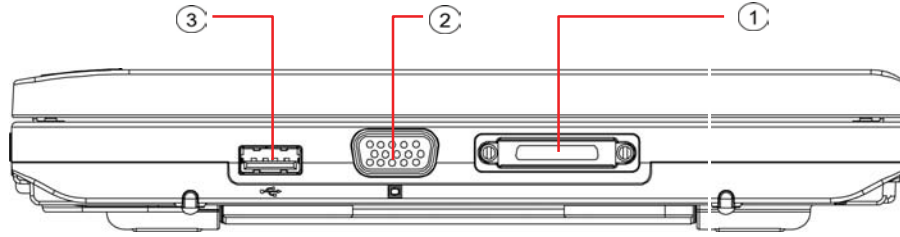

Front View

① Connector for Docking Station	③ USB Connector
② VGA Connector	

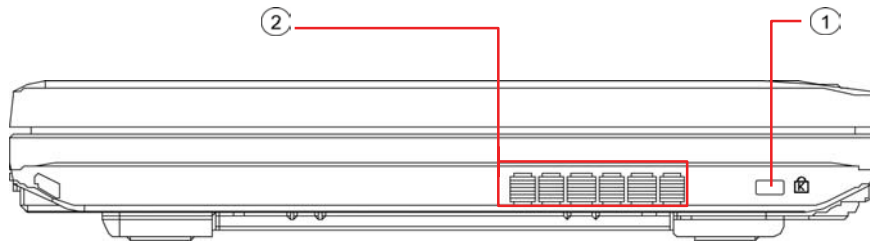

Rear View

① Kensington Lock	② Ventilation Holes
-------------------	---------------------

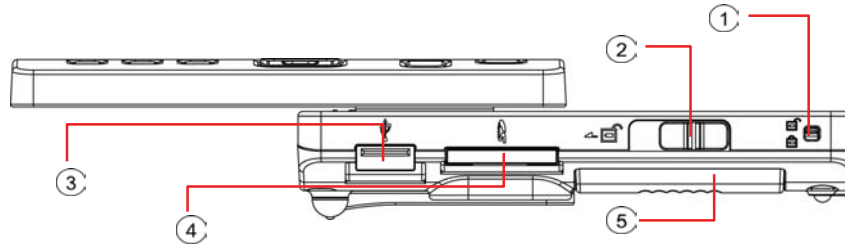

Left View

① Battery Lock	④ Media Card Slot (SD/ SD-IO/ MMC)
② Battery Latch	⑤ Battery Pack
③ USB Connector	

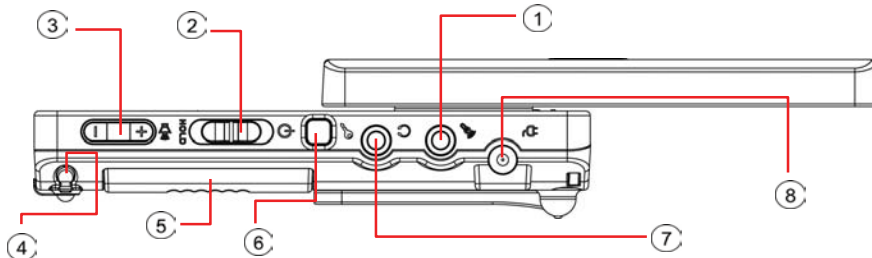

Right View

① Microphone Jack	⑤ Battery Pack
② Power/Hold Switch	⑥ The SAS (Alt+Ctrl+Del) Switch
③ Volume (Increase/Decrease) Switch	⑦ Headphone Jack
④ Stylus Slot	⑧ DC-In Jack

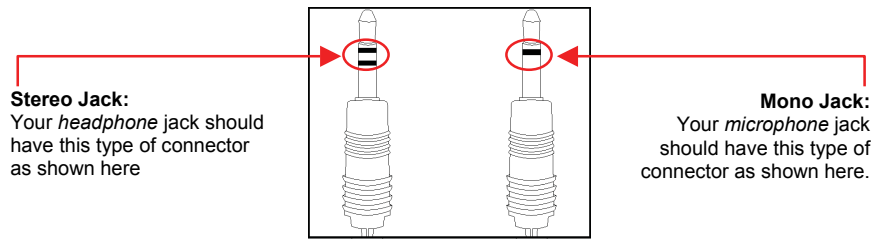

Two Types of Audio Jack

1.3 The Five System LEDs



The Bluetooth® LED

This LED would be lit when the **Bluetooth®** is powered on. For details on how to power on and power off the **Bluetooth**, please refer to *Chapter 1.6*.



The Wireless LAN LED

This LED would be lit when the **Wireless LAN** is powered on. For details on how to power on and power off the **Wireless LAN**, please refer to *Chapter 1.6*.



The HDD Access LED

This LED would be lit when system is accessing the HDD drive.



The Battery Pack LED

Below is how the LED would behave in different situations:

On	Battery pack is being recharged: fast-charge or pre-charge.
Off	Battery pack is not under recharge.
Blinking	Battery pack is consuming down to 10% level.



The Power On LED

Below is how the LED would behave in different situations:

Off	System is powered off, or in Hibernate mode.
On	System is in full operation.
Blinking	System is in Standby mode.

Note: The Five System LEDs are located near the bottom of display panel. For exact location, please refer to the **Top View** diagram in *Chapter 1.2*.

For more details on **Standby** and **Hibernate**, please refer to **Power Options** in the **Control Panel** of your Microsoft Windows™ operating system.

1.4 The Three Control Switches



The SAS (Alt+Ctrl+Del) Switch

Press this switch to emulate Windows' "Alt", "Ctrl" and "Del" buttons pressed simultaneously.



The Power/Hold Switch

Slide this switch to the right (⏻) to emulate standard power button of a personal computer. The power button is programmable by user. For details on how to program the power button, please refer to the **Power Options** of **Control Panel** in **Windows™** System.

Slide this switch to the left (**HOLD**) to temporarily suspend inputs from the **keyboard, touch pad, six system buttons** on the left side of the LCD screen, and the **four communication buttons** in between the left/right keyboard. Manually slide this switch back to the middle to resume functions of the above input devices. The purpose of this switch is to prevent mis-triggering of these input devices while the system unit is idle when it is powered up. For exact locations of these input devices, please refer to **Top View** diagram in *Chapter 1.2*.



The Volume Switch

Click this switch to the right (+) to increase audio volume. Click this switch to the left (-) to decrease audio volume.

Note: The **Three Control Switches** is located on the right side of system unit. For exact location, please refer to the **Right View** diagram in *Chapter 1.2*.

1.5 The Six System Buttons

**The Mobility Center Button**

Press this button to enter into the menu of **Windows Mobility Center** in Windows Vista™ operating system.

**The Zoom-In Button**

Press this button to activate the zoom-in function whereby portion of the display screen near the mouse cursor would be enlarged and displayed near the topside of the display screen.

**The Enter Button**

Press this button to emulate the function of “Enter”.

**The Scroll Button**

Press this button to emulate the functions of these four “←”, “→”, “↑”, and “↓” keycaps.

**The Left Mouse Button**

Press this button to emulate the left mouse function.

**The Right Mouse Button**

Press this button to emulate the right mouse function.

Note: The **Six System Buttons** are located on the left side of the LCD display. For exact location, please refer to the **Top View** diagram in *Chapter 1.2*.

1.6 The Four Communication Buttons



The Bluetooth Button

Press this button to power on and power off the **Bluetooth®** module. Powering on the **Bluetooth®** by pressing this button does not automatically activate the **Bluetooth®** function. After powering on, you need to activate the **Bluetooth®** function through Windows™. The main purpose of this button is to provide you a quick way to turn off the power of **Bluetooth®** when entering venues like airplanes, airports, and hospitals where the usage of **Bluetooth®** is prohibited or not advisable.



The Wireless LAN Button

Press this button to power on and power off the **Wireless LAN** module. Powering on the **Wireless LAN** by pressing this button does not automatically activate the **Wireless LAN** function. After powering on, you need to activate the **Wireless LAN** function through Windows™. The main purpose of this button is to provide you a quick way to turn off the power of **Wireless LAN** when entering venues like airplanes, airports, and hospitals where the usage of **Wireless LAN** is prohibited or not advisable.



The Web Cam Button

Press this button to power on and power off the **Web Cam** module. After powering on the **Web Cam**, you need to activate its function through Windows™.



The BAY Button

Press this button to power on and power off the **GPS Module** or **TV Tuner Module**. Powering on the **GPS Module** or **TV Tuner Module** by pressing this button does not automatically activate the respective functions. After powering on, you need to activate the function through Windows™. This button would work only when the system is powered on, and either one of the **GPS** or **TV Tuner Module** is connected into the system unit. **Note: GPS and TV Tuner Modules** are optional and need to be purchased separately. For details on how to connect these modules to the system unit, please refer to *Chapter 4*.

Note: The proper way to activate the above devices and modules is as below:
1) Press the above buttons to power on the devices, and modules.
2) Activate the respective application programs in Windows™.

The effective range of the system **Bluetooth®** is 10 meters.

Note: The **Four Communication Buttons** are located between the left/right keyboards. For exact location, please refer to the **Top View** diagram in *Chapter 1.2*.

1.7 Attention On Media Card Slot

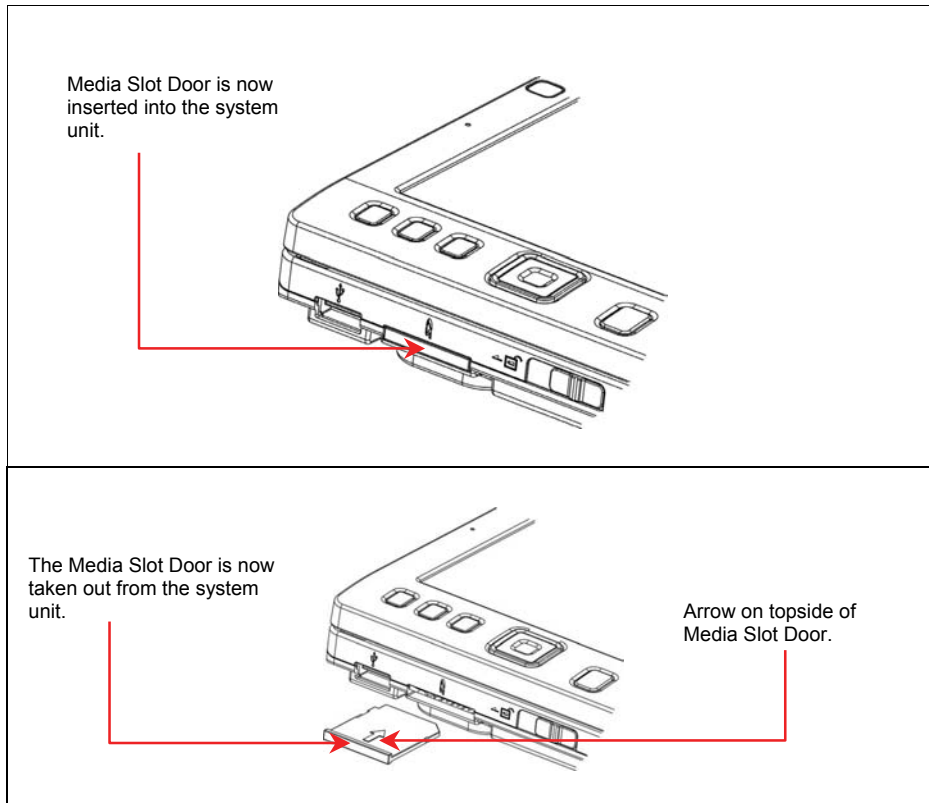

Please observe below safety measures:

- When no card (SD/SD-IO/ MMC cards) is inserted into the media slot, make sure this slot is covered by the “media slot door” as supplied together with this **Ultra Mobile PC**. The purpose of this “media slot door” is to prevent foreign matters from entering into the system unit through this slot, when no card is inserted. When inserting this “media slot door”, please make sure the arrow is on the topside as shown above. Inserting this door upside down may cause damage to your **Ultra Mobile PC**.

1.8 Touch Screen Calibration

The stylus pen together with the system touch-screen LCD display provides you a touch-screen operation by emulating the industry standard mouse left click. Below are the two conditions that you need to calibrate your touch-screen.

- The first time Windows is installed and boot up. The active cursor is shifted; not exactly the same position where the stylus pen tip is tapped.
- Periodically when you find the active cursor is shifted away from the screen position where the stylus pen tip is tapped.

To calibrate the touch-screen, go into **Tablet PC Setting** of **Control Panel** of **Windows™ VISTA®**. In the **Tablet PC Setting** screen, select **General** and then **Calibrate**. Then follow instruction to complete calibration.

Note: You need to set screen display resolution to 800x600 before proceeding with the calibration.

1.9 Operating Temperature

Operating Temperature : 10°C to 35°C.

Chapter 2 Battery

2.1 Battery Pack ---

Your **Ultra Mobile PC** is equipped with a high-energy rechargeable **Lithium Ion (Li-Ion)** battery pack. Battery life will vary depending on the product configuration, product model, applications loaded on the product, power management settings of the product, and the product features used by the customer. As with all batteries, the maximum capacity of this battery will decrease with time and usage.

2.2 Recharging The Battery Pack ---

Your **Ultra Mobile PC** supports both on-line and off-line recharge. Follow the procedure below to recharge battery:

- Make sure the battery pack is installed in the **Ultra Mobile PC**.
- Connect the AC adapter to the **Ultra Mobile PC** and to an electrical outlet.

When a battery pack is being recharged, its battery LED (located at the bottom of LCD display) would be lit. For details on the LEDs, please refer to *Chapter 1.3*. When the **Ultra Mobile PC** is OFF, a depleted Li-Ion battery will take three hours to recharge.

2.3 Questions And Answers

Q: I can feel a mild heat next to the battery pack. Is it normal?

A: The battery will generate heat during recharging and discharging. There is a protection circuit inside the **Ultra Mobile PC** to prevent overheating. User needs not to worry.

Q: My battery operation time is not as long as it should be. Why?

A: The battery is heat sensitive and can only be charged to its maximum if the battery and its environmental temperature remain within 15-25°C (59-77°F). The more the temperature deviates from this range during recharging, the less chance there is for the battery to be fully charged. In order to recharge the pack to its full capacity, users are requested to cool down the unit by unplugging the AC Adapter. Wait until it is cooled down. Then plug in the AC Adapter to start recharging again.

Q: I did not use my spare battery for a few days. Even though it was fully recharged, there wasn't as much power left as a newly charged one. Why?

A: The batteries will self-discharge (1% per day for Li-Ion) when they are not being recharged. To make sure a battery pack is fully charged, recharge before use. Always keep the battery inside the **Ultra Mobile PC** and have the AC adapter connected whenever possible.

Q: I did not use my spare battery for months. I have problem in recharging it.

A: If you happen to leave your battery pack to go through an extended period of self-discharge, say more than three months, the battery voltage level will become too low and needs to be **Pre-Charged** (to bring the battery voltage level high enough) before it automatically (for Li-Ion only) resumes its normal **Fast Charge**. **Pre-Charge** may take 30 minutes. **Fast Charge** usually takes 2~3 hours.

2.4 Battery Maintenance

To maintain the battery pack's maximum capacity, you should occasionally let the **Ultra Mobile PC** deplete its battery power completely before recharging.

To carry out a complete depletion of the battery, disconnect the AC adapter and let your **Ultra Mobile PC** consume the remaining battery power. To speed up the depletion, use the HDD as much as possible. When the battery is empty, wait for the **Ultra Mobile PC** to cool down (especially the battery). The temperature should be within 15-25°C (59-77°F). Then insert the AC adapter to recharge the battery.

2.5 Power Consumption

The **Windows™** operating system has incorporated the latest state-of-the-art **ACPI (Advanced Configuration Power Interface)** power management methodology. In order to fully utilize the power of your battery packs, it would be a good idea for you to spend sometime to acquire a basic understanding of the power management concept from your operating system.

In **Windows™ Operating Systems**, you can go through **Power Options** of the **Control Panel** according to the version of **Windows™ Operating System** the **Ultra Mobile PC** applies. We shall not describe them in details.

2.6 Reducing Power Consumption

Although your **Ultra Mobile PC** (together with the operating system) is capable of power conservation, there are measures you can take to reduce the power consumption:

- Use the AC power whenever possible.
- Try to use the HDD drive to read and write files, instead of using the external USB FDD.
- Disable unused devices, such as Web Cam, WLAN, Bluetooth®, and etc.
- Decrease LCD panel brightness through Windows.

Note: Whenever system is powered on or powered off, make sure the battery pack is installed in the battery pack compartment.

2.7 Removing The Battery Pack

This battery pack can easily be removed and replaced. Make sure that the computer is properly shutdown before changing the battery pack. If you would like to change the battery pack while power is on, make sure this battery pack is not the only electrical source to the system unit. Follow the steps below to remove the battery pack.

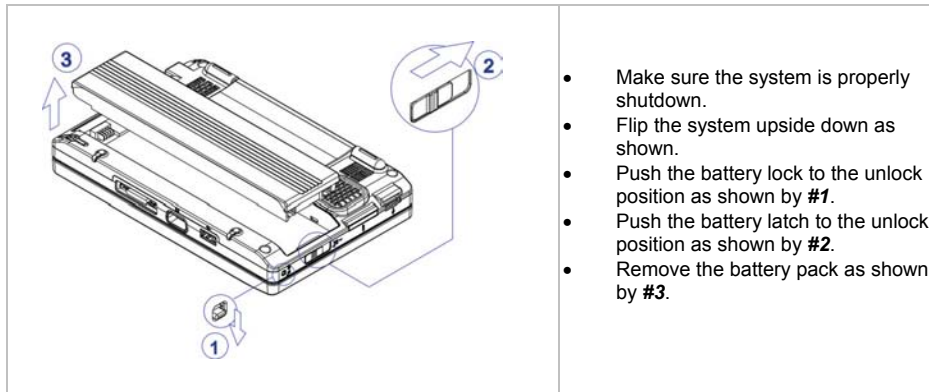

To insert the battery pack, reverse the steps above.

2.8 Connecting System To AC Adapter

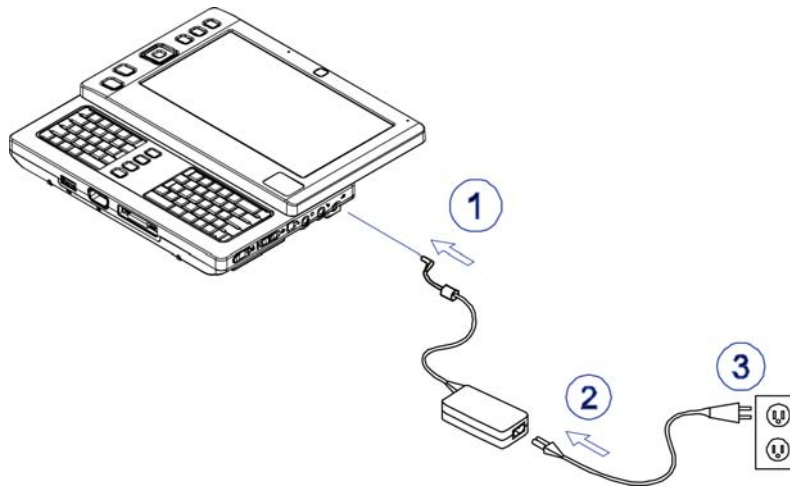

- Connect **AC adapter** to system unit as shown by #1.
- Connect **AC power cord** to **AC adapter** as shown by #2.
- Connect other end of **power cord** to an electrical outlet as shown by #3.

This page is left blank intentionally.

Chapter 3 The Docking Station (Optional)

Depending on model, your **Ultra Mobile Personal Computer** is equipped with an optional **Docking Station**. This **Docking Station** does not support hot plug-and-play with the system unit.

3.1 Different Views Of The Docking Station

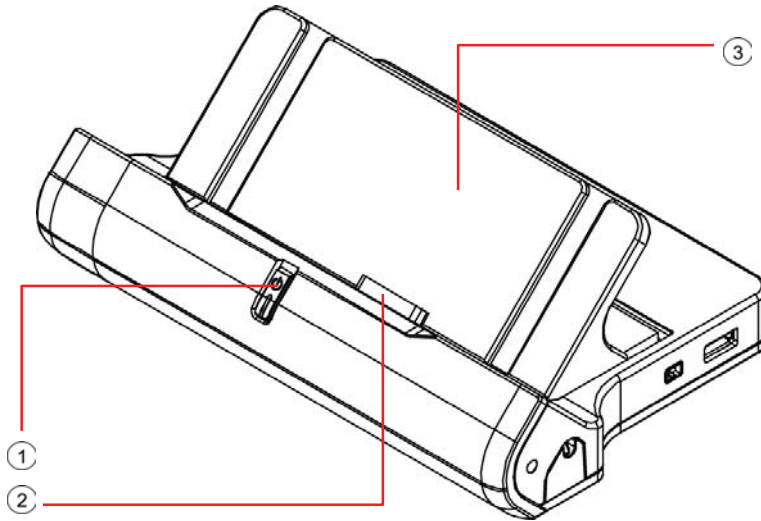

Panoramic View

① Power Button	③ Detachable Stand
② Connector to System Unit	

Note: This **Power Button** has the same function as the **Power Switch** as described in *Chapter 1.4*. For details, please refer to *Chapter 1.4*.

The **Detachable Stand** is shipped not mounted to the main body of the **Docking Station** as shown above. For details on how to mount this **Detachable Stand**, please refer to *Chapter 3.2*.

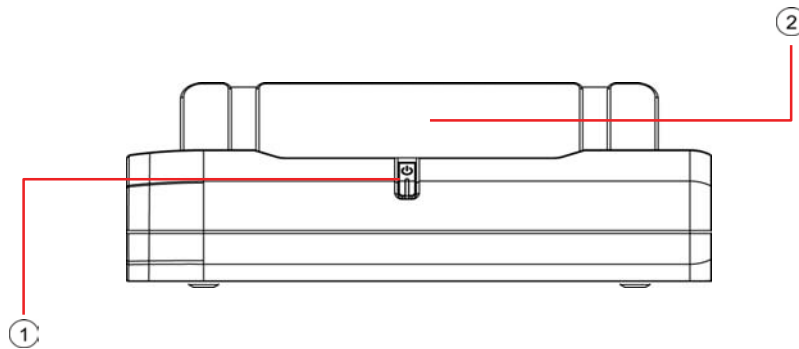

Front View

① Power Button	② Detachable Stand
----------------	--------------------

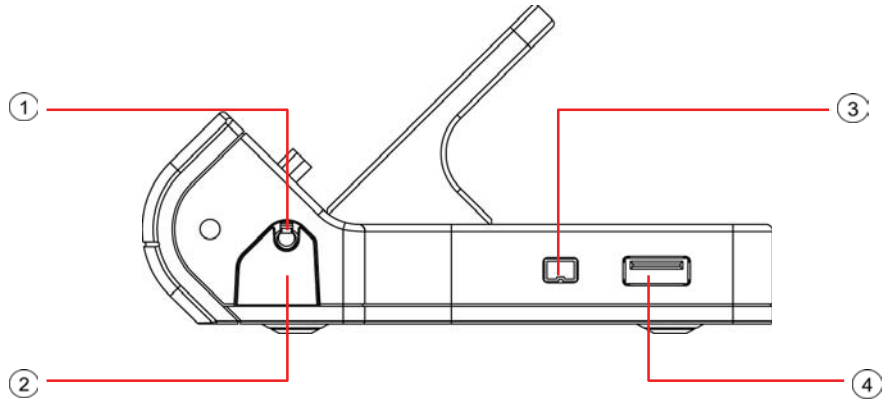

Right View

① Stylus Pen	③ IEEE 1394 Connector
② Stylus Pen Tray (push to eject)	④ USB Connector

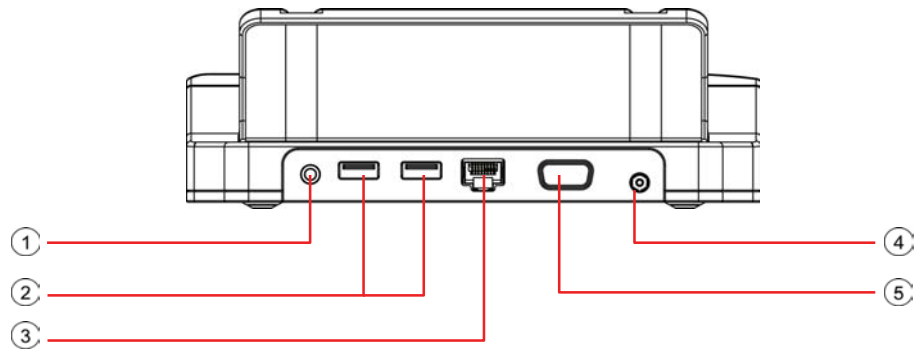

Rear View

① Headphone Jack	④ DC-In Jack
② USB Connectors	⑤ VGA Connector
③ RJ45 LAN Connector	

3.2 Mounting The Detachable Stand

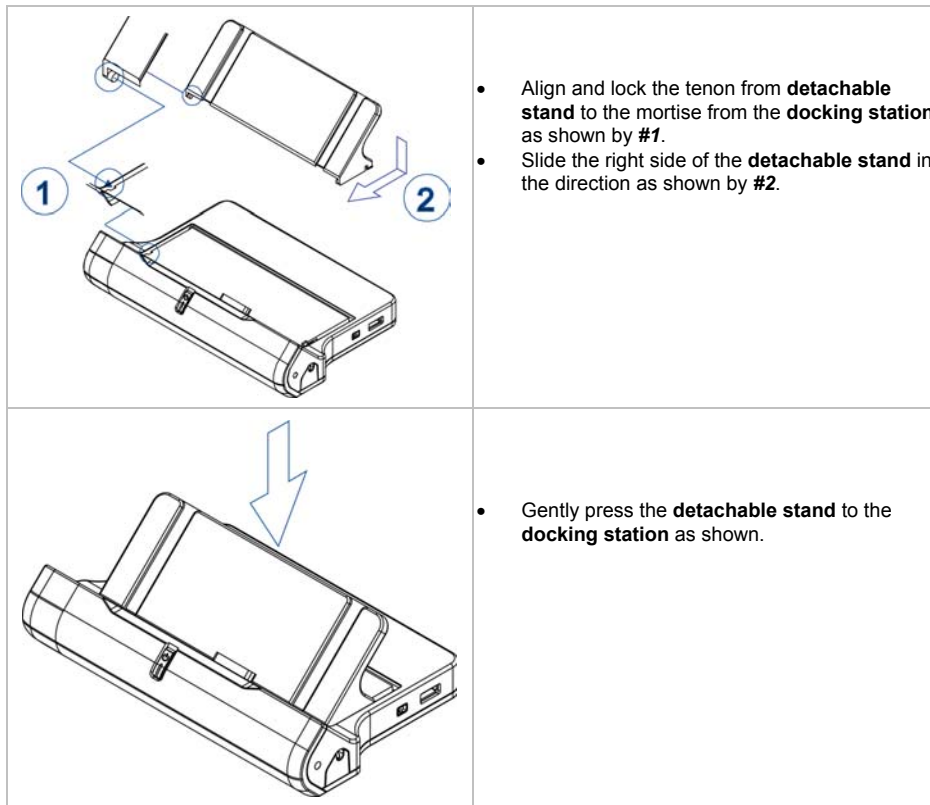

Reverse the above steps to un-mount the **detachable stand**.

3.3 Mounting The System Unit

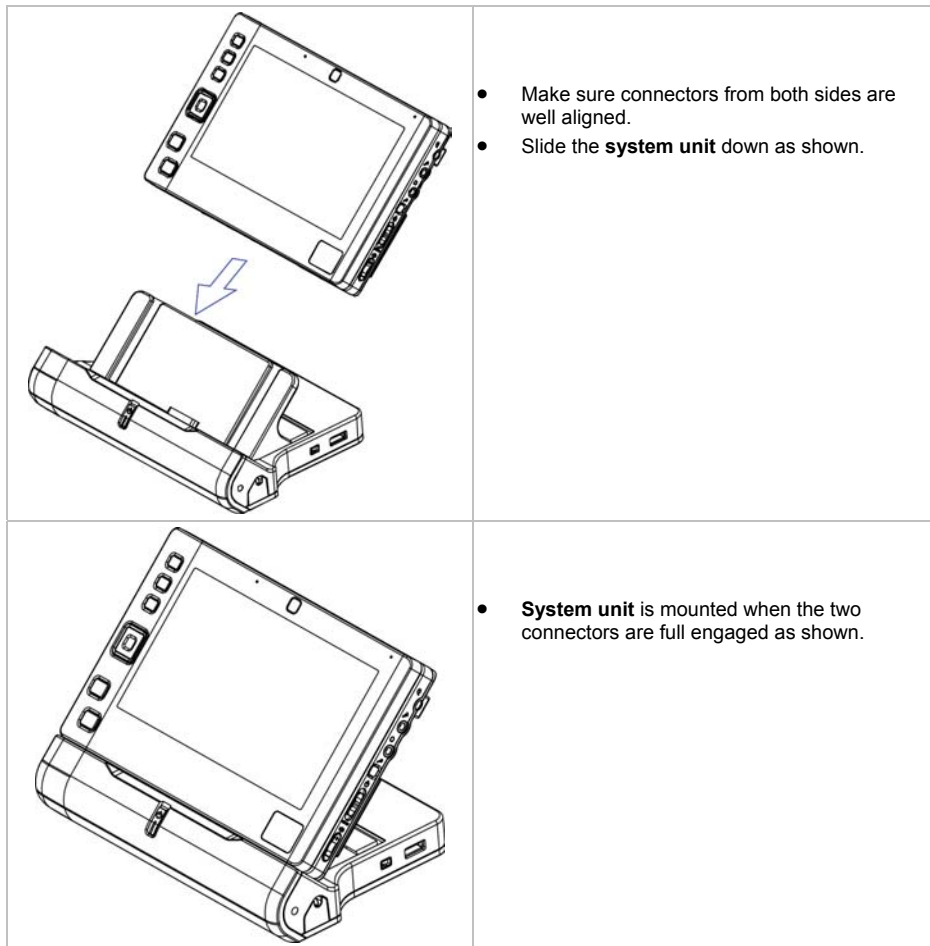

Reverse the above steps to un-mount the **system unit**.

3.4 The Stylus Pen

The stylus pen can be taken out and erected as shown below:

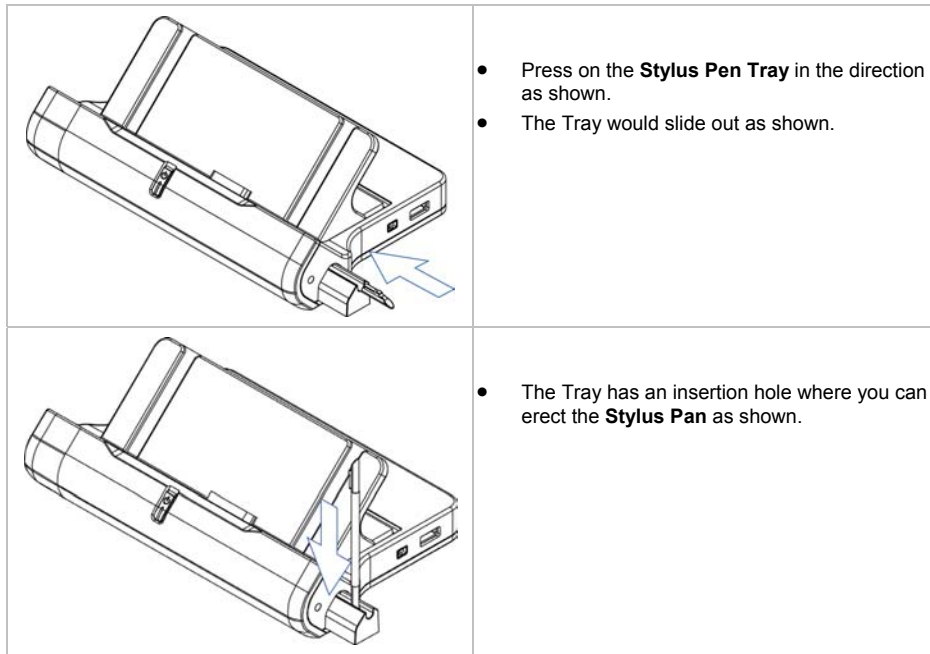

This page is left blank intentionally.

Chapter 4 The BAY Module Connector

This **Ultra Mobile PC** has a **BAY Module Connector** whereby you can either choose to connect it to a **GPS (Global Positioning System) Module**, or a **TV Tuner Module**. Both the **GPS Module** and **TV Tuner Module** are optional and need to be purchased separately. The **BAY Module Connector** is underneath the **flip stand**. Diagram below shows the bottom view of the system unit with the **flip stand** removed.

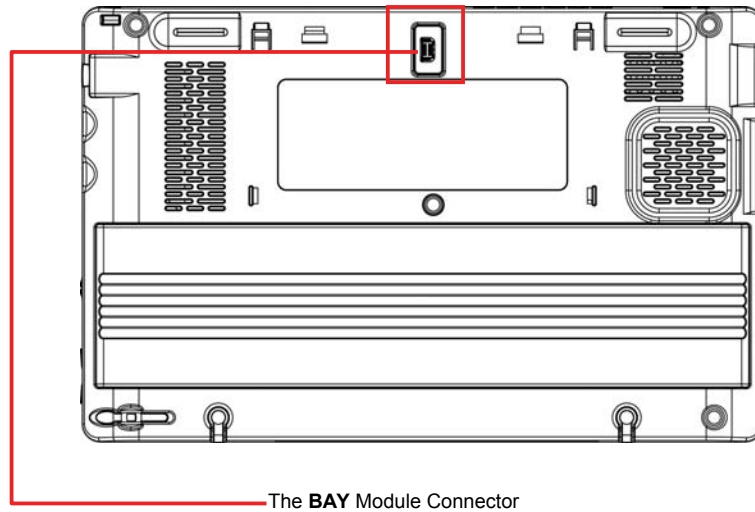

The rest of this chapter describes how the **flip stand** is removed and how the **GPS Module** and **TV Tuner Module** are installed to the system unit.

4.1 Removing The Flip Stand

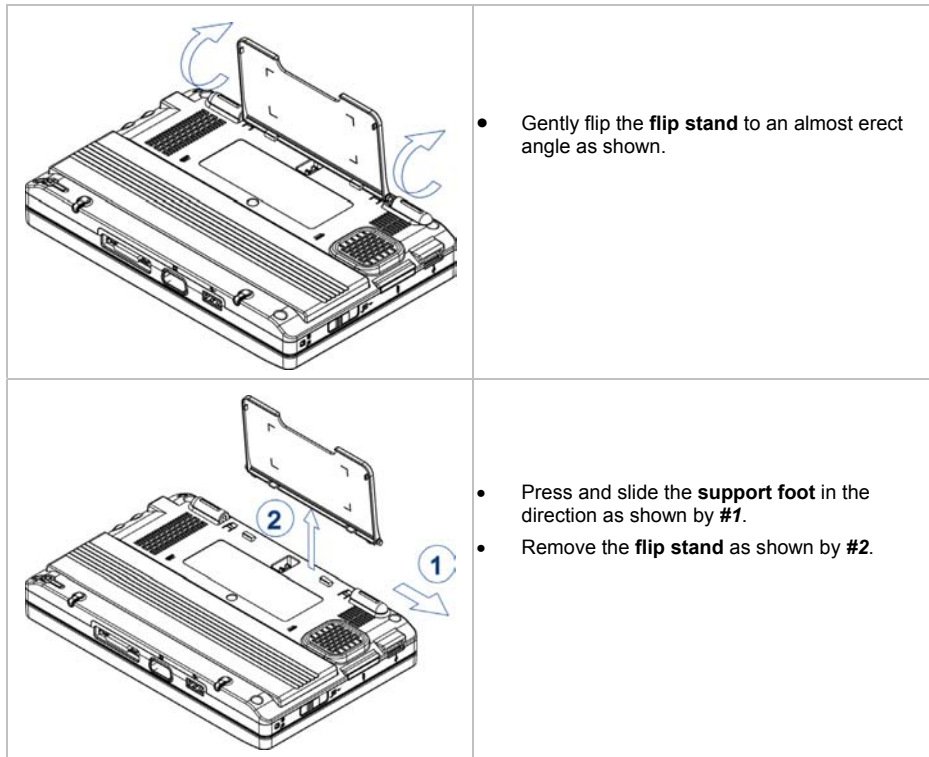

Reverse the steps above to put back the **flip stand**.

4.2 The BAY Modules

Externally, the **GPS Module** and **TV Tuner Module** looked very much the same as shown below.

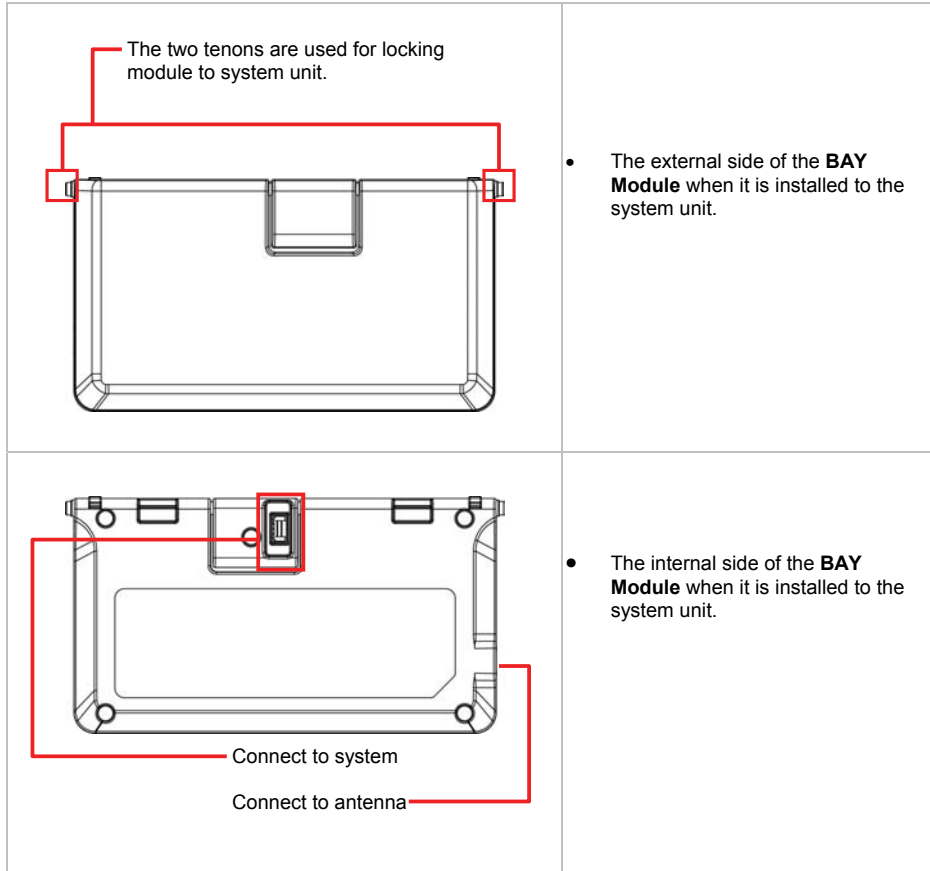

4.3 Installing The BAY Module

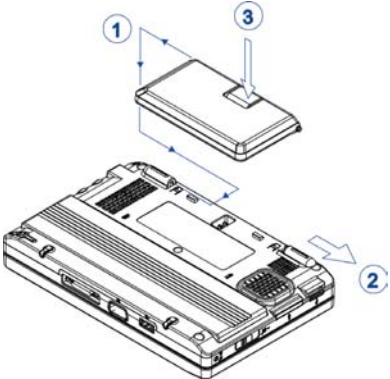
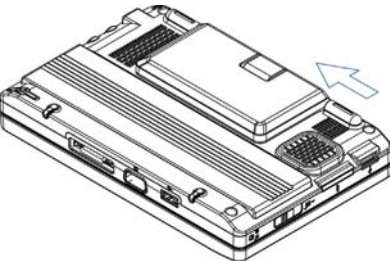
	<ul style="list-style-type: none">• Align and lock the tenon from the module to the mortise from the system unit as shown by #1.• Slide support foot in the direction as shown by #2.• Gently press on the back of the connector to connect module as shown by #3.
	<ul style="list-style-type: none">• The support foot would slide back by itself in the direction as shown. The module is locked to the system unit.

Reverse the above steps to remove the **BAY Module**.

4.4 The GPS Module Antenna

The **GPS Module** has a built-in internal antenna. For better receptions and transmissions, it is better to use its proprietary external antenna as shown below.

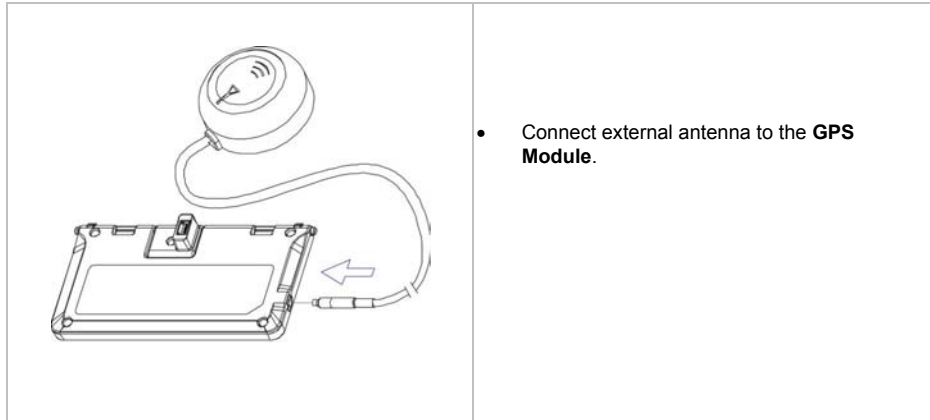

4.5 The TV Tuner Module Antenna

The earlier version of the **TV Tuner Module** is without a built-in internal antenna. Therefore, it is necessary to use its proprietary external antenna as shown below.

The later version of the **TV Tuner Module** is with built-in internal antenna. However for better receptions and transmissions, it is better to use its proprietary external antenna as shown below.

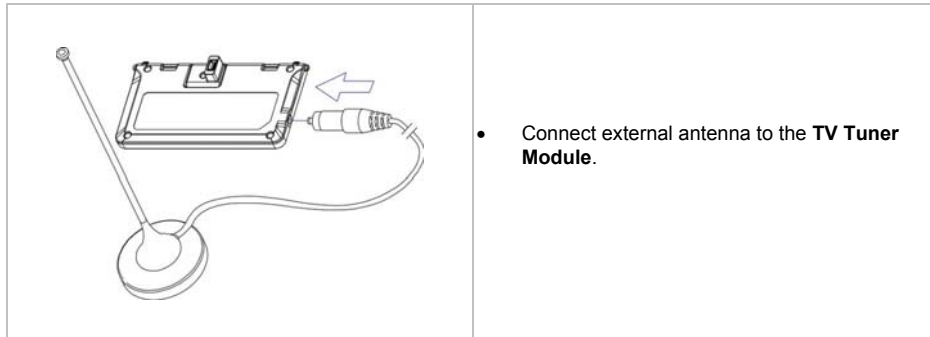

Appendix A- Agency Regulatory Notices

A.1 Safety Instructions



CAUTION: Please read these safety instructions carefully.



CAUTION: Please keep this User's Manual for future reference.



CAUTION: Please disconnect this equipment from AC outlet before cleaning. DO NOT use liquid or sprayed detergent for cleaning. Use a clean moistened cloth.



CAUTION: The wall socket used should be positioned near the equipment and should be easily accessible.



CAUTION: Please keep this equipment free from humidity.



CAUTION: Place the equipment on a reliable surface at all times. A drop or fall can cause severe damage.



WARNING: The openings of the enclosure are for air ventilation and are meant to protect the equipment from overheating. DO NOT COVER THE VENTILATION OPENINGS.



CAUTION: Verify the voltage of the power source before connecting the unit to any power outlet.



WARNING: DO NOT step on or place anything over the power cord.



CAUTION: All cautions and warnings on the equipment should be noted.



WARNING: If the equipment is not used for a long period of time, disconnect the equipment from the power source to avoid damage from power spikes.



WARNING: NEVER pour any liquid into any openings; a fire or electrical shock is possible.



WARNING: For safety reasons, other than pre-designated ports, doors, and the equipment should be opened only through qualified service personnel.



CAUTION: If one of the following situations should arise, the equipment should be checked by an authorized technician:

- a. The power cord or plug is damaged.
 - b. Liquid has penetrated into the equipment.
 - c. The equipment has been exposed to excessive moisture.
 - d. The equipment does not work well, or you fail to get it to work according to user's manual.
 - e. The equipment has been dropped or damaged.
 - f. The equipment has obvious signs of breakage.
-
-



CAUTION: DO NOT LEAVE THE EQUIPMENT IN TEMPERATURES BELOW -20°C(-4°F) OR ABOVE 60°C(140°F). IT MAY CAUSE DAMAGE TO THE EQUIPMENT.



WARNING: Never install modem/telephone wiring during a lightning storm.



WARNING: Never install modem/telephone jacks in wet locations unless the jack is specially designed for wet locations.



WARNING: Never touch un-insulated modem/telephone wires or terminals unless the modem/telephone line has been disconnected at the network interface.



CAUTION: Use caution when installing or modifying modem/telephone lines.



WARNING: Avoid using a modem/telephone (other than a cordless type) during an electrical storm. There may be a remote risk of electric shock from lightning.



WARNING: This computer contains an internal lithium battery-powered real-time circuit. There is a risk of explosion and injury if the battery is incorrectly replaced or handled. Do not attempt to recharge, disassemble, immerse in water, or dispose of it in fire. Replacement should be done through your notebook dealer.



WARNING: Danger of explosion if battery is incorrectly replaced. Replace only with the same or equivalent type recommended by the manufacturer. Dispose of used batteries according to the manufacturer's instructions.
Explosionsgefahr bei unsachgemäßen Austausch der Batterie. Ersatz nur durch denselben oder einem vom Hersteller empfohlenem ähnlichen Typ. Entsorgung gebrauchter Batterien nach Angaben des Herstellers.



WARNING: Your UMPC contains a Ni-MH or Li-Ion battery pack. There is a risk of fire and chemical burn if the battery pack is handled improperly. Do not disassemble, crush, puncture, short external contact, dispose of in water or fire, or expose it to temperature higher than 60°C.



WARNING: Handle the battery pack very carefully. Avoid touching the metal leads on the connector of the battery case.



CAUTION: Use only approved AC Adapter with your notebook. Using the wrong type of AC Adapter may cause serious damage to your notebook.



CAUTION: The AC Adapter can accept a line voltage ranging from 100V to 240V and is compatible with most international power sources. If you are unsure whether your power source is compatible, please contact the local dealer for assistance.



CAUTION: For Continued Protection Against Risk of Fire, Replace Only with same Type and Rating of Fuse.



CAUTION: If the computer is not sold to German area, please use only the local recognized power supply cords that are recommended by the manufacturer.



WARNING: Don't expose your **UMPC** to excessive heat or coldness (frost).
Don't drop, spill fluids or open the exterior of the case. This can damage the
UMPC and void the warranty.

A.2 Agency Notice

Federal Communications Commission Notice

This equipment has been tested and found to comply with the limits for a Class B digital device, pursuant to part 15 of the FCC Rules. These limits are designed to provide reasonable protection against harmful interference in a residential installation. This equipment generates, uses and can radiate radio frequency energy and, if not installed and used in accordance with the instructions, may cause harmful interference to radio communications.

However, there is no guarantee that interference will not occur in a particular installation. If this equipment does cause harmful interference to radio or television reception, which can be determined by turning the equipment off and on, the user is encouraged to try to correct the interference by one or more of the following measures:

- Reorient or relocate the receiving antenna.
- Increase the separation between the equipment and receiver.
- Connect the equipment into an outlet on a circuit different from that to which the receiver is connected.
- Consult the dealer or an experienced radio or television technician for help.

Modifications

The FCC requires the user to be notified that any changes or modifications made to this device that are not expressly approved by the manufacturer responsible for compliance may void the user's authority to operate the equipment.

Cables

Connections to this device must be made with shielded cables with metallic RFI/EMI connector hoods to maintain compliance with FCC Rules and Regulations.

This device complies with part 15 of the FCC Rules. Operation is subject to the following two conditions:

- (1) This device may not cause harmful interference, and
- (2) This device must accept any interference received, including interference that may cause undesired operation.

FCC RF Radiation Exposure Statement

- This transmitter must not be co-located or operating in conjunction with any other antenna or transmitter.

USA and Canada Safety Requirements And Notices

The FCC with its action in ET Docket 93-62 has adopted a safety standard for human exposure to radio frequency (RF) electromagnetic energy emitted by FCC certified equipment. The Intel PRO/Wireless LAN MiniPCI Adapter products meet the Human Exposure limits found in OET Bulletin 65, 2001, and ANSI/IEEE C95.1, 1992. Proper operation of this radio according to the instructions found in this manual will result in exposure substantially below the FCC's recommended limits.

The following safety precautions should be observed:

- Do not touch or move antenna while the unit is transmitting or receiving.
- Do not hold any component containing the radio such that the antenna is very close or touching any exposed parts of the body, especially the face or eyes, while transmitting.
- Do not operate the radio or attempt to transmit data unless the antenna is connected; if not, the radio may be damaged.

Use in specific environments:

- The use of wireless devices in hazardous locations is limited by the constraints posed by the safety directors of such environments.
- The use of wireless devices on airplanes is governed by the Federal Aviation Administration (FAA).
- The use of wireless devices in hospitals is restricted to the limits set forth by each hospital.

Explosive Device Proximity Warning

Warning: Do not operate a portable transmitter (such as a wireless network device) near unshielded blasting caps or in an explosive environment unless the device has been modified to be qualified for such use.

Use On Aircraft Caution

Caution: Regulations of the FCC and FAA prohibit airborne operation of radio-frequency wireless devices because their signals could interfere with critical aircraft instruments.

Canadian Notice

This Class B digital apparatus meets all requirements of the Canadian Interference-Causing Equipment Regulations.

Avis Canadien

Cet appareil numérique de la classe B respecte toutes les exigences du Règlement sur le matériel brouilleur du Canada.

Canada Radio Frequency Interference Requirements

This Class B digital apparatus complies with Canadian ICES-003, Issue 2, and RSS-210, Issue 4 (Dec. 2000).

“To prevent radio interference to the licensed service, this device is intended to be operated indoors and away from windows to provide maximum shielding. Equipment (or its transmit antenna) that is installed outdoors is subject to licensing.”

Cet appareil numérique de la classe B est conforme à la norme NMB-003, No. 2, et CNR-210, No. 4 (Dec. 2000).

“Pour empêcher que cet appareil cause du brouillage au service faisant l’objet d’une licence, il doit être utilisé à l’intérieur et devrait être placé loin des fenêtres afin de fournir un écran de blindage maximal. Si le matériel (ou son antenne d’émission) est installé à l’extérieur, il doit faire l’objet d’une licence.”

European Union Notice

Product with the CE Marking comply with the EMC Directive (89/336/EEC) and the Low Voltage Directive (73/23/EEC) issued by the Commission of the European Community and if this product has telecommunication functionality, the R&TTE Directive (1999/5/EC).

Compliance with these directives implies conformity to the following European Norms (in parentheses are the equivalent international standards and regulations):

- EN55022 (CISPR 22)— Electromagnetic Interference
- EN55024 (IEC61000-4-2,3,4,5,6,8,11)— Electromagnetic Immunity
- EN61000-3-2— (IEC61000-3-2)-Power Line Harmonics
- EN61000-3-3— (IEC61000-3-3)-Power Line Flicker
- EN60950 (IEC60950) — Product Safety

For devices with built-in wireless equipment, the following additional standards apply:

- ETSI301489-17: General Emissions for Radio Equipment
- EN60950: Safety
- ETSI300328-2: Technical Requirements for Radio Equipment

CE Caution: Due to the fact that the frequencies used by 802.11b/802.11g wireless LAN devices may not yet be harmonized in all countries, 802.11b/802.11g products are designed for use only in specific countries or regions, and are not allowed to be operated in countries or regions other than those of designated use. As a user of these products, you are responsible for ensuring that the products are used only in the countries or regions for which they were intended and for verifying that they are configured with the correct selection of frequency and channel for the country or region of use. And deviation from permissible settings and restrictions in the country or region of use could be an infringement of local law and may be punished as such.

The wireless LAN device can currently be used indoors only in the following departments of mainland France.

01	Ain	36	Indre	69	Rhône
02	Aisne	37	Indre et Loire	70	Haute Saône
03	Allier	39	Jura	71	Saône et Loire
05	Hautes Alpes	41	Loir et Cher	72	Sarthe
08	Ardennes	42	Loire	75	Paris
09	Ariège	45	Loiret	77	Seine et Marne
10	Aube	50	Manche	78	Yvelines
11	Aude	54	Meurthe et Moselle	79	Deux Sèvres
12	Aveyron	55	Meuse	82	Tarn et Garonne
16	Charente	57	Moselle	84	Vaucluse
19	Corrèze	58	Nièvre	86	Vienne
2A	Corse Sud	59	Nord	88	Vosges
2B	Haute Corse	60	Oise	89	Yonne
21	Côte d'Or	61	Orne	90	Territoire de Belfort
24	Dordogne	63	Puy du Dôme	91	Essonne
25	Doubs	64	Pyrénées Atlantique	92	Hauts de Seine
26	Drôme	65	Haute Pyrénées	93	Seine St Denis
27	Eure	66	Pyrénées Orientales	94	Val de Marne
32	Gers	67	Bas Rhin		
35	Ille et Vilaine	68	Haut Rhin		

The wireless LAN device cannot currently be used in any departments of mainland France other than those listed above.

Maximum allowable EIRP 802.11b wireless LAN cards in the mainland departments of France not shown in the table above are as follows: (See the ART website at www.art-telecom.fr for information on the French overseas territories.)

Frequency Ranges (MHz)	Indoors	Outdoors
2400 – 2446.5	10 mW	Not permitted
2446.5 – 2483.5	100 mW	100 mW on private property with Ministry of Defense approval

Japanese Notice

本装置は、第二種情報装置（住宅地域またはその隣接した地域において使用されるべき情報装置）で住宅地域での電波障害防止を目的とした情報処理装置等電波障害自主規制協議会（VCCI）基準に適合しております。
しかし、本装置をラジオ、テレビジョン受信機に、近接してご使用になると、受信障害の原因となることがあります。本書の説明にしたがって正しい取り扱いをしてください。

DGT Statement

根據交通部 低功率管理辦法 規定：

- 第十四條 經型式認證合格之低功率射頻電機，非經許可，公司、商號或使用者均不得擅自變更頻率、加大功率或變更原設計之特性及功能。
- 第十七條 低功率射頻電機之使用不得影響飛航安全及干擾合法通信，經發現有干擾現象時，應立即停用，並改善至無干擾時方得繼續使用。
- 第二十條 輸入、製造低功率射頻電機之公司、商號或使用者違反本辦法規定，擅自使用或變更無線電頻率、電功率者，除依電信法規定處罰外，電信總局並得撤銷其型式認證證明或型式認證標籤。

U.S. Regulations Governing the Use of Modems

This equipment complies with Part 68 of the FCC Rules. On this equipment is a label that contains, among other information, the FCC registration number and **Ringer Equivalence Number (REN)** for this equipment. You must, upon request, provide this information to your telephone company.

If your telephone equipment harms the telephone network, the Telephone Company may discontinue your service temporarily. If possible, they will notify in advance. But, if advance notice is not practical, you will be notified as soon as possible. You will be informed of your right to file a complaint with the FCC.

Your telephone company may make changes in its facilities, equipment, operations, or procedures that could affect proper operation of your equipment. If they do, you will be notified in advance to give you an opportunity to maintain uninterrupted telephone service.

The FCC prohibits this equipment to be connected to party lines or coin-telephone service.

In the event that this equipment should fail to operate properly, disconnect the equipment from the phone line to determine if it is causing the problem. If the problem is with the equipment, discontinue use and contact your dealer or vendor.

The FCC also requires the transmitter of a FAX transmission be properly identified (per FCC Rules Part 68, Sec 68.381 (C) (3)).

Japanese Modem Notice

本製品を日本で使用する場合は必ず日本国モードでご使用ください。
他国のモードをご使用になると電気通信事業法(技術基準)に違反す
行為となります。なお、ご購入時は初期値が日本国モードとなっており
ますので、そのままご利用ください。

U.K. Modem Compliance Information

This modem is approved by the secretary of state at the Department of Trade and Industry for connection to a single exchange line of the public switched telephone network run by certain licensed public telecommunication operators or system connected there to (Direct exchange lines only, not shared service or 1-1 carrier systems).

This modem is also suitable for connection to **P**rivate **A**utomatic **B**ranch **E**xchange (**PABX**), which return secondary proceeding indication.

If this modem is to be used with a PBX which has extension wiring owned by BT, connection of the modem the PBX can only be carried out by BT; or by the authorized maintainer of the PBX unless the authorized maintainer has been given 14 days written notice that the connection is to be made by another person; and that period of notification has expired.

This modem is suitable for use only on telephone lines proved with Loop Disconnect or Multi-Frequency Dialing Facilities.

Users of this modem are advised that the approval is for connection to the **PSTN** via the telephone line interface supplied with it. Connection of a modem to the **PSTN** by any other means will invalidate the approval.

There is no guarantee of correct working in all circumstances. Any difficulties should be referred to your supplier.

Some network operators require that intended users of their network request permission to connect and for the installation of an appropriate socket.

The **R**inger **E**quivalence **N**umber (**REN**) of this modem is 1. **REN** is guide to the maximum number of apparatus that can simultaneously be connected to one telephone line. The **REN** value of each apparatus is added together, and should not exceed 4. Unless otherwise marked, a telephone is assumed to have a **REN** of 1.

This modem is only approved for use of the following facilities:

- Storage of telephone numbers for retrieval by a predator mined code.
- Initial proceed indication detection.
- Automatic calling / automatic answering.
- Tone detection.
- Loud-speaking facility.

This modem is not approved for connection to U.K./private speech-band services. This modem does not support an automatic re-dial function. Any other usage will invalidate the approval of your modem, if as a result, it then ceases to confirm to the standards against which approval was granted. The approval of this modem is invalidated if the apparatus is subject to modification in any material way not authorized by the **BABT** or if it is used with, or connected to external software that have not been formally accepted by **BABT**.