



Raymarine®



RAY90/91 VHF

Installation & operation instructions

English (en-US)

Date: 12-2017

Document number: 81377-1

© 2017 Raymarine UK Limited





Trademark and patents notice

Raymarine, Tacktick, Clear Pulse, Truzoom, HSB, SeaTalk, SeaTalk^{hs}, SeaTalk^{ng}, Micronet, Raytech, Gear Up, Marine Shield, Seahawk, Autohelm, Automagic, and Visionality are registered or claimed trademarks of Raymarine Belgium.

FLIR, LightHouse, DownVision, SideVision, RealVision, Dragonfly, Quantum, Instalert, Infrared Everywhere, The World's Sixth Sense and ClearCruise are registered or claimed trademarks of FLIR Systems, Inc.

All other trademarks, trade names, or company names referenced herein are used for identification only and are the property of their respective owners.

This product is protected by patents, design patents, patents pending, or design patents pending.

Fair Use Statement

You may print no more than three copies of this manual for your own use. You may not make any further copies or distribute or use the manual in any other way including without limitation exploiting the manual commercially or giving or selling copies to third parties.





Software updates



Check the Raymarine website for the latest software releases for your product.
www.raymarine.com/software

Product documentation



The latest versions of all English and translated documents are available to download in PDF format from the website:
www.raymarine.com/manuals.
Please check the website to ensure you have the latest documentation.

Copyright ©2017 Raymarine UK Ltd. All rights reserved.

English (en-US)

Document number: 81377-1
AA:6819;2017-12-21T18:06:26





Product documentation



The latest versions of all English and translated documents are available to download in PDF format from the website:
www.raymarine.com/manuals.
Please check the website to ensure you have the latest documentation.

Copyright ©2017 Raymarine UK Ltd. All rights reserved.





Contents

Chapter 1 Important information 9

- Certified Installation 9
- FCC 9
 - Compliance Statement (Part 15.19) 9
 - FCC Interference Statement (Part 15.105 (b)) 9
- Industry Canada 9
 - Industry Canada (Français) 10
- Water ingress 10
- Disclaimer 10
- Declaration of Conformity 10
- Product disposal 11
- Warranty registration 11
- Technical accuracy 11

Chapter 2 Document and product information 13

- 2.1 Product documentation 14
 - User manuals Print Shop 14
 - Document illustrations 14
- 2.2 Applicable products 14
 - Required additional components 14
- 2.3 Product overview 15
- 2.4 Licensing 15
 - USA licensing requirements 15
 - Canada licensing requirements 15
 - Europe and rest of world licensing requirements 15
 - Additional information 15
- 2.5 Obtain MMSI (Maritime Mobile Service Identity) number 16
- 2.6 Automatic Transmitter Identification System (ATIS) 16

- 2.7 Parts supplied 16
- 2.8 Software updates 17
 - Checking software versions 17
 - Preparing the Raymic handset for the software update process 17

Chapter 3 Installation 19

- 3.1 Selecting a location 20
 - General location requirements 20
 - Antenna mounting and EME exposure 20
- 3.2 EMC installation guidelines 21
 - Suppression ferrites 21
 - Connections to other equipment 21
- 3.3 Product dimensions 21
 - Product dimensions - Base station 21
 - Product dimensions - speakers 21
 - Product dimensions - Raymic handset 22
- 3.4 Mounting 22
 - Tools required for installation 22
 - Mounting the Base station 22
 - Pass-through panel kit mounting 23
 - Raymic handset cradle mounting 23
 - Passive speaker mounting 23

Chapter 4 Cables and connections 25

- 4.1 General cabling guidance 26
 - Cable types and length 26
 - Routing cables 26
 - Strain relief 26





Circuit isolation	26
Cable shielding	26
Dust caps	26
Connections to other equipment	26
4.2 Connections overview	26
Bare end wire connections	27
4.3 Power connection	27
In-line fuse and thermal breaker ratings	27
Grounding	27
Power distribution	27
4.4 Handset station connection	29
Connecting handsets and cables	29
Handset extension cables	29
4.5 Passive speaker connection	30
4.6 NMEA 2000 / SeaTalkng® connection	30
Connecting SeaTalkng® cables	30
4.7 NMEA 0183 connection	31
4.8 Loud hailer connection	31
4.9 Connecting GNSS (GPS) and VHF antennas	32

Chapter 5 Getting started..... 33

5.1 Raymic handset controls	34
5.2 Powering the Base station	34
Powering the handset	34
5.3 Homescreen overview	35
Status bar symbols	35
Main menu overview	36
5.4 Shortcut list	37
Adjusting Brightness and Contrast	37
5.5 Shared Brightness	37

Enabling Shared Brightness	38
5.6 Initial startup	38
5.7 Selecting a language	38
5.8 Switching on the AIS receiver	39
5.9 Selecting a network type	39
5.10 Entering your MMSI number	39
5.11 Entering your ATIS ID	40
Enabling and disabling ATIS mode	40
5.12 Changing the radio region	41
5.13 Switching between high and low transmit power	41
5.14 GNSS (GPS) set up	42
Enabling and disabling the internal GNSS (GPS)	42
No GPS position data	42
Entering position manually	42
Selecting GPS information to display	42
Setting time format and offset	42

Chapter 6 Digital selective calling (DSC) 43

6.1 Digital Selective Calling (DSC)	44
6.2 Distress calls	45
Making a designated distress call	45
Making a distress call	45
Making a Mayday call	45
Cancelling a distress call before transmission	45
Cancelling a distress call after transmission	46
Receiving a distress call	46
Ignoring a distress call	46
Acknowledging a distress call	46
Manually relaying a distress call	47
Distress relays sent by other stations	47
6.3 Urgency calls	47





Making an urgency call.....	47
Receiving an urgency call.....	47
6.4 Safety calls.....	48
Making a safety call.....	48
Receiving a safety call.....	48
6.5 Individual (routine) calls.....	48
Making a routine DSC call.....	48
Receiving an individual (routine) call.....	48
6.6 Group calls.....	49
Making a group call.....	49
Receiving a group call.....	49
6.7 Position requests.....	49
Making a position request.....	49
Responding to a position request.....	49
Setting automatic response to position requests.....	50
6.8 Phonebook.....	50
Adding a phonebook entry.....	50
Editing a phonebook entry.....	50
Deleting a phonebook entry.....	50
6.9 Call logs.....	51
Accessing the call logs.....	51
6.10 Test calls.....	51
Making a test call.....	51
Receiving a test call.....	52
6.11 DSC set-up menu options.....	52

Chapter 7 VHF operations 53

7.1 Watch modes.....	54
Using watch modes.....	54
7.2 Scan Mode.....	54

Performing a scan.....	54
7.3 Priority channels.....	54
Switching between priority channels.....	54
Setting a second priority channel.....	54
7.4 Sensitivity.....	55
Switching sensitivity modes.....	55
7.5 Private channels.....	55
Selecting a private channel set.....	55
7.6 Automatic Transmitter Identification System (ATIS) and Marcom-C mode.....	55
Enabling and disabling ATIS mode.....	56
7.7 AIS receiver.....	56
Switching AIS on and off.....	56
7.8 Set-up menu options.....	57
Display Set-up menu.....	59
Shared Brightness menu.....	59

Chapter 8 Hailer, Fog horn, and Intercom 61

8.1 Hailer Fog Intercom menu.....	62
8.2 Loud Hailer.....	62
Using the hailer.....	62
8.3 Fog horn.....	62
Using the fog horn in manual mode.....	62
Using automatic fog horn modes.....	63
Switching off Fog Horn mode.....	63
8.4 Intercom.....	63
Using the intercom.....	63
Responding to the intercom.....	63

Chapter 9 Maintenance..... 65



9.1 Maintenance	66
Routine checks	66
Unit cleaning instructions	66
Chapter 10 Troubleshooting	67
10.1 Troubleshooting	68
Performing a system reset	68
System test	68
10.2 Power up troubleshooting	69
10.3 VHF Radio troubleshooting	71
10.4 GNSS (GPS) troubleshooting	72
GPS data output	72
Chapter 11 Technical support	73
11.1 Raymarine product support and servicing	74
11.2 Viewing product information	75
11.3 Learning resources	75
Chapter 12 Technical specification	77
12.1 Technical specification	78
12.2 Radio usage	79
Appendix A NMEA 0183 sentences	81
Appendix B NMEA 2000 PGN list	82
Appendix C MMSI Regulatory bodies and application submissions	84
Appendix D VHF Channels	86

Appendix E Phonetic alphabet	99
Appendix F Prowords	100





Chapter 1: Important information

Certified Installation

Raymarine recommends certified installation by a Raymarine approved installer. A certified installation qualifies for enhanced product warranty benefits. Contact your Raymarine dealer for further details, and refer to the separate warranty document packed with your product.



Warning: Product installation and operation

- This product must be installed and operated in accordance with the instructions provided. Failure to do so could result in personal injury, damage to your vessel and/or poor product performance.
- Raymarine recommends certified installation by a Raymarine approved installer. A certified installation qualifies for enhanced product warranty benefits. Contact your Raymarine dealer for further details, and refer to the separate warranty document packed with your product.



Warning: Potential ignition source

This product is NOT approved for use in hazardous/flammable atmospheres. Do NOT install in a hazardous/flammable atmosphere (such as in an engine room or near fuel tanks).



Warning: 12 Volt dc only

This product must only be connected to a **12 volt dc** power source.



Warning: Chassis grounding

Do NOT ground this product using the chassis ground terminal.

Grounding this product to a vessel's RF ground may cause galvanic corrosion.



Warning: Positive ground systems

Do not connect this unit to a system which has positive grounding.



Warning: Switch off power supply

Ensure the vessel's power supply is switched OFF before starting to install this product. Do NOT connect or disconnect equipment with the power switched on, unless instructed in this document.

FCC



Warning: FCC Warning (Part 15.21)

Changes or modifications to this equipment not expressly approved in writing by Raymarine Incorporated could violate compliance with FCC rules and void the user's authority to operate the equipment.

Compliance Statement (Part 15.19)

This device complies with Part 15 of the FCC Rules. Operation is subject to the following two conditions:

1. This device may not cause harmful interference.
2. This device must accept any interference received, including interference that may cause undesired operation.

FCC Interference Statement (Part 15.105 (b))

This equipment has been tested and found to comply with the limits for a Class B digital device, pursuant to Part 15 of the FCC Rules.

These limits are designed to provide reasonable protection against harmful interference in a residential installation. This equipment generates, uses, and can radiate radio frequency energy and, if not installed and used in accordance with the instructions, may cause harmful interference to radio communications. However, there is no guarantee that interference will not occur in a particular installation. If this equipment does cause harmful interference to radio or television reception, which can be determined by turning the equipment off and on, the user is encouraged to try to correct the interference by one of the following measures:

1. Reorient or relocate the receiving antenna.
2. Increase the separation between the equipment and receiver.
3. Connect the equipment into an outlet on a circuit different from that to which the receiver is connected.
4. Consult the dealer or an experienced radio / TV technician for help.

Innovation, Science and Economic Development Canada

This device complies with ISED License-exempt, RSS standard(s).

Operation is subject to the following two conditions:





1. This device may not cause interference; and
2. This device must accept any interference, including interference that may cause undesired operation of the device.

This Class B digital apparatus complies with Canadian ICES-003.

Innovation, Sciences et Développement économique Canada (Français)

Cet appareil est conforme aux normes d'exemption de licence RSS d'ISED.

Son fonctionnement est soumis aux deux conditions suivantes:

1. cet appareil ne doit pas causer d'interférence, et
2. cet appareil doit accepter toute interférence, notamment les interférences qui peuvent affecter son fonctionnement.

Cet appareil numérique de la classe B est conforme à la norme NMB-003 du Canada.



Warning: VHF Antenna isolation

To prevent galvanic corrosion your VHF antenna must be isolated from any vessel metalwork using a suitable insulated e.g. plastic, mounting bracket.

This radio complies with the ITU-R M493-13 requirements.



Warning: Maximum Permissible Exposure

Failure to observe these guidelines may expose those within the Maximum Permissible Exposure (MPE) radius to RF radiation absorption that exceeds the FCC MPE limit. It is the radio operator's responsibility to ensure that no person comes within this radius.

For optimal radio performance and minimal human exposure to Radio Frequency (RF) electromagnetic energy, you must ensure that the antenna is:

- connected to the radio before transmitting;
- located where it will be away from people;
- located at least 1.3meters (4.2ft.) from the radio's main unit.

Caution: Perform regular radio checks

Perform regular radio checks when using your vessel, as recommended in radio training and certification schemes and radio equipment rules of use.

Caution: Ensure proper radio use

Under no circumstances should a DSC distress alert be sent from your radio for test purposes. Such action is a violation of rules of use for radio equipment, and can result in heavy fines.

Water ingress

Water ingress disclaimer

Although the waterproof rating capacity of this product meets the stated IPX standard (refer to the product's *Technical Specification*), water intrusion and subsequent equipment failure may occur if the product is subjected to commercial high-pressure washing. Raymarine will not warrant products subjected to high-pressure washing.

Disclaimer

Raymarine does not warrant that this product is error-free or that it is compatible with products manufactured by any person or entity other than Raymarine.

Raymarine is not responsible for damages or injuries caused by your use or inability to use the product, by the interaction of the product with products manufactured by others, or by errors in information utilized by the product supplied by third parties.

Declaration of Conformity

FLIR Belgium BVBA declares that the radio equipment types Ray90 and Ray91 DSC VHF Radios, part numbers E70492 and E70493, are in compliance with the Radio Equipment Directive 2014/53/EU.

The original Declaration of Conformity certificate may be viewed on the relevant product page at www.raymarine.com/manuals.





Product disposal

Dispose of this product in accordance with the WEEE Directive.



The Waste Electrical and Electronic Equipment (WEEE) Directive requires the recycling of waste electrical and electronic equipment.

Warranty registration

To register your Raymarine product ownership, please visit www.raymarine.com and register online.

It is important that you register your product to receive full warranty benefits. Your unit package includes a bar code label indicating the serial number of the unit. You will need this serial number when registering your product online. You should retain the label for future reference.





Technical accuracy

To the best of our knowledge, the information in this document was correct at the time it was produced. However, Raymarine cannot accept liability for any inaccuracies or omissions it may contain. In addition, our policy of continuous product improvement may change specifications without notice. As a result, Raymarine cannot accept liability for any differences between the product and this document. Please check the Raymarine website (www.raymarine.com) to ensure you have the most up-to-date version(s) of the documentation for your product.





Chapter 2: Document and product information

Chapter contents

- [2.1 Product documentation on page 14](#)
- [2.2 Applicable products on page 14](#)
- [2.3 Product overview on page 15](#)
- [2.4 Licensing on page 15](#)
- [2.5 Obtain MMSI \(Maritime Mobile Service Identity\) number on page 16](#)
- [2.6 Automatic Transmitter Identification System \(ATIS\) on page 16](#)
- [2.7 Parts supplied on page 16](#)
- [2.8 Software updates on page 17](#)





2.1 Product documentation

The following documentation is applicable to your product:

Description	Part number
Installation and operation instructions	81377
Ray90 / Ray91 mounting template	87329

All documents are available to download in pdf format from the Raymarine® website: www.raymarine.com/manuals.

User manuals Print Shop

Raymarine provides a Print Shop service, enabling you to purchase a high-quality, professionally-printed manual for your Raymarine product.

Printed manuals are ideal for keeping onboard your vessel, as a useful source of reference whenever you need assistance with your Raymarine product.

Visit <http://www.raymarine.co.uk/view?id=5175> to order a printed manual, delivered directly to your door.

For further information about the Print Shop, please visit the Print Shop FAQ pages: <http://www.raymarine.co.uk/view?id=5751>.

Note:

- Accepted methods of payment for printed manuals are credit cards and PayPal.
- Printed manuals can be shipped worldwide.
- Further manuals will be added to the Print Shop over the coming months for both new and legacy products.
- Raymarine user manuals are also available to download free-of-charge from the Raymarine website, in the popular PDF format. These PDF files can be viewed on a PC / laptop, tablet, smartphone, or on the latest generation of Raymarine multifunction displays.

Document illustrations

Your product and if applicable, its user interface may differ slightly from that shown in the illustrations in this document, depending on product variant and date of manufacture.

All images are provided for illustration purposes only.

2.2 Applicable products

This document is applicable to the following products:

Name	Part number	Features
Ray90	E70492	<ul style="list-style-type: none"> • Built-in GNSS (GPS and GLONASS) receiver • Up to 2 wired handset stations • Loud hailer connection • SeaTalkng® / NMEA 2000 connection • NMEA 0183 connection
Ray91	E70493	<p>Same as Ray90 above, with additional:</p> <ul style="list-style-type: none"> • Built-in AIS receiver

Required additional components

Your product requires a VHF and GNSS (GPS) antenna to be connected.

Part number	Description
A80288	Passive GNSS (GPS) antenna
N/A	3 rd Party VHF antenna





2.3 Product overview

The Ray90 and Ray91 are 12 V dc, Class D Digital Selective Calling (DSC) VHF radios. DSC enables you to make and receive calls to a specific radio, and to transmit and receive position information to and from a selected radio. DSC also allows transmission of a distress alert, to all radios within range, at the touch of a button. Once a DSC request is sent and acknowledged voice communication is carried out on the channel chosen by the caller. The radio can transmit and receive on all available US, Canadian, International and Private marine VHF channels.

The Ray90 and Ray91 include a built-in GNSS (GPS) receiver.

The Ray91 also includes a built-in AIS receiver.

Your radio includes a base station with 2 x wired handset connections.

With an optional loud hailer connected the radio can also be used as a fog horn or loud public address (PA) system.

2.4 Licensing

Prior to using this product please check your national requirements for both operator and equipment licensing.

USA licensing requirements

FCC station license requirement

An FCC Ship Radio Station License and Call Sign are not required for most recreational vessels travelling in US waters. However, you must obtain a license if your vessel travels to foreign ports.

Ships that use MF/HF single side-band radio, satellite communications, or telegraphy must be licensed by the FCC. You can obtain a Station License by filing FCC Form 605.

Canada licensing requirements

Industry Canada license requirement

You do not need a license to operate this product within the sovereign waters of Canada or the United States of America (USA). You will need a license to operate this radio outside of Canada or the USA. To obtain Industry Canada licensing information, contact the nearest field or regional office, or write to:

Industry Canada Radio Regulatory Branch
Attention: DOSP
300 Slater Street
Ottawa, Ontario
Canada, KIA 0C8

Europe and rest of world licensing requirements

Regulations in some areas require that an Operator's license is obtained before operating a VHF radio. It is your responsibility to determine whether a license is required in your area before operating this equipment.

Additional information

The following additional information is required for completing a license application in Canada and the USA.

Industry Canada certification number	4069B-RAY90D
FCC ID	PJ5-RAY90
FCC Type accepted	Parts 2, 15 and 80
Output power	1 watt (low) and 25 watt (high)
Modulation	FM
Frequency range	155.500 MHz to 163.275 MHz



2.5 Obtain MMSI (Maritime Mobile Service Identity) number

Before commencing installation ensure you have obtained a MMSI number for your vessel.

A MMSI is a 9 digit number which is sent over a radio frequency channel in order to identify the originating vessel/station. If your vessel already has a MMSI number (used for a VHF DSC radio) then the same MMSI number must be used to program your product.

Note:

If a MMSI number is not entered, the DSC functionality of your radio will be disabled.

In the United States of America, the MMSI and Static Data must be entered only by a Raymarine® dealer or other appropriately qualified installer of marine communications equipment on board vessels. The user is NOT authorized to do this.

In some areas, a radio operator licence is required before a MMSI number will be issued. You can request a MMSI number from same agency that issues radio or Ship Radio licences in your area.

In Europe and other parts of the world outside of the United States of America, the MMSI and Static data can be set up by the user.

For further details, refer to the relevant Telecommunications Regulatory Body for your area.

Refer to [Appendix C MMSI Regulatory bodies and application submissions](#)

for a list of contacts for obtaining MMSI numbers for some areas.



Warning: MMSI entry

You can only enter a MMSI number once, if you enter the number incorrectly or need to change your MMSI number, the unit will require re-programming by an authorized dealer.

2.6 Automatic Transmitter Identification System (ATIS)

Your product includes ATIS functionality for use on the inland waterways of contracting governments of the "Regional Arrangement on the Radiocommunication Service for Inland Waterways" — also known as "RAINWAT".

ATIS adds data at the end of radio transmissions that identifies your station. ATIS operation can be turned on or off as needed via the radio's menu.

An ATIS ID can be obtained from the same agency that issues radio operator licenses in your area.

Your ATIS ID should be programmed into your product using the instructions provided.

Note:

Contracting RAINWAT countries include: Austria, Belgium, Bulgaria, Croatia, the Czech Republic, France, Germany, Hungary, Luxembourg, Moldova, Montenegro, the Netherlands, Poland, Romania, Serbia, the Slovak Republic and Switzerland.

Note:

When ATIS is enabled, certain programming steps have been implemented to protect the integrity of the RAINWAT agreement, including the blocking of DSC functions when ATIS is enabled.

2.7 Parts supplied

The following parts are supplied with your product. Please ensure your box contents are correct before proceeding with the installation.

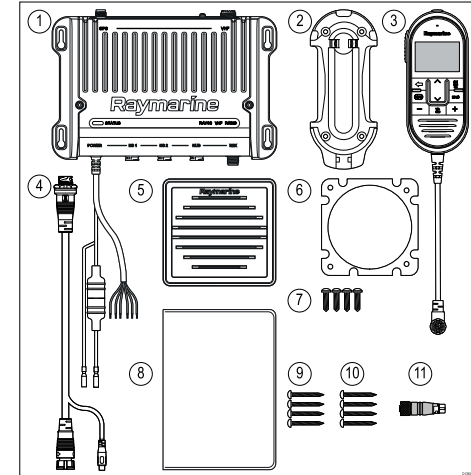

1. Ray90 / Ray91 VHF DSC Radio (including fitted power and data cable)
2. Raymic handset cradle
3. Raymic handset
4. Raymic handset adaptor cable (12 pin female to 12 pin male with RCA Audio)
5. Passive speaker
6. Passive speaker mounting gasket
7. Passive speaker mounting screws x 4
8. Documentation
9. VHF radio mounting screws x 4
10. Handset cradle mounting screws x 4
11. DeviceNet to SeaTalkng® adaptor



2.8 Software updates

Raymarine periodically releases software updates for its products. These updates can provide new and enhanced features and also improve product performance and usability. You should ensure that you have the latest software for your products by regularly checking the website for new software. The software update process requires a compatible MFD powered by LightHouse™ 2 release 13 or greater, or LightHouse™ 3.

Check the Raymarine website regularly for software updates for your products: www.raymarine.com/software.

The MFD used to perform the software update must be the designated Data master and be connected via SeaTalkng® / NMEA 2000 to the product being updated.

Please refer to the operation instructions for your MFD / operating system version for details on how to perform the software update.

If in doubt as to the correct procedure for updating your product software, refer to your dealer or Raymarine technical support.

Caution: Installing software updates

The software update process is carried out at your own risk. Before initiating the update process ensure you have backed up any important files.

Ensure that the unit has a reliable power supply and that the update process is not interrupted.

Damage caused by incomplete updates are not covered by Raymarine warranty.

By downloading the software update package, you agree to these terms.

Checking software versions

You can check the software version of your radio and any connected Raymic handset.

From the Homescreen:

Document and product information

1. Select **Menu > Set-up > Maintenance > About this unit**.
2. Scroll down.

The Base station's and Handset's software versions are displayed.

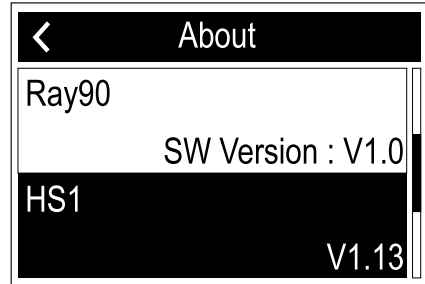

Preparing the Raymic handset for the software update process

The Raymic must be placed in programming mode to enable its software to be updated.

1. Power off your MFD.
2. Power on the Radio.
3. Ensure the Raymic handset is powered off.
4. Press and hold the **Distress** and **PTT** buttons on the Handset.
5. Press the Handset's **Power** button for 1 second, until the backlight turns on, and then release all three buttons.

The handset is now in programming mode, in programming mode the handset's screen remains blank and the backlight will briefly flash off, approximately once every 5 seconds. The handset will now be updated at the same time as the Base station.

6. Power your MFD on and follow the software update process described in your MFD's operation instructions.





7. Once the software update is complete, Power cycle your Radio and check the software version for both the Base station and Handset is correct.





Chapter 3: Installation

Chapter contents

- [3.1 Selecting a location on page 20](#)
- [3.2 EMC installation guidelines on page 21](#)
- [3.3 Product dimensions on page 21](#)
- [3.4 Mounting on page 22](#)



3.1 Selecting a location



Warning: Potential ignition source

This product is NOT approved for use in hazardous/flammable atmospheres. Do NOT install in a hazardous/flammable atmosphere (such as in an engine room or near fuel tanks).

General location requirements

When selecting a location for the unit it is important to consider a number of factors.

Ventilation requirements

To provide adequate airflow:

- Ensure that equipment is mounted in a compartment of suitable size.
- Ensure that ventilation holes are not obstructed.
- Ensure adequate separation of equipment.

Mounting surface requirements

Ensure units are adequately supported on a secure surface. Do NOT mount units or cut holes in places which may damage the structure of the vessel.

Water ingress

Ray90/91 Base station

Although the Base station is waterproof to IPx6 and IPx7, it is recommended that the Base station is mounted below decks, in an area protected from prolonged and direct exposure to rain and salt spray.

Raymic Handset

The Handset has been designed to be mounted above or below decks and is rated to IPx6 and IPx7.

Passive speaker

The speakers has been designed to be mounted above or below decks and are rated to IPx6 and IPx7.

Cable routing requirements

Ensure the unit is mounted in a location which allows proper routing and connection of cables:

- Minimum cable bend radius of 100 mm (3.94 in) is required unless otherwise stated.
- Use cable supports to prevent stress on connectors.

Electrical interference

Select a location that is far enough away from devices that may cause interference, such as motors, generators and radio transmitters/receivers.

Power supply

Select a location that is as close as possible to the vessel's DC power supply. This will help to keep cable runs to a minimum.

RF interference

Certain third-party external electrical equipment can cause Radio Frequency (RF) interference with GNSS (GPS), AIS or VHF devices, if the external equipment is not adequately insulated and emits excessive levels of electromagnetic interference (EMI).

Some common examples of such external equipment include LED spot or strip lights, and terrestrial TV tuners.

To minimize interference from such equipment:

- Keep it as far away from GNSS (GPS), AIS or VHF devices as possible.
- Ensure that any power cables for external equipment are not entangled with the power or data cables for these devices.
- Consider fitting one or more high frequency suppression ferrites to the EMI-emitting device. The ferrite(s) should be rated to be effective in the range 100 MHz to 2.5 GHz, and should be fitted to the power cable and any other cables exiting the EMI-emitting device, as close as possible to the position where the cable exits the device.

Compass safe distance

When choosing a suitable location for your product you should aim to maintain the maximum possible distance between the product and any installed compass. This distance should be at least 1 m (3 ft) in all directions. For smaller vessels it may not be possible to achieve this distance. In this situation ensure that the compass is not affected by the product when it is powered on.

Antenna mounting and EME exposure

Ensure that your VHF antenna is connected to the radio before transmission.

Raymarine® declares a Maximum Permissible Exposure (MPE) radius of 1.3meters (4.2ft.) for this system, assuming 25 watts output to an omnidirectional antenna of 3dBi gain or less.

For watercraft with suitable structures, the antenna base must be at least 3.8 meters (12.5 ft) above the main deck to meet the MPE for persons up to 2 metres (6.6 ft) tall. For watercraft without such structures, the antenna must be mounted so that its base is a minimum of 1.3meters (4.2ft.) vertically from heads of all persons.

The antenna must be isolated from the vessel's metalwork using an insulated (e.g. plastic) mounting bracket.





3.2 EMC installation guidelines

Raymarine® equipment and accessories conform to the appropriate Electromagnetic Compatibility (EMC) regulations, to minimize electromagnetic interference between equipment and minimize the effect such interference could have on the performance of your system

Correct installation is required to ensure that EMC performance is not compromised.

Note:

In areas of extreme EMC interference, some slight interference may be noticed. Where this occurs the product and the source of the interference should be separated by a greater distance.

For **optimum** EMC performance we recommend that wherever possible:

- Raymarine® equipment and cables connected to it are:
 - At least 1 m (3 ft) from any equipment transmitting or cables carrying radio signals e.g. VHF radios, cables and antennas. In the case of SSB radios, the distance should be increased to 2 m (7 ft).
 - More than 2 m (7 ft) from the path of a Radar beam. A Radar beam can normally be assumed to spread 20 degrees above and below the radiating element.
- The product is supplied power from a separate battery from that used for engine start. This is important to prevent erratic behavior and data loss which can occur if the engine start does not have a separate battery.
- Only Raymarine® specified cables are used.
- Cables are not cut or extended, unless doing so is detailed in the installation instructions.

Note:

Where constraints on the installation prevent any of the above recommendations, always ensure the maximum possible separation between different items of electrical equipment, to provide the best conditions for EMC performance throughout the installation.

Installation

Suppression ferrites

- Raymarine cables may be pre-fitted or supplied with suppression ferrites. These are important for correct EMC performance. If ferrites are supplied separately to the cables (i.e. not pre-fitted), you must fit the supplied ferrites, using the supplied instructions.
- If a ferrite has to be removed for any purpose (e.g. installation or maintenance), it must be replaced in the original position before the product is used.
- Use only ferrites of the correct type, supplied by Raymarine or its authorized dealers.
- Where an installation requires multiple ferrites to be added to a cable, additional cable clips should be used to prevent stress on the connectors due to the extra weight of the cable.

Connections to other equipment

Requirement for ferrites on non- cables.

If your is to be connected to other equipment using a cable not supplied by , a suppression ferrite **MUST** always be attached to the end of the cable near the .

3.3 Product dimensions

Product dimensions - Base station

The Base station dimensions are listed below.

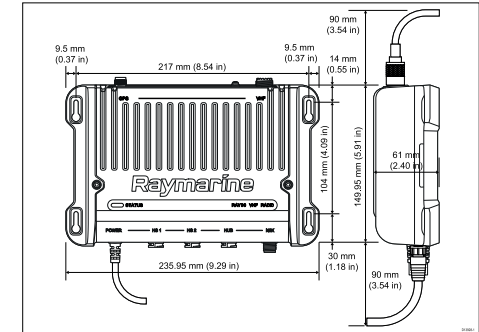

The Base station includes a fitted power and data cable, The power cable length is 1.2 m (3.94 ft) sand the Data cable length is 420 mm (1.38 ft).

Product dimensions - speakers

The dimensions for the Passive speaker are shown below.

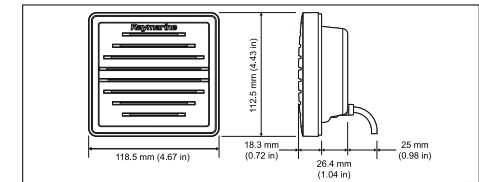

The Passive speaker includes a fitted 2 m (6.56 ft) audio cable terminated with a male RCA plug.





Product dimensions - Raymic handset

The Raymic handset dimensions for both cradle mounting and clip mounting are provided.

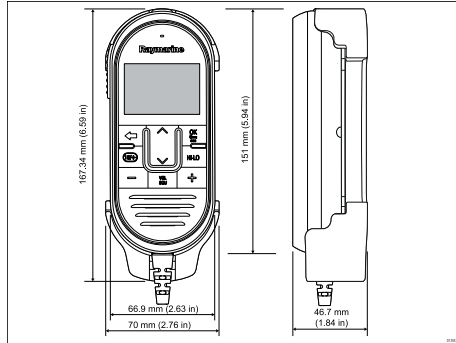

The Raymic handset is fitted with a coiled cable. Ensure sufficient space is available below the desired mounting area to accommodate the cable.

3.4 Mounting

Tools required for installation

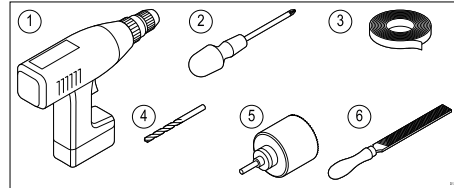

1. Power drill
2. Pozi-drive screwdriver
3. Adhesive tape
4. Suitable size drill bit
5. 89 mm (3 1/2 in) Hole saw (used for speaker mounting)
6. File (for speaker cut-out)

Mounting the Base station

Follow the steps below to mount the Base station.

Before mounting the Base station ensure that you have:

- selected a suitable location (a clear, flat surface is required).
- identified the location for additional components, such as the Handset or Speaker etc.
- identified the relevant cable connections and route that the cables will take.

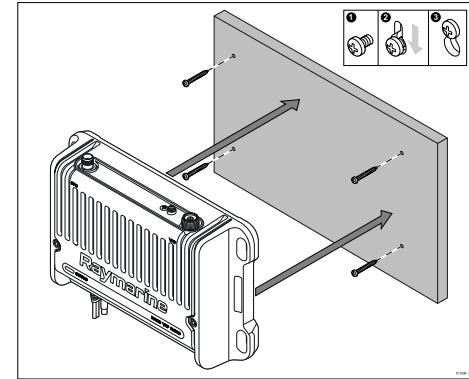

1. Using the supplied mounting template, mark the location of the fixing holes on the mounting surface.
2. Drill holes for the mounting fixings using a drill with a suitable sized drill bit.
3. Screw the fixings approximately half way into the holes in the mounting surface.
4. Place the Base station over the fixings screws and push down to lock into position.
5. Fully tighten the screws.
6. Connect the necessary cables.





Pass-through panel kit mounting

When installing the Fistic or the optional Raymic handset, the pass-through panel kit should be used to secure the cable to any panels the cable has to pass through.

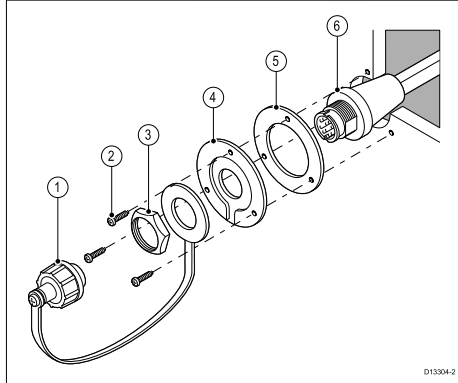

1	Splash-proof dust cap with lanyard
2	Mounting plate fixings x 3
3	Mounting plate nut
4	Mounting plate
5	Mounting plate gasket
6	Extension cable

1. Check the selected location for the Mounting plate, a clear flat area is required.
2. Using a pencil, offer up the Mounting plate to the desired location and mark the location of the screw holes and the center hole on the mounting panel.
3. Drill the mounting holes using a suitable size drill bit.
4. Drill the center hole using a 25 mm (1 in.) hole cutting saw.
5. Pull the connector end of the cable through the hole in the mounting surface.

6. Place the Mounting plate gasket over the end of the connector.
7. With the recessed side facing away from the mounting panel, place the Mounting plate over the end of the connector.
8. Place the lanyard end of the Splash-proof dust cap over the connector, ensuring the lanyard sits in the recess in the Mounting plate.
9. Place the Mounting plate nut over the connector and tighten clockwise using a 13/16 in. (21 mm) socket wrench, being careful not to damage the plastic nut by overtightening.
10. Secure the Mounting plate to the mounting surface using the supplied screws.
11. Attach the Handset / Fistic connector to the cable connector and rotate the locking collar clockwise to secure.
12. Connect the opposite end of the cable to the required connector either on the Base station or to another pass-through panel mounting plate connector.

Note: Drill bit, tap size and tightening torque is dependent on the thickness and type of material the unit is to be mounted on.

Raymic handset cradle mounting

Before mounting the unit, ensure that you have:

- Selected a suitable location, ensuring there is nothing behind the mounting surface that may be damaged when drilling.
- Identified the cable connections and route that the cables will take.

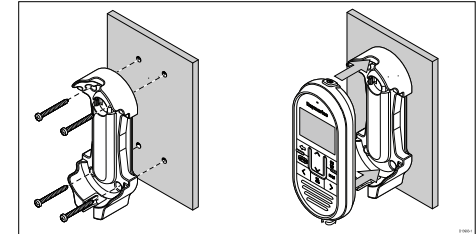

1. Check the selected location for the mounting cradle, a clear flat area is required, with sufficient space around it to place and remove the Handset.
2. Using a pencil, offer up the cradle to the desired location and mark the location of the screw holes on the mounting surface.
3. Drill the mounting holes using a suitable size drill bit.
4. Hold the cradle in place and secure using the screws provided.
5. Place the Handset into the cradle until it clicks into position.

Passive speaker mounting

Follow the steps below to mount the Passive speaker. Before mounting the Passive speaker ensure that you have:

- selected a suitable location (a clear, flat surface is required).
- identified the location for additional components, such as the Handset or Base station etc.
- identified the relevant cable connections and the route that the cables will take.
- removed the bezel.



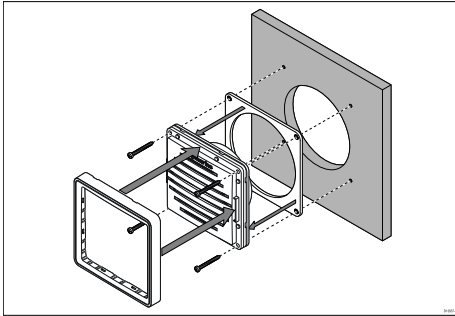

1. Using the supplied mounting template, mark the location of the cut out and fixing holes on the mounting surface.
2. Using a 89 mm (3 ½ in) hole saw, drill out the centre cut out area indicated on the mounting template.
3. Drill holes for the fixings, using a drill with a suitable sized bit.
4. Ensure that the unit fits into the removed area and then file around the cut edge until smooth.
5. Peel the backing off of the supplied gasket and place the adhesive side of the gasket onto the rear of the speaker, pressing firmly onto the flange.
6. Connect the relevant cable to the speaker.
7. Slide the speaker into place and secure using the fixings provided.
8. Fit the Bezel, ensuring it clips into place on all 4 sides.





Chapter 4: Cables and connections

Chapter contents

- [4.1 General cabling guidance on page 26](#)
- [4.2 Connections overview on page 26](#)
- [4.3 Power connection on page 27](#)
- [4.4 Handset station connection on page 29](#)
- [4.5 Passive speaker connection on page 30](#)
- [4.6 NMEA 2000 / SeaTalkng® connection on page 30](#)
- [4.7 NMEA 0183 connection on page 31](#)
- [4.8 Loud hailer connection on page 31](#)
- [4.9 Connecting GNSS \(GPS\) and VHF antennas on page 31](#)





4.1 General cabling guidance

Cable types and length

It is important to use cables of the appropriate type and length

- Unless otherwise stated use only standard cables of the correct type, supplied by Raymarine.
- Ensure that any non-Raymarine cables are of the correct quality and gauge. For example, longer power cable runs may require larger wire gauges to minimize voltage drop along the run.

Routing cables

Cables must be routed correctly, to maximize performance and prolong cable life.

- Do NOT bend cables excessively. Wherever possible, ensure a minimum bend diameter of 200 mm (8 in) / minimum bend radius of 100 mm (4 in).

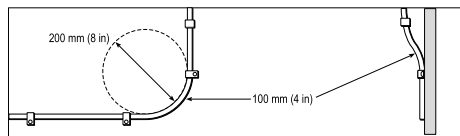

- Protect all cables from physical damage and exposure to heat. Use trunking or conduit where possible. Do NOT run cables through bilges or doorways, or close to moving or hot objects.
- Secure cables in place using tie-wraps or lacing twine. Coil any extra cable and tie it out of the way.
- Where a cable passes through an exposed bulkhead or deckhead, use a suitable watertight feed-through.
- Do NOT run cables near to engines or fluorescent lights.

Always route data cables as far away as possible from:

- other equipment and cables,

- high current carrying AC and DC power lines,
- antennae.

Strain relief

Ensure adequate strain relief is provided. Protect connectors from strain and ensure they will not pull out under extreme sea conditions.

Circuit isolation

Appropriate circuit isolation is required for installations using both AC and DC current:

- Always use isolating transformers or a separate power-inverter to run PC's, processors, displays and other sensitive electronic instruments or devices.
- Always use an isolating transformer with Weather FAX audio cables.
- Always use an isolated power supply when using a 3rd party audio amplifier.
- Always use an RS232/NMEA converter with optical isolation on the signal lines.
- Always make sure that PC's or other sensitive electronic devices have a dedicated power circuit.

Cable shielding

Ensure that all cables are properly shielded and that the cable shielding is undamaged.

Dust caps

To prevent potential water ingress, connectors not in use should be protected using the supplied dust caps.

Connections to other equipment

Requirement for ferrites on non-Raymarine cables

If your Raymarine equipment is to be connected to other equipment using a cable not supplied by Raymarine, a suppression ferrite MUST always be attached to the cable near the Raymarine unit.

4.2 Connections overview

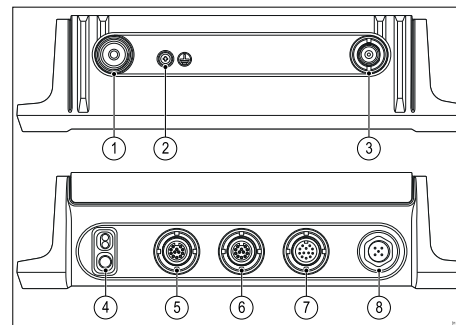

	Connection	Connects to	Suitable cables
1	GNSS (GPS) antenna connection	Passive GNSS antenna	GNSS antenna's fitted cable.
2	Earth stud	DO NOT CONNECT	N/A
3	VHF antenna connection	VHF antenna or Splitter	VHF antenna's fitted cable.
4	Power and data connection	<ul style="list-style-type: none"> • 12 V dc power supply • NMEA 0183 devices • Loud Hailer 	<ul style="list-style-type: none"> • Suitable power extension or circuit breaker. • cable supplied with your NMEA 0183 device • Loud hailer's fitted cable





	Connection	Connects to	Suitable cables
5	HS 1 (Handset station 1) connection	Raymic handset or Adaptor cable	Raymic handset's fitted cable.
6	HS 2 (Handset station 2) connection	Raymic handset or Adaptor cable	Raymic handset's fitted cable.
7	Hub connection	DO NOT CONNECT	
8	N2K (NMEA 2000) connection	SeaTalkng® / NMEA 2000 backbone	The supplied DeviceNet to SeaTalkng® adaptor cable or a DeviceNet spur cable.

Bare end wire connections

Your product is supplied with bare end wire connections. You must ensure that ALL bare end wires are adequately protected from short circuit and water ingress.

Bare ended wire connections

It is recommended that bare ended wire connections are made by soldering or using crimp connectors and then protected by wrapping the connection in insulation tape.

Unused bare ended wires

Any unused bare ended wires should be folded back and wrapped in insulation tape.

4.3 Power connection

The power supply should be connected as shown below:

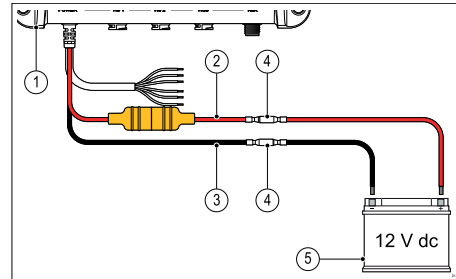

1. Base station
2. Power supply positive (+) Red wire
3. Power supply negative (-) Black wire
4. Suitable waterproof connection (Base station is supplied with bullet crimps on power supply wires.)
5. 12 V dc power source



Warning: 12 Volt dc only

This product must only be connected to a **12 volt dc** power source.



Warning: Positive ground systems

Do not connect this unit to a system which has positive grounding.

In-line fuse and thermal breaker ratings

The following in-line fuse and thermal breaker ratings apply to your product:

In-line fuse rating	Thermal breaker rating
10 A	7 A (if only connecting one device)

Note:

- The suitable fuse rating for the thermal breaker is dependent on the number of devices you are connecting. If in doubt consult an authorized **Raymarine®** dealer.
- Your product's power cable may have fitted in-line fuse, if not then you can add an in-line fuse to the positive wire of your products power connection.

Grounding

This product is grounded through the 0 V dc negative wire on the power cable and does not require a drain (shield) to be connected to the base station's ground terminal.

Power distribution

Recommendations and best practice.

- The product is supplied with a power cable, either as a separate item or a captive cable permanently attached to the product. Only use the power cable supplied with the product. Do NOT use a power cable designed for, or supplied with, a different product.
- Refer to the *Power connection* section for more information on how to identify the wires in your product's power cable, and where to connect them.
- See below for more information on implementation for some common power distribution scenarios.





Important:

When planning and wiring, take into consideration other products in your system, some of which (e.g. sonar modules) may place large power demand peaks on the vessel's electrical system.

Note:

The information provided below is for guidance only, to help protect your product. It covers common vessel power arrangements, but does NOT cover every scenario. If you are unsure how to provide the correct level of protection, please consult an authorized Raymarine dealer or a suitably qualified professional marine electrician.

Implementation — direct connection to battery

- The power cable supplied with your product may be connected directly to the vessel's battery, via a suitably rated fuse or breaker.
- The power cable supplied with your product may NOT include a separate drain wire. If this is the case, only the power cable's red and black wires need to be connected.
- If the supplied power cable is NOT fitted with an inline fuse, you MUST fit a suitably rated fuse or breaker between the red wire and the battery's positive terminal.
- Refer to the inline fuse ratings provided in the product's documentation.
- If you need to extend the length of the power cable supplied with your product, ensure you observe the dedicated *Power cable extensions* advice provided in the product's documentation.

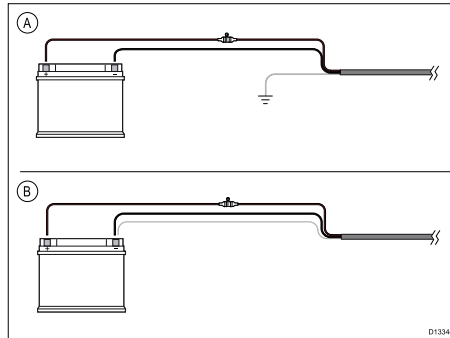

A Battery connection scenario A: suitable for a vessel with a common RF ground point. In this scenario, if your product's power cable is supplied with a separate drain wire then it should be connected to the vessel's common ground point.

B Battery connection scenario B: suitable for a vessel without a common grounding point. In this case, if your product's power cable is supplied with a separate drain wire then it should be connected directly to the battery's negative terminal.

Implementation — connection to distribution panel

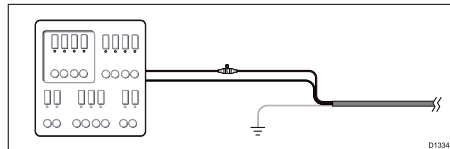

- Alternatively, the supplied power cable may be connected to a suitable breaker or switch on the vessel's distribution panel or factory-fitted power distribution point.
- The distribution point should be fed from the vessel's primary power source by 8 AWG (8.36 mm²) cable.

- Ideally, all equipment should be wired to individual suitably-rated thermal breakers or fuses, with appropriate circuit protection. Where this is not possible and more than 1 item of equipment shares a breaker, use individual in-line fuses for each power circuit to provide the necessary protection.

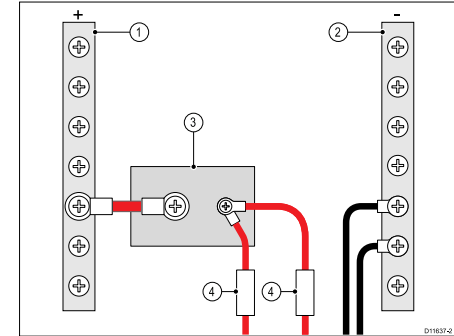

1	Positive (+) bar
2	Negative (-) bar
3	Circuit breaker
4	Fuse

- In all cases, observe the recommended breaker / fuse ratings provided in the product's documentation.

Important:

Be aware that the suitable fuse rating for the thermal breaker or fuse is dependent on the number of devices you are connecting.

Power cable extension

If you need to extend the length of the power cable supplied with your product, ensure you observe the following advice:

- The power cable for each unit in your system should be run as a separate, single length of 2-wire cable





from the unit to the vessel's battery or distribution panel.

- For power cable extensions, it is recommended that a **minimum** wire gauge of 16 AWG (1.31 mm²). For cable runs longer than 15 meters, you may need to consider a thicker wire gauge (e.g. 14 AWG (2.08 mm²), or 12 AWG (3.31 mm²)).
- An important requirement for all lengths of power cable (including any extension) is to ensure that there is a continuous **minimum** voltage of 10.8 V at the product's power connector, with a fully flat battery at 11 V.

Important: Be aware that some products in your system (such as sonar modules) can create voltage peaks at certain times, which may impact the voltage available to other products during the peaks.

Grounding

Ensure that you observe any separate grounding advice provided in the product's documentation.

More information

It is recommended that best practice is observed in all vessel electrical installations, as detailed in the following standards:

- BMEA Code of Practice for Electrical and Electronic Installations in Boats
- NMEA 0400 Installation Standard
- ABYC E-11 AC & DC Electrical Systems on Boats
- ABYC A-31 Battery chargers and Inverters
- ABYC TE-4 Lightning Protection

Cables and connections

4.4 Handset station connection

A Raymic handset can be connected to each Handset station connection (HS 1 / HS 2). Your radio is supplied with the equipment to create a full handset station (i.e.: Raymic handset, Adaptor cable and Passive speaker). Additional accessories can be purchased to create a second handset station.

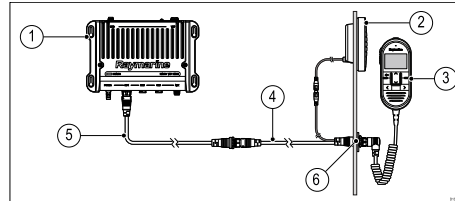

1. Base station
2. Passive speaker (1 x supplied and available as accessory: A80542)
3. Raymic handset (1 x supplied and available as accessory: A80289)
4. Handset station adaptor cable with RCA Audio (1 x supplied and available as accessory: A80297)
5. Raymic handset extension cable (Available optional accessories: A80290, A80291 or A80292)
6. Panel mount fixings kit (1 x supplied and available as a Spare: R70438)

Connecting handsets and cables

Follow the steps below to connect handsets and extension cables together.

1. If fitted, unscrew and remove the dust cap from the relevant connector.
2. Ensure the cable connectors are correctly orientated, before insertion.
3. Ensure connectors are fully inserted, before locking..
4. Tighten locking collars by Rotating clockwise.

Handset extension cables

Handset station cabling can be extended using approved extension cables.

The maximum length of cable from the Handset to the Base station should not exceed 50 m (164 ft)



29





4.5 Passive speaker connection

A passive speaker can be connected to a handset station using the RCA audio connector available on the Handset adaptor cable.

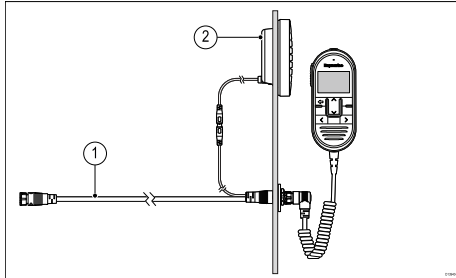

1. Raymic handset adaptor cable (1 x supplied and available as an accessory: A80297)
2. Passive speaker (1 x supplied and available as an accessory: A80542)

The Passive speaker includes a 2m (6.56 ft) audio cable terminated with a Female RCA connector.

4.6 NMEA 2000 / SeaTalkng® connection

Your product can transmit data to devices connected on SeaTalkng® or NMEA 2000 CAN bus networks. Connection is established using the DeviceNet connector located on the bottom of the unit.

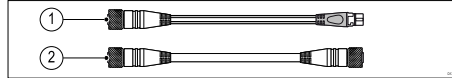

1. Use the supplied DeviceNet to SeaTalkng® adaptor cable to connect your product to an available spur connection on a SeaTalkng® backbone.
2. Alternatively you can connect your product to a NMEA 2000 backbone using a standard DeviceNet cable (not supplied).

Note:

1. The product must be connected to a correctly terminated backbone. You cannot connect your product directly to a MFD.
2. Refer to the instructions supplied with your SeaTalkng® / NMEA 2000 device for details on creating a backbone.

Connecting SeaTalkng® cables

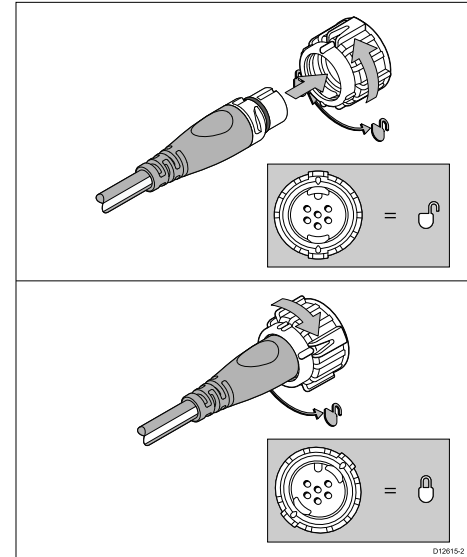

1. Rotate the locking collar on the unit to the unlocked position.
2. Ensure the cable's connector is correctly oriented.
3. Fully insert the cable connector.
4. Rotate locking collar clockwise (2 clicks) until it is in the locked position.





4.7 NMEA 0183 connection

The NMEA 0183 wires can be used to connect the unit to a NMEA 0183 GNSS (GPS) receiver or MFD.

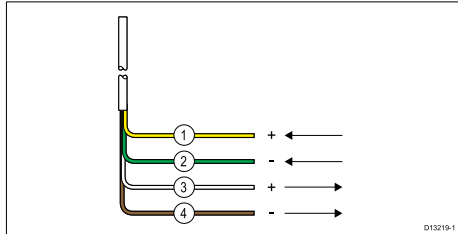

1. Yellow = Receive positive (+) wire
2. Green = Receive negative (-) wire
3. White = Transmit positive (+) wire
4. Brown = Transmit negative (-) wire

The NMEA wires should be connected to a compatible device as shown in the table below:

NMEA 0183 wires		NMEA 0183 device
Receive positive (+)	to	Transmit positive (+)
Receive negative (-)	to	Transmit negative (-)
Transmit positive (+)	to	Receive positive (+)
Transmit negative (-)	to	Receive negative (-)

4.8 Loud hailer connection

A Loud hailer (M95435) can be connected to the radio using the loud hailer wires.

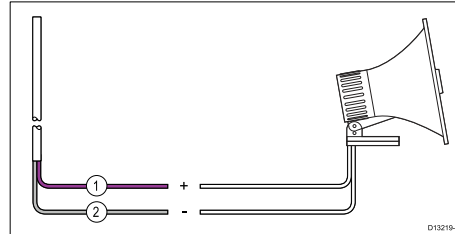

1	Positive (+) hailer wire (Purple)
2	Negative (-) hailer wire (Gray)





4.9 Connecting GNSS (GPS) and VHF antennas

The radio must be connected to suitable GNSS and VHF antennas (not supplied). The antenna connections must be protected so it cannot come into contact with any grounded bare metal.

Pre-requisites:

- Ensure you have installed your antennas in accordance with the instructions supplied with the antennas.
 - Ensure the cables have been properly routed to the Base station and that sufficient cable length is available to make the connections.
1. Plug the antenna connector into the relevant antenna connection on the Base station.
 2. Secure by tightening the locking collars.





Chapter 5: Getting started

Chapter contents

- 5.1 Raymic handset controls on page 34
- 5.2 Powering the Base station on page 34
- 5.3 Homescreen overview on page 35
- 5.4 Shortcut list on page 37
- 5.5 Shared Brightness on page 37
- 5.6 Initial startup on page 38
- 5.7 Selecting a language on page 38
- 5.8 Switching on the AIS receiver on page 39
- 5.9 Selecting a network type on page 39
- 5.10 Entering your MMSI number on page 39
- 5.11 Entering your ATIS ID on page 40
- 5.12 Changing the radio region on page 41
- 5.13 Switching between high and low transmit power on page 41
- 5.14 GNSS (GPS) set up on page 42





5.1 Raymic handset controls

The Raymic handset's controls are shown below.

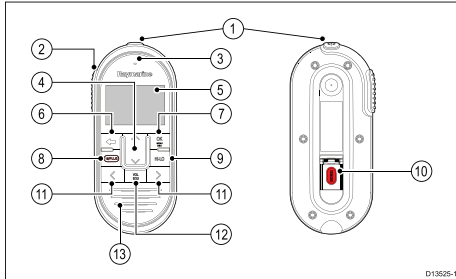

1. **Power** — Press to power the handset on. Press and hold for 3 seconds to power the handset off. Momentary press to access the shortcut list.
2. **PTT(Push to Talk)** — Press and hold to send a voice message. Release to return to receive mode.

Note: The maximum transmit time is limited to 5 minutes to prevent un-intentional transmissions from occupying the VHF channel.

3. **Microphone location**
4. **Volume Up and Volume Down** — Press to adjust volume or squelch up or down.
5. **LCD screen**
6. **Back** — Move back through menu options.
7. **OK / menu button** — Press button to access menu / DSC functions and to confirm selections.
8. **16 / +** — When powered on press to switch between priority channels.
9. **HI/LO** — Press to switch between High (25 W) and low (1 W) transmit power.
10. **DISTRESS** — Lift up the spring loaded cover and press this button to make a DSC distress call.

34

11. **Channel Up and Channel Down** — Changes the channel up or down.
12. **VOL/SQ** — Press button to switch between volume and squelch control.
13. **Built-in speaker**

5.2 Powering the Base station

The Base station automatically powers up when connected to a suitable power supply.

The Base station is powered down by unplugging from the power supply or, if applicable, by tripping it's circuit breaker.

Powering the handset

With the Base station powered On and the Handset connected:

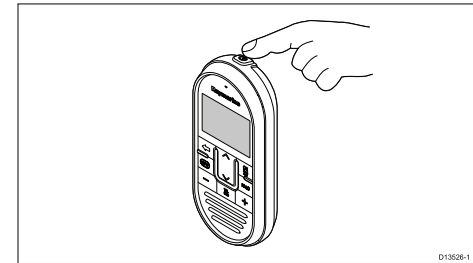

1. Press the **Power** button, located on the top of the Handset.
The Handset will power on.
2. To power off the Handset, press and hold the **Power** button for approximately 3 seconds, until the screen turns off.





5.3 Homescreen overview

The information below describes the on-screen characters and symbols which the radio displays on the main screen and what they mean.

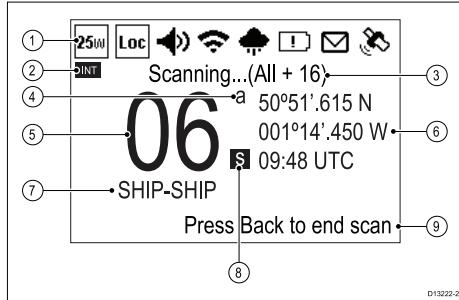

- Status bar** — The status bar displays symbols which indicate the current status of the unit.
 - Frequency band** — Indicates which channel frequency band is in use:
 - USA — United States of America
 - INT — International
 - CAN — Canada
 - WX — Weather
- Note:** Special licensing is required to receive USA and Canadian channel sets.
- Status text** — Indicates the current radio mode e.g.: ATIS Mode active, Weather Alert, Scan mode etc.
 - Channel suffix**
 - **a** — Indicates that the current US or Canadian channel is simplex. This channel uses the transmit frequency of the International channel for transmitting and receiving. If a channel is simplex in all 3 frequency bands (e.g. channel 06, the channel does not require the **a** suffix.
 - **b** — Indicates that the channel is a receive only channel. Used for Canadian channels only.

- Channel** — Indicates the current channel number.
- Location / Time** or **Location / COG/SOG** — Depending on selection displays Location coordinates and current time or Location coordinates and current COG and SOG.
- Channel Name** — Indicates the name of the current channel.
- Channel type** — Indicates the type of channel:
 - **s** = Simplex — Simplex channels transmit and receive on the same frequency.
 - **d** = Duplex — Duplex channels use separate frequencies to transmit and receive.
- Optional text** — Provides extra user guidance.

Status bar symbols



The status bar is used to display icons that indicate the radio's status.

Symbol	Name	Description
	Low power	Indicates the radio transmitters is in low power (1 watt) or high power (25 watt) mode
	High power	
	Local	Indicates the radio is in local reception mode, which decreases receiver sensitivity in high traffic areas to decrease unwanted reception

Symbol	Name	Description
	Fog horn	Indicates that the radio is in Fog horn mode.
	Transmit	Indicates the radio is currently transmitting (e.g. the PTT button is being pressed.)
	Receive	Indicates the radio is currently receiving a transmission
	Weather	Indicates that the weather alerts mode is activated.
	Power supply voltage too low	Indicates the power supply to the radio is below the specified operating voltage
	Power supply voltage too high	Indicates the power supply to the radio is above the specified operating voltage





Symbol	Name	Description
	DSC	Indicates that a DSC call has been received
	GPS Fix	Indicates if the radio has a GPS/GNSS fix.



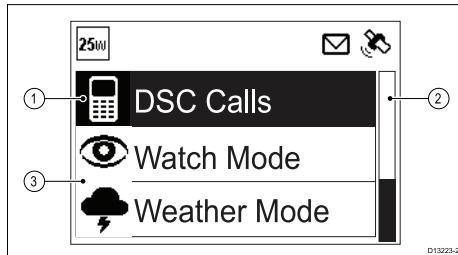

Main menu overview





The main menu is accessed by Pressing the **OK** button from the **Homescreen**.



1. Currently selected menu item
2. Scroll bar
3. Menu items

The main menu includes the following items:

Symbol	Name	Sub-options
	* DSC Calls	<ul style="list-style-type: none"> • Individual call • Distress call • Position request • Group call • All ships call • Phonebook • Call logs • Test call • DSC set-up
	* Watch Mode	<ul style="list-style-type: none"> • Dual watch • Triple watch • 2nd priority channel
	* Weather Mode	<ul style="list-style-type: none"> • Weather Homescreen
	* Scan Mode	<ul style="list-style-type: none"> • All channels • All channels + 16 • Saved channels • Saved channels + 16 • Edit saved channels

Symbol	Name	Sub-options
	** Hail/Fog/Intercom	<ul style="list-style-type: none"> • Hailer • Fog horn • Intercom
	** Hailer/Fog horn	<ul style="list-style-type: none"> • Hailer • Fog horn
	** Intercom	<ul style="list-style-type: none"> • Intercom
	Set-up	<ul style="list-style-type: none"> • Display set-up • Language • Units • Power output • Sensitivity • Key beep • Channel set-up • Weather alerts • GPS set-up • DSC set-up • AIS • Network output • ATIS set-up • Maintenance





Note:

* Menu items not available when radio has ATIS enabled or if the radio has been pre-programmed in MARCOM-C mode.

** The menu name and sub-options depend on the peripheral devices connected to the radio.

5.4 Shortcut list

Pressing the **Power** button once while the radio is switched on will open the **Shortcuts list**. The Shortcuts list can be used to adjust the brightness, contrast and access frequently used functions.

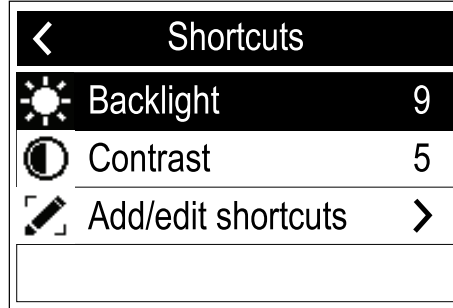

Frequently used functions can be added by selecting **Add/edit shortcuts**.

Adjusting Brightness and Contrast

The LCD Brightness (Backlight) and Contrast can be adjusted using the Shortcuts list.

From any screen:

1. Press the **Power** button.
2. Select **Backlight** or **Contrast**.
3. Use the **Rotary knob** to adjust the Backlight or Contrast to the desired level.
4. Press the **Back** button to return to the previous screen.

The Backlight and Contrast settings can also be accessed from the Display set-up menu: **Menu > Set-up > Display set-up** .

5.5 Shared Brightness

You can set up Shared Brightness groups which enables simultaneous brightness adjustment the all units that are part of the same group.

The following products are compatible with Shared Brightness:

- LightHouse™ or LightHouse™ 2 powered MFDs.
- SeaTalkng® Instrument displays and Pilot controllers.
- SeaTalkng® VHF DSC Radios.

Any adjustments to the Shared Brightness level will be reflected on all units assigned to the same group.



Multiple brightness groups can be configured. These groups could be used to reflect the physical location of units on your vessel. For example, the units at your helm can be set to one group, and the units on the flybridge can be set to a different group.

Shared Brightness requires:

- all units to be compatible with the Shared Brightness function (see list of compatible units above).





- the **Share brightness** setting set to On for all units in the brightness group.
- units to be assigned to Network Groups.
- all the displays in that group to be synchronized.

Enabling Shared Brightness

From the **Display Set-up** menu: (**Menu > Set-up > Display Set-up**).

1. Select **Shared Brightness**.
2. Select **Shared Brightness** again to enable Shared Brightness.

If Shared Brightness is already enabled then selecting this menu item will disable Shared Brightness.

3. Select **Group**.
4. Select the group that you want to assign the radio to.

Adjusting the Brightness setting will now change the brightness of all products assigned to that group.

5.6 Initial startup

Unless your radio has been pre-programmed; the first time you power-up your radio you will be requested to select certain options. With the exception of your MMSI and ATIS ID, you will also be requested to enter these options after a factory reset.

After acknowledging the startup screen, unless previously set you will be prompted to make the following selections:

1. **Language selection** — See [5.7 Selecting a language](#) for available languages.
2. **Turn on AIS reception (Ray70 and Ray91 only)** — Enables the built-in AIS receiver. This step is only applicable to radios with a built-in AIS receiver. See [5.8 Switching on the AIS receiver](#) for more information.
3. **Select network type** — Selects which connection to transmit AIS and DSC information on, to connected equipment. This step is only applicable if the AIS receiver was turned on in the previous step. See [5.9 Selecting a network type](#) for available options.
4. **Enter MMSI number** — Required to enable DSC functions. This option is not required after a factory reset, or if the radio has been pre-programmed in MARCOM-C mode, or has ATIS enabled. See [5.10 Entering an MMSI number](#) for more information. If not already selected you will also be prompted to select your network type.
5. **Enter ATIS ID** — Required when the radio will be used in the inland waterways of Europe. This step is only applicable if the radio has been pre-programmed in MARCOM-C mode. See [5.11 Entering an ATIS ID](#) for more information.
6. **Frequency band selection** — Sets the relevant channels for your region. This step is not applicable if the radio has been pre-programmed in MARCOM-C mode. See [5.12 Changing the radio region](#) for more information.

5.7 Selecting a language

The language the radio uses can be changed.

From the Main menu:

1. Select **Set-up**.
2. Select **Language**.

The languages available are:

- **English (default)** — English
- **Español** — Spanish
- **Français** — French
- **Deutsch** — German
- **Italiano** — Italian

3. Select the language that you want the radio to be set to.

The User interface language is changed to the selected language.





5.8 Switching on the AIS receiver

If your radio includes a built-in AIS receiver then it can be enabled and disabled as follows:

From the Main menu:

1. Select **Set-up**.
2. Select **AIS**.
3. Select **On** to switch the receiver on, or select **Off** to switch the receiver off.

5.9 Selecting a network type

When connecting your radio to other devices it is important to ensure you select the network connection and type that you want data to be transmitted over.

From the Main menu:

1. Select **Set-up**.
2. Select **Network output**.

The following network types are available:

- NMEA 2000 (default)
- 0183 High speed
- 0183 Std speed

3. Select the network type relevant to the devices connected to your radio. If your radio is not connected to any other devices any option can be selected.

Selecting **0183 Std speed** will disable the built-in AIS receiver, where applicable.

The **Network output** setting determines the baud rate of the NMEA 0183 input:

Network output setting	NMEA 0183 input baud rate
NMEA 2000	Standard speed (4,800)
NMEA 0183 High Speed	High speed (38,400)
NMEA 0183 Standard Speed	Standard speed (4,800)

5.10 Entering your MMSI number

To program your radio with your MMSI number follow the steps below.

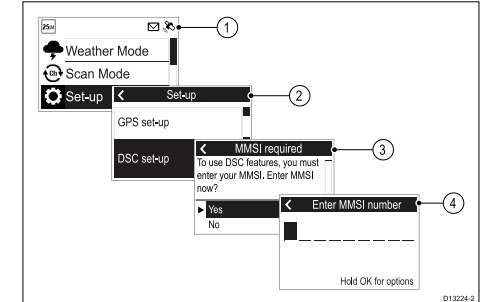

From the Set-up menu: (**Menu > Set-up**)

1. Select **DSC set-up**.
2. Select **MMSI**.

The **MMSI required** message will be displayed if no MMSI number has been set.

3. Select **Yes**.
4. Use the **Rotary knob** to cycle through the available numbers and press **OK** to confirm each number and move to the next digit.

You should only enter the unique 9 digit MMSI number provided by your licensing authority.

MMSI numbers starting with a '0' are only used for groups and coast stations. If you enter a '0' as the first digit the radio will assume you are entering a coast station MMSI and automatically assign a '0' as the second digit; this is to ensure a group MMSI is not entered as the radio's unique MMSI.

5. Press the **Back** button at any time to edit digits you have already entered.
6. Press and hold the **OK** button to display options to **Move cursor** back and forward through the digits.





7. When the final digit is confirmed select **DONE**.

Example

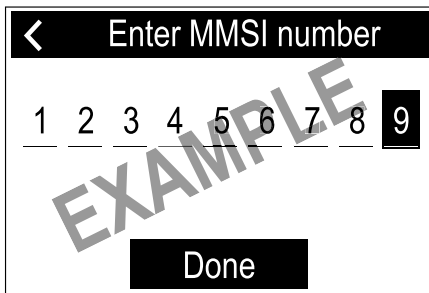

8. The MMSI is displayed onscreen, check that it is correct, then:

- i. Select **Yes – Save**, or
- ii. if the number entered is not correct select **No – Retry**.

Caution: MMSI and ATIS ID entry

You can only enter the MMSI number and ATIS ID once!

If you store an incorrect MMSI number or ATIS ID in your product, it will have to be reset by an authorized **Raymarine®** dealer.

5.11 Entering your ATIS ID

A unique ATIS ID must be entered before ATIS mode can be enabled.

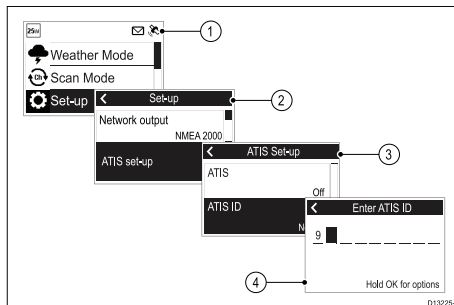

From the Main menu.

1. Select **Set-up**.
2. Select **ATIS set-up**.
3. Select **ATIS ID**.

***Not set** will be displayed if no ATIS ID has been set. The first digit is set to a '9' and cannot be changed, this is because all ATIS IDs start with a '9'.*

As most ATIS IDs consist of a '9' followed by your 9 digit MMSI number; if your radio already has an MMSI number the ATIS ID will be pre-filled in this format.

4. If the ATIS ID has been pre-filled, check it carefully against your issued ATIS ID.
5. To enter your ATIS ID manually, use the **Rotary knob** to cycle through the available numbers and press **OK** to confirm each number and move to the next digit.

You should only enter the unique 10 digit ATIS ID provided by your licensing authority.

6. Press the **Back** button at any time to edit digits you have already entered.
7. Press and hold the **OK** button to display options to **Move cursor** back and forward through the digits.

8. When the final digit is confirmed select **DONE**.

Example

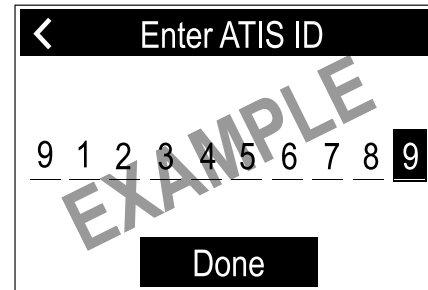

9. The ATIS ID is displayed onscreen, check that it is correct, then:

- i. Select **Yes – Save**, or
- ii. if the number entered is not correct select **No – Retry**.

Caution: MMSI and ATIS ID entry

You can only enter the MMSI number and ATIS ID once!

If you store an incorrect MMSI number or ATIS ID in your product, it will have to be reset by an authorized **Raymarine®** dealer.

Enabling and disabling ATIS mode

ATIS is a European system used on some inland waterways. A unique ATIS ID must be entered to use ATIS mode.

With ATIS mode enabled the radio's region will be fixed to the INT (international) frequency band and the following functions are disabled:

- DSC functions
- Watch Mode
- Scan Mode





- High/low power is restricted on certain channels

From the Main menu.

1. Select **Set-up**.
2. Select **ATIS set-up**.
3. Select **ATIS**.

If no ATIS ID has been set then you will be requested to enter one before ATIS mode is enabled refer to [5.11 Entering your ATIS ID](#) for instructions.

4. If an ATIS ID has already been set then select **On** to enable ATIS mode or **Off** to disable ATIS mode.

5.12 Changing the radio region

Prior to using the radio you must set the Frequency band to the region your radio will be used in.

From the Main menu:

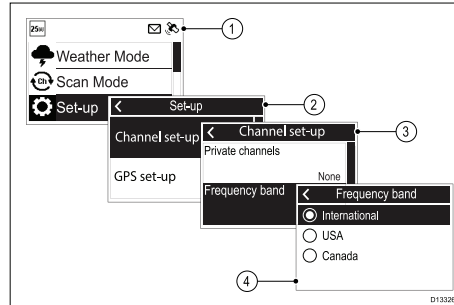

1. Select **Set-up**.
2. Select **Channel set-up**.
3. Select **Frequency band**.
4. Select the relevant region from the list.

The available options are:

- **International**
- **USA**
- **Canada**

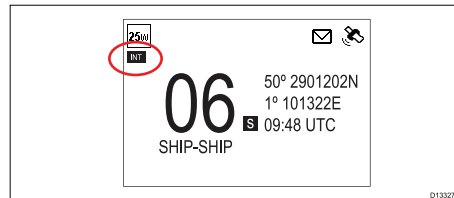

An icon is displayed on the Homescreen that identifies which region has been set.

5.13 Switching between high and low transmit power

You can switch between high (25 W) and low (1 W) transmit power using the HI/LO button on the Fisticmic.

The transmit power can also be changed from the **Set-up** menu: **Menu > Set-up**

1. Select **Power output**.
2. Select **Low** for 1 W transmit power, or
3. Select **High** for 25 W transmit power.





5.14 GNSS (GPS) set up

If your radio includes an internal GNSS (GPS) receiver or if your radio is connected to a receiver over NMEA 0183 or SeaTalkng®, the radio can display relevant position information.

The following information can be displayed:

- latitude
- longitude
- UTC time
- COG and SOG

When position data is available the satellite icon is displayed onscreen.

If no position data is available then the latitude, longitude and time can be entered manually so that it can be included in DSC distress transmissions.

Position data received from other vessels can be displayed on a connected Raymarine® multifunction display.

Enabling and disabling the internal GNSS (GPS)

From the **GPS set-up** menu: **Menu > Set-up > GPS set-up**

1. Select **Internal GPS**.

Selecting **Internal GPS** will switch the internal GNSS (GPS) receiver On and Off.

No GPS position data

If no GPS data is available or GPS data becomes unavailable; after 10 minutes an audible warning is sounded, the GPS icon flashes and the **No position data** message is displayed.

Once the warning has been acknowledged the GPS icon will continue to flash. The **No position data** warning is repeated every 4 hours if position data is still unavailable, has not been entered manually or has been entered manually but over 23.5 hours ago.

If position data has been entered manually the display alternates between displaying the manual position and time and the **Manual Position** message. if the manually

entered position has not been updated in the last 4 hours the GPS icon flashes and an audible warning is sounded. This warning will be repeated every 4 hours until position is manually updated or GPS position data becomes available.

Where no position data is available or has not been manually updated for 23.5 hours then position data will change to '9's and time will change to '8's.

Entering position manually

If GPS position data is not available it can be entered manually.

From the **GPS set-up** menu: **Menu > Set-up > GPS set-up**.

1. Select **Set manual position**.

The Manual position screen requires you to input latitude, longitude and UTC time.

2. Use the **Rotary knob** to cycle through the available numbers and press **OK** to confirm each number and move to the next digit.
3. When the relevant information has been entered select **OK** to confirm the details.

Selecting GPS information to display

You can change the GPS data that is displayed on the Homescreen.

From the **GPS set-up** menu: **Menu > Set-up > GPS set-up**.

1. Select **Homescreen display**.
2. Select the required option:

- *Location & time*
- *Location & COG/SOG*

The **Homescreen display** option is also available from the **Display set-up** menu

Setting time format and offset

You can change the Format and Offset that is applied to the time displayed onscreen.

From the **Units** menu: **Menu > Set-up > Units**.

1. Select **Time format**.
2. Select the desired format:
 - 12 hour
 - 24 Hour (default)
3. Select **Time offset**.
4. Adjust the offset to the desired value using the **Rotary knob** or the **Channel Up** and **Channel Down** buttons.
5. Select **OK** to confirm the selection.





Chapter 6: Digital selective calling (DSC)

Chapter contents

- [6.1 Digital Selective Calling \(DSC\) on page 44](#)
- [6.2 Distress calls on page 45](#)
- [6.3 Urgency calls on page 47](#)
- [6.4 Safety calls on page 48](#)
- [6.5 Individual \(routine\) calls on page 48](#)
- [6.6 Group calls on page 49](#)
- [6.7 Position requests on page 49](#)
- [6.8 Phonebook on page 50](#)
- [6.9 Call logs on page 51](#)
- [6.10 Test calls on page 51](#)
- [6.11 DSC set-up menu options on page 52](#)





6.1 Digital Selective Calling (DSC)

Traditional VHF radio systems require users to listen until someone speaks, and then determine whether the call is for them. DSC ensures that calls are received by alerting or announcing the intended recipient(s) first so they are ready to listen to the subsequent message on the relevant channel.

DSC is part of the Global Maritime Distress and Safety System (GMDSS), a maritime communications system for emergency and distress messages and all types of routine communications such as ship-to-ship or ship-to-shore.

DSC is a digital signalling system, which operates on VHF channel 70. DSC calls include other data such as your vessel's identification number, purpose of the call, your position and the channel you want to speak on.

DSC calls can be divided into 4 categories and are prioritized as shown below:

1. Distress
2. Urgency
3. Safety
4. Routine

Distress

A Distress call should only be used when there is imminent danger to a vehicle or person that requires immediate assistance.

When making a distress call the following information is transmitted to all stations within range:

- Vessel MMSI number.
- Vessel position (must be input manually if no GPS position data is available).
- Local time (must be input manually if no GPS position data is available).
- Nature of the distress (when designated).
- Transmission frequency.

The call is automatically repeated at approximately 4 minute intervals until it is acknowledged either by a coast radio station (CRS) or a vessel within radio range. Distress calls must be followed by a MAYDAY call on priority channel 16.

Urgency

An urgency call should be used when there is danger to a vehicle or person that does not require immediate assistance.

When making an urgency call the following information is transmitted to all stations within range:

- Vessel MMSI number.
- Vessel position (must be input manually if no GPS position data is available).
- Local time (must be input manually if no GPS position data is available).
- Transmission frequency.

Once an urgency call is sent it must be followed with a PAN PAN voice message on channel 16 and include the necessary details.

Safety

A safety call should be used when there is an important navigational warning or meteorological forecast/broadcast. Safety alerts can also be used for communications during search and rescue operations.

When making a safety call the following information is transmitted to all stations within range:

- Vessel MMSI number.
- Vessel position (must be input manually if no GPS position data is available).
- Local time (must be input manually if no GPS position data is available).
- Transmission frequency.

Once a safety call is sent it must be followed with a SECURITE voice message on channel 16 and include the necessary details.

Routine calls

Routine calls are used for contacting other vessels, marinas, or shore stations.

Routine calls are made on channel 70 using the dedicated Maritime Mobile Service Identity (MMSI) number of the station to be contacted, selecting a VHF working channel and sending the call. Both radios automatically switch to the chosen channel for conversation.

Routine calls can also be made to groups — When groups of ships need the same information (yacht races, club rallies etc.) a special group-call identity can be used to enable restricted broadcast calls.

Note: To transmit precise positions, the radio must be interfaced to a GPS receiver. Otherwise, regular manual position updating is required.





6.2 Distress calls

Making a designated distress call

When making a Distress call you can specify the nature of the distress, if GPS data is not available you must also specify your coordinates.

Note: Your radio must have an MMSI number saved before DSC functions can be used.

From the Distress call menu: **Menu > DSC Calls > Distress calls**

1. Select a distress type from the list.

- Undesignated
- Fire
- Flooding
- Collision
- Grounding
- Listing
- Sinking
- Adrift
- Abandoning
- Piracy
- Man overboard

If your radio has a GPS fix then the distress type and coordinates are displayed, otherwise you will be prompted to enter your position coordinates.

2. If prompted, enter your position coordinates and local time using the **Rotary knob** or the **Channel Up** and **Channel Down** buttons to enter the relevant details.
3. When complete press the **OK** button.
4. Follow the steps for Making a Distress Call to transmit the distress alert.

Digital selective calling (DSC)

Making a distress call

In an emergency you can use your unit to make an automatic DSC distress call.

With the spring loaded cover open:

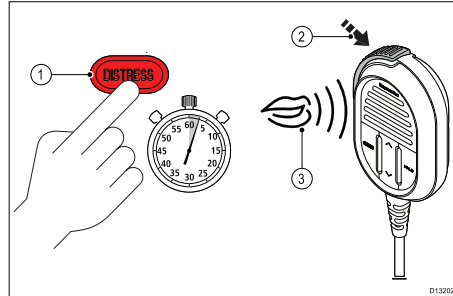

1. Press and hold the **DISTRESS** button for 3 seconds.

*Once the **DISTRESS** button is pressed a 3 second count down will begin, when the count down reaches zero the DSC distress call is transmitted.*

The distress call is repeated automatically until it is acknowledged.

2. Press and hold the **PTT** button, then slowly and clearly speak the details of the distress in the following format:

MAYDAY, MAYDAY, MAYDAY

This is <state name of vessel 3 times>

MAYDAY <state name of vessel 1 time>

My position is <state latitude and longitude, or true bearing and distance from a known point.>

I am <state nature of distress e.g. sinking, on fire etc.>

I have <state number of persons on board and any other information — drifting, flares fired etc.>

I REQUIRE IMMEDIATE ASSISTANCE

OVER

3. Release the **PTT** button.

Making a Mayday call

In an emergency you can use your unit to make a Mayday call.

1. Press the **16 PLUS** button.
2. Press and hold the **PTT** button.
3. Slowly and clearly speak the details of the distress:

MAYDAY, MAYDAY, MAYDAY

This is <state name of vessel 3 times>

MAYDAY <state name of vessel 1 time>

My position is <state latitude and longitude, or true bearing and distance from a known point.>

I am <state nature of distress e.g. sinking, on fire etc.>

I have <state number of persons on board and any other information — drifting, flares fired etc.>

I REQUIRE IMMEDIATE ASSISTANCE

OVER

4. Release the **PTT** button.
5. If an acknowledgement is not received then repeat steps 2 to 4 above.

Cancelling a distress call before transmission

To cancel a distress call before it is transmitted follow the steps below:

1. Release the **DISTRESS** button before the countdown timer completes.

When the button is released you will be returned to normal operation.



Cancelling a distress call after transmission

A distress call can be cancelled after it has been transmitted.

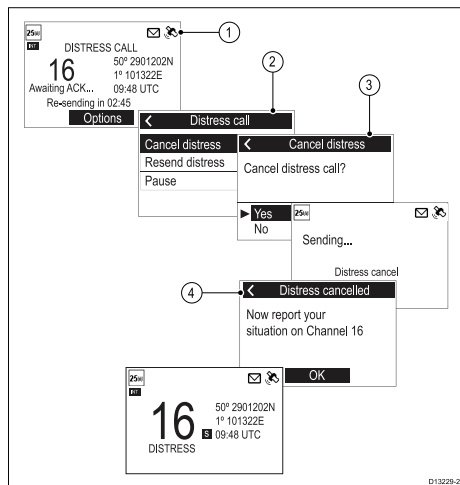

1. Select **Options**.
2. Select **Cancel distress**.
3. Select **Yes** to confirm cancellation.
4. Select **OK**.
5. Press and hold the **PTT** button and make a broadcast to all stations giving your vessel's name, call sign and MMSI number and cancel the false distress alert

Example: "All, Stations, All Stations, All Stations. This is <NAME>, <CALL SIGN>, <MMSI ID>, <POSITION>."

Cancel my distress alert of <DATE>, <TIME>, <NAME>, <CALL SIGN>"

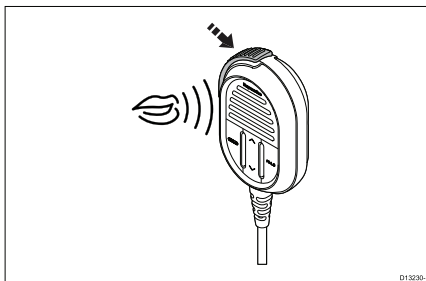

6. Repeat the broadcast described in step 5.

Receiving a distress call

It is expected that only a Coast Radio Station (CRS) will acknowledge DSC distress calls and will act as the coordinator for the rescue operation.

When a distress call is received an alarm is sounded at full volume and the LCD displays information relating to the distress.

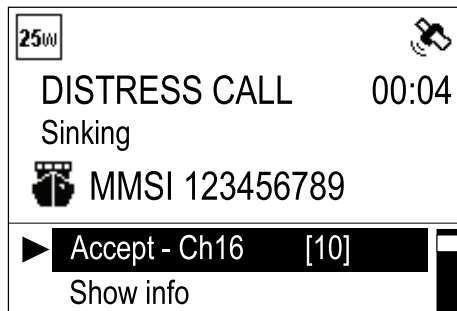

If the **Auto channel change** function is enabled; 10 seconds after receipt of a distress call the radio will automatically re-tune to channel 16. Otherwise the user is prompted to change channel manually.

The details of the distress call are recorded in the distress log and the envelope icon will flash to let you know a message has been received. When connected to a **Raymarine**® multifunction display (**MFD**) the position data from the distress call can also be displayed in the Chart application.

When the received distress call is acknowledged by the CRS or by another station the radio will resume normal operation.

Ignoring a distress call

You can ignore a distress call by muting the alarm and cancelling the distress call screen.

If your radio is already tuned to the priority channel then the **Ignore** option will not be available.

With an incoming distress call displayed.

1. Select **Ignore** from the options displayed.
- Normal operation is resumed.

Acknowledging a distress call

Distress calls must only be acknowledged if the call continues without acknowledgement from a CRS, you are close enough to the distressed vessel to be of assistance and are prepared to relay the distress to a CRS by any means possible. Class D DSC radios are forbidden from automatically acknowledging distress calls. Acknowledgement must only be made by voice message on channel 16.

After receiving a distress call that has gone unanswered:

1. Switch to channel 16 to listen for the distress voice message.
2. Wait for the CRS to acknowledge the call.
3. If the distress call is not acknowledged by another station then acknowledge the call as follows:

MAYDAY

(MMSI of the vessel in distress)

Name of vessel in distress <repeated 3 times>

Call sign of the vessel in distress

This is <MMSI of your vessel>, <name of your vessel repeated 3 times> <call sign of your vessel>



RECEIVED MAYDAY

4. You **MUST** then notify the shore authorities by any means possible to relay the distress call.

Manually relaying a distress call

A distress relay should only be sent if: the person or vehicle in distress is unable to transmit the distress call itself, for example red flares sighted at night or the person or vehicle in distress is out of range of a CRS and you have already acknowledged the distress by voice message. You can also relay a received distress relay alert manually if it goes unanswered.

1. Switch to channel 16
2. Slowly and clearly speak the details of the distress:

MAYDAY RELAY, MAYDAY RELAY, MAYDAY RELAY

This is <MMSI of your vessel, name of your vessel repeated 3 times and your call sign>

Received the following MAYDAY from <MMSI of vessel in distress, name of vessel in distress, call sign of vessel in distress>

Message begins

Message received from vessel in distress or details of the distress

Message ends

OVER

Distress relays sent by other stations

When a Coast Station or another vessel, has received, and acknowledged a DSC distress alert it may transmit a distress relay to other vessels in the immediate area.

Distress relays sent from other stations can be received by the radio.

The radio cannot re-send a distress relay automatically. If required you can relay a distress relay message manually.

If a distress relay is sent specifically to the radio then it can be acknowledged, otherwise acknowledgement is not required.

Digital selective calling (DSC)

Acknowledging a distress relay sent to your vessel

If a distress relay is specifically sent to your vessel this will be because the sender deems you to be in a position to assist in the rescue. The distress relay information is displayed onscreen.

When a distress relay is received:

1. Select **Show info** from the options to review the relevant details.
2. If the distress relay was sent individually to you, select **Accept** to send a distress relay acknowledgement.
3. Ensure the radio is tuned to channel 16.

Note: Distress relay calls can only be acknowledged automatically when sent individually to you.

6.3 Urgency calls

Making an urgency call

An urgency call should be used when there is danger to a vehicle or person that does not require immediate assistance. Urgency calls are transmitted to all stations.

From the **All ships call** menu: **Menu > DSC Calls > All ships call**.

1. Select **Urgency**.
2. Select the channel for subsequent communication.

The call is transmitted. Once the call has been successfully transmitted **'Sent'** is displayed onscreen and the channel is changed to the specified channel.

3. Press the **OK** button.
4. Press and hold the **PTT** button and speak the following message:

PAN PAN, PAN PAN, PAN PAN

ALL STATIONS, ALL STATIONS, ALL STATIONS

This is <MMSI of your vessel, name of your vessel repeated 3 times, call sign of your vessel>

Position <Your vessel's position>

Reason for call <State the reason for the call and include all information which will assist in the rescue.

OVER

Receiving an urgency call

When an urgency call is received:

1. Select **Show info** from the options to review relevant call details.
2. Select **Accept** at any time to accept the call.

If auto channel change is turned on then the channel will automatically change after 10 seconds.

The radio is re-tuned to the specified channel.

3. Listen for the urgency call message.



6.4 Safety calls

Making a safety call

Safety calls should be used when there is an important navigational warning or meteorological forecast/broadcast. Safety alerts can also be used for communications during search and rescue operations.

From the **All ships call** menu: **Menu > DSC Calls > All ships call**.

1. Select **Safety**.
2. Select the channel for subsequent communication.
The call is transmitted. Once the call has been successfully transmitted '**Sent**' is displayed onscreen and the channel is changed to the specified channel.
3. Press the **OK** button.
4. Press and hold the **PTT** button and speak the following message:

SECURITE, SECURITE, SECURITE

ALL STATIONS, ALL STATIONS, ALL STATIONS

This is <MMSI of your vessel, name of your vessel repeated 3 times, call sign of your vessel>

Position <Your vessel's position>

Reason for call <state the reason for the safety call>

OUT

Receiving a safety call

When a safety call is received:

1. Select **Show info** from the options to review relevant call details.
2. Select **Accept** at any time to accept the call.

If auto channel change is turned on then the channel will automatically change after 10 seconds.

The radio is re-tuned to the specified channel.

3. Listen for the safety call message.

6.5 Individual (routine) calls

Individual calls can be made to contacts saved in your phonebook or to any station by manually entering an MMSI number.

Note: When calling a coast station there is no need to select a channel for communication.

If a call cannot be accepted then a reason code is displayed.

No Reason	No reason given
Congestion	Congestion at maritime switching centre
Busy	Station Busy
Queue	Queue indication
Barred	Station barred
No operator	No operator available
Unavailable	Operator temporarily unavailable
Disable	Equipment disabled
Unable Ch	Unable to use proposed channel
Unable mode	Unable to use proposed mode

Making a routine DSC call

From the **Individual Call** menu: **Menu > DSC Calls > Individual Call**.

1. Select **Phonebook** to make a routine call to a contact saved in your Phonebook, or
2. Select **Recent Calls** to make a routine call to a contact that you have called recently, or
3. Select **Enter MMSI** to manually enter the MMSI number of the station you want to contact.
4. Select a contact or enter an MMSI manually and press the **OK** button.
5. Select the Channel you want to transmit the call on.

If the MMSI is a CSR then the radio will automatically tune to the correct Channel. The radio will wait for an acknowledgement to be received.

6. If an acknowledgement is received, press the **OK** button.
7. Press and hold the **PTT** button and speak your message.
8. Release the **PTT** button when you have completed your message.

Receiving an individual (routine) call

With an incoming individual call displayed:

1. Select **Show info** from the options to review relevant call details.
2. Select **Reply on Ch ##** at any time to accept the call.

If auto channel change is turned on then the channel will automatically change after 10 seconds.

The radio is re-tuned to the specified channel.

3. To reject the call, select **Reject**.
4. If you rejected the call, select a reason for the rejection from the list.

Confirmation of the acceptance or rejection of the call is displayed. If you have accepted the call then the radio will re-tune to the requested channel.





6.6 Group calls

Group calls can be made to groups of vessels sharing the same Group MMSI numbers.

Group calls are made by selecting a saved group contact from the **Phonebook** or by entering the Group MMSI number for the group you want to call.

Making a group call

From the **Group Call** menu: **Menu > DSC Calls > Group Call**.

1. Select **Phonebook** to make a call to a group saved in your Phonebook, or
2. Select **Recent Calls** to make a call to a group that you have called recently, or
3. Select **Enter MMSI** to manually enter the MMSI number of the group you want to contact.
4. Select a group or enter an MMSI manually and press the **OK** button.
5. Select the Channel you want to transmit the call on.

The radio will wait for an acknowledgement to be received.

6. If an acknowledgement is received, press the **OK** button.
7. Press and hold the **PTT** button and speak your message.
8. Release the **PTT** button when you have completed your message.

Receiving a group call

Note: To receive a call made to a Group, the Group's MMSI number must be saved in your phonebook.

With an incoming group call displayed:

1. Select **Show info** from the options to review relevant call details.
2. Select **Reply on Ch ##** at any time to accept the call.

Digital selective calling (DSC)

If auto channel change is turned on then the channel will automatically change after 10 seconds.

The radio is re-tuned to the specified channel.

3. To reject the call, select **Reject**.
4. If you rejected the call, select a reason for the rejection from the list.

Confirmation of the acceptance or rejection of the call is displayed. If you have accepted the call then the radio will re-tune to the requested channel.

6.7 Position requests

The radio can request position information from any station capable of responding to the request.

Position requests can be sent to any contact stored in the **Phonebook** or by manually inputting the station's MMSI number.

When connected to a **Raymarine**® multifunction display the position data from the request can also be display in the Chart application.

Making a position request

You can request the position of another station.

From the **Position Request** menu: **Menu > DSC Calls > Position Request**.

1. Select **Phonebook** to request the position of a contact saved in your Phonebook, or
2. Select **Recent Calls** to request the position of a contact that you have called recently, or
3. Select **Enter MMSI** to manually enter the MMSI number of the station that you want to request the position of.
4. Select a contact or enter an MMSI manually and press the **OK** button.

The position request is sent. When a response is received the position of the contact is displayed.

Responding to a position request

With a Position request displayed:

1. Select **Send position** to respond with your current location, or
2. Select **Cancel** to ignore the request.
3. If the position reply is set to manual then select **SEND** to send the position report.
4. Select **OK** to resume normal operation.

If the **Position requests** setting, found in the **GPS set-up** menu is set to **Auto accept** then the response is sent automatically.





Setting automatic response to position requests

You can configure your radio to respond to incoming position requests automatically.

From the **DSC set-up** menu: **Menu > Set-up > DSC set-up**

1. Select **Position requests** to switch between Manual accept (default) and Auto accept.

6.8 Phonebook

The phonebook can be used to save up to 100 contacts.

You can add, edit and delete contacts stored in the phonebook.

Adding a phonebook entry

You can save contacts in the phonebook by entering their MMSI and assigning a name to the contact.

From the **DSC Calls** menu: **Menu > DSC Calls**.

1. Select **Phonebook**.
2. Select **Add new**.
3. Select the type of contact.
 - Vessel
 - Group
 - Coast station
4. Use the **Rotary knob** to cycle through the available numbers and press **OK** to confirm and move to the next digit.
5. Press the **OK** button to confirm the MMSI.
6. Use the **Rotary knob** to cycle through the available characters and press **OK** to confirm and move to the next character.

The maximum length for contact names is 10 characters.

7. If the Contact name is less than 10 characters, press and hold the **OK** button and select **Save**.
8. Press the **Back** button at any time to edit characters you have already entered.
9. Press and hold the **OK** button and select **Move cursor** to edit an existing character.
10. When complete press the **OK** button to return to the Phonebook.

Editing a phonebook entry

From the **DSC Calls** menu: **Menu > DSC Calls**.

1. Select **Phonebook**.
2. Select the contact you want to edit.
3. Select **Edit name** or **Edit MMSI**
The contact's MMSI or name is displayed.
4. Use the **Rotary knob** to change a character.
5. Press the **OK** button to confirm each character and move to the next.
6. When you have completed your changes press the **OK** button again to save the changes.

Deleting a phonebook entry

From the **DSC Calls** menu: **Menu > DSC Calls**.

1. Select **Phonebook**.
2. Select the contact you want to edit.
3. Select **Delete**.
4. Select **Yes**.

The contact is deleted.





6.9 Call logs

All DSC calls are logged.

The following call types are recorded in call logs:

- distress
- distress relay
- distress acknowledgements
- sent position requests
- received position requests
- group calls
- all ship calls
- individual routine calls

The details below are recorded for each call:

- MMSI number(s) (If a call is relayed up to 3 MMSI numbers can be recorded.)
- type of call
- date and time of call
- latitude and longitude (if sent with the call)
- nature of distress (specified distress calls only)

If the call was received from a contact in the phonebook then the contact name is displayed, otherwise the MMSI number is displayed.

Accessing the call logs

Follow the steps below to access the call logs.

From the **DSC Calls** menu: **Menu > DSC Calls**.

1. Select **Call logs**.
2. Select the log you want to view:
 - Unread
 - Distress calls
 - Non-distress calls
 - Outgoing calls

Digital selective calling (DSC)

- Position log
3. Select a call and press the **OK** button to view details.
 4. Select **Options** to view available options.
 - **Call Back** — return a received call.
 - **Resend** — only available in the outgoing call log.
 - **Call** — available in the position log.
 - **Send position** — available in the position log.
 - **Request position** — available for individual and distress calls.
 - **Save to Phonebook** — available for received and outgoing calls to new contacts.
 - **Send ACK** — available for unacknowledged individual received calls.
 - **Delete** — deletes the log entry.

6.10 Test calls

A Test Call feature is available for the purposes of testing your DSC VHF radio for correct operation.

There are 2 types of test call:

- Test call to the US Coast Guard automated response test call service (MMSI: **003669999**). This type of test call will receive an automated response (acknowledgement).
- Test call to another vessel that has a radio that supports the test call feature. Your radio will automatically acknowledge test calls received from other radios.

For radios that do NOT support the test call feature, correct radio operation can be tested by making an individual call on channel 70 to another DSC VHF radio.

Raymarine recommends that once you've successfully placed a test call you add the test call MMSI to your radio's phonebook for easy retrieval for future test calls. For information on how to add an MMSI to your radio's phonebook, refer to the radio's user documentation.

Note: Individual calls (that is, NOT a test call) to the US Coast Guard 003669999 MMSI will NOT receive an automated response.

Note: The US Coast Guard automated response test call service is only available in the United States and its coastal waters.

Making a test call

From the **Test call** menu: **Menu > DSC Calls > Test call**.

1. Select **Phonebook** to make a test call to a contact saved in your Phonebook, or
2. Select **Recent Calls** to make a test call to a contact that you have called recently, or
3. Select **Enter MMSI** to manually enter the MMSI number of the station you want to send a test call.
4. Select a contact or enter an MMSI manually and press the **OK** button.
The test call is sent.





5. If you called the US Coast Guard automated response test call MMSI (003669999), wait for an acknowledgement. If you made a test call to another vessel with a test call capable radio, your radio will wait for a response.

When an acknowledgement is received, an audible alarm is sounded and the message (envelope) icon is displayed.

Receiving a test call

Your radio will automatically acknowledge received test calls from other stations

When a test call is received a notification is displayed to alert you that a test call has been received and automatically acknowledged.

6.11 DSC set-up menu options

The **DSC set-up** menu options can be accessed from the following menus:

- **Menu > DSC Calls > DSC set-up**
- **Menu > Set-up > DSC set-up**

Menu item	Description	Options
MMSI	To enable the DSC functions on your radio you must enter your unique MMSI number.	
Auto channel change	When automatic channel change is turned on the radio will automatically re-tune after 10 seconds to the requested channel when DSC calls are received.	<ul style="list-style-type: none"> • On (default) • Off
Position requests	With Position requests set to Auto accept the radio will automatically send out position details when a position request is received.	<ul style="list-style-type: none"> • Auto accept (default) • Manual accept





Chapter 7: VHF operations

Chapter contents

- [7.1 Watch modes on page 54](#)
- [7.2 Scan Mode on page 54](#)
- [7.3 Priority channels on page 54](#)
- [7.4 Sensitivity on page 55](#)
- [7.5 Private channels on page 55](#)
- [7.6 Automatic Transmitter Identification System \(ATIS\) and Marcom-C mode on page 55](#)
- [7.7 AIS receiver on page 56](#)
- [7.8 Set-up menu options on page 57](#)





7.1 Watch modes

Watch mode monitors priority channels and the currently selected channel.

There are 2 types of watch mode; **Dual watch** and **Triple watch** or **Tri watch**.

- **Dual watch** — This mode monitors priority channel 16 and the currently selected channel.
- **Triple watch** or **Tri watch** This mode monitors priority channel 16, the second priority channel (Channel 9 (default)) and the currently selected channel. The second priority channel can also be set to a user defined channel.

When the radio detects a transmission, Watch mode is suspended until the transmission ends; watch mode will then recommence.

Using watch modes

From the **Watch Mode** menu: **Menu > Watch Mode**.

1. Select **Dual Watch** or **Triple Watch** as required.
The radio is now in Watch mode.
2. Select **2nd priority channel** to select a different second priority channel for **Triple Watch**.
3. During Watch mode, press the **Back** button at any time to end the Watch mode and resume normal operation.

7.2 Scan Mode

Scan mode enables automatic searching for channels that are currently broadcasting.

Scan mode will search through available channels and stop when it finds a channel that is currently broadcasting. If the broadcast stops or is lost for more than 5 seconds then the scan will resume.

Channels can be temporarily removed from an active scan, and the direction of scan can also be changed. When the scan reaches the last channel in the band the scan cycle is repeated.

The following scans options are available:

- **All Channels** — All channels in the frequency band the radio is set to are scanned in sequence.
- **All Channels + 16** — All channels in the frequency band the radio is set to are scanned, after each channel is scanned priority channel 16 is scanned.
- **Saved Channels** — Only channels saved to the radio's memory are scanned in sequence.
- **Saved Channels + 16** — Only channels saved to the radio's memory are scanned, after each channel is scanned priority channel 16 is scanned.

Note: If the weather alert function is activated, the weather alert channel is included in the scan.

Performing a scan

Scan mode is started from the main menu.

From the **Scan Mode** menu: **Menu > Scan Mode**.

1. Select the relevant Scan mode.
The radio is now in Scan mode.
2. Select **Edit Saved Channels** to select the channels that will be scanned when performing a Saved channel scan.
3. During Scan mode, press the **Back** button at any time to end the Scan mode and resume normal operation.

7.3 Priority channels

Channel 16 is the dedicated priority channel.

The default secondary priority channel is channel 09. The second priority channel can be changed if desired.

Switching between priority channels

1. Press the **16 / +** button to switch between priority channels.

Setting a second priority channel

You can select which channel you want to use as the second priority channel.

From the **Channel set-up** menu: **Menu > Set-up > Channel set-up**.

1. Select **2nd priority channel**.
2. Select the channel that you want to assign as the second priority channel.





7.4 Sensitivity

The sensitivity level of the radio can be set to Local mode or Distant mode.

Local mode decreases the receiver sensitivity in high traffic areas to reduce unwanted reception. When in Local mode the 'Loc' icon is displayed in the status bar.

Distant mode sets the receiver sensitivity to full.

Switching sensitivity modes

You can switch between Local and Distant modes at any time.

From the **Set-up** menu: **Menu > Set-up**.

1. Select **Sensitivity**.

Selecting Sensitivity will switch between Local mode and Distant mode (default).

7.5 Private channels

The radio may be able to receive additional Private channels depending on the country it is used in and whether the appropriate licenses are held.

The following Private channel sets can be selected:

- None
- Belgium
- Denmark (pleasure)
- Denmark (fishing)
- Finland (pleasure)
- Finland (fishing)
- Holland (Netherlands)
- Norway (pleasure)
- Norway (fishing)
- Sweden (pleasure)
- Sweden (fishing)
- UK

Selecting a private channel set

You can select the set of private channels you want to use.

From the **Channel set-up** menu: **Menu > Set-up > Channel set-up**.

1. Select **Private channels**.

The list of private channel sets is displayed:

2. Select the required private channel set.

7.6 Automatic Transmitter Identification System (ATIS) and Marcom-C mode

ATIS is a European system used on some inland waterways.

VHF radios operating in an ATIS region must be programmed with a unique ATIS number; this can be obtained from the relevant licensing authority. The ATIS number is attached as a digital signal at the end of each transmission and identifies you to the relevant authorities who monitor the system.

When operating in ATIS mode, some of the products features are not available:

- Use of DSC functions is not permitted in ATIS regions.
- Watch modes are not permitted in ATIS regions.
- Channel scanning is not permitted in ATIS regions.
- ATIS regulations restrict the transmit power to 1 watt for the following channels: 6, 8, 10, 11, 12, 13, 14, 71, 72, 74 and 77.

You can enable or disable ATIS using the menus (except on Marcom-C configured units).

Marcom-C mode

Marcom-C mode is a restricted radio configuration for VHF operators with a Marcom-C license. This is applicable to radios operated exclusively in European inland waterways using the ATIS system.

A Marcom-C VHF radio has the ATIS permanently enabled. You will not be able to disable ATIS operation. Marcom-C operation is set by the dealer at point of sale. If you wish to enable or disable Marcom-C mode, you must contact your Raymarine dealer.

For further information please contact Raymarine technical support.





Enabling and disabling ATIS mode

ATIS is a European system used on some inland waterways. A unique ATIS ID must be entered to use ATIS mode.

With ATIS mode enabled the radio's region will be fixed to the INT (international) frequency band and the following functions are disabled:

- DSC functions
- Watch Mode
- Scan Mode
- High/low power is restricted on certain channels

From the Main menu.

1. Select **Set-up**.
2. Select **ATIS set-up**.
3. Select **ATIS**.

If no ATIS ID has been set then you will be requested to enter one before ATIS mode is enabled refer to [5.11 Entering your ATIS ID](#) for instructions.

4. If an ATIS ID has already been set then select **On** to enable ATIS mode or **Off** to disable ATIS mode.

7.7 AIS receiver

Depending on variant your radio may have a built-in AIS receiver.

With the built-in AIS receiver switched on AIS information can be sent to a connected Raymarine® MFD using either NMEA 0183 or SeaTalkng®.

Note: If using the built-in AIS receiver and outputting over NMEA 0183, ensure that the baud rate is set to **0183 High speed: Menu > Set-up > Network output** .

Switching AIS on and off

From the **Set-up** menu: **Menu > Set-up**.

1. Select **AIS**.
Selecting AIS will switch the internal AIS receiver On and Off.





7.8 Set-up menu options

The **Set-up** menu options can be accessed from the menu.

Menu	Description	Options
Display set-up	Provides access to the display settings menu	<ul style="list-style-type: none"> • Backlight • Shared brightness • Contrast • Homescreen display
Language	Enables selection of user interface language.	<ul style="list-style-type: none"> • English (default) — English • Español — Spanish • Français — French • Deutsch — German • Italiano — Italian
Units	Provides access to units of measure related settings	<ul style="list-style-type: none"> • Time format • Time offset • Bearing mode • Speed unit
Power output	Enables you to switch the Power output of the radio.	<ul style="list-style-type: none"> • Distant (default) • Local
Sensitivity	Enables you to switch the Sensitivity of the radio.	<ul style="list-style-type: none"> • Low • High (default)
Noise cancelling (Tx)	Enables you to switch the transmission noise cancellation feature On and Off. <div style="border: 1px solid black; padding: 5px; margin-top: 10px;"> <p>Note: Only available on Ray60, Ray70 and Ray90.</p> </div>	<ul style="list-style-type: none"> • On (default) • Off





Menu	Description	Options
Key Beep	Enables adjustment of the beep heard when pressing buttons.	<ul style="list-style-type: none"> • Off • Quiet (default) • Loud
Channel set-up	Provides access to the Channel set-up menu.	<ul style="list-style-type: none"> • Channel name • 2nd priority channel • Private channels • Frequency band
GPS set-up	Provides access to the GPS set-up menu.	<ul style="list-style-type: none"> • Internal GPS • Homescreen display • Bearing mode • Position requests • Set manual position
DSC set-up	Provides access to the DSC set-up menu.	<ul style="list-style-type: none"> • MMSI • Auto channel change • Position requests
AIS	Enables you to switch on the internal AIS receiver, where applicable.	<ul style="list-style-type: none"> • Off (default) • On
Network output	Enables you to select the network to be used to output data.	<ul style="list-style-type: none"> • NMEA 2000 • 0183 High speed • 0183 Std speed
ATIS set-up	Enables you to switch ATIS mode on and off and enter your ATIS ID.	<ul style="list-style-type: none"> • ATIS • ATIS ID
Maintenance	Enables you to view system details and functions that may be required during maintenance and troubleshooting.	<ul style="list-style-type: none"> • About this unit • System reset • System test





Display Set-up menu

The following menu options are available from the Display Set-up menu.

Menu	Description	Options
Backlight	Increases and decreases the LCD and button backlight level.	<ul style="list-style-type: none">• 0 to 9• Off
Shared brightness	Enables set-up of Shared Brightness.	<ul style="list-style-type: none">• Shared brightness• Group
Contrast	Increases and decreases the LCD Contrast level.	<ul style="list-style-type: none">• 0 to 10
Homescreen display	Determines the details displayed onscreen.	<ul style="list-style-type: none">• Location & Time• Location & COG/SOG



Shared Brightness menu

The following menu options are available from the Shared Brightness menu.

Menu	Description	Options
Shared brightness	Enables and disables Shared Brightness.	<ul style="list-style-type: none">• On• Off
Group	Enables you to assign the radio to a Shared Brightness group.	<ul style="list-style-type: none">• Helm 1• Helm 2• Cockpit• Flybridge• Mast• Group 1 to Group 5





Chapter 8: Hailer, Fog horn, and Intercom

Chapter contents

- [8.1 Hailer Fog Intercom menu on page 62](#)
- [8.2 Loud Hailer on page 62](#)
- [8.3 Fog horn on page 62](#)
- [8.4 Intercom on page 63](#)



8.1 Hailer Fog Intercom menu

The menu options available are determined by the device connected to your radio.

Menu name	Connected devices
Hail/Fog/Int	Loud hailer and second station connected.
Hailer/Fog	Loud hailer connected, no second station
Intercom	Second station connected, no loud hailer

Note: For simplicity the procedures in this section all refer to the **Hail/Fog/Int** menu.

8.2 Loud Hailer

The Ray70 and Ray90 can be connected to a Loud Hailer.

In hailer mode anything spoken into the handset is amplified and broadcast from the hailer; however, the message is not transmitted over VHF channels.

When the hailer is active VHF calls cannot be sent or received.

Using the hailer

From the **Hail/Fog/Int** menu: **Menu > Hail/Fog/Int.**

1. Select **Hailer**.
Hailer mode is now active
2. Press and hold the **PTT** button.
3. Speak your message.
4. Release the **PTT** button.
5. Press the **Back** button to exit Hailer mode.
6. The hailer listening volume can be adjusted at any time in Listening mode using the **Volume Control**.
7. The hailer talking volume can be adjusted at any time, with the **PTT** button pressed using the **Volume Control**.

8.3 Fog horn

The fog horn function requires an optional loud hailer to be connected. Please check your product description to ensure a loud hailer can be connected.

The fog horn function can be set to manual or to predefined automatic modes.

In manual mode a continuous tone is sounded for as long as the **PTT** button is pressed.

In automatic mode the selected tone will repeat every 2 minutes until interrupted or cancelled. In automatic mode the radio can be used as normal between the fog horn patterns.

Fog mode	Description	Pattern
Underway	Vessel underway	1 long tone
Underway/Stopped	Vessel not underway	2 long tones
Sailing/Fishing	sailing vessel or any vessel fishing but not trolling	1 long tone and 2 short tones
Restricted/Tow	Restricted in ability to maneuver or towing another vessel	1 long tone and 2 short tones
Under tow	This vessel is being towed	1 long tone and 3 short tones
Pilot vessel	This vessel is a pilot vessel	4 short tones
At anchor	Vessel is at anchor	12 consecutive rings
Aground	Vessel is aground	3 short rings, 12 consecutive rings, 3 short rings

Using the fog horn in manual mode

From the **Hail/Fog/Int** menu: **Menu > Hail/Fog/Int.**





1. Select **Fog horn**.
2. Select **Manual mode**.
3. Press and hold the **PTT** button to sound a continuous fog horn tone.
4. Press the **Back** button to exit Fog horn mode.

Using automatic fog horn modes

From the **Hail/Fog/Int** menu: **Menu > Hail/Fog/Int**.

1. Select **Fog horn**.
2. Select **Automatic mode**.
3. Select an automatic pattern.
The selected pattern will play and repeat until interrupted.
4. Select **Stop fog horn** to exit the automatic fog horn mode, or
5. Select **Change pattern** to select a different fog horn pattern.
6. To continue using the radio whilst in automatic fog horn mode select **Back** 4 times to return to the Homescreen.

You can now continue to use the radio as normal. The fog horn pattern will continue to repeat every 2 minutes. If you are making a call when it is due to sound the fog horn will be suspended until you finish your call.

Switching off Fog Horn mode

Automatic Fog Horn mode will remain active until switched off.

From the **Hail/Fog/Int** menu: **Menu > Hail/Fog/Int**.

1. Select **Fog horn**.
2. Select **Stop fog horn** to switch off the automatic fog horn mode

8.4 Intercom

The Intercom function is available when more than 1 station is connected to your radio.

The intercom function allows voice communication between handset stations. Calls can be initiated from either station.

Using the intercom

From the **Hail/Fog/Int** menu: **Menu > Hail/Fog/Int**.

1. Select **Intercom**.
The other station will ring.
2. Wait for the handset station to acknowledge the call.
3. Press and hold the **PTT** button and speak your message.





Responding to the intercom

1. Press the **PTT** button and acknowledge the call and to respond to subsequent voice messages.





Chapter 9: Maintenance

Chapter contents

- [9.1 Maintenance on page 66](#)





9.1 Maintenance

This product has no user serviceable parts or adjustments. Never remove the cover or attempt to service the product, doing so may invalidate your product warranty.

The following preventive measures should be followed:

- Although the product is waterproof, keep the unit as dry as possible.
- If you remove a handset connection ensure the dust cap is fitted to the connector.

Routine checks

The following periodic checks should be made:

- Examine cables for signs of damage, such as chafing, cuts or nicks.
- Check that the cable connectors are firmly attached and that their locking mechanisms are properly engaged.

Note: Cable checks should be carried out with the power supply switched off.

Caution: Product cleaning

When cleaning products:

- Lightly rinse or flush with clean, cool fresh water.
- If your product has a display screen, do NOT wipe the screen with a dry cloth, as this could scratch the screen coating.
- Do NOT use: abrasive, acidic, ammonia, solvent or chemical based cleaning products.
- Do NOT use a jet wash.

Unit cleaning instructions

The unit does not require regular cleaning. However, if you find it necessary to clean the unit, please follow the steps below:

1. Ensure power is switched off.
2. Wipe unit clean with a damp cloth.
3. If necessary, use a mild detergent solution to remove grease marks.





Chapter 10: Troubleshooting

Chapter contents

- [10.1 Troubleshooting on page 68](#)
- [10.2 Power up troubleshooting on page 69](#)
- [10.3 VHF Radio troubleshooting on page 71](#)
- [10.4 GNSS \(GPS\) troubleshooting on page 72](#)





10.1 Troubleshooting

The troubleshooting information provides possible causes and corrective action required for common problems associated with installation and operation of your product.

Before packing and shipping, all Raymarine products are subjected to comprehensive testing and quality assurance programs. If you do experience problems with your product this section will help you to diagnose and correct problems in order to restore normal operation.

If after referring to this section you are still having problems with your product, please refer to the Technical support section of this manual for useful links and Raymarine Product Support contact details.

Performing a system reset

Note: Performing a reset will not reset MMSI and ATIS ID number.

From the Maintenance menu: **Menu > Set-up > Maintenance.**

1. Select **System reset.**
2. Select **Yes.**

The system is now reset to factory defaults.

Note: Performing the reset will delete all contacts in your phonebook and reset all user options.

System test

The system test menu can be used to show the status of the system and connected devices.

The System test menu show the status of the following system components and connected devices:

- GPS
- DSC
- Battery
- Hailer
- Remote handset





10.2 Power up troubleshooting

Problems at power up and their possible causes and solutions are described here.

Product does not turn on or keeps turning off

Possible causes	Possible solutions
Blown fuse / tripped breaker	<ol style="list-style-type: none"> 1. Check condition of relevant fuses and breakers and connections, replace if necessary (Refer to Chapter 12 Technical specification for fuse ratings.) 2. If fuse keeps blowing check for cable damage, broken connector pins or incorrect wiring.
Poor / damaged / insecure power supply cable / connections	<ol style="list-style-type: none"> 1. Check that the power cable connector is fully inserted into the unit and locked in position. 2. Check the power supply cable and connectors for signs of damage or corrosion, replace if necessary. 3. With the unit turned on, try flexing the power cable near to the display connector to see if this causes the unit to re-boot/loose power, replace if necessary. 4. Check the vessel's battery voltage, the condition of the battery terminals and power supply cables, ensuring connections are secure, clean and free from corrosion, replace if necessary. 5. With the product under load, using a multi-meter, check for high voltage drop across all connectors/fuses etc, replace if necessary.
Incorrect power connection	The power supply may be wired incorrectly, ensure the installation instructions have been followed. (Refer to Chapter 4 Cables and connections for cable and connection requirements.)
Power source insufficient	With the product under load, using a multi-meter, check the power supply voltage as close to the unit as possible to establish actual voltage when the current is flowing. (Refer to Chapter 12 Technical specification for power supply requirements.)

Product will not boot up (re-boot loop)

Possible causes	Possible solutions
Power supply and connection	See possible solutions from 'Products does not turn on or keeps turning off' above.
Software corruption	<ol style="list-style-type: none"> 1. In the unlikely event that the products software has become corrupted please try re-flashing the latest software from the Raymarine website.





Product does not turn on or keeps turning off

Possible causes	Possible solutions
Blown fuse / tripped breaker	<ol style="list-style-type: none"> 1. Check condition of relevant fuses and breakers and connections, replace if necessary (Refer to Chapter 12 Technical specification for fuse ratings.) 2. If fuse keeps blowing check for cable damage, broken connector pins or incorrect wiring.
Poor / damaged / insecure power supply cable / connections	<ol style="list-style-type: none"> 1. Check that the power cable connector is fully inserted into the unit and locked in position. 2. Check the power supply cable and connectors for signs of damage or corrosion, replace if necessary. 3. With the unit turned on, try flexing the power cable near to the display connector to see if this causes the unit to re-boot/loose power, replace if necessary. 4. Check the vessel's battery voltage, the condition of the battery terminals and power supply cables, ensuring connections are secure, clean and free from corrosion, replace if necessary. 5. With the product under load, using a multi-meter, check for high voltage drop across all connectors/fuses etc, replace if necessary.
Incorrect power connection	The power supply may be wired incorrectly, ensure the installation instructions have been followed. (Refer to Chapter 4 Cables and connections for cable and connection requirements.)
Power source insufficient	With the product under load, using a multi-meter, check the power supply voltage as close to the unit as possible to establish actual voltage when the current is flowing. (Refer to Chapter 12 Technical specification for power supply requirements.)

Raymic Handset will not power up

Possible causes	Possible solutions
Handset not turned on	The Raymic handset is compatible with the Ray60, Ray70, Ray90 and Ray91 radios. The Raymic handset is powered separately from the Base station. Press the Power button located on the top of the Handset to power it on.
Software Base station / Handset mismatch	The Raymic handset and Base station must both be running compatible software, refer to the Base station and Handset software compatibility section for details of compatible software versions.
Poor / damaged / insecure cables / connections	<ol style="list-style-type: none"> 1. Check that the Base station is correctly powered. 2. With the Handset turned on, try flexing the cable near to the connectors to see if this causes the Handset to re-boot/loose power, replace if necessary. 3. Check cable connections are secure, clean and free from corrosion, replace if necessary.





10.3 VHF Radio troubleshooting

Problems with your VHF radio and their possible causes and solutions are described below:

DSC functions are not available / working

Possible Causes	Possible Solutions
MMSI number not programmed.	Programme your MMSI number.
Radio is set to ATIS or Marcom-C mode.	Use of DSC is not permitted when in ATIS or Marcom-C mode. You will be unable to make DSC distress and other types of digital selective call. If you are not in an ATIS region switch off ATIS mode: Menu > Set-up > ATIS set-up > ATIS.
Sensitivity set to Local.	With the sensitivity set to Local your reception will be limited Set Sensitivity to Distant: Menu > Set-up > Sensitivity.

Passive speaker no alarm audio

Possible Causes	Possible Solutions
Passive speaker connected to second station connector.	Alarm audio is not available on passive speakers connected to the second station connector. Alarm audio should still be heard via the second station handset.





10.4 GNSS (GPS) troubleshooting

Problems with the GNSS (GPS) and their possible causes and solutions are described below.

Before troubleshooting GNSS (GPS) problems, ensure your product has the latest software, by checking the Software Updates page on the Raymarine website www.raymarine.com.

No fix

Possible causes	Possible solutions
GNSS (GPS) switched off.	Ensure your internal GNSS (GPS) receiver is switched on.
Geographic location or prevailing conditions preventing satellite fix.	Check periodically to see if a fix is obtained in better conditions or another geographic location.
GNSS (GPS) Antenna location.	For optimum performance the antenna should be mounted above decks and have a clear, unobstructed view of the sky, and not be in close proximity to any structural bulkheads or other electrical equipment or cables which may cause interference.

No position data

Possible causes	Possible solutions
Internal receiver is switched off.	Ensure your external or internal receiver is switched on.
Wrong Network output selected.	Ensure the correct network type and speed is selected in the Network output menu: Menu > Set-up > Network output .
Poor / damaged / insecure cable / connection.	<ol style="list-style-type: none"> 1. Check that the connectors are fully inserted into the unit and locked in position. 2. Check the cables and connectors for signs of damage or corrosion, replace if necessary. 3. Check the vessel's battery voltage, the condition of the battery terminals and power supply cables, ensuring connections are secure, clean and free from corrosion, replace if necessary. 4. With the product under load, using a multi-meter, check for high voltage drop across all connectors/fuses etc, replace if necessary.

GPS data output

The Ray90 and Ray91 include an internal GPS receiver. However, these products do NOT output GPS data to external devices.





Chapter 11: Technical support

Chapter contents

- [11.1 Raymarine product support and servicing on page 74](#)
- [11.2 Viewing product information on page 75](#)
- [11.3 Learning resources on page 75](#)

11.1 Raymarine product support and servicing

Raymarine provides a comprehensive product support service, as well as warranty, service, and repairs. You can access these services through the Raymarine website, telephone, and e-mail.

Product information

If you need to request service or support, please have the following information to hand:

- Product name.
- Product identity.
- Serial number.
- Software application version.
- System diagrams.

You can obtain this product information using the menus within your product.

Servicing and warranty

Raymarine offers dedicated service departments for warranty, service, and repairs.

Don't forget to visit the Raymarine website to register your product for extended warranty benefits: <http://www.raymarine.co.uk/display/?id=788>.

Region	Tele- phone	E-mail
United Kingdom (UK), EMEA, and Asia Pacific	+44 (0)1329 246 932	emea.service@raymarine.com
United States (US)	+1 (603) 324 7900	rm-usrepair@fir.com

Web support

Please visit the "Support" area of the Raymarine website for:

- **Manuals and Documents** — <http://www.raymarine.com/manuals>
- **FAQ / Knowledgebase** — <http://www.raymarine.com/knowledgebase>
- **Technical support forum** — <http://forum.raymarine.com>
- **Software updates** — <http://www.raymarine.com/software>

Telephone and e-mail support

Region	Tele- phone	E-mail
United Kingdom (UK), EMEA, and Asia Pacific	+44 (0)1329 246 777	support.uk@raymarine.com
United States (US)	+1 (603) 324 7900 (Toll-free: +800 539 5539)	support@raymarine.com
Australia and New Zealand	+61 2 8977 0300	aus.support@raymarine.com (Raymarine subsidiary)
France	+33 (0)1 46 49 72 30	support.fr@raymarine.com (Raymarine subsidiary)
Germany	+49 (0)40 237 808 0	support.de@raymarine.com (Raymarine subsidiary)

Region	Tele- phone	E-mail
Italy	+39 02 9945 1001	support.it@raymarine.com (Raymarine subsidiary)
Spain	+34 96 2965 102	sat@azimut.es (Authorized Raymarine distributor)
Netherlands	+31 (0)26 3614 905	support.nl@raymarine.com (Raymarine subsidiary)
Sweden	+46 (0)317 633 670	support.se@raymarine.com (Raymarine subsidiary)
Finland	+358 (0)207 619 937	support.fi@raymarine.com (Raymarine subsidiary)
Norway	+47 692 64 600	support.no@raymarine.com (Raymarine subsidiary)
Denmark	+45 437 164 64	support.dk@raymarine.com (Raymarine subsidiary)
Russia	+7 495 788 0508	info@mikstmarine.ru (Authorized Raymarine distributor)



11.2 Viewing product information

Product information can be found on the Startup screen.

1. Power up the radio.

The startup screen is displayed which shows the model and software version of the product.

Alternatively product information can also be displayed by selecting **About this unit** from the **Maintenance** menu: **Menu > Set-up > Maintenance**.

11.3 Learning resources

Raymarine has produced a range of learning resources to help you get the most out of your products.

Video tutorials

	<p>Raymarine official channel on YouTube:</p> <ul style="list-style-type: none"> • http://www.youtube.com/user/RaymarineInc
	<p>Video Gallery:</p> <ul style="list-style-type: none"> • http://www.raymarine.co.uk/view/?id=2679
	<p>Product Support videos:</p> <ul style="list-style-type: none"> • http://www.raymarine.co.uk/view/?id=4952

Note:

- Viewing the videos requires a device with an Internet connection.
- Some videos are only available in English.

Training courses

Raymarine regularly runs a range of in-depth training courses to help you make the most of your products. Visit the Training section of the Raymarine website for more information:

- <http://www.raymarine.co.uk/view/?id=2372>

FAQs and Knowledge Base

Raymarine has produced an extensive set of FAQs and a Knowledge Base to help you find more information and troubleshoot any issues.

- <http://www.raymarine.co.uk/knowledgebase/>





Technical support forum

You can use the Technical support forum to ask a technical question about a Raymarine product or to find out how other customers are using their Raymarine equipment. The resource is regularly updated with contributions from Raymarine customers and staff:

- <http://forum.raymarine.com>



Chapter 12: Technical specification

Chapter contents

- [12.1 Technical specification on page 78](#)
- [12.2 Radio usage on page 79](#)

12.1 Technical specification

The following technical specification apply to the Ray90 and Ray91.

Environmental specification

Operating temperature	-20°C (-4°F) to +60°C (140°F)
Storage temperature	-25°C (-13°F) to +70°C (158°F)
Relative humidity	95%
Water proofing	IPx6 & IPx7
Connections	<ul style="list-style-type: none"> • 1 x SeaTalkng® / NMEA 2000 • 1 x NMEA 0183 input • 1 x NMEA 0183 output • 2 x Handset station connectors • 1 x VHF antenna / splitter connector • 1 x TNC GNSS (GPS) antenna connector • 1 x Loud Hailer connection

Power specification

Nominal supply voltage	12 V dc (with over voltage protection)
Operating voltage range	10.2 V dc to 16 V dc

Current consumption	<ul style="list-style-type: none"> • Less than 6 A at high power (13.6 V) • Standby: 600 mA • Receive: 2 A • Loud hailer: 3 A (8 Ω) / 6 A (4 Ω)
LEN	1

VHF Transmitter

Channels	All available US, International and Canadian VHF marine bands
Frequency Range	156.025 MHz to 157.425 MHz / 155.500 MHz to 161.425 MHz (Private channels)
Frequency stability	+/- 1.5 ppm
Channel Spacing	25kHz
Power Output	<ul style="list-style-type: none"> • Low power setting — 1 W • High power setting — 25 W
Spurious emissions	Better than -36 dBm at 25 W (Less than 0.25 μW)
Maximum deviation	+/- 5 KHz
Antenna impedance	50 Ohms (typical)

Receiver

Receiver type	Double conversion super heterodyne
Channels	All available US, International and Canadian VHF marine bands

Frequency range	156.050 MHz to 163.275 MHz / 155.500 MHz to 161.425 MHz (Private channels)
Sensitivity	Better than 1 microvolt EMF @ 20dB SINAD
Squelch sensitivity	Less than -2 dBμ EMF
Hum and noise	Better than -40 dB
Audio distortion	Less than 10%
Receiver sensitivity	<ul style="list-style-type: none"> • Distance — 119dBm (0.25uV) @ 12dB SINAD (typical) • Local — 110dBm (0.7uV) @ 12dB SINAD (typical)
Adjacent channel selectivity	More than 70 dB
Spurious response rejection	More than 70 dB
Inter modulation rejection	More than 68 dB

Speakers

External speaker power output	4 W (8 Ω)
Handset speaker power output	1 W (16 Ω)
Hailer speaker power output	24 W (4 Ω)

AIS (Ray91 only)

Class type	AIS receiver only
------------	-------------------

GNSS

Channels	72
Cold start	29 seconds



Receiver IC Sensitivity	<ul style="list-style-type: none"> • Tracking and navigation = -167 dBm • Reacquisition = -160 dBm • Cold start = -146 dBm • Hot start = -156 dBm
GNSS compatibility	<ul style="list-style-type: none"> • GPS • GLONASS • Beidou
SBAS compatibility	<ul style="list-style-type: none"> • QZSS • WAAS • EGNOS • MSAS • GAGAN
Special features	Active Jamming and Interference Reduction
Operating frequency	<ul style="list-style-type: none"> • GPS L1 C/A • GLONASS L10F • Beidou B1
Signal Acquisition	Automatic
Almanac Update	Automatic
Geodetic Datum	WGS-84 (alternatives available through Raymarine MFD)
Refresh Rate	20 Hz (20 times per second Concurrent GNSS)
Antenna	<ul style="list-style-type: none"> • External passive
Horizontal Position Accuracy	<ul style="list-style-type: none"> • Autonomous = 2.5m (8.2 ft) • SBAS = 2m (6.56 ft)

T

Technical specification





12.2 Radio usage

The radio can be used worldwide, including the following European countries:

A	CZ	FI	IE	LU	PL	SK
BE	DE	FR	IS	LV	PT	TR
BG	DK	GB	IT	MT	RO	
CH	EE	GR	LI	NL	SE	
CY	ES	HU	LT	NO	SI	





Appendix A NMEA 0183 sentences

The radio supports the following **NMEA 0183** sentences.

Sentence	Description	Ray90		Ray91	
		Receive	Transmit	Receive	Transmit
DSC	Digital Selective Calling		●		●
DSE	Expanded Digital Selective Calling		●		●
VDM	AIS VHF Data Link Message				●
GGA	Global Positioning System Fix Data	●		●	
GLL	Geographic Position — Lat/Long	●		●	
GNS	GNSS Fix Data	●		●	
RMA	Recommended Minimum Specific Loran-C Data	●		●	
RMC	Recommended Minimum Specific GNSS Data	●		●	
DTM	Datum	●		●	





Appendix B NMEA 2000 PGN list

The radio supports the following **NMEA 2000** PGNs. These are applicable to **NMEA 2000** and **SeaTalkng**® protocols.

PGN	Description	Ray90		Ray91	
		Receive	Transmit	Receive	Transmit
59392	ISO Request	●	●	●	●
59904	ISO Acknowledgement	●	●	●	●
60928	ISO Address Claim	●	●	●	●
126208	NMEA – Group Function	●	●	●	●
126464	PGN List		●		●
126996	Product Information		●		●
127258	Magnetic variation	●		●	
129026	COG / SOG Rapid Update	●		●	
129029	GNSS Position Data	●		●	
129038	AIS Class A Position Report				●
129039	AIS Class B Position Report				●
129040	AIS Class B Extended Position Report				●
129041	AIS Aids to Navigation (AtONs)				●
129044	Datum	●		●	
129793	AIS UTC and Date Report				●
129794	AIS Class A Static and Voyage Related data				●
129798	AIS SAR Aircraft Position Report				●
129801	AIS Addressed Safety Related Message				●
129802	AIS Safety Related Broadcast Message				●
129808	DSC Call Information		●		●





PGN	Description	Ray90		Ray91	
		Receive	Transmit	Receive	Transmit
129809	AIS Class B "CS" Static Data Report, Part A				●
129810	AIS Class B "CS" Static Data Report, Part B				●





Appendix C MMSI Regulatory bodies and application submissions

Country	Regulatory Body	Website links
UK	Ofcom	http://www.ofcom.org.uk
USA	FCC (www.fcc.gov)	<ul style="list-style-type: none">• www.boatus.com• www.seatow.com• www.usps4mmsi.com
Canada	Industry Canada	www.ic.gc.ca
Australia	Australian Maritime Safety Authority (AMSA)	http://www.amsa.gov.au/mmsi/
Holland	Agentschap Telecom	www.agentschaptelecom.nl
Belgium	Belgisch Instituut voor Postdiensten en Telecommunicatie	www.bipt.be
Germany	Bundesnetzagentur	https://www.bundesnetzagentur.de/DE/Sachgebiete/Telekommunikation/Unternehmen_Institutionen/Frequenzen/SpezielleAnwendungen/Seefunk/See-funk-node.html
Denmark	søfartsstyrelsen	www.sofartsstyrelsen.dk
France	Agence Nationale Des Fréquences	https://www.anfr.fr/licences-et-autorisations/radiomaritime/
Italy	Ministero dello sviluppo economico - Direzione generale per le attività territoriali	http://www.sviluppoeconomico.gov.it/images/stories/documenti/mmsinew.pdf
Spain	Ministero De Fomento	https://www.fomento.gob.es/MFOM/LANG_CASTELLANO/DIRECCIONES_GENERALES/MARINA_MERCANTE/RADIOCOMUNICACIONES/MMSI/
Sweden	PTS	www.pts.se
Finland	Viestintävirasto	https://www.viestintavirasto.fi/en/spectrum/radioliceses/Boatingandnavigation.html
Iceland	Post and telecom administration in Iceland	www.pfs.is
New Zealand	Radio Spectrum Management	https://www.rsm.govt.nz/licensing/radio-operator-certificates-and-callsigns?searchterm=MMSI





Country	Regulatory Body	Website links
Chile	Directemar	www.nauticentro.cl
Panama	Autoridad Maritima de Panama	www.amp.gob.pa/newside/spanish/puertos2/depima/ima.html





Appendix D VHF Channels

US Marine VHF Channels and Frequencies

Note: Some of the channel numbers have recently changed. For completeness, both old and new numbers are shown in the table below.

(New) CH No.	(Old) CH No.	TX Freq	RX Freq	Single Freq	Use
1001	01A	156.050	156.050	x	Port operations and commercial, VTS. Available only in New Orleans / Lower Mississippi area.
1003	03A	156.150	156.150	x	US Government only.
1005	05A	156.250	156.250	x	Port operations or VTS in the Houston, New Orleans and Seattle areas.
06	06	156.300	156.300	x	Intership Safety.
1007	07A	156.350	156.350	x	Commercial.
08	08	156.400	156.400	x	Commercial (Intership only).
09	09	156.450	156.450	x	Boater calling. Commercial and Non-commercial.
10	10	156.500	156.500	x	Commercial.
11	11	156.550	156.550	x	Commercial. VTS in selected areas.
12	12	156.600	156.600	x	Port operations. VTS in selected areas.
13	13	156.650	156.650	x	Intership navigation safety (Bridge-to-bridge). Ships >20 metres in length maintain a listening watch on this channel in US waters.
14	14	156.700	156.700	x	Port operations. VTS in selected areas.
15	15	-	156.750	x	Environmental (Receive only). Used by Class 'C' EPIRBs.
16	16	156.800	156.800	x	International Distress, Safety and Calling. Ships required to carry radio, USCG, and most coast stations maintain a listening watch on this channel.
17	17	156.850	156.850	x	State Control.





(New) CH No.	(Old) CH No.	TX Freq	RX Freq	Single Freq	Use
1018	18A	156.900	156.900	x	Commercial.
1019	19A	156.950	156.950	x	Commercial.
20	20	157.000	161.600		Port operations (duplex).
1020	20A	157.000	157.000	x	Port operations.
1021	21A	157.050	157.050	x	US Coast Guard only.
1022	22A	157.100	157.100	x	Coast Guard Liaison and Maritime Safety Information Broadcasts. Broadcasts announced on channel 16.
1023	23A	157.150	157.150	x	US Coast Guard only.
24	24	157.200	161.800		Public correspondence (Marine operator).
25	25	157.250	161.850		Public correspondence (Marine operator).
26	26	157.300	161.900		Public correspondence (Marine operator).
27	27	157.350	161.950		Public correspondence (Marine operator).
28	28	157.400	162.000		Public correspondence (Marine operator).
1061	61A	156.075	156.075	x	US Government only.
1063	63A	156.175	156.175	x	Port operations and commercial VTS, Available only in New Orleans / Lower Mississippi area.
1064	64A	156.225	156.225	x	US Coast Guard only.
1065	65A	156.275	156.275	x	Port operations.
1066	66A	156.325	156.325	x	Port operations.
67	67	156.375	156.375	x	Commercial. Used for bridge-to-bridge communications in lower Mississippi river (Intership only).
68	68	156.425	156.425	x	Non-commercial.
69	69	156.475	156.475	x	Non-commercial.
71	71	156.575	156.575	x	Non-commercial.
72	72	156.625	156.625	x	Non-commercial (Intership only).





(New) CH No.	(Old) CH No.	TX Freq	RX Freq	Single Freq	Use
73	73	156.675	156.675	x	Port operations.
74	74	156.725	156.725	x	Port operations.
77	77	156.875	156.875	x	Port operations (Intership only).
1078	78A	156.925	156.925	x	Non-commercial.
1079	79A	156.975	156.975	x	Commercial. Non-commercial in Great Lakes only).
1080	80A	157.025	157.025	x	Commercial. Non-commercial in Great Lakes only).
1081	81A	157.075	157.075	x	US Government only — Environmental protection operations.
1082	82A	157.125	157.125	x	US Government only.
1083	83A	157.175	157.175	x	US Government only.
84	84	157.225	161.825		Public correspondence (Marine operator).
85	85	157.275	161.875		Public correspondence (Marine operator).
86	86	157.325	161.925		Public correspondence (Marine operator).
87	87	157.375	161.975		Public correspondence (Marine operator).
88	88	157.425	162.025		Public correspondence only near the Canadian border
1088	88A	157.425	157.425	x	Commercial, Intership only.
AIS 1	AIS 1		161.975	x	Automatic Identification System (AIS)
AIS 2	AIS 2		162.025	x	Automatic Identification System (AIS)

Please be aware that:

- Recreational boaters normally use channels listed as Non-commercial: 68, 69, 71, 72 78A.
- Channel 70 is used exclusively for DSC and is not available for regular voice communications.
- Channels 75 and 76 are reserved as guards bands for channel 16 and are not available for regular voice communications.
- Channels AIS 1 and AIS 2 are only supported by VHF products which include an AIS receiver.



**Note:**

1. The letter 'A' following a channel number indicates simplex use of the ship station transmit side of an international semi-duplex channel. Operations are different from that of international operations on that channel.
2. Channel 13 should be used to contact a ship when there is danger of collision. All ships of length 20 metres or greater are required to guard VHF channel 13, in addition to VHF channel 16, when operating within US territorial waters.
3. Channel 15 is receive only.
4. Channel 16 is used for calling other stations or for distress calls.
5. Channel 17 and channel 77 have a fixed power output of 1 watt.
6. Channel 13 and channel 67 have an initial power output of 1 watt. User can temporarily override this restrictions to transmit at high power.

Canadian Marine VHF Channels and Frequencies

Note: Some of the channel numbers have recently changed. For completeness, both old and new numbers are shown in the table below.

(New) CH No.	(Old) CH No.	TX Freq	RX Freq	Area of operation	Use
01	01	156.050	160.650	PC	Public correspondence.
02	02	156.100	160.700	PC	Public correspondence.
03	03	156.150	160.750	PC	Public correspondence.
1004	04A	156.200	156.200	PC	Intership, ship/shore and safety: Canadian Coast Guard search and rescue.
1004	04A	156.200	156.200	EC	Intership, ship/shore and commercial: Commercial fishing only.
1005	05A	156.250	156.250		Ship movement.
06	06	156.300	156.300	All areas	Intership, commercial, non-commercial and safety: Maybe used for search and rescue communications between ships and aircraft.
1007	07A	156.350	156.350	All areas	Intership, ship/shore, commercial.
08	08	156.400	156.400	WC, EC	Intership, commercial and safety. Also assigned for operations in the Lake Winnipeg area.
09	09	156.450	156.450	AC	Intership, ship/shore, commercial, non-commercial and ship movement. Maybe used to communicate with aircraft and helicopters in predominantly maritime support operations.





(New) CH No.	(Old) CH No.	TX Freq	RX Freq	Area of operation	Use
10	10	156.500	156.500	AC, GL	Intership, ship/shore, commercial, non-commercial, safety and ship movement. May also be used for communications with aircraft engaged in coordinated search and rescue and antipollution operations.
11	11	156.550	156.550	PC, AC, GL	Intership, ship/shore, commercial, non-commercial and ship movement. Also used for pilotage purposes.
12	12	156.600	156.600	WC, AC, GL	Intership, ship/shore, commercial, non-commercial and ship movement. Port operations and pilot information and messages.
13	13	156.650	156.650	All areas	Intership, commercial, non-commercial and ship movement. Exclusively for bridge-to-bridge navigational traffic. Limited to 1 watt maximum power.
14	14	156.700	156.700	AC, GL	Intership, ship/shore, commercial, non-commercial and ship movement. Port operations and pilot information and messages.
15	15	156.750	156.750	All areas	Intership, ship/shore, commercial, non-commercial and ship movement. All operations limited to 1 watt maximum power. May also be used for on-board communications.
16	16	156.800	156.800	All areas	International distress, safety and calling.
17	17	156.850	156.850	All areas	Intership, ship/shore, commercial, non-commercial and ship movement. All operations limited to 1 watt maximum power. May also be used for on-board communications.
1018	18A	156.900	156.900	All areas	Intership, ship/shore, commercial. Towing on the Pacific coast.
1019	19A	156.950	156.950	All areas except PC	Intership, ship/shore. Canadian Coast Guard only
1019	19A	156.950	156.950	PC	Intership, ship/shore. Various government departments.
20	20	157.00	161.600	All areas	Ship/shore, safety and ship movement. Port operations limited to 1 watt maximum power.
1021	21A	157.050	157.050	All areas	Intership and ship/shore. Canadian Coast Guard only.
2021	21B	-	161.650	All areas	Safety: Continuous Marine Broadcast (CMB) service.





(New) CH No.	(Old) CH No.	TX Freq	RX Freq	Area of operation	Use
1022	22A	157.100	157.100	All areas	Intership, ship/shore, commercial and non-commercial. For communications between Canadian Coast Guard and non-Canadian Coast Guard stations only.
23	23	157.150	161.750	PC	Ship/shore and public correspondence. Also in the inland waters of British Columbia
24	24	157.200	161.800	All areas	Ship/shore and public correspondence.
25	25	157.250	161.850	PC	Ship/shore and public correspondence. Also assigned for operations in the Lake Winnipeg area.
2025	25B	-	161.850	AC	Safety: Continuous Marine Broadcast (CMB) service.
26	26	157.300	161.900	All areas	Ship/shore, safety and public correspondence.
27	27	157.350	161.950	AC, GL, PC	Ship/shore and public correspondence.
28	28	157.400	162.00	PC	Ship/shore, safety and public correspondence.
2028	28B	-	162.000	AC	Safety: Continuous Marine Broadcast (CMB) service.
60	60	156.025	160.625	PC	Ship/shore and public correspondence.
1061	61A	156.075	156.075	PC	Intership and ship/shore Canadian Coast Guard only.
1061	61A	156.075	156.075	EC	Intership, ship/shore and commercial Commercial fishing only.
1062	62A	156.125	156.125	PC	Intership and ship/shore Canadian Coast Guard only.
1062	62A	156.125	156.125	EC	Intership, ship/shore and commercial Commercial fishing only.
64	64	156.225	160.825	PC	Ship/shore and public correspondence.
1064	64A	156.225	156.225	EC	Intership, ship/shore and commercial Commercial fishing only.





(New) CH No.	(Old) CH No.	TX Freq	RX Freq	Area of operation	Use
1065	65A	156.275	156.275		Intership, ship/shore, commercial, non-commercial and safety. Search and rescue and antipollution operations on the Great Lakes. Towing on the Pacific coast. Port operations only in the St. Lawrence river area limited to 1 watt maximum power. Pleasure craft in the inland waters of Alberta, Saskatchewan and Manitoabs (excluding Lake Winnipeg and the Red River.
1066	66A	156.325	156.325		Intership, ship/shore, commercial, non-commercial, safety and ship movement. Port operations only in the St. Lawrence river / Great Lakes areas limited to 1 watt maximum power.
67	67	156.375	156.375	EC	Intership ship/shore and commercial. Commercial fishing only.
67	67	156.375	156.375	All areas except EC	Intership, ship/shore, commercial, non-commercial, safety. May also be used for communications with aircraft engaged in coordinated search and rescue and antipollution operations.
68	68	156.425	156.425	All areas	Intership, ship/shore and non-commercial. For marinas and yacht clubs.
69	69	156.475	156.475	All areas except EC	Intership, ship/shore, commercial and non-commercial.
69	69	156.475	156.475	EC	Intership, ship/shore and commercial. Commercial fishing only.
71	71	156.575	156.575	PC	Intership, ship/shore, commercial, non-commercial, safety and ship movement.
71	71	156.575	156.575		Intership, ship/shore and non-commercial. For marinas and yacht clubs on the east coast and on Lake Winnipeg.
72	72	156.625	156.625	EC, PC	Intership, commercial and non-commercial May be used to communicate with aircraft and helicopters in predominantly maritime support operations.
73	73	156.675	156.675	EC	Intership, ship/shore and commercial. Commercial fishing only.
73	73	156.675	156.675	All areas except EC	Intership, ship/shore, commercial, non-commercial and safety. May also be used for communications with aircraft engaged in coordinated search and rescue and antipollution operations.
74	74	156.725	156.725	EC, PC	Intership, ship/shore, commercial, non-commercial and ship movement.





(New) CH No.	(Old) CH No.	TX Freq	RX Freq	Area of operation	Use
77	77	156.875	156.875		Intership, ship/shore, safety and ship movement. Pilotage on Pacific coast. Port operations only in the St. Lawrence river / Great Lakes areas limited to 1 watt maximum power.
1078	78A	156.925	156.925	EC, PC	Intership, ship/shore and commercial.
1079	79A	156.975	156.975	EC, PC	Intership, ship/shore and commercial.
1080	80A	157.025	157.025	EC, PC	Intership, ship/shore and commercial.
1081	81A	157.075	157.075		Intership, ship/shore. Canadian Coast Guard use only in the St. Lawrence river / Great Lakes areas.
1081	81A	157.075	157.075	PC	Intership, ship/shore and safety. Canadian Coast Guard antipollution.
1082	82A	157.125	157.125	PC	Intership, ship/shore and safety. Canadian Coast Guard use only.
1082	82A	157.125	157.1258		Intership and ship/shore. Canadian Coast Guard use only in the St. Lawrence river / Great Lakes areas.
83	83	157.175	161.775	PC	Ship/shore and safety. Canadian Coast Guard use only.
1083	83A	157.175	157.175	EC	Intership and ship/shore Canadian Coast Guard and other government agencies.
2083	83B	-	161.775	AC, GL	Safety: Continuous Marine Broadcast (CMB) service.
84	84	157.225	161.825	PC	Ship/shore and public correspondence.
85	85	157.275	161.875	AC, GL, NL	Ship/shore and public correspondence.
86	86	157.325	161.925	PC	Ship/shore and public correspondence.
87	87	157.375	161.975	AC, GL, NL	Ship/shore and public correspondence.
88	88	157.425	162.025	AC, GL, NL	Ship/shore and public correspondence.

Area of operation

- **AC** — Atlantic Coast, Gulf and St. Lawrence River up to and including Montreal.
- **EC** — East Coast: includes NL, AC, GL and Eastern Arctic areas.





- **GL** — Great Lakes: includes St. Lawrence above Montreal.
- **NL** — Newfoundland and Labrador.
- **PC** — Pacific Coast.
- **WC** — West Coast: includes PC, Western Arctic and Athabasca-Mackenzie Watershed areas.
- **All areas** — Includes East and West Coast areas.

Note:

1. An 'A' following a channel number indicates simplex use of the ship station transmit side of an international duplex channel. Operations are different from that of international operations on that channel.
2. Channel 16 is used for calling other stations or for distress calls.
3. A 'B' following a channel number indicates simplex use of the coast station transmit side of an international duplex channel. The channel is receive only
4. Channel 70 is used exclusively for Digital Selective Calling and is not available for regular voice communications.
5. Channel 75 and channel 76 are reserved as guard bands for channel 16 and are not available for regular voice communications.

International Marine VHF Channels and Frequencies

CH No.	TX Freq	RX Freq	Single Freq	Use
01	156.050	160.650		Public correspondence, Port operations and Ship movement.
02	156.100	160.700		Public correspondence, Port operations and Ship movement.
03	156.150	160.750		Public correspondence, Port operations and Ship movement.
04	156.200	160.800		Public correspondence, Port operations and Ship movement.
05	156.250	160.850		Public correspondence, Port operations and Ship movement.
06	156.300	156.300	x	Intership.
07	156.350	160.950		Public correspondence, Port operations and Ship movement.
08	156.400	156.400	x	Intership.
09	156.450	156.450	x	Intership, Port operations and Ship movement.
10	156.500	156.500	x	Intership, Port operations and Ship movement.
11	156.550	156.550	x	Port operations and Ship movement.





CH No.	TX Freq	RX Freq	Single Freq	Use
12	156.600	156.600	x	Port operations and Ship movement.
13	156.650	156.650	x	Intership, Safety, Port operations and Ship movement.
14	156.700	156.700	x	Port operations and Ship movement.
15	156.750	156.750	x	Intership, on-board communications limited to 1 watt maximum power.
16	156.800	156.800	x	Distress, Safety and Calling
17	156.850	156.850	x	Intership, on-board communications limited to 1 watt maximum power.
18	156.900	161.500		Public correspondence, Port operations and Ship movement.
19	156.950	161.550		Public correspondence, Port operations and Ship movement.
1019	156.950	156.950	x	Port operations and Ship movement.
2019	161.550	161.550	x	Port operations and Ship movement.
20	157.000	161.600		Public correspondence, Port operations and Ship movement.
1020	157.000	157.000	x	Public correspondence, Port operations and Ship movement.
2020	161.600	161.600	x	Public correspondence, Port operations and Ship movement.
21	157.050	161.650		Public correspondence, Port operations and Ship movement.
22	157.100	161.700		Public correspondence, Port operations and Ship movement.
23	157.150	161.750		Public correspondence, Port operations and Ship movement.
24	157.200	161.800		Public correspondence, Port operations and Ship movement.
25	157.250	161.850		Public correspondence, Port operations and Ship movement.
26	157.300	161.900		Public correspondence, Port operations and Ship movement.
27	157.350	161.950		Public correspondence, Port operations and Ship movement.
28	157.400	162.000		Public correspondence, Port operations and Ship movement.
37 (M)	157.850	157.850	x	UK Marinas and Yacht Clubs (UK only)
60	156.025	160.625		Public correspondence, Port operations and Ship movement.





CH No.	TX Freq	RX Freq	Single Freq	Use
61	156.075	160.675		Public correspondence, Port operations and Ship movement.
62	156.125	160.725		Public correspondence, Port operations and Ship movement.
63	156.175	160.775		Public correspondence, Port operations and Ship movement.
64	156.225	160.825		Public correspondence, Port operations and Ship movement.
65	156.275	160.875		Public correspondence, Port operations and Ship movement.
66	156.325	160.925		Public correspondence, Port operations and Ship movement.
67	156.375	156.375	x	Intership, Port operations and Ship movement.
68	156.425	156.425	x	Port operations and Ship movement.
69	156.475	156.475	x	Intership, Port operations and Ship movement.
71	156.575	156.575	x	Port operations and Ship movement.
72	156.625	156.625	x	Intership.
73	156.675	156.675	x	Intership.
74	156.725	156.725	x	Port operations and Ship movement.
75	156.775	156.775	x	See Note 5.
76	156.825	156.825	x	See Note 5.
77	156.875	156.875	x	Intership.
78	156.925	161.525		Public correspondence, Port operations and Ship movement.
1078	156.925	156.925	x	Port operations and Ship movement.
2078	161.525	161.525	x	Port operations and Ship movement.
79	156.975	161.575		Public correspondence, Port operations and Ship movement.
1079	156.975	156.975	x	Port operations and Ship movement.
2079	161.575	161.575	x	Port operations and Ship movement.
80	157.025	161.625		Public correspondence, Port operations and Ship movement.





CH No.	TX Freq	RX Freq	Single Freq	Use
81	157.075	161.675		Public correspondence, Port operations and Ship movement.
82	157.125	161.725		Public correspondence, Port operations and Ship movement.
83	157.175	161.775		Public correspondence, Port operations and Ship movement.
84	157.225	161.825		Public correspondence, Port operations and Ship movement.
85	157.275	161.875		Public correspondence, Port operations and Ship movement.
86	157.325	161.925		Public correspondence, Port operations and Ship movement.
87	157.375	157.375	x	Port operations and Ship movement.
88	157.425	157.425	x	Port operations and Ship movement.
M2	161.425	161.425	x	UK Marinas and Yacht Clubs (UK only)
AIS 1	161.975	161.975	x	Automatic Identification System (AIS)
AIS 2	162.025	162.025	x	Automatic Identification System (AIS)

Please be aware that:

- Intership channels are for communications between ship stations. Intership communications should be restricted to channels 6, 8, 72 and 77. If these are not available, the other channels marked for Intership may be used.
- Channel 70 is used exclusively for Digital Selective Calling (DSC) and is not available for regular voice communications.
- Channels AIS 1 and AIS 2 are only supported by VHF products which include an AIS receiver.

Note:

1. Channel 06 may also be used for communications between ship stations and aircraft engaged in coordinated search and rescue operations. Ship stations should avoid harmful interference to such communications on channel 06 as well as to communications between aircraft stations, ice breakers and assisted ships during ice seasons.
2. Within the European Maritime Area and in Canada, channels 10, 67 and 73 may also be used by the individual administrations concerned for communication between ship stations, aircraft stations and participating land stations engaged in coordinated search and rescue and anti-pollution operations in local areas. Channel 10 or 73 (depending on location) are also used for the broadcast of Marine Safety Information by the Maritime and Coast Guard Agency in the UK only.
3. Channel 13 is designated for use on a worldwide basis as a navigation safety communication channel, primarily for intership navigation safety communications.
4. Channels 15 and 17 may also be used for on-board communications provided the effective radiated power does not exceed 1 Watt.
5. The use of channels 75 and 76 should be restricted to navigation related communications only and all precautions should be taken to avoid harmful interference to channel 16. Transmit power is limited to 1 Watt.



**Private Channels (Europe only)**

Country	Channel Designations	TX Freq	RX Freq	Channel Use
Belgium	96	162.425	162.425	Marina
Denmark	L1	155.500	155.500	Pleasure
	L2	155.525	155.525	Pleasure
Finland, Norway & Sweden	L1	155.500	155.500	Pleasure
	L2	155.525	155.525	Pleasure
	L3	155.650	155.650	Pleasure
Holland (Netherlands)	31	157.550	162.150	Marina
	37	157.850	157.850	Leisure
Denmark, Finland, Norway & Sweden	F1	155.625	155.625	Fishing
	F2	155.775	155.775	Fishing
	F3	155.825	155.825	Fishing
United Kingdom	M1	157.850	157.850	Marina
	M2	161.425	161.425	Marina

The national channels listed above have been allocated for the specific use within the countries listed. To use these channels you must have the appropriate license.

WX Channels (North America only)

Weather Channel	Frequency in MHz
WX1	162.550
WX2	162.400
WX3	162.475
WX4	162.425
WX5	162.450
WX6	162.500

Weather Channel	Frequency in MHz
WX7	162.525
WX8	161.650
WX9	161.775
WX10	163.275





Appendix E Phonetic alphabet

To help make call letters more clearly understood, and to assist in spelling out similar sounding or unfamiliar word, radiotelephone users employ the international phonetic alphabet.

A	ALPHA	N	NOVEMBER
B	BRAVO	O	OSCAR
C	CHARLIE	P	PAPA
D	DELTA	Q	QUEBEC
E	ECHO	R	ROMEO
F	FOXTROT	S	SIERRA
G	GOLF	T	TANGO
H	HOTEL	U	UNIFORM
I	INDIA	V	VICTOR
J	JULIET	W	WHISKEY
K	KILO	X	X-RAY
L	LIMA	Y	YANKEE
M	MIKE	Z	ZULU





Appendix F Prowords

Prowords can be used to simplify and speed up radio communications.

Proword	Meaning
ACKNOWLEDGE	Have you received and understood?
CONFIRM	Is that correct?
CORRECTION	An error has been made?
I SAY AGAIN	I repeat (e.g. important information).
I SPELL	Phonetically spelling of the word.
OUT	End of communication.
OVER	I have completed this part of the message and am inviting you to reply.
RECEIVED	Receipt acknowledgement.
SAY AGAIN	Repeat your message.
STATION CALLING	Used when a station is uncertain of the identity of a station which is calling.





Index

A

AIS receiver	56
Applicable products	14
ATIS ID	16

B

Base station	
Power	34
Brightness	
Shared	37

C

Cable bend radius	26
Cable protection	26
Cable routing	20, 26
Cleaning	66
Compass safe distance	20
Connecting SeaTalkng® cables	30
Connection	
Battery	28
Distribution panel	28
Connections	27
DeviceNet	30
General cabling guidance	26
GNSS antenna	31
GPS antenna	31
Loud hailer	31
NMEA 0183	31
NMEA 2000	30
Overview	26
Passive speaker	30
Raymic handset	29
SeaTalkng	30
VHF antenna	31
Contact details	74
Controls	
Handset	34
Raymic	34

D

Dimensions	
Base station	21
Passive speaker	21
Raymic handset	22
Documentation	14

E

Electromagnetic Compatibility	21
EMC	21

F

FCC ID	15
--------------	----

G

GNSS	42
GNSS antenna	14
GPS	42
Data output	72
GPS antenna	14

H

Handset	
Power	34

I

IC ID	15
Installation	
Best practice	29
EMC guidelines	21
surface requirements	20
Ventilation	20
VHF antenna requirements	20
Intercom	63
Interference	
Compass	20
Electrical	20





RF	20
----------	----

L

Licensing	
Additional information	15
Europe and ROW Requirement	15
Industry Canada Requirement	15
Requirement	15
USA Requirement	15
Loud hailer	62

M

MMSI	16
Where to apply	84
Mounting	
Base station	22
Passive speaker	24
Raymic handset	23
MPE	20

N

Network	
Selection	39
NMEA	
Settings	
Baud rate	39
NMEA 0183	
Sentences	81
NMEA 2000	
PGNs	82

P

Parts supplied	16
Power	27
Battery connection	28
Distribution	27
Distribution panel	28

Grounding	29
Sharing a breaker	28
Power cable extension	28
Private channels	
Europe	98
Product	
Documentation	14
Features	14
Overview	15
Product support	74

R

Radio Frequency (RF) interference	20
---	----

S

SeaTalkng®	
Connecting cables	30
Securing cables	26
Service Center	74
Shared brightness	37
Software update	17
Raymic	17
Software version	17
Specification	
AIS Receiver	78
Environmental	78
GNSS (GPS)	78
Power	78
Receiver	78
Speakers	78
VHF Transmitter	78
Strain relief, <i>See</i> Cable protection	

T

Technical specification	77
Technical support	74
Troubleshooting	68
GNSS	72
GPS	72
Power	69





V

VHF antenna	14
VHF channels	
Canada	89
International	94
United States	86

W

Warranty	74
Water ingress	20
Waterproofing	20
WX channels	
North America	98





Owner notes:





Owner notes:





Owner notes:





Raymarine

Marine House, Cartwright Drive, Segensworth, Fareham, Hampshire.
PO15 5RJ, United Kingdom.

Tel: +44 (0)1329 246 700

www.raymarine.com

Raymarine®

a brand by 