

# **Ray218 & Ray55** **Marine VHF Radio** Owner's Handbook

Document number: 81278-1  
Date: December 2006

### **Trademarks and registered trademarks**

Raymarine is a registered trademark of Raymarine plc.

All other product names are trademarks or registered trademarks of their respective owners.

Contents of this handbook © Raymarine 2006

# Contents

Trademarks and registered trademarks .....	2
<b>About this Handbook .....</b>	<b>9</b>
<b>Important Information .....</b>	<b>10</b>
Antenna Mounting and EME Exposure .....	12
Safe Compass Distance .....	12
EMC Conformance .....	12
<b>Chapter 1: Introduction .....</b>	<b>13</b>
1.1 Ray218 and Ray55 Fixed Station VHF Radios .....	13
1.2 Features .....	13
Digital Selective Calling (DSC) .....	14
<b>Chapter 2: Installation .....</b>	<b>15</b>
2.1 Unpacking and Inspection .....	15
Equipment Supplied .....	15
2.2 Planning the Installation .....	16
2.3 Cable Connections .....	19
Power .....	20
RayMic / Mic Relocation .....	21
Hailer Horn .....	21
External Speaker .....	21
NMEA Data .....	21
NMEA IN (from GPS) .....	22
NMEA OUT (to Chartplotter Display) .....	22
Antenna .....	23
Antenna Mounting Suggestions .....	23
Grounding .....	24
<b>Chapter 3: General Operations .....</b>	<b>25</b>
3.1 Keypad and Rotary Knobs .....	25
Microphone Keys .....	26
1. PTT .....	26
2. HILO / LOC DIST .....	26
3. 16/9 .....	26
4. UP/DOWN .....	26
5. SCAN / SAVE .....	26
Transceiver Controls .....	26
6. CH/OK .....	26
7. PWR/VOL .....	26
8. SQ .....	26
9. Soft Keys .....	27
Transceiver Push Keys .....	27

10. HAILER / INTCM .....	27
11. MENU/DSC .....	27
12. CLEAR/WX .....	27
13. 16/9 .....	27
14. DISTRESS .....	27
Optional RayMic Second Station .....	28
A. PTT .....	28
B. VOL/SQ .....	28
C. CLEAR/WX .....	29
D. 16/9 .....	29
E. Soft Keys .....	29
F. MENU / DSC .....	29
G. CH .....	29
H. OK / INTCM .....	29
3.2 Transceiver LCD .....	30
1. (RX) Receiving .....	30
2. (TX) Transmitting .....	30
3. (HI/LO) TX Power .....	30
4. ATIS Active .....	30
5. (SAVED) Memory Mode .....	30
6. (LOCAL) Local/Distant Mode .....	31
7. (FAV123) Favorite Channel .....	31
8. Automatic Channel Changing Blocked .....	31
9. GPS .....	31
10. DSC Call .....	31
11. Weather Alert .....	31
12. Dot Matrix Display .....	31
13. (MAN) Manual Position Data .....	31
14. Channel Status .....	32
15. Soft Key Labels .....	32
16. Channel Name .....	32
17. Channel Number .....	32
18. Channel Set .....	32
19. Signal Strength .....	32
Display Mode .....	32
3.3 Alert Messages .....	33
3.4 Turning the Power ON and OFF .....	33
3.5 Setting the Volume .....	34
3.6 Setting the Squelch .....	34
3.7 Tuning the Channel .....	34
3.8 Selecting a Weather Channel .....	35
Weather Alert Operation .....	35

---

3.9	Selecting the Priority Channel .....	36
3.10	Selecting the Secondary Priority Channel .....	36
	Reprogramming the Secondary Priority Channel .....	36
3.11	Transmitting .....	37
	Overriding the Low Output Power Restriction .....	38
3.12	Menu Mode Operation .....	38
3.13	DSC Call Operation .....	38
<b>Chapter 4:</b>	<b>Menu Settings .....</b>	<b>39</b>
4.1	Menu Function .....	39
	Making Menu and Programming Selections .....	39
4.2	VHF Operations .....	42
	Scan Mode .....	42
	All Scan .....	43
	Priority All Scan .....	44
	Saved (Memory) Scan .....	44
	Priority Saved Scan .....	45
	Display Mode .....	45
	Setting the Power Output (HI/LO) .....	46
	Overriding the Low Output Power Restriction .....	47
	Saving Channels to Memory .....	48
	Using the Watch Modes .....	49
	Dual Watch .....	49
	Tri Watch .....	49
	Frequency Band .....	50
	Channel Name .....	51
	Favorite Channel .....	52
	Sensitivity .....	54
4.3	Hailer/Fog Horn/Intercom .....	54
	Hailer .....	54
	Fog Horn .....	55
	Intercom .....	55
4.4	GPS/Time Setup .....	57
	Manual Position .....	57
	Settings .....	58
	Latitude/Longitude Display .....	59
	Time Display .....	59
	Time Offset .....	59
	Time Format .....	59
	COG/SOG Display .....	59
	NMEA Output .....	60
4.5	System Configuration .....	62
	Backlight Adjustment .....	62

Contrast Adjustment .....	62
Key Beep .....	63
Signal Bar .....	63
Bearing Mode .....	63
Speed Unit .....	64
System Test .....	64
Version Number .....	65
Reset .....	65
VHF OPS .....	65
GPS SETUP .....	65
SYSTEM CONFIG .....	66
DSC MENU .....	66
<b>Chapter 5: Digital Selective Calling (DSC) .....</b>	<b>67</b>
5.1 DSC Call Menu .....	67
Making DSC Menu and Programming Selections .....	68
5.2 Distress Calls .....	70
Sending a Distress Call .....	70
Undesignated (Quick) Distress Call .....	70
Designated Distress Call .....	71
Transmitting .....	72
Receiving Acknowledgement .....	72
Cancelling a Distress Call Made in Error .....	72
Receiving a Distress Call .....	73
Receiving a Distress Relay Sent by Another Station .....	74
5.3 DSC Phonebook .....	74
Adding a new Entry .....	75
Editing an Existing Entry .....	76
Deleting an Existing Entry .....	77
5.4 Individual Calls .....	77
Making DSC Calls to Coast Stations .....	77
Transmitting an Individual Call .....	77
Receiving Individual Calls .....	79
5.5 Group Calls .....	81
Group MMSI Setup .....	81
Adding a New Group .....	81
Transmitting a Group Call .....	82
Receiving Group Calls .....	83
5.6 All Ships Calls .....	85
Transmitting an All Ships Call .....	85
Receiving an All Ships Call .....	86
5.7 Position Request .....	87
Specifying the Target Vessel .....	88

---

Retrieving the Last Received Position Data .....	89
Receiving a Position Request From Another Station .....	89
5.8 Received Calls (Logs) .....	90
Log Entry Options .....	91
5.9 DSC Setup .....	92
My MMSI ID .....	92
Position Reply .....	94
Automatic Channel Changing for Incoming Calls .....	95
<b>Chapter 6: Customer Service .....</b>	<b>97</b>
6.1 How to Contact Raymarine .....	97
On the Internet .....	97
Customer Support .....	97
Product Repair and Service .....	97
Accessories and Parts .....	98
Technical Support .....	98
<b>Appendix A: Specifications .....</b>	<b>99</b>
Generals .....	99
Transmitter .....	100
Receiver .....	100
<b>Appendix B: Radio Controls .....</b>	<b>101</b>
Microphone Keys .....	102
Transceiver Controls .....	102
Transceiver Push Keys .....	102
Optional RayMic Handset .....	103
RayMic Keys .....	104
<b>Appendix C: Menu Structure .....</b>	<b>105</b>
<b>Appendix D: Channel List .....</b>	<b>107</b>
U.S. Marine VHF Channels and Frequencies .....	107
Canadian Marine VHF Channels and Frequencies .....	110
International Marine VHF Channels & Frequencies .....	115
WX Channels (North America only) .....	118
<b>Appendix E: Glossary .....</b>	<b>119</b>
<b>Index .....</b>	<b>121</b>





# About this Handbook

## Intended Use

This handbook describes the Ray218 and Ray55 fixed VHF marine radios. The Ray218 and Ray55 provide two-way communications on all US, Canadian and International marine channels and weather watch on ten weather channels. The Ray218 and Ray55 include equipment for Class "D" Digital Selective Calling (DSC).

## Conventions Used

Throughout this handbook, the dedicated (labelled) keys are shown in bold capitals (for example: **MENU/DSC**). The LCD indicators and functions are shown in normal capitals (for example: TX).

## Technical Accuracy

To the best of our knowledge, the information in this handbook was correct as it went to press. However, our policy of continuous product improvement and updating may change specifications without prior notice. As a result, unavoidable differences between the product and handbook may occur from time to time. Raymarine cannot accept liability for inaccuracies or omissions it may contain.

For the latest handbook revisions and product information visit our web site:

[www.raymarine.com](http://www.raymarine.com)

## Warranty

To register your new Raymarine product, please take a few minutes to fill out the warranty registration card found at the end of this handbook. It is very important that you complete the owner information and return the card to the factory in order to receive full warranty benefits.

## Important Information

Raymarine radios comply with the Federal Communications Commission (FCC) and Industry Canada requirements that regulate marine VHF radio usage for the US and Canada, respectively. Marine VHF radio users in the US must comply with all applicable FCC rules and regulations, some of which are described in this handbook.

This information was current at the time this handbook was printed. Up-to-date information, including licensing requirements, can be obtained on the FCC web site at:

[www.fcc.gov/wtb/marine](http://www.fcc.gov/wtb/marine)

Official FCC forms can be obtained on the FCC web site at:

[www.fcc.gov/formpage.html](http://www.fcc.gov/formpage.html)

## FCC Notice

This device complies with part 15 of the FCC Rules. Operation is subject to the following two conditions: (1) This device may not cause harmful interference, and (2) this device must accept any interference received, including interference that may cause undesired operation.

Changes or modifications to this equipment not expressly approved in writing by Raymarine, Incorporated could violate compliance with FCC rules and void the operator's authority to operate the equipment.

## Station License

An FCC Ship Radio Station License and Call Sign are not required for most recreational vessels travelling in US waters. However, you must obtain a license if your vessel travels to foreign ports.

Ships that use MF/HF single side-band radio, satellite communications, or telegraphy must be licensed by the FCC. You can obtain a Station License by filing FCC Form 605, which is available from the FCC web site listed above.

## Operator License

An Operator License is not required to operate a VHF Marine Radio within US territorial waters. However, a license is required to operate the radio if you dock in a foreign port (including Canada and Mexico) or leave a foreign port to dock in a U.S. port. You can request a Restricted Radiotelephone Operator Permit from the FCC by filing Form 753.

## INDUSTRY CANADA

You do not need a license to operate this radio within sovereign waters of Canada or the US. You will need a license to operate this radio outside of Canada or the US. To obtain Industry Canada licensing information, contact the nearest field or regional office, or write:

Industry Canada  
Radio Regulatory Branch  
Attention: DOSP  
300 Slater Street  
Ottawa, Ontario  
Canada, K1A 0C8

The following information about the radio is required to complete the license application:

Industry Canada Certification Number: 4069A-VHFGEN1  
FCC Type Number: PJ5VHFGEN1  
FCC Type Accepted: Parts 15 and 80  
Output Power: 1 watt (low) & 25 watts (high)  
Modulation: FM (16K0G3E), DSC (16K0G2B)  
Frequency Range: 156.025–157.425

## Maritime Mobile Service Identity (MMSI)

The Ray218 and Ray55 include equipment for Class "D" Digital Selective Calling (DSC). A nine-digit Maritime Mobile Service Identity (MMSI) number is required to operate the DSC equipment.

You can request an MMSI number from the FCC when you apply for a Station License. If your vessel does not require a license, you may obtain an MMSI by contacting BoatUS ([www.boatus.com](http://www.boatus.com)). Once obtained, you can program the MMSI number into your Ray218/Ray55 as described in this handbook.

## Safety Notices

Your Raymarine VHF radio generates and radiates radio frequency (RF) electromagnetic energy (EME). This equipment must be installed and operated in accordance with the instructions contained in this handbook. Failure to do so can result in personal injury and/or product malfunction.

## Antenna Mounting and EME Exposure

This system has a Maximum Permissible Exposure (MPE) Radius of 1.5 meters (per OET Bulletin 65), assuming the maximum power of the radio and antennas with a maximum gain of 3dBi. Accounting for the height of an average adult (2 meters) the minimum height of the antenna above the deck to meet RF exposure compliance requirements is 3.5 meters. Do not transmit when anyone is within the MPE radius of the antenna, unless shielded from the antenna field by a grounded metallic barrier.

**WARNING: Maximum Permissible Exposure**  
**Failure to observe these guidelines may expose those within the maximum permissible exposure (MPE) radius to RF radiation absorption that exceeds the FCC MPE limit. It is the operator's responsibility to ensure that no one comes within this radius.**

For optimal radio performance and minimal human exposure to radio frequency electromagnetic energy, make sure the antenna is:

- connected to the radio before transmitting
- located where it will be away from people
- located at least 1.5 meters (5 feet) from the radio's transceiver

## Safe Compass Distance

Safe Compass Distance is 1 meter for a common compass. To be sure, you should locate the radio as far as possible from the compass. Test your compass to verify proper operation while the radio is also operating.

## EMC Conformance

All Raymarine equipment and accessories are designed to the best industry standards for use in the recreational marine environment. Their design and manufacture conform to the appropriate Electromagnetic Compatibility (EMC) standards but correct installation and use is required to ensure that performance is not compromised.

# Chapter 1: Introduction

## 1.1 Ray218 and Ray55 Fixed Station VHF Radios

The Ray218 and Ray55 marine VHF radiotelephones are microprocessor-controlled transceivers that provide reliable simplex (single frequency) and semi-duplex (two frequency) communications. This handbook describes the physical and functional characteristics of these radios.



The Ray218 and Ray55 provide two-way communications on all US, Canadian and International marine channels and ten weather channels. Refer to the Frequency Tables in Appendix D, which list all marine VHF channels available in your radio. You should familiarize yourself with these tables to ensure proper channel usage.

## 1.2 Features

The Ray218 and Ray55 are designed and manufactured to provide ease of operation with excellent reliability. The Ray218 and Ray55 have many enhanced features, including:

- Waterproof to IPX-7 standard
- Anti-glare 1.9" (48mm) x 1.3" (32mm) LCD full dot matrix display
- 3 soft keys for easy programming and menu selection

- 10 Weather Channel watch with 1050Hz Alert Tone detect
- Dedicated key for switching to Priority Channel 16
- Programmable Secondary Priority Channel key
- All Scan, Memory Scan and 2 Priority Scan functions
- Dual/Tri Watch Monitor modes
- Local Mode decreases noise in areas where RF interference is high
- Enhanced GPS Position Data gives Latitude and Longitude to 1/10,000 of a minute plus Time, SOG and COG data from any NMEA input
- Automatically distinguishes between calls made to Ship or Coast Stations
- Low and High Voltage detection with alarm
- Editable Channel Name
- 10 Brightness and Contrast settings
- Optional RayMic Second Station Handset

## Digital Selective Calling (DSC)

The Ray218 and Ray55 include equipment for Class "D" Digital Selective Calling (DSC). DSC protocol is a globally applied system used to send and receive digital calls. DSC uses a unique Maritime Mobile Service Identity (MMSI) number to direct DSC calls directly to your radio, much like a telephone number. Most importantly, DSC enables digital distress calls that automatically notify other ships and shore stations where you are and that you are in a distress situation.

**Note:** An MMSI ID number is required to operate the DSC equipment in this radio. You can obtain an MMSI from BoatUS ([www.boatus.com](http://www.boatus.com)). Once obtained, you can program the MMSI number yourself one time only using the menu operation described in "My MMSI ID" on page 92.

The Ray218 and Ray55 include the following DSC features:

- Separate receiver dedicated to handling DSC Calls on channel 70
- Position Request function sends GPS position data to or receives position data from other stations
- Phonebook for automatically making DSC calls
- Quick Save feature saves incoming DSC Calls and the caller's associated MMSI number directly into the phonebook
- Quick Call feature sends Individual Calls or Group Calls directly from the phonebook, just like the redial function on a telephone
- Five Group IDs for making DSC Calls only to stations in your group, such as a flotilla or fishing fleet

DSC functions are fully described in Chapter 5.

# Chapter 2: Installation

## 2.1 Unpacking and Inspection

Use care when unpacking the unit from the shipping carton to prevent damage to the contents. It is also good practice to save the carton and the interior packing material in the event you must return the unit to the factory.

### Equipment Supplied

The following is a list of materials supplied with the Ray218 and Ray55:

<b>Part No</b>	<b>Description</b>
<b>E43032</b>	<b>Ray218 VHF Radio with removable microphone</b>
R49163	Sun Cover for Ray218
R49164	Mounting Bracket for Ray218
R49165	Bracket Knob for Ray218/Ray55/Ray49
R49171	Microphone for Ray218
R49166	Microphone Hanger for Ray218/Ray55/Ray49
R49167	Power Cord for Ray218/Ray55/Ray49
R49168	NMEA/Speaker/Hailer Cable for Ray218
81278	Handbook for Ray218/Ray55
	Screws (x5) for Mounting Bracket/Microphone Hanger
	Screw/Lock Washer (x1) for Grounding
<b>E43036</b>	<b>Ray55 VHF Radio with integral microphone</b>
R49170	Sun Cover for Ray55
R49169	Mounting Bracket for Ray55
R49165	Bracket Knob for Ray218/Ray55/Ray49
R49166	Microphone Hanger for Ray218/Ray55
R49167	Power Cord for Ray218/Ray55/Ray49
81278	Handbook for Ray218/Ray55
	Screws (x5) for Mounting Bracket/Microphone Hanger
	Screw/Lock Washer (x1) for Grounding

The following is a list of optional equipment:

<b>Part No</b>	<b>Description</b>
A46051	RayMic Second Station for Ray218/Ray55
A46055	RayMic Extension Cable, 5m
A46056	RayMic Extension Cable, 10m
A46054	Microphone Relocation Kit for Ray218/Ray55
A46053	Rear Flush Mount Kit for Ray218/Ray55
A46060	Front Flush Mount Kit for Ray218
E46006	10W External Speaker
M95435	Hailer Horn Speaker

## 2.2 Planning the Installation

Mount the transceiver to allow easy access from the location where the boat is normally navigated. Select a location that is non-metallic, dry, protected, well-ventilated, and free from high operating temperatures and excessive vibration. Provide sufficient space behind the transceiver to allow for proper cable connections to the rear panel connectors. Locate the transceiver as near as possible to the power source yet as far apart as possible from any devices that may cause interference such as motors, generators, and other on board electronics. The radio should be protected from prolonged direct exposure to rain and salt spray.

The Ray218/Ray55 is not designed to be mounted in engine compartments. Do not install the radio in a location where there may be flammable vapors (such as in an engine room or compartment, or in a fuel tank bay), water splash or spray from bilges or hatches, where it is at risk from physical damage from heavy items (such as hatch covers, tool boxes, etc.), or where it might be covered by other equipment. Locate the radio at least 1.5 meters from the antenna.

Safe Compass Distance is 1 meter for a common compass. To be sure, you should locate the radio as far as possible from the compass. Test your compass to verify proper operation while the radio is also operating.

The Ray218/Ray55 can be conveniently mounted on a chart table, bulkhead, overhead, or any other desired location. Refer to the following figure for typical mounting methods.



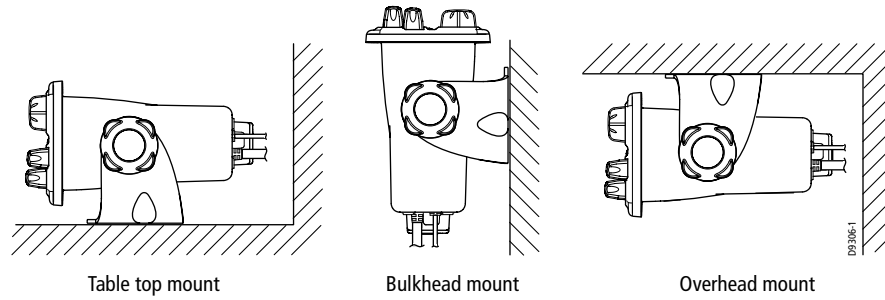

The Ray218/Ray55 may also be flush mounted using the optional E46034 Flush Mount Kit. Instructions for installing the radio using the Flush Mount Kit are included with the kit, available from your Raymarine dealer.

**Ray218 Dimensions**

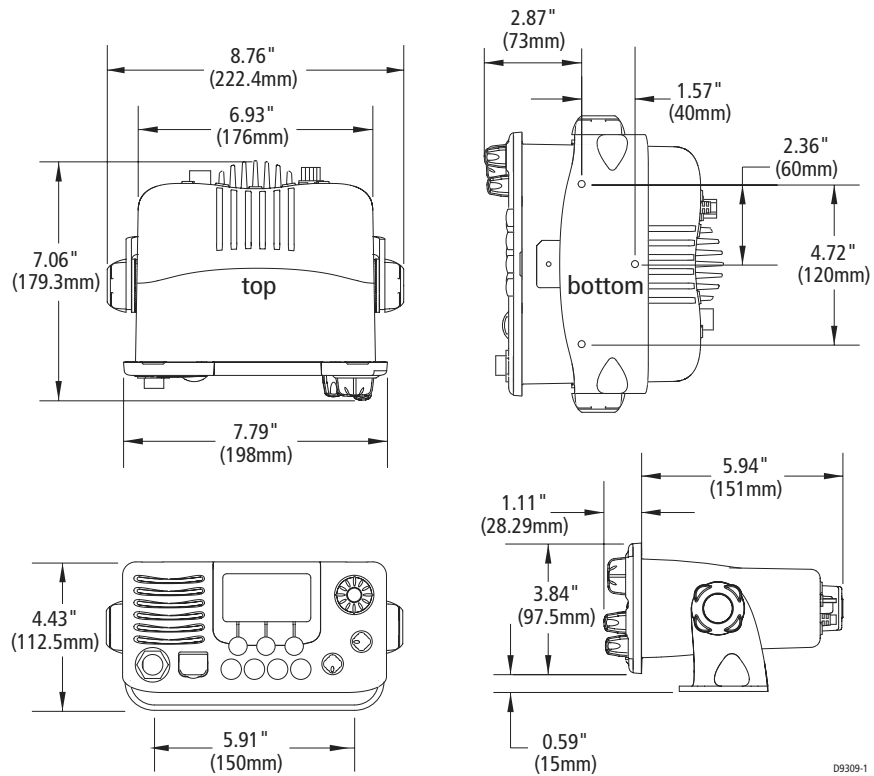

**Ray55 Dimensions**

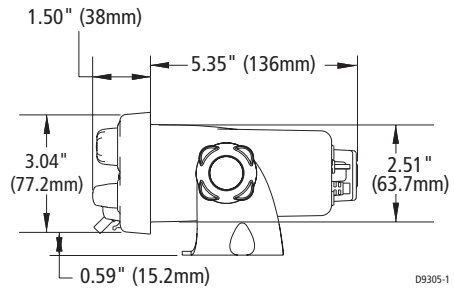
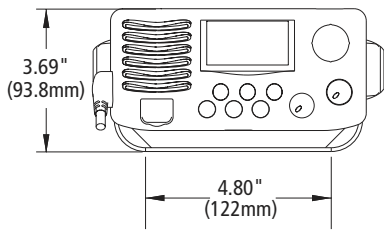
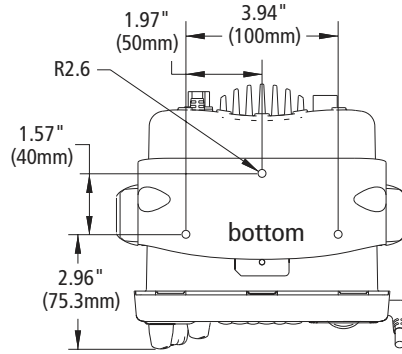
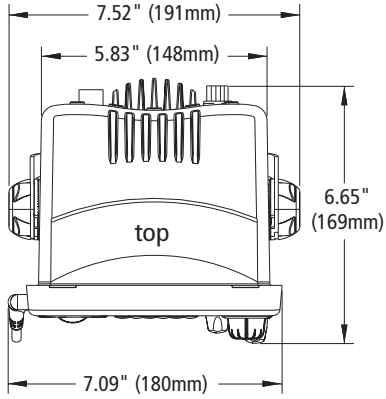

D9305-1

## 2.3 Cable Connections

The radio has bullet connectors for power and cable connectors for attaching the optional RayMic or Microphone Relocation Kit. The remaining wires are for attaching NMEA, and an optional external speaker or hailer horn. The Ray218 has a single cable with mating connectors for this purpose; the Ray55 has individual wire pairs. In either case, connect the wires as shown in the following table. Other connections are discussed in the ensuing sections.

Color	Signal	Connects to
Gray Purple	NMEA IN + NMEA IN –	GPS
Blue Brown	NMEA OUT + NMEA OUT –	Chartplotter display unit (E Series, C Series, etc.)
White Black	HAILER + HAILER –	Optional horn speaker, Raymarine part no. M95435
Yellow Green	SPEAKER + SPEAKER –	Optional remote speaker, Raymarine part no. E46006

Make cable connections as shown in the figures that follow.

### Ray218 Rear Connections

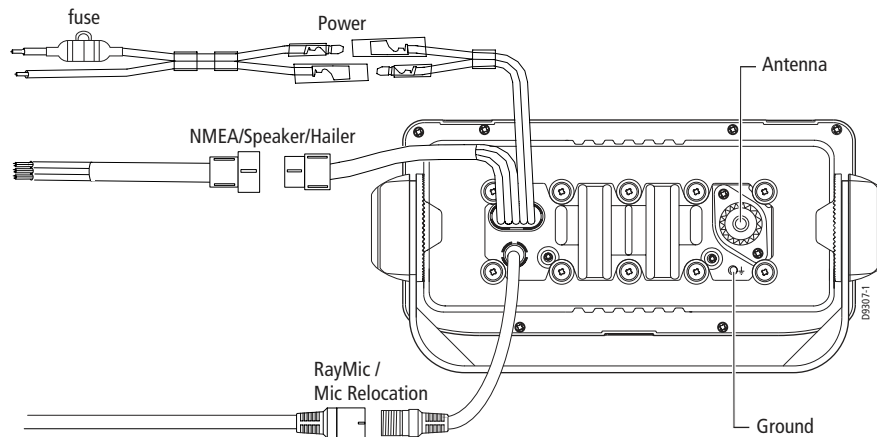

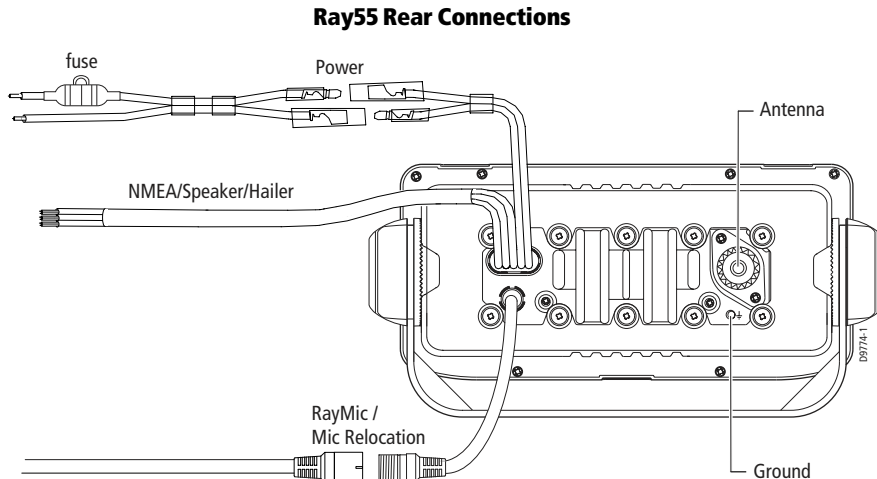



The ends of all wires are clipped at the factory so that no bare metal is exposed. You must strip back the insulation before installation. If you are not connecting a wire or set of wires (HAILER, for example), leave them insulated. If you have stripped back a wire that you will not be connecting, clip the bare wire down to the insulation.

## Power

The red and black Power Cord provides connection to DC power. Slide the bullet connectors on the cord into their mates (with the same colored wire) on the rear of the radio. The red (+) wire contains a 7 amp in-line fuse. It should be connected to the positive terminal of the power source. The black (-) wire should be connected to the negative (ground) of the power source. If the fuse ever needs to be replaced, be sure to use the same type and rating.

Connect the stripped wires on the Power Cord to the nearest primary source of the boat's DC power. A typical source would be a circuit breaker on the power panel or a fuse block near the unit. The circuit breaker or other in-line fuse should be rated at 10 amps. The power cord should be long enough to reach the DC power source. If additional wire length is required, the cable can be extended by adding more cable as necessary. However, for power cable runs longer than 15 feet, larger wire diameter size should be used to prevent voltage line loss. To ensure adequate current draw to the equipment, Raymarine recommends that you use lugs to connect the power cable to the DC supply and that the lug connections be both crimped and soldered.

The Ray218/Ray55 is designed to be operated on a 12 volt (nominal) system. If battery voltage drops below 10.5 VDC, the  LOW icon appears on the LCD. Discontinue using the radio if a low voltage condition occurs as performance would be unreliable. If voltage increases to 15.8 VDC,  HIGH appears. If voltage exceeds 18.5 VDC, the unit automatically shuts down to prevent damage to the equipment.

### RayMic / Mic Relocation

The radio has cable connectors for attaching either the optional RayMic or the Microphone Relocation Kit for mounting the microphone in a remote location. Align the arrows on both connector ends and mate.

### Hailer Horn

Connect the white (+) wire and black (-) wire to the hailer horn observing polarity as it is marked on the speaker.

**The HAILER – wire is the same color as the POWER – wire (black). Ensure that black HAILER – wire is NOT connected to ground or to the negative terminal of the boat’s battery.**

*Note: To avoid feedback, mount the horn so that it is facing away from the microphone and is located at least 3 meters (10 feet) from the microphone.*

### External Speaker

Connect the yellow(+) wire and green (-) wire to the speaker observing polarity as it is marked on the speaker.

### NMEA Data

The Ray218/Ray55 accepts NMEA 0183 (V3.01) data from a position determining device (GPS) to provide the Latitude and Longitude position information. This information appears on the radio’s LCD display and is also transmitted during a DSC Distress Call. When a valid NMEA signal is detected, the GPS satellite indicator appears on the LCD.

When Distress Call and Position (lat/lon) information is received from other stations, your Ray218/Ray55 also has the capability of outputting the vessel’s position to your chartplotter display unit (C Series, E Series, etc.) over the NMEA port so that it can be displayed on the screen. See “NMEA Output” on page 60 for details.



### NMEA IN (from GPS)

Connect the NMEA OUT + and NMEA OUT – signals from the positioning device to the NMEA IN + (gray) and NMEA IN – (purple) wires, respectively, from the radio. An example of how to make the connections using a suitable connector block is shown in the following drawing. For specific instructions how to connect your particular GPS, please refer to the handbook that came with that device.

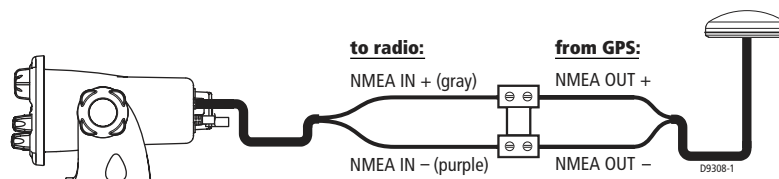

### NMEA Alarm

When no valid position data is available, the NMEA alarm sounds (provided that the MMSI number has been programmed): the GPS satellite icon flashes and NO POS DATA is displayed on the dot matrix display. The alert tone sounds for 5 seconds or until you acknowledge it by pressing any key. The alarm repeats every four hours, as long as the condition exists.

If desired, you can manually enter time and position data using the GPS/Time Setup feature, as described on page 57. The alert repeats every four hours as long as no position information has been entered manually. If position data is entered manually but has not been updated during the previous 23.5 hours, all the position (lat/lon) fields are set to all 9's, time field is set to all 8's, and the display reverts to NO POS DATA.

### NMEA OUT (to Chartplotter Display)

Connect the NMEA IN + and NMEA IN – signals from the chartplotter display to the NMEA OUT + (blue) and NMEA OUT – (brown) wires, respectively, from the radio. An example of how to make the connections using a suitable connector block is shown in the following drawing. For specific instructions how to connect your particular display, please refer to the handbook that came with that device.

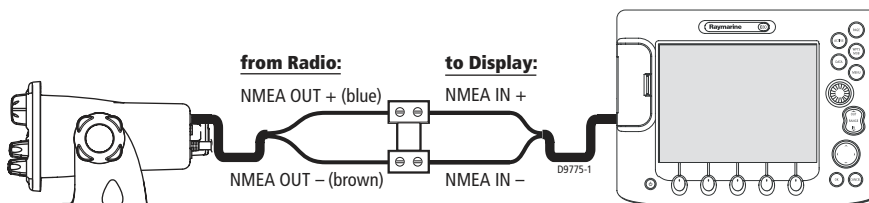

## Antenna

Raymarine recommends that you install a VHF Marine band antenna with a minimum height of 8 ft. and gain of at least 6 dB.

The coaxial VHF antenna cable connects to the Ray218/Ray55 antenna jack on the rear panel using a PL-259 VHF type connector. The antenna cable length can be critical to performance. If you are uncertain, contact a professional installer or call Raymarine Product Support. If a longer cable length is required, RG-8x (50 ohm) marine coaxial cable or equivalent cable can be used for runs up to a maximum of 50 feet. If the distance required is even greater, Raymarine recommends using low loss RG-213 or equivalent cable for the entire run to avoid excessive losses in power output.

If the antenna RF connector is likely to be exposed to the marine environment, a protective coating of silicon grease (Dow Corning DC-4 or similar) can be applied to the connector before connecting it to the radio. Any other extensions or adapters in the cable run should also be protected by grease and then wrapped with a waterproofing tape.

If the antenna is not properly connected to the radio, or if the antenna is faulty, the message ANT PROBLEM will appear. See "Alert Messages" on page 33.

### Antenna Mounting Suggestions

Mounting the VHF antenna properly is very important because it will directly affect the performance of your VHF radio. Use a VHF antenna designed for marine vessels. Since VHF transmission is essentially line-of-sight, mount the antenna at a location on the vessel that is free of obstruction to obtain maximum range.

If you must extend the length of the coaxial cable between the antenna and the radio, use a coaxial cable designed for the least amount of power loss over the entire cable length.

For optimal radio performance and minimal human exposure to radio frequency electromagnetic energy, make sure the antenna is:

- mounted as high as possible
- located where it will be away from people
- located at least 1.5 meters (5 feet) from the radio
- connected to the radio before transmitting

## Grounding

While special grounding is not generally required for VHF radiotelephone installations, it is good marine practice to properly ground all electronic equipment to the boat's earth ground system. The Ray218/Ray55 can be connected to ground by installing the supplied screw and lock washer into the threaded hole labelled with the  $\perp$  icon, located on the transceiver's rear panel, adjacent to the antenna jack. Then attach a #10 AWG wire from this screw to the nearest ship's earth ground connection point.

**CAUTION: Do not connect this ground connection to the negative terminal of the battery.**



# Chapter 3: General Operations

## 3.1 Keypad and Rotary Knobs

Several of the keys on the front panel of the transceiver serve multiple purposes. For the most part, the function indicated on the first line of the key is accessed by pressing that key for fewer than 3 seconds and then releasing it. The function indicated on the second line of the key is accessed by pressing and holding the key for greater than 3 seconds.

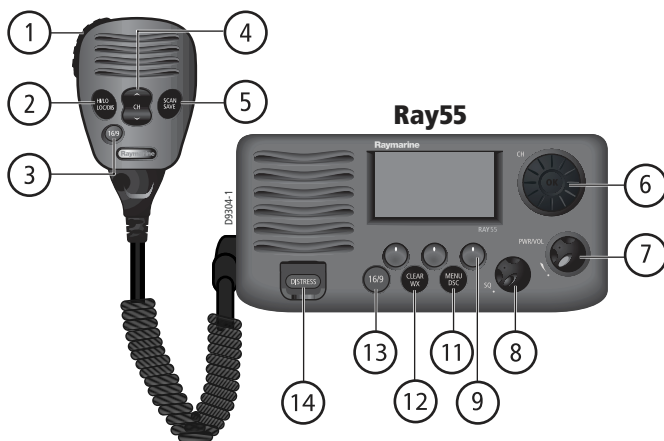
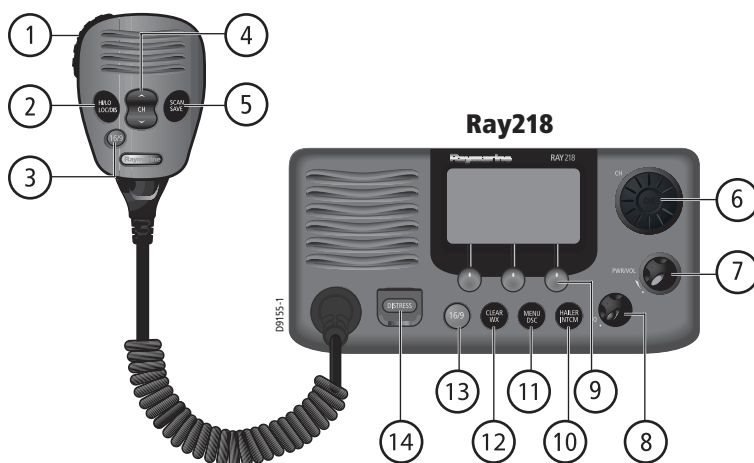

## Microphone Keys



### 1. PTT

Press this Push-to-Talk key to transmit.



### 2. HI/LO / LOC DIST

Press and release to toggle the transmit power from HI to LO. Can also be used to select items in menu mode. Press and hold for to toggle between full receiver sensitivity (Distant mode) and attenuated receiver sensitivity (Local mode).



### 3. 16/9

Use this key to switch to the priority channel or to change the value of the Secondary Priority Channel.



### 4. UP/DOWN

Use the arrow keys to change the active channel number. Press and hold for rapid channel changing. Can also be used to scroll through selections in menu and programming modes.



### 5. SCAN / SAVE

Press and release this key to access the Scan Mode menu, which is described on page 42. If Scan Mode is active, pressing this key terminates the scan. Press and hold for 3 seconds to enter a channel into the radio's memory. This function is described in "Saving Channels to Memory" on page 48.

## Transceiver Controls



### 6. CH/OK

Rotate this knob to change the current channel number and to change values in Menu mode or during programming. Press in to enter values selected in Menu mode or during programming.



### 7. PWR/VOL

Use this knob to turn the radio ON and OFF and to set the volume.



### 8. SQ

Use this knob to set the squelch threshold, which cuts off the receiver when the signal is too weak for reception of anything but noise.



### 9. Soft Keys

These multifunction keys change according to context, such as to navigate through menus or to make menu selections. Press to select the corresponding function as identified by the on-screen label.

## Transceiver Push Keys



### 10. HAILER / INTCM

Press and release to access the hailer horn to make voice announcements or sound various fog horn tones. Press and hold for 3 seconds to use the intercom feature to communicate with a secondary station. Requires an optional RayMic second station.

This key is only available with the Ray218.



### 11. MENU/DSC

Press and release this key to select Menu Mode, which is used to set up the radio. Menu operations are fully described in Chapter 4.

Press and hold for 3 seconds to enter DSC Call Mode, which is used for making DSC Calls and viewing the DSC Call Logs and the DSC Call Phonebook.

A Maritime Mobile Service Identity (MMSI) number is required to operate the DSC equipment in this radio. This number directs DSC calls directly to your radio, much like a telephone number. You can program the MMSI number yourself one time only using the operation described in "My MMSI ID" on page 92. Otherwise, your Raymarine dealer can program or change the number for you.

Full details on DSC call operation are described in Chapter 5.



### 12. CLEAR/WX

Press and release to terminate a function and return to the last-used channel. Press and hold for 3 seconds to select the Weather mode.



### 13. 16/9

Use this key to switch to the priority channel or to change the value of the Secondary Priority Channel.



### 14. DISTRESS

Push up the spring-loaded cover and press this key to make a DSC Distress Call. Instructions for making a Distress Call are described in Section 5.2.

## Optional RayMic Second Station

The optional RayMic Handset provides the Ray218/Ray55 with a second station in a telephone handset design. The RayMic, which attaches to the handset connector on the rear of the radio, enables intercom capabilities with the transceiver from a remote portion of the vessel. Intercom functions are discussed on page 55.



### A. PTT

Press this Push-to-Talk key to transmit.

### B. VOL/SQ

By default, these keys control earpiece speaker volume. Press the up arrow key to increase or the down arrow to decrease the volume.

Press and release the center key to activate the squelch threshold adjustment.

Then, press up arrow key to increase or down arrow to decrease the squelch level.

**C. CLEAR/WX**

Press and release to terminate a function and return to the last-used channel.  
Press and hold for 3 seconds to select the Weather mode.

**D. 16/9**

Press and release this key to switch between the Priority Channel 16 and the current working channel.

Press and hold for 3 seconds to tune to the Secondary Priority Channel, which defaults to 9.

If already tuned to the Secondary Priority Channel, press and hold for 3 seconds to program a new Secondary Priority Channel.

**E. Soft Keys**

These multifunction keys change according to context, such as to navigate through menus or to make menu selections. Press to select the corresponding function as identified by the on-screen label.

**F. MENU / DSC**

Press and release this key to select Menu Mode, which is used to set up the radio. The menu structure is outlined in the following drawing. Menu operations are fully described in Chapter 4.

Press and hold for 3 seconds to enter DSC Call Mode, which is used for making DSC Calls and viewing the DSC Call Logs and the DSC Call Phonebook.

**G. CH**

Use the arrow keys to change the active channel number. Press and hold for rapid channel changing. Can also be used to scroll through selections in menu and programming modes.

**H. OK / INTCM**

Press and release this key to enter values selected in Menu mode or during programming. Press and hold for 3 seconds to enable the intercom feature for communications between the transceiver and RayMic second station. Intercom functions are discussed on page 55.

## 3.2 Transceiver LCD

The following describes the function of the characters on the radio's LCD.

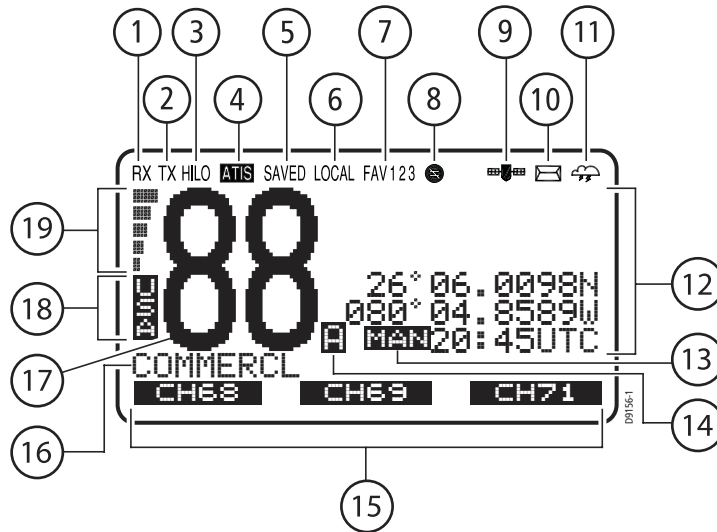

### 1. (RX) Receiving

Indicates that the radio is receiving a radio signal.

### 2. (TX) Transmitting

Indicates the **PTT** key is being pressed and the radio is transmitting.

### 3. (HI/LO) TX Power

Indicates whether transmit power is set for 25 watts (HI) or 1 watt (LO).

### 4. ATIS Active

Indicates ATIS transmission is enabled. Only available in European countries using the International channel set.

### 5. (SAVED) Memory Mode

Indicates the current channel has been saved in memory. Appears during Saved (Memory) Scan and Priority Saved Scan modes.

## 6. (LOCAL) Local/Distant Mode

Indicates the radio is in Local Reception mode, which decreases receiver sensitivity in high traffic areas to decrease unwanted reception.

## 7. (FAV123) Favorite Channel

Indicates which of the three (3) Favorite Channel banks is currently selected. Each bank displays a different favorite channel that you have assigned for each of the 3 soft key labels at the bottom of the LCD. This gives you a total of 9 favorite channels that you can jump to at the press of a key.

## 8. Automatic Channel Changing Blocked

Indicates that your radio will not automatically switch to the channel requested by an incoming DSC call but rather will prompt you to manually accept or decline the channel change request. Applies to Distress and All Ships Urgency calls only. This feature is controlled by the DSC Setup menu item POS REPLY, described on page 95. By default, this icon is off, meaning that auto channel changing is active.

## 9. GPS

Indicates that positional data is available from your GPS.

## 10. DSC Call

When flashing, indicates that the radio has received a DSC Call. Details of the call can be viewed in the associated log. See "Received Calls (Logs)" on page 90. The icon disappears when the call is accepted, the call is rejected, or the associated message is viewed in the log.

## 11. Weather Alert

Indicates that the radio is monitoring for weather alert broadcasts.

## 12. Dot Matrix Display

Indicates radio functions, GPS position data or special conditions, depending on the situation. The screen is different when sending/receiving a DSC Call (see Chapter 5) or setting up a Menu item (see Chapter 4).

## 13. (MAN) Manual Position Data

Indicates position data is not from GPS but rather has been entered manually.

## 14. Channel Status

A subscript character following the channel number indicates special qualities.

### (A) Simplex Channel

The subscript **A** indicates that the currently-selected US or Canadian channel is simplex, although its International counterpart is semi-duplex (5A, for example). This channel uses the transmit frequency of the International channel for both transmitting and receiving. If a channel is simplex in all 3 channel sets (US, Canadian, and International—channel 6, for example), the **A** does not appear.

**Note:** *Simplex means that the radio transmits and receives on the same frequency for this channel. Semi-duplex channels use separate frequencies to transmit and receive.*

### (B) Receive-only Channel

The subscript **B** indicates that you cannot transmit on the currently-selected channel; it is receive-only. Used with Canadian channels only.

## 15. Soft Key Labels

Displays the current function of the associated soft key.

## 16. Channel Name

Displays the current channel name. This field is editable.

## 17. Channel Number

Displays the current active channel number.

## 18. Channel Set

Indicates which channel set is selected: USA, INT (International), CAN (Canadian), or WX (Weather).

## 19. Signal Strength

Indicates that the relative strength of the radio signal being received. Displays between 0 (no signal) and 5 (strongest signal) bars.

## Display Mode

The Ray218/Ray55 has an alternative method for displaying the channel number than the one demonstrated above: 2 UP mode. In 2 UP mode, you are presented with the currently-active channel on the left and the standby channel on the right. 2 UP mode is discussed in "Display Mode" on page 45.



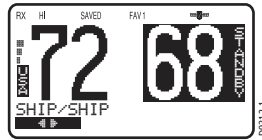

### 3.3 Alert Messages

The radio has several warning messages to alert you to special conditions.

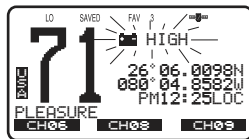

#### Battery Voltage High

Indicates boat's battery voltage exceeds 15.8 VDC (typical). If voltage exceeds 18.5 volts (typical), the radio powers itself off to prevent equipment damage.

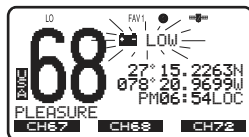

#### Battery Voltage Low

Indicates boat's battery voltage is below 10.5 VDC (typical), which is the lowest voltage at which the radio can be reliably operated.

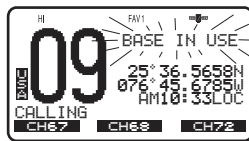

#### Base in Use

Indicates that the base station (transceiver) is in use and has priority. Only appears on a RayMic second station when the transceiver is already in use.

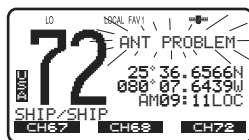

#### Antenna Problem

Indicates that the antenna is not properly connected or is faulty.

### 3.4 Turning the Power ON and OFF



Turn the **PWR/VOL** knob clockwise until it clicks. When the unit powers up in standby mode it:

- Beeps, illuminates the backlight at full brightness, and displays a self-test.
- Recalls the last CH number, TX power settings and operation mode. If no last-used setting data exists, goes to CH 16 and high TX Power.
- When GPS Data is available, extended position data is displayed with the off-set time. This information will be displayed when display option for the position and time is enabled on the Menu. See Section 4.4.

- When the MMSI number is not programmed, you are prompted to enter the number as described on page 92. You must then press OK to continue.

To turn the unit OFF, rotate the **PWR/VOL** knob completely counterclockwise until it clicks.

### 3.5 Setting the Volume



#### ...on the Transceiver

Adjust the **PWR/VOL** knob to control the loudspeaker volume level. Turn clockwise to increase the volume; counter clockwise to decrease the volume.

#### ...on the optional RayMic



Press the up arrow on the **VOL/SQ** key to increase or the down arrow to decrease the volume level.

### 3.6 Setting the Squelch

The squelch circuit sets the threshold for cutting off the receiver when the signal is too weak for reception of anything but noise.



#### ...on the Transceiver

To properly set the squelch, rotate the **SQ** knob counterclockwise until audio is heard. Then rotate clockwise until background noise disappears.

#### ...on the optional RayMic



Press and release the center of the **VOL/SQ** key to activate squelch threshold level adjustment. Press the down arrow key until audio is heard. Then press the up arrow until background noise disappears.

### 3.7 Tuning the Channel



#### ...on the Transceiver

Rotate the **CH** knob clockwise to increase the channel number.

Rotate the **CH** knob counterclockwise to decrease the channel number.

#### ...on the optional RayMic



Press and release the UP arrow to increase the channel number.

Press and release the DOWN arrow to decrease the channel.

Press and hold either key for rapid channel scrolling.

### 3.8 Selecting a Weather Channel



The US National Oceanic and Atmospheric Administration (NOAA) broadcasts continuous weather reports and severe weather alerts, as needed. The Ray218/Ray55 is programmed to receive 10 weather channels and sound an alarm if a weather alert is received.

To enter Weather mode, press and hold the **CLEAR/WX** key for 3 seconds on either the transceiver or the RayMic.

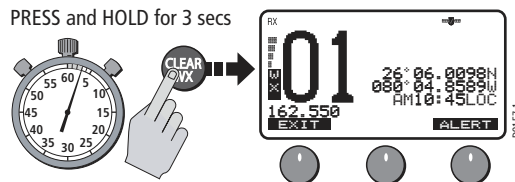

The weather function soft keys appear and the WX indicator appears in the channel set field. Rotate the **CH** knob on the transceiver or use the channel up / down keys on the RayMic to select from channels WX01 through WX10.

Press and release the **CLEAR/WX** key again to return to normal operation.

#### Note:

1. WX broadcasts can only be heard in the US and Canada.
2. During Weather mode, the PTT, HI/LO, and SCAN/SAVE keys are disabled and an error beep sounds if pressed.

### Weather Alert Operation

NOAA also broadcasts continuous severe weather alerts as needed. You can set your Ray218/Ray55 to notify you when such an alert is issued. To enable the Weather Alert, press the ALERT soft key. The cloud icon appears.

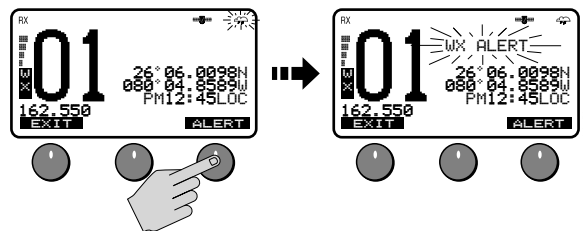

When the severe weather alert tone is detected, the message WX ALERT is displayed and an alarm sounds. The radio automatically tunes to the WX channel where the weather alert has been detected. The alert is detected in all modes of operation (Standby, Dual Watch, Tri Watch, Scan, etc.)

### 3.9 Selecting the Priority Channel

**16/9** The Ray218/Ray55 provides you with a dedicated key for switching to the Priority Channel 16. Press and release the **16/9** key to switch to CH16 at high power. The label 1ST PRIORITY appears. If already on CH 16, press and release **16/9** to return to the last-used working channel.

The **16/9** key also can be used to cancel all other modes and switch to CH 16.

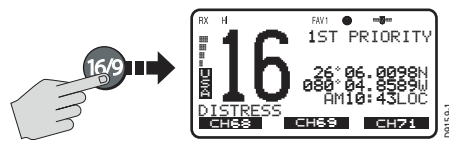

**Note:** When the priority channel is selected, the radio is always set to HIGH transmit power. You may reduce power if desired using the HI/LO power setting.

### 3.10 Selecting the Secondary Priority Channel

**16/9** The Ray218/Ray55 enables you to program the **16/9** key to store a Secondary Priority Channel. The default is CH 9. If on primary Priority CH16 or a working channel, press and hold the **16/9** for 3 seconds to switch to the Secondary Priority Channel at high power. The label 2ND PRIORITY appears. The default is CH 9.

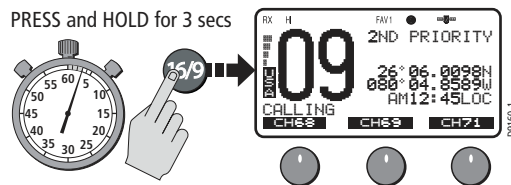

If already tuned to the Secondary Priority Channel, press and release the **16/9** key to switch to Priority Channel 16 at high power.

### Reprogramming the Secondary Priority Channel

1. Press and hold the **16/9** key for 3 seconds to switch to the current Secondary Priority Channel.
2. Press and hold the **16/9** key for 3 seconds again to switch to Reprogram mode. The message CHG 2ND PRI? appears with YES highlighted.
3. Press SELECT soft key to accept. The confirmation message CHANGE 2ND PRIORITY CH appears.
4. Rotate the **CH** knob until the desired new secondary channel is shown.
5. Press the OK soft key to accept the new Secondary Priority selection.

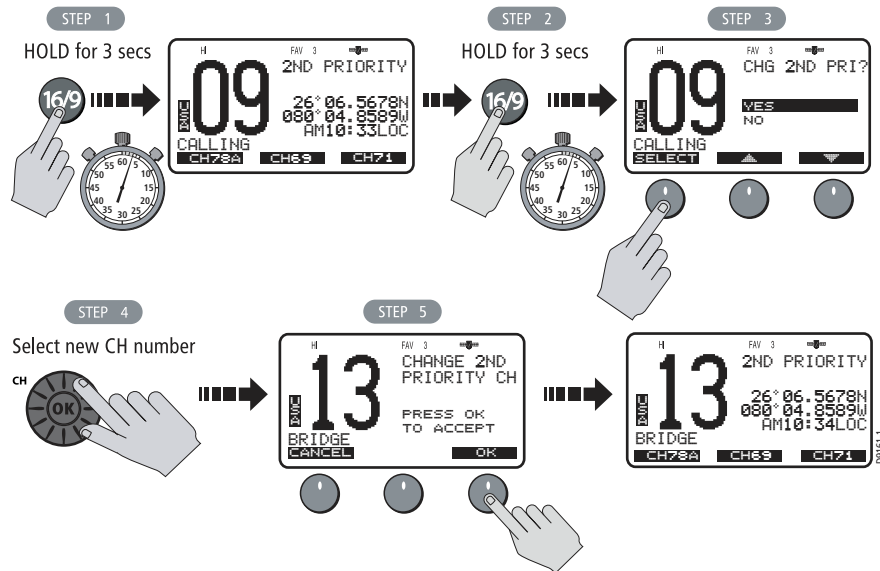

### 3.11 Transmitting



Press and hold the Push-to-Talk (**PTT**) key on the microphone to transmit on the selected channel, and then release to receive. The TX indicator appears during transmission.

**Note:** *International regulations and good communications practice dictate that you not interfere with other communications. Before transmitting, listen to make sure the channel is clear.*

The radio is equipped with a timeout timer in the event of a stuck key. After **PTT** has been held continuously for 5 minutes, transmission is discontinued, the message TX TIMEOUT appears, and the radio automatically returns to receive mode.

After the timeout, the alarm continues to sound until **PTT** is released. The TX time out timer is reset once the **PTT** key is released.

**Note:** *If the current channel is receive-only, an alert tone sounds when PTT is pressed, indicating such a transmission is not permitted.*

### Overriding the Low Output Power Restriction

In the US, channels 13 and 67 are restricted to transmit at low power. However, you can temporarily override this low power restriction. When you press **PTT**, a new soft key appears in the middle position, labelled **OVRIDE**.

To override the LO power restriction on channels 13 or 67 and transmit at high power:

1. Press and hold **PTT**. The **OVRIDE** soft key appears.
2. Press and release **OVRIDE**. The TX power is set to HI power for as long as you hold down **PTT**.

When you release **PTT**, power returns to LO.

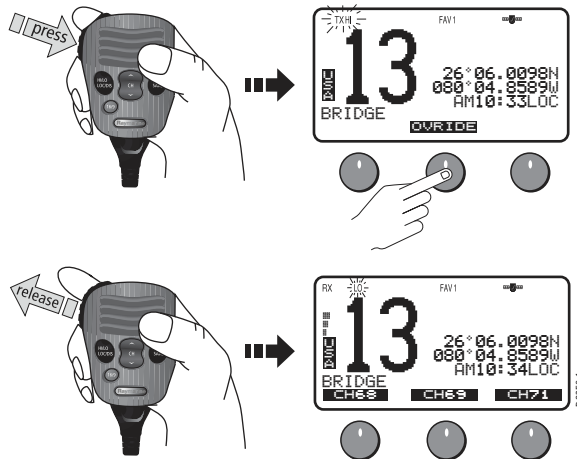

### 3.12 Menu Mode Operation



Press and release the **MENU/DSC** key while in standby mode to enter Menu Mode.

Menu mode is fully described in Chapter 4.

### 3.13 DSC Call Operation



Press and hold the **MENU/DSC** key for greater than 3 seconds while in standby operation mode to enter DSC Call Mode.

DSC Call mode is fully described in Chapter 5.

# Chapter 4: Menu Settings

## 4.1 Menu Function



Most of the radio's functions reside in the Main Menu, which is accessed through the **MENU/DSC** key. A diagram of the menu structure can be found in Appendix C.

### Making Menu and Programming Selections

There are three ways to make menu and character selections in your radio:

1. Most examples in this chapter describe making selections using the **CH** knob and soft keys on the transceiver.
2. However, you can also press the microphone up/down keys to make your selections and then press the microphone **HI/LO** key to accept.

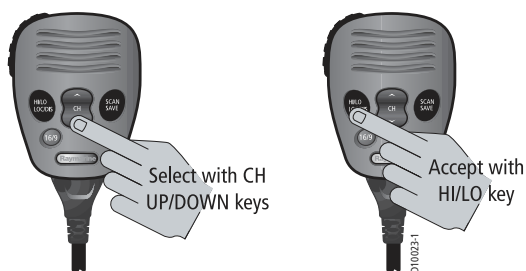

3. Alternatively, if you have an optional RayMic, you can use its **CH** up/down keys to select and **OK** key to accept.

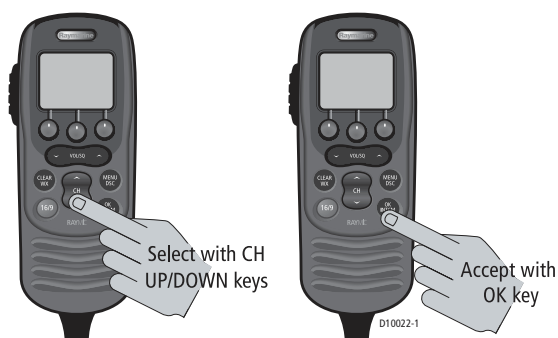

### To make Menu selections:

1. Press and release the **MENU/DSC** key to enter Menu mode. The list of available menu groups appears.



2. Use the up/down arrow soft keys or **CH** knob on the transceiver or **CH** up/down key on microphone (or RayMic) to scroll through the list until the desired menu is highlighted.

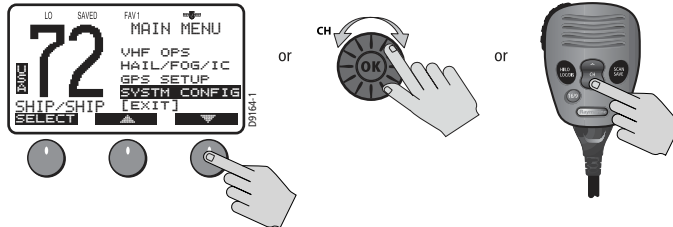

3. Press **SELECT** or the **CH** knob on the transceiver or **HILO** key on microphone (or **OK** key on RayMic) to accept. The sub-menu headings are displayed.

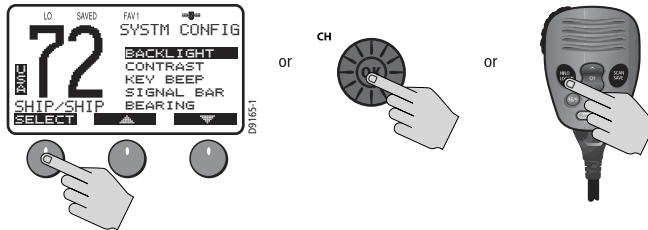

4. Use the up/down arrow soft keys or the **CH** knob on the transceiver or **CH** up/down key on microphone (or RayMic) to highlight the desired sub-menu.

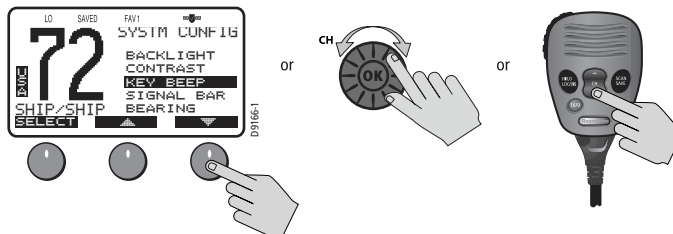



- Press **SELECT** or the **CH** knob on the transceiver or **HILO** key on microphone (or **OK** key on RayMic) to accept. The options under that sub-menu are displayed.

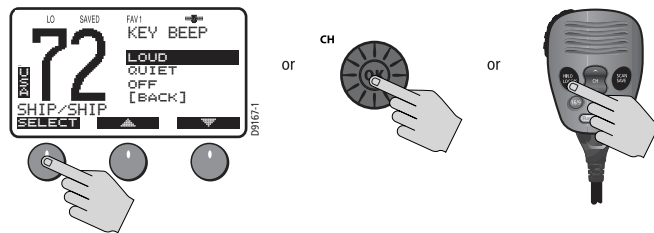

- Use the up/down arrow soft keys or the **CH** knob on the transceiver or **CH** up/down key on microphone (or RayMic) to highlight the desired option.

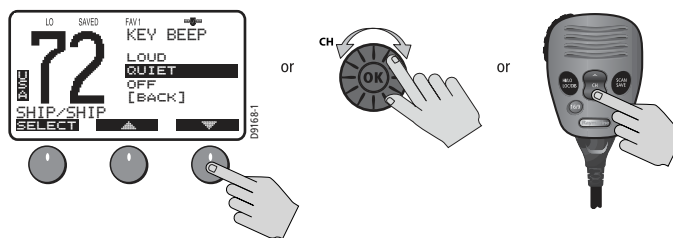

- Press **SELECT** or the **CH** knob on the transceiver or **HILO** key on microphone (or **OK** key on RayMic) to accept. The setting is changed. Continue in the same manner to make any other setting changes.

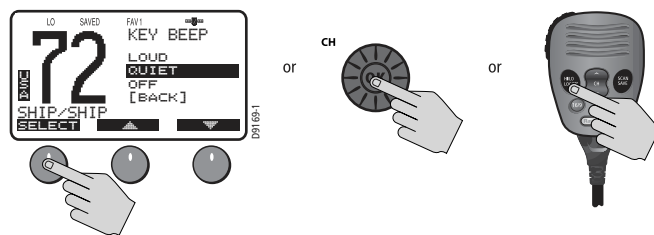

To return to the previous menu level, select the **[BACK]** menu option or press the **CLEAR/WX** key.

To exit the Menu mode, press the **CLEAR/WX** key again or else press the **16/9** key to switch to the priority channel in standby mode.

## 4.2 VHF Operations

This menu group controls basic radio functions. You access VHF Operations via the **MENU** key.

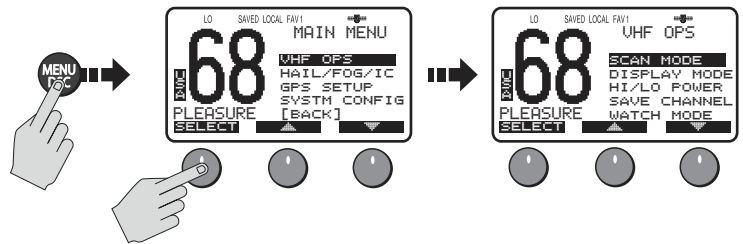

### Scan Mode

This function automatically searches through all channels in the set for any that are broadcasting. If a transmission is received, the scan stops on the receiving channel as long as it is present. If the signal is lost for five seconds, the radio resumes scanning.

If you wish to temporarily remove a received channel from the scan so that the scan no longer stops on this channel, press the **XCLUDE** soft key. The selected channel is only excluded for the time you are currently in scan mode.



You can directly access the Scan Mode menu by pressing and releasing the **SCAN/SAVE** key on the microphone. When a Scan Mode is active, you can terminate the scan and return the radio to standby mode by pressing and releasing the key again.

While scanning, press the microphone or RayMic **CH** up/down keys or rotate the **CH** knob on the transceiver to change the scan direction. UP (key)/clockwise (**CH** knob) increases the channel while DOWN (key) /counter-clockwise (**CH** knob) decreases it.

Your Ray218/Ray55 is equipped with four types of scan options: All Scan, Saved (Memory) Scan, Priority All Scan and Priority Saved Scan. The following illustration demonstrates how to initiate All Scan but the procedure is the same for all scan mode options.

**Note:** *Whenever Weather Alert is activated, the WX Alert channel is also monitored during the Scan Modes. If the WX Alert tone is detected, the scan is halted to receive the Weather Alert broadcast.*

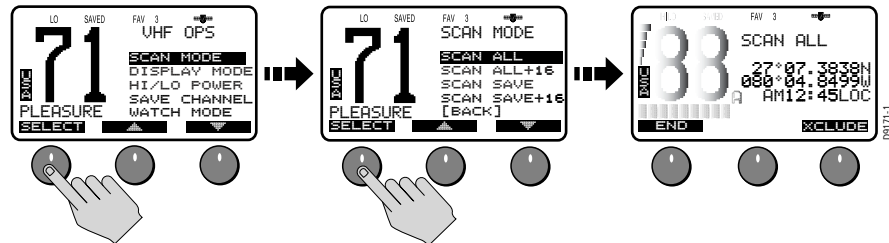

To *terminate* the SCAN mode and return to standby mode, press:

- END soft key
- **SCAN/SAVE** key on the microphone
- **CLEAR/WX** key on the transceiver
- **CLEAR/WX** key on the optional RayMic

### All Scan

In All Scan mode, all channels in the channel set are scanned in sequence. After the last channel number has been scanned, the cycle repeats.

When active, SCAN ALL appears on the display.

