

# a9x / a12x

**EN** Mounting and Getting Started

**ENGLISH**

Date: 05-2014

Document number: 88032-1-EN

© 2014 Raymarine UK Limited

INNOVATION • QUALITY • TRUST

**Raymarine®**

**ENGLISH**

Document number: 88032-1

Date: 05-2014

## Important information

### Certified Installation

Raymarine recommends certified installation by a Raymarine approved installer. A certified installation qualifies for enhanced product warranty benefits. Contact your Raymarine dealer for further details, and refer to the separate warranty document packed with your product.



### Warning: Read the expanded handbook

This document is an abbreviated ("quick start") handbook, containing only the basic information required to get you started with your new product. For the complete documentation and safety information for your product, please refer to the expanded handbook, available on the Raymarine website ([www.raymarine.com](http://www.raymarine.com)).



### Warning: Product installation and operation

This product must be installed and operated in accordance with the instructions provided. Failure to do so could result in personal injury, damage to your vessel and/or poor product performance.



### Warning: Potential ignition source

This product is NOT approved for use in hazardous/flammable atmospheres. Do NOT install in a hazardous/flammable atmosphere (such as in an engine room or near fuel tanks).



### Warning: High voltages

This product contains high voltages. Do NOT remove any covers or otherwise attempt to access internal components, unless specifically instructed in this document.



### Warning: Product grounding

Before applying power to this product, ensure it has been correctly grounded, in accordance with the instructions in this guide.



### Warning: Switch off power supply

Ensure the vessel's power supply is switched OFF before starting to install this product. Do NOT connect or disconnect equipment with the power switched on, unless instructed in this document.



### Warning: FCC Warning (Part 15.21)

Changes or modifications to this equipment not expressly approved in writing by Raymarine Incorporated could violate compliance with FCC rules and void the user's authority to operate the equipment.



### Warning: Radar scanner safety

Before rotating the radar scanner, ensure all personnel are clear.



### Warning: Radar transmission safety

The radar scanner transmits electromagnetic energy. Ensure all personnel are clear of the scanner when the radar is transmitting.



### Warning: Sonar operation

- NEVER operate the sonar with the vessel out of the water.
- NEVER touch the transducer face when the sonar is powered on.
- SWITCH OFF the sonar if divers are likely to be within 7.6 m (25 ft) of the transducer.



### Warning: Touchscreen display temperature

If the display is mounted where it will be exposed to prolonged periods of direct sunlight, the touchscreen may get very hot due to the absorbed solar energy.

In such conditions Raymarine highly recommends that you avoid using the touchscreen:

- For HybridTouch displays, use the integrated keypad to operate the display.
- For touch-only systems it is recommended that an external keypad is fitted to the system (for example, the RMK-9 accessory).



### Warning: Touchscreen display

Exposure to prolonged rain may cause erroneous touch performance, in these situations keep touch activity to a minimum and wipe the screen with a dry non-abrasive cloth before using the touchscreen.

### Caution: Transducer cable

- Do NOT cut, shorten, or splice the transducer cable.
- Do NOT remove the connector.

If the cable is cut, it cannot be repaired. Cutting the cable will also void the warranty.

### Caution: Power supply protection

When installing this product ensure the power source is adequately protected by means of a suitably-rated fuse or automatic circuit breaker.

### Caution: Care of chart and memory cards

To avoid irreparable damage to and / or loss of data from chart and memory cards:

- DO NOT save data or files to a card containing cartography as the charts may be overwritten.
- Ensure that chart and memory cards are fitted the correct way around. DO NOT try to force a card into position.
- DO NOT use a metallic instrument such as a screwdriver or pliers to insert or remove a chart or memory card.

### Caution: Ensure card reader door is securely closed

To prevent water ingress and consequent damage to the product, ensure that the card reader door is firmly closed.

### Caution: Cleaning

When cleaning this product:

- Do NOT wipe the display screen with a dry cloth, as this could scratch the screen coating.
- Do NOT use abrasive, or acid or ammonia based products.
- Do NOT use a jet wash.

### TFT Displays

The colors of the display may seem to vary when viewed against a colored background or in colored light. This is a perfectly normal effect that can be seen with all color Thin Film Transistor (TFT) displays.

### Water ingress

Water ingress disclaimer

Although the waterproof rating capacity of this product meets the stated IPX standard (refer to the product's *Technical Specification*), water intrusion and subsequent equipment failure may occur if the product is subjected to commercial high-pressure washing. Raymarine will not warrant products subjected to high-pressure washing.

### Disclaimers

This product (including the electronic charts) is intended to be used only as an aid to navigation. It is designed to facilitate use of official government charts, not replace them. Only official government charts and notices to mariners contain all the current information needed for safe navigation, and the captain is responsible for their prudent use. It is the user's responsibility to use official government charts, notices to mariners, caution and proper navigational skill when operating this or

any other Raymarine product. This product supports electronic charts provided by third party data suppliers which may be embedded or stored on memory card. Use of such charts is subject to the supplier's End-User Licence Agreement included in the documentation for this product or supplied with the memory card (as applicable).

Raymarine does not warrant that this product is error-free or that it is compatible with products manufactured by any person or entity other than Raymarine.

This product uses digital chart data, and electronic information from the Global Positioning System (GPS) which may contain errors. Raymarine does not warrant the accuracy of such information and you are advised that errors in such information may cause the product to malfunction. Raymarine is not responsible for damages or injuries caused by your use or inability to use the product, by the interaction of the product with products manufactured by others, or by errors in chart data or information utilized by the product and supplied by third parties.

### EMC installation guidelines

Raymarine equipment and accessories conform to the appropriate Electromagnetic Compatibility (EMC) regulations, to minimize electromagnetic interference between equipment and minimize the effect such interference could have on the performance of your system

Correct installation is required to ensure that EMC performance is not compromised.

**Note:** In areas of extreme EMC interference, some slight interference may be noticed on the product. Where this occurs the product and the source of the interference should be separated by a greater distance.

For **optimum** EMC performance we recommend that wherever possible:

- Raymarine equipment and cables connected to it are:
  - At least 1 m (3 ft) from any equipment transmitting or cables carrying radio signals e.g. VHF radios, cables and antennas. In the case of SSB radios, the distance should be increased to 7 ft (2 m).

- More than 2 m (7 ft) from the path of a radar beam.  
A radar beam can normally be assumed to spread 20 degrees above and below the radiating element.
- The product is supplied from a separate battery from that used for engine start. This is important to prevent erratic behavior and data loss which can occur if the engine start does not have a separate battery.
- Raymarine specified cables are used.
- Cables are not cut or extended, unless doing so is detailed in the installation manual.

**Note: Where constraints on the installation prevent any of the above recommendations, always ensure the maximum possible separation between different items of electrical equipment, to provide the best conditions for EMC performance throughout the installation**

**RF exposure**

This transmitter with its antenna is designed to comply with FCC / IC RF exposure limits for general population / uncontrolled exposure. The WiFi / Bluetooth antenna is mounted behind the front fascia on the left hand side of the screen. It is recommended to maintain a safe distance of at least 1 cm from the left hand side of the screen.

**FCC**

**Compliance Statement (Part 15.19)**

This device complies with Part 15 of the FCC Rules. Operation is subject to the following two conditions:

1. This device may not cause harmful interference.
2. This device must accept any interference received, including interference that may cause undesired operation.

**FCC Interference Statement (Part 15.105 (b))**

This equipment has been tested and found to comply with the limits for a Class B digital device, pursuant to Part 15 of the FCC Rules.

These limits are designed to provide reasonable protection against harmful interference in a residential installation. This equipment generates, uses, and can

radiate radio frequency energy and, if not installed and used in accordance with the instructions, may cause harmful interference to radio communications. However, there is no guarantee that interference will not occur in a particular installation. If this equipment does cause harmful interference to radio or television reception, which can be determined by turning the equipment off and on, the user is encouraged to try to correct the interference by one of the following measures:

1. Reorient or relocate the receiving antenna.
2. Increase the separation between the equipment and receiver.
3. Connect the equipment into an outlet on a circuit different from that to which the receiver is connected.
4. Consult the dealer or an experienced radio / TV technician for help.

**Industry Canada**

This device complies with Industry Canada License-exempt RSS standard(s).

Operation is subject to the following two conditions:

1. This device may not cause interference; and
2. This device must accept any interference, including interference that may cause undesired operation of the device.

This Class B digital apparatus complies with Canadian ICES-003.

**Industry Canada (Français)**

Cet appareil est conforme aux normes d'exemption de licence RSS d'Industry Canada.

Son fonctionnement est soumis aux deux conditions suivantes:

1. cet appareil ne doit pas causer d'interférence, et
2. cet appareil doit accepter toute interférence, notamment les interférences qui peuvent affecter son fonctionnement.

Cet appareil numérique de la classe B est conforme à la norme NMB-003 du Canada.

**Japanese approvals**

In the frequency band used for this device, campus radio stations (radios stations that require a license) and specified low power radio stations (radio stations that do not require license) for mobile identification and amateur radio stations (radio stations that require license) used in industries such as microwave ovens, scientific, medical equipment devices and production line of other factories are also being operated.

1. Before using this device, please make sure that campus radio stations and specified low power radio stations for mobile identification and amateur radio stations are not being operated nearby.
2. In case there is any case of harmful interference to campus radio stations for mobile identification caused by this device, please immediately change the frequency used or stop the transmission of radio waves and then consult about the measures to avoid interference (for example, the installation of partitions) through the contact information below.
3. Besides, when in trouble, such as when there is any case of harmful interference to specified low power radio stations for mobile identification or amateur radio stations caused by this device, please consult through the following contact information.

Contact information: Please contact your local authorized Raymarine dealer.

**Suppression ferrites**

Raymarine cables may be fitted with suppression ferrites. These are important for correct EMC performance. If a ferrite has to be removed for any purpose (e.g. installation or maintenance), it must be replaced in the original position before the product is used.

Use only ferrites of the correct type, supplied by Raymarine authorized dealers.

Where an installation requires multiple ferrites to be added to a cable, additional cable clips should be used to prevent stress on the connectors due to the extra weight of the cable.

## Declaration of conformity

Raymarine UK Ltd. declares that this product is compliant with the essential requirements of R&TTE directive 1999/5/EC.

The original Declaration of Conformity certificate may be viewed on the relevant product page at [www.raymarine.com](http://www.raymarine.com).

## Product disposal

Dispose of this product in accordance with the WEEE Directive.



The Waste Electrical and Electronic Equipment (WEEE) Directive requires the recycling of waste electrical and electronic equipment. Whilst the WEEE Directive does not apply to some Raymarine products, we support its policy and ask you to be aware of how to dispose of this product.

## Pixel defect policy

In common with all TFT units, the screen may exhibit a few wrongly-illuminated ("dead") pixels. These may appear as black pixels in a light area of the screen or as colored pixels in black areas.

If your display exhibits MORE than the number of wrongly-illuminated pixels allowed (refer to the product *technical specification* for details), please contact your local Raymarine service center for further advice.

## Warranty registration

To register your Raymarine product ownership, please visit [www.raymarine.com](http://www.raymarine.com) and register online.

It is important that you register your product to receive full warranty benefits. Your unit package includes a bar code label indicating the serial number of the unit. You will need this serial number when registering your product online. You should retain the label for future reference.

## IMO and SOLAS

The equipment described within this document is intended for use on leisure marine boats and workboats NOT covered by International Maritime Organization (IMO) and Safety of Life at Sea (SOLAS) Carriage Regulations.

## Technical accuracy

To the best of our knowledge, the information in this document was correct at the time it was produced. However, Raymarine cannot accept liability for any inaccuracies or omissions it may contain. In addition, our policy of continuous product improvement may change specifications without notice. As a result, Raymarine cannot accept liability for any differences between the product and this document. Please check the Raymarine website ([www.raymarine.com](http://www.raymarine.com)) to ensure you have the most up-to-date version(s) of the documentation for your product.

## a9x Display variants

a9x multifunction displays (MFDs) are available in the following variants:

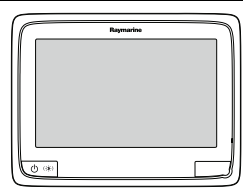
	
<b>Non-sonar variant</b>	a95 — (E70232)
<b>Sonar variant</b>	a97 — (E70233)
<b>DownVision variant</b>	a98 — (E70234)

<b>Features</b>	<ul style="list-style-type: none"> <li>• NMEA 0183</li> <li>• Bluetooth</li> <li>• Wi-Fi</li> <li>• Internal GNSS (GPS / GLONASS) receiver</li> <li>• GA150 external antenna connection</li> </ul>
<b>Controls</b>	 Multi-Touch touchscreen (HybridTouch when paired with a remote keypad.)

## a12x Display variants

a12x multifunction displays (MFDs) are available in the following variants:

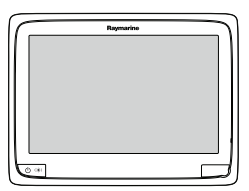
	
<b>Non-sonar variant</b>	a125 — (E70235)
<b>Sonar variant</b>	a127 — (E70236)
<b>DownVision variant</b>	a128 — (E70237)

<b>Features</b>	<ul style="list-style-type: none"> <li>• NMEA 0183</li> <li>• Bluetooth</li> <li>• Wi-Fi</li> <li>• Internal GNSS (GPS / GLONASS) receiver</li> <li>• GA150 external antenna connection</li> </ul>
<b>Controls</b>	 <p>Multi-Touch touchscreen (HybridTouch when paired with a remote keypad.)</p>

## Handbook illustrations

The illustration of the multifunction display (MFD) below is used throughout this manual and unless otherwise stated can apply to all variants of a Series MFDs.

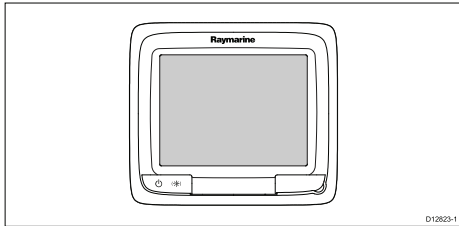

## Location and mounting

### Selecting a location

#### General location requirements

When selecting a location for the unit it is important to consider a number of factors.

#### Ventilation requirements

To provide adequate airflow:

- Ensure that equipment is mounted in a compartment of suitable size.
- Ensure that ventilation holes are not obstructed.
- Ensure adequate separation of equipment.

#### Mounting surface requirements

Ensure units are adequately supported on a secure surface. Do NOT mount units or cut holes in places which may damage the structure of the vessel.

#### Cable routing requirements

Ensure the unit is mounted in a location which allows proper routing and connection of cables:

- Minimum cable bend radius of 100 mm (3.94 in) is required unless otherwise stated.
- Use cable supports to prevent stress on connectors.

#### Electrical interference

Select a location that is far enough away from devices that may cause interference, such as motors, generators and radio transmitters/receivers.

#### GPS location requirements

In addition to general guidelines concerning the location of marine electronics, there are a number of environmental factors to consider when installing equipment with an internal GPS antenna.

#### Mounting location



##### • Above Decks mounting:

Provides optimal GPS performance. (For equipment with appropriate waterproof rating.)

##### • Below Decks mounting:

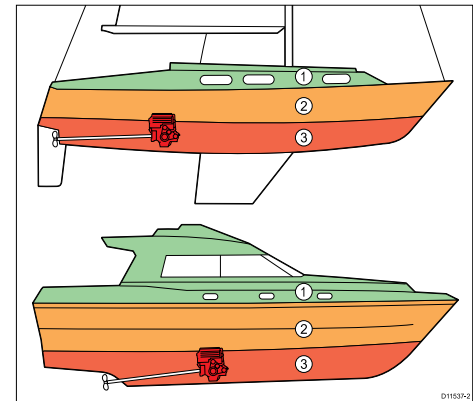
GPS performance may be less effective and may require an external GPS antenna mounted above decks.



1	.	 This location provides optimal GPS performance (above decks).
2	.	 In this location, GPS performance may be less effective.
3	.	 This location is NOT recommended for GPS antenna.

#### Vessel construction

The construction of your vessel can have an impact on GPS performance. For example, the proximity of heavy structure such as a structural bulkhead, or the interior of larger vessels may result in a reduced GPS signal. Before locating equipment with an internal GPS antenna below decks, seek professional assistance and consider use of an external GPS antenna mounted above decks.

#### Prevailing conditions

The weather and location of the vessel can affect the GPS performance. Typically calm clear conditions provide for a more accurate GPS fix. Vessels at extreme northerly or southerly latitudes may also receive a weaker GPS signal. GPS antenna mounted below decks will be more susceptible to performance issues related to the prevailing conditions.

## Viewing angle considerations

As display contrast, color and night mode performance are all affected by the viewing angle, Raymarine recommends you temporarily power up the display when planning the installation, to enable you to best judge which location gives the optimum viewing angle.

### Viewing angle

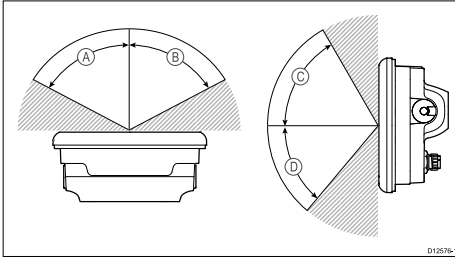

	a6x	a7x	a9x	a12x
A (Right)	60°	75°	80°	80°
B (Left)	60°	75°	80°	80°
C (Up)	60°	70°	80°	80°
D (Down)	50°	75°	80°	80°

**Note:** The viewing angles stated above were taken using internationally agreed standards and should be used for comparison purposes only. Do NOT install the product before testing its viewability in the desired location.

### Compass safe distance

To prevent potential interference with the vessel's magnetic compasses, ensure an adequate distance is maintained from the display.

When choosing a suitable location for the multifunction display you should aim to maintain the maximum possible distance between the display and any

compasses. Typically this distance should be at least 1 m (3 ft) in all directions. However for some smaller vessels it may not be possible to locate the display this far away from a compass. In this situation, the following figures provide the minimum safe distance that should be maintained between the display and any compasses.

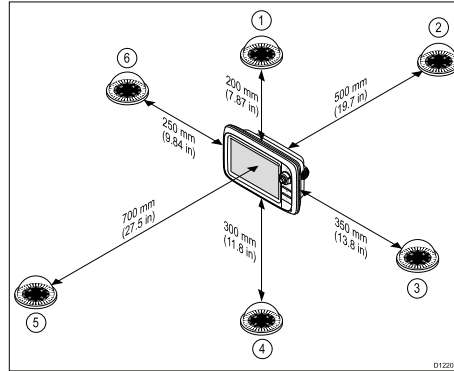

Item	Compass position in relation to display	Minimum safe distance from display
1	Top	200 mm (7.87 in.)
2	Rear	500 mm (19.7 in.)
3	Right-hand side	350 mm (13.8 in.)
4	Underside	300 mm (11.8 in.)
5	Front	700 mm (27.5 in.)
6	Left-hand side	250 mm (9.84 in.)

## a Series product dimensions

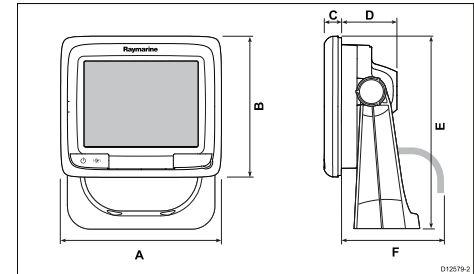

	a6x	a7x	a9x	a12x
A	163.6 mm (6.4 in.)	205.1 mm (8 in.)	250.1 mm (9.8 in.)	318 mm (12.5 in.)
B	143.5 mm (5.6 in.)	147.1 mm (5.8 in.)	189.5 mm (7.5 in.)	238.3 mm (9.4 in.)
C	17.5 mm (0.7 in.)	14.5 mm (0.57 in.)	14.5 mm (0.57 in.)	14.5 mm (0.57 in.)
D	56.6 mm (2.2 in.)	59.1 mm (2.3 in.)	68.1 mm (2.7 in.)	69.6 mm (2.7 in.)
E	162.4 mm (6.4 in.)	163.3 mm (6.4 in.)	198.26 mm (7.8 in.)	248.14 mm (9.8 in.)
F	150 mm (5.9 in.)	150 mm (5.9 in.)	150 mm (5.9 in.)	150 mm (5.9 in.)

### Mounting

the display can be surface mounted.

Before mounting the unit, ensure that you have:

- Selected a suitable location.
- Identified the cable connections and route that the cables will take.
- Detached the front bezel.



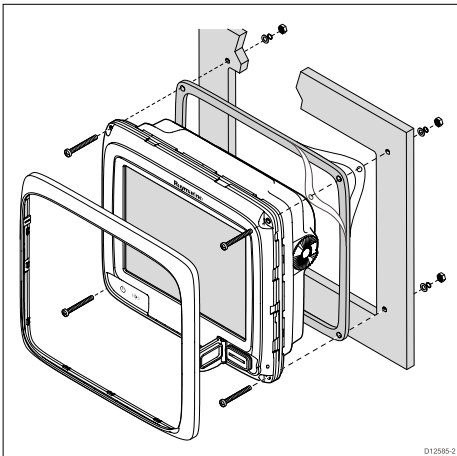

1. Check the selected location for the unit. A clear, flat area with suitable clearance behind the panel is required.
2. Drill or knock out the 4 mounting holes on the unit

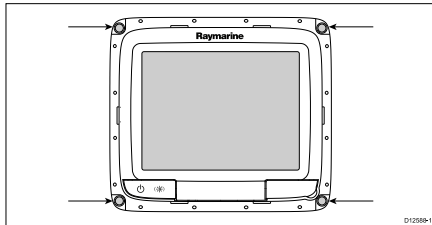

3. Fix the appropriate cutting template supplied with the product, to the selected location, using masking or self-adhesive tape.
4. Using a suitable hole saw (the size is indicated on the template), make a hole in each corner of the cut-out area.
5. Using a suitable saw, cut along the inside edge of the cut-out line.

6. Ensure that the unit fits into the removed area and then file around the rough edge until smooth.
7. Drill 4 holes as indicated on the template to accept the securing screws.
8. Place the gasket onto the display unit and press firmly onto the flange.
9. Connect the power, data and other cables to the unit.
10. Slide the unit into place and secure using the provided fixings.

**Note:** The supplied gasket provides a seal between the unit and a suitably flat and stiff mounting surface or binnacle. The gasket should be used in all installations. It may also be necessary to use a marine-grade sealant if the mounting surface or binnacle is not entirely flat and stiff or has a rough surface finish.

### Bracket (trunnion) mounting

The display can be mounted on a trunnion bracket.

Before mounting the unit ensure that you have:

- Selected a suitable location.
- Identified the cable connections and route that the cables will take.
- Attached the front bezel.

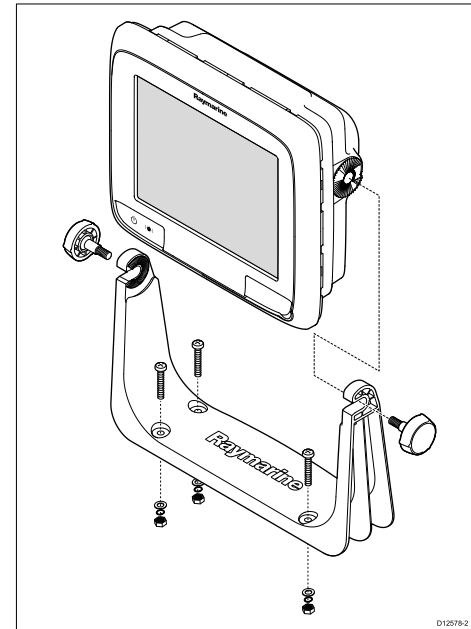

1. Mark the location of the mounting bracket screw holes on the chosen mounting surface.
2. Drill holes for the screws using a suitable drill, ensuring there is nothing behind the surface that may be damaged.
3. Use the fixings supplied with the mounting bracket to attach securely.
4. Attach the display to the mounting bracket.

### Front bezel

#### Attaching the front bezel

The following procedure assumes that the unit has already been mounted in position.

1. Carefully lift one edge of the screen protection film, so that it is accessible for removing when unit installation is complete.
2. Ensure the memory card slot door is in the open position.
3. Orientate the bottom-right side of the bezel under the lip of the chart card door and place the bezel over the front of the display, ensuring that the clips along the bottom edge of the bezel latch into position.

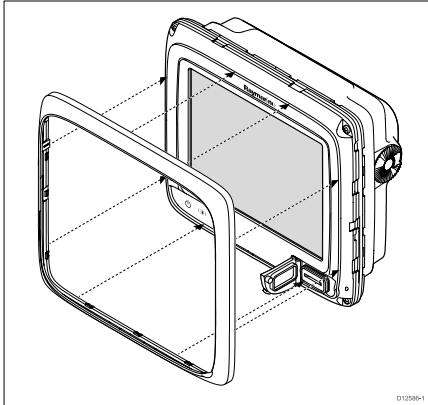

4. Ensure the bezel is correctly aligned with the display, as shown.
5. Apply firm but even pressure to the bezel along the:
  - i. Outer edges - work from the sides upwards and then along the top edge, to ensure that it clips securely into position.
  - ii. Inner edges - particularly along the chart card door edge, to ensure that the bezel sits flat.
6. Check that the **Power** button and chart card door are free to operate.

### Removing the front bezel

Before proceeding ensure the memory card slot door is open.

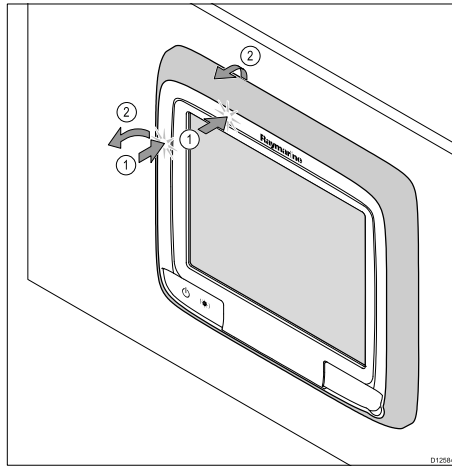

**Important:** Use care when removing the bezel. Do not use any tools to lever the bezel; doing so may cause damage.

1. Place both your thumbs on the upper left edge of the display, at the positions indicated in the diagram above.
2. Place your fingers underneath the bezel, at the positions indicated in the diagram above.
3. In a single firm motion, apply pressure to the outer edge of the display with your thumbs and pull the bezel towards you using your fingers.

The bezel should now come away from the display easily.

### a9x and a12x connections overview

The a9x and a12x variant MFDs include the following connections.

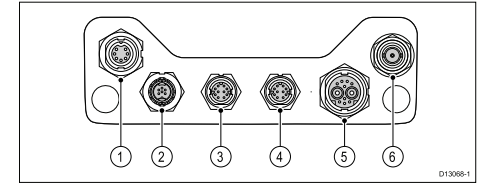

1. Sonar transducer (a97 and a127) / DownVision™ transducer (a98 and a128)
2. SeaTalk<sup>ng</sup>
3. Network 1 (RayNet)
4. Network 2 (RayNet)
5. Power and data
6. GA150 antenna

### Power and data connection

The details below apply to MFDs which have a combined power and data cable.

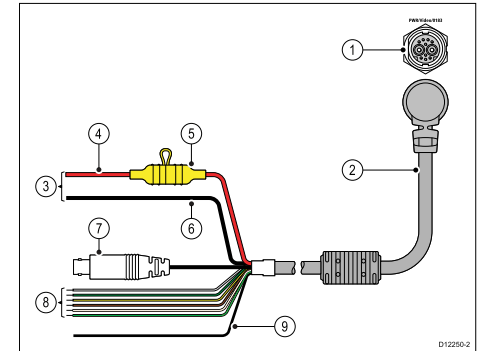

1. Power and data connection
2. Power and data cable

3. Connection to vessel's 12 V / 24 V dc power supply
4. Red cable (positive)
5. Fuse
6. Black cable (negative)
7. Video input cable
8. NMEA 0183 data cables
9. Shield (drain) wire (thin black wire; must be connected to RF ground point)

#### Power distribution

Raymarine recommends that all power connections are made via a distribution panel.

- All equipment must be powered from a breaker or switch, with appropriate circuit protection.
- All equipment should be wired to individual breakers if possible.



#### Warning: Product grounding

Before applying power to this product, ensure it has been correctly grounded, in accordance with the instructions in this guide.

#### Grounding — Dedicated drain wire

The power cable supplied with this product includes a dedicated shield (drain) wire for connection to a vessel's RF ground point.

It is important that an effective RF ground is connected to the system. A single ground point should be used for all equipment. The unit can be grounded by connecting the shield (drain) wire of the power cable to the vessel's RF ground point. On vessels without an RF ground system the shield (drain) wire should be connected directly to the negative battery terminal.

The dc power system should be either:

- Negative grounded, with the negative battery terminal connected to the vessel's ground.

- Floating, with neither battery terminal connected to the vessel's ground



#### Warning: Positive ground systems

Do not connect this unit to a system which has positive grounding.

#### Power cable

Depending on Multifunction display variant, the display is either supplied with a power cable or a combined power and data cable.

#### Power cables available

For flush mount installations a right angled power cable is available.

Cable	Part number	MFD variant
Straight power cable (supplied with a6x and a7x)	R70157	a6x and a7x
Right angled power cable	A80221	a6x and a7x
Straight power and data cable (supplied with a9x and a12x)	R62379	a9x and a12x
Right angled power and data cable	R70029	a9x and a12x

#### Cable extension

Power cables can be extended if required. The following restrictions apply to any extension to the power cable:

- Cable must be of a suitable gauge for the circuit load.
- Each unit should have its own dedicated power cable wired back to the distribution panel.

Total length (max)	Supply voltage	Cable gauge (AWG)
0–5 m (0–16.4 ft)	12 V	18
	24 V	20
5–10 m (16.4–32.8 ft)	12 V	14
	24 V	18
10–15 m (32.8–49.2 ft)	12 V	12
	24 V	16
15–20 m (49.2–65.5 ft)	12 V	12
	24 V	14

**Note:** a6x and a7x MFDs are 12 V only products. NEVER connect a 12 V only product to a 24 V system.

#### Breakers, fuses and circuit protection

The information below is provided as guidance to help protect your product. The example illustrations provided are for common vessel power arrangements, if you are unsure how to provide the correct level of protection then please consult a Raymarine authorized dealer for support.

#### Fuse and breaker rating

Fuse rating	Thermal breaker rating
7 A in-line fuse fitted within power cable.	5 A (if only connecting one device)

The suitable fuse rating for the thermal breaker is dependent on the number of devices you are connecting. If in doubt consult an authorized Raymarine dealer.

**Note:** Your product's power cable may have an in-line fuse already fitted, if not then you will need to add an in-line fuse to the positive wire of your products power connection.

### Distribution panel connection

It is recommended that your product is wired through your vessel's distribution panel via a thermal breaker or fuse.

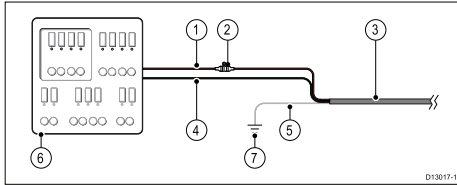

1. Vessel power supply positive (+)
2. In-line fuse. (If your products power cable does not have a built in fuse then an in-line fuse should be fitted.)
3. Product power cable
4. Vessel power supply negative (-)
5. \* Drain wire
6. Vessel distribution panel
7. \* Vessel RF ground point connection

**Note:** \* Only applicable to products that include a drain wire on the product's power cable.

### Battery connection with RF ground

If your vessel does not have a distribution panel then your product may be wired directly to the battery with the drain wire connected to the vessel's RF ground point.

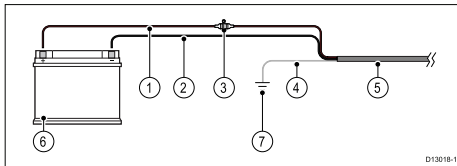

1. Vessel power supply positive (+)
2. Vessel power supply negative (-)
3. In-line fuse (If your products power cable does not have a built in fuse then an in-line fuse should be fitted.)
4. \* Drain wire
5. Product power cable
6. Vessel battery
7. \* Vessel RF ground point connection

**Note:** \* Only applicable to products that include a drain wire on the product's power cable.

### Battery connection with no RF ground

If your vessel does not have a distribution panel or an RF ground point then your product may be wired directly to the battery with the drain wire also connected to the battery's negative terminal.

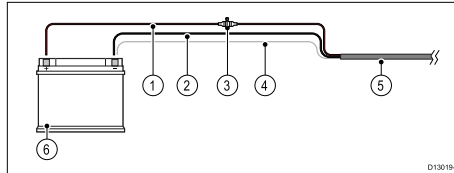

1. Vessel power supply positive (+)
2. Vessel power supply negative (-)
3. In-line fuse (If your products power cable does not have a built in fuse then an in-line fuse should be fitted.)
4. \* Drain wire connected to vessel negative power supply.
5. Product power cable
6. Vessel battery

**Note:** \* Only applicable to products that include a drain wire on the product's power cable.

### GA150 connection

a9x and a12x MFDs include an internal GNSS (GPS / GLONASS) receiver. The GA150 antenna can be used to improve the GNSS (GPS / GLONASS) receiver's reception.

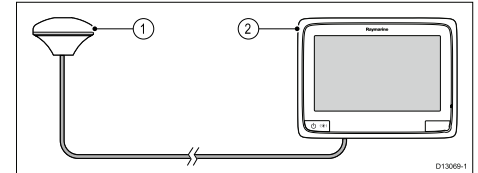

1. GA150 antenna
2. a9x or a12x variant MFD

For installation details for your external antenna, refer to the documentation that accompanied the antenna.

#### Note:

- The Beidou GNSS is supported but not currently available.
- A GA150 must be connected in order to receive the Beidou system when it becomes available.
- A software update will be required to add support for Beidou once the system is available. Please check with your Raymarine dealer for further details.

### Antenna cable length

The GA150 is supplied with a fitted 10 m (33 ft.) cable. The length of the antenna cable can be extended if required.

The antenna cable length can be extended by up to 10 m (33 ft.) giving a total maximum cable length of 20 m (66 ft.)

50 ohm coaxial cable and reliable connectors (offering protection against water ingress) must be used when extending the antenna cable.

**Note:** Extending the cable length by more than the recommended maximum length will result in signal degradation.

### Connecting an external antenna

Follow the steps below to connect the GA150 external antenna to your a9x or a12x variant MFD.

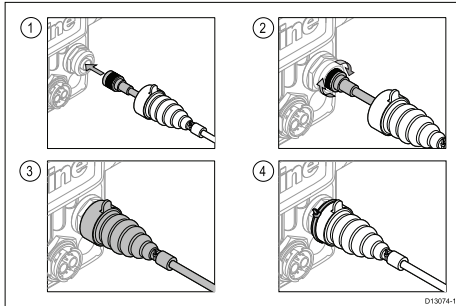

1. Fully insert the antenna's cable connector into the GA150 connector on the rear of your display.
2. Turn the locking collar clockwise until **TIGHT**.
3. Push the protective boot over the connection on the back of the display.
4. Use the supplied cable tie to secure the protective boot over the connection.

### NMEA 0183 connection

NMEA 0183 devices can be connected to compatible multifunction displays (MFDs) using the power and data cable.

**Note:** a6x and a7x variant MFDs do not support connection of NMEA 0183 devices using the power and data cable. To connect an NMEA 0183 device to an a6x or a7x MFD a SeaTalk<sup>®</sup> to NMEA 0183 adaptor is required.

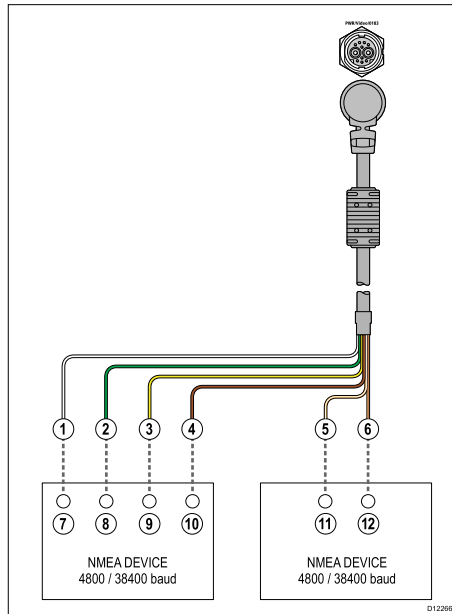

NMEA 0183 devices are connected using the power and data cable supplied with compatible MFDs.

2 NMEA 0183 ports are available:

- **Port 1:** Input and output, 4800 or 38400 baud rate.
- **Port 2:** Input only, 4800 or 38400 baud rate.

**Note:** The baud rate you want to use for each port input must be specified in the System Settings menu (**Homescreen** → **Set-up** → **System Settings** → **NMEA Set-up** → **NMEA Input Port**).

**Note:** For Port 1, both the input and output communicate at the same baud rate. For example, if you have one NMEA 0183 device connected to the display's Port 1 INPUT, and another NMEA 0183 device connected to the display's Port 1 OUTPUT, both NMEA devices must be using the same baud rate.

You can connect up to 4 NMEA 0183 devices to the display's NMEA 0183 OUTPUT (Port 1). You can connect a total of 2 NMEA 0183 devices to the display's NMEA 0183 INPUT ports.

Item	Device	Cable color	Port	Input / output	Positive (+) / negative (-)
1	Multi-function display	White	1	Input	Positive
2		Green	1	Input	Negative
3		Yellow	1	Output	Positive
4		Brown	1	Output	Negative
5		Orange / white	2	Input	Positive
6		Orange / green	2	Input	Negative
7	NMEA device	*	*	Output	Positive
8		*	*	Output	Negative
9		*	*	Input	Positive
10		*	*	Input	Negative
11	NMEA device	*	*	Output	Positive
12		*	*	Output	Negative

**Note:** \*Refer to instructions provided with the NMEA 0183 device.

## Memory cards and chart cards

MicroSD memory cards can be used to back up / archive data (e.g. Waypoint, and Tracks). Once data is backed up to a memory card old data can be deleted from the system, creating capacity for new data. The archived data can be retrieved at any time. Chart cards provide additional or upgraded cartography.

It is recommended that your data is backed up to a memory card on a regular basis. Do NOT save data to a memory card containing cartography.

### Compatible cards

The following types of MicroSD cards are compatible with your display:

- Micro Secure Digital Standard-Capacity (MicroSDSC)
- Micro Secure Digital High-Capacity (MicroSDHC)

### Note:

- The maximum supported memory card capacity is 32 GB.
- MicroSD cards must be formatted to use either the FAT or FAT 32 file system format to enable use with your MFD.

### Speed class rating

For best performance it is recommended that you use Class 10 or UHS (Ultra High Speed) class memory cards.

### Chart cards

Your product is pre-loaded with electronic charts (worldwide base map). If you wish to use different chart data, you can insert compatible chart cards into the unit's memory card reader.

### Use branded chart cards and memory cards

When archiving data or creating an electronic chart card, Raymarine recommends the use of quality branded memory cards. Some brands of memory card may not work in your unit. Please contact customer support for a list of recommended cards.

### Inserting a memory card or chart card

1. Open the card reader door.
2. Insert the card, as shown in the diagram below. For slot 1, the card contacts should be facing DOWN. For slot 2, the card contacts should be facing UP. Do NOT force the card. If the card does not fit easily into the slot, check the orientation.

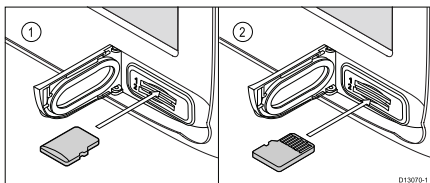

3. Gently press the card all the way in to the card slot, as shown in the diagram below. The card is secure when an audible click is heard.

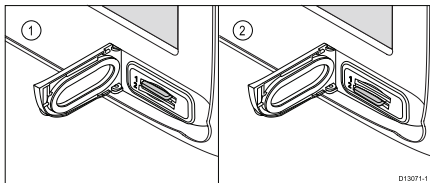

4. To prevent the ingress of water and consequent damage, close the card reader door.

### Removing a memory card or chart card

From the homescreen:

1. Select **My Data**.
2. Select **Eject Card**.

A message is displayed prompting you to select the memory device you want to eject.

3. Select **SD1** for a memory card in the top card slot, or **SD2** for a memory card in the bottom card slot.
4. Open the card reader door.
5. Push the edge of the card towards the unit, until an audible click is heard.

The card is released from the card slot mechanism, as shown in the following diagram:

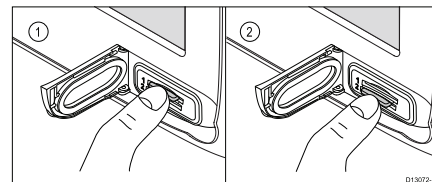

6. Use your fingers to pull the card clear of the card slot, using the edge of the card.

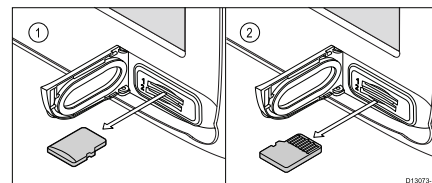

7. To prevent the ingress of water and consequent damage, close the chart card door.

**Note:** You can also power off the multifunction display and follow steps 4 to 7 above.



### Powering the display on

1. Press the **POWER** button.
2. Select **Accept** to acknowledge the disclaimer message.

## Powering the display off

1. Press and hold the **POWER** button until the countdown reaches zero.

**Note:** If the **POWER** button is released before the countdown reaches zero, the power off is cancelled.



## Adjusting the display brightness

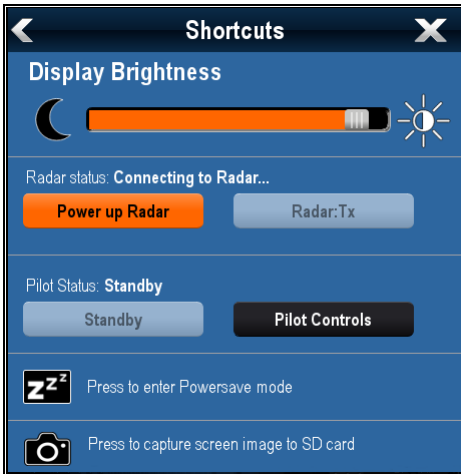

1. Press the **POWER** button once. The Shortcuts menu is displayed.
2. Adjust the brightness to the required level using the on-screen brightness slider bar control, or
3. Touch the Sun icon to increase the brightness level or the Moon icon to decrease the brightness level.

**Note:** The brightness level can also be increased by pressing the **Power** button multiple times.

## Simulator mode

The Simulator mode enables you to practice operating your display without data from a GPS antenna, radar scanner, AIS unit, or fishfinder.

The simulator mode is switched on / off in the **System Setup Menu**.

**Note:** Raymarine recommends that you do NOT use the simulator mode whilst navigating.

**Note:** The simulator will NOT display any real data, including any safety messages (such as those received from AIS units).

**Note:** Any system settings made whilst in Simulator mode are NOT transmitted to other equipment.

### Enabling and disabling simulator mode

You can enable and disable simulator mode by following the steps below.

With the homescreen displayed:

1. Select **Set-Up**.
2. Select **System Settings**.
3. Select **Simulator**.
4. Select On to turn simulator mode on, or
5. Select Off to turn simulator mode off.

**Note:** The Demo movie option is for retail demonstration purposes only.

## Homescreen overview — Touch only displays

The Homescreen provides a central point of access for your display's applications, data and settings.

- The Homescreen provides quick access to your data (waypoints, routes, tracks, images and videos) and backup settings.
- The Homescreen consists of a number of Homescreen pages. Swipe the screen left or right

with your finger to scroll through the available Homescreen pages.

- Each Homescreen page consists of a number of icons. Applications are started by selecting the relevant icon.



Screen item	Description
1	<b>Waypoint</b> — select the icon to access the waypoint list. Select and hold on the icon to place a Man Overboard (MOB) marker at your vessel's current position.
2	<b>My Data</b> — this icon enables you to centrally manage your data including route, track, and waypoint lists. You can also access saved pictures and videos and backup settings.
3	<b>Customize</b> — select this icon to configure application pages and display preferences.
4	<b>Set-up</b> — select this icon to access the system set-up menus.

Screen item	Description
5	<b>Icon</b> — each icon represents an application page. A page can display multiple applications simultaneously.
6	<b>Status bar</b> — the status icons confirm the status of externally-connected equipment, including GPS, AIS, radar, sonar and autopilot units.



## Pages

Pages are made up of 1 to 4 panes that are used to display applications on your multifunction display (MFD).

Pages are accessed using the icons on the Homescreen.

- You can create up to 2 application panes per page using an MFD that has a screen size of 7 inches or less.
- You can create up to 4 application panes per page using an MFD that has a screen size of greater than 7 inches.
- MFDs with a screen size of 7 inches or less can view pages with more than 2 application panes but only if they are sharing the Homescreen of an MFD which is capable of creating those pages.

Pages can be customized, enabling you to group your applications into different pages, each designed for a specific purpose. For example, you could have a page that includes the chart and fishfinder applications, suitable for fishing, and another page that includes the chart and data applications, which would be suitable for general sailing.

	Icon for a page featuring a single application.
	Icon for a page featuring multiple applications.

You can also define the layout for each page, which determines how the applications are arranged on the screen.

### Changing an existing page on the homescreen

With the homescreen displayed:

- Select **Customize**.
- Select **Homescreen**.
- Select **Edit Page**.
- Select the page icon that you want to change.  
The Customize menu options are displayed.
- Select the appropriate page layout (for example, "Splitscreen").
- Select the application(s) you want to display on the page, either by selecting the relevant menu item or dragging it over to the displayed page.
- Select **Finish**.  
The Rename Page dialog is displayed.
- Use the on-screen keyboard to name the page, then select **Save**.

## a Series Controls

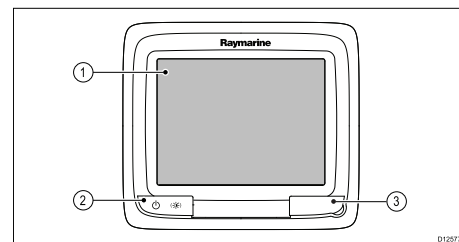

	Description	Functions
1	<b>Touchscreen</b>	Touch the screen to operate functions, including all menu operations.
2	<b>Power</b>	<ul style="list-style-type: none"> <li>Press once to switch the unit ON.</li> <li>Once powered on, press the Power button again to open the shortcuts page where you can adjust the brightness, perform a screen capture, access Powersave mode or access the power controls of external devices.</li> <li>Press and hold to switch the unit OFF.</li> <li>If an integrated pilot is engaged, press and hold to put the autopilot into STANDBY mode.</li> </ul>
3	<b>Card reader slot</b>	MicroSD card reader <ul style="list-style-type: none"> <li>a6x and a7x = 1 x MicroSD card slot</li> <li>a9x and a12x = 2 x MicroSD card slots</li> </ul>

## Touchscreen overview

The touchscreen provides an alternative to using physical buttons to control your multifunction display. All functions can be accessed using the touchscreen



**Note:** Raymarine strongly recommends that you familiarize yourself with touch operations while your vessel is anchored or moored. You may find it helpful to use the simulator mode (accessible from **Homescreen**→**Set-up**→**System Settings**) in these situations.

## Applications

	<p><b>Chart application</b> — provides a 2D or 3D graphical view of your charts to help you navigate. Waypoint, route, and track functions enable you to navigate to a specific location, build and navigate routes, or record where you've been. Chart cards provide higher levels of detail and 3D views.</p>
	<p><b>Fishfinder application</b> — with a transducer and a sonar variant multifunction display or compatible Sonar Module, you can use the fishfinder application to help you accurately distinguish between different sizes of fish, bottom structure, and underwater obstacles. You can also view sea depth and temperature data and mark points of interest such as fishing spots or wrecks.</p>
	<p><b>Radar application</b> — with a suitable radar scanner, you can use the radar application to track targets and measure distances and bearings. A number of automatic gain presets and color modes are provided to help you get the best performance from your radar scanner.</p>
	<p><b>Data application</b> — view system and instrument data on your multifunction display, for a range of compatible instruments. Use the joystick or touchscreen to scroll through the available data pages.</p>

	<p><b>Weather application</b> — (North America only). With a suitable weather receiver connected to your system, the weather application overlays historical, live, and forecasted weather graphics on a world map.</p>
	<p><b>Thermal cam application</b> — view and control a thermal camera using a compatible multifunction display.</p> <p><b>Note:</b> The thermal camera application is not available on a6x and a7x variant MFDs.</p>
	<p><b>Camera application</b> — view a video or camera source on your multifunction display.</p>
	<p><b>Doc Viewer</b> — view pdf documents stored on a MicroSD card.</p>
	<p><b>FUSION Link application</b> — link to and control a compatible Fusion entertainment system from your multifunction display.</p>
	<p><b>Sirius Audio application</b> — control Sirius radio from your multifunction display.</p>
	<p><b>User Manual</b> — Opens the English version of the product user manual stored on the display. To open translated user manuals stored on memory card use the Doc Viewer.</p>

## Alarms

Alarms alert you to a situation or hazard requiring your attention.

You can set up alarms to alert you to certain conditions, such as collision warnings and temperature limits.

Alarms are raised by system functions, and also external equipment connected to your multifunction display.

When an alarm sounds a message dialog is displayed on your multifunction display and any networked displays. The dialog states the reason for the alarm.

You can configure the behavior of certain alarms by selecting the Edit option on the message dialog or by using the **Alarms** menu, accessible from the homescreen via the **Set-Up** icon.





**Raymarine**<sup>®</sup>  
A FLIR COMPANY

[www.raymarine.com](http://www.raymarine.com)

CE 0168 