

NUMATICS®

E Series

Economic Tie-Rod Cylinder Line



www.numatics.com

E Series

Features and Benefits	3
How to Order	4
Basic E-Series Cylinders	5
Cushioned Cylinders	5
Basic E-Series Dimensions	5
E-Series Rod Ends	6
Piston Rod Ends	6
Standard and Optional Rod Ends	7
E-Series Double Rod Dimensions	7
Bottom Tapped Mount	8-9
Clevis and Eye Mounts	10
End Lug Mount	11
Trunnion Mounts	12
Accessories	13
How to Order - E Series Piston Rod Assembly	14
How to Order - E Series Repair Kit	15
How to Order - E Series Seal Kit	15
Piston Rod Assembly Kit Installation Instructions	16
Seal Installation Guide	16
Diagrams	17
Repair Kit Removal/Installation Instructions	18
Seal Kit Removal/Installation Instructions	19
World Switches	20-21
Specialty Cylinders	21
Sensing Part Numbers	22-24
Quick Disconnect Cables	25

The **E Series** is a cost-efficient cylinder line that is ideal for a variety of OEM applications, providing long-lasting and reliable service.

Tube

The file hard (60RC) high strength aluminum alloy **tube** provides a smooth corrosion free sealing surface and excellent abrasion resistance.

End Caps

The **end caps** are accurately machined from (6061-T6) solid aluminum bar stock. They are anodized for corrosion resistance. Additionally, a recess on the piston-mating surface (at both ends) enables the air to work on a larger piston area for effortless breakaway.

Rod Bushing

The cast iron **rod bushing** provides maximum load bearing support. This graphite filled material offers the best bearing surface with hard chrome plated piston rod.

Rod seal and wiper

The **rod seal and wiper** are made from a highly durable material for long-lasting service.

Piston rod

High strength steel **piston rod** has a ground, polished and hard chrome plated surface providing maximum life of bushing and seals.

Bushing retainer

The **bushing retainer** allows cartridge removal without disassembly.

Tie Rods

Tie rods are 100,000 psi minimum yield steel for maximum holding power. Tie rod threads are rolled for strength and engagement.

Piston seals

The **piston seals** are a Buna-N lip seals that provides smoother breakaway.

Wear band

The extra wide **wear band** is provided to support maximum loading.

Piston

The solid aluminum alloy **piston** is strong and lightweight.

Tube seals

The **tube seals** are compression type and reusable.

The floating cushion seal design gives the fastest stroke reversal possible by providing instantaneous full flow to piston. Each cushion has a flush, retained adjustment needle.



E Series Cylinder - How to Order

P2 E L - 04 A 1 C - C AA 0 B

Mount

- F1 = Front Flange
- F2 = Rear Flange
- P2 = Detachable Clevis
- P4 = Detachable Eye
- P7 = P2 and S4 Mount Combination
- S4 = Bottom Tapped
- S7 = End Lug
- T1 = Head Trunnion
- T2 = Cap Trunnion
- T4* = Mid Trunnion Fixed
- X0 = No Mount

*Specify "Xl" length.

Cylinder Type

E = Type "E" Cylinder

Bore

F = 1-1/4"	Q = 3-1/2"
I = 1-3/4"	S = 4-1/2"
L = 2"	T = 5"
M = 2-1/2"	U = 6"
N = 3"	W = 8"

Full Inches of Stroke

- 00 = 0" Stroke
- 01 = 1" Stroke
- 02 = 2" Stroke
- 03 = 3" Stroke
- 99 = 99" Stroke

Fractional Inches of Stroke

A = 0"	I = 1/2"
B = 1/16"	J = 9/16"
C = 1/8"	K = 5/8"
D = 3/16"	L = 11/16"
E = 1/4"	M = 3/4"
F = 5/16"	N = 13/16"
G = 3/8"	O = 7/8"
H = 7/16"	P = 15/16"

Port Modifications (Only on 1-1/4" Bore)

B = Port Modified
Note: Leave Blank if No Port Modifications

Magnet

- 0 = No Magnet
- 2 = Reed Magnet

Options

- AA = No Options
- BA** = Bumpers, Both Ends
- BC** = Bumpered Cap End
- BH** = Bumpered Head End
- KA = Stroke Adjuster
- DA = Double Rod End
- MA = Metallic Rod Scraper
- NA = Nickel Plated Cylinder
- SA = Stainless Steel Rods
- ST = Stainless Steel Rods and Tie Rods
- VA = FKM Seals
- 1A* = Rod Extension
- 2A* = Thread Extension
- 3A = Studded Rod End
- 4A* = Stop Tube

*Must specify length.
**Bumpers add .062" to OAL (per bumper)

Cushions

Position	1	2	3	4
No Cushion	A	A	A	A
Head and Cap	B	C	D	E
Head Only	F	G	H	J
Cap Only	K	L	M	N

Ports

Position	1/8"	1/4"	3/8"	1/2"	3/4"
1	B	C	D	E	F
2	H	I	J	K	L
3	N	O	P	Q	R
4	T	U	V	W	X

Rod End Codes

- 1 = Style #1 Standard Rod Diameter
- 2 = Style #2 Standard Rod Diameter
- 3 = Style #3 Standard Rod Diameter
- 4 = Special Threads, Standard Rod Diameter (must specify threads)

Example order:

Part Number: P2EL-04A1C-CAA0

Piston Rod Ends

Bore	Rod Dia.	Style #1 (Male Thread)	Style #2 (Male Thread)	Style #3 (Female Thread)
1-1/4	0.375	3/8-16	1/4-20	1/4-20
1-3/4, 2, 2-1/2, 3	0.750	3/4-10	1/2-13	1/2-13
3-1/2, 4-1/2, 5	1.000	1-8	3/4-10	3/4-10
6, 8	1.500	1 1/4-12	1-8	1 1/4-12

Dimensions: Inches

Basic E-Series Cylinders

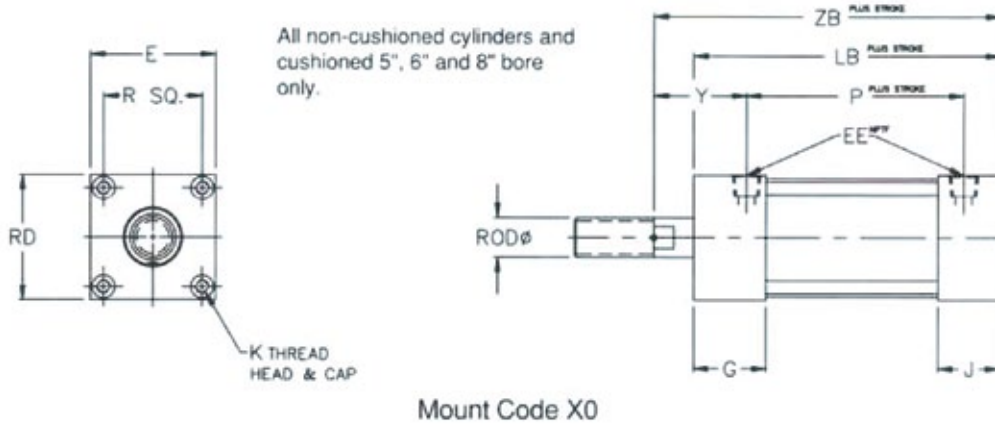

Cushioned Cylinders

1-1/4" through 4-1/2" bore only: Add 1" for each cushion
 5", 6" and 8" bore only: No change in length for cushions

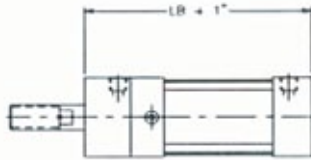

Head Cushion Only
Up to 4-1/2" Bore

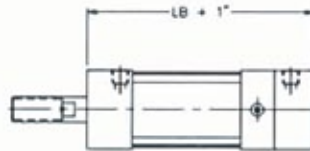

Cap Cushion Only
Up to 4-1/2" Bore

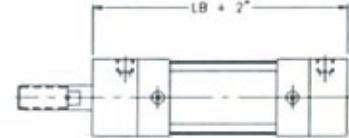

Head and Cap Cushioned
Up to 4-1/2" Bore

Basic E-Series Dimensions

Bore	Rod Dia.	E	EE	G	J	K	LB	P	R	RD	Y	ZB
1-1/4	0.375	1.813	1/8	1.125	0.750	1/4-28 X 0.38	2.906	2.063	1.281	1.813	1.125	3.531
1-3/4	0.750	2.375	1/4	1.437	1.235	5/16-24 X 0.50	3.797	2.362	1.718	2.375	1.500	4.547
2	0.750	2.375	1/4	1.437	1.235	1/4-28 X 0.38	3.797	2.362	1.875	2.375	1.500	4.547
2-1/2	0.750	2.875	3/8	1.437	1.235	5/16-24 X 0.50	3.797	2.425	2.203	2.875	1.438	4.547
3	0.750	3.375	3/8	1.437	1.235	5/16-24 X 0.50	3.797	2.425	2.625	3.375	1.438	4.547
3-1/2	1.000	4.000	1/2	2.000	1.250	3/8-24 X 0.63	4.545	3.076	3.219	4.125	1.844	5.545
4-1/2	1.000	5.000	1/2	2.000	1.250	1/2-20 X 0.63	4.545	3.076	4.031	5.125	1.844	5.545
5	1.000	5.500	1/2	2.000	1.250	1/2-20 X 0.63	4.797	3.328	4.100	5.500	1.844	5.797
6	1.500	6.500	3/4	2.000	1.500	1/2-20 X 0.63	5.3750	3.750	4.875	6.500	2.125	6.625
8	1.500	8.500	3/4	2.000	1.500	5/8-18 X 0.75	5.750	3.750	6.440	8.500	2.125	6.625

Dimensions: Inches

E-Series Rod Ends

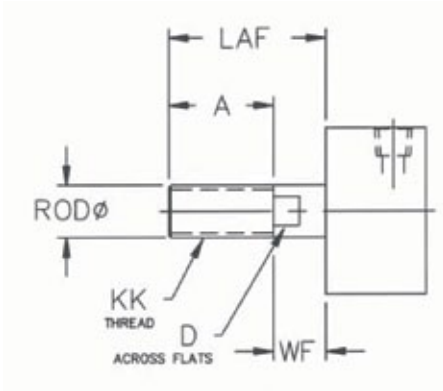

Style 1
1-1/4" Through 5" Bore Only

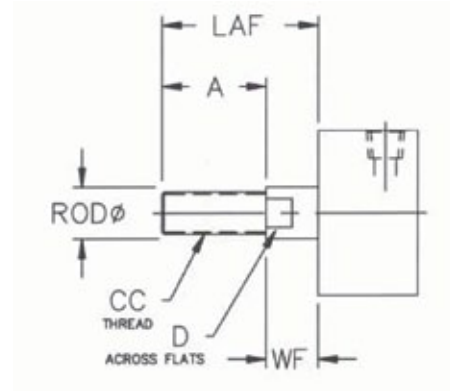

Style 2

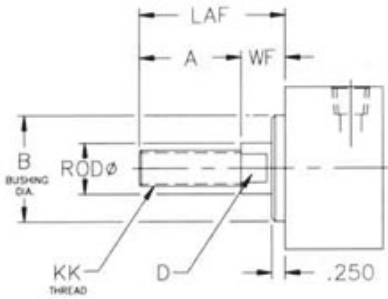

Style 1
6" and 8" Bore Only

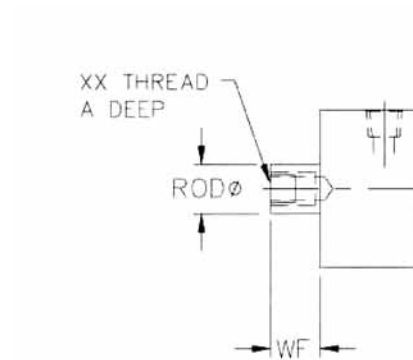

Style 3

Piston Rod Ends

Bore	Rod Dia.	Style #1 (Male Thread)	Style #2 (Male Thread)	Style #3 (Female Thread)	A	B	D	LAF	WF
		KK	CC	XX					
1-1/4	0.375	3/8-16	1/4-20	1/4-20	1.000	N/A	0.312	1.625	0.625
1-3/4, 2, 2-1/2, 3	0.750	3/4-10	1/2-13	1/2-13	1.500	N/A	0.625	2.250	0.750
3-1/2, 4-1/2, 5	1.000	1-8	3/4-10	3/4-10	1.625	N/A	0.875	2.625	1.000
6, 8	1.500	1 1/4-12	1-8	1 1/4-12	1.625	2.00	1.313	2.500	0.875

Dimensions: Inches

Standard and Optional Rod Ends

Double Rod

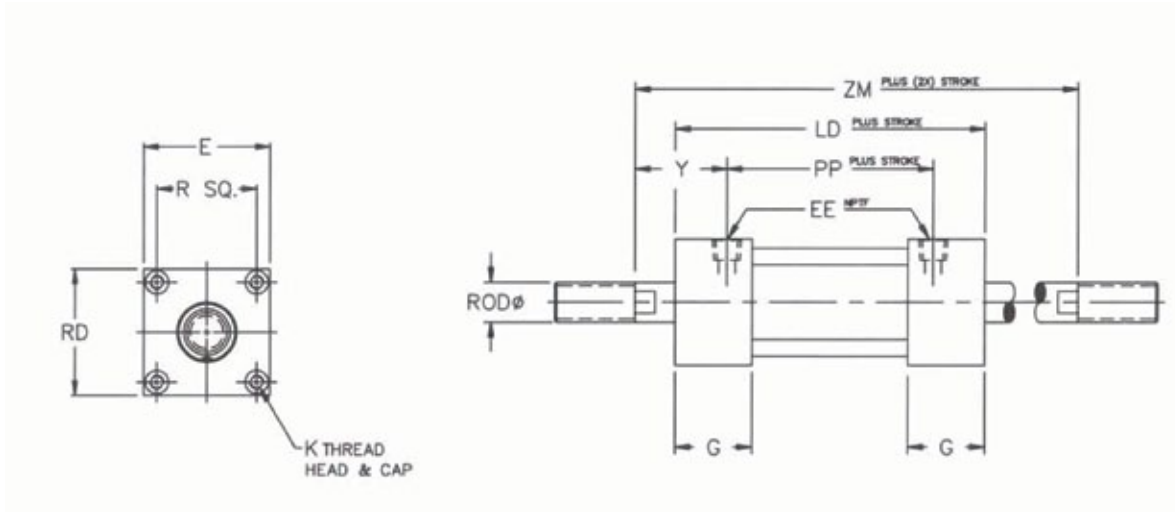

Order as "DA" Option

E-Series Double Rod Dimensions

Bore	Rod Dia.	E	EE	G	K	LD	PP	RD	Y	ZM
1-1/4	0.375	1.813	1/8	1.125	1/4-28 X 0.38	3.281	2.281	1.813	1.125	4.531
1-3/4	0.750	2.375	1/4	1.437	5/16-24 X 0.50	4.000	2.500	2.375	1.500	5.600
2	0.750	2.375	1/4	1.437	1/4-28 X 0.38	4.000	2.500	2.375	1.500	5.500
2-1/2	0.750	2.875	3/8	1.437	5/16-24 X 0.50	4.000	2.625	2.875	1.438	5.500
3	0.750	3.375	3/8	1.437	5/16-24 X 0.50	4.000	2.625	3.375	1.438	5.500
3-1/2	1.000	4.000	1/2	2.000	3/8-24 X 0.63	5.295	3.607	4.125	1.844	7.295
4-1/2	1.000	5.000	1/2	2.000	1/2-20 X 0.63	5.295	3.607	5.125	1.844	7.296
5	1.000	5.500	1/2	2.000	1/2-20 X 0.63	5.547	3.859	5.500	1.844	7.547
6	1.500	6.500	3/4	2.000	1/2-20 X 0.63	6.250	3.750	6.500	2.125	8.000
8	1.500	8.500	3/4	2.000	5/8-18 X 0.75	6.250	3.750	8.500	2.125	8.000

Dimensions: Inches

Bottom Tapped Mount

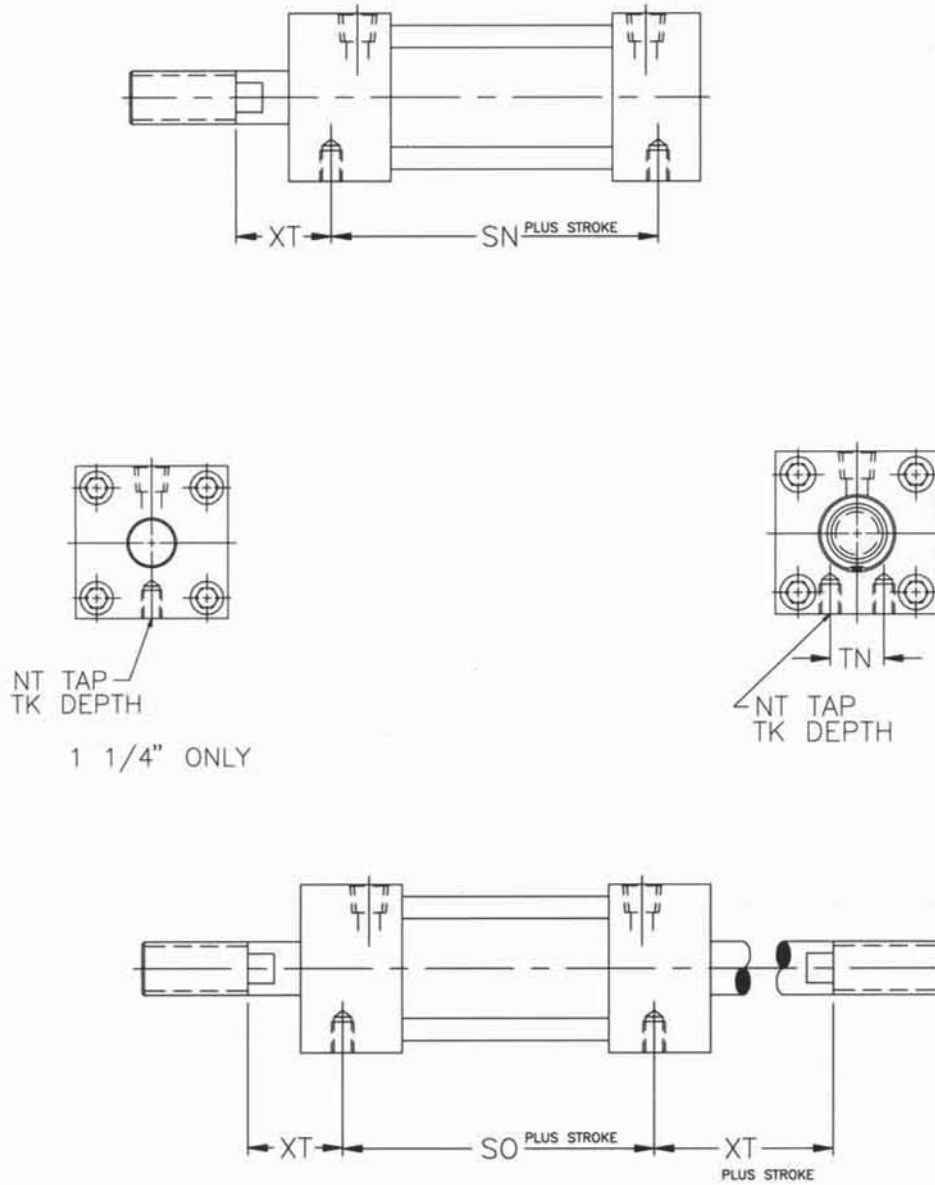

Bore	NT	TK	SN	SO	TN	XT
1-1/4	1/4-28	0.313	2.03	2.41	N/A	1.06
1-3/4	5/16-24	0.438	2.61	2.81	0.78	1.34
2	5/16-24	0.438	2.61	2.81	0.78	1.34
2-1/2	5/16-24	0.563	2.61	2.81	1.25	1.34
3	5/16-24	0.563	2.61	2.81	1.25	1.34
3-1/2	3/4-24	0.688	3.11	3.73	1.84	1.72
4-1/2	1/2-20	0.688	3.11	3.73	2.50	1.72
5	1/2-20	0.688	3.30	4.05	2.69	1.75
6	1/2-20	0.625	3.75	3.75	3.25	2.12
8	5/8-18	0.750	3.75	3.75	4.50	2.12

Dimensions: Inches

Flange Mounts

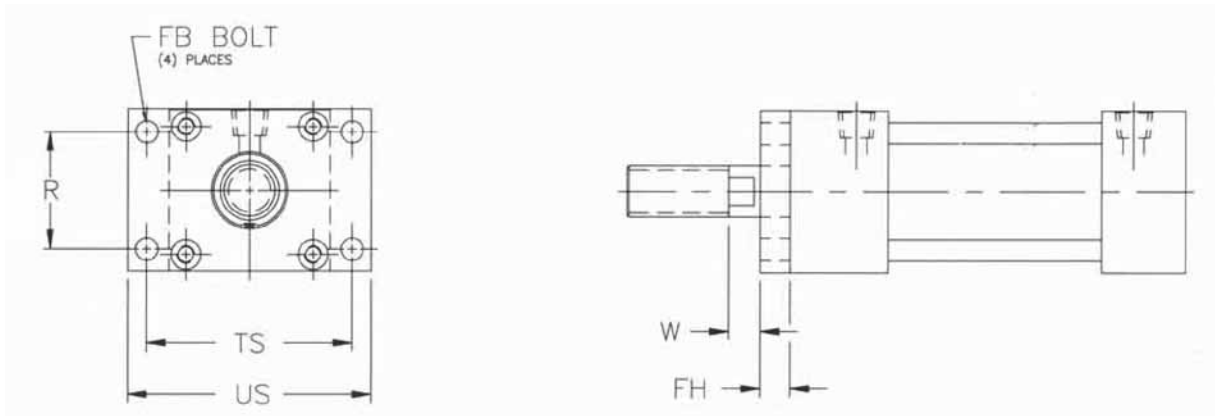

Mount Code F1

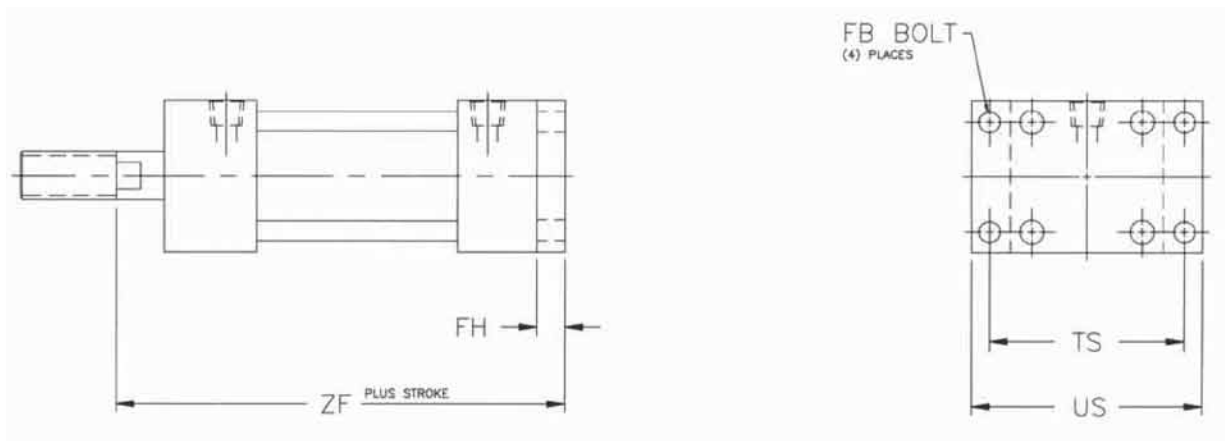

Mount Code F2

Bore	FB	FH	R	TS	US	W	ZF
1-1/4	0.250	0.375	1.281	2.312	2.750	0.250	3.906
1-3/4	0.313	0.438	1.718	3.031	3.594	0.313	4.984
2	0.313	0.438	1.875	3.031	3.625	0.313	4.984
2-1/2	0.313	0.438	2.203	3.437	4.000	0.313	4.984
3	0.313	0.438	2.625	3.875	4.500	0.313	4.984
3-1/2	0.375	0.625	3.219	5.062	5.937	0.375	6.170
4-1/2	0.500	0.625	4.031	6.062	7.000	0.375	6.170
5	0.500	0.625	4.100	6.562	7.500	0.375	6.422
6	0.500	0.750	4.875	7.625	8.500	0.125	7.375
8	0.625	0.875	6.440	10.000	11.250	0	7.500

Dimensions: Inches

Clevis and Eye Mounts

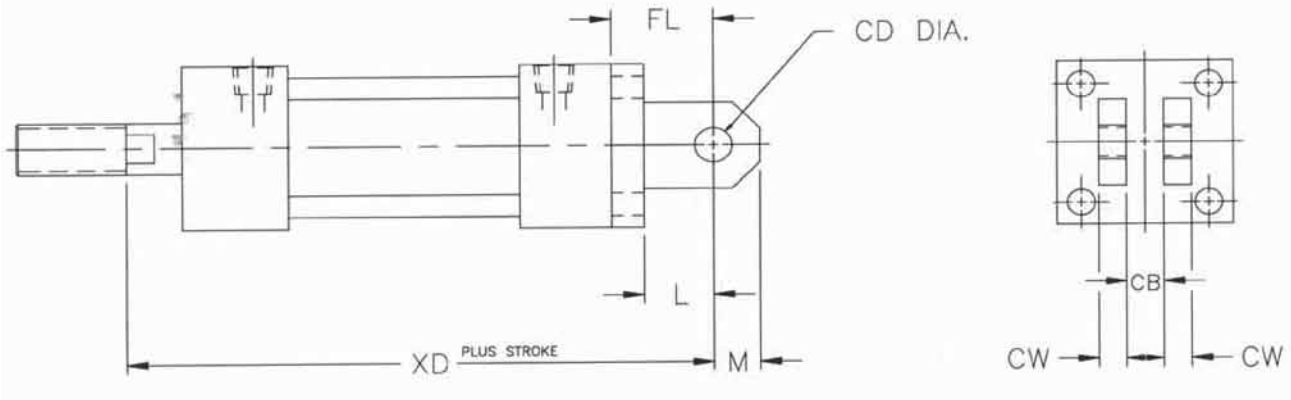

Mount Code P2

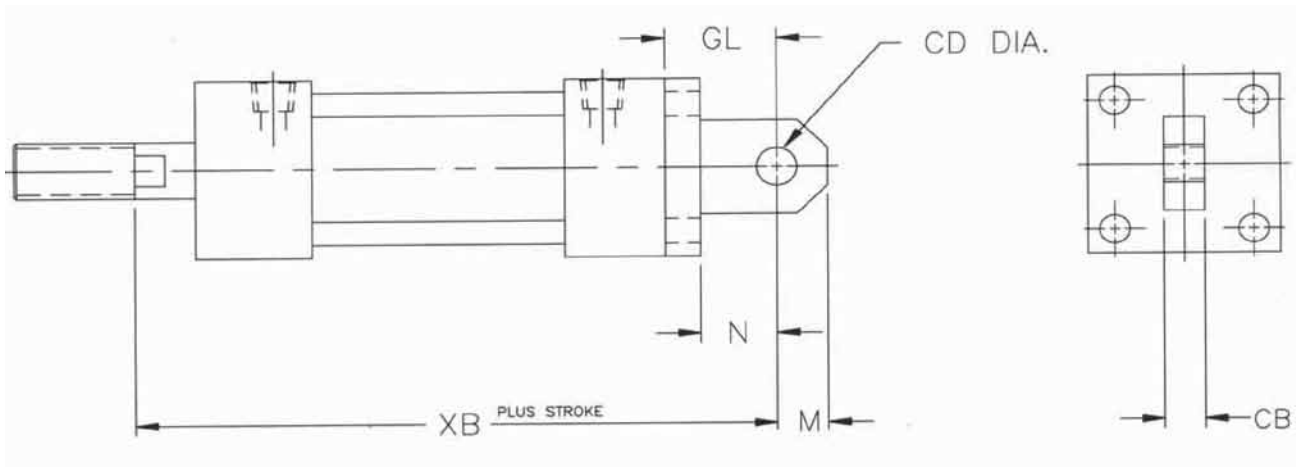

Mount Code P4

Bore	L	M	N	CB	CD	CW	FL	GL	XB	XD
1-1/4	0.750	0.438	1.250	0.250	0.375	0.250	1.000	1.500	5.031	4.531
1-3/4	1.000	0.625	1.500	0.500	0.500	0.375	1.375	1.875	6.422	5.922
2	1.000	0.625	1.500	0.500	0.500	0.375	1.375	1.875	6.422	4.922
2-1/2	1.125	0.813	1.750	0.500	0.625	0.375	1.500	2.125	6.675	6.047
3	1.750	0.816	1.750	0.500	0.625	0.375	2.125	2.125	6.675	6.672
3-1/2	1.563	1.000	2.500	0.500	0.750	0.500	2.063	3.000	8.545	7.608
4-1/2	1.875	1.125	3.000	0.500	0.750	0.500	2.375	2.500	9.297	8.172
5	1.875	1.125	3.000	0.500	0.750	0.500	2.375	3.500	9.297	8.172
6	1.625	1.125	1.625	1.500	1.000	0.750	2.250	2.250	8.875	8.875
8	1.625	1.125	1.625	1.500	1.000	0.750	.250	2.250	8.875	8.875

Dimensions: Inches

End Lug Mount

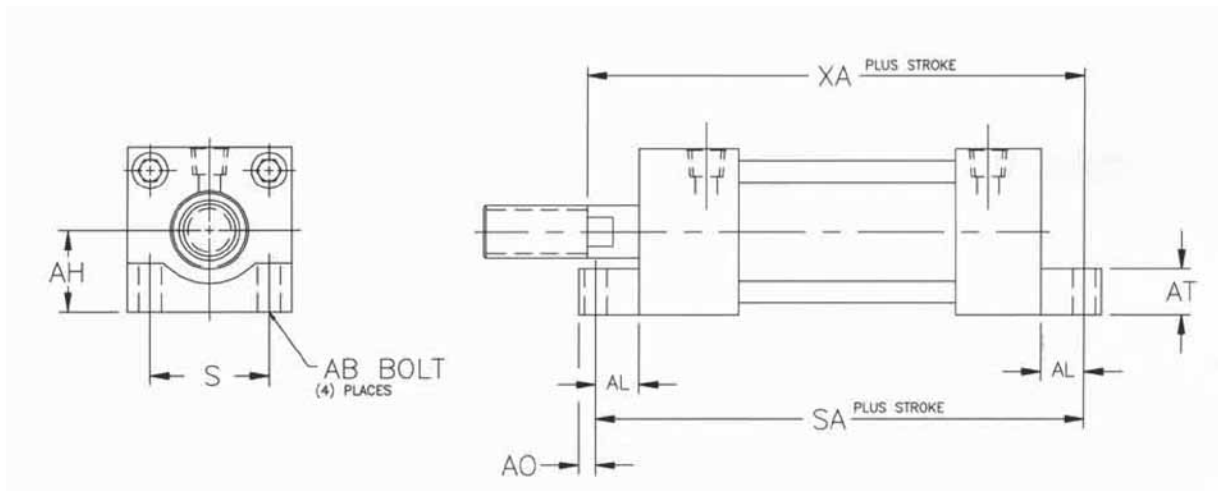

Mount Code S7

Bore	AB	AH	AL	AO	AT	S	SA	XA
1-1/4	1/4	0.906	0.500	0.250	0.625	1.281	3.906	4.031
1-3/4	5/16	1.188	0.625	0.250	0.875	1.781	5.047	5.173
2	1/4	1.188	0.500	0.250	0.625	1.875	4.797	5.048
2-1/2	5/16	1.438	0.625	0.250	0.875	2.203	5.047	5.173
3	5/16	1.688	0.625	0.250	0.875	2.625	5.047	5.173
3-1/2	1/2	2.063	1.000	0.375	1.375	3.219	6.545	6.546
4-1/2	1/2	2.563	1.000	0.375	1.375	4.031	6.545	6.545
5	1/2	2.750	1.000	0.375	1.375	4.100	6.797	6.797
6	1/2	3.250	1.000	0.375	1.375	4.875	7.750	7.625
8	1/2	4.250	1.250	0.750	2.000	6.440	8.250	7.875

Dimensions: Inches

Trunnion Mounts

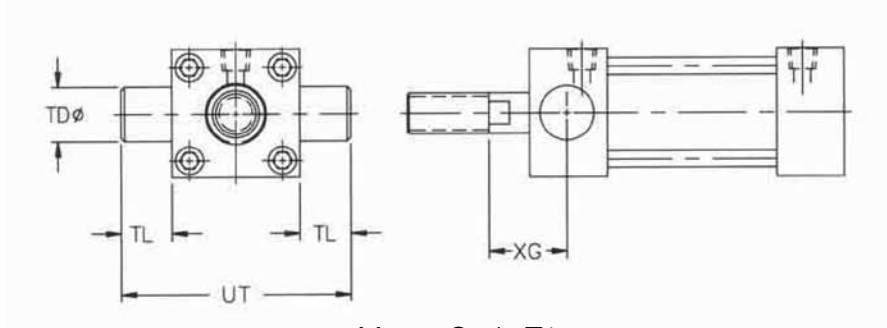

Mount Code T1

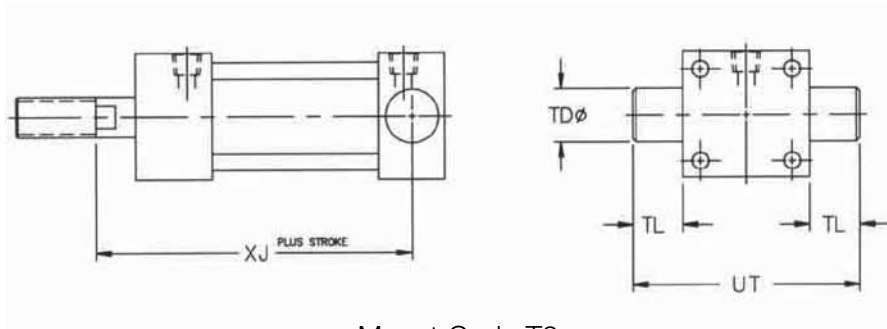

Mount Code T2

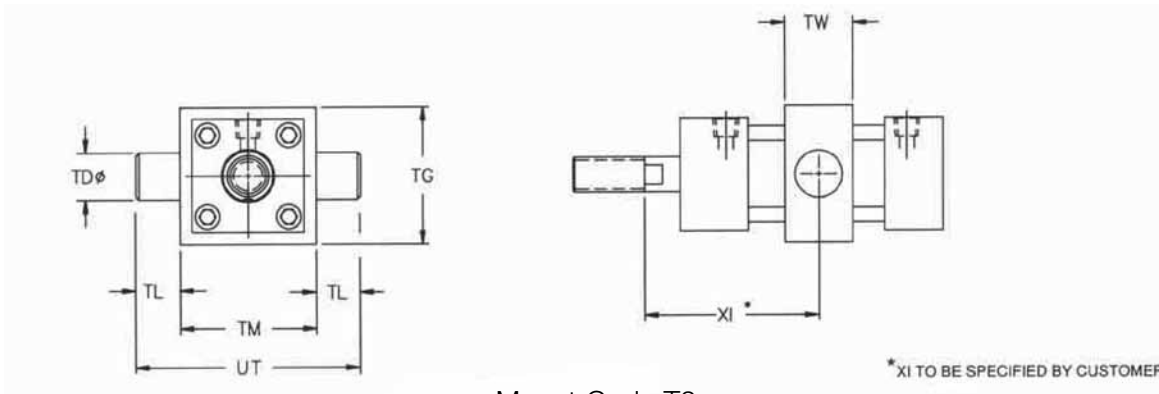

Mount Code T2

Bore	TD	TG	TL	TM	TW	UT	XG	XJ
1-1/4	0.375	2.375	0.438	2.375	1.250	2.688	1.156	3.188
1-3/4	1.000	2.875	0.938	2.875	1.438	4.250	1.438	3.959
2	1.000	2.875	0.938	2.875	1.438	4.250	1.438	3.959
2-1/2	1.000	3.375	0.938	3.375	1.438	4.750	1.438	3.959
3	1.000	4.125	0.938	4.000	1.438	5.250	1.438	3.959
3-1/2	1.000	5.125	0.938	5.000	2.000	5.875	1.953	4.967
4-1/2	1.000	5.500	0.938	5.500	2.000	6.875	1.953	4.967
5	1.000	6.500	0.938	6.500	2.000	7.375	1.953	5.219
6	1.375	8.500	1.375	8.500	2.000	9.250	1.830	5.922
8	1.375	N/A	1.375	N/A	N/A	11.250	1.830	5.922

Dimensions: Inches

Accessories

Detachable Eye

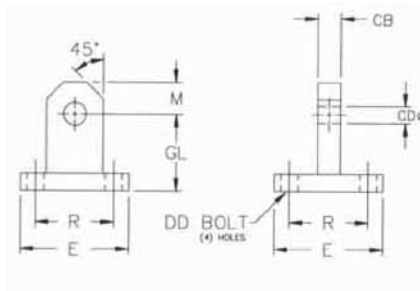

Pivot Pin for Detachable Clevis

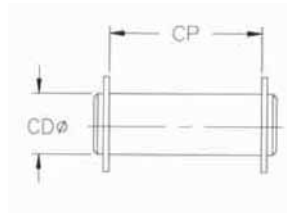

Detachable Clevis

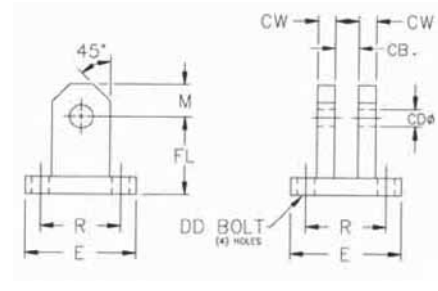

Bore	Clevis	PIN	Eye	CB	CD	CP	CW	DD	E	FL	GL	M	R
1-1/4	E500-001	E500-401	E500-101	0.250	0.375	0.750	0.250	1/4	1.813	1.000	1.500	0.438	1.281
1-3/4	E500-002	E500-402	E500-102	0.500	0.500	1.250	0.375	5/16	2.375	1.375	1.875	0.625	1.718
2	E500-003	E500-402	E500-103	0.500	0.500	1.250	0.375	5/16	2.375	1.375	1.875	0.625	1.875
2-1/2	E500-304	E500-403	E500-104	0.500	0.625	1.250	0.375	5/16	2.875	1.500	2.125	0.813	2.203
3	E500-305	E500-403	E500-105	0.500	0.625	1.250	0.375	5/16	3.375	2.125	2.125	0.813	4.625
3-1/2	E500-006	E500-404	E500-106	0.500	0.750	1.500	0.500	3/8	4.000	2.063	3.000	1.000	3.219
4-1/2	E500-007	E500-404	E500-107	0.500	0.750	1.500	0.500	1/2	5.000	2.375	3.500	1.125	4.031
5	E500-008	E500-404	E500-108	0.500	0.750	1.500	0.500	1/2	5.500	2.375	3.500	1.125	4.100
6	E500-009	E500-405	E500-109	1.500	1.000	3.000	0.750	1/2	6.500	2.250	2.250	1.125	4.875
8	E500-010	E500-405	E500-110	1.500	1.000	3.000	0.750	5/8	8.500	2.250	2.250	1.125	6.440

Rod Clevis

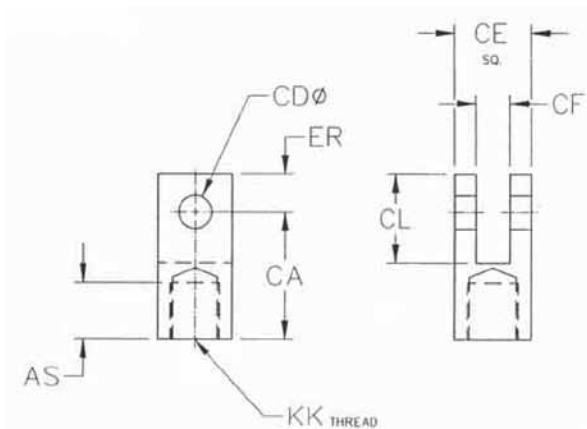

Pivot Pin for Rod Clevis

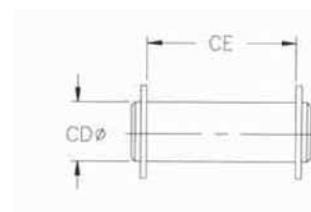

Bore	Clevis	PIN	AS	CA	CD	CE	CF	CL	ER	KK
1-1/4	E500-301	E500-401	0.875	1.344	0.375	0.750	0.250	0.906	0.375	3/8-16
1-3/4, 2	E500-302	E500-406	1.000	1.875	0.500	1.125	0.500	1.313	0.563	3/4-10
2-1/2, 3	E500-303	E500-407	1.000	2.063	0.625	1.125	0.500	1.500	0.563	3/4-10
2-1/2	E500-304	E500-404	1.000	2.313	0.750	1.500	0.500	1.875	0.750	1-8
3	E500-305	E500-408	1.625	3.000	1.000	2.000	1.000	2.000	1.000	1 1/4-12

How to Order - E Series Piston Rod Assembly

E92 - F 1 N 0 - 01 A - AA

Type

E92 = E Series Piston Rod Assembly

Bore

- F = 1-1/4"
- I = 1 3/4"
- L = 2"
- M = 2-1/2"
- N = 3"
- Q = 3-1/2"
- S = 4-1/2"
- T = 5"
- U = 6"
- W = 8"

Rod Code

- 1 = Style #1 Standard Rod Diameter
- 2 = Style #2 Standard Rod Diameter
- 3 = Style #3 Standard Rod Diameter
- 4= Special Threads, Standard Rod Diameter (must specify threads)

Cushion

- N = No Cushion
- B = Both Ends Cushioned
- H = Head End Cushioned
- C = Cap End Cushioned

Magnet

- 0 = No Magnet
- 2 = Reed Magnet

Note: Options listed are ones that apply to a piston rod assembly only. Model number is set up to use option code supplied with original cylinder or with any above.

Option

- AA = No Option
- BC = Bumpered Cap End
- BH = Bumpered Head End
- DA = Double Rod
- JN = Jam Nut
- KA = Stroke Adjust
- NA = Nickel Plated
- SA = Stainless Rod
- VA = FKM Seals
- 1A* = Rod Extension
- 1B* = Rear Rod Extension
- 2A* = Thread Extension
- 2B* = Rear Thread Extension
- 3A = Rod Stud
- 3B = Rear Rod Stud
- 4A* = Stop Tube
- * Must specify length

Fractional Inches of Stroke

- A = 0" I = 1/2"
- B = 1/16" J = 9/16"
- C = 1/8" K = 5/8"
- D = 3/16" L = 11/16"
- E = 1/4" M = 3/4"
- F = 5/16" N = 13/16"
- G = 3/8" O = 7/8"
- H = 7/16" P = 15/16"

Full Inch of Stroke

- 00 = 0" Stroke
- 01 = 1" Stroke
- 02 = 2" Stroke
- 03 = 3" Stroke
- 04 = 4" Stroke
- 99 = 99" Stroke

Rod End Styles, Diameters and Threads

Bore	Rod Dia.	Style #1 (Male Thread)	Style #2 (Male Thread)	Style #3 (Female Thread)
1-1/4"	0.375	3/8-16	1/4-20	1/4-20
1-3/4", 2", 2-1/2", 3"	0.750	3/4-10	1/2-13	1/2-13
3-1/2", 4-1/2", 5"	1.000	1-8	3/4-10	3/4-10
6", 8"	1.500	1 1/4-12	1-8	1 1/4-12

How to Order - E Series Repair Kit

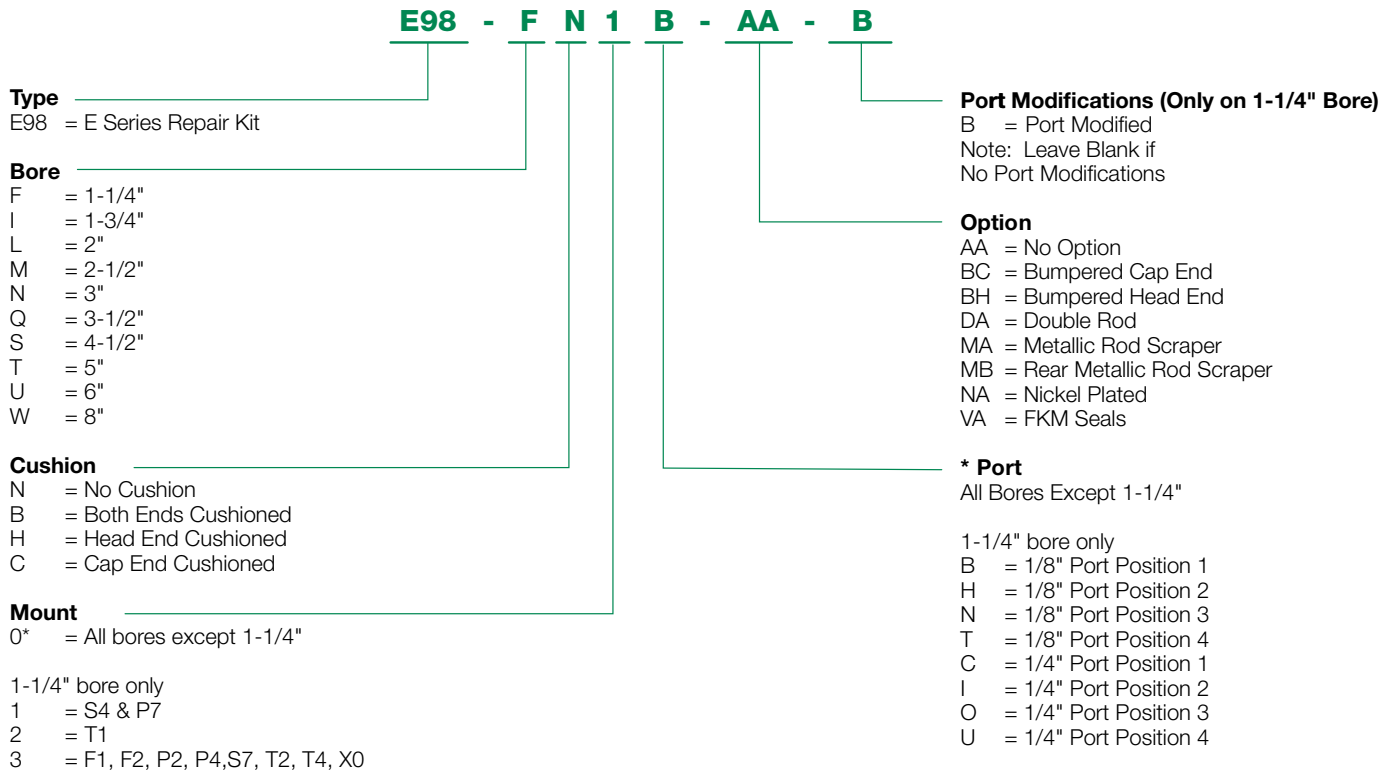

* 1-1/4" bore has pressed in bushing.

Note: Options listed are ones that apply to a repair kit only.
Model number is set up to use option code supplied with original cylinder or with any above.

How to Order - E Series Seal Kit

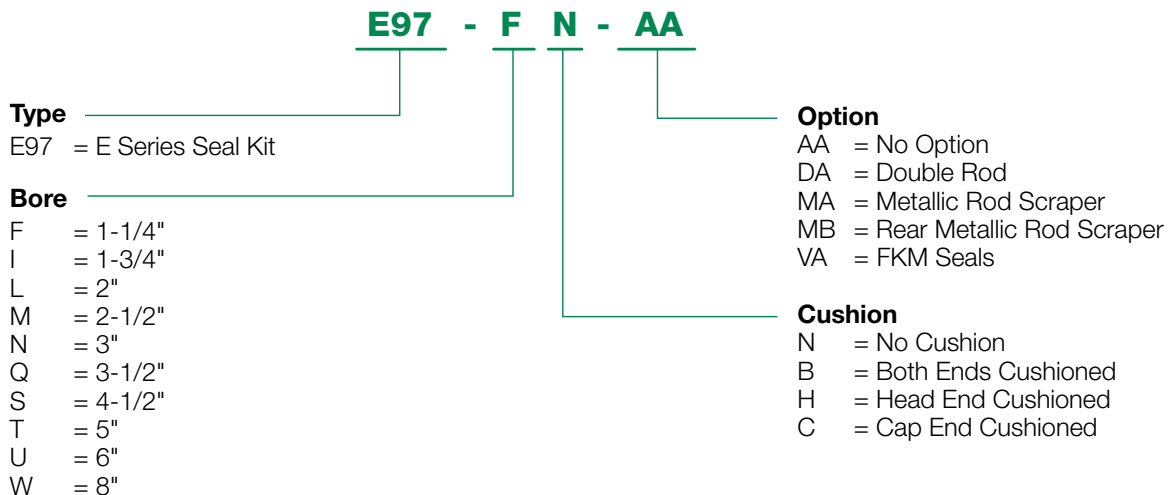

Note: Options listed are ones that apply to a seal kit only.
Model number is set up to use option code supplied with original cylinder or with any above.

Piston Rod Assembly Removal/Installation Instructions

1. Loosen 4 Sleeve Nuts (Part #8) to remove Piston/Rod Assembly (Part #16 & #19)
2. Carefully remove old seals. (Part #13 & #15) Any damage to the seal grooves may result in leakage.
3. Lubricate piston seals (Part #13) and wearband (Part #15) with supplied Numatics' Lube. Examine seals before installing for any contamination. Contamination may cause leakage.
4. Install Piston Seal (Part #13). Make sure the piston seal is not twisted inside groove. See Seal Installation Guide.
5. Install lubricated Wearband (Part #15) onto piston. Sink piston/rod assembly into sinker tube.
6. Apply lube inside the cylinder tube.
7. Sink piston/rod assembly into cylinder tube.
8. Press piston/rod assembly flush with the cylinder tube. Wipe off any lube from the face of the piston.
9. Examine seals after installing for any contamination. Contamination may cause leakage.
10. Lightly grease Rod Seal (Part #3) and Bushing O-ring (Part #2). This will ease the installation of the rod bushing over the rod and into the head.
11. Reassemble cylinder. Loosely torque Sleeve Nuts to allow head and cap to rotate slightly.
12. Before final torque, place cylinder on level surface to square head and cap. Torque Sleeve Nuts in a crisscross pattern. Use the following charts for torque tolerances for Sleeve Nuts.
13. Stroke cylinder by hand. This will enable detection of any binding. If binding does occur, repeat steps 11-13.

Seal Installation Guide

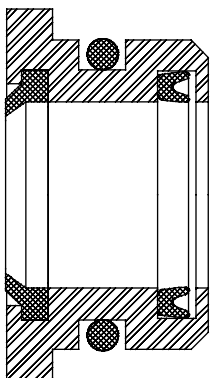

Loaded Bushing

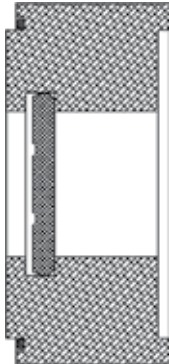

Head or Cap Cushion Block

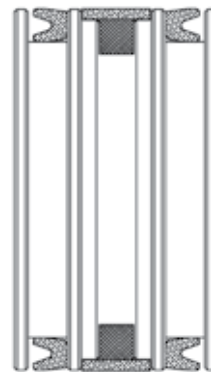

Piston

Sinker Tube Part Numbers

Bore	Part #
1-1/4"	E06-F91
1-3/4"	E06-I91
2"	A06-L91
2-1/2"	A06-M91
3"	C06-N91
3-1/2"	E06-Q91
4-1/2"	E06-S01
5"	A06-T91
6"	A06-U91
8"	A06-W91

Tie Rod Torque Tolerances (lbs-ft) Part #8

Bore	Min.	Max.
1-1/4"	8	10
1-3/4"	8	10
2"	8	10
2-1/2"	15	18
3"	15	18
3-1/2"	23	30
4-1/2"	50	60
5"	50	60
6"	50	60
8"	80	90

Note: Sinker Tubes are not included in kits. They can be ordered using the part numbers from the provided chart.

Diagrams

Pneumatic Service Temperatures:
 Nitrile Seals: -10°F (-23°C) to 165°F (74°C)
 FKM Seals: 0°F (-17°C) to 400°F (204°C)

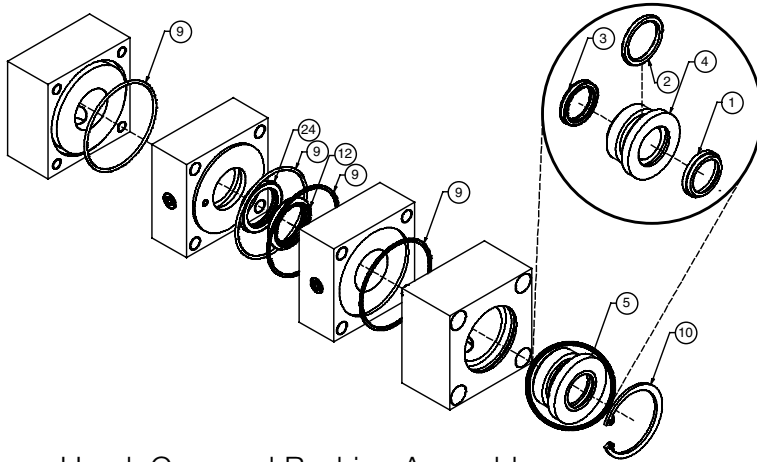

Head, Cap, and Bushing Assembly

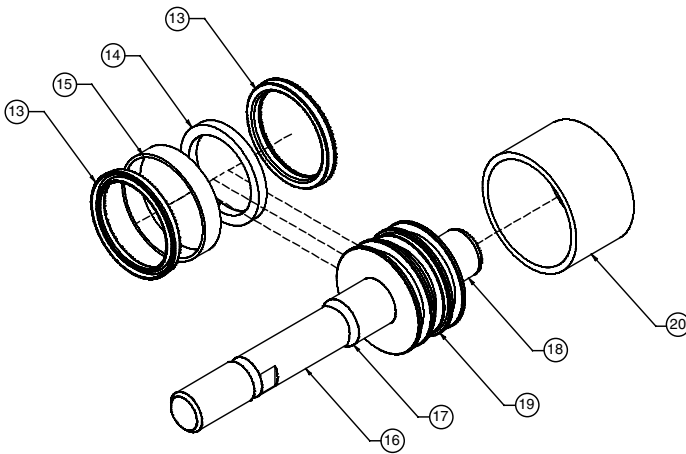

Piston/Rod Assembly

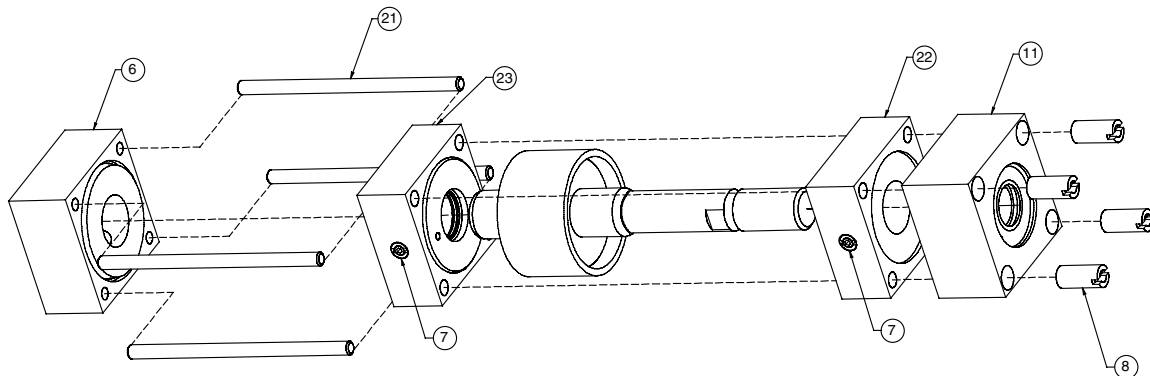

Cylinder Assembly and Tie Rod Torque

E Series

Part #	Description	Parts included in:		
		Seal Kit	Repair Kit	Piston/Rod Assembly
1	Rod Wiper	X		
2	Bushing O-ring	X		
3	Rod Seal	X		
4	Bushing			
5	Loaded Bushing Assembly		X	
6	Cap			
7	Cushion Needle			
8	Sleeve Nuts			
9	Tube End Seals	X	X	
10	Bushing Snap Ring			
11	Head			
12	Head Cushion Seal	X	X	
13	Piston Seals	X	X	
14	Magnet			X
15	Wearband	X	X	
16	Rod			X
17	Head Cushion Spear			X
18	Cap Cushion Spear			X
19	Piston			X
20	Tube			
21	Tie Rods			
22	Head Cushion Block			
23	Cap Cushion Block			
24	Cap Cushion Seal	X	X	

Repair Kit Removal/Installation Instructions

1. Remove Snap Ring (Part #10) to remove old Loaded Bushing (Part # 5)
2. Loosen 4 Sleeve Nuts (Part #8) to remove Piston/Rod Assembly (Part #16 & #19)
3. Carefully remove old seals. (Part #9, #12*, #13, #15, & #24) Any damage to the seal grooves may result in leakage.
4. Lubricate new seals with supplied Numatics' Lube. Examine seals before installing for any contamination. Contamination may cause leakage.
5. Install Piston Seal (Part #13). Make sure the piston seal is not twisted inside groove. See Seal Installation Guide.
6. Install lubricated Wearband (Part #15) onto piston. Sink piston/rod assembly into sinker tube.
7. Apply lube inside the cylinder tube.
8. Sink piston/rod assembly into cylinder tube.
9. Press piston/rod assembly flush with the cylinder tube. Wipe off any lube from the face of the piston.
10. Place Tube End Seals (Part #9) into head and cap seal grooves. If cylinder is cushioned, the kit will have additional tube end seals for the cushion block tube end seal grooves. Examine seals after installing for any contamination. Contamination may cause leakage.
11. Lightly grease Rod Seal (Part #3) and Bushing O-ring (Part #2) on the supplied loaded bushing. This will ease the installation of the rod bushing over the rod and into the head.
12. Reassemble cylinder except for loaded bushing. First, loosely torque Sleeve Nuts to allow head and cap to rotate slightly. Carefully place bushing over the rod until getting interference. With a twisting motion, slide the bushing down onto the rod and into the bushing pocket on the head.
13. Make sure loaded bushing is pressed below snap ring groove. Replace snap ring into the groove. Visually check to see if snap ring is fully seated in the groove.
14. Before final torque, place cylinder on level surface to square head and cap. Torque Sleeve Nuts in a crisscross pattern. Use the following charts for torque tolerances for Sleeve Nuts.
15. Stroke cylinder by hand. This will enable detection of any binding. If binding does occur, repeat steps 12-15.

Seal Installation Guide

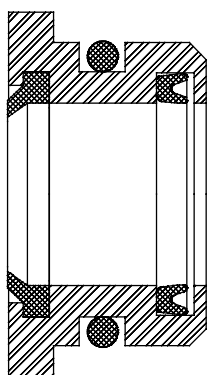

Loaded Bushing

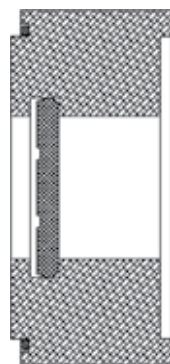

Head or Cap Cushion Block

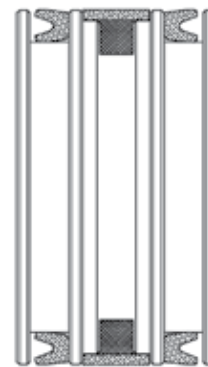

Piston

Tie Rod Torque Tolerances (lbs-ft) Part #8

Bore	Min.	Max.
1-1/4"	8	10
1-3/4"	8	10
2"	8	10
2-1/2"	15	18
3"	15	18
3-1/2"	23	30
4-1/2"	50	60
5"	50	60
6"	50	60
8"	80	90

Sinker Tube Part Numbers

Bore	Part #
1-1/4"	E06-F91
1-3/4"	E06-I91
2"	A06-L91
2-1/2"	A06-M91
3"	C06-N91
3-1/2"	E06-Q91
4-1/2"	E06-S01
5"	A06-T91
6"	A06-U91
8"	A06-W91

Note: Sinker Tubes are not included in kits. They can be ordered using the part numbers from the provided chart.

Seal Kit Removal/Installation Instructions

1. Remove Snap Ring (Part #10) to remove Loaded Bushing (Part # 5)
2. Loosen 4 Sleeve Nuts (Part #8) to remove Piston/Rod Assembly (Part #16 & #19)
3. Carefully remove old seals. (Part #1, #2, #3, #9, #12, #13, #15, & #24) Any damage to the seal grooves may result in leakage.
4. Lubricate new seals with supplied Numatics' Lube. Examine seals before installing for any contamination. Contamination may cause leakage.
5. Install Piston Seal (Part #13). Make sure the piston seal is not twisted inside groove. See Seal Installation Guide.
6. Install lubricated Wearband (Part #15) onto piston. Sink piston/rod assembly into sinker tube.
7. Apply lube inside the cylinder tube.
8. Sink piston/rod assembly into cylinder tube.
9. Press piston/rod assembly flush with the cylinder tube. Wipe off any lube from the face of the piston.
10. Place Tube End Seals (Part #9) into head and cap seal grooves. If cylinder is cushioned, the kit will have additional tube end seals for the cushion block tube end seal grooves. Examine seals after installing for any contamination. Contamination may cause leakage.
11. Install Rod Wiper (Part #1), Bushing O-ring (Part #2), and Rod Seal (Part #3) into bushing. Lightly grease Rod Seal and Bushing O-ring after installation. This will ease the installation of the rod bushing over the rod and into the head.
12. Reassemble cylinder except for loaded bushing. First, loosely torque Sleeve Nuts to allow head and cap to rotate slightly. Carefully place bushing over the rod until getting interference. With a twisting motion, slide the bushing down onto the rod and into the bushing pocket on the head.
13. Make sure loaded bushing is pressed below snap ring groove. Replace snap ring into the groove. Visually check to see if snap ring is fully seated in the groove.
14. Before final torque, place cylinder on level surface to square head and cap. Torque Sleeve Nuts in a crisscross pattern. Use the following charts for torque tolerances for Sleeve Nuts.
15. Stroke cylinder by hand. This will enable detection of any binding. If binding does occur, repeat steps 12-15.

Seal Installation Guide

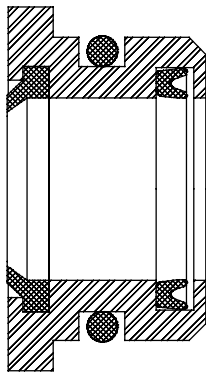

Loaded Bushing

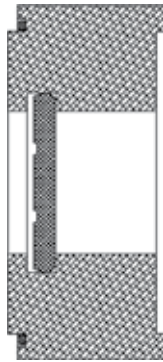

Head or Cap Cushion Block



Piston

Sinker Tube Part Numbers

Bore	Part #
1-1/4"	E06-F91
1-3/4"	E06-I91
2"	A06-L91
2-1/2"	A06-M91
3"	C06-N91
3-1/2"	E06-Q91
4-1/2"	E06-S01
5"	A06-T91
6"	A06-U91
8"	A06-W91

Note: Sinker Tubes are not included in kits. They can be ordered using the part numbers from the provided chart.

Torque Tolerances (lbs-ft) Part #8

Bore	Min.	Max.
1-1/4"	8	10
1-3/4"	8	10
2"	8	10
2-1/2"	15	18
3"	15	18
3-1/2"	23	30
4-1/2"	50	60
5"	50	60
6"	50	60
8"	80	90

E series World Switch application Detail

Round Tube and Tie Rod Detail

- 1. World Switch
- 2. Tie Rod Bracket
- 3. Adjustment Screw
- 4. Cylinder Tie Rod

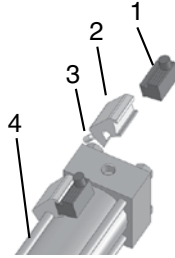

E Series World Switch Bracket

Cylinders	Bore	Part Number
E series Tie Rod	1 1/4"-2" Bore	SB6-K01
E series Tie Rod	1 3/4"-3" Bore	SB6-L01
E series Tie Rod	3 1/2"-4" Bore	SB6-P01
E series Tie Rod	4 1/2"-6"	SB6-T01
E series Tie Rod	8" Bore	SB6-W01

E Series World Switch Hall Effect Part Numbers

P/N	Switch Style	Electrical Design	Output	Operating Voltage	Current Rating	Switching Power	Voltage Drop	NEMA IP Rating	Temperature Rating
SH6-031	Flying Lead	DC PNP	Normally Open	6-24 VDC	0.3 Amps Max.	7.2 Watts Max.	.5 Volts	NEMA 6	-25° to +75° C
SH6-032	Flying Lead	DC PNP	Normally Open	6-24 VDC	0.3 Amps Max.	7.2 Watts Max.	.5 Volts	NEMA 6	-25° to +75° C
SH6-021	M8 Connector	DC NPN	Normally Open	6-24 VDC	0.3 Amps Max.	7.2 Watts Max.	.5 Volts	NEMA 6	-25° to +75° C
SH6-022	M8 Connector	DC NPN	Normally Open	6-24 VDC	0.3 Amps Max.	7.2 Watts Max.	.5 Volts	NEMA 6	-25° to +75° C

Hall Effect Switch

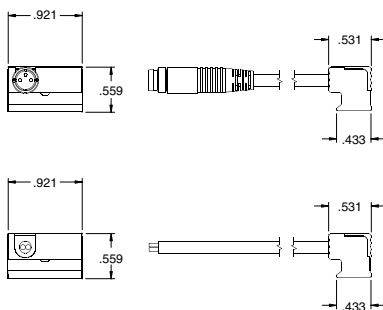

PNP Sourcing

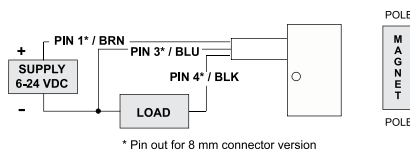

NPN Sinking

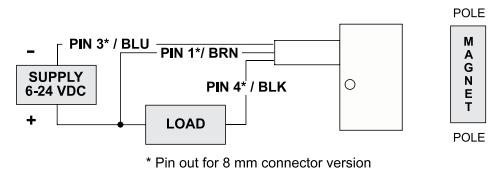

E Series World Switch Reed Switch Part Numbers

P/N	Switch Style	Electrical Design	Output	Operating Voltage	Current Rating	Switching Power	Voltage Drop	NEMA IP Rating	Temperature Rating
SR6-002	Flying Lead	AC/DC REED	Normally Open	5-120 VAC/DC	0.025 Amps Max. 0.001 Amps Min.	3 Watts Max.	3.5 Volts	NEMA 6	-25° to +75° C
SR6-004	Flying Lead	AC/DC REED	Normally Open	5-120 VAC/DC	0.5 Amps Max. 0.005 Amps Min.	10 Watts Max.	3.0 Volts	NEMA 6	-25° to +75° C
SR6-022	M8 Connector	AC/DC REED	Normally Open	5-50 VAC 5-60 VDC	0.025 Amps Max. 0.001 Amps Min.	3 Watts Max.	.5 Volts	NEMA 6	-25° to +75° C
SR6-024	M8 Connector	AC/DC REED	Normally Open	5-50 VAC 5-60 VDC	0.5 Amps Max. 0.005 Amps Min.	10 Watts Max.	3.0 Volts	NEMA 6	-25° to +75° C

Reed Switch - Normally Open Type SR6

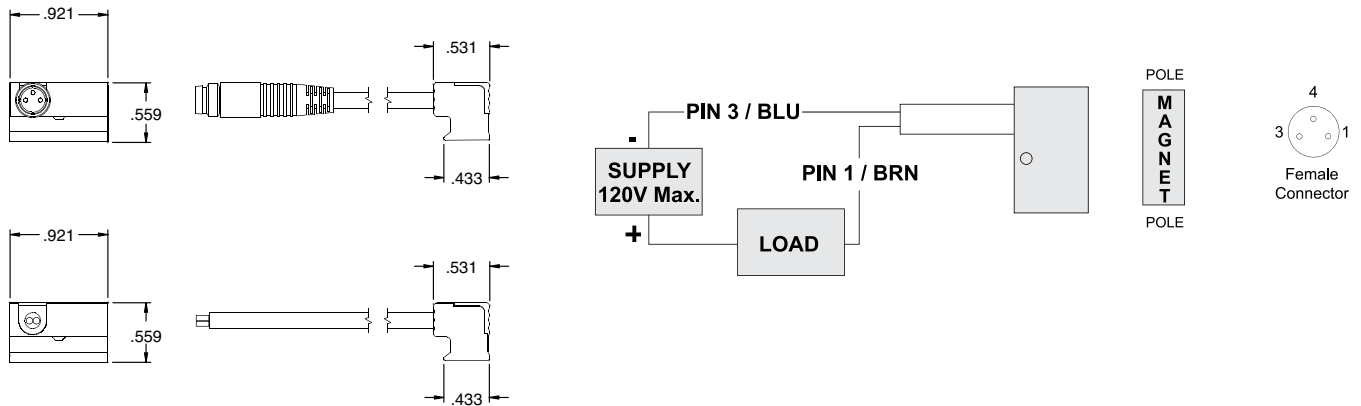

Specialty Cylinders

E Series (Tie Rod)

Bore	Bracket P/N
1 1/4"	N99-1181
1 3/4"	N99-1182
2"	N99-1181
2 1/2"	N99-1182
3"	N99-1182
3 1/2"	N99-1183
4 1/2"	N99-1184
5"	N99-1184
6"	N99-1184
8"	N99-1184

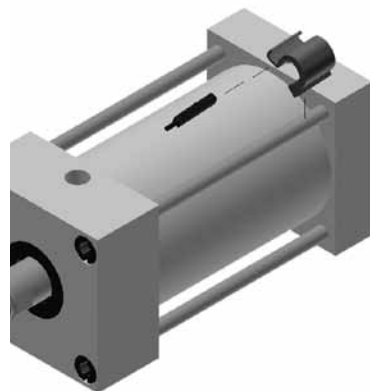

Sensor Description	Standard Cord Set	Quick Disconnect
Reed Switch	REED-FL2-00	REED-QDS-M8U
Hall PNP	PNP-FL2-00-U	PNP-QDS-M8-U
Hall NPN	NPN-FL2-00-U	NPN-QDS-M8-U

See page 22, 23, & 24 for sensor specifications

Sensing Part Numbers

PNP-FL2-00-U

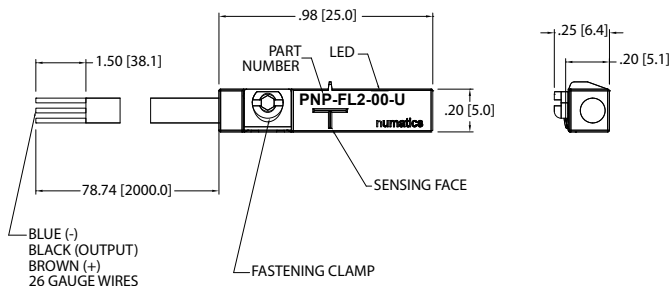

PNP-QDS-M8-U

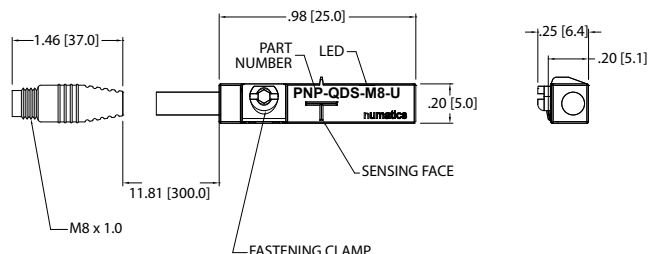





ELECTRICAL DESIGN	DC PNP
OUTPUT	Normally Open
OPERATING VOLTAGE	10-30 VDC
CURRENT RATING	100 mA
SHORT-CIRCUIT PROTECTION	Yes
OVERLOAD PROTECTION	Yes
REVERSE POLARITY PROTECTION	Yes
VOLTAGE DROP	< 2.5 V
CURRENT CONSUMPTION	< 12 mA
REPEATABILITY	< .2mm
POWER-ON DELAY TIME	< 30 ms
SWITCH FREQUENCY	> 3000 Hz
AMBIENT TEMPERATURE	-25°C to 85°C
PROTECTION	IP 67, III
HYSTERESIS	1.0mm
MAGNETIC SENSITIVITY	2.0 mT
TRAVEL SPEED	> 10 m/s
HOUSING MATERIAL	PA (Polyamide) Black; Fastening Clamp: Stainless Steel
FUNCTION DISPLAY SWITCHING STATUS	Yellow LED
CONNECTION	Flying Leads, Pur Cable (2m Long, 3 x26 Gauge Wire)
REMARKS	Clamping Screw with Combined Slot/Hexagon Socket Head AF 1.5 cULus - Class 2 Source Required
ACCESSORIES	Rubber Placeholder, Cable Clip, and Cut Sheet To Be Provided with Every Switch
AGENCY APPROVALS	CE cUL us RoHS

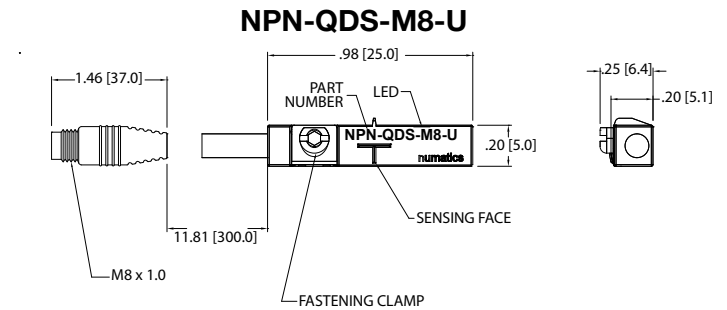
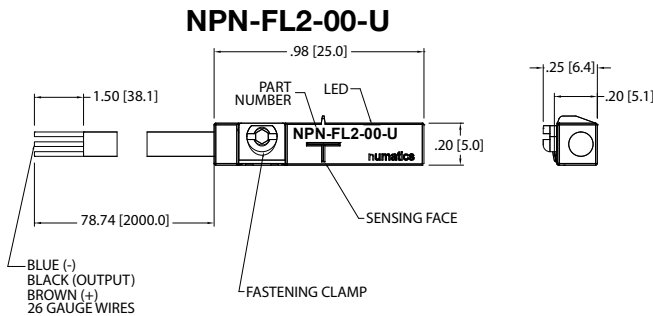

ELECTRICAL DESIGN	DC PNP
OUTPUT	Normally Open
OPERATING VOLTAGE	10-30 VDC
CURRENT RATING	100 mA
SHORT-CIRCUIT PROTECTION	Yes
OVERLOAD PROTECTION	Yes
REVERSE POLARITY PROTECTION	Yes
VOLTAGE DROP	< 2.5 V
CURRENT CONSUMPTION	< 12 mA
REPEATABILITY	< .2mm
POWER-ON DELAY TIME	< 30 ms
SWITCH FREQUENCY	> 3000 Hz
AMBIENT TEMPERATURE	-25°C to 85°C
PROTECTION	IP 67, III
HYSTERESIS	1.0mm
MAGNETIC SENSITIVITY	2.0 mT
TRAVEL SPEED	> 10 m/s
HOUSING MATERIAL	PA (Polyamide) Black; Fastening Clamp: Stainless Steel
FUNCTION DISPLAY SWITCHING STATUS	Yellow LED
CONNECTION	M8 Connector (Snap Fit) , Pur Cable (.3 m)
REMARKS	Clamping Screw with Combined Slot/Hexagon Socket Head AF 1.5 cULus - Class 2 Source Required
ACCESSORIES	Rubber Placeholder, Cable Clip, and Cut Sheet To Be Provided with Every Switch
AGENCY APPROVALS	CE cUL us RoHS

*Switches are not designed for wet environments. Please see your distributor for additional information.

Sensing Part Numbers



ELECTRICAL DESIGN	DC NPN
OUTPUT	Normally Open
OPERATING VOLTAGE	10-30 VDC
CURRENT RATING	100 mA
SHORT-CIRCUIT PROTECTION	Yes
OVERLOAD PROTECTION	Yes
REVERSE POLARITY PROTECTION	Yes
VOLTAGE DROP	< 2.5 V
CURRENT CONSUMPTION	< 12 mA
REPEATABILITY	< .2mm
POWER-ON DELAY TIME	< 30 ms
SWITCH FREQUENCY	> 3000 Hz
AMBIENT TEMPERATURE	-25°C to 85°C
PROTECTION	IP 67, III
HYSTERESIS	1.0mm
MAGNETIC SENSITIVITY	2.0 mT
TRAVEL SPEED	> 10 m/s
HOUSING MATERIAL	PA (Polyamide) Black; Fastening Clamp: Stainless Steel
FUNCTION DISPLAY SWITCHING STATUS	Yellow LED
CONNECTION	Flying Leads, Pur Cable (2m Long, 3 x26 Gauge Wire)
REMARKS	Clamping Screw with Combined Slot/Hexagon Socket Head AF 1.5 cULus - Class 2 Source Required
ACCESSORIES	Rubber Placeholder, Cable Clip, and Cut Sheet To Be Provided with Every Switch
AGENCY APPROVALS	  

ELECTRICAL DESIGN	DC NPN
OUTPUT	Normally Open
OPERATING VOLTAGE	10-30 VDC
CURRENT RATING	100 mA
SHORT-CIRCUIT PROTECTION	Yes
OVERLOAD PROTECTION	Yes
REVERSE POLARITY PROTECTION	Yes
VOLTAGE DROP	< 2.5 V
CURRENT CONSUMPTION	< 12 mA
REPEATABILITY	< .2mm
POWER-ON DELAY TIME	< 30 ms
SWITCH FREQUENCY	> 3000 Hz
AMBIENT TEMPERATURE	-25°C to 85°C
PROTECTION	IP 67, III
HYSTERESIS	1.0mm
MAGNETIC SENSITIVITY	2.0 mT
TRAVEL SPEED	> 10 m/s
HOUSING MATERIAL	PA (Polyamide) Black; Fastening Clamp: Stainless Steel
FUNCTION DISPLAY SWITCHING STATUS	Yellow LED
CONNECTION	M8 Connector (Snap Fit) , Pur Cable (.3 m)
REMARKS	Clamping Screw with Combined Slot/Hexagon Socket Head AF 1.5 cULus - Class 2 Source Required
ACCESSORIES	Rubber Placeholder, Cable Clip, and Cut Sheet To Be Provided with Every Switch
AGENCY APPROVALS	  

*Switches are not designed for wet environments. Please see your distributor for additional information.

Sensing Part Numbers

REED-FL2-00

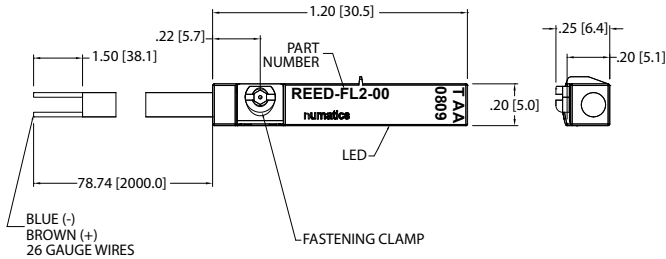

REED-QDS-M8U

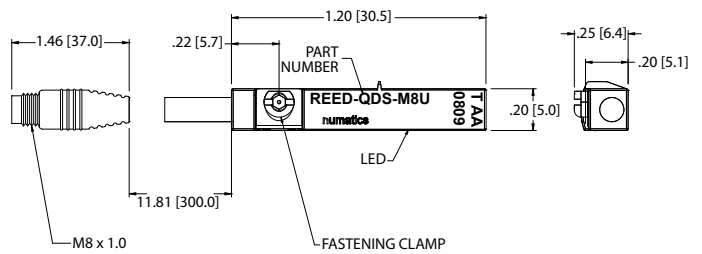

ELECTRICAL DESIGN	AC/DC REED
OUTPUT	Normally Open
OPERATING VOLTAGE	5-120 VAC/DC
CURRENT RATING	100 mA*
SHORT-CIRCUIT PROTECTION	No
OVERLOAD PROTECTION	No
REVERSE POLARITY PROTECTION	Yes
VOLTAGE DROP	< 5 V
REPEATABILITY	± .2mm
MAKETIME INCLUDING BOUNCE	< .6 ms
BREAKTIME	< .1 ms
SWITCHING POWER (MAX)	5 W
SWITCH FREQUENCY	1000 Hz
AMBIENT TEMPERATURE	-25°C to 70°C
PROTECTION	IP 67, II
HYSTERESIS	.9mm
HOUSING MATERIAL	PA (Polyamide) Black; Fastening Clamp: Stainless Steel
FUNCTION DISPLAY SWITCHING STATUS	Yellow LED
CONNECTION	Flying Leads, Pur Cable (2m Long, 2 x26 Gauge Wire)
REMARKS	*External Protective Circuit for Inductive Load (Valve, Contactor, Etc..) Necessary. Conforms to 2008 NEC Section 725 III, Class 2 Circuits Clamping Screw with Combined Slot/Hexagon Socket Head AF 1.5. No LED Function in case of Polarity in DC Operation
ACCESSORIES	Rubber Placeholder, Cable Clip, and Cut Sheet To Be Provided with Every Switch
AGENCY APPROVALS	CE RoHS

ELECTRICAL DESIGN	AC/DC REED
OUTPUT	Normally Open
OPERATING VOLTAGE	*5-60 VDC / 5-50 VAC
CURRENT RATING	100 mA
SHORT-CIRCUIT PROTECTION	No
OVERLOAD PROTECTION	No
REVERSE POLARITY PROTECTION	Yes
VOLTAGE DROP	< 5 V
REPEATABILITY	± .2mm
MAKETIME INCLUDING BOUNCE	< .6 ms
BREAKTIME	< .1 ms
SWITCHING POWER (MAX)	5 W
SWITCH FREQUENCY	1000 Hz
AMBIENT TEMPERATURE	-25°C to 70°C
PROTECTION	IP 67, II
HYSTERESIS	.9mm
HOUSING MATERIAL	PA (Polyamide) Black; Fastening Clamp: Stainless Steel
FUNCTION DISPLAY SWITCHING STATUS	Yellow LED
CONNECTION	M8 Connector (Snap Fit), Pur Cable (.3m)
REMARKS	*External Protective Circuit for Inductive Load (Valve, Contactor, Etc..) Necessary. Conforms to 2008 NEC Section 725 III, Class 2 Circuits M8 Connector voltage limited to 5-60 vdc / 5-50 vac to conform with 2008 IEC 61076-2-104 Clamping Screw with Combined Slot/Hexagon Socket Head AF 1.5. No LED Function in case of Polarity in DC Operation
ACCESSORIES	Rubber Placeholder, Cable Clip, and Cut Sheet To Be Provided with Every Switch
AGENCY APPROVALS	CE RoHS

*Switches are not designed for wet environments. Please see your distributor for additional information.

Quick Disconnect Cables

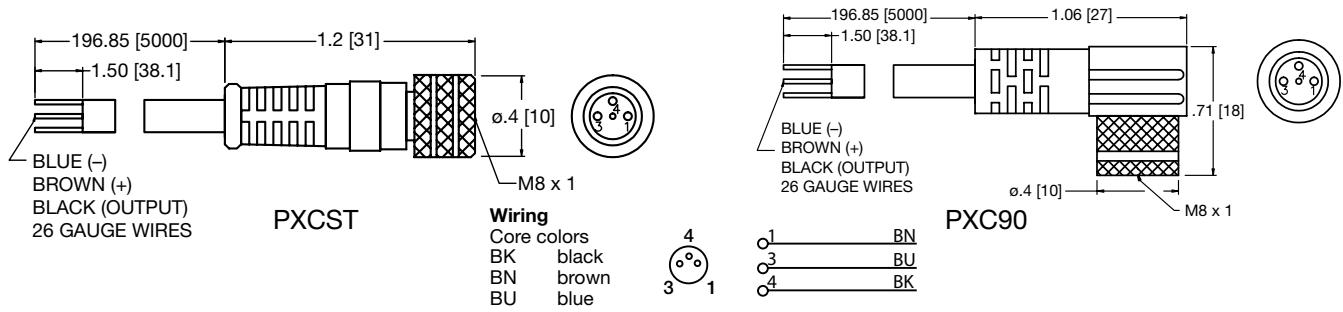

Order Code	Type	Operating Voltage	Current Rating	Cable Material	Protection	Connector
PXCST	Straight 5 m Cable (3 x 26 Gauge wire)	60 AC/75 DC	3 A	PUR	IP 68, III	M8
PXC90	90° 5 m Cable (3 x 26 Gauge wire)	60 AC/75 DC	3 A	PUR	IP 68, III	M8

NUMATICS®

World Class Supplier of Pneumatic Components



World Headquarters

USA Numatics, Incorporated

46280 Dylan Drive
Novi, Michigan 48377

P: 248-596-3200
F: 248-596-3201

Canada Numatics, Ltd

P: 519-758-2700
F: 519-758-5540

México - Ascomatica SA de CV

P: 52 55 58 09 56 40 (DF y Area metropolitana)
P: 01 800 000 ASCO (2726) (Interior de la República)
F: 52 55 58 09 56 60

Brazil Ascoval Ind.e Comercio Ltda

P: (55) 11-4208-1700
F: (55) 11-4195-3970