



**SLIDE-RITE™ GEARBOX and  
SLIDE-RITE™CR GEARBOX**  
Pages 2 through 7



**FLOAT-A-SHAFT (FAS) GEARBOX**  
Pages 8 through 24

Visit [www.tolomatic.com](http://www.tolomatic.com) for the latest updates, CAD files and ordering.

- SLIDE-RITE GEARBOX
- ENDURANCE TECHNOLOGY
- APPLICATION EXAMPLE
- COMPACT SERIES 1:1 RATIO
- STANDARD SERIES 1:1 RATIO
- STANDARD SERIES 3:2 RATIO
- STANDARD SERIES 2:1 RATIO
- FLOAT-A-SHAFT
- APPLICATIONS
- INTRODUCTION
- COMPACT SERIES 1:1 RATIO
- STANDARD SERIES 1:1 RATIO
- STANDARD SERIES 3:2 RATIO
- STANDARD SERIES 2:1 RATIO
- STANDARD SERIES 2.5:1 RATIO
- SELECTION
- INSTALLATION
- SHAFT & KEYWAY REQUIREMENTS

# Slide-Rite® & Slide-Rite®CR Gearbox

SLIDE-RITE GEARBOX

ENDURANCE TECHNOLOGY

APPLICATION EXAMPLE

COMPACT SERIES 1:1 RATIO

STANDARD SERIES 1:1 RATIO

STANDARD SERIES 3:2 RATIO

STANDARD SERIES 2:1 RATIO

FLOAT-A-SHAFT

APPLICATIONS

INTRODUCTION

COMPACT SERIES 1:1 RATIO

STANDARD SERIES 1:1 RATIO

STANDARD SERIES 3:2 RATIO

STANDARD SERIES 2:1 RATIO

STANDARD SERIES 2.5:1 RATIO

SELECTION

INSTALLATION

SHAFT & KEYWAY REQUIREMENTS

## COMPACT SIZE & STANDARD SIZE

The **Slide-Rite®**, like the classic **Float-A-Shaft®**, is a universal right angle gearbox. It consists of two 45° helical gears that mesh at right angles, designed to turn power at 90°. It can be operated in either direction and can slide axially along the drive or driven shaft.

The **Slide-Rite®** gearbox's unique floating design maintains perfect shaft alignment allowing for easy installation.

A solid one-piece aluminum housing seals the gears from outside contaminants, providing for smooth operation in even the harshest industrial environments.

### ENDURANCE TECHNOLOGY<sup>SM</sup>

Look for this endurance technology symbol indicating our durability design features

#### LEAK-PROOF PERFORMANCE

- One-piece housing, one-piece geared shaft and sealed bearings offer leak-proof performance and excellent service life

#### PRELUBRICATED

- Prelubricated for long, trouble-free service

#### ONE-PIECE GEARED SHAFT

- Fewer parts to wear out

#### USES STANDARD TRANSMISSION SHAFTING

#### HARD COATED ALUMINUM CASE

- Resists corrosion and forms its own lubricant reservoir

#### THREADED MOUNTING HOLES

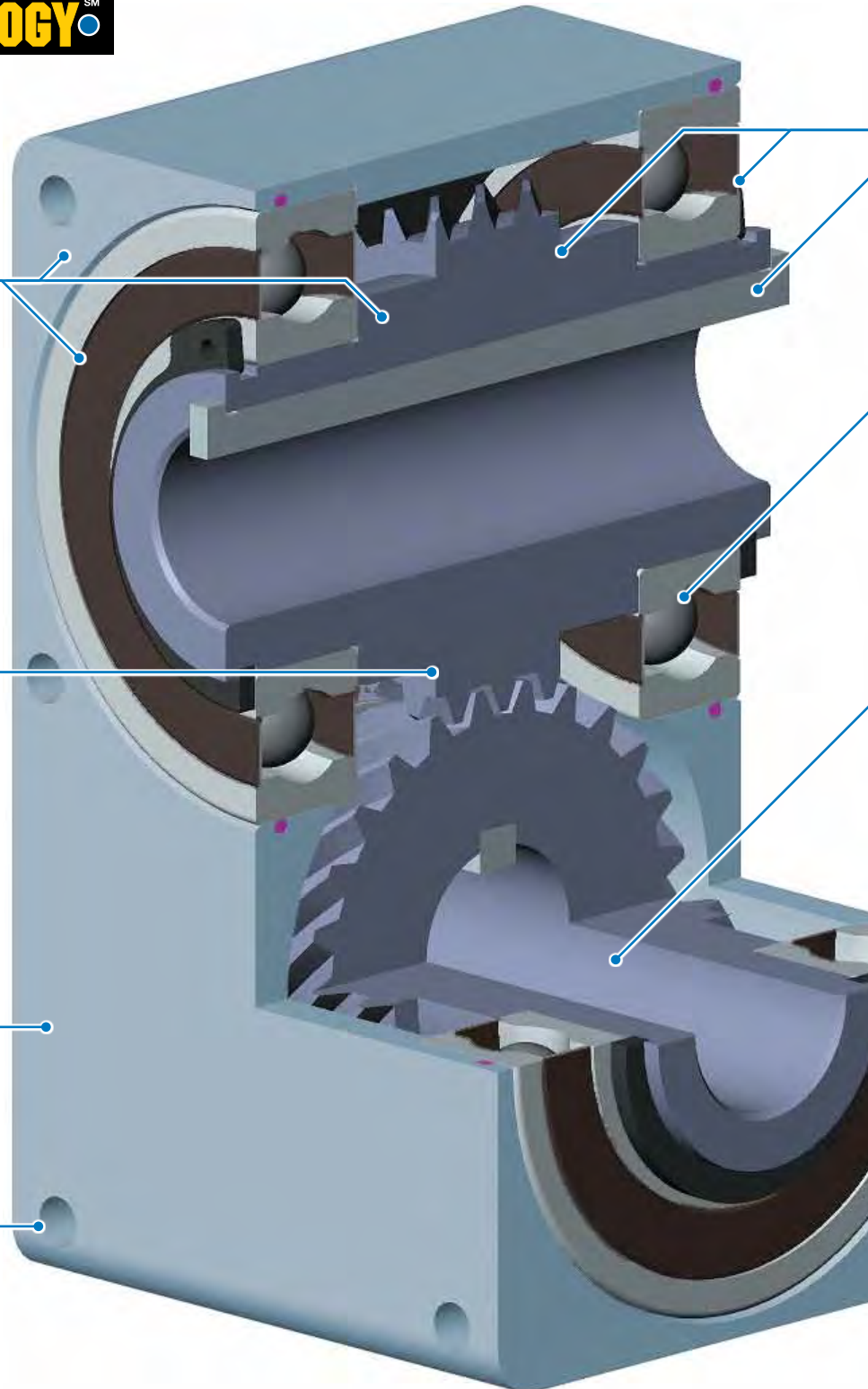

## APPLICATION EXAMPLE

The specially selected corrosion resistant components of the **Slide-Rite®CR** Gearbox make it the perfect choice for environmentally challenging applications.

### SLIDE-RITE®CR FEATURES:

#### • HELICAL GEARS, KEYS, RETAINING RINGS •

##### • ALLOY STEEL •

- 45 degree helical gears are hardened alloy steel
- High performance, long life construction

##### • NICKEL PLATED •

- Corrosion resistant electroless nickel-plated geared sleeves, keys and retaining rings

#### • BEARINGS AND BEARING RACES •

##### • HARDENED STEEL •

- High performance, long life materials

##### • STAINLESS STEEL •

- Corrosion resistant stainless steel balls and races

#### • PRECISION GROUND BORES •

#### • SPECIFICATIONS •

- Max speed: 1,200 RPM
- Backlash: < 1 degree
- Bidirectional
- Slide through bore: limited only by length of keyway on shaft

Specifications and endurance technology features apply to all sizes of Slide-Rite® gearboxes.

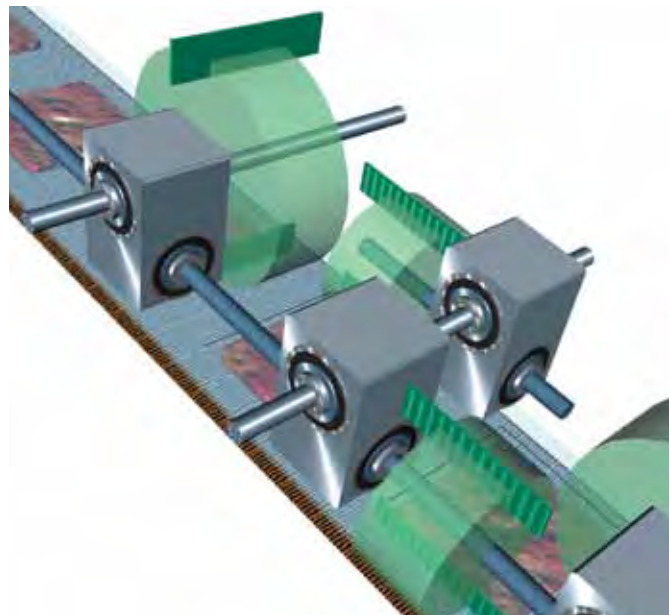

#### **Application Description:**

A manufacturer of frozen pizzas needed a way to cut and seal the plastic packaging for multiple sizes of their signature square pizza.

#### **Application Requirements:**

- Output of 60 pizzas per minute
- 4" adjustment range
- No maintenance - washdown environment

#### **Tolomatic Solution: Slide-Rite®CR Gearboxes**

The sealed, high speed, corrosion resistant design of the Slide-Rite®CR provides the high throughput necessary in this application. Other important application design features: Using multiple right angle gearboxes, a single motor, located outside the wash down area, synchronously drives both cutting and sealing units. The slide through bore feature of the Slide-Rite® offers adjustability for several pizza sizes.

## COMPACT SIZE – 1:1 RATIO – U.S. & METRIC

### AVAILABLE STYLES

1:1 US STANDARD  
1:1 METRIC

1:1 SLIDE-RITE®CR; US STANDARD



### DIMENSIONS

Model Builder 3D CAD Available at: [www.tolomatic.com](http://www.tolomatic.com)

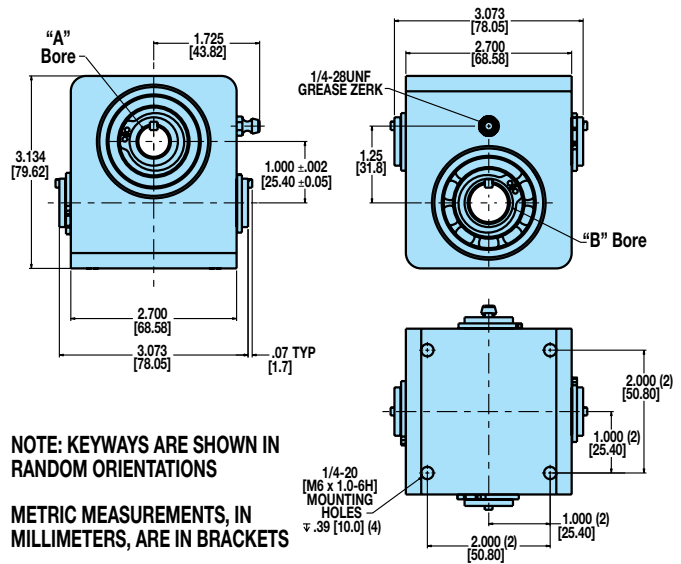

### PERFORMANCE DATA

#### High Torque Ball Bearings

#### Torque and Efficiency vs RPM at Maximum Operating Temperature

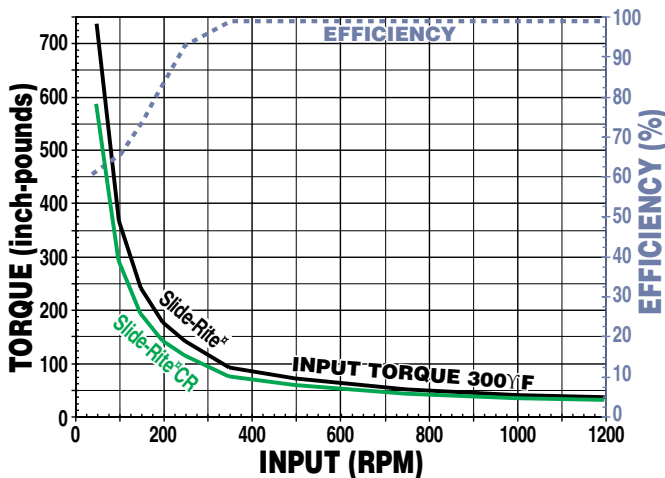

#### Models and Bore Dimensions

#### COMPACT SIZE – 1:1 RATIO – U.S. HIGH TORQUE BALL BEARING

SLIDE-RITE® MODEL NUMBER	SLIDE-RITE®CR MODEL NUMBER	RH or LH	"A" BORE		"B" BORE		APPROX. WEIGHT (LBS.)
			BORE SIZE (IN.)	WxD KEYWAY (IN.)	BORE SIZE (IN.)	WxD KEYWAY (IN.)	
0120-0400	0120-0420	RH	1/2	1/8 x 1/16	1/2	1/8 x 1/16	2.7
0121-0400	0121-0420	LH	1/2	1/8 x 1/16	1/2	1/8 x 1/16	2.7
0122-0400	0122-0420	RH	1/2	1/8 x 1/16	5/8	1/8 x 1/16	2.6
0123-0400	0123-0420	LH	1/2	1/8 x 1/16	5/8	1/8 x 1/16	2.6
0124-0400	0124-0420	RH	5/8	1/8 x 1/16	5/8	1/8 x 1/16	2.5
0125-0400	0125-0420	LH	5/8	1/8 x 1/16	5/8	1/8 x 1/16	2.5

#### COMPACT SIZE – 1:1 RATIO – METRIC HIGH TORQUE BALL BEARING

MODEL NUMBER	RH or LH	"A" BORE		"B" BORE		APPROX. WEIGHT (kg.)
		BORE SIZE (mm)	WxD KEYWAY (mm)	BORE SIZE (mm)	WxD KEYWAY (mm)	
0120-0410	RH	12	4 x 2	12	4 x 2	1.2
0121-0410	LH	12	4 x 2	12	4 x 2	1.2
0122-0410	RH	12	4 x 2	15	5 x 2.5	1.2
0123-0410	LH	12	4 x 2	15	5 x 2.5	1.2
0124-0410	RH	15	5 x 2.5	15	5 x 2.5	1.1
0125-0410	LH	15	5 x 2.5	15	5 x 2.5	1.1

# Slide-Rite® & Slide-Rite®CR Gearbox

## STANDARD SIZE – 1:1 RATIO – U.S. & METRIC

### AVAILABLE STYLES

1:1 US STANDARD  
1:1 METRIC



1:1 SLIDE-RITE®CR; US STANDARD



### PERFORMANCE DATA

**High Torque Ball Bearings**  
**Torque and Efficiency vs RPM**  
**at Maximum Operating Temperature**

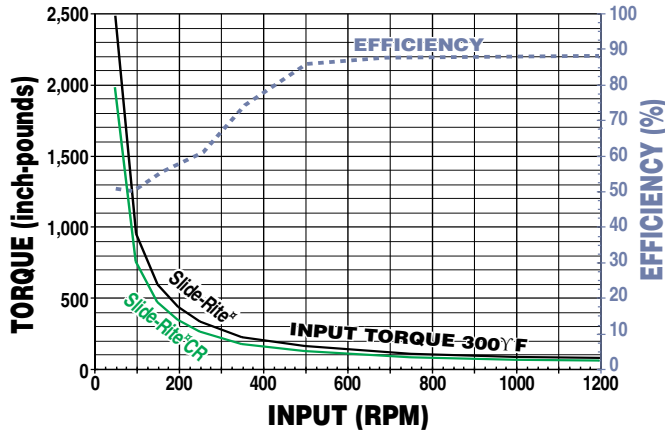

### Models and Bore Dimensions

#### STANDARD SIZE – 1:1 RATIO – U.S. HIGH TORQUE BALL BEARING

SLIDE-RITE® MODEL NUMBER	SLIDE-RITE®CR MODEL NUMBER	RH or LH	"A" BORE			"B" BORE			APPROX. WEIGHT (LBS.)
			BORE SIZE (IN.)	WxD (IN.)	"C" KEYWAY DIM. (IN.)	BORE SIZE (IN.)	WxD (IN.)	"D" KEYWAY DIM. (IN.)	
0220-0400	0220-0420	RH	3/4	3/16 x 3/32	.10	3/4	3/16 x 3/32	.10	10.7
0221-0400	0221-0420	LH	3/4	3/16 x 3/32	.10	3/4	3/16 x 3/32	.10	10.7
0222-0400	0222-0420	RH	3/4	3/16 x 3/32	.10	1	1/4 x 1/8	.13	10.4
0223-0400	0223-0420	LH	3/4	3/16 x 3/32	.10	1	1/4 x 1/8	.13	10.4
0224-0400	0224-0420	RH	3/4	3/16 x 3/32	.10	1-1/4	1/4 x 1/8	.13	9.9
0225-0400	0225-0420	LH	3/4	3/16 x 3/32	.10	1-1/4	1/4 x 1/8	.13	9.9
0226-0400	0226-0420	RH	1	1/4 x 1/8	.13	1	1/4 x 1/8	.13	10.0
0227-0400	0227-0420	LH	1	1/4 x 1/8	.13	1	1/4 x 1/8	.13	10.0
0228-0400	0228-0420	RH	1	1/4 x 1/8	.13	1-1/4	1/4 x 1/8	.13	9.6
0229-0400	0229-0420	LH	1	1/4 x 1/8	.13	1-1/4	1/4 x 1/8	.13	9.6
0230-0400	0230-0420	RH	1-1/4	1/4 x 1/8	.13	1-1/4	1/4 x 1/8	.13	9.1
0231-0400	0231-0420	LH	1-1/4	1/4 x 1/8	.13	1-1/4	1/4 x 1/8	.13	9.1

### DIMENSIONS

Model Builder 3D CAD Available at: [www.tolomatic.com](http://www.tolomatic.com)

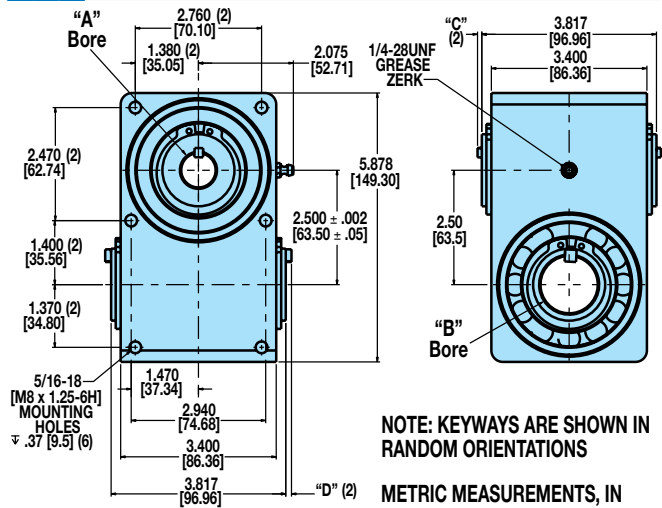

#### STANDARD SIZE – 1:1 RATIO – METRIC HIGH TORQUE BALL BEARING

MODEL NUMBER	RH or LH	"A" BORE			"B" BORE			APPROX. WEIGHT (kg.)
		BORE SIZE (mm)	WxD (mm)	"C" KEYWAY DIM. (mm)	BORE SIZE (mm)	WxD (mm)	"D" KEYWAY DIM. (mm)	
0220-0410	RH	20	6 x 3	3.2	20	6 x 3	3.2	4.8
0221-0410	LH	20	6 x 3	3.2	20	6 x 3	3.2	4.8
0222-0410	RH	20	6 x 3	3.2	25	8 x 3.5	3.2	4.7
0223-0410	LH	20	6 x 3	3.2	25	8 x 3.5	3.2	4.7
0224-0410	RH	20	6 x 3	3.2	30	8 x 3.5	3.2	4.5
0225-0410	LH	20	6 x 3	3.2	30	8 x 3.5	3.2	4.5
0226-0410	RH	25	8 x 3.5	3.2	25	8 x 3.5	3.2	4.5
0227-0410	LH	25	8 x 3.5	3.2	25	8 x 3.5	3.2	4.5
0228-0410	RH	25	8 x 3.5	3.2	30	8 x 3.5	3.2	4.4
0229-0410	LH	25	8 x 3.5	3.2	30	8 x 3.5	3.2	4.4
0230-0410	RH	30	8 x 3.5	3.2	30	8 x 3.5	3.2	4.2
0231-0410	LH	30	8 x 3.5	3.2	30	8 x 3.5	3.2	4.2

GEARBOXES

SLIDE-RITE  
GEARBOX

ENDURANCE  
TECHNOLOGY

APPLICATION  
EXAMPLE

COMPACT  
SERIES  
1:1 RATIO

STANDARD  
SERIES  
1:1 RATIO

STANDARD  
SERIES  
3:2 RATIO

STANDARD  
SERIES  
2:1 RATIO

FLOAT-A-  
SHAFT

APPLICATIONS

INTRODUCTION

COMPACT  
SERIES  
1:1 RATIO

STANDARD  
SERIES  
1:1 RATIO

STANDARD  
SERIES  
3:2 RATIO

STANDARD  
SERIES  
2:1 RATIO

STANDARD  
SERIES  
2.5:1 RATIO

SELECTION

INSTALLATION

SHAFT &  
KEYWAY  
REQUIREMENTS

## STANDARD SIZE – 3:2 RATIO – U.S.

SLIDE-RITE GEARBOX

ENDURANCE TECHNOLOGY

APPLICATION EXAMPLE

COMPACT SERIES 1:1 RATIO

STANDARD SERIES 1:1 RATIO

STANDARD SERIES 3:2 RATIO

STANDARD SERIES 2:1 RATIO

FLOAT-A-SHAFT

APPLICATIONS

INTRODUCTION

COMPACT SERIES 1:1 RATIO

STANDARD SERIES 1:1 RATIO

STANDARD SERIES 3:2 RATIO

STANDARD SERIES 2:1 RATIO

STANDARD SERIES 2.5:1 RATIO

SELECTION

INSTALLATION

SHAFT & KEYWAY REQUIREMENTS

### AVAILABLE STYLES

3:2 US STANDARD



### DIMENSIONS

Model Builder 3D CAD Available at: [www.tolomatic.com](http://www.tolomatic.com)

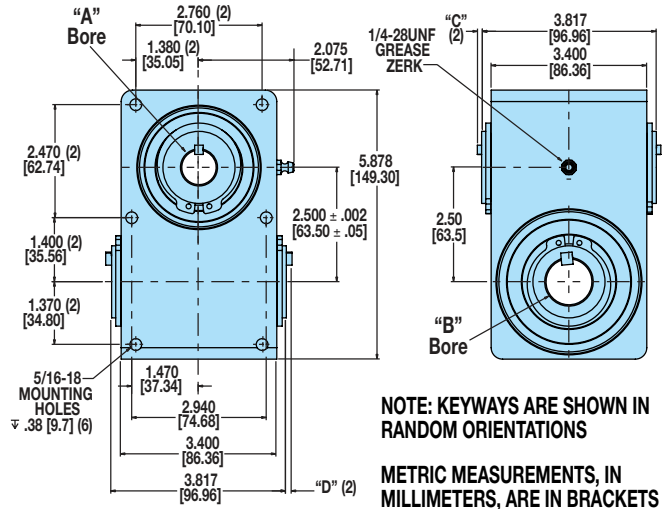

### PERFORMANCE DATA

#### High Torque Ball Bearings

#### Torque and Efficiency vs RPM at Maximum Operating Temperature

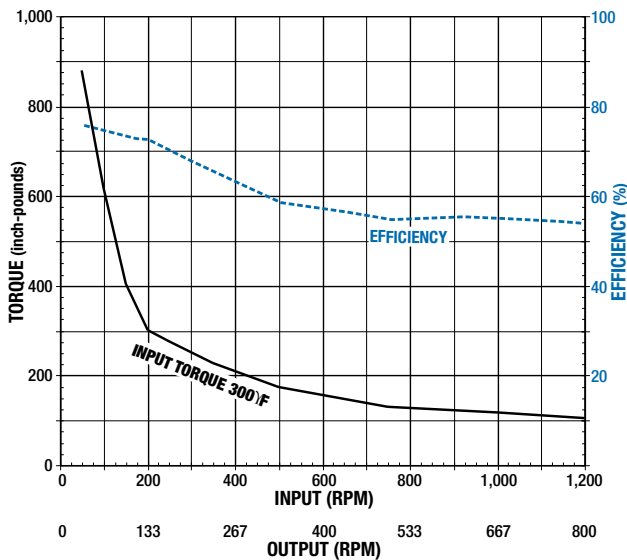

#### Models and Bore Dimensions

#### STANDARD SIZE – 3:2 RATIO – U.S. HIGH TORQUE BALL BEARING

MODEL NUMBER	RH or LH	"A" BORE			"B" BORE			APPROX. WEIGHT (LBS.)
		BORE SIZE (IN.)	WxD (IN.)	"C" DIM. (IN.)	BORE SIZE (IN.)	WxD (IN.)	"D" DIM. (IN.)	
0320-0460	RH	3/4	3/16 x 3/32	.10	3/4	3/16 x 3/32	.10	10.3
0321-0460	LH	3/4	3/16 x 3/32	.10	3/4	3/16 x 3/32	.10	10.3
0322-0460	RH	3/4	3/16 x 3/32	.10	1	1/4 x 1/8	.13	10.0
0323-0460	LH	3/4	3/16 x 3/32	.10	1	1/4 x 1/8	.13	10.0
0324-0460	RH	3/4	3/16 x 3/32	.10	1-1/4	1/4 x 1/8	.13	9.5
0325-0460	LH	3/4	3/16 x 3/32	.10	1-1/4	1/4 x 1/8	.13	9.5
0326-0460	RH	1	1/4 x 1/8	.13	1	1/4 x 1/8	.13	9.6
0327-0460	LH	1	1/4 x 1/8	.13	1	1/4 x 1/8	.13	9.6
0328-0460	RH	1	1/4 x 1/8	.13	1-1/4	1/4 x 1/8	.13	9.1
0329-0460	LH	1	1/4 x 1/8	.13	1-1/4	1/4 x 1/8	.13	9.1
0330-0460	RH	1-1/4	1/4 x 1/8	.13	1-1/4	1/4 x 1/8	.13	8.7
0331-0460	LH	1-1/4	1/4 x 1/8	.13	1-1/4	1/4 x 1/8	.13	8.7

## STANDARD SIZE – 2:1 RATIO – U.S.

### AVAILABLE STYLES

2:1 US STANDARD



### DIMENSIONS

Model Builder 3D CAD Available at: [www.tolomatic.com](http://www.tolomatic.com)

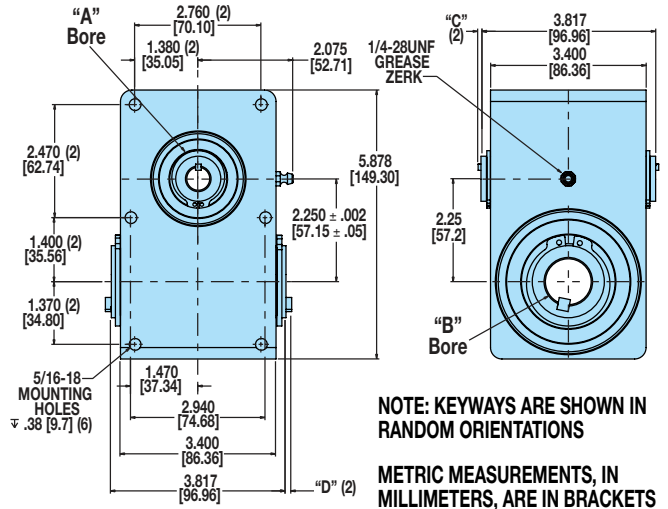

### PERFORMANCE DATA

#### High Torque Ball Bearings

#### Torque and Efficiency vs RPM at Maximum Operating Temperature

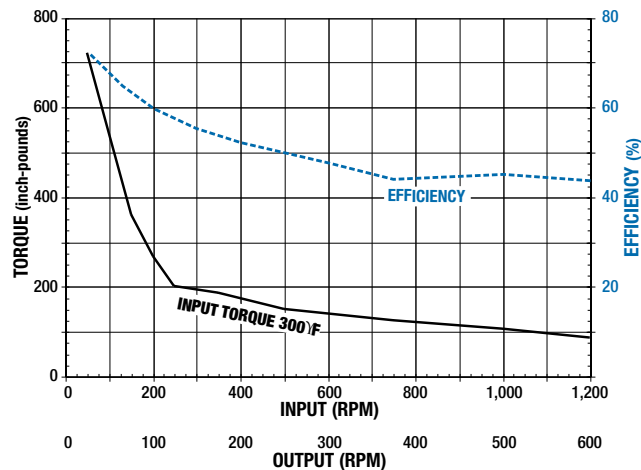

#### Models and Bore Dimensions

#### STANDARD SIZE – 2:1 RATIO – U.S. HIGH TORQUE BALL BEARING

MODEL NUMBER	RH or LH	"A" BORE			"B" BORE			APPROX. WEIGHT (LBS.)
		BORE SIZE (IN.)	WxD (IN.)	"C" DIM. (IN.)	BORE SIZE (IN.)	WxD (IN.)	"D" DIM. (IN.)	
0220-0460	RH	1/2	1/8 x 1/16	.07	3/4	3/16 x 3/32	.10	10.7
0221-0460	LH	1/2	1/8 x 1/16	.07	3/4	3/16 x 3/32	.10	10.7
0222-0460	RH	1/2	1/8 x 1/16	.07	1	1/4 x 1/8	.13	10.4
0223-0460	LH	1/2	1/8 x 1/16	.07	1	1/4 x 1/8	.13	10.4
0224-0460	RH	1/2	1/8 x 1/16	.07	1-1/4	1/4 x 1/8	.13	9.9
0225-0460	LH	1/2	1/8 x 1/16	.07	1-1/4	1/4 x 1/8	.13	9.9
0226-0460	RH	5/8	1/8 x 1/16	.07	3/4	3/16 x 3/32	.10	10.0
0227-0460	LH	5/8	1/8 x 1/16	.07	3/4	3/16 x 3/32	.10	10.0
0228-0460	RH	5/8	1/8 x 1/16	.07	1	1/4 x 1/8	.13	9.6
0229-0460	LH	5/8	1/8 x 1/16	.07	1	1/4 x 1/8	.13	9.6
0230-0460	RH	5/8	1/8 x 1/16	.07	1-1/4	1/4 x 1/8	.13	9.1
0231-0460	LH	5/8	1/8 x 1/16	.07	1-1/4	1/4 x 1/8	.13	9.1
0232-0460	RH	3/4	3/16 x 3/32	.10	3/4	3/16 x 3/32	.10	10.0
0233-0460	LH	3/4	3/16 x 3/32	.10	3/4	3/16 x 3/32	.10	10.0
0234-0460	RH	3/4	3/16 x 3/32	.10	1	1/4 x 1/8	.13	9.6
0235-0460	LH	3/4	3/16 x 3/32	.10	1	1/4 x 1/8	.13	9.6
0236-0460	RH	3/4	3/16 x 3/32	.10	1-1/4	1/4 x 1/8	.13	9.1
0237-0460	LH	3/4	3/16 x 3/32	.10	1-1/4	1/4 x 1/8	.13	9.1

SLIDE-RITE GEARBOX

ENDURANCE TECHNOLOGY

APPLICATION EXAMPLE

COMPACT SERIES 1:1 RATIO

STANDARD SERIES 1:1 RATIO

STANDARD SERIES 3:2 RATIO

STANDARD SERIES 2:1 RATIO

FLOAT-A-SHAFT

APPLICATIONS

INTRODUCTION

COMPACT SERIES 1:1 RATIO

STANDARD SERIES 1:1 RATIO

STANDARD SERIES 3:2 RATIO

STANDARD SERIES 2:1 RATIO

STANDARD SERIES 2.5:1 RATIO

SELECTION

INSTALLATION

SHAFT & KEYWAY REQUIREMENTS

## APPLICATIONS

### YOU CAN'T FIND A MORE FLEXIBLE GEAR DRIVE

If the distances between take-ups are varied during operation, both shafts can be slid axially through the Float-A-Shaft. They're available in right or left hand drives to meet your exact requirements. And what's more, the shaft's direction is reversible to suit your changing operation.

### FLOAT-A-SHAFT IS EASILY INSTALLED

An ingenious installation technique and one piece assembly eliminates coupling and shaft alignment problems.

Tolomatic makes the best right angle gear drives you can buy. We're out to prove that no one can get you around a corner faster than Tolomatic.

*NOTE: Pillow block bearing supports are recommended on all Float-A-Shaft applications. Effectively mounted directly between the Float-A-Shaft unit and the load, the pillow block bearing supports will absorb any shaft deflection or sideloading and assure alignment.*

*NOTE: All Float-A-Shaft units have 3° to 5° of backlash on reversal of input.*

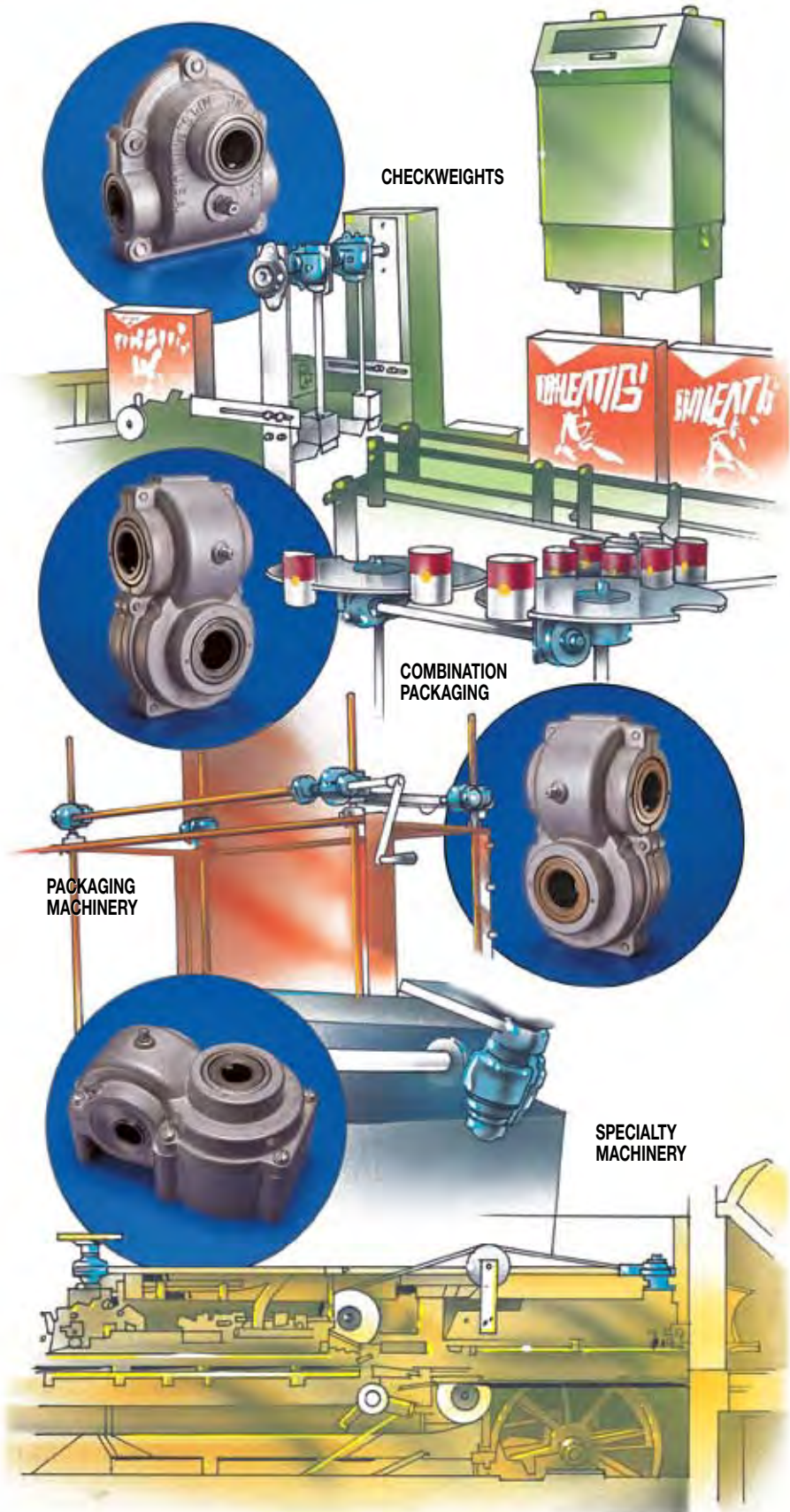

## INTRODUCTION

### TOLOMATIC IS TURNING THINGS AROUND

Tolomatic's Float-A-Shaft right angle gear drive was invented 50 years ago, and the competition still hasn't caught up. That's because Tolomatic gearboxes "float" on rotating shafts. Along with the Slide-Rite gearbox, no other design has the versatility, durability, safety, or the ease of operation as Float-A-Shaft.

Float-A-Shaft is a universal right angle gear drive coupling. It consists of two 45° helical gears that mesh at right angles, designed to turn power around any corner. Float-A-Shaft can be operated in either direction and can slide axially along the drive or driven shaft.

A lightweight aluminum housing encloses the gears, serving as a structural support and a lubricant reservoir. The gears mount directly on the shafts through keyways in the gears and shafts. These rugged and durable hardened helical gears have been field-proven for 50 years, assuring dependable operation. Yet with all of that, Float-A-Shaft retains a compact design well suited for use in tight quarters.

Float-A-Shaft's unique floating design maintains perfect alignment. It also eliminates dangerous chain sprocket drives and the additional adjustments required for chain drive applications.

### LOW TORQUE JOURNAL BEARING SERIES

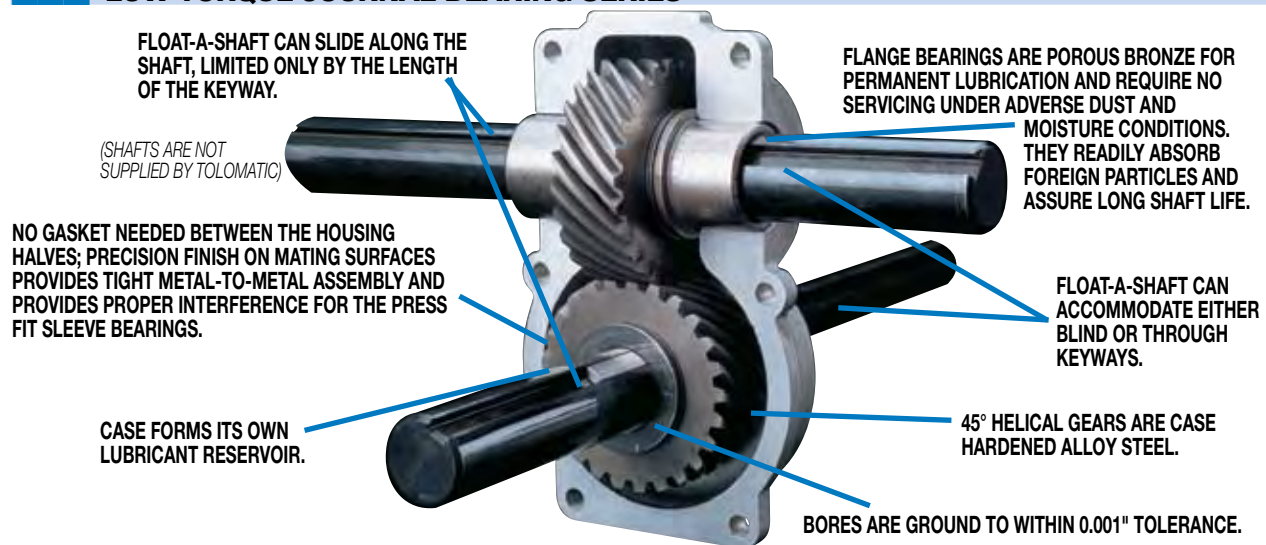

### HIGH TORQUE ROLLER BEARING SERIES

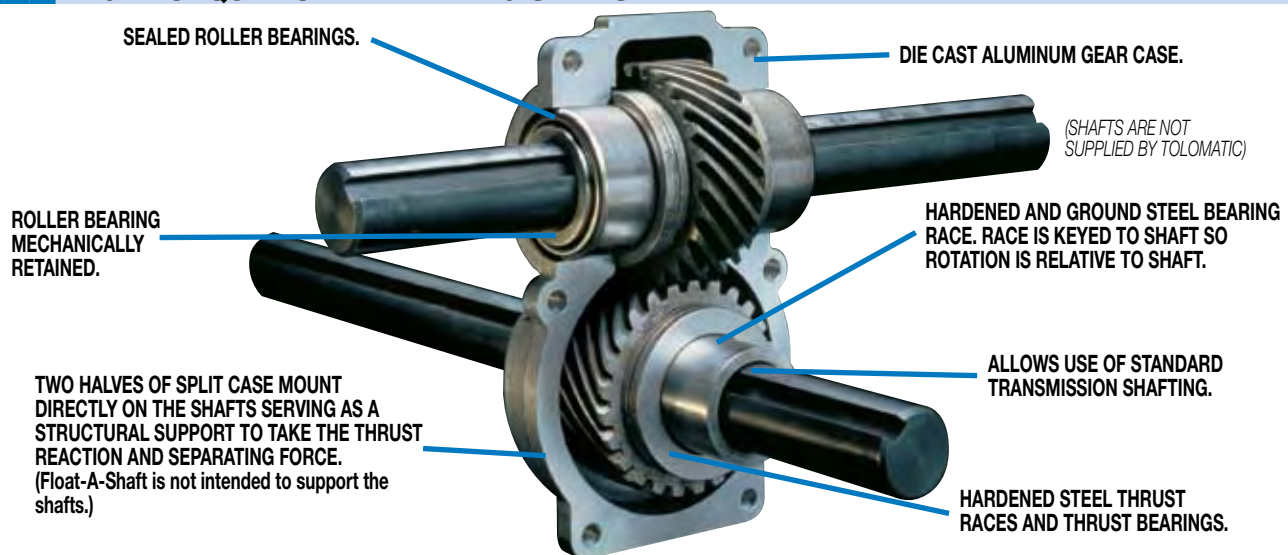

# Float-A-Shaft Gearbox

## COMPACT SERIES - 1:1 RATIO - US & METRIC

### AVAILABLE STYLES

#### Low Torque Journal Bearings

##### Standard

1-1/2 lbs. (0.68 kgs.)



##### Foot Mount

1-3/4 lbs. (0.79 kgs.)



### AVAILABLE STYLES

#### High Torque Roller Bearings

##### Standard

1-1/2 lbs. (0.68 kgs.)



##### Foot Mount

1-3/4 lbs. (0.79 kgs.)



### PERFORMANCE DATA

#### Low Torque Journal Bearings

**Torque and Efficiency vs RPM at Maximum Bearing Temperature**

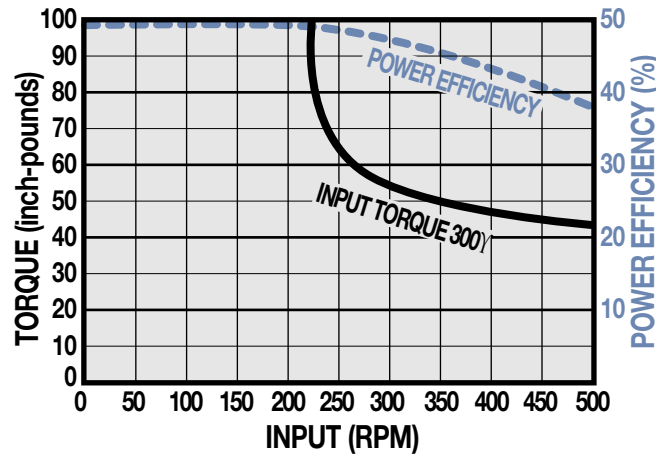

### PERFORMANCE DATA

#### High Torque Roller Bearings

**Torque and Efficiency vs RPM at Maximum Bearing Temperature**

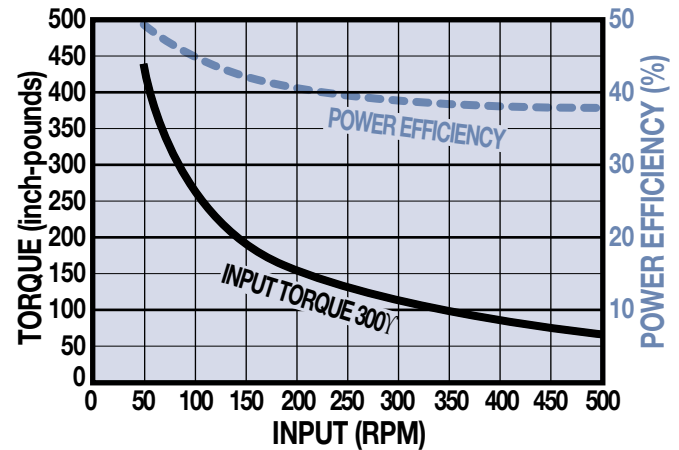

## COMPACT SERIES - 1:1 RATIO - US & METRIC

### DIMENSIONS: COMPACT STANDARD HIGH TORQUE & LOW TORQUE BEARINGS

Model Builder 3D CAD Available at: [www.tolomatic.com](http://www.tolomatic.com)

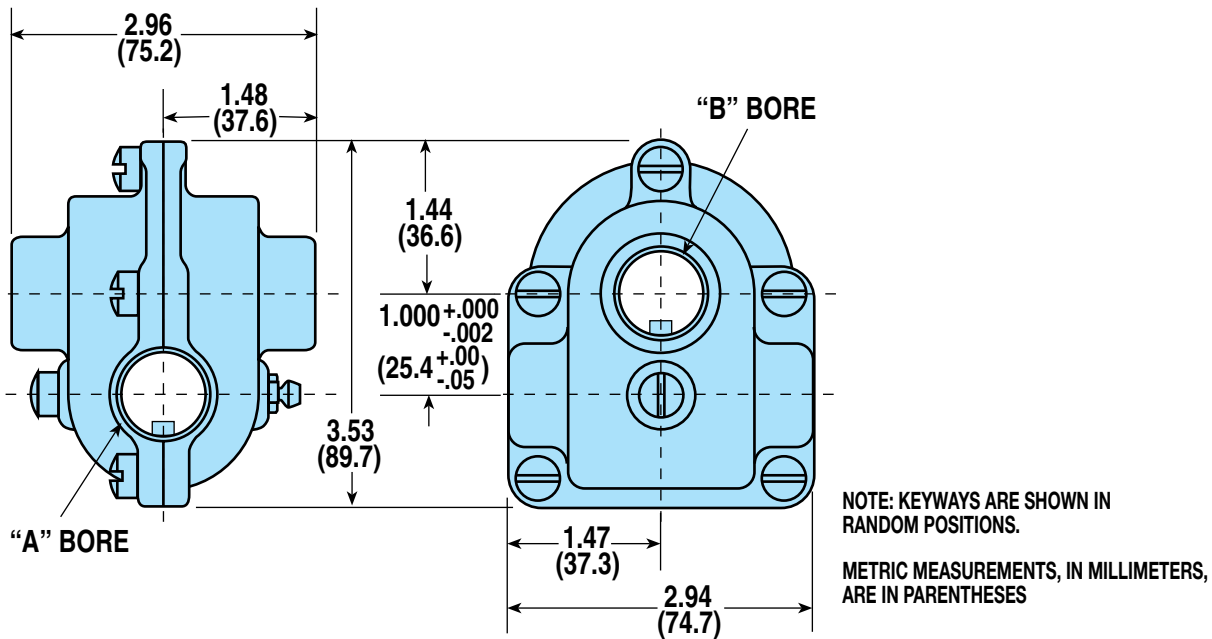

### Models and Bore Dimensions

#### U.S. - COMPACT STANDARD - 1:1

LOW TORQUE JOURNAL BEARING & HIGH TORQUE ROLLER BEARING

LOW TORQUE JOURNAL MODEL NO.	HIGH TORQUE ROLLER MODEL NO.	RH OR LH	"A" BORE		"B" BORE	
			BORE SIZE (IN.)	WxD KEYWAY (IN.)	BORE SIZE (IN.)	WxD KEYWAY (IN.)
0106-0000	0105-0100	RH	1/2	1/8 x 1/16	1/2	1/8 x 1/16
0105-0000	0106-0100	LH	1/2	1/8 x 1/16	1/2	1/8 x 1/16
0108-0000	0107-0100	RH	1/2	1/8 x 1/16	5/8	1/8 x 1/16
0107-0000	0108-0100	LH	1/2	1/8 x 1/16	5/8	1/8 x 1/16
0110-0000	0109-0100	RH	5/8	1/8 x 1/16	5/8	1/8 x 1/16
0109-0000	0110-0100	LH	5/8	1/8 x 1/16	5/8	1/8 x 1/16

#### METRIC - COMPACT STANDARD - 1:1

HIGH TORQUE ROLLER BEARING

HIGH TORQUE ROLLER MODEL NO.	RH OR LH	"A" BORE		"B" BORE	
		BORE SIZE (MM)	WxD KEYWAY (MM)	BORE SIZE (MM)	WxD KEYWAY (MM)
0120-0100	RH	12	4 x 2	12	4 x 2
0121-0100	LH	12	4 x 2	12	4 x 2
0122-0100	RH	12	4 x 2	15	5 x 2.5
0123-0100	LH	12	4 x 2	15	5 x 2.5
0124-0100	RH	15	5 x 2.5	15	5 x 2.5
0125-0100	LH	15	5 x 2.5	15	5 x 2.5

NOTE: METRIC SIZES AVAILABLE ONLY IN HIGH TORQUE ROLLER BEARING MODELS.

## COMPACT SERIES - 1:1 RATIO - US & METRIC

- SLIDE-RITE GEARBOX
- ENDURANCE TECHNOLOGY
- APPLICATION EXAMPLE
- COMPACT SERIES 1:1 RATIO
- STANDARD SERIES 1:1 RATIO
- STANDARD SERIES 3:2 RATIO
- STANDARD SERIES 2:1 RATIO
- FLOAT-A-SHAFT
- APPLICATIONS INTRODUCTION
- COMPACT SERIES 1:1 RATIO
- STANDARD SERIES 1:1 RATIO
- STANDARD SERIES 3:2 RATIO
- STANDARD SERIES 2:1 RATIO
- STANDARD SERIES 2.5:1 RATIO
- SELECTION
- INSTALLATION
- SHAFT & KEYWAY REQUIREMENTS

### DIMENSIONS: COMPACT FOOT MOUNT HIGH TORQUE & LOW TORQUE BEARINGS

Model Builder 3D CAD Available at: [www.tolomatic.com](http://www.tolomatic.com)

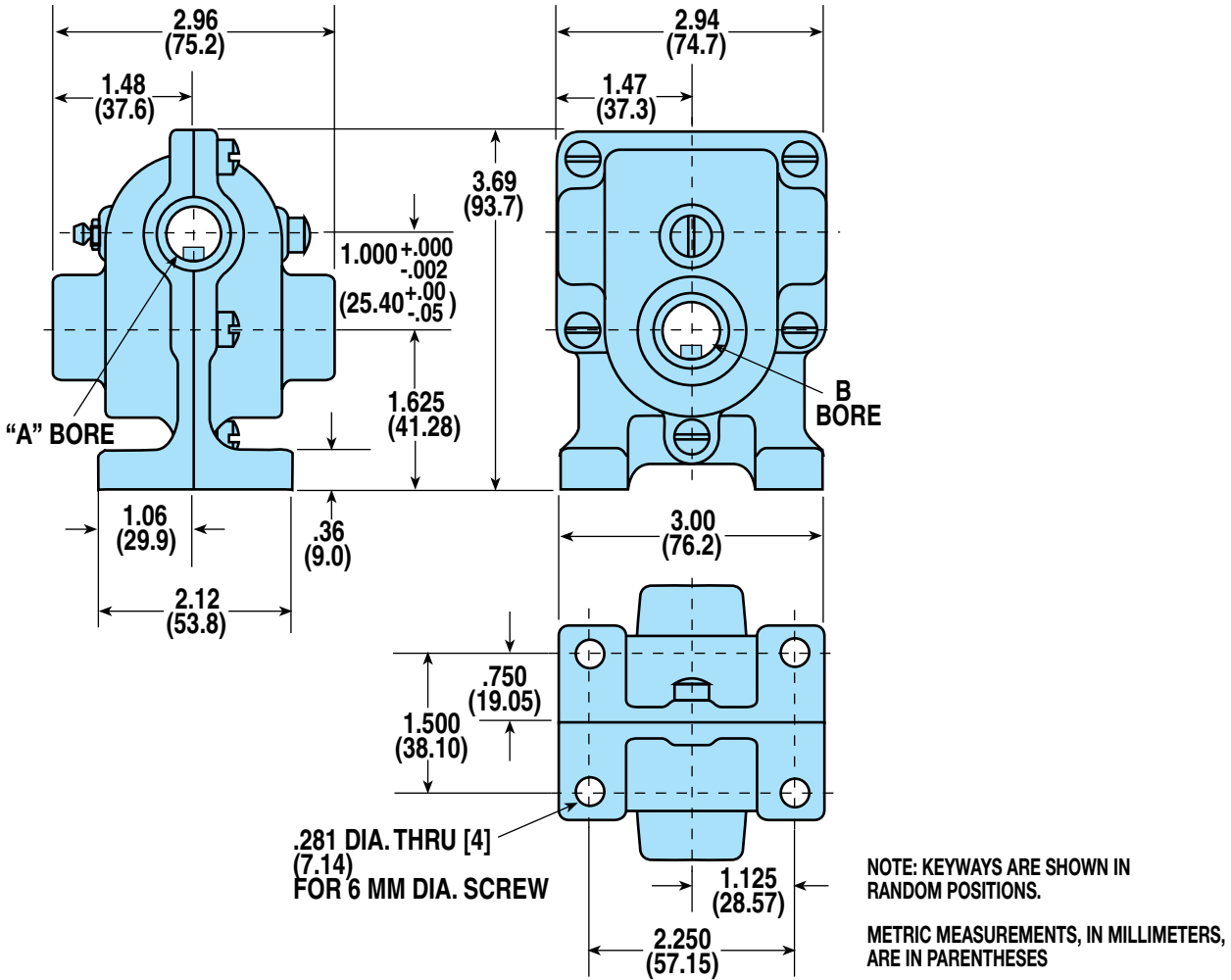

### Models and Bore Dimensions

#### U.S. - COMPACT FOOT MOUNT - 1:1

LOW TORQUE JOURNAL BEARING & HIGH TORQUE ROLLER BEARING

LOW TORQUE JOURNAL MODEL NO.	HIGH TORQUE ROLLER MODEL NO.	RH OR LH	"A" BORE		"B" BORE	
			BORE SIZE (IN.)	WxD KEYWAY (IN.)	BORE SIZE (IN.)	WxD KEYWAY (IN.)
0112-0000	0111-0100	RH	1/2	1/8 x 1/16	1/2	1/8 x 1/16
0111-0000	0112-0100	LH	1/2	1/8 x 1/16	1/2	1/8 x 1/16
0114-0000	0113-0100	RH	1/2	1/8 x 1/16	5/8	1/8 x 1/16
0113-0000	0114-0100	LH	1/2	1/8 x 1/16	5/8	1/8 x 1/16
0116-0000	0115-0100	RH	5/8	1/8 x 1/16	5/8	1/8 x 1/16
0115-0000	0116-0100	LH	5/8	1/8 x 1/16	5/8	1/8 x 1/16

#### METRIC - COMPACT FOOT MOUNT - 1:1 HIGH TORQUE ROLLER BEARING

HIGH TORQUE ROLLER MODEL NO.	RH OR LH	"A" BORE		"B" BORE	
		BORE SIZE (MM)	WxD KEYWAY (MM)	BORE SIZE (MM)	WxD KEYWAY (MM)
0126-0100	RH	12	4 x 2	12	4 x 2
0127-0100	LH	12	4 x 2	12	4 x 2
0128-0100	RH	12	4 x 2	15	5 x 2.5
0129-0100	LH	12	4 x 2	15	5 x 2.5
0130-0100	RH	15	5 x 2.5	15	5 x 2.5
0131-0100	LH	15	5 x 2.5	15	5 x 2.5

NOTE: METRIC SIZES AVAILABLE ONLY IN HIGH TORQUE ROLLER BEARING MODELS.

## STANDARD SERIES - 1:1 RATIO - US & METRIC

### AVAILABLE STYLES

#### Low Torque Journal Bearings

##### Standard

5 lbs. (2.27 kgs.)



##### Flat Base

5-3/4 lbs. (2.61 kgs.)



### AVAILABLE STYLES

#### High Torque Roller Bearings

##### Standard

5-1/2 lbs. (2.49 kgs.)



##### Flat Base

6-1/2 lbs. (2.95 kgs.)



### PERFORMANCE DATA

#### Low Torque Journal Bearings

**Torque and Efficiency vs RPM at Maximum Bearing Temperature**

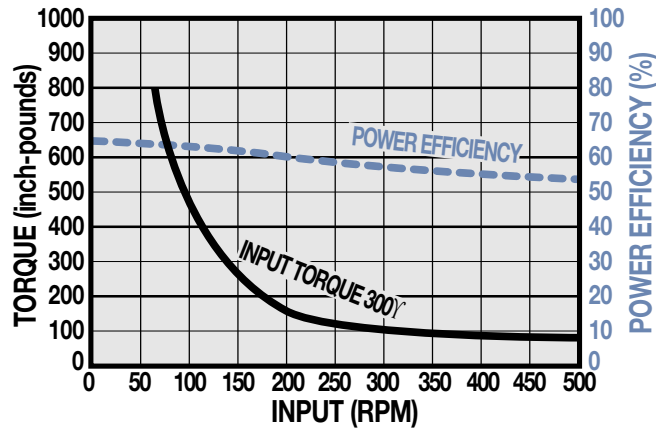

### PERFORMANCE DATA

#### High Torque Roller Bearings

**Torque and Efficiency vs RPM at Maximum Bearing Temperature**

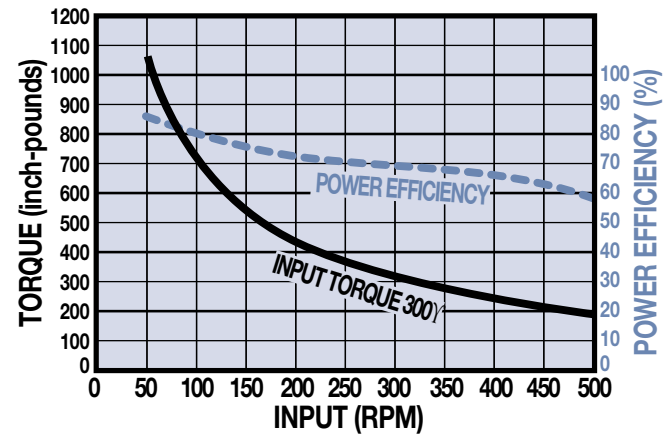

## STANDARD SERIES - 1:1 RATIO - US & METRIC

### DIMENSIONS: STANDARD HIGH TORQUE & LOW TORQUE BEARINGS

Model Builder 3D CAD Available at: [www.tolomatic.com](http://www.tolomatic.com)

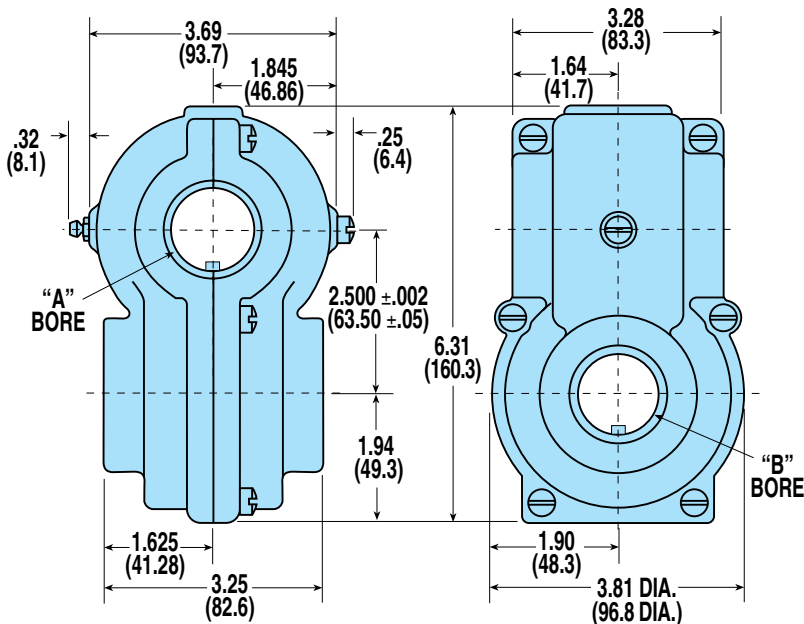

NOTE: KEYWAYS ARE SHOWN IN RANDOM POSITIONS.

METRIC MEASUREMENTS, IN MILLIMETERS, ARE IN PARENTHESES

### Models and Bore Dimensions

#### U.S. - STANDARD - 1:1

##### LOW TORQUE JOURNAL BEARING & HIGH TORQUE ROLLER BEARING

LOW TORQUE JOURNAL MODEL NO.	HIGH TORQUE ROLLER MODEL NO.	RH OR LH	"A" BORE		"B" BORE	
			BORE SIZE (IN.)	WxD KEYWAY (IN.)	BORE SIZE (IN.)	WxD KEYWAY (IN.)
0204-0000	0203-0200	RH	3/4	3/16 x 3/32	3/4	3/16 x 3/32
0203-0000	0204-0200	LH	3/4	3/16 x 3/32	3/4	3/16 x 3/32
0208-0000	0205-0200	RH	3/4	3/16 x 3/32	1	1/4 x 1/8
0207-0000	0206-0200	LH	3/4	3/16 x 3/32	1	1/4 x 1/8
0212-0000	0207-0200	RH	3/4	3/16 x 3/32	1-1/4	1/4 x 1/8
0211-0000	0208-0200	LH	3/4	3/16 x 3/32	1-1/4	1/4 x 1/8
0216-0000	NA	RH	3/4	3/16 x 3/32	1-1/2	3/8 x 3/16
0215-0000	NA	LH	3/4	3/16 x 3/32	1-1/2	3/8 x 3/16
0220-0000	0209-0200	RH	1	1/4 x 1/8	1	1/4 x 1/8
0219-0000	0210-0200	LH	1	1/4 x 1/8	1	1/4 x 1/8
0224-0000	0211-0200	RH	1	1/4 x 1/8	1-1/4	1/4 x 1/8
0223-0000	0212-0200	LH	1	1/4 x 1/8	1-1/4	1/4 x 1/8
0228-0000	NA	RH	1	1/4 x 1/8	1-1/2	3/8 x 3/16
0227-0000	NA	LH	1	1/4 x 1/8	1-1/2	3/8 x 3/16
0232-0000	0213-0200	RH	1-1/4	1/4 x 1/8	1-1/4	1/4 x 1/8
0231-0000	0214-0200	LH	1-1/4	1/4 x 1/8	1-1/4	1/4 x 1/8
0236-0000	NA	RH	1-1/4	1/4 x 1/8	1-1/2	3/8 x 3/16
0235-0000	NA	LH	1-1/4	1/4 x 1/8	1-1/2	3/8 x 3/16
0240-0000	NA	RH	1-1/2	3/8 x 3/16	1-1/2	3/8 x 3/16
0239-0000	NA	LH	1-1/2	3/8 x 3/16	1-1/2	3/8 x 3/16

#### METRIC - STANDARD - 1:1 HIGH TORQUE ROLLER BEARING

HIGH TORQUE ROLLER MODEL NO.	RH OR LH	"A" BORE		"B" BORE	
		BORE SIZE (MM)	WxD KEYWAY (MM)	BORE SIZE (MM)	WxD KEYWAY (MM)
0308-0200	RH	20	6 x 3	20	6 x 3
0309-0200	LH	20	6 x 3	20	6 x 3
0310-0200	RH	20	6 x 3	25	8 x 3.5
0311-0200	LH	20	6 x 3	25	8 x 3.5
0312-0200	RH	20	6 x 3	30	8 x 3.5
0313-0200	LH	20	6 x 3	30	8 x 3.5
0314-0200	RH	25	8 x 3.5	25	8 x 3.5
0315-0200	LH	25	8 x 3.5	25	8 x 3.5
0316-0200	RH	25	8 x 3.5	30	8 x 3.5
0317-0200	LH	25	8 x 3.5	30	8 x 3.5
0318-0200	RH	30	8 x 3.5	30	8 x 3.5
0319-0200	LH	30	8 x 3.5	30	8 x 3.5

NOTE: METRIC SIZES AVAILABLE ONLY IN HIGH TORQUE ROLLER BEARING MODELS.

## STANDARD SERIES - 1:1 RATIO - US & METRIC

**DIMENSIONS: STANDARD FLAT BASE HIGH TORQUE & LOW TORQUE BEARINGS**

Model Builder 3D CAD Available at: [www.tolomatic.com](http://www.tolomatic.com)

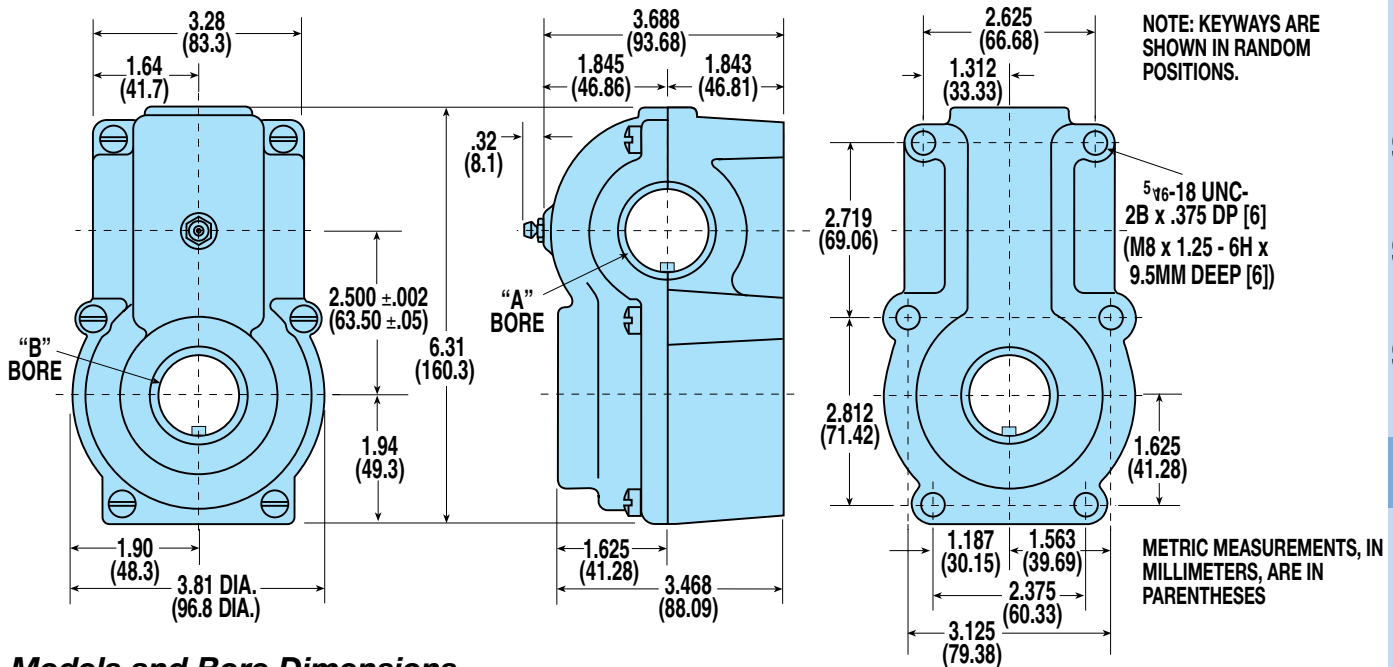

### Models and Bore Dimensions

#### U.S. - STANDARD FLAT BASE - 1:1

LOW TORQUE JOURNAL BEARING & HIGH TORQUE ROLLER BEARING

LOW TORQUE JOURNAL MODEL NO.	HIGH TORQUE ROLLER MODEL NO.	RH OR LH	"A" BORE		"B" BORE	
			BORE SIZE (IN.)	WxD KEYWAY (IN.)	BORE SIZE (IN.)	WxD KEYWAY (IN.)
0245-0000	0217-0200	RH	3/4	3/16 x 3/32	3/4	3/16 x 3/32
0246-0000	0218-0200	LH	3/4	3/16 x 3/32	3/4	3/16 x 3/32
0247-0000	0219-0200	RH	3/4	3/16 x 3/32	1	1/4 x 1/8
0248-0000	0220-0200	LH	3/4	3/16 x 3/32	1	1/4 x 1/8
0249-0000	0221-0200	RH	3/4	3/16 x 3/32	1-1/4	1/4 x 1/8
0250-0000	0222-0200	LH	3/4	3/16 x 3/32	1-1/4	1/4 x 1/8
0251-0000	NA	RH	3/4	3/16 x 3/32	1-1/2	3/8 x 3/16
0252-0000	NA	LH	3/4	3/16 x 3/32	1-1/2	3/8 x 3/16
0253-0000	0223-0200	RH	1	1/4 x 1/8	1	1/4 x 1/8
0254-0000	0224-0200	LH	1	1/4 x 1/8	1	1/4 x 1/8
0255-0000	0225-0200	RH	1	1/4 x 1/8	1-1/4	1/4 x 1/8
0256-0000	0226-0200	LH	1	1/4 x 1/8	1-1/4	1/4 x 1/8
0257-0000	NA	RH	1	1/4 x 1/8	1-1/2	3/8 x 3/16
0258-0000	NA	LH	1	1/4 x 1/8	1-1/2	3/8 x 3/16
0269-0000	0227-0200	RH	1-1/4	1/4 x 1/8	1-1/4	1/4 x 1/8
0270-0000	0228-0200	LH	1-1/4	1/4 x 1/8	1-1/4	1/4 x 1/8
0271-0000	NA	RH	1-1/4	1/4 x 1/8	1-1/2	3/8 x 3/16
0272-0000	NA	LH	1-1/4	1/4 x 1/8	1-1/2	3/8 x 3/16
0273-0000	NA	RH	1-1/2	3/8 x 3/16	1-1/2	3/8 x 3/16
0274-0000	NA	LH	1-1/2	3/8 x 3/16	1-1/2	3/8 x 3/16

#### METRIC - STANDARD FLAT BASE - 1:1 HIGH TORQUE ROLLER BEARING

HIGH TORQUE ROLLER MODEL NO.	RH OR LH	"A" BORE		"B" BORE	
		BORE SIZE (MM)	WxD KEYWAY (MM)	BORE SIZE (MM)	WxD KEYWAY (MM)
0328-0200	RH	20	6 x 3	20	6 x 3
0329-0200	LH	20	6 x 3	20	6 x 3
0330-0200	RH	20	6 x 3	25	8 x 3.5
0331-0200	LH	20	6 x 3	25	8 x 3.5
0332-0200	RH	20	6 x 3	30	8 x 3.5
0333-0200	LH	20	6 x 3	30	8 x 3.5
0334-0200	RH	25	8 x 3.5	25	8 x 3.5
0335-0200	LH	25	8 x 3.5	25	8 x 3.5
0336-0200	RH	25	8 x 3.5	30	8 x 3.5
0337-0200	LH	25	8 x 3.5	30	8 x 3.5
0338-0200	RH	30	8 x 3.5	30	8 x 3.5
0339-0200	LH	30	8 x 3.5	30	8 x 3.5

NOTE: METRIC SIZES AVAILABLE ONLY IN HIGH TORQUE ROLLER BEARING MODELS.

# Float-A-Shaft Gearbox

## STANDARD SERIES - 3:2 RATIO - US & METRIC

### AVAILABLE STYLES

#### Low Torque Journal Bearings

##### Standard

5-3/4 lbs. (2.61 kgs.)

##### Flat Base

5-3/4 lbs. (2.61 kgs.)



### AVAILABLE STYLES

#### High Torque Roller Bearings

##### Standard

6 lbs. (2.72 kgs.)

##### Flat Base

6-3/4 lbs. (3.06 kgs.)



### PERFORMANCE DATA

#### Low Torque Journal Bearings

**Torque and Efficiency vs RPM at Maximum Bearing Temperature**

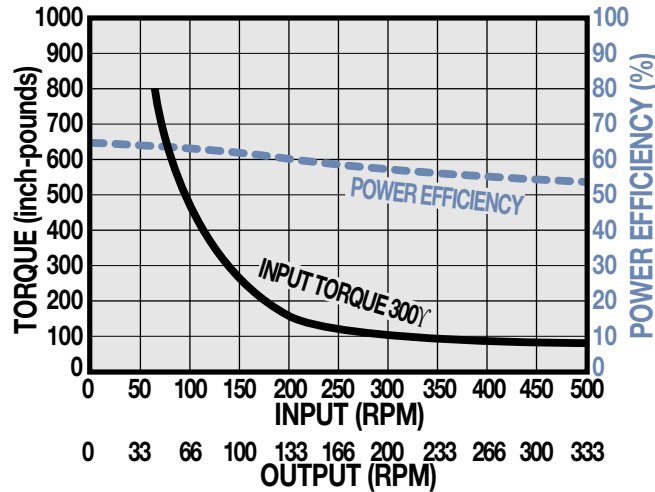

### PERFORMANCE DATA

#### High Torque Roller Bearings

**Torque and Efficiency vs RPM at Maximum Bearing Temperature**

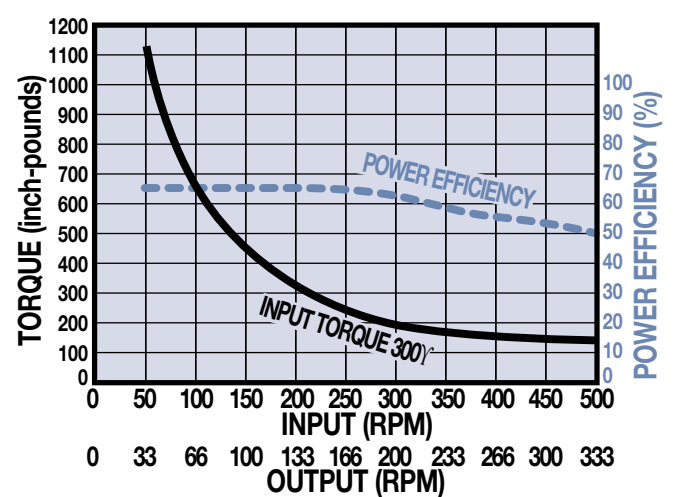

## STANDARD SERIES - 3:2 RATIO - US & METRIC

### DIMENSIONS: STANDARD HIGH TORQUE & LOW TORQUE BEARINGS

Model Builder 3D CAD Available at: [www.tolomatic.com](http://www.tolomatic.com)

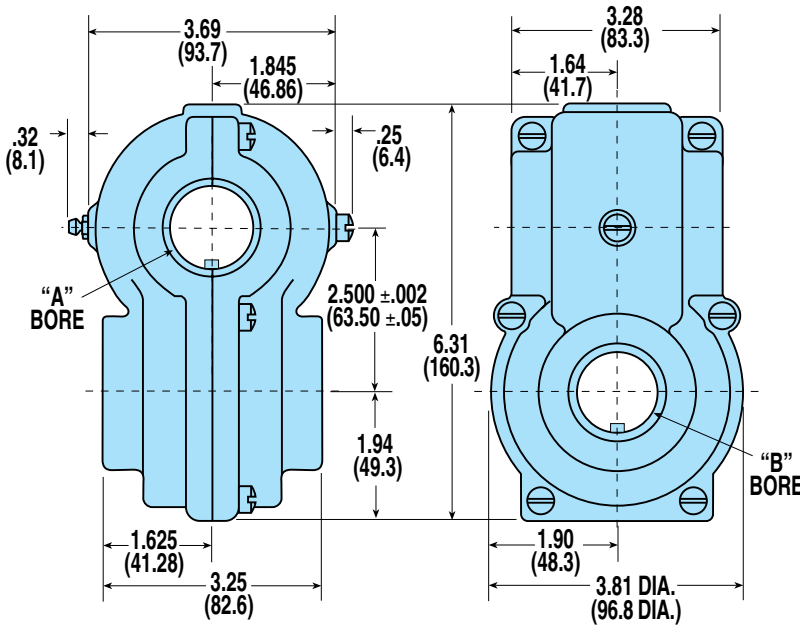

NOTE: KEYWAYS ARE SHOWN IN RANDOM POSITIONS.

METRIC MEASUREMENTS, IN MILLIMETERS, ARE IN PARENTHESES

### Models and Bore Dimensions

#### U.S. - STANDARD - 3:2

##### LOW TORQUE JOURNAL BEARING & HIGH TORQUE ROLLER BEARING

LOW TORQUE JOURNAL MODEL NO.	HIGH TORQUE ROLLER MODEL NO.	RH OR LH	"A" BORE		"B" BORE	
			BORE SIZE (IN.)	WxD KEYWAY (IN.)	BORE SIZE (IN.)	WxD KEYWAY (IN.)
0241-0000	0231-0200	RH	3/4	3/16 x 3/32	3/4	3/16 x 3/32
0242-0000	0232-0200	LH	3/4	3/16 x 3/32	3/4	3/16 x 3/32
0259-0000	0233-0200	RH	3/4	3/16 x 3/32	1	1/4 x 1/8
0260-0000	0234-0200	LH	3/4	3/16 x 3/32	1	1/4 x 1/8
NA	0235-0200	RH	3/4	3/16 x 3/32	1-1/4	1/4 x 1/8
NA	0236-0200	LH	3/4	3/16 x 3/32	1-1/4	1/4 x 1/8
0261-0000	0237-0200	RH	1	1/4 x 1/8	1	1/4 x 1/8
0262-0000	0238-0200	LH	1	1/4 x 1/8	1	1/4 x 1/8
0263-0000	0239-0200	RH	1	1/4 x 1/8	1-1/4	1/4 x 1/8
0264-0000	0240-0200	LH	1	1/4 x 1/8	1-1/4	1/4 x 1/8
0265-0000	0241-0200	RH	1-1/4	1/4 x 1/8	1-1/4	1/4 x 1/8
0266-0000	0242-0200	LH	1-1/4	1/4 x 1/8	1-1/4	1/4 x 1/8

NOTE: FOR LOW TORQUE JOURNAL BEARING MODELS  
THE "A" BORE CONTAINS THE 20 TOOTH GEAR. THE "B" BORE CONTAINS THE 30 TOOTH GEAR.

NOTE: FOR HIGH TORQUE ROLLER BEARING MODELS  
THE "A" BORE CONTAINS THE 20 TOOTH GEAR. THE "B" BORE CONTAINS THE 30 TOOTH GEAR.

#### METRIC - STANDARD - 3:2 HIGH TORQUE ROLLER BEARING

HIGH TORQUE ROLLER MODEL NO.	RH OR LH	"A" BORE		"B" BORE	
		BORE SIZE (MM)	WxD KEYWAY (MM)	BORE SIZE (MM)	WxD KEYWAY (MM)
0354-0200	RH	25	8 x 3.5	25	8 x 3.5
0355-0200	LH	25	8 x 3.5	25	8 x 3.5
0356-0200	RH	25	8 x 3.5	30	8 x 3.5
0357-0200	LH	25	8 x 3.5	30	8 x 3.5
0358-0200	RH	30	8 x 3.5	30	8 x 3.5
0359-0200	LH	30	8 x 3.5	30	8 x 3.5

NOTE: METRIC SIZES AVAILABLE ONLY IN HIGH TORQUE ROLLER BEARING MODELS.

## STANDARD SERIES - 3:2 RATIO - US & METRIC

### DIMENSIONS: STANDARD FLAT BASE HIGH TORQUE & LOW TORQUE BEARINGS

Model Builder 3D CAD Available at: [www.tolomatic.com](http://www.tolomatic.com)

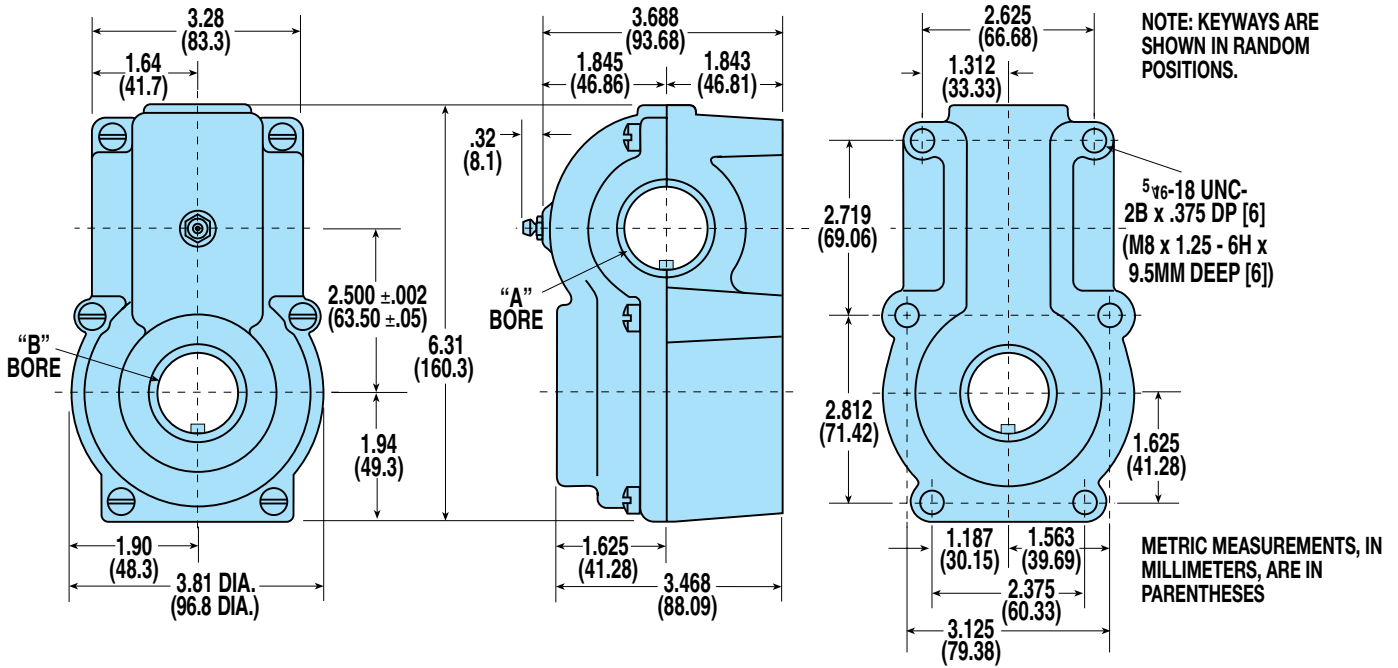

### Models and Bore Dimensions

#### U.S. - STANDARD FLAT BASE - 3:2

##### LOW TORQUE JOURNAL BEARING & HIGH TORQUE ROLLER BEARING

LOW TORQUE JOURNAL MODEL NO.	HIGH TORQUE ROLLER MODEL NO.	RH OR LH	"A" BORE		"B" BORE	
			BORE SIZE (IN.)	WXD KEYWAY (IN.)	BORE SIZE (IN.)	WXD KEYWAY (IN.)
0277-0000	0245-0200	RH	3/4	3/16 x 3/32	3/4	3/16 x 3/32
0278-0000	0246-0200	LH	3/4	3/16 x 3/32	3/4	3/16 x 3/32
0279-0000	0247-0200	RH	3/4	3/16 x 3/32	1	1/4 x 1/8
0280-0000	0248-0200	LH	3/4	3/16 x 3/32	1	1/4 x 1/8
NA	0249-0200	RH	3/4	3/16 x 3/32	1-1/4	1/4 x 1/8
NA	0250-0200	LH	3/4	3/16 x 3/32	1-1/4	1/4 x 1/8
0281-0000	0251-0200	RH	1	1/4 x 1/8	1	1/4 x 1/8
0282-0000	0252-0200	LH	1	1/4 x 1/8	1	1/4 x 1/8
0283-0000	0253-0200	RH	1	1/4 x 1/8	1-1/4	1/4 x 1/8
0284-0000	0254-0200	LH	1	1/4 x 1/8	1-1/4	1/4 x 1/8
0285-0000	0255-0200	RH	1-1/4	1/4 x 1/8	1-1/4	1/4 x 1/8
0286-0000	0256-0200	LH	1-1/4	1/4 x 1/8	1-1/4	1/4 x 1/8

#### METRIC - STANDARD FLAT BASE - 3:2 HIGH TORQUE ROLLER BEARING

HIGH TORQUE ROLLER MODEL NO.	RH OR LH	"A" BORE		"B" BORE	
		BORE SIZE (MM)	WXD KEYWAY (MM)	BORE SIZE (MM)	WXD KEYWAY (MM)
0374-0200	RH	25	8 x 3.5	25	8 x 3.5
0375-0200	LH	25	8 x 3.5	25	8 x 3.5
0376-0200	RH	25	8 x 3.5	30	8 x 3.5
0377-0200	LH	25	8 x 3.5	30	8 x 3.5
0378-0200	RH	30	8 x 3.5	30	8 x 3.5
0379-0200	LH	30	8 x 3.5	30	8 x 3.5

NOTE: FOR LOW TORQUE JOURNAL BEARING MODELS  
THE "A" BORE CONTAINS THE 20 TOOTH GEAR. THE "B" BORE CONTAINS THE 30 TOOTH GEAR.

NOTE: FOR HIGH TORQUE ROLLER BEARING MODELS  
THE "A" BORE CONTAINS THE 20 TOOTH GEAR. THE "B" BORE CONTAINS THE 30 TOOTH GEAR.

## STANDARD SERIES - 2:1 RATIO - US & METRIC

### AVAILABLE STYLES

#### Low Torque Journal Bearings

##### Standard

3-1/2 lbs. (1.59 kgs.)



### AVAILABLE STYLES

#### High Torque Roller Bearings

##### Standard

6-1/4 lbs. (2.84 kgs.)



##### Flat Base

6-3/4 lbs. (3.06 kgs.)



### PERFORMANCE DATA

#### Low Torque Journal Bearings

**Torque and Efficiency vs RPM at Maximum Bearing Temperature**

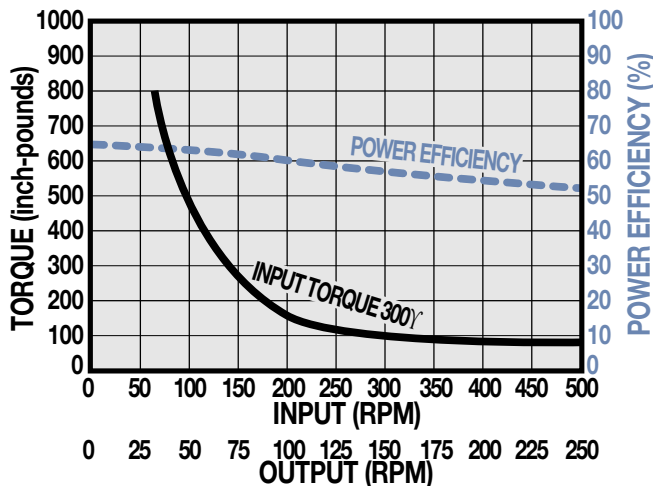

### PERFORMANCE DATA

#### High Torque Roller Bearings

**Torque and Efficiency vs RPM at Maximum Bearing Temperature**

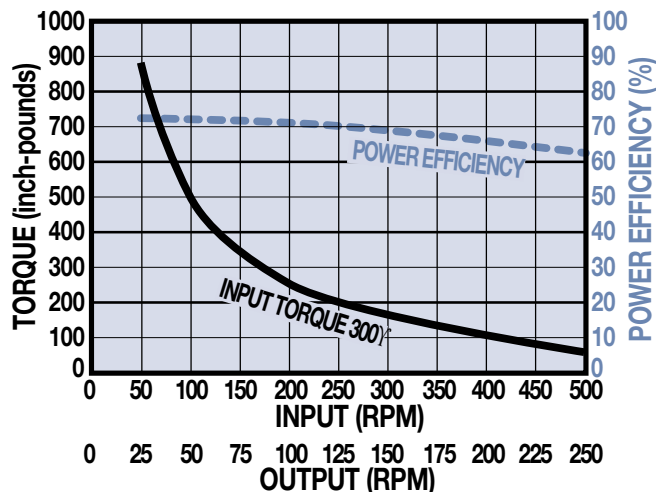

# Float-A-Shaft Gearbox

## STANDARD SERIES - 2:1 RATIO - US & METRIC

SLIDE-RITE GEARBOX

ENDURANCE TECHNOLOGY

APPLICATION EXAMPLE

COMPACT SERIES 1:1 RATIO

STANDARD SERIES 1:1 RATIO

STANDARD SERIES 3:2 RATIO

STANDARD SERIES 2:1 RATIO

FLOAT-A-SHAFT

APPLICATIONS INTRODUCTION

COMPACT SERIES 1:1 RATIO

STANDARD SERIES 1:1 RATIO

STANDARD SERIES 3:2 RATIO

STANDARD SERIES 2:1 RATIO

STANDARD SERIES 2.5:1 RATIO

SELECTION

INSTALLATION

SHAFT & KEYWAY REQUIREMENTS

### DIMENSIONS: STANDARD LOW TORQUE BEARINGS

Model Builder 3D CAD Available at: [www.tolomatic.com](http://www.tolomatic.com)

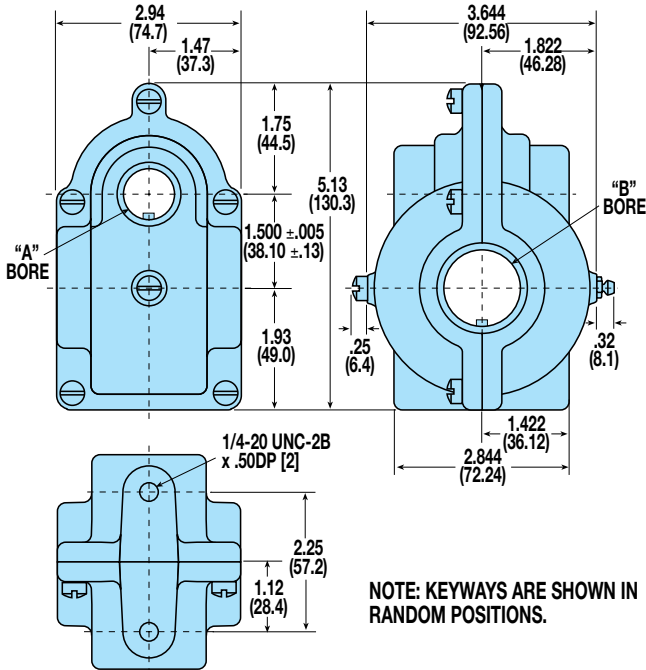

### DIMENSIONS: STANDARD HIGH TORQUE BEARINGS

Model Builder 3D CAD Available at: [www.tolomatic.com](http://www.tolomatic.com)

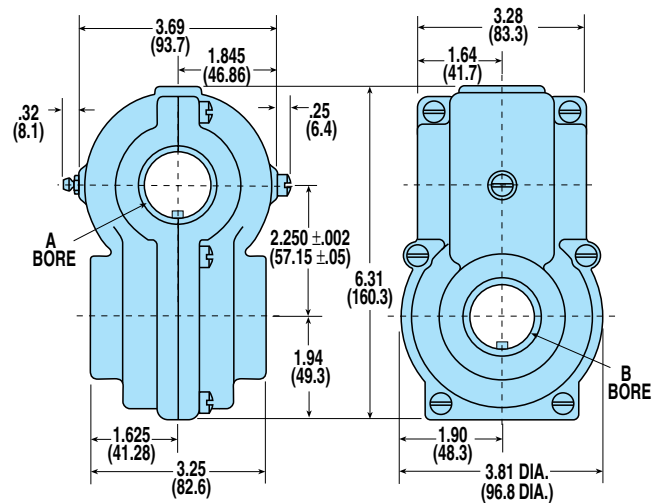

### Models and Bore Dimensions

#### U.S. - STANDARD - 2:1

#### LOW TORQUE JOURNAL BEARING & HIGH TORQUE ROLLER BEARING

LOW TORQUE JOURNAL MODEL NO.	HIGH TORQUE ROLLER MODEL NO.	RH OR LH	"A" BORE		"B" BORE	
			BORE SIZE (IN.)	WxD KEYWAY (IN.)	BORE SIZE (IN.)	WxD KEYWAY (IN.)
0304-0000	0259-0200	RH	1/2	1/8 x 1/16	3/4	3/16 x 3/32
0303-0000	0260-0200	LH	1/2	1/8 x 1/16	3/4	3/16 x 3/32
0308-0000	0261-0200	RH	1/2	1/8 x 1/16	1	1/4 x 1/8
0307-0000	0262-0200	LH	1/2	1/8 x 1/16	1	1/4 x 1/8
0312-0000	0263-0200	RH	1/2	1/8 x 1/16	1-1/4	1/4 x 1/8
0311-0000	0264-0200	LH	1/2	1/8 x 1/16	1-1/4	1/4 x 1/8
0318-0000	0265-0200	RH	5/8	1/8 x 1/16	3/4	3/16 x 3/32
0317-0000	0266-0200	LH	5/8	1/8 x 1/16	3/4	3/16 x 3/32
0322-0000	0267-0200	RH	5/8	1/8 x 1/16	1	1/4 x 1/8
0321-0000	0268-0200	LH	5/8	1/8 x 1/16	1	1/4 x 1/8
0326-0000	0269-0200	RH	5/8	1/8 x 1/16	1-1/4	1/4 x 1/8
0325-0000	0270-0200	LH	5/8	1/8 x 1/16	1-1/4	1/4 x 1/8
NA	0271-0200	RH	3/4	3/16 x 3/32	3/4	3/16 x 3/32
NA	0272-0200	LH	3/4	3/16 x 3/32	3/4	3/16 x 3/32
NA	0273-0200	RH	3/4	3/16 x 3/32	1	1/4 x 1/8
NA	0274-0200	LH	3/4	3/16 x 3/32	1	1/4 x 1/8
NA	0275-0200	RH	3/4	3/16 x 3/32	1-1/4	1/4 x 1/8
NA	0276-0200	LH	3/4	3/16 x 3/32	1-1/4	1/4 x 1/8

NOTE: FOR LOW TORQUE JOURNAL BEARING MODELS: THE "A" BORE CONTAINS THE 10 TOOTH GEAR. THE "B" BORE CONTAINS THE 20 TOOTH GEAR.

#### METRIC - STANDARD - 2:1 HIGH TORQUE ROLLER BEARING

HIGH TORQUE ROLLER MODEL NO.	RH OR LH	"A" BORE		"B" BORE	
		BORE SIZE (MM)	WxD KEYWAY (MM)	BORE SIZE (MM)	WxD KEYWAY (MM)
0390-0200	RH	15	5 x 2.5	20	6 x 3
0391-0200	LH	15	5 x 2.5	20	6 x 3
0392-0200	RH	15	5 x 2.5	25	8 x 3.5
0393-0200	LH	15	5 x 2.5	25	8 x 3.5
0394-0200	RH	15	5 x 2.5	30	8 x 3.5
0395-0200	LH	15	5 x 2.5	30	8 x 3.5

NOTE: METRIC SIZES AVAILABLE ONLY IN HIGH TORQUE ROLLER BEARING MODELS.

NOTE: FOR HIGH TORQUE ROLLER BEARING MODELS: THE "A" BORE CONTAINS THE 15 TOOTH GEAR. THE "B" BORE CONTAINS THE 30 TOOTH GEAR.

## STANDARD SERIES - 2:1 RATIO - US & METRIC

### DIMENSIONS: STANDARD FLAT BASE HIGH TORQUE BEARINGS

Model Builder 3D CAD Available at: [www.tolomatic.com](http://www.tolomatic.com)

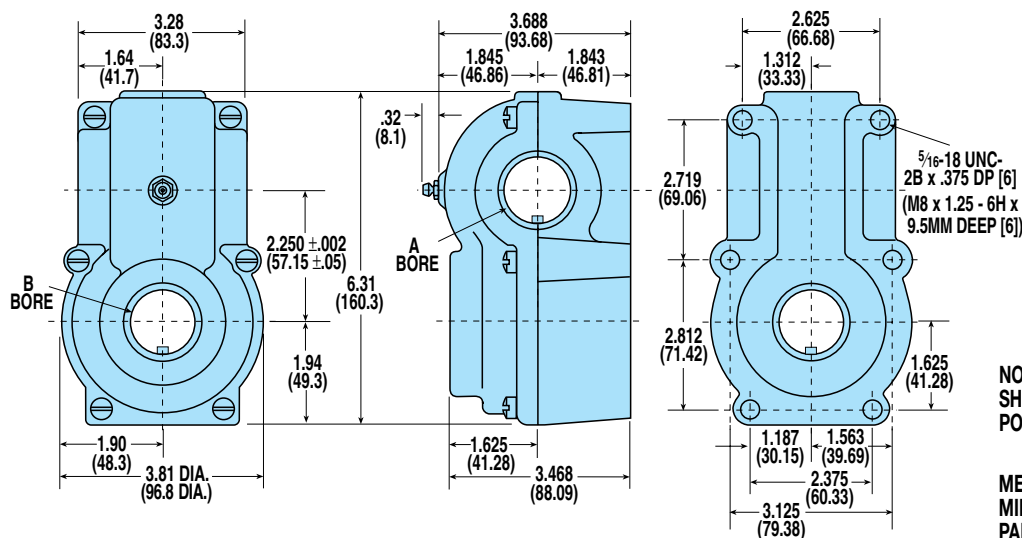

### Models and Bore Dimensions

#### U.S.- STANDARD FLAT BASE - 2:1 HIGH TORQUE ROLLER BEARING

HIGH TORQUE ROLLER MODEL NO.	RH OR LH	"A" BORE		"B" BORE	
		BORE SIZE (IN.)	WxD KEYWAY (IN.)	BORE SIZE (IN.)	WxD KEYWAY (IN.)
0279-0200	RH	1/2	1/8 x 1/16	3/4	3/16 x 3/32
0280-0200	LH	1/2	1/8 x 1/16	3/4	3/16 x 3/32
0281-0200	RH	1/2	1/8 x 1/16	1	1/4 x 1/8
0282-0200	LH	1/2	1/8 x 1/16	1	1/4 x 1/8
0283-0200	RH	1/2	1/8 x 1/16	1-1/4	1/4 x 1/8
0284-0200	LH	1/2	1/8 x 1/16	1-1/4	1/4 x 1/8
0285-0200	RH	5/8	1/8 x 1/16	3/4	3/16 x 3/32
0286-0200	LH	5/8	1/8 x 1/16	3/4	3/16 x 3/32
0287-0200	RH	5/8	1/8 x 1/16	1	1/4 x 1/8
0288-0200	LH	5/8	1/8 x 1/16	1	1/4 x 1/8
0289-0200	RH	5/8	1/8 x 1/16	1-1/4	1/4 x 1/8
0290-0200	LH	5/8	1/8 x 1/16	1-1/4	1/4 x 1/8
0291-0200	RH	3/4	3/16 x 3/32	3/4	3/16 x 3/32
0292-0200	LH	3/4	3/16 x 3/32	3/4	3/16 x 3/32
0293-0200	RH	3/4	3/16 x 3/32	1	1/4 x 1/8
0294-0200	LH	3/4	3/16 x 3/32	1	1/4 x 1/8
0295-0200	RH	3/4	3/16 x 3/32	1-1/4	1/4 x 1/8
0296-0200	LH	3/4	3/16 x 3/32	1-1/4	1/4 x 1/8

#### METRIC - STANDARD FLAT BASE - 2:1 HIGH TORQUE ROLLER BEARING

HIGH TORQUE ROLLER MODEL NO.	RH OR LH	"A" BORE		"B" BORE	
		BORE SIZE (MM)	WxD KEYWAY (MM)	BORE SIZE (MM)	WxD KEYWAY (MM)
0422-0200	RH	15	5 x 2.5	20	6 x 3
0423-0200	LH	15	5 x 2.5	20	6 x 3
0424-0200	RH	15	5 x 2.5	25	8 x 3.5
0425-0200	LH	15	5 x 2.5	25	8 x 3.5
0426-0200	RH	15	5 x 2.5	30	8 x 3.5
0427-0200	LH	15	5 x 2.5	30	8 x 3.5

**NOTE: METRIC SIZES AVAILABLE ONLY IN HIGH TORQUE ROLLER BEARING MODELS.**

**NOTE:** FOR HIGH TORQUE ROLLER BEARING MODELS THE "A" BORE CONTAINS THE 15 TOOTH GEAR. THE "B" BORE CONTAINS THE 30 TOOTH GEAR.

# Float-A-Shaft Gearbox

## STANDARD SERIES - 2 1/2:1 RATIO - US

### AVAILABLE STYLES

#### Low Torque Journal Bearings

##### Standard

3-1/2 lbs. (1.59 kgs.)



### PERFORMANCE DATA

#### Low Torque Journal Bearings

#### Torque and Efficiency vs RPM at Maximum Bearing Temperature

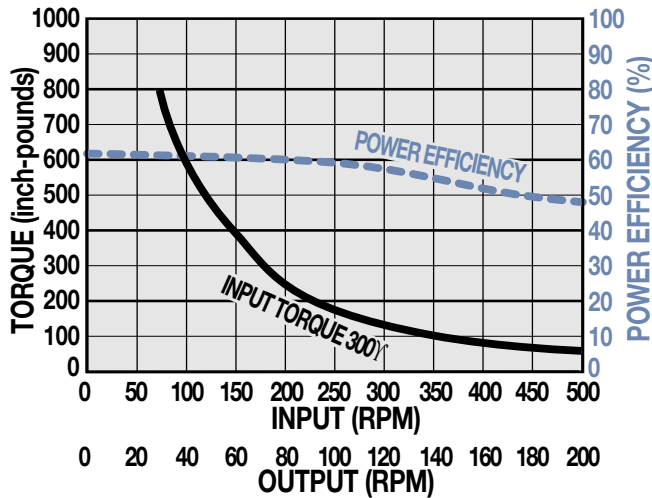

### DIMENSIONS: STANDARD LOW TORQUE BEARINGS

Model Builder 3D CAD Available at: [www.tolomatic.com](http://www.tolomatic.com)

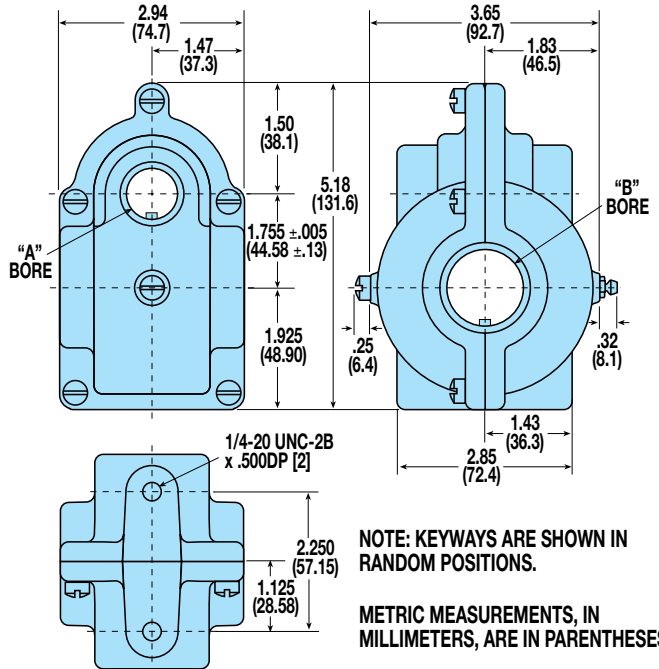

### Models and Bore Dimensions

#### U.S. - STANDARD - 2 1/2:1 LOW TORQUE JOURNAL BEARING

LOW TORQUE JOURNAL MODEL NO.	RH OR LH	"A" BORE		"B" BORE	
		BORE SIZE (IN.)	WXD KEYWAY (IN.)	BORE SIZE (IN.)	WXD KEYWAY (IN.)
0403-0000	LH	1/2	1/8 x 1/16	3/4	3/16 x 3/32
0404-0000	RH	1/2	1/8 x 1/16	3/4	3/16 x 3/32
0407-0000	LH	1/2	1/8 x 1/16	1	1/4 x 1/8
0408-0000	RH	1/2	1/8 x 1/16	1	1/4 x 1/8
0411-0000	LH	1/2	1/8 x 1/16	1-1/4	1/4 x 1/8
0412-0000	RH	1/2	1/8 x 1/16	1-1/4	1/4 x 1/8
0417-0000	LH	5/8	1/8 x 1/16	3/4	3/16 x 3/32
0418-0000	RH	5/8	1/8 x 1/16	3/4	3/16 x 3/32
0421-0000	LH	5/8	1/8 x 1/16	1	1/4 x 1/8
0422-0000	RH	5/8	1/8 x 1/16	1	1/4 x 1/8
0425-0000	LH	5/8	1/8 x 1/16	1-1/4	1/4 x 1/8
0426-0000	RH	5/8	1/8 x 1/16	1-1/4	1/4 x 1/8

NOTE: THE "A" BORE CONTAINS THE 10 TOOTH GEAR. THE "B" BORE CONTAINS THE 25 TOOTH GEAR.

# SELECTION

## 1.) DETERMINE INPUT TORQUE AND RPM REQUIRED

To select the Slide-Rite®, Slide-Rite®CR Gearbox, or Float-A-Shaft gearbox required for your application, you must determine the input torque and RPM required for your application. The maximum RPM rating for the Float-A-Shaft is 500 RPM, for the Slide-Rite® and the Slide-Rite®CR Gearbox it's 1200 RPM.

## 2.) NEED A GEAR RATIO OTHER THAN 1:1?

When utilizing the Float-A-Shaft ratioed units, the highest RPM shaft speed on either the input or the output shaft should not exceed 500 RPM. For the Slide-Rite ratioed units, the shaft speed (input or output) should not exceed 1200 RPM.

## 3.) REFER TO THE CATALOG PAGE FOR THE RATIO YOU HAVE SELECTED

Find your input torque in inch-pounds for the selected gearbox unit on the graph and intersect it with the RPM of the input shaft. In general, gearbox capacity increases as listed below:

- 1.) Float-A-Shaft: Compact: Low Torque Journal Bearings
- 2.) Float-A-Shaft: Compact: High Torque Roller Bearings
- 3.) Slide-Rite CR: Compact
- 4.) Float-A-Shaft: Standard: Low Torque Journal Bearings
- 5.) Slide-Rite: Compact
- 6.) Slide-Rite CR: Standard
- 7.) Float-A-Shaft: Standard: High Torque Roller Bearings
- 8.) Slide-Rite: Standard

For ratios other than 1:1 refer to the performance graph for that Float-A-Shaft gearbox. When torque vs RPM intersects below the 300°F curve, you have selected a gearbox suitable for your application.

If your torque vs RPM intersection point is above the 300°F curve, then you do not have a proper application for that gearbox. Your options are to reduce either your input torque or RPM to get under the 300°F curve or try a gearbox with greater capacity.

## 4.) SELECT PROPER BORE SIZE

After gearbox series selection, choose the bore size that suits your shaft requirements. (NOTE: Float-A-Shaft high torque roller bearing models and Slide-Rite 1:1 ratio models are available in metric sizes also.)

## 5.) DETERMINE YOUR OUTPUT TORQUE

## SLIDE-RITE™ & SLIDE-RITE™CR SELECTION EXAMPLE

Example: Slide-Rite® Gearbox Standard Series at 700 RPM and 90 inch-pounds of input torque (Refer to the graph shown below. From page 5)

Output torque = (Input torque) (efficiency) (ratio)  
 Output torque = (90 in.-lbs.) (.88) (1:1)  
 Output torque = 79 in.-lbs.

### PERFORMANCE DATA High Torque Ball Bearings Torque and Efficiency vs RPM at Maximum Bearing Temperature

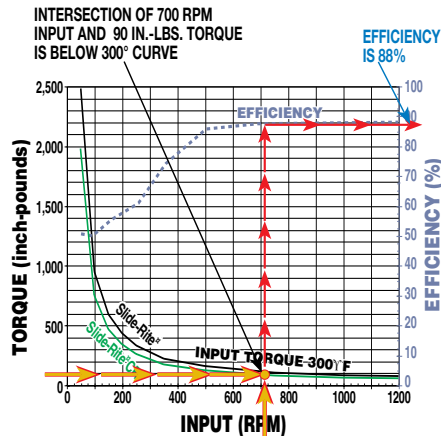

## FLOAT-A-SHAFT SELECTION EXAMPLE

Multiply the input torque by the gearbox's efficiency times the gear ratio. See examples:

Example: 3:2 Ratio Journal Bearing Float-A-Shaft at 50 RPM and 500 inch-pounds of input torque (See graph below. From page 16)

Output torque = (Input torque) (efficiency) (ratio)  
 Output torque = (500 in.-lbs.) (.62) (3:2)  
 Output torque = 465 in.-lbs.

### STANDARD SERIES 3:2 RATIO

### PERFORMANCE DATA Low Torque Journal Bearings Torque and Efficiency vs RPM at Maximum Bearing Temperature

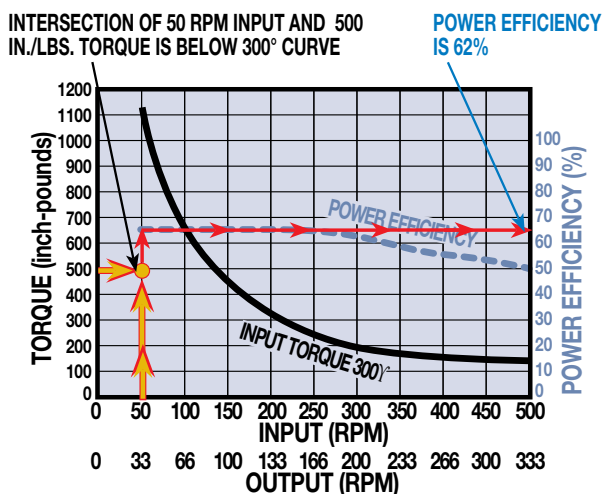

# Gearbox

SLIDE-RITE GEARBOX

ENDURANCE TECHNOLOGY

APPLICATION EXAMPLE

COMPACT SERIES 1:1 RATIO

STANDARD SERIES 1:1 RATIO

STANDARD SERIES 3:2 RATIO

STANDARD SERIES 2:1 RATIO

FLOAT-A-SHAFT

APPLICATIONS

INTRODUCTION

COMPACT SERIES 1:1 RATIO

STANDARD SERIES 1:1 RATIO

STANDARD SERIES 3:2 RATIO

STANDARD SERIES 2:1 RATIO

STANDARD SERIES 2.5:1 RATIO

SELECTION

INSTALLATION

SHAFT & KEYWAY REQUIREMENTS

## INSTALLATION



A plastic or cardboard dowel is inserted through the shaft bores during assembly and shipped in place. It allows you to install the Slide-Rite®, Slide-Rite®CR Gearbox, or Float-A-Shaft gearbox on your shafts in less than a minute.

To install your gearbox, simply line up the keyway on your shaft with the key and bore of the gearbox. Push the shaft through into place! The dowel falls out the other side and can be thrown away.

Gearboxes need not be disassembled and reassembled during installation. The dowel holds the gears in perfect alignment during installation and protects the precision internal parts from contamination and damage during shipping.

This fast and easy method of installation can be used whenever the keyways on your shafts extend out to the end of the shafts. For shafts with shorter keyways, the Float-A-Shaft can be built around the shaft. (Slide-Rite® and Slide-Rite®CR gearboxes cannot be disassembled.)

### Rotation of left hand and right hand drive compared, Slide-Rite® gearbox shown

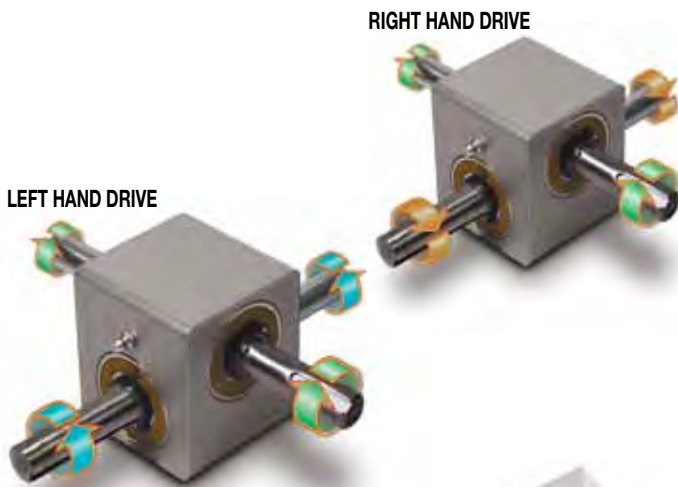

This bottle capping application utilizes both left hand and right hand gearboxes

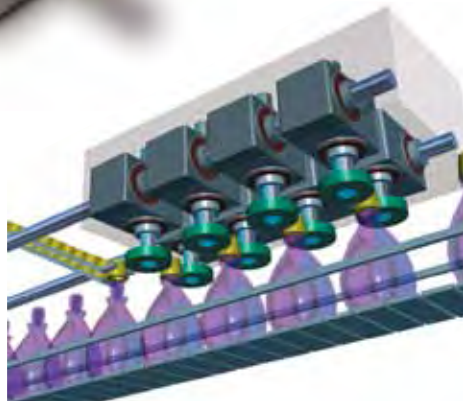

## SHAFT & KEYWAY REQUIREMENTS

### Shaft Diameter

Tolerance of plus 0.000 in. to minus 0.002 in. is recommended and should have runout within 0.002 in. TIR.

### Shaft Material

Use only alloy steel or stainless-steel for shafting, having a minimum hardness of RC40, or transmission shafting grade like 4140 or equivalent.

### Shaft Finish

In stationary applications the shaft finish should be 64 RMS or better. Shaft finish for traversing applications should be 32 RMS.

### Shaft Straightness

Shaft should be straight within 0.0015 in. TIR. per foot.

### Keyway

Keyway should be made up to 0.001 oversize than the nominal. See dimension table for nominal keyway sizes. Sharp edges of keyway should be avoided.

### Shaft Support

The shafts should be supported rigidly with either bearing blocks or pillow blocks to avoid excessive deflection. Gearbox bearings are designed to support the internal thrust and radial loads generated by the gear teeth. Shaft support should be located as close to the gearbox body as the application will allow. Supports greater than 25" from gearbox body (20" for compact models) can reduce gearbox efficiency and, ultimately, its life.

### Lubrication, all gearboxes

An extreme-pressure synthetic lubricant which exhibits excellent anti-wear and rust protection qualities such as Mobilith® SHC 460 [14 oz. cartridge #0100-1605] or equivalent is recommended.

Temperature range .....	0 - 300°F
NLGI Number .....	1.5 - 2
Dropping Point (ASTM D566) .....	490+
Penetration Worked (ASTM D217) .....	300

Slide-Rite® Gearbox is a registered trademark of Tolomatic, Inc.

Mobilith® SHC 460 is a registered trademark of Exxon Mobil Corporation, [www.mobil.com](http://www.mobil.com)

### Lubrication, Slide-Rite® gearboxes

The Slide-Rite® Gearbox is lubricated at the factory and is ready for installation. **For most applications the unit is greased for life.** (See the Slide-Rite Gearbox service sheet [#0100-4002 at [tolomatic.com](http://tolomatic.com)] for lubrication guidelines.)